

**Seminar on Economic and Market Analysis for Central and Eastern
European countries (CEEC) and Baltic States**

Czech Republic, Prague 9-11 September 2003

BDT & the Economics of Spectrum Management

□ 2001 SG3 referred to Report SM 2012 (ITU-R) urging the BDT to organize seminars to treat with economic aspects of spectrum management.

Prime concern:

□ To develop appropriate methods to ensure that developing countries obtain adequate financial resources to facilitate efficient spectrum management.

Importance of Adequate Financial Resources

- ❑ Facilitate new spectrum-using services
- ❑ Permit services to operate at acceptable interference-free levels;
- ❑ Ensure that the population is not taxed unnecessarily in order to permit commercial spectrum users to operate.

Overview of Spectrum Market

- ❑ Strong growth in demand for spectrum for commercial purposes.
- ❑ Internationally, derived demand for commercial spectrum has been driven largely by growth in demand for mobile services and attendant infrastructure, (e.g. fixed terrestrial links which require spectrum to facilitate mobile the services).
- ❑ With the advent of internet access over mobile handsets and developments in convergence technology, (SMS, MMS) demand for commercial spectrum is certain to accelerate, even in the near 4 future.

Market Value of Spectrum

❖ Spectrum is socio-economic resource of high commercial value that must be managed in a manner that ensures efficient utilization the resource.

□ Imperative to efficient spectrum management methodology is the formulation/adoption/adaptation of market oriented spectrum formulae that enable reasonably accurate estimation of economic values of frequencies, particularly in commercial bands.

Estimating Market Value

- ❖ Since the development of the use of radio Frequencies as a communication medium , licence fees for spectrum usage have been determined primarily by two methods:
 - a) Fee structure which invariably pegged annual charges at some percentage of gross/net profit.
 - b) Fee structure which simply ensured coverage of fixed administrative costs.
- ❖ Under these systems, spectrum hoarding has been easy and incentive to introduce more spectrum-efficient technologyalmost absent.

Marginal Value

- ❖ Studies indicate that spectrum reserved for commercial uses, and not assigned to its highest value user (market value) represents a misallocation of the resource, a sub-optimal investment decision that benefits the user at the expense of the wider economy of the country.
- ❑ Case in point: whenever high capacity fixed radio link is under-priced, it is usually more economical for an operator not to use cable on its trunk network.
- ❑ This may be good economics for the operator but poor for the country.

Opportunity Cost

- ❑ The extent of loss of spectrum revenue to a country is contingent on economic valuation of the spectrum.
- ❑ Where spectrum is currently or, will be in the near future, subject to competitive use, pricing should be based on its market value.
- ❑ As far as possible, spectrum usage fees should be consistent with the opportunity cost of the commodity.
- ❑ The difficulty is how should the opportunity cost of spectrum be estimated/determined.
- ❑ No precise answer; spectrum valuation is not a set science.

Basic Demand Principles

- Demand for spectrum is derived demand.
- Positive Correlation between demand for services facilitated by spectrum and demand for spectrum.
- Demand for spectrum for non commercial uses, e.g. national security should not be assessed in like manner as demand for spectrum for commercial uses.

Derived Demand for Spectrum

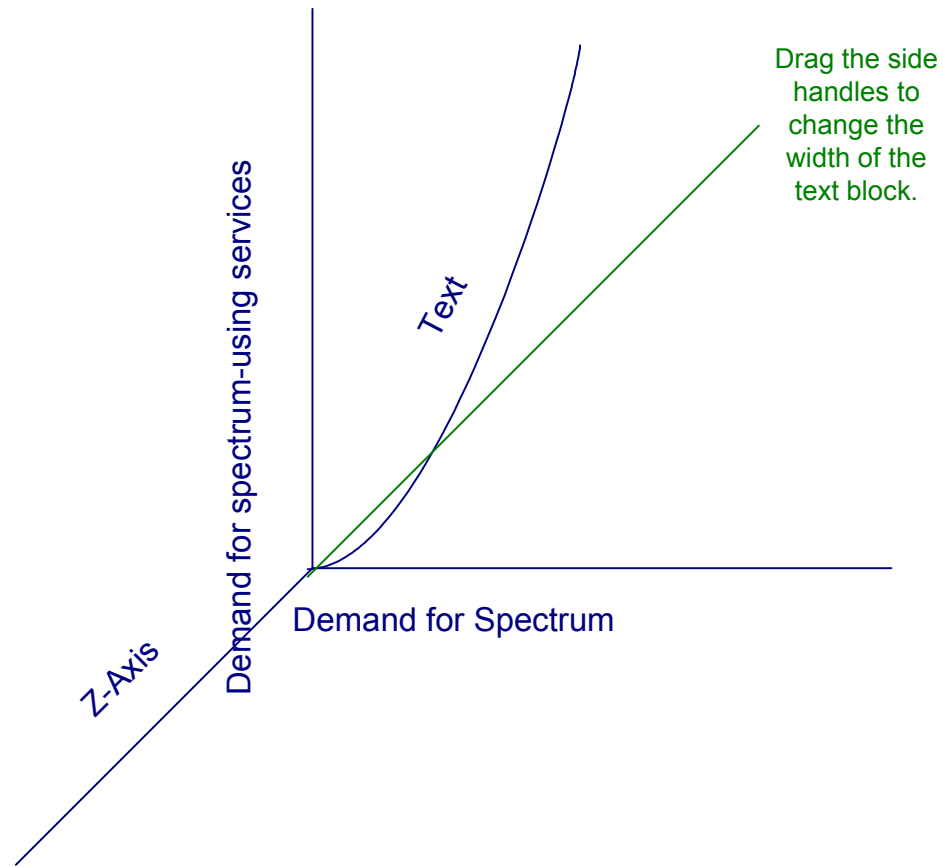

Market Simulation Methodologies

- a) Auction: fees set directly by the market.
- b) Indicative Pricing fees set by spectrum manager/regulator based on a basket of economic criteria which are usually surrogates for market mechanisms including:
 - i) Market Oriented; and
 - ii) Cost oriented Pricing.

AUCTION

- ❑ Efficient allocation of commercial spectrum, in that a well designed auction should identify the user with keenest sense of the optimal economic value and who is likely to generate highest economic benefits.
- ❑ The market sets the price of the spectrum.
- ❑ Transparent and fair system of allocation.
- ❑ Less unfavourable to new market entrants.
- ❑ Not suitable for low value high volume spectrum e.g. private radio used by taxi.
- ❑ Ideal in situations where demand for spectrum outstrips supply.

Auction Design

- ✓ Scientific design, in particular the minimum bid, is crucial if an auction is to perform the functions of the market.
- ✓ The minimum should be based on quantitative methods, See Appendix.
- ✓ The difficulty Developing countries is to generate auction prices that are market reflective and, at the same time, not disproportionately disadvantageous to new entrants.

Base Price/Auction Surplus

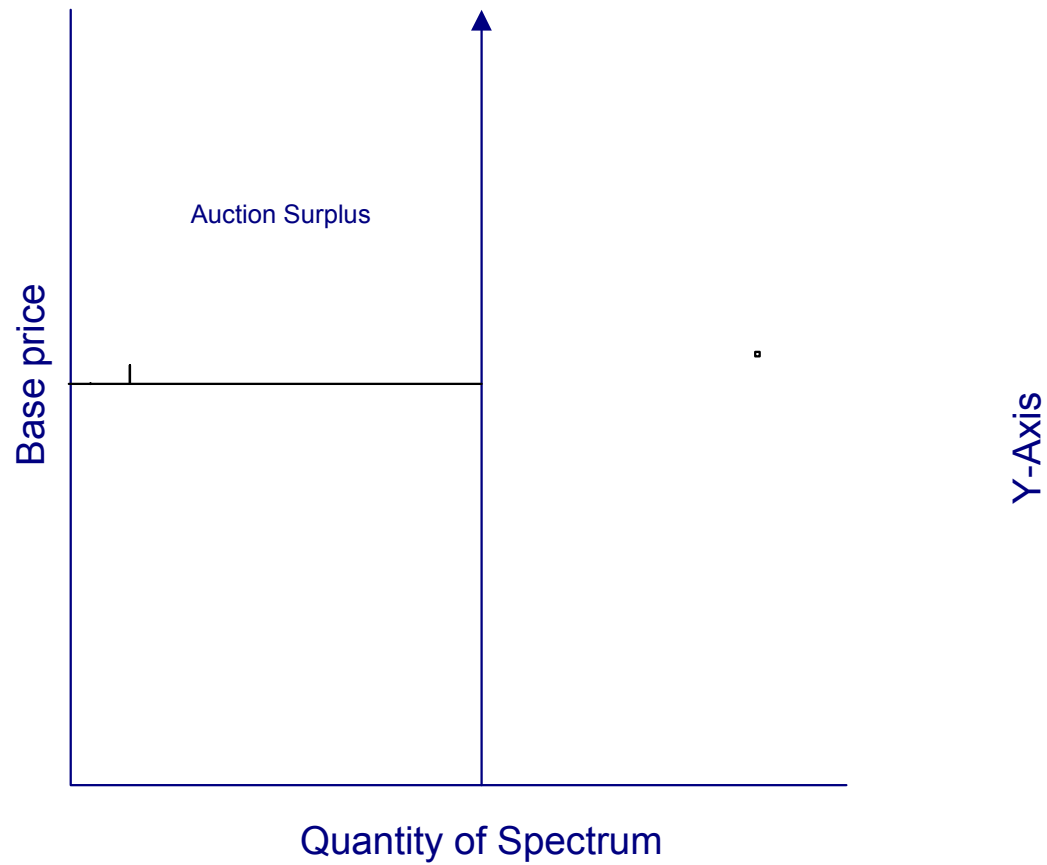

Auction: Myths

❖ **Auction increases operators cost and in turn price of end product paid by consumers;**

❑ In general, economic theory of market behaviour and empirical evidence lend little support.

❖ **Auction is a money printing mechanism.**

❑ In a competitive market, the price of the end product will be determined by market forces.

Market Oriented Pricing

Simulation of market using relevant indicators that impact the price of spectrum should realize on the open market.

These indicators include, inter alia:

- a. Efficient spectrum usage;
- b. Socio-Economic benefits to be derived from spectrum usage;
- c. Impact of technology innovation on spectrum usage;
- d. Demand & supply of frequency; and
- e. The degree of competition in the market .

Important Considerations Re: Spectrum Benefit

- ❑ Expansion of Manufacturing capability.
- ❑ Creation of new radio services/industries.
- ❑ Increased employment.
- ❑ Cost effective availability of social services.
- ❑ Backward & Forward Linkages:
 - i. Equipment supply.
 - ii. Market research.
 - iii. IT support.

Basic Concept

□ Like all natural resources, e.g. oil, the Market Oriented Pricing concept is that economic rent is applicable to commercial exploitation of spectrum to produce goods/services.

□ Economic rent (license fee) could be captured on the basis of scarcity and differential use.

(i) Scarcity Rent:

Demand for frequency in commercial bands, in certain areas, exceeds supply at zero price.

(ii) Differential Rent:

- ❑ Each frequency band has unique propagation characteristics that may be suitable for specific services.
- ❑ Access to ideal frequency bands could minimize cost and optimize performance of radio systems.
- ❑ Bands suitable for multiple services using low cost equipment would be more valuable to those less flexible and require use of costly equipment.

Opportunity Cost and Economic Rent

- ❑ Opportunity cost is likely to play a major role in establishing economic rent.
- ❑ Opportunity cost impacts scarcity.
- ❑ Opportunity cost impacts differential usage.

Simulating Opportunity Cost

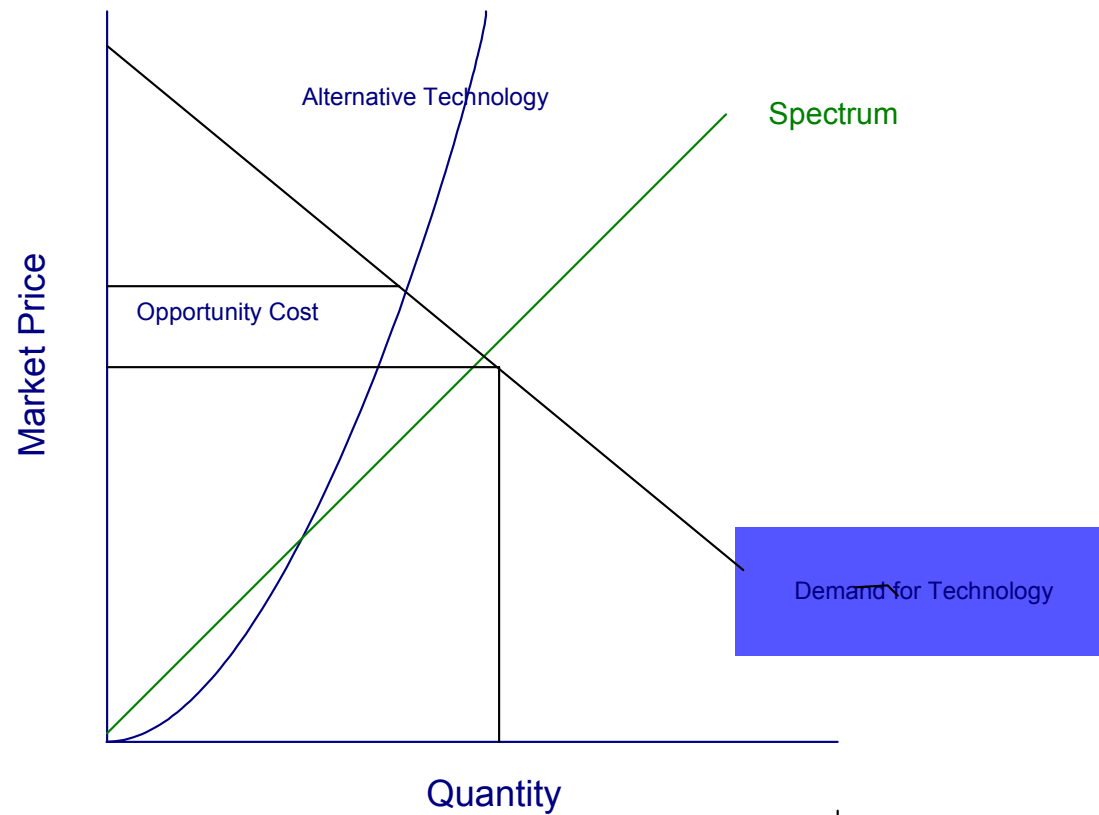

Simulation Methodology

- I. Develop matrix of alternatives to current network (trunked systems, more efficient sharing, reuse, moving to different frequency bands etc.)
- II. Estimate equipment life span and derive depreciation values.
- III. Derive initial annual licence fee on the basic of least cost alternative.
- IV. Apply adjustment factors ie quantitative proxies to account for factors such as: competition, quality of service and spectrum usage constraints that are influenced by propagation characteristics

Opportunity Cost, Cellular Spectrum

Important Elements:

Assuming optimal utilization of spectrum by

Any operator:

- The opportunity cost of cellular spectrum can be estimated by calculating the least cost options available to the network operator in the event that spectrum is not available for network expansion.

•

Basic GSM Network

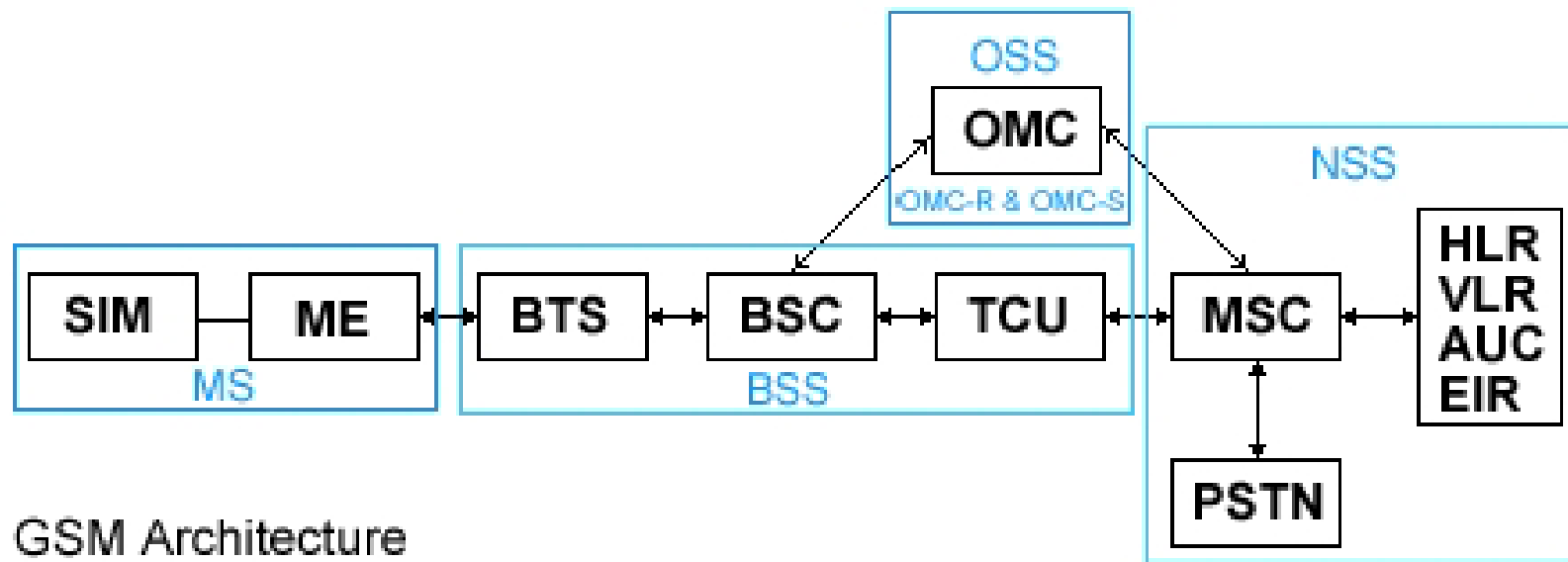

Basic GSM Network

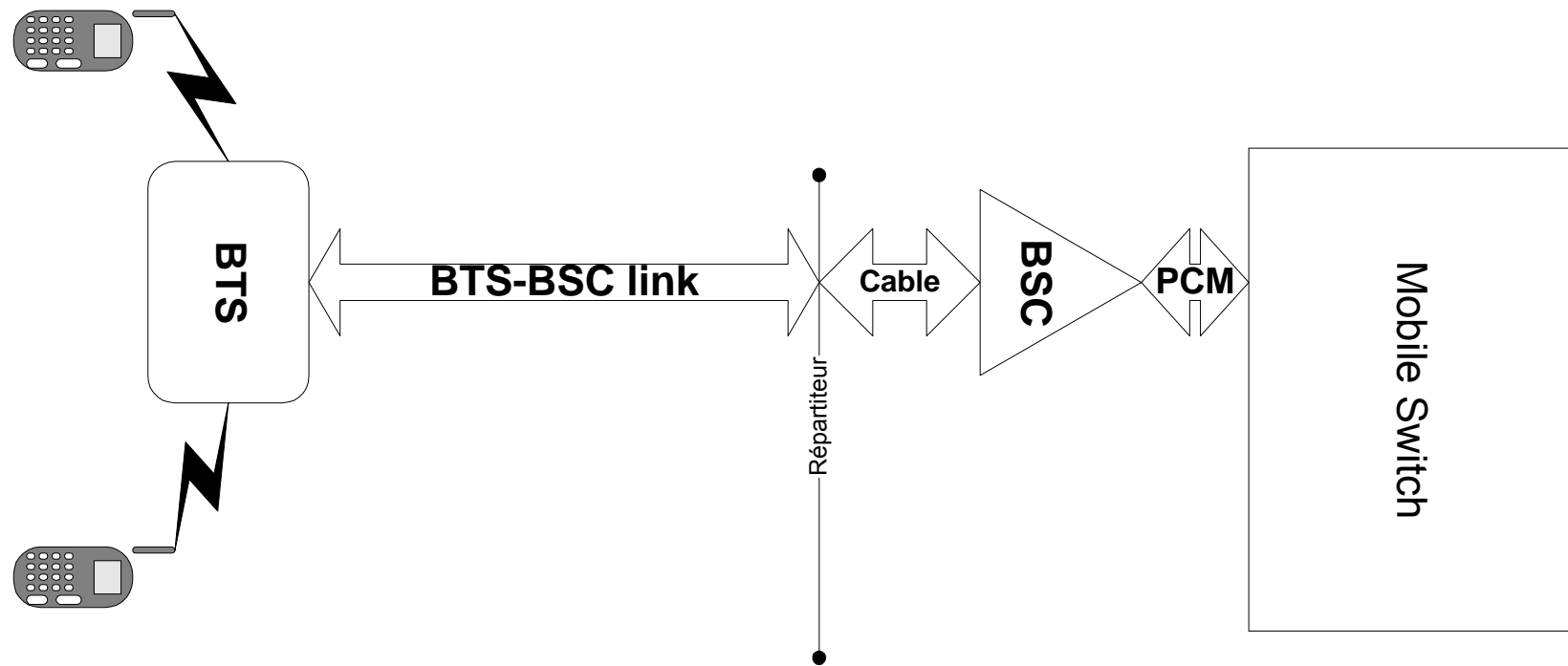

Model Structure

1. Structure current network.
2. Structure expansion of current network capacity as a function of change in demand for service.
3. Structure network expansion using smaller cells within the same spectrum used by the current network.
4. Structure network expansion assuming availability of additional spectrum.
5. Estimate cost differential between both networks.

Cost Methodology

- Estimate (Z) cost of current network.
- Estimate ($C1$), cost of network expansion using smaller cells.
- Estimate ($C2$), cost of network expansion using additional spectrum.
- Let (βf) indicate additional spectrum required, the opportunity cost of spectrum ($C!$) is estimated by:
 - $C! = (C1 - C2) / \beta f$

Importance of Assumptions

- Assumptions about cell planning.
- Assumptions about spectrum availability.
- Assumptions about depreciation.
- Assumptions about competition.
- Technology and socio-economic Assumptions.

Technology Parameters

- ❑ Number of cells
- ❑ Number of transceivers per cell
- ❑ Cell size

For:

- ❖ Current network
- ❖ Network expansion using smaller cells
- ❖ Network expansion using additional spectrum

Cost Elements

- ❖ Equipment costs for additional cells;
- ❖ Costs of additional transceivers;
- ❖ Site rental for additional cells;
- ❖ Cost of link to base station.

Financing Parameters

- Life time of equipment
- Discount rate to compute NPV.
- Spread profile for capital expenditure over X_i period.
- Cost adjustment factor/s.

Cell Planning Options

Network Expansion through:

1. Cell reduction by changing transmitter power.
2. Sectoring cells.
3. Addition of microcell layer over existing cell structure.

NB:Expansion should not apply in zones where there is little or no congestion.

Traffic Projection

Zone	Min Future Traffic (E/km ²)	Max Future Traffic (E/km ²)
Urban	60	90
Sub Urban	40	70
Rural	2	5
Remote Rural	1	3

Baseline Network

Zone	Current Traffic (E/km ²)	No Of cells	Carrier/Cell
Urban	77	80	8
Sub Urban	50	26	8
Rural	2.5	700	8
Remote Rural	1.5	1000	8
Total		1806	

Technical Assumptions

- i. Spectrum available is 2 x 24MHz.
- ii. 8 Carrier pairs per cell.
- iii. Network expansion via additional spectrum can be achieved with 1 more transceiver per cell.
- iv. Same increase in network capacity can be achieved through reduction of cell size or adding cells as necessary.
- v. No network congestion in rural and remote rural areas.

Cost Assumptions

- Capital Cost of adding new cells = £50,000, including cost of two transceivers.
- Site rental cost per annum = £ 2, 250 per cell.
- Link Cost = £ 1, 000 per transceiver per annum.
- Capital cost of adding transceivers to existing cell = £ 8,000

Zone	Increased Capacity E/km ²	Δ Network (smaller cells)	Carrier Cells	Δ Network (Additional Spectrum)	Carrier Cells
Urban	88	92	8	80	9
Sub- urban	57	30	8	26	9
Rural	3	897	8	700	9
Remote Rural	1.5	1000	8	1000	9
Total		1989		1806	

Financial Assumptions

- ❑ Discount rate (including adjustment factor) = 10%.
- ❑ Depreciation period on equipment 10 years.

- Expansion Using Smaller Cells

Total Cost	£ 105 663 000
NPV	£ 86 828 762
Spectrum Required	2 x 24 Mhz

Expansion Using Additional Spectrum

-

Total Cost	£ 65 700 000
NPV	£ 53 190 935
Spectrum Required	2 x 27 MHz
Estimated value of Spectrum	£ 1 245 584 per 2*1MHz per annum



Sensitivity Analysis

- Estimated licence fees are often very sensitive to:
- Discount rate
- Multiplier = $\sum_{\kappa} 1/(1+r)^{\kappa}$
- Where $\kappa = 1 \dots n$

Indicative Cost (User Fee) Concept

- Spectrum should be managed within the ITU Radio Regulations and in the National Interest to ensure adequate short and long term provision for public and private correspondence.
- Management activities include, inter alia:
- Orderly allocation of frequency bands;
- Minimizing RF interference among national and international services;

- Assign frequencies to specific licensees;
- Monitor compliance;
- Spectrum management policy planning;
- Authorization of equipment and specification of equipment standards;
- International cooperation, liaison and consultation;
- Spectrum engineering support;
- IT support; and
- Economic, administrative and legal support.

Concept

- Spectrum management activities incur direct and indirect costs as well as secondary cost.
- Such costs should be covered by licensees who use spectrum, in particular usage for commercial purposes.

Estimating Indicative Costs (Spectrum User fee)

$$\text{Spectrum User Fee } (T_{su}) = f(K_{sm}, A_{sm})$$

Where:

- K_{sm} = Annual basic costs of spectrum Management (Direct + indirect)
- A_{sm} = Secondary costs of spectrum use, as determined by:
 - i. Bandwidth used.
 - ii. Coverage area and population density of area.
 - iii. Spectrum Employment.
 - iv. Spectrum monitoring complexity.
 - v. Type of service.

Assumptions

- ❖ Positive correlation between bandwidth and Value of spectrum.
- ❖ Positive correlation between population density in coverage area and value of spectrum.
- ❖ Positive correlation in spectrum monitoring complexity & marginal cost of spectrum administration.
- ❖ Positive correlation between exclusivity of use & payment.

Specification of Parameters

$$K_{sm} = (K_1, K_2),$$

Where:

- K_1 = State expenditure on spectrum management.
- K_2 = Collateral charges re spectrum management.

Defining K_1

$$K_1 = f(k_{i1}, k_{i2}, k_{i3})$$

Where:

□ k_{i1} is State expenditure on purchase, installation and maintenance of spectrum management system and infrastructure including: radio monitoring station equipment, direct finders, computer hardware & software, amortization of building, etc.

Defining K_1

- k_{i2} = State costs associated with scientific research, purchase of scientific literature, electromagnetic compatibility analysis, frequency assignment, coordination, etc.
- k_{i3} = Spectrum Management staff salaries.

Defining K_2

$$K_2 = f(k_{z1}, k_{z2},)$$

- Where:
 - k_{z1} , is taxes imposed by the State on spectrum management equipment, buildings, etc.
 - k_{z2} is applicable if there is any payment required by the State for initial use of spectrum.

Defining A_{sm}

$$A_{sm} = f(\pi_i, F_3, T)$$

Where:

- ❖ π_i is the socio-economic value of the frequency resource used for the i th frequency assignment;
- ❖ F_{n3} is the area used for the i th frequency assignment; and
- ❖ T , time = one year.

Defining π_i

$$\pi_i = \Delta f_i (\alpha \lambda_i)$$

- Where:

Δf_i denotes the i th frequency used in a frequency band.

- 1) α_i is the exclusivity factor of use of the i th frequency which assumes a value ($0 < \alpha_i < 1$)
- 2) λ_i is the factor which takes into account:
 - a) λ_1 the commercial value of the spectrum range;
 - b) λ_2 the complexity of spectrum management in the band.

Defining F_3

$$F_3 = f(D_i * P)$$

Where:

- D_i is the population density coefficient which assumes a value between low density (L_d) and high (H_d).
- P is the coordination site located in the high density area.

Population density in a country is invariably inconsistent and operators, in particular new ones, tend to prefer high density areas. For simplicity the model divides the country into low density (L_d) and high density (H_d) areas.

- Accordingly, the value of D_i may vary between 0.1-1.

Estimating Cost Per Licence

Cost licence (T_{sui}) is therefore:

$$\square T_{sui} = [(K_{sm,})/n + (A_{smi})]$$

- Where:

n is the total number of licences awarded.

ANNEX

Determination Of Minimum Bid

- **i) Number of base stations (BS) in the mobile network as a function of the bandwidth**
 - The first group of basic data includes the parameters shown in Table 1, which are used to determine the following key parameters of the mobile communication network:
 - N - cluster size;
 - C - number of BS that have to be installed in a town;
 - n_c - number of telephone channels.

Symbol	Parameter	Value Estimated
F	Bandwidth for network in s/area	2-25MHz
$F_k = 25,00 \text{ \& } 200 \text{ kHz}$	Channel B/Width	0.2MHz
$M = 6 \text{ for } \theta = 60^\circ$	No of Sectors served per cell	1-6

Symbol	Parameter	Estimated Value
$n_{\alpha} = 1, 3 \text{ \& } 8$ respectively	Number of subscribers using Channel simultaneously	8
N_{α}	Number of urban subscribers	10,000-150,000
β	Peak hour use per subscriber	0.025 Erlangs

$\bar{O} = 4-10 \text{ dB}$	Random variation in signal received	6 dB
$P_{\acute{\alpha}}$	Probability of call blocking in N/work	0.1
$\rho_o = 18, 9 \text{ and } 9\text{dB}$	Required protection for Receivers	9dB
P_t	% of received signal/interference ratio falling below Protection ratio	10%

- 1) Total number of frequency channels in a cellular mobile network in a town:
- $$n_k = \text{int}(F/F_k)$$
- where $\text{int}(x)$ is the integer part of the number x .
-

2) Required cluster size for given values of ρ_o and P_T :

$$p(N)=100 \frac{\int_{\frac{(10 \lg(1/\beta_e) - \rho_o)}{\sigma_p}}^{\infty} e^{-\frac{t^2}{2}} \frac{dt}{\sqrt{2\pi}}$$

where $p(N)$ is the percentage of time during which the signal/interference ratio at the mobile station receiver input falls below the protection ratio ρ_o . The values β_e and σ_ρ depend on the parameters $q = , \sigma$ and M . The value of $p(N)$ decreases as N increases. For given values of ρ_o, σ and $M = 1, 3$ and 6 , values of $p(N)$ are calculated for a number of values of N (i.e.: q). The value of N for which the condition $p(N) \leq P_t$ is fulfilled is taken as the cluster size for the mobile network.

The parameters β_e and σ_ρ used in the equation for $p(N)$ are determined using the following expressions:

$$\sigma_\rho^2 = \sigma^2 + \sigma_e^2$$

$$\sigma_e^2 = \frac{1}{\lambda^2} \text{Ln} \left[1 + (e^{\lambda^2 \sigma^2} - 1) \frac{\sum_{i=1}^{\lambda} \beta_i^2}{\left(\sum_{i=1}^{\lambda} \beta_i \right)^2} \right]$$

$$\beta_e = \left(\sum_{i=1}^{\lambda} \beta_i \right) \exp \left[\frac{\lambda^2}{2} (\sigma^2 - \sigma_e^2) \right].$$

Here, $\lambda = (0.1 \ln(10))$ and the values λ and β_i depend on M and may be found using the following formulae:

if $M=1$, then $\lambda=6$

$$\left. \begin{aligned} &\beta_1 = \beta_2 = (q-1)^{-4}; \beta_3 = \beta_4 = q^{-4}; \beta_5 = \beta_6 = (q+1)^{-4} \\ &\text{if } M=3, \text{ then } \lambda=2 \\ &\beta_1 = (q+0.7)^{-4}; \beta_2 = q^{-4}; \\ &\text{if } M=6, \text{ then } \lambda=1 \\ &\beta_1 = (q+1)^{-4}, \end{aligned} \right\}$$

where $q = \sqrt{3N}$

3) Number of frequency (n_s) and telephone (n_c) channels used to serve subscribers in one sector of one cell:

$$n_s = \text{int}(n_k/MN)$$

$$n_c = n_s \cdot n_\alpha.$$

4) Admissible telephone traffic in one sector of one cell (Erlang):

$$A = \begin{cases} n_c \left[1 - \sqrt{1 - \left(p_a \sqrt{\pi n_c / 2} \right)^{1/n_c}} \right] \bullet \text{ for } p_a \leq \sqrt{2 / \pi n_c} \\ n_c + \sqrt{p / 2 + 2 n_c \text{Ln} \left(p_a \sqrt{\pi n_c / 2} \right)} - \sqrt{p / 2} \bullet \text{ for } p_a > \sqrt{2 / \pi n_c} \end{cases}$$

5) Number of subscribers served by one BS for a given value of blocking probability:

$$N_{BS} = M \cdot \text{int} (A/\beta)$$

6) The number of BS in the cellular network is determined as follows:

$$C = \text{int} (N_\alpha/N_{BS}) + 1$$

Estimation Cost to Establish Mobile Network

Symbol	Parameter	Value
K_h	Avg Hourly rate per installation	3 (USD/hr)
K_{Bs}	Price SC/BS installation	USD 230,000
K_E	Unit cost R/trans	USD 11,000
A_1	Fixed cost	USD 351/ch
A_2		176/ch
B_1 & B_2	Variable Cost	USD23-12ch/km

- Expenditures =
- $$K_{\Sigma} = K_1 + K_2 + K_3 + K_4 + K_5$$
- Where:
- K_1 - cost of construction and assembly work
- K_2 - cost of BS equipment
- K_3 - cost of establishing a switching centre (SC)
- K_4 - expenditure for purchasing software and technical facilities for billing systems
- K_5 - cost of establishing communication links between BS and SC.

- Construction and assembly costs (K_1) are determined on the basis of statistical data [1], [2] on the labour consumption of the various stages of work. These costs are proportional to C , which is the number of BS in the mobile network, and may be determined by the equation:
- Capital costs for BS equipment are determined by the equation:
 - $$K_2 = C \times [K_{BS} + (M \times n_s) \times K_E]$$
 - where $(M \times n_s)$ is the number of frequency channels in one cell.
- The cost (K_3) of establishing the switching centre (SC) of a mobile network is determined from the data in Table 3 on the basis of the number of subscribers in the network.

Required no of channels on network	Switching centre	Cost K_3 (USD)
	Analogue	Digital
$N_a \leq 500$	300 000	3 500 000
$N_a \leq 2,000$	500 000	3 600 000
$N_a \leq 10,000$	1 300 000	4 000 000
$N_a \leq 50,000$	3 000 000	5 000 000
		69

Type of System	Cost K ₄ USD	
Simple System for 5000 subs	130 000	
Simple billing system for 10,000 Subscribers	240 000	
System with additional features For 10 000 subscribers	750 000	
System with additional features For 100 000 subscribers	1 400 000	

- The costs of communication links (N_{ck}) needed to connect one BS to the SC with a capacity of 60 or 30 telephone channels (with a transmission speed of 2 or 4 Mbit/s). The required number of communication links with a capacity of 30 telephone channels is as follows:

- $$N_2 = \text{int}((M \times n_c)/30)+1.$$

- Efficient capital outlay for BS-SC connections, Requires communication links of type 1 The number of such links will be:

- $$N_1 = \text{int}(N_{30}/2).$$

- Unit costs for one telephone channel with type 1 or type 2 links of length L_i are: $T_{1i} = A_1 + B_1 \times L_i$; $T_{2i} = A_2 + B_2 \times L_i$
- The coefficients A_1 , B_1 , A_2 and B_2 for cable, optical and radio-relay links:
- The cost of communication links between the i -th BS -SC is:
- $$K_{5i} = 60 \times N_1 \times T_{1i} + 30 \times N_2 \times T_{2i} = A + B \times L_i,$$
- where
- $$A = 60 \times N_1 \times A_1 + 30 \times N_2 \times A_2, \quad B = 60 \times N_1 \times B_1 + 30 \times N_2 \times B_2.$$

- The total cost of establishing communication links to connect all BS-STs
- where L_m is the average length of all BS-SC connection links. The length of these links may vary from 5 to 25 km. If the mobile network's coverage area is assumed to be a circle and base stations are uniformly distributed throughout this area, then:
- $$L_m = 2 \times [25^3 - 5^3] / 3 \times 25^2 \cong 16.6 \text{ km.}$$

Discounted Income of Network

Symbol	Parameter	Value
N_0	Initial N_0 of subscribers	300
T_1	Tariff per Min in Public Network	USD 0.05
X	Call ratio of network	0.7
K_{pH}	Busy hour call ratio	0.18
β	Subscriber busy hour activity	0.025
P_1	Mean Initial connect charge	USD 200
P_2	Mean Monthly Subscription	USD 50
P_3	Mean call tariff	USD 0.35
n	Licence period	10 yrs 74

- number of network subscribers, $N_a(t)$ may be calculated based on statistical data on the development of mobile networks using the formula:
- $$N_a(t) = \max \{N_0 \times \exp(v_k \times t),$$

where $(k-1) < t < k; N_\alpha\}$.

Year	2003	2004	2005	2006	2007- 2012
k	0	1	2	3	4-11
$N_{ak} =$ $N_a(k)$	2×10^3	13×10^3	53×10^3	132×10^3	$N_{a11} =$ 2×10^6
V_k	0	1.87	1.48	0.92	0.34

- Current annual expenditure ($Z_{\Sigma k}$) is $Z_{\Sigma k} = Z_{1k} + Z_{2k} + Z_{3k}$
- where
- Z_{1k} is the annual expenditure for operation, amortization, maintenance, administrative costs, salaries, captial cost, land rental. On the basis of the data, $Z_{1k} = 805 \times N_{aki}$
- Z_{2k} , annual expenditure for maintenance of billing system is:
 $Z_{2k} = \text{USD } 30\,000.$

- Z_{3k} is the annual expenditure for the lease of public network channels for one year.
- $$Z_{3k} = 12 \times N_{ak} \times Y_M \times X \times T_1.$$
- The value of Y_M , the monthly traffic for one subscriber, is the number of minutes per month during which a subscriber occupies a communication channel, and is determined by the equation:
- $$Y_M = 30.4 \times \beta / K_{PH}$$

- Income from operation of a mobile network for k years:

- $$D_{\Sigma k} = D_{1k} + D_{2k} + D_{3k}$$

- where

- D_{1k} includes: connection fee, guarantee deposit, access number, use of local public network operator's line, sales mark-up for subscriber equipment, as follows:

- $$D_{1k} = N_{ak} \times P_1.$$

- D_{2k} is income from monthly subscription fees.

- D_{3k} is income from monthly call fees.

-

-

Using the above relationship $N_a(t)$, we determine D_{2k} and D_{3k} as follows:

- $$D_{2k} = 12 \times P_2 \times \int_0^k N_{ak}(t) dt = 12 \times P_2 \times \{N_0 + \sum_1^k N_{ak} \times [1 - \exp(-v_k)] / v_k\}$$
- $$D_{3k} = 12 \times P_3 \times Y_m \times \{N_0 + \sum_1^k N_{ak} \times [1 - \exp(-v_k)] / v_k\}$$

In order to evaluate the economic efficiency of the operation of a mobile network, the discounted income index I_D , is calculated as the ratio of the sum of discounted net profit of the project to overall capital expenditure.

The current worth of future income is determined using the discounting index $(1 + E_n)$, where the value of E_n is taken as the mean annual bank rate. Thus:

$$I_D = \frac{1}{K_\Sigma} \sum_{k=0}^n [(1 - \delta)(D_{\Sigma K} - Z_{\Sigma K})] \frac{1}{(1 + E_n)^k} \quad 80$$

On the basis of the results obtained, the discount rate for the project may be calculated:

$$E_p = p\sqrt{I_D}$$

Discounted income is calculated as an annual amount relative to one dollar of investment in the project.

- The relationship between a cellular mobile network operator's discounted standard profit and bandwidth F , the number of subscribers served N_a and the number of sectors served M is shown in Figure 1. The graph reveals that an operator can make additional profit by using additional bandwidth. When determining the minimum bid, one fundamental principle must be to give operators an incentive to make more efficient use of the radio-frequency spectrum.

Figure 1

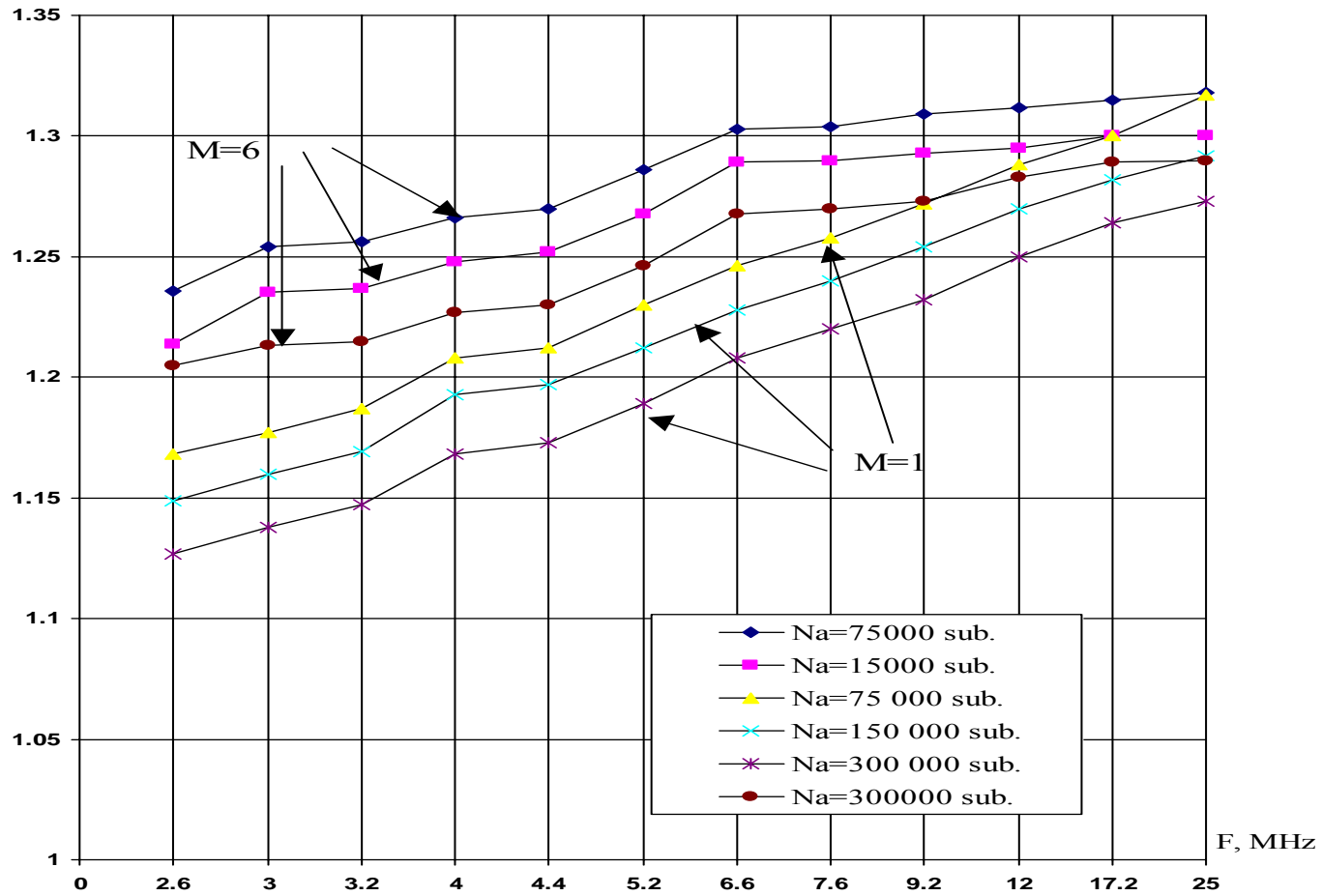

Minimum Bid

- The minimum bid is calculated by the equation:
- $$T = (E_n - E_r) \times D_{pr}/n.$$
- where D_{pr} is the net profit of the operator during the licence term.
- The profit standard for an operator set by the State for mobile communication enterprises is E_r

- Note that: 1) The Total number of frequency channels in a cellular mobile network in a town is :
 - $$n_k = \text{int}(F/F_k)$$
 - where $\text{int}(x)$ is the integer part of the number x .
- 2) Required cluster size for given values of ρ_o and P_T :
 -
 - where $p(N)$ is the percentage of time during which the signal/interference ratio at the mobile station receiver input falls below the protection ratio ρ_o . The values β_e and σ_p depend on the parameters $q = , \sigma$ and M . The value of $p(N)$ decreases as N increases. For given values of ρ_o, σ and $M = 1, 3$ and 6 , values of $p(N)$ are calculated for a number of values of N (i.e.: q).

- The value of N for which the condition $p(N) \leq P_t$ is fulfilled is taken as the cluster size for the mobile network.

Thank you