



ITU-APT Workshop on NGN Planning

16 – 17 March 2007, Bangkok, Thailand

Planning and design requirements for NGN

Oscar González Soto
ITU Consultant Expert
Strategic Planning and Assessment



Network Planning NGN and IMS Content

- **Role of Network Planning**
 - Requirements
 - Domains and methodology
- Network design issues in NGN
- Strategic Planning and Technology mapping



Network Planning Requirements Mission of network Planning



“Decision making on the network deployment
to Optimize Business and Quality
based on quantitative evaluation”

- Considering geo-marketing scenarios and traffic demand
- Overall vision on the network layers
- Deciding network topology, interconnection and routing
- Optimizing balance between performance/SLA and cost (CAPEX + OPEX)
- Considering regulatory constraints
- Anticipating business evaluation and feasibility



Network Planning Requirements Key requirements in competition (I)



- **Strategy Oriented Needs**
 - What selection of **customer classes** and associated services?
 - When to decide **migration** to new technologies and what speed?
 - Which level of **convergence** versus specialization?
 - What resources to **built and what to lease** ?
 - Which are the most convenient **partnerships** with other operators and suppliers?



Network Planning Requirements Key requirements in competition (II)



- **Business Oriented Needs**

- Which **services** have to be introduced through time ?
- What is the best **service bundling** per customer type ?
- How to maximize **revenues** ?
- How to reduce **capital expenditure** ?
- How to reduce **operational expenditure** ?
- How to **price services** and bundles?
- How to optimize network **profitability**?



Network Planning Requirements Key requirements in competition (III)



- **Network Oriented Needs**

- How to **forecast new services** and traffic demands?
- How many **nodes to install** ?
- What is best **location** for systems and related communication media ?
- What is the best network **architecture and routing** ?
- How to plan capacity evolution and solutions **migration** at access, local and transit segments?
- How to ensure **QoS** across multiple domains?
- How to ensure **protection level** and survivability?
- How to ensure and manage **SLA** ?



Network Planning Requirements Key requirements in competition (IV)



- **Operation Support Needs**
 - How to evaluate alternatives for **direct vs outsourced** operation ?
 - How to organize the **operation processes** ?
 - Which **level of integration** is needed to operate **multimedia services**?
 - Which **IT applications** ensure an efficient support to operation ?
 - How to plan **labor force training** on the new operational activities ?



Network Planning Requirements : Network Modeling for planning



- **High complexity of the whole Network requires a modeling and splitting in subnetworks to facilitate analysis , design and planning.**
 - **By Layers** in a vertical dimension following the client-server relation (one layer is supported in the layer below and provides resources for the layer up). **Physical, Transmission, Switching, etc.**
 - **By Segments** or splitting of the end to end communication into sub-areas as customer premises, access, core national, core international
 - **By Technologies** or underlying technique as SDH, WDM, ATM, IP, IMS, GSM, 3G, WiMax, etc.....

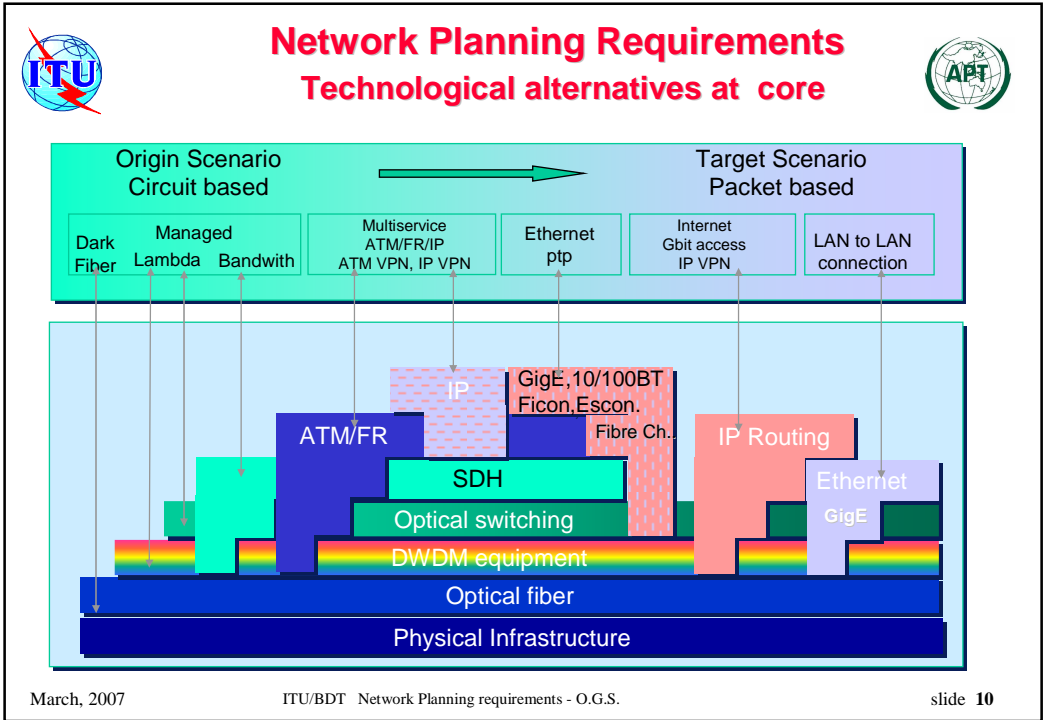
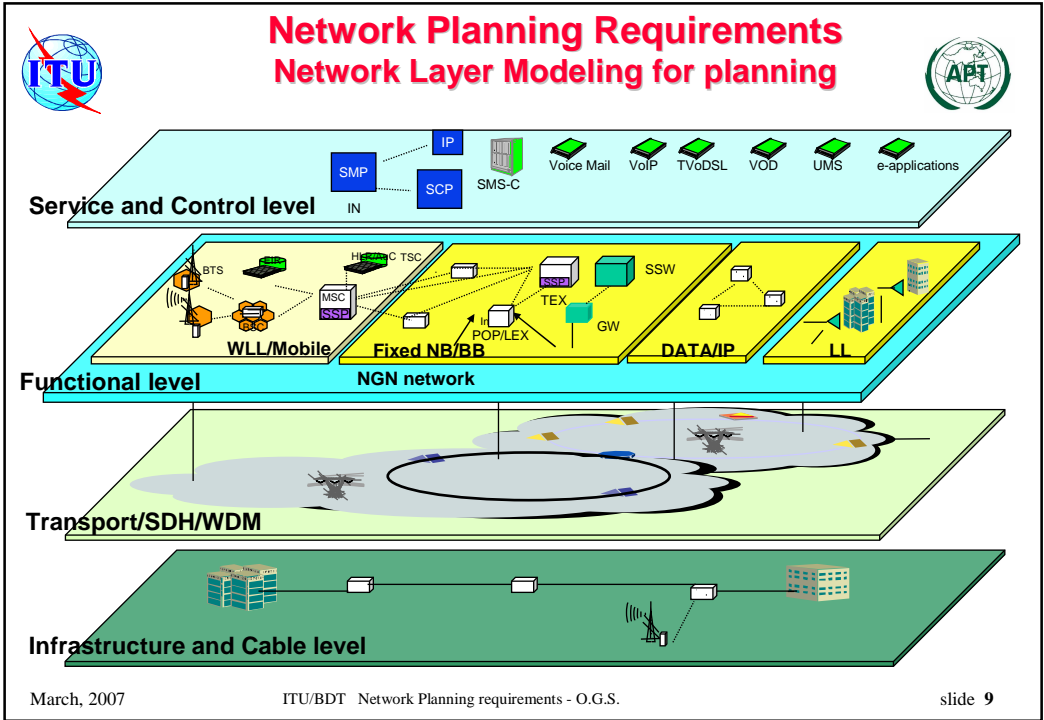



Network Planning Requirements Planning activities

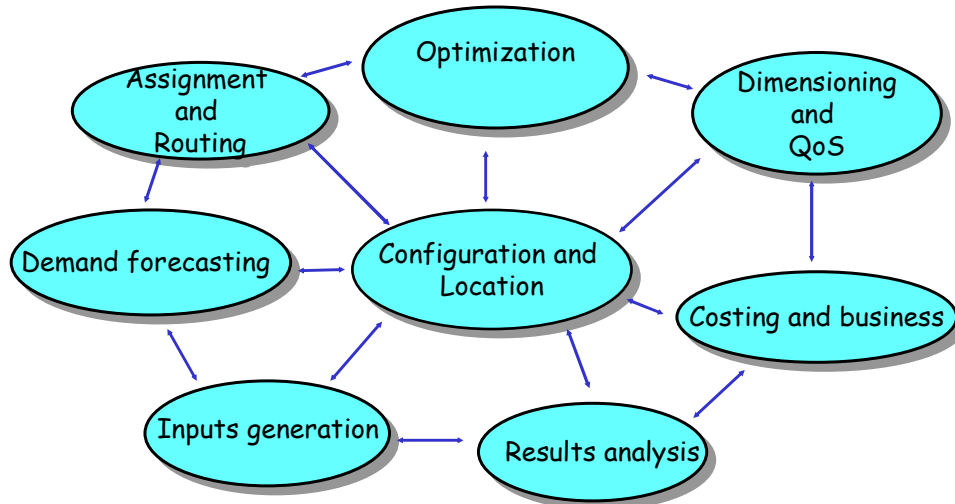

March, 2007

ITU/BDT Network Planning requirements - O.G.S.

slide 11



Network Planning Requirements Network Planning Domains

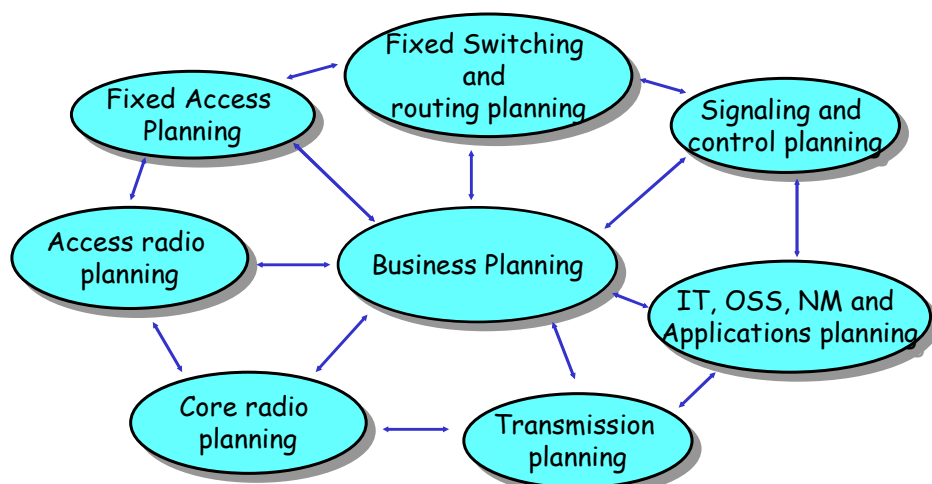

March, 2007

ITU/BDT Network Planning requirements - O.G.S.

slide 12



Network Planning Requirements Planning: Main supporting pillars



NETWORK PLANNING METHODOLOGY

Market and demand
forecasting

Teletraffic
Methodology

Economical
Engineering

Operational Research
and optimization

Architecture and
Technology Know-
How

March, 2007

ITU/BDT Network Planning requirements - O.G.S.

slide 13



Network Planning Requirements Scope: Main supporting pillars



NETWORK PLANNING METHODOLOGY

Teletraffic
Methodology

- Statistical flow modeling for arrival rates and holding times
- Capacity models based on stochastic processes: Analytical and Simulation
- Dimensioning based on efficiency, performance and QoS
- Good foundation on the multiple contributions from the International Teletraffic community (ITC)

March, 2007

ITU/BDT Network Planning requirements - O.G.S.

slide 14



Network Planning NGN and IMS Content



- Role of Network Planning
 - Requirements
 - Domains and methodology
- Network design issues in NGN
- Strategic Planning and Technology mapping



Network Planning Requirements Modeling issues for NGN and 3G



- New models to represent multiservice flows
- New dimensioning methods for resources handling multimedia services with QoS
- New measurement procedures for aggregated multiservice traffics
- New multicriteria dimensioning for 3G and xG combining coverage by frequency, service speed and data traffic capacity
- Which procedures to ensure interoperability and end-to-end performance across multiple domains?
- Which units to define dimensioning and costing units for interconnection?



Network Planning Requirements QoS and Performance Issues



- Quality of Service (QoS) domains to be modeled, defined and/or extended for NGN and 3G. Measured in waiting time and/or loss probabilities
- Domains for QoS evaluation:
 - **Service accessibility**: capability to access a service
 - **Connection establishment**: Capability to get connection
 - **Information transfer**: Quality of information delivery
 - **Reliability**: Failure probability
 - **Availability**: Probability of system being active
 - **Survivability**: Capability to provide service in abnormal conditions
 - **Security**: Information and systems protection level
 - **Qualitative**: Intelligibility, audibility, visualization ... of information content as derived from user perception (MOS)



Network Planning Requirements Traffic flows for QoS based dimensioning



- **T1) QoS constant stream**: bandwidth transmission at a constant speed with a specified delivery and jitter (ie: video distribution)
- **T2) QoS variable stream** : bandwidth transmission at a variable speed derived from a user information and coding algorithm which requires guaranteed quality and specified jitter (ie: VoIP, Video streaming, audio streaming, etc.)
- **T3) QoS elastic**: bandwidth transmission at a variable speed without jitter restrictions and asynchronous delivery (ie: browsing, file transfer, mail, UMS, etc.)



Network Planning Requirements Performance Issues: case of VoIP



Perceived Quality of Service as a function of the number of crossed domains for the G.711+PLC coding with ppp = .01 and gold /silver SLA (19th International Teletraffic Congress September 2005, Beijing)

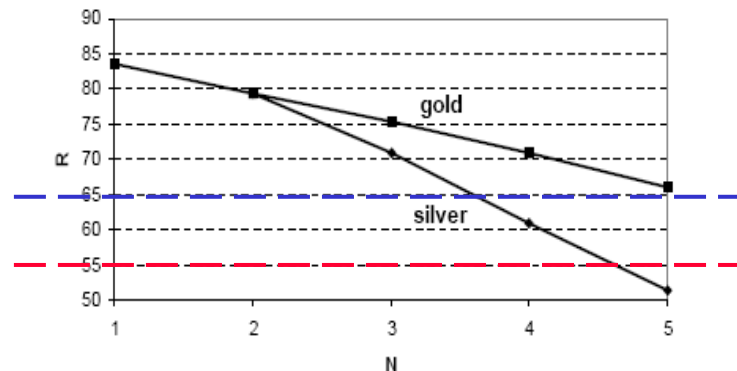

High importance of the number of crossed domains and quality per domain on the end-to-end performance

March, 2007

ITU/BDT Network Planning requirements - O.G.S.

slide 19



Network Planning Requirements How to define dimensioning and costing units for interconnection ?



- Requirements for service flow units to be used:
 - Should be **quantifiable** with defined engineering rules
 - Useful for interrelation between **demand/dimensioning/costing** for a given QoS and SLA
 - Reflecting **service provisioning** and market value across multiple networks
 - Applicable to **multiservice/multimedia flows**

March, 2007

ITU/BDT Network Planning requirements - O.G.S.

slide 20



Network Planning Requirements

Traffic units for aggregated flows



Proposal of NGN units in multiservice networks/interfaces for demand/dimensioning/costing :

- Equivalent Sustained Bit Rate (ESBR) or aggregated equivalent rates for same QoS category flows efficiently carried in a common reference busy period (ie. 5 minutes)
- Computed as weighted average for the services at QoS category (i) and customer classes (j) at each network element:
$$\sum_i \sum_j \text{ESBR}_{ij}$$



Network Planning NGN and IMS

Content



- Role of Network Planning
 - Requirements
 - Domains and methodology
- Network design issues in NGN
- Strategic Planning and Technology mapping



Network Planning Requirements Solution Mapping



Solution mapping is more important today as the number of technologies and network options increase

- Large variety of geo-scenarios within the country
 - Geography
 - User profiles
 - Density
 - Economy
- Alternatives modeled with all key parameters that characterize scenario, services, demands and solutions
- Best solutions selected based on techno-economical evaluation and resulting best Cost of Ownership

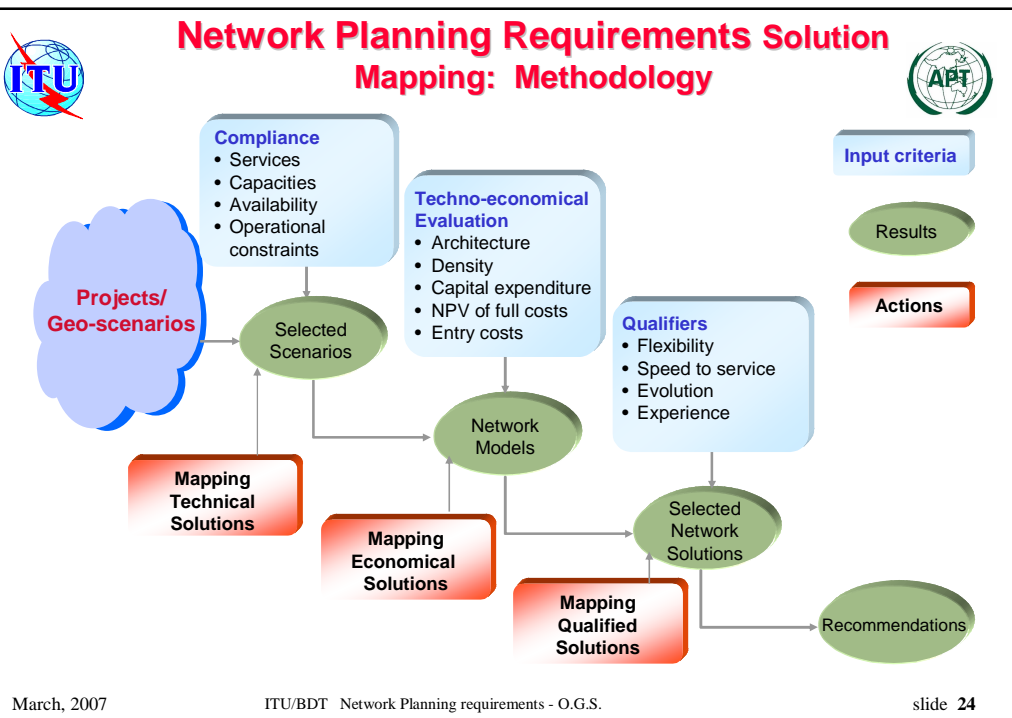



Network Planning Requirements Solution Mapping: Cost Modeling

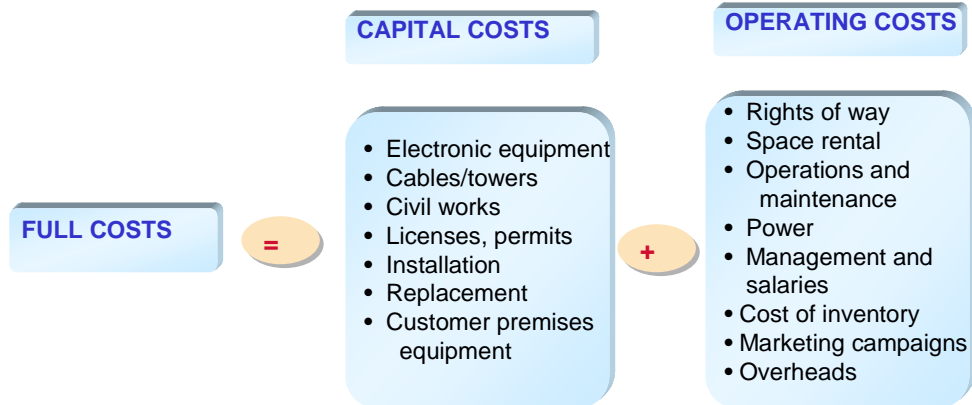

March, 2007

ITU/BDT Network Planning requirements - O.G.S.

slide 25



Network Planning Requirements Solution Mapping: Example of Geo Scenarios

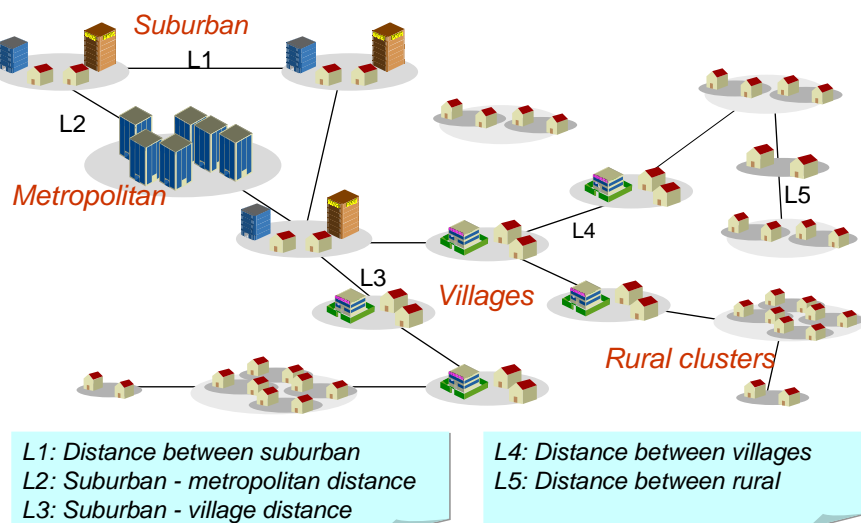

March, 2007

ITU/BDT Network Planning requirements - O.G.S.

slide 26



Network Planning Requirements Solution Mapping: Technological alternatives at access (Fixed)

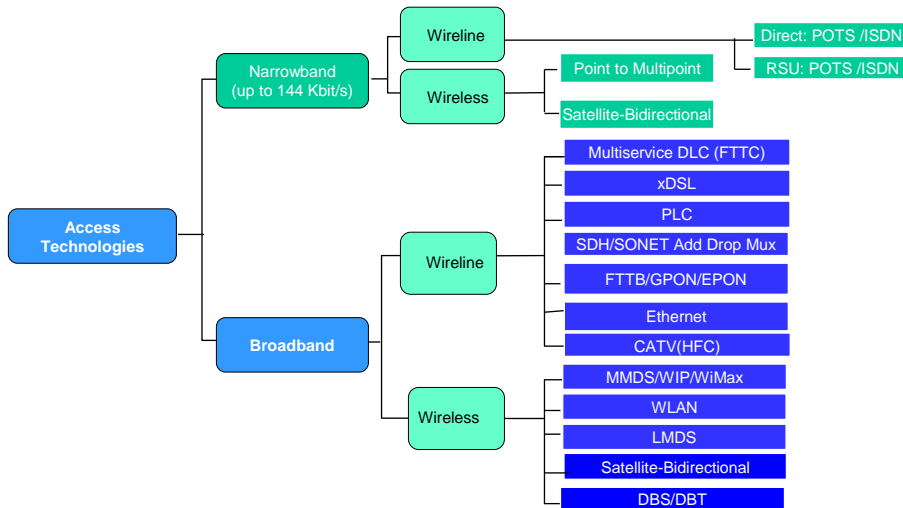

March, 2007

ITU/BDT Network Planning requirements - O.G.S.

slide 27



Network Planning Requirements Solution Mapping: Investment sensitivity to density in WL Access



High density areas

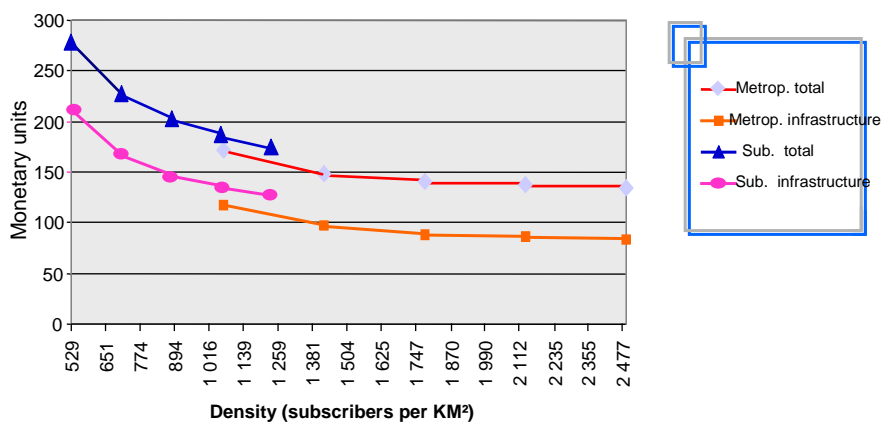

March, 2007

ITU/BDT Network Planning requirements - O.G.S.

slide 28



Network Planning Requirements Example of mapping recommendation

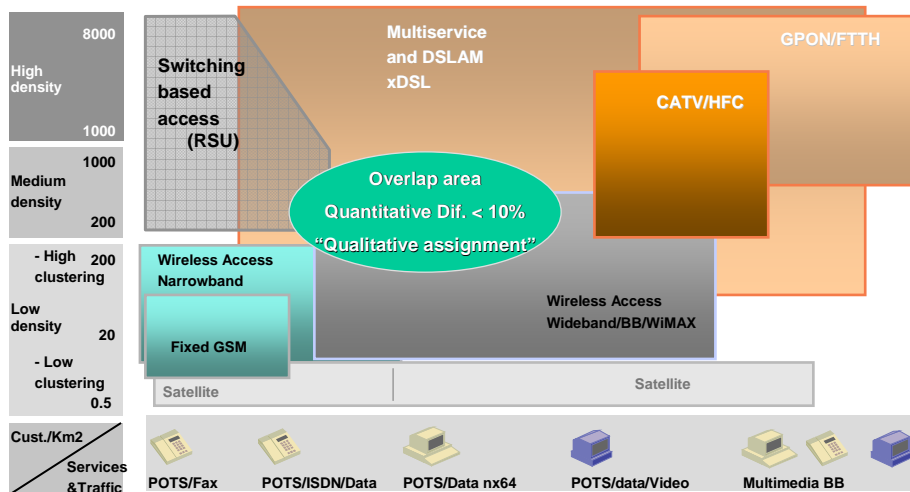

March, 2007

ITU/BDT Network Planning requirements - O.G.S.

slide 29



Network Planning Requirements Benefits of mapping and planning activities



- Saving factors of 20 to 200 % by adequate solution/technology mapping in the access segment
- Additional gains between 20 to 40 % by topology/routing optimization
- Anticipation of 2 to 3 years in the positive IRR
- Assure fulfillment of SLA and QoS
- Positioning of the operator in the top competition levels

March, 2007

ITU/BDT Network Planning requirements - O.G.S.

slide 30



Network Planning Requirements Summary of Key Requirements



- **Multiservice flows** impose a set of requirements on models and tools for NGN and 3G.
- **Interoperability and interconnection** require special effort to players and planners to ensure end-to-end performance
- High number of new technologies and capabilities reinforce the need of **solution mapping** for each country scenario
- Complexity of converged networks require the use of **high quality support tools**