



ITU / BDT workshop

Bangkok, Thailand,

11 – 15 November 2002

Network Planning

Lecture NP- 2.4

Network Architectures and Technologies



BDT - COE workshop on Network Planning

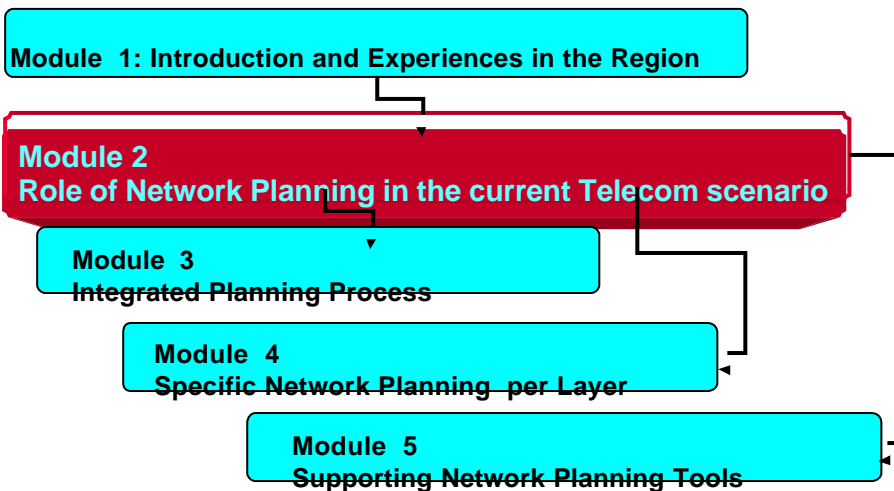



Content Chapter 2.4

Network Architectures and Technologies

- **Modeling of the network by layers and segments for planning purposes**
- **Technology alternatives for today's telecom networks**
- **Access and Core architectures and solutions**
- **NGN: What and how**



Network Architectures and Technologies: Network Modeling

- **High complexity of the whole Network requires a modeling and splitting in subnetworks to facilitate analysis and design.**
 - **By Layers** in a vertical dimension following the client-server relation (one layer is supported in the layer below and provides resources for the layer up). **Physical, Transmission, Switching, etc.**
 - **By Segments** or splitting of the end to end communication into subareas as **customer premises, access, core national, core international**
 - **By Technologies** or underlying technique as **PDH, SDH, PSTN, ATM, IP, GSM, etc.....**
- **Network Planning follows the same splitting or partitioning to allow treatment of the problems and adaptation to associated**



Network Architectures and Technologies: Network Layer Modeling

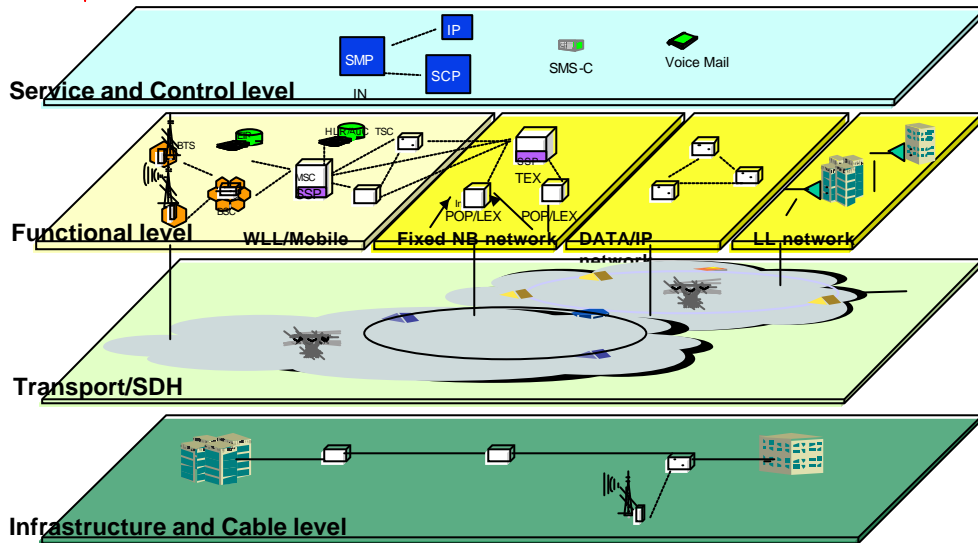

November 12th

ITU/BDT Network Planning/ Architectures - O.G.S.

Lecture NP - 2.4 - slide 5



Network Architectures and Technologies: Network Segment Modeling

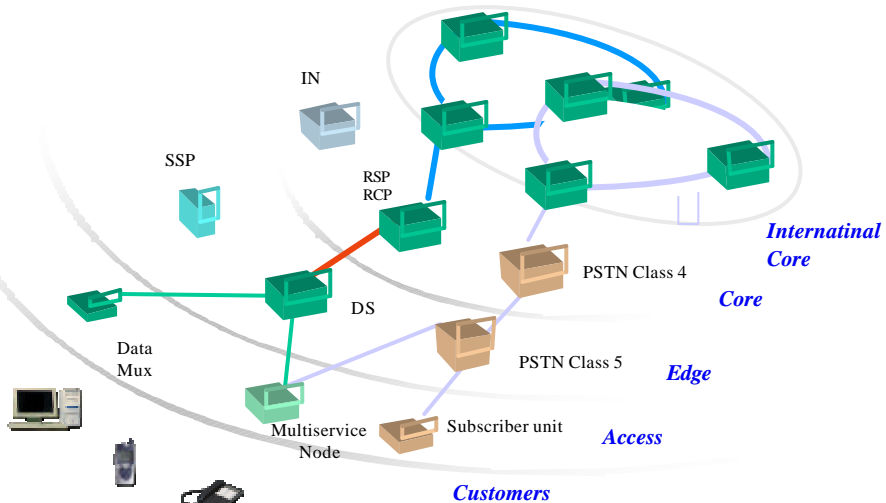

November 12th

ITU/BDT Network Planning/ Architectures - O.G.S.

Lecture NP - 2.4 - slide 6



Network Architectures and Technologies: Topologies

- **Meshed (direct connection among nodes)**

- Fully (for all network nodes)
- Partial (with limited connectivity)

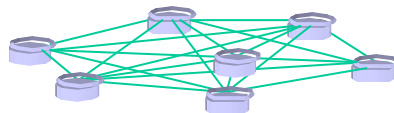

- **Ring**

- Single, Multiple, Folded

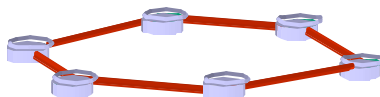

- **Star**

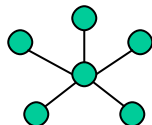

- **Tree**

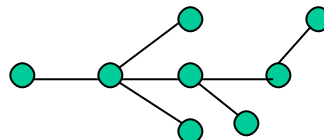

- **Linear**

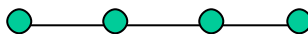

- **Combined**

November 12th

ITU/BDT Network Planning/ Architectures - O.G.S.

Lecture NP - 2.4 - slide 7



Access Network Architecture: Wireline

Typical Access Network structure

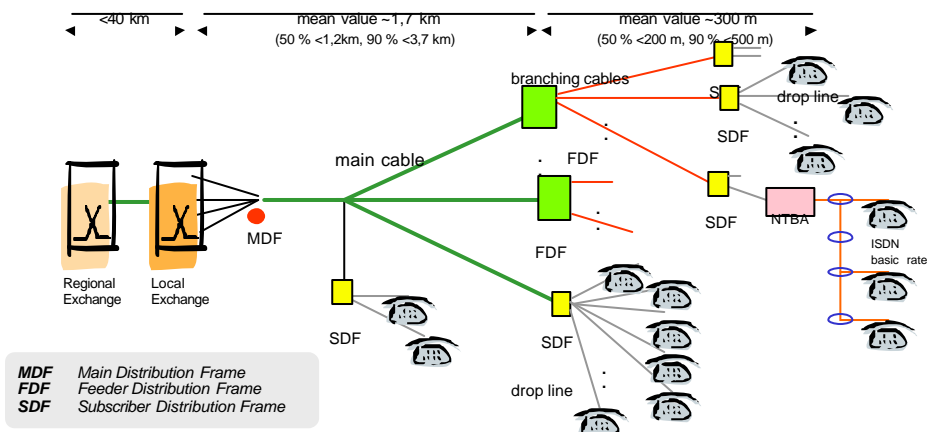

November 12th

ITU/BDT Network Planning/ Architectures - O.G.S.

Lecture NP - 2.4 - slide 8



Access Network Architecture: Wireline Evolution

Typical Access Network evolution

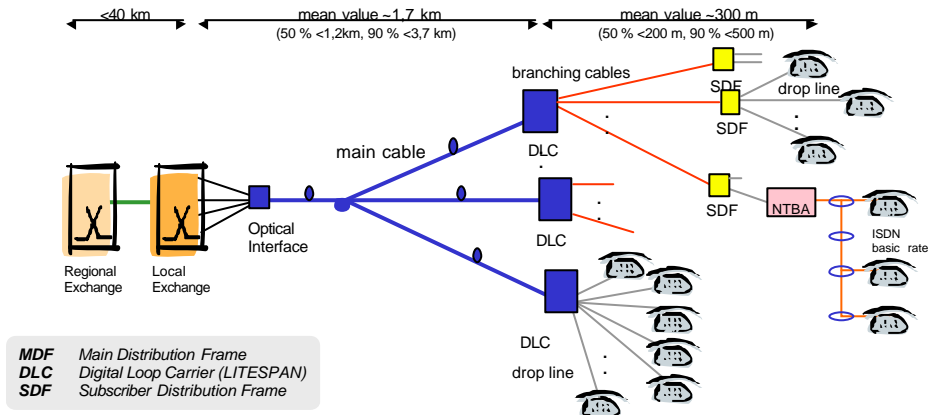

Access Network Architecture: LMDS

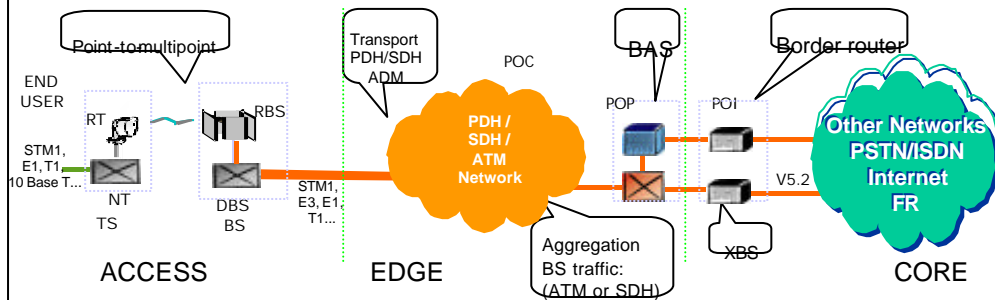

RT: Radio Termination
 NT: Network Termination
 TS: Terminal Station

BS: Base Station
 DBS: Digital Base Station
 RBS: Radio Base Station
 XBS: Exchange Base Station

POC: Point of Concentration
 POP: Point of presence
 POI: Point of Interconnection
 BAS: Broadband Access Server



Access Network Architecture: WIP

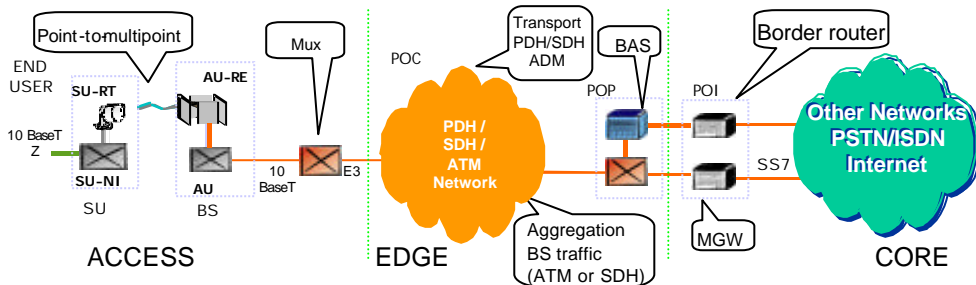

SU: Subscriber Unit
 SU-RT: Subscriber Unit Outdoor Unit
 SU-NI: Subscriber Unit Indoor Unit

BS: Base Station
 AU: Access Unit
 AU-RE: Radio Front-end
 MGW: Media Gateway

POC: Point of Concentration
 POP: Point of presence
 POI: Point of Interconnection
 BAS: Broadband Access Server

Note: The current Network description shows the ATM approach (BAS is needed). A fully IP scenario is also feasible (BAS is not needed)



Access Network Architecture: HFC

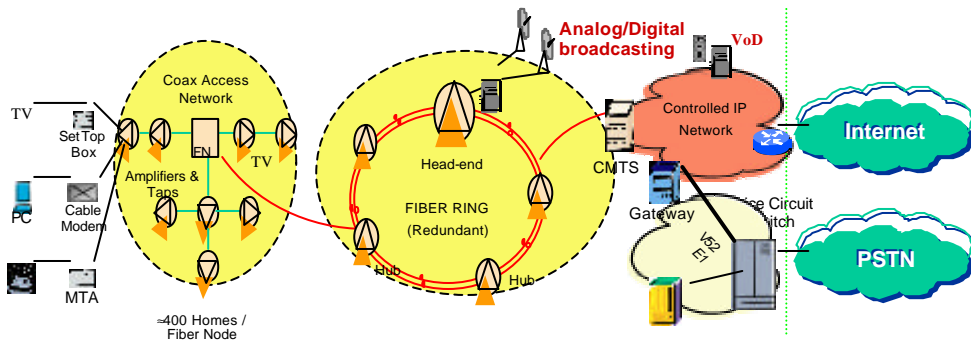

MTA: Multimedia Terminal Adapter
 FN: Fiber Node
 CMTS: Cable Modem Termination System
 VoD: Video on Demand
 IN: Intelligent Network



Access Network Architecture: xDSL

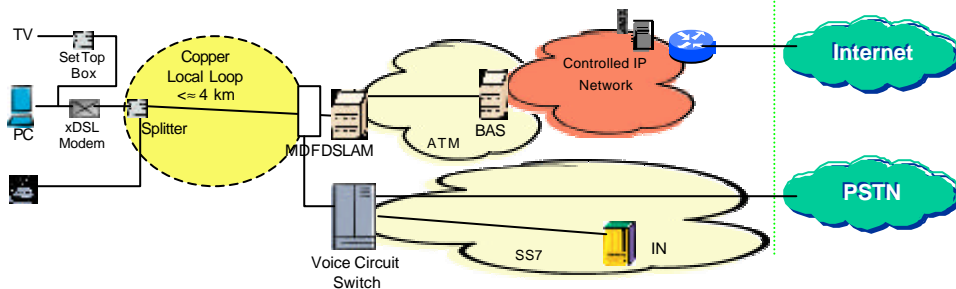

MDF: Main Distribution Frame
DSLAM: Digital Subscriber Line Access Multiplexer
IN: Intelligent Network
BAS: Broadband Access Server

November 12th

ITU/BDT Network Planning/ Architectures - O.G.S.

Lecture NP - 2.4 - slide 13



Access Network Architecture: Multiservice DLC

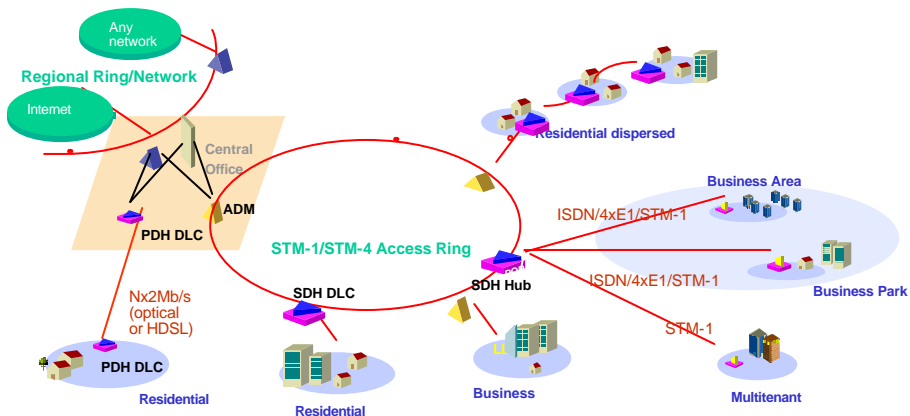

DLC: Digital Loop Carrier

November 12th

ITU/BDT Network Planning/ Architectures - O.G.S.

Lecture NP - 2.4 - slide 14



Access Network Architecture: FTTU

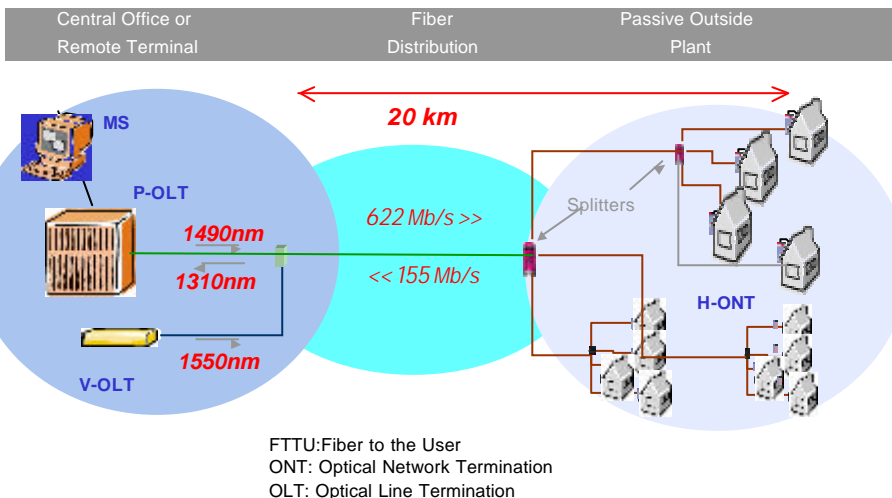

November 12th

ITU/BDT Network Planning/ Architectures - O.G.S.

Lecture NP - 2.4 - slide 15



Network Architectures and Technologies: Technological alternatives at core

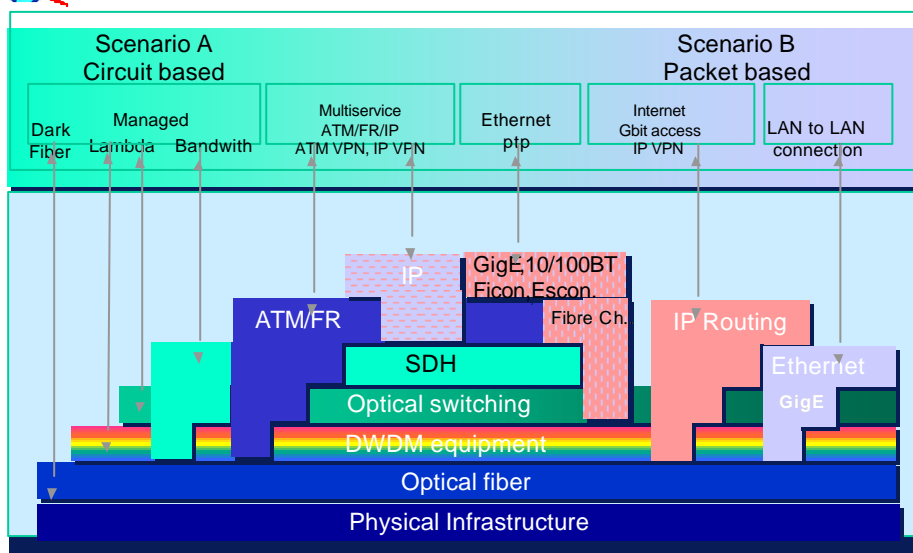

November 12th

ITU/BDT Network Planning/ Architectures - O.G.S.

Lecture NP - 2.4 - slide 16



Multi-Layering in Transport Networks: Sub-layer relations

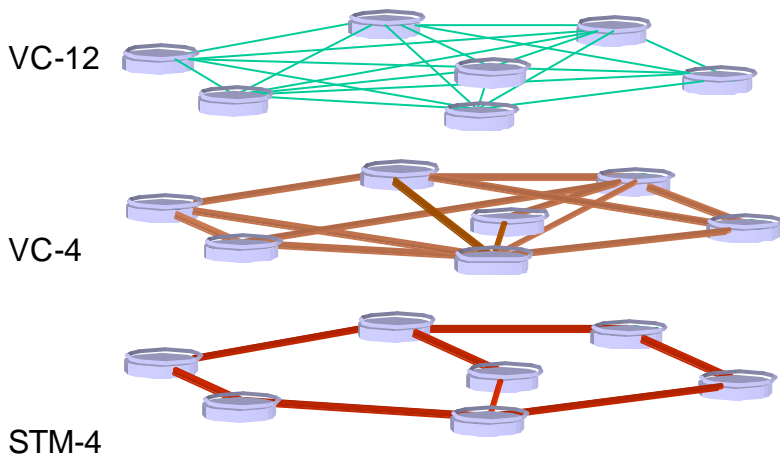

November 12th

ITU/BDT Network Planning/ Architectures - O.G.S.

Lecture NP - 2.4 - slide 17



Multi-Layering in Transport Networks: Sub-layers composition

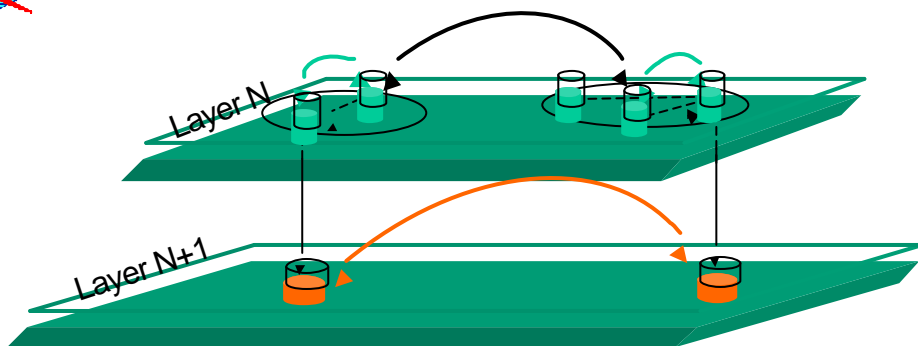

- Initial sub-layer N relation
- Composed sub-layer N+1 relation
- Composed sub-layer N relation

November 12th

ITU/BDT Network Planning/ Architectures - O.G.S.

Lecture NP - 2.4 - slide 18



Multi-Layering in Transport Networks: Introduction of WDM

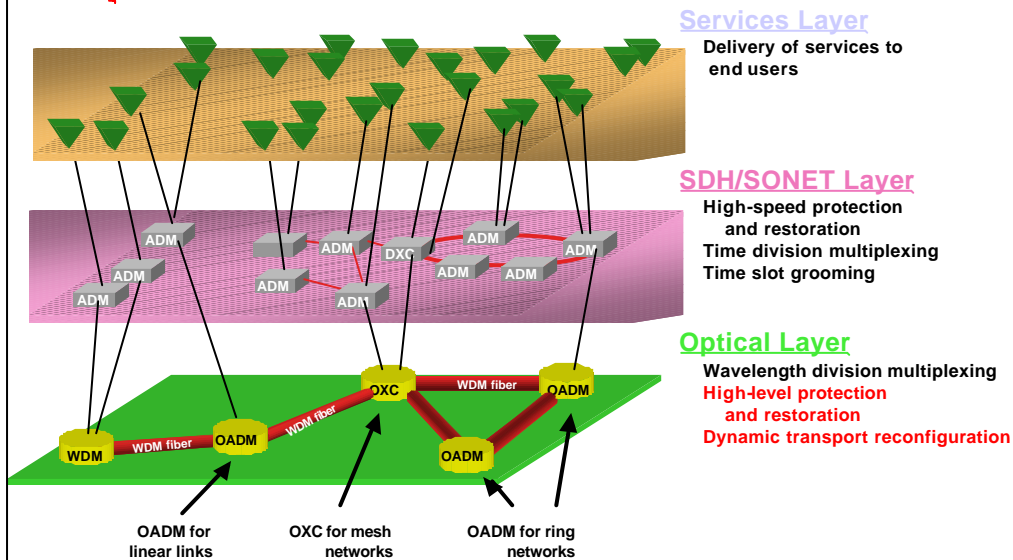

November 12th

ITU/BDT Network Planning/ Architectures - O.G.S.

Lecture NP - 2.4 - slide 19



Transmission Network Architecture: ADM Network Elements

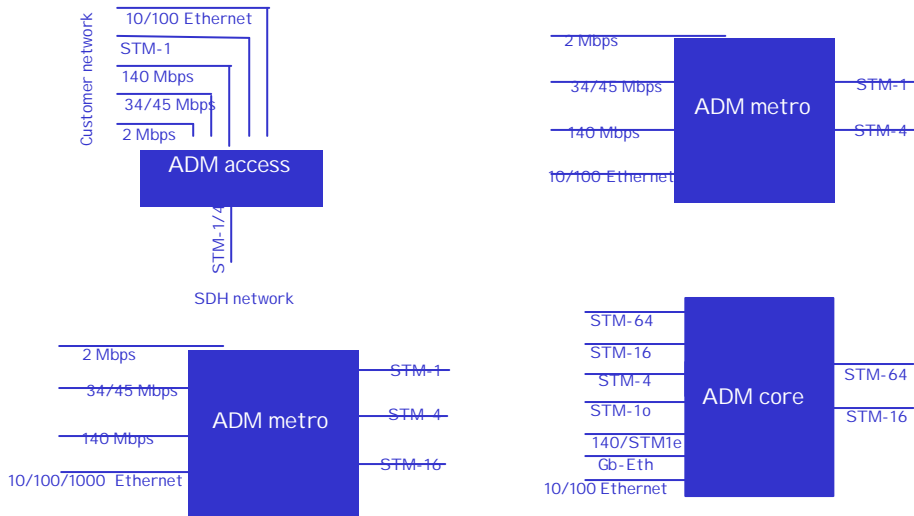

November 12th

ITU/BDT Network Planning/ Architectures - O.G.S.

Lecture NP - 2.4 - slide 20



Network Architectures and Technologies: Trends in Transport Technology

TODAY

Point-to-Point DWDM
for backbone capacity

Predetermined
Bandwidth Re-allocation

Network Design Specific to
Type of Service Provided

Protection Provided Mainly
by Sonet/SDH Layer



TOMORROW

Intelligent Optical Networks
for end-to-end service

Fast and efficient
On-demand bandwidth

Multi-Service Optimized
Network (IP/ATM/TDM)

Optical Layer Protection

- independent of service type
- adaptable to class of service



Network Architectures and Technologies: Evolution towards NGN

NGN concept

- A **multi-service network** able to support voice, data and video
- A network with a control plane (signaling, control) **separated** from the transport/switching plane
- A network with **open interfaces** between transport, control and applications
- A network using **packet technology** (ATM, IP) to transport of all kind of information
- A network with **guaranteed QoS** for different traffic types



Network Architectures and Technologies: Evolution towards NGN

NGN layers

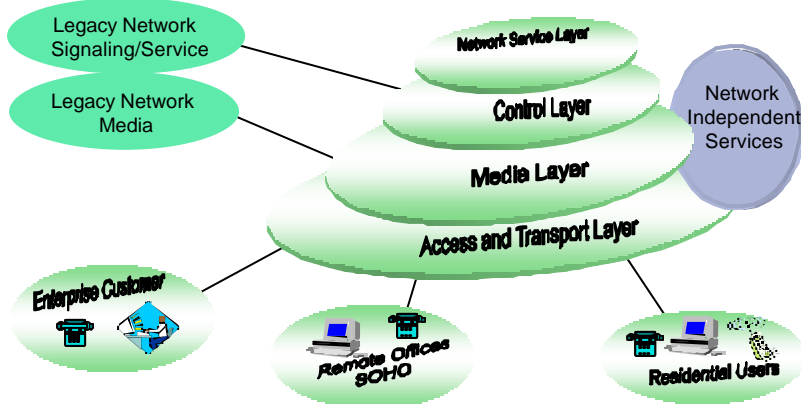

November 12th

ITU/BDT Network Planning/ Architectures - O.G.S.

Lecture NP - 2.4 - slide 23



Network Architectures and Technologies: Evolution towards NGN

NGN : Why

- **Flexibility** for service building and offering
- Expectation of **cost reductions** by sharing infrastructure and systems
- **Simplification of O&M**, thus lowering OPEX.
- Use of **open interfaces** leads for:
 - quick deployment of services and applications
 - new services (third parties)

November 12th

ITU/BDT Network Planning/ Architectures - O.G.S.

Lecture NP - 2.4 - slide 24



Network Architectures and Technologies: Evolution towards NGN

NGN : Issues today

- Availability for all the functionalities within a public environment and carrier-grade service still needing some time
- QoS guarantee for high priority flows subject to limitations and standardization
- Routing procedures for guaranteed flows (MPLS, GMPLS) in evolution and not common through different suppliers, networks and domains
- Processing capacity limitations when all functions and flows are carried in large networks



Network Architectures and Technologies: Evolution towards NGN

Today: Overlay Networks for Basic PSTN & Internet access

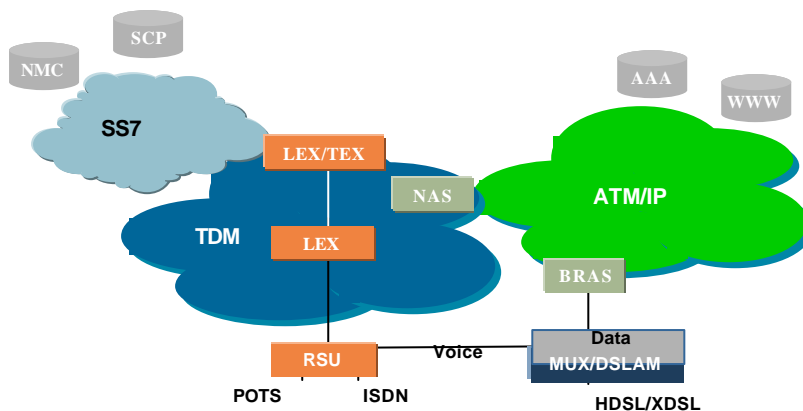



Network Architectures and Technologies: Evolution towards NGN

First Step: Network consolidation & access optimization

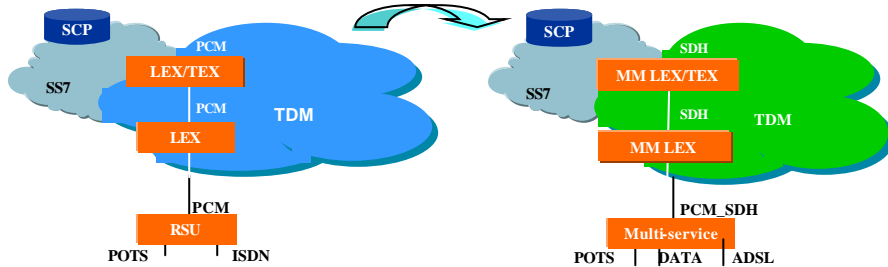

- Low capacity (2000 PCM)
- TDM switching matrix
- Overwhelming data traffic



- Higher capacity (16.000 PCM)
- ATM switching matrix (80 Gbit/s)
- SDH-STM1 interfaces
- Data and ADSL integrated in the Multi-service access
- OPEX & CAPEX optimization

November 12th

ITU/BDT Network Planning/ Architectures - O.G.S.

Lecture NP - 2.4 - slide 27



Network Architectures and Technologies: Evolution towards NGN

Second Step: Smooth migration to NGN

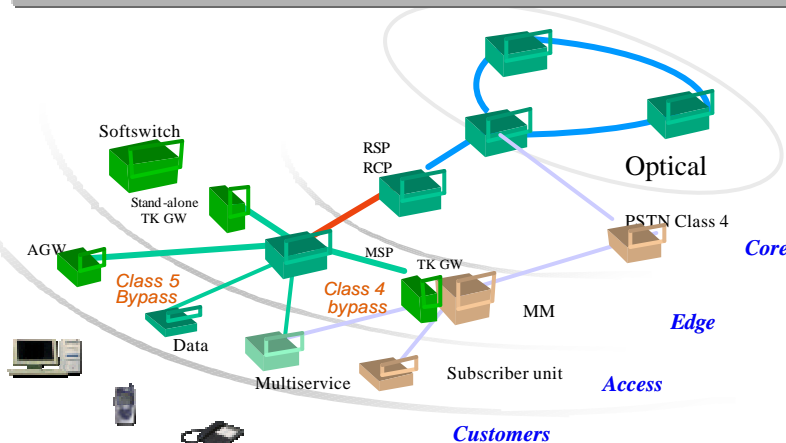

November 12th

ITU/BDT Network Planning/ Architectures - O.G.S.

Lecture NP - 2.4 - slide 28



Network Architectures and Technologies: Evolution towards NGN

Target : Converged networks

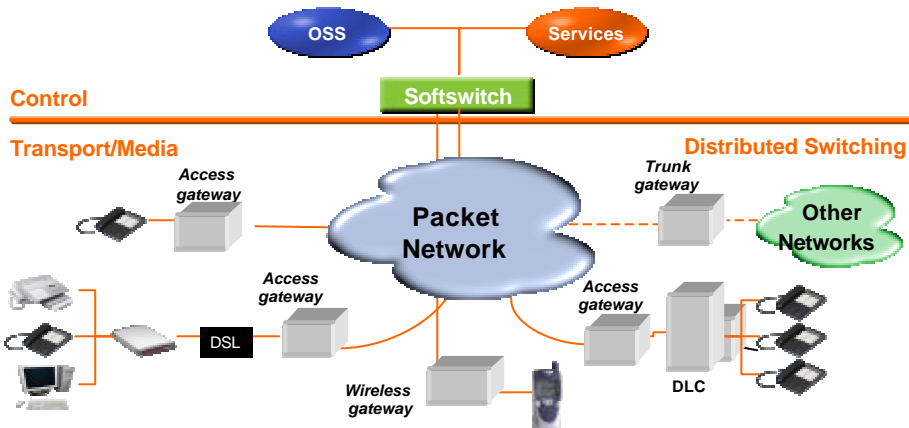

November 12th

ITU/BDT Network Planning/ Architectures - O.G.S.

Lecture NP - 2.4 - slide 29



Network Architectures and Technologies: Evolution towards NGN

NGN : Recommendations

- Ready to be applied in private multiservice data networks
- Ready for public data networks to integrate different data applications
- Optional for “small” alternative operators and multiservice environment
- Careful planning for operators with existing infrastructure and operations

November 12th

ITU/BDT Network Planning/ Architectures - O.G.S.

Lecture NP - 2.4 - slide 30