



INTERNATIONAL TELECOMMUNICATION UNION
Telecommunications Development Bureau (BDT)

Regional Seminar on evolving network infrastructures to NGN and related Planning Strategies and Tools

Belgrade, 20-24 June 2005

Network Evolution to NGN

2.1 a

Riccardo Passerini, ITU-BDT

ITU-BDT Regional Seminar for Africa on Fixed Mobile Convergence and Guidelines on the smooth transition of existing mobile network to IMT-2000, Nairobi 9-12 May 05 -RP



Evolution Architecture

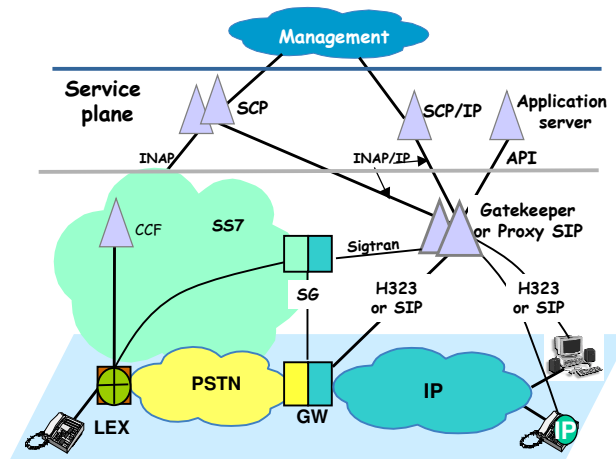

→ IP can be considered as a "Data NGN"

ITU-BDT Regional Seminar for Africa on Fixed Mobile Convergence and Guidelines on the smooth transition of existing mobile network to IMT-2000, Nairobi 9-12 May 05 -RP



Network capabilities to support “IP telephony” interworking between the PSTN and the IP network

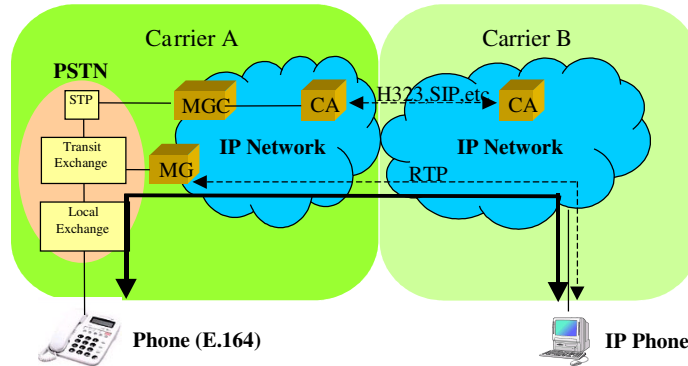

Network configuration connecting carriers (NNI between IP-IP network)

ITU-BDT Regional Seminar for Africa on Fixed Mobile Convergence and Guidelines on the smooth transition of existing mobile network to IMT-2000, Nairobi 9-12 May 05 -RP

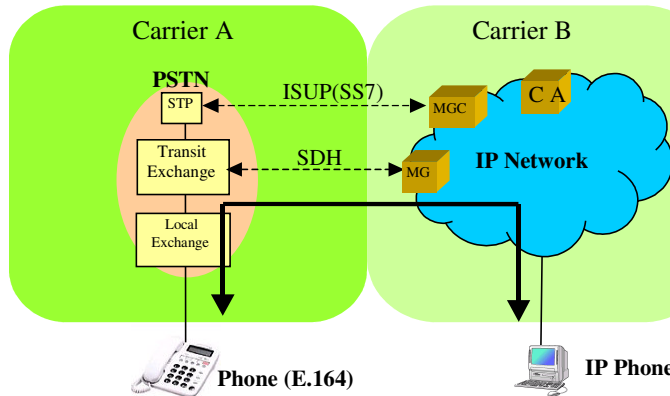

Network configuration connecting carriers (NNI between PSTN-IP network)

ITU-BDT Regional Seminar for Africa on Fixed Mobile Convergence and Guidelines on the smooth transition of existing mobile network to IMT-2000, Nairobi 9-12 May 05 -RP



Control Protocols for support of “IP telephony”

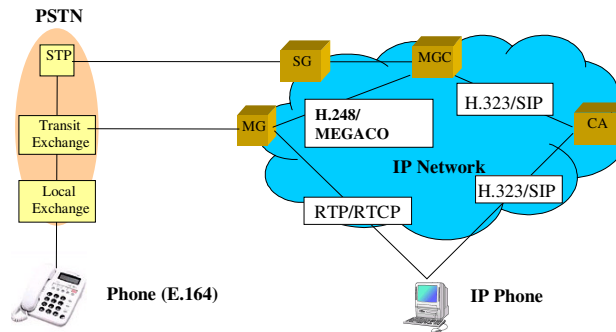

Example of protocol adoption

ITU-BDT Regional Seminar for Africa on Fixed Mobile Convergence and Guidelines on the smooth transition of existing mobile network to IMT-2000, Nairobi 9-12 May 05 -RP



TERMS AND DEFINITIONS

Media Gateway (MG): A media gateway converts the media provided by one type of network to the format required by another type of network. Terminates voice calls on inter-switch trunks from the PSTN, compresses and packetizes the voice data, and delivers compressed voice packets to the IP network. For voice calls originating in an IP network, the media gateway performs these functions in reverse order.

Media Gateway Controller (MGC): Controller that controls the parts of the call state that pertain to connection control for the media channels within a media gateway. A media gateway controller handles the registration and management of resources at the media gateway(s). A media gateway controller exchanges ISUP messages with central-office switches via a signalling gateway (described below). Because vendors of media gateway controllers often use off-the-shelf computer platforms, a media gateway controller is sometimes called a softswitch.

Signalling Gateway (SG): A signalling gateway provides transparent interworking of signalling between switched-circuit and IP networks. The signalling gateway may terminate PSTN/SS7 signalling or relay messages over an IP network to a media gateway controller or another signalling gateway. Because of its critical role in integrated voice networks, signalling gateways are often deployed in groups of two or more to ensure high availability

Call Agent (CA): Function that controls the provision of services to users.

ITU-BDT Regional Seminar for Africa on Fixed Mobile Convergence and Guidelines on the smooth transition of existing mobile network to IMT-2000, Nairobi 9-12 May 05 -RP



General overview of NGN: ITU-T Recommendation Y 2001 (12/2004)

The concept of an NGN (Next Generation Network) has been introduced to take into consideration the new realities in the telecommunications industry, characterized by factors such as: competition among operators due to ongoing deregulation of markets, explosion of digital traffic, e.g., increasing use of "the Internet", increasing demand for new multimedia services, increasing demand for a general mobility, convergence of networks and services, etc. The NGN (Next Generation Network) is conceived as a concrete implementation of the GII (Global Information Infrastructure).

The target of NGN is to ensure that all elements required for interoperability and network capabilities support applications globally across the NGN while maintaining the concept of separation between transport, services and applications.

A major goal of the NGN is to facilitate convergence of networks and convergence of services. The common understanding is that the NGN has to be seen as the concrete realization of concepts defined for the GII

ITU-BDT Regional Seminar for Africa on Fixed Mobile Convergence and Guidelines on the smooth transition of existing mobile network to IMT-2000, Nairobi 9-12 May 05 -RP



General overview of NGN: ITU-T Recommendation Y 2001 (12/2004)

3.1 Next Generation Network (NGN): A packet-based network able to provide telecommunication services and able to make use of multiple broadband, QoS-enabled transport technologies and in which service-related functions are independent from underlying transport-related technologies. It enables unfettered access for users to networks and to competing service providers and/or services of their choice. It supports generalized mobility which will allow consistent and ubiquitous provision of services to users.

3.2 generalized mobility: The ability for the user or other mobile entities to communicate and access services irrespective of changes of the location or technical environment. The degree of service availability may depend on several factors including the Access Network capabilities, service level agreements between the user's home network and the visited network (if applicable), etc. Mobility includes the ability of telecommunication with or without service continuity.

ITU-BDT Regional Seminar for Africa on Fixed Mobile Convergence and Guidelines on the smooth transition of existing mobile network to IMT-2000, Nairobi 9-12 May 05 -RP



Objectives of the NGN

NGN should fulfil the requirement of the environment described in ITU-T Recs Y.100 [1], Y.110 [2], Y.130 [3] and Y.140 [4] or Y.140.1 [5], for example to:

- **promote fair competition;**
- **encourage private investment;**
- **define a framework for architecture and capabilities to be able to meet various regulatory requirements;**
- **provide open access to networks;**

while:

- **ensuring universal provision of and access to services;**
- **promoting equality of opportunity to the citizen;**
- **promoting diversity of content, including cultural and linguistic diversity;**
- **recognizing the necessity of worldwide cooperation with particular attention to less developed countries.**

ITU-BDT Regional Seminar for Africa on Fixed Mobile Convergence and Guidelines on the smooth transition of existing mobile network to IMT-2000, Nairobi 9-12 May 05 -RP



Fundamental characteristics of NGN (1)

The term NGN as defined in clause 3 is commonly used to give a name to the changes to the service provision infrastructures that have already started in the telecommunication industry. The NGN can be further defined by the following fundamental characteristics:

- **packet-based transfer;**
- **separation of control functions among bearer capabilities, call/session, and application/ service;**
- **decoupling of service provision from transport, and provision of open interfaces;**
- **support for a wide range of services, applications and mechanisms based on service building blocks (including real time/ streaming/ non-real time and multimedia services);**
- **broadband capabilities with end-to-end QoS (Quality of Service);**

ITU-BDT Regional Seminar for Africa on Fixed Mobile Convergence and Guidelines on the smooth transition of existing mobile network to IMT-2000, Nairobi 9-12 May 05 -RP



Fundamental characteristics of NGN (2)

- interworking with legacy networks via open interfaces;
- generalized mobility (see 3.2 and 8.7);
- unrestricted access by users to different service providers;
- a variety of identification schemes;
- unified service characteristics for the same service as perceived by the user;
- converged services between fixed/mobile;
- independence of service-related functions from underlying transport technologies;
- support of multiple last mile technologies;
- compliant with all regulatory requirements, for example concerning emergency communications, security, privacy, lawful interception, etc.

ITU-BDT Regional Seminar for Africa on Fixed Mobile Convergence and Guidelines on the smooth transition of existing mobile network to IMT-2000, Nairobi 9-12 May 05 -RP



NGN capabilities (1)

NGN shall provide the capabilities (infrastructure, protocols, etc.) to make the creation, deployment and management of all kinds of services (known or not yet known) possible

One of the main characteristics of NGN is the decoupling of services and transport, allowing them to be offered separately and to evolve independently. Therefore in the NGN architectures, there shall be a clear separation between the functions for the services and the functions for the transport. NGN allows the provisioning of both existing and new services independently of the network and the access type used.

Interworking between NGNs of different operators and between NGN and existing networks such as PSTN (Public Switched Telephone Network), ISDN (Integrated Services Digital Network) and GSM (Global System for Mobile communications) is provided by means of gateways.

ITU-BDT Regional Seminar for Africa on Fixed Mobile Convergence and Guidelines on the smooth transition of existing mobile network to IMT-2000, Nairobi 9-12 May 05 -RP



NGN capabilities (2)

NGN will support both existing and "NGN aware" end terminal devices. Hence terminals connected to NGN will include analogue telephone sets, fax machines, ISDN sets, cellular mobile phones, GPRS (General Packet Radio Service) terminal devices, SIP [13] (Session Initiation Protocol) terminals, Ethernet phones through PCs (Personal Computers), digital set top boxes, cable modems, etc.

Specific issues include the migration of voice services to the NGN infrastructure, **Quality of Service** related to real-time voice services (with guaranteed bandwidth, guaranteed delay, guaranteed packet loss, etc.) as well as Security. NGN should provide the **security mechanisms** to protect the exchange of sensitive information over its infrastructure, to protect against the fraudulent use of the services provided by the Service Providers and to protect its own infrastructure from outside attacks.

ITU-BDT Regional Seminar for Africa on Fixed Mobile Convergence and Guidelines on the smooth transition of existing mobile network to IMT-2000, Nairobi 9-12 May 05 -RP



NGN capabilities (3)

A major feature of NGN will be **generalized mobility**, which will allow a consistent provision of services to a user, i.e., the user will be regarded as a unique entity when utilizing different access technologies, regardless of their types. **Generalized mobility means providing the ability of using different access technologies, at different locations while the user and/or the terminal equipment itself may be in movement allowing users to use and manage consistently their applications/customer services across existing network boundaries.**

At present mobility is used in a limited sense such as movement of user and terminal and **with or without service continuity** to similar public accessed networks (such as WLAN, GSM, UMTS, etc.) and service discontinuity to some wired line accessed networks with strong limitations (such as UPT). **In the future, mobility will be offered in a broader sense** where users may have the ability to use more access technologies, allowing movement between public wired access points and public wireless access points of various technologies. **This means that this movement will not necessarily force an interruption of an application in use or a customer service.**

ITU-BDT Regional Seminar for Africa on Fixed Mobile Convergence and Guidelines on the smooth transition of existing mobile network to IMT-2000, Nairobi 9-12 May 05 -RP



Interactions between NGNs and non-NGN environments

An important aspect of providing seamless operation is the ability of interworking between NGNs, and between NGNs and other networks, such as PSTN.

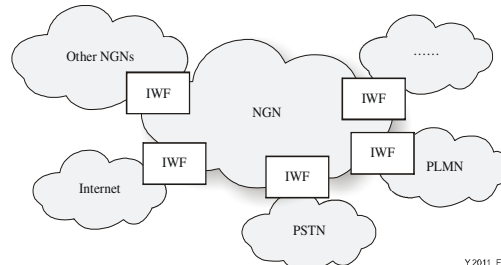

Figure II.1/Y.2011 – Interworking of NGN with other NGNs and legacy networks

It is envisaged that NGN will interwork with other networks to ensure:

- end-to-end communication capabilities for users of such networks as PSTN are preserved;
- content delivery capabilities for users of Internet, TV networks, etc.;
- step-by-step (transitional) deployment of NGN;
- inheritance of rich services from legacy networks.

ITU-BDT Regional Seminar for Africa on Fixed Mobile Convergence and Guidelines on the smooth transition of existing mobile network to IMT-2000, Nairobi 9-12 May 05 -RP



Definitions

- 3.1 **Access Gateway (AG):** A unit that provides subscribers with various service access (e.g. PSTN, ISDN, V5.x, xDSL, LAN etc.) and connects them to the packet node (IP or ATM) of an NGN.
- 3.2 **Access Network (AN):** See Recommendation G.964[x].
- 3.3 **Application:** A structured set of capabilities, which provide value-added functionality supported by one or more services, which may be supported by an API interface.
- 3.4 **Application Server (AS):** A unit that supports service execution, e.g. to control Call Servers and NGN special resources (e.g. media server, message server).
- 3.5 **Call server (CS):** A unit which controls set-up, maintenance, modification and release of a call.
- 3.6 **Customer network:** A telecommunications network belonging to the customer and located in the customer premise(s). The customer network is connected to the user side of an access network
- 3.7 **Evolution to NGN:** A process in which parts of the existing networks are replaced or upgraded to the corresponding NGN components providing similar or better functionality, while maintaining the services provided by the original network. In addition, evolution to NGN will provide extra capabilities to the existing networks.
- 3.8 **Gateway:** A unit that interconnects different networks and performs the necessary translation between the protocols used in these networks.
- 3.9 **Next Generation Network (NGN):** See Recommendation Y.2001 [x].
- 3.10 **Node:** A network element (e.g. switch, router, exchange) providing switching and/or routing capabilities.
- 3.11 **PBX:** See Recommendation G.100
- 3.12 **Public Switched Telephone Network (PSTN):** See Recommendation G.100 [x].
- 3.13 **Signalling Gateway (SG):** A unit that provides signalling conversion between the NGN and the other networks (e.g. STP in SS7).
- 3.14 **Telecommunication service:** See Recommendation F.700 (xx).
- 3.15 **Transit Gateway (TG):** A unit that provides an interface between the packet nodes of the NGN and the circuit switched node of the PSTN for bearer traffic. The TG provides any needed conversion to the bearer traffic.

ITU-BDT Regional Seminar for Africa on Fixed Mobile Convergence and Guidelines on the smooth transition of existing mobile network to IMT-2000, Nairobi 9-12 May 05 -RP



Evolution principles

Evolution to NGN should allow continuation of the existing network capabilities and in addition facilitate implementation of new capabilities.

Evolution to NGN should respect the integrity of services provided by the existing networks and should facilitate introduction of new services.

Considering that provision of NGN is an evolutionary process it is necessary to define a **step-by-step approach leading to the NGN as a target network.**

This approach should consider the following objectives:

- separation of transport, control, management and service functions.
- reduction of cost for the network infrastructure and its maintenance
- maximum reuse of the existing resources
- achieving comparable QoS level as provided in the existing network
- optimum use of the new technologies
- rapid implementation of new services and technologies enabling introduction of new applications
- provision of mechanisms enabling user's full utilisation of the applications and network resources.

ITU-BDT Regional Seminar for Africa on Fixed Mobile Convergence and Guidelines on the smooth transition of existing mobile network to IMT-2000, Nairobi 9-12 May 05 -RP



Abbreviations

AG	Access Gateway
ATM	Asynchronous Transfer Mode
CS	Call Server
FR	Frame Relay
GII	Global information infrastructure
IN	Intelligent Network
IP	Internet Protocol
ISDN	Integrated Services Digital Network
LAN	Local Area Network
LL	Leased Line
NGN	Next Generation Network
PSTN	Public Switching Telecommunication Network
QoS	Quality of Service
SG	Signalling Gateway
SS7	Signalling System number 7
STP	Signalling Transfer Point
TDM	Time Division Multiplexing
TG	Transit Gateway
DSL	Digital Subscriber Line

ITU-BDT Regional Seminar for Africa on Fixed Mobile Convergence and Guidelines on the smooth transition of existing mobile network to IMT-2000, Nairobi 9-12 May 05 -RP



Interworking principles

- **Deployment of interworking points:** During the network planning, the specified interworking points should be set, via which the inter-domain, inter-area or inter-network interworking can be accomplished.
- **Interworking filtering:** Both parties for the interworking should sign an agreement in advance to decide the interworking scope, authentication and authorization mode, and execute the operation management layer commands via policy control to adjust the interworking function.
- **Interworking admission control:** It is necessary to decide whether to allow the interworking call access based on the network resource configurations and the current traffic condition.
- **Protocol interworking:** It is necessary to ensure the interworking among different protocols and the completion of interworking calls.
- **Interworking charging:** The interworking points must have the ability to provide charging information of the incoming and outgoing interworking calls to support the settlement between the interworking parties.

ITU-BDT Regional Seminar for Africa on Fixed Mobile Convergence and Guidelines on the smooth transition of existing mobile network to IMT-2000, Nairobi 9-12 May 05 -RP



Aspects to consider

Network operators will potentially choose a different evolution path depending their actual resources. While considering the **evolution path** it is essential the following aspects be considered:

- **Simplified analysis of the current networks**
- **Management**
- **Signalling**
- **Bearer services**
- **Billing**
- **Leased line provisioning**
- **Security**
- **Services which are required by regulatory bodies**
- **Supplementary services**
- **Technical aspects of naming, numbering, addressing**
- **Access technology evolution**

ITU-BDT Regional Seminar for Africa on Fixed Mobile Convergence and Guidelines on the smooth transition of existing mobile network to IMT-2000, Nairobi 9-12 May 05 -RP



Priorities

Network and service providers may choose different evolution path based on their existing and forecasted resources. This approach may encompass different technologies and have different priorities.

Therefore there is a need to prepare a set of documents to help evolution of the existing networks towards NGN. Taking into consideration that potentially there are different evolution approaches (at least as many as the existing networks), it is crucial to consider items provided in clause 8 for each network and to not violate the evolution and interworking principles described in clauses 6 and 7. The following provides list of networks or technologies which may be considered for evolution.

- PSTN / ISDN
- FR
- ATM
- IPv4
- Mobile Network
- Other scenarios

ITU-BDT Regional Seminar for Africa on Fixed Mobile Convergence and Guidelines on the smooth transition of existing mobile network to IMT-2000, Nairobi 9-12 May 05 -RP



Security considerations

Evolution of network security should allow continuation of the existing network security capabilities and in addition provide new resistance capabilities against new security threats.

Several aspects may be considered:

- Achieving acceptable security level by combination of different layer security methods
- Similar user security experience while evolving networks to NGN
- No over-provision of security measures.

ITU-BDT Regional Seminar for Africa on Fixed Mobile Convergence and Guidelines on the smooth transition of existing mobile network to IMT-2000, Nairobi 9-12 May 05 -RP



Evolution of PSTN/ISDN to NGN

NGN (Next Generation Network) is believed to provide new opportunities for and capabilities to the network and service providers. Considering that existing networks have different life span and vast amount of capital has been spent on them, complete replacement of their components is not considered to be either advisable or possible. So, a phased approach should be considered for evolution of existing networks to NGN.

PSTN/ISDN (Public Switched Telephone Network/Integrated Services Digital Network) being one of the first networks, is considered to be prime candidate for evolution. For PSTN/ISDN evolution to NGN a phased approach is considered

Different evolutionary Scenarios with PSTN/ISDN emulation (adaptation to IP infrastructure) and with PSDN/ISDN simulation (session control over IP interfaces and infrastructure) are presently under consideration in ITU in order to provide reference for the evolution to NGN

ITU-BDT Regional Seminar for Africa on Fixed Mobile Convergence and Guidelines on the smooth transition of existing mobile network to IMT-2000, Nairobi 9-12 May 05 -RP



General Framework for migrating Telephony networks towards Next Generation Networks (NGN)

In markets with a high growth in traditional voice services (which is the case for most developing countries), substantial extensions will be required to the existing telephony network in order to cover the huge need for new lines. Established Service Providers will have to decide on how to extend their networks: using more traditional circuit-switched solutions or implementing a distributed network architecture, with a common, packet-based transport layer for voice and data.

ITU-BDT Regional Seminar for Africa on Fixed Mobile Convergence and Guidelines on the smooth transition of existing mobile network to IMT-2000, Nairobi 9-12 May 05 -RP



General Framework for migration to NGN (The Essential Report on IP telephony – ITU-D)

For this to occur many aspects like network consolidation, expansion and migration need to be taken into account in a way that is specific for each operator. However one can devise the following generic step-wise approach. Such steps are generic in the sense that they are not mandatory for each specific operator case. Still, they offer interest by highlighting major evolutionary steps of networks that might occur in the following years.

- Step 1: use of today's TDM based network for voice telephony and Internet access
- Step 2: consolidation of switching and access equipment;
- Step 3: introduction of Voice-over-Packet technology for trunking;
- Step 4: introduction of Voice-over-Packet technology in access and CPE
- Step 5: multimedia services and new applications;
- Step 6: end-of-life replacement of legacy infrastructure and migration to all-IP signalling.

ITU-BDT Regional Seminar for Africa on Fixed Mobile Convergence and Guidelines on the smooth transition of existing mobile network to IMT-2000, Nairobi 9-12 May 05 -RP

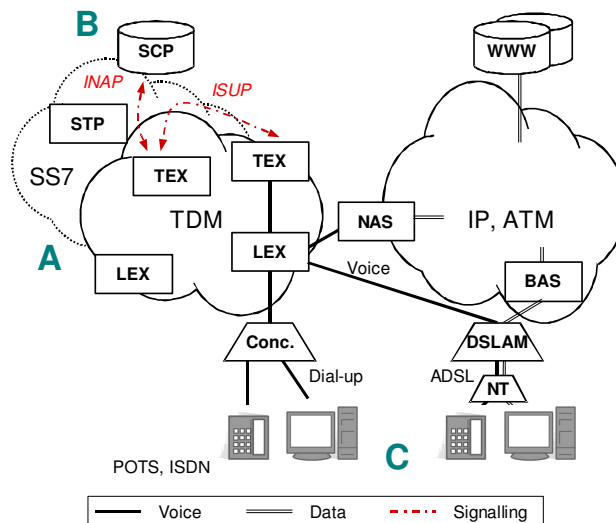

Step 1: PSTN for Voice and Internet

ITU-BDT Regional Seminar for Africa on Fixed Mobile Convergence and Guidelines on the smooth transition of existing mobile network to IMT-2000, Nairobi 9-12 May 05 -RP

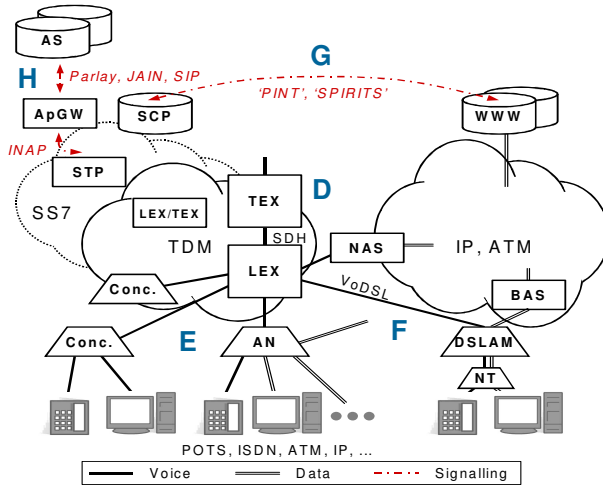

Step 2 : PSTN Consolidation

ITU-BDT Regional Seminar for Africa on Fixed Mobile Convergence and Guidelines on the smooth transition of existing mobile network to IMT-2000, Nairobi 9-12 May 05 -RP

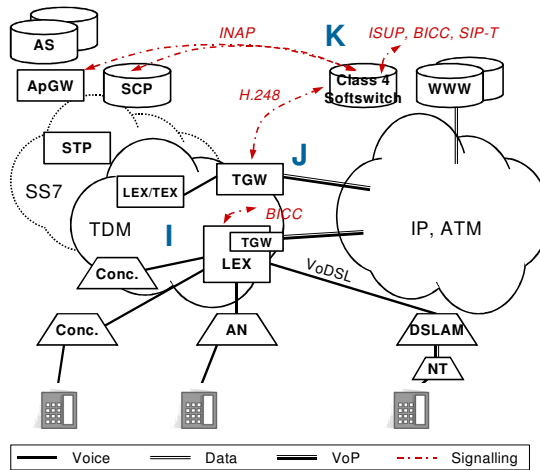

Step 3: Voice over Packet for Trunking

ITU-BDT Regional Seminar for Africa on Fixed Mobile Convergence and Guidelines on the smooth transition of existing mobile network to IMT-2000, Nairobi 9-12 May 05 -RP

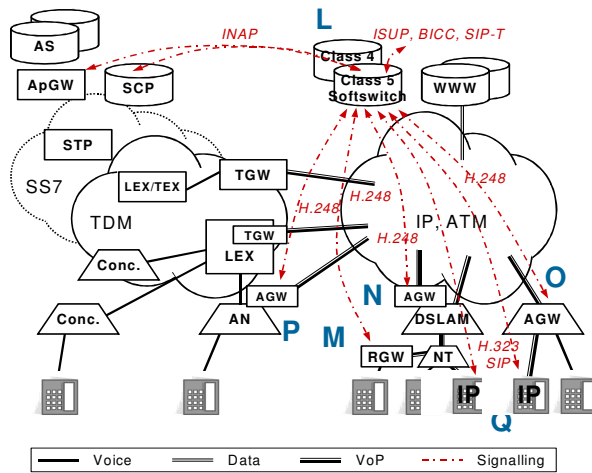

Step 4: Voice over Packets in access and CPE

ITU-BDT Regional Seminar for Africa on Fixed Mobile Convergence and Guidelines on the smooth transition of existing mobile network to IMT-2000, Nairobi 9-12 May 05 -RP

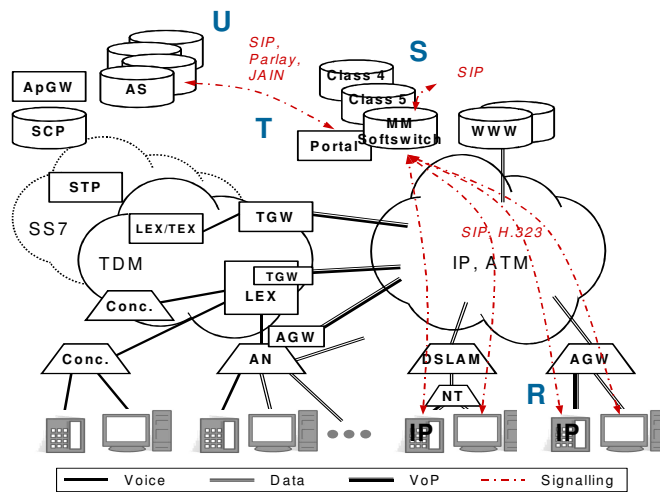

Step 5 : Multimedia

ITU-BDT Regional Seminar for Africa on Fixed Mobile Convergence and Guidelines on the smooth transition of existing mobile network to IMT-2000, Nairobi 9-12 May 05 -RP

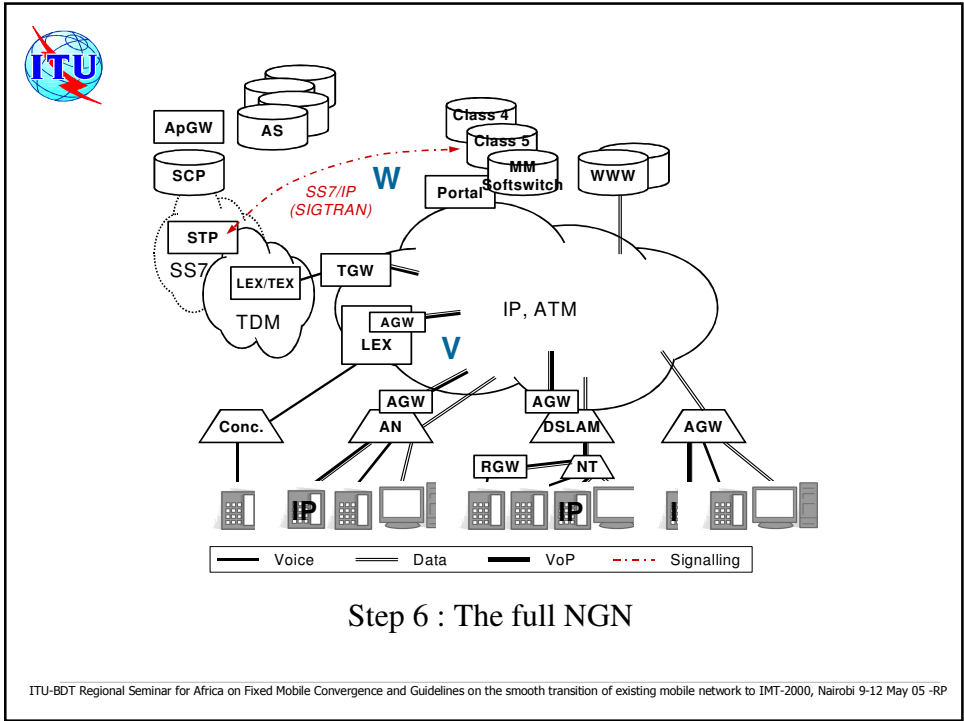

ANNEX: Abbreviations

ADPCM	Adaptive Differential Pulse Code Modulation	NGN	Next Generation Network
ADM	Adaptive Delta Modulation	NT	Network Termination
ADSL	Asymmetric Digital Subscriber Line	OPEX	Operational Expenditure
AGW	Access Gateway	OSA	Open Service Access
AN	Access Node	OSI	Open System Interconnection
API	Application Programming Interface	PABX	Private Automatic Branch Exchange
ATM	Asynchronous Transfer Mode	PC	Personal Computer
BAS	Broadband Access Server	PCM	Pulse Code Modulation
BICC	Bearer Independent Call Control	PDA	Personal Digital Assistant
CAPEX	Capital Expenditure	PKI	Public Key Infrastructure
CPE	Customer Premises Equipment	POTS	Plain Old Telephony Service
CME	Circuit Multiplication Equipment	PSTN	Public Switched Telephone Network
DPCM	Differential Pulse Code Modulation	QoS	Quality of Service
DNS	Domain Name System	RGW	Residential Gateway
DSL	Digital Subscriber Line	RTCP	Real-time Transmission Control Protocol
DSLAM	Digital Subscriber Line Access Multiplexer	SCP	Signaling Control Point
DFFSERV	Differentiated Services	SCCP	Signaling Connection Control Part
FTP	File Transfer Protocol	SCN	Switched Circuits Network
HTTP	Hyper Text Transfer Protocol	SCTP	Signaling Connection Transfer Protocol
IETF	Internet Engineering Task Force	SIGTRAN	Signalling Transfer Working Group (IETF)
INAP	Intelligent Network Application Part	SIP	Session Initiation Protocol
INTSERV	Integrated Services	SLA	Service Level Agreement
IP	Internetworking Protocol	SLS	Service Level Specification
IPDN	IP Telephony Network	SS7	Signaling System N°7
ISP	Internet Service Provider	STP	Signaling Transfer Point
ISUP	ISDN User Part	TEX	Transit Exchange
ITSP	Internet Telephony Service Provider	TCAP	Transaction Capabilities Application Part
JAIN	Java API for Integrated Networks	TCP	Transmission Control Protocol
LAN	Local Area Network	TDM	Time Division Multiplexing
LEX	Local Exchange	TGW	Trunking Gateway
LMDS	Local Multipoint Distribution System	TLS	Transmission Level Security
MEGACO	Media Gateway Control (IETF Workgroup)	UDP	User Datagram Protocol
MGCP	Media Gateway Control Protocol	URI	Universal Resource Identification
MOS	Mean Opinion Score	VoDSL	Voice over Digital Subscriber Line
MPEG	Motion Picture Expert Group	VoIP	Voice over IP
NAS	Network Access Server	VPN	Virtual Private Network
NAT	Network Address Translation	WAN	Wide Area Network

ITU-BDT Regional Seminar for Africa on Fixed Mobile Convergence and Guidelines on the smooth transition of existing mobile network to IMT-2000, Nairobi 9-12 May 05 -RP



TERMS AND DEFINITIONS

Telephone Number Mapping (ENUM): Protocols for mapping telephone numbers to IP phone identifiers (i.e. E.164 numbers to URIs).

IP Network: An IP network is a network that uses IP technologies to transport information. It may be a Private IP network, or a Carrier's network.

Phone: Phone refers to a PSTN terminal.

IP Phone: IP phone refers to a terminal (e.g. dedicated voice terminal or multipurpose personal computer) that is connected directly (e.g. Through an Ethernet interface or an xDSL line) to an IP network.

IP telephony: "IP telephony" is a service that enables the exchange of voice information, primarily in the form of packets, using IP protocols.

Internet Telephony: The combination of the term 'Internet' with the term 'telephony' is regarded as a specific use of the Internet, rather than a service. The Internet offers many capabilities to users, including the ability to carry bi-directional speech in real time or near real time. This is considered to be an Intrinsic capability of the Internet and not a telecommunications service.

(Note) Internet telephony is a particular application of the Internet and therefore falls outside of the scope of this document.