



ITU / BDT Regional Network Planning Workshop with Tool Case Studies for the Arab Region

Cairo - Egypt, 16– 27 July 2006

Network Architectures for Planning and Technological alternatives. NGN: What and How

Oscar González Soto
ITU Consultant Expert
Strategic Planning and Assessment



Network Architectures and NGN Content

- **Modeling of the network by layers and segments for planning purposes**
- **Technology solutions for Access and Core architectures**
- **NGN: What and how**



Network Architectures and NGN Network Modeling

- **High complexity of the whole Network requires a modeling and splitting in subnetworks to facilitate analysis and design.**
 - **By Layers** in a vertical dimension following the client-server relation (one layer is supported in the layer below and provides resources for the layer up). **Physical, Transmission, Switching, etc.**
 - **By Segments** or splitting of the end to end communication into subareas as **customer premises, access, core national, core international**
 - **By Technologies** or underlying technique as **PDH, SDH, PSTN, ATM, IP, NGN, GSM, 3G, WiMAX, etc.....**
- **Network Planning follows the same splitting or partitioning to allow treatment of the problems and adaptation to associated**



Network Architectures and NGN Topologies

- **Meshed (direct connection among nodes)**
 - Fully (for all network nodes)
 - Partial (with limited connectivity)
- **Ring**
 - Single, Multiple, Folded
- **Star**
- **Tree**
- **Linear**
- **Combined**

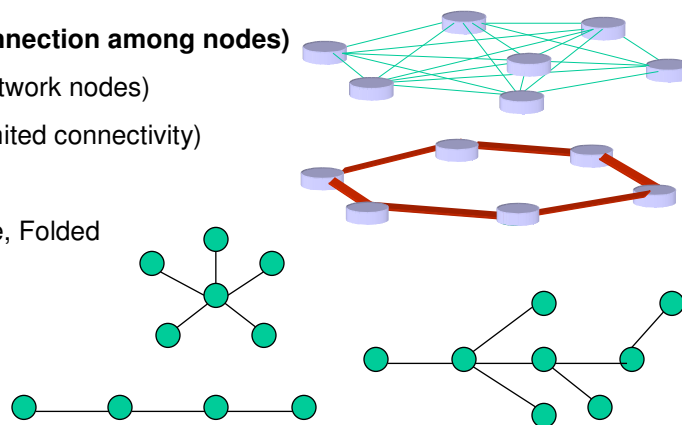



Network Architectures and NGN Access Network: Wireline

Typical Access Network structure: (classical)

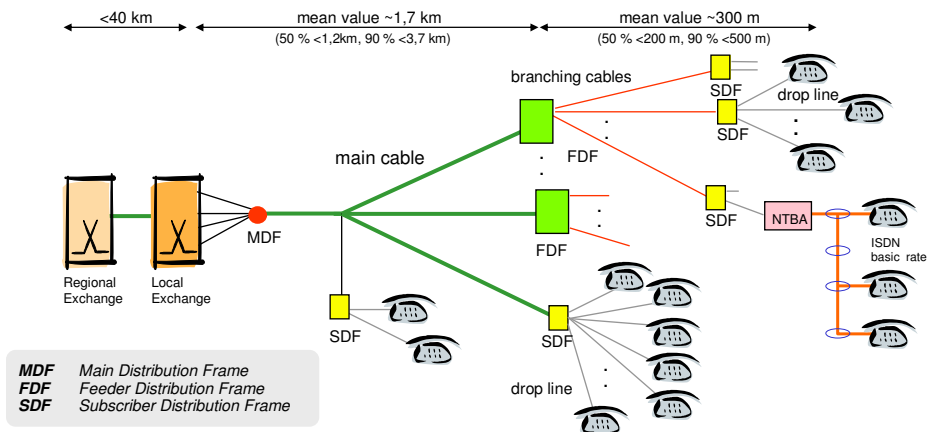

July 2006

ITU/BDT Network Architectures and NGN - O.G.S.

slide 5



Network Architectures and NGN Access Network: Wireline Evolution: FTTx

Typical Access Network evolution towards BB and Convergence

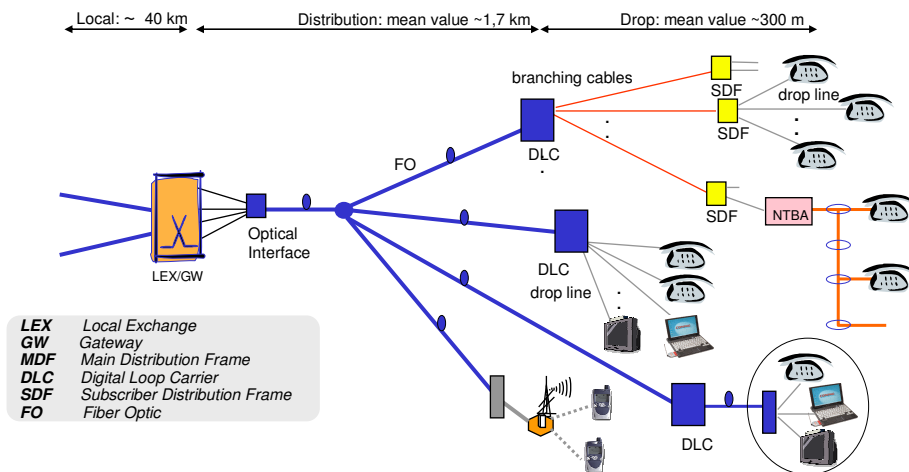

July 2006

ITU/BDT Network Architectures and NGN - O.G.S.

slide 6



Network Architectures and NGN Access Network: x.WIP

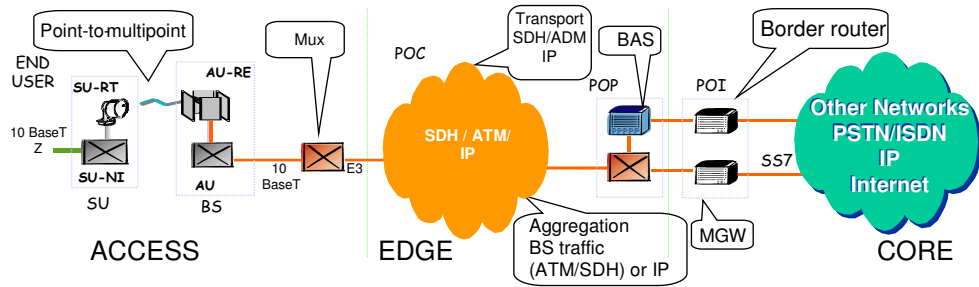

SU: Subscriber Unit
SU-RT: Subscriber Unit Outdoor Unit
SU-NI: Subscriber Unit Indoor Unit

BS: Base Station
AU: Access Unit
AU-RE: Radio Front-end
MGW: Media Gateway

POC: Point of Concentration
POP: Point of presence
POI: Point of Interconnection
BAS: Broadband Access Server

Note: The current Network description shows the ATM approach (BAS is needed). A fully IP scenario is also feasible (BAS is not needed)

July 2006

ITU/BDT Network Architectures and NGN - O.G.S.

slide 7



Network Architectures and NGN Access Network: HFC

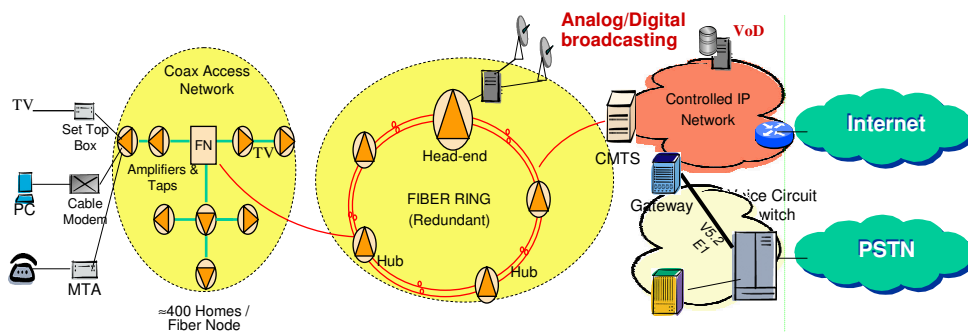

MTA: Multimedia Terminal Adapter
FN: Fiber Node
CMTS: Cable Modem Termination System
VoD: Video on Demand
IN: Intelligent Network

July 2006

ITU/BDT Network Architectures and NGN - O.G.S.

slide 8



Network Architectures and NGN Access Network: xDSL

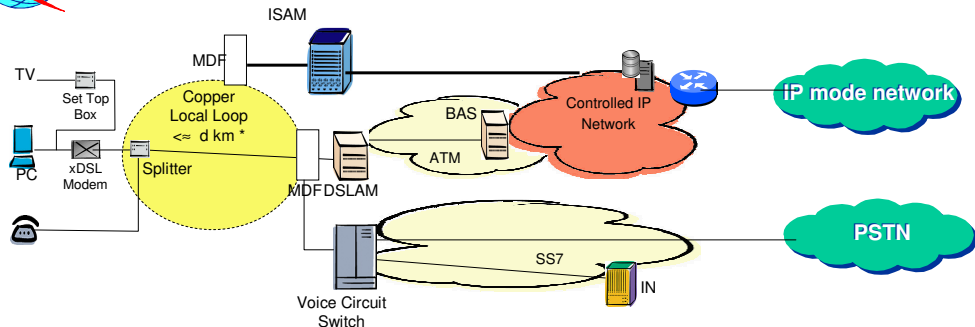

* Bandwidth/distances per solution

ADSL: up to 4/8 Mbps/800 kbps $d \leq 3/1,5$ km

ADSL plus: up to 4/8 Mbps/800 kbps $d \leq 4.5/2,1$ km

SHDSL: up to 2.3 Mbps symmetric $d \leq 1.8$ km

VDSL: up to 52 Mbps Assym/ 26 Mbps Sym $d \leq 300$ m

(In all cases, higher distances imply less bitrate following bandwidth shape curve)

MDF: Main Distribution Frame

DSLAM: Digital Subscriber Line Access Multiplexer

IN: Intelligent Network

BAS: Broadband Access Server

July 2006

ITU/BDT Network Architectures and NGN - O.G.S.

slide 9



Network Architectures and NGN Access Network : Multiservice Nodes

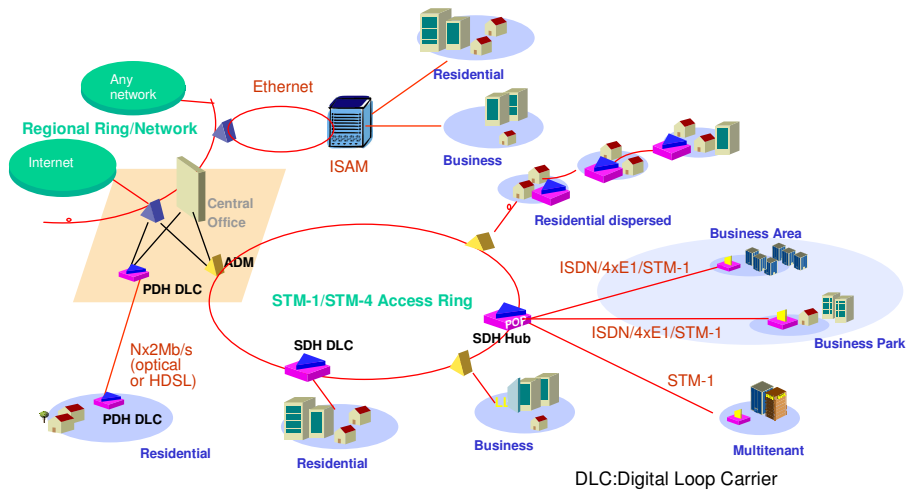

July 2006

ITU/BDT Network Architectures and NGN - O.G.S.

slide 10



Network Architectures and NGN Access Network : FTTU

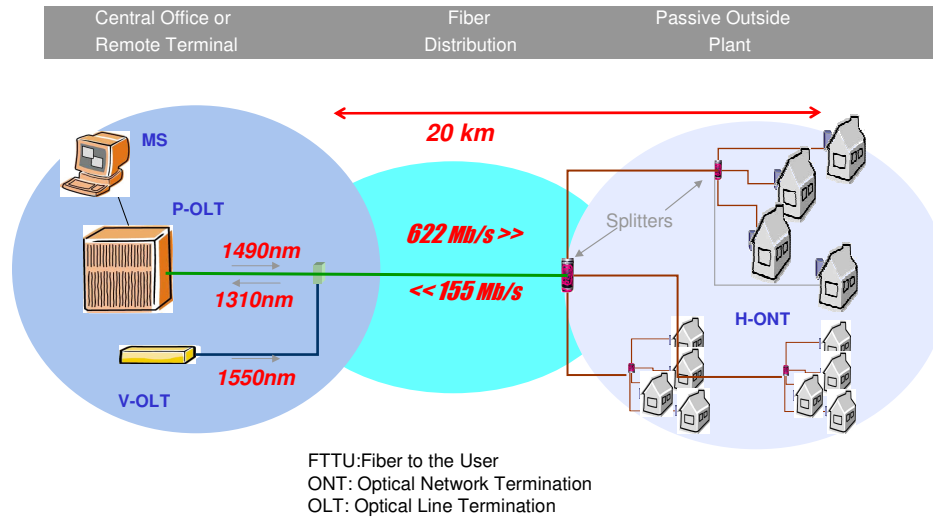

July 2006

ITU/BDT Network Architectures and NGN - O.G.S.

slide 11



Network Architectures and NGN: Technological alternatives at core

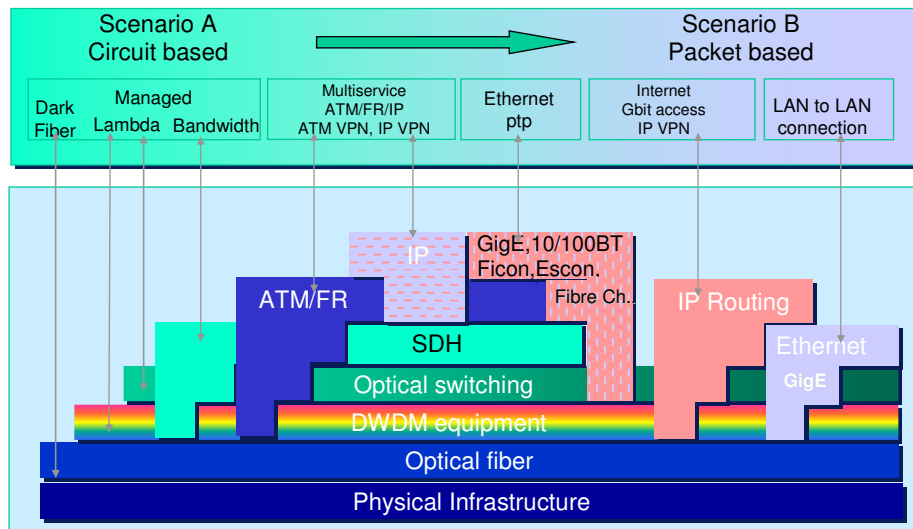

July 2006

ITU/BDT Network Architectures and NGN - O.G.S.

slide 12



Network Architectures and NGN Multi-Layering in Transport: Introduction of WDM

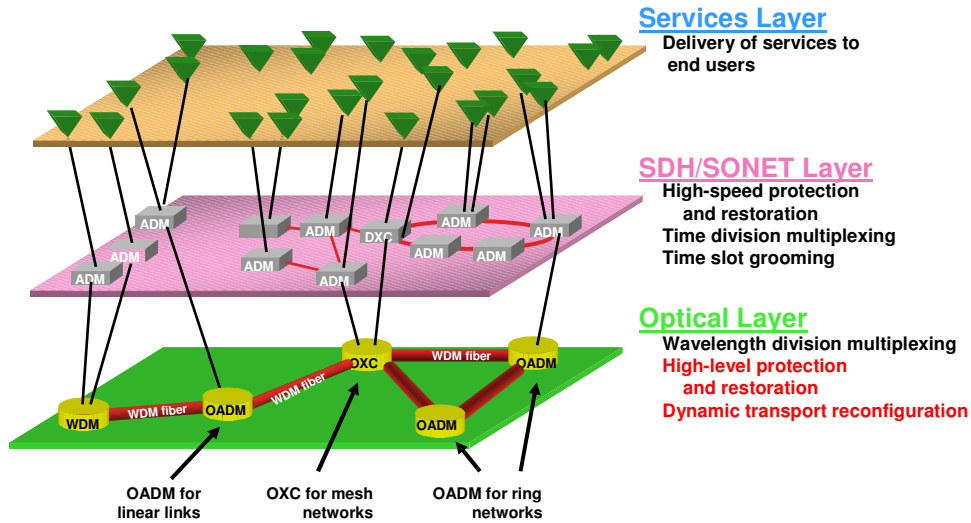

July 2006

ITU/BDT Network Architectures and NGN - O.G.S.

slide 13



Network Architectures and NGN: Evolution towards NGN

NGN concept

- A **multi-service network** able to support voice, data and video
- A network with a control plane (signaling, control) **separated** from the transport/switching plane
- A network with **open interfaces** between transport, control and applications
- A network using **packet technology** (IP) to transport of all kind of information
- A network with **guaranteed QoS** for different traffic types and SLAs

July 2006

ITU/BDT Network Architectures and NGN - O.G.S.

slide 14



Network Architectures and NGN: Evolution towards NGN

NGN layers

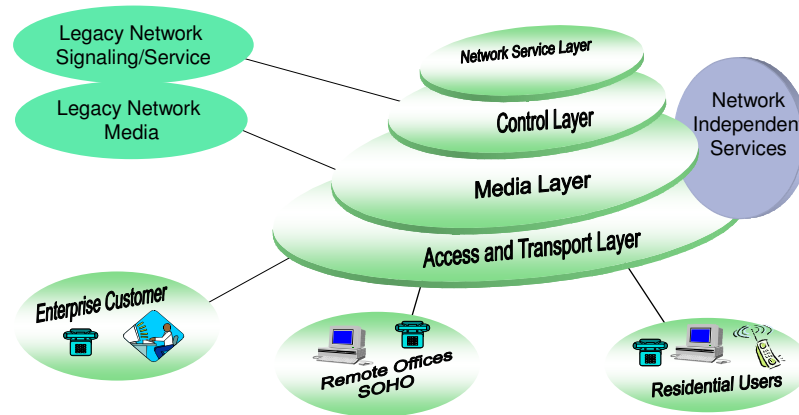

Network Architectures and NGN: Evolution towards NGN

NGN : Why

- **Flexibility** for service building and offering
- Expectation of **cost reductions** by sharing infrastructure and systems
- **Simplification of O&M**, thus lowering OPEX.
- Use of **open interfaces** leads for:
 - quick deployment of services and applications
 - new services (third parties)



Network Architectures and NGN Modeling issues for NGN and 3G

- New **models** to represent **multiservice flows**
- New **dimensioning methods** for resources handling multimedia services with QoS
- New **measurement procedures** for aggregated multiservice traffics
- New **multicriteria dimensioning** for 3G and xG combining coverage by frequency, service speed and data traffic capacity
- Which procedures to ensure **interoperability** and end-to-end performance across multiple domains?
- Which units to define dimensioning and costing units for **interconnection**?



Network Architectures and NGN QoS and Performance Issues

- Quality of Service (QoS) domains to be modeled, defined and/or extended for NGN and 3G. Measured in waiting time and/or loss probabilities
- Domains for QoS evaluation:
 - **Service accessibility**: capability to access a service
 - **Connection establishment**: Capability to get connection
 - **Information transfer**: Quality of information delivery
 - **Reliability**: Failure probability
 - **Availability**: Probability of system being active
 - **Survivability**: Capability to provide service in abnormal conditions
 - **Security**: Information and systems protection level
 - **Qualitative**: Intelligibility, audibility, visualization ... of information content as derived from user perception (MOS)



Network Architectures and NGN Traffic flow types for QoS based dimensioning

- **T1) QoS constant stream**: bandwidth transmission at a constant speed with a specified delivery and jitter (ie: video distribution)
- **T2) QoS variable stream** : bandwidth transmission at a variable speed derived from a user information and coding algorithm which requires guaranteed quality and specified jitter (ie: VoIP, Video streaming, audio streaming, etc.)
- **T3) QoS elastic**: bandwidth transmission at a variable speed without jitter restrictions and asynchronous delivery (ie: browsing, file transfer, mail, UMS, etc.)



Network Architectures and NGN Traffic units for aggregated flows

Proposal of NGN units in multiservice networks/interfaces for demand/dimensioning/costing :

- Equivalent Sustained Bit Rate (ESBR) or aggregated equivalent rates for same QoS category flows efficiently carried in a common reference busy period (ie. 5 minutes)
- Computed as weighted average for the services at QoS category (i) and customer classes (j) at each network element:
$$\sum_i \sum_j \text{ESBR}_{ij}$$



Network Architecture and NGN Existing networks and architecture

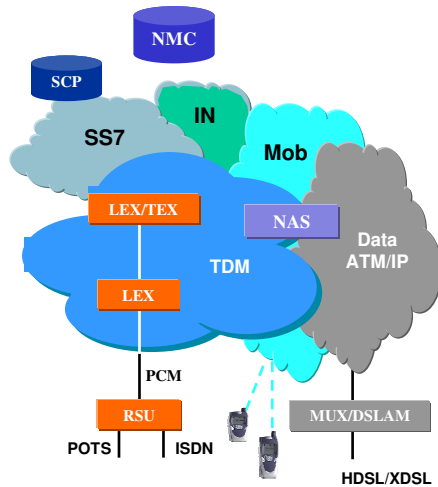

- 5 different network types to handle telecom services
- TDM for fixed and mobile networks working in circuit mode with end to end reserved paths
- SS7 and IN network working with message switching mode
- Data network working with leased lines and packet mode with different and conventional IP protocols

July 2006

ITU/BDT Network Architectures and NGN - O.G.S.

slide 21



Network Architecture and NGN Existing networks and architecture

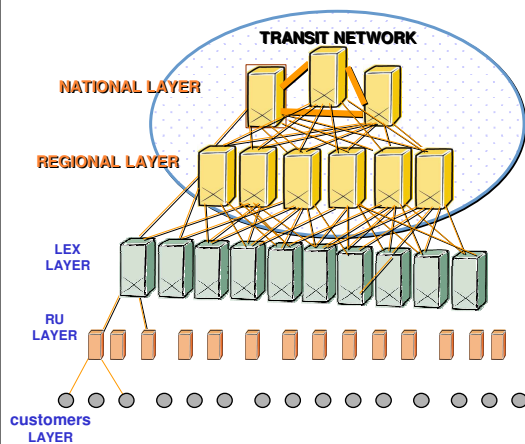

- Hierarchical topology with 4 to 5 layers, connectivity to the upper next layer and within each layer as a function of economical optimization
- Number of nodes as a function of O/D traffic and nodes capacity
- Service handling for media, signaling and control at all exchange nodes
- Carrier grade quality with well defined QoS criteria and standardized engineering rules

July 2006

ITU/BDT Network Architectures and NGN - O.G.S.

slide 22



Network Architecture and NGN Architecture migration: Topology

What changes from current scenario towards target network ?

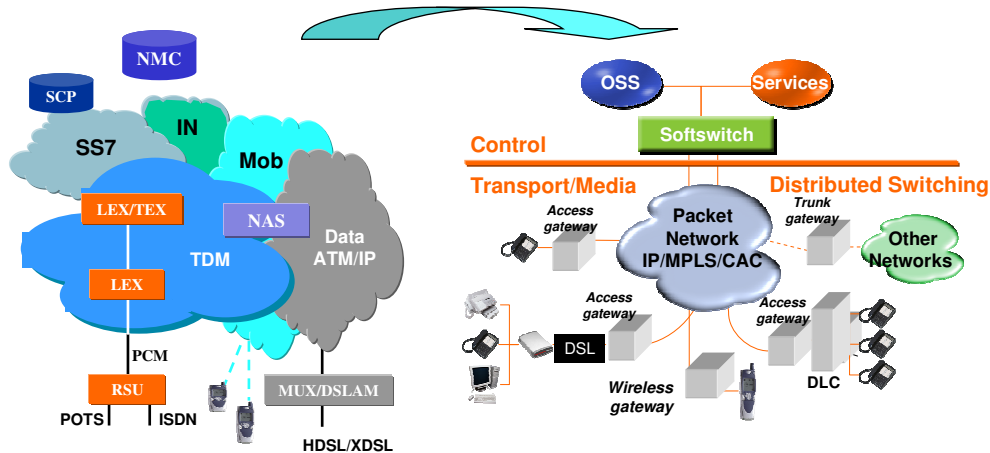

July 2006

ITU/BDT Network Architectures and NGN - O.G.S.

slide 23



Network Architectures and NGN Unified IMS/TISPAN Model for Mobile and Fixed

What is IMS?

- **Concept:**
 - Application of 3GPP's IMS architecture and protocol extensions for fixed networks
- **Key actors:**
 - Operators
 - ETSI, TISPAN, VASA, ITU-T
 - Equipment vendors
- **Timeline:**
 - ETSI NGN Globalisation Group, with launch mid 2004

Why IMS ?

- Rational for mobile networks
- Deliver person-to-person real-time IP-based multimedia communications
 - Person-to-person, person-to-machine
- Fully integrate real-time with non-real-time multimedia communications.
 - i.e., live streaming and chat
- Enable different services and applications to interact
- Easy user setup of multiple services in a single session, or multiple synchronized sessions
- Operators have better control of service value chain
 - End-to-end QoS

July 2006

ITU/BDT Network Architectures and NGN - O.G.S.

slide 24



Network Architectures and NGN Simplified IMS/TISPAN Architecture

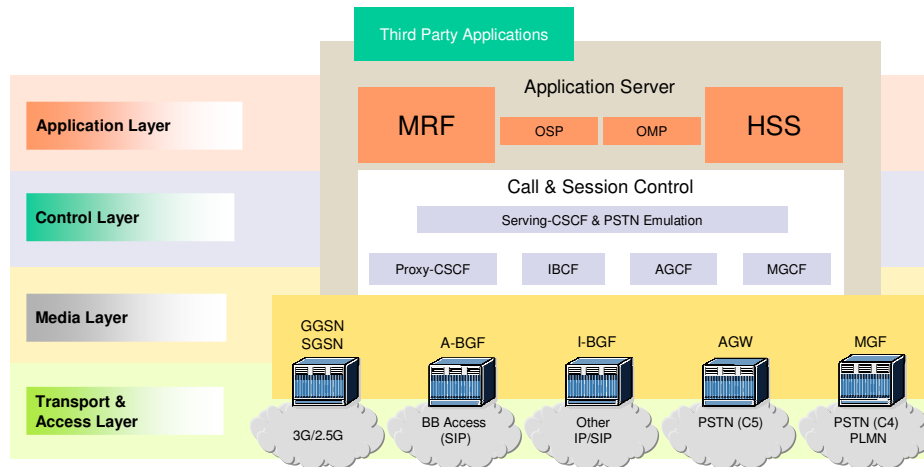

July 2006

ITU/BDT Network Architectures and NGN - O.G.S.

slide 25



Network Architectures and NGN Evolution towards NGN

Current end to end architecture

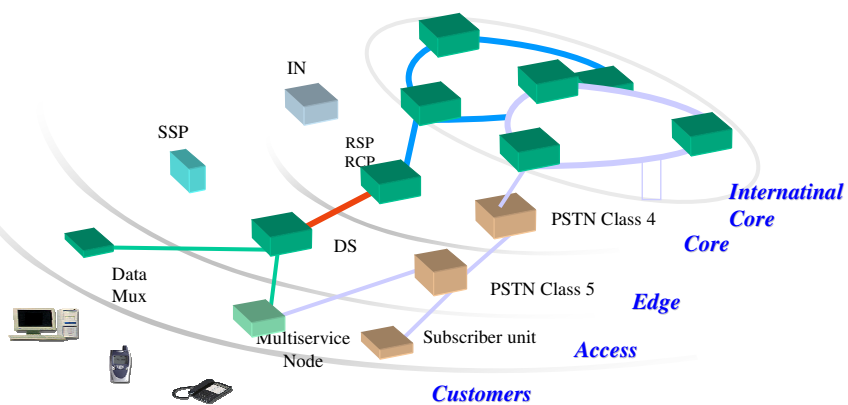

July 2006

ITU/BDT Network Architectures and NGN - O.G.S.

slide 26



Network Architectures and NGN: Evolution towards NGN

Target end to end architecture for NGN

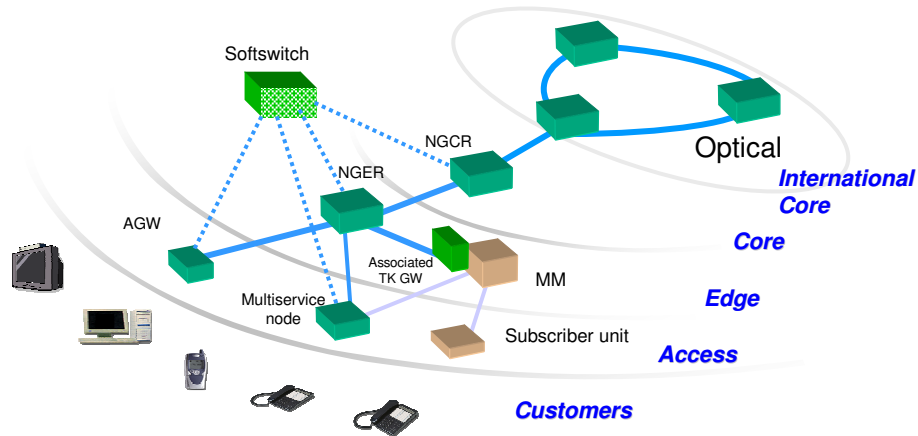

July 2006

ITU/BDT Network Architectures and NGN - O.G.S.

slide 27



Network Architecture towards NGN Architecture Evolution: Topology

Topological changes impact on infrastructure and are slower to implement than technology substitution

- **Less network nodes and links** due to the higher capacity of systems (one order of magnitude).
- **Same capillarity** at access level due to identical customer location
- Topological **connectivity higher** for high capacity nodes and paths for security
- **High protection** level and diversity paths/sources in all high capacity systems, both at functional and physical levels

July 2006

ITU/BDT Network Architectures and NGN - O.G.S.

slide 28



Network Architectures and NGN: Cost drivers and trends

- Network **physical infrastructure** as a function of location and density (costs proportion around 70% in the access segment)
- **Volume** of customers per category
- **Bandwidth** demand per origin/destination
- Packet **processing rates** for control related functions
- **Variety** of applications/services and related platforms
- Content **storage** and location within the network
- **Leasing** of physical or communication resources

Fundamental importance of economies of scale by volume and convergence at network resources, service platforms and OSS



Network Architectures and NGN: Cost drivers and trends

Cost trends for NGN

- Cost reduction in CAPEX due to technological economy of scale by larger capacities
- Similar values for costs in the physical civil infrastructure
- OPEX in NGN trends to be lower due to the integrated operation and maintenance
- Plan higher investments in security/survivability with diversity paths and protection for large capacity systems

Check and validate correct cost modelling with fixed and variable components as a function of economy of scale



Network Architectures and NGN Summary Remarks

- **Multiservice flows** impose a set of requirements on models and tools for NGN and 3G.
- **Interoperability and interconnection** require special effort to players and planners to ensure end-to-end performance
- High number of new technologies and capabilities reinforce the need of **solution mapping** for each country scenario
- Complexity of converged networks require the use of **high quality support tools**