



**AFRICAN
CDMA FORUM**

Online CDMA Technology Resource &
Discussion Forum

CONVERGENCE

Will
Convergence be
a Tool for Social
Change in
Africa?



- My talk is called “Convergence with Advanced Wireless Systems” in Africa?”
- I hope to inform the audience what has been happening worldwide and specifically in Africa. What may make commercial sense and the implications for regulators and policy makers throughout Africa.
- What Africa wants and needs regarding spectrum allocation for the economies of scale that convergence may drive.
- Secondly, not to overtax these converged networks with high licence fees, airtime taxes and especially handset import taxes.

AGENDA

1. List technologies to converge
2. Contents to converge
3. How does Africa benefit
4. Status of telephony in Africa
5. Wireless technologies in Africa
6. The African CDMA Forum
7. What Africa wants and needs



**AFRICAN
CDMA FORUM**

Online CDMA Technology Resource &
Discussion Forum

A place where you can find all the information regarding CDMA hardware, software, find qualified staff, jobs, solutions to problems, purchase certified handsets at best prices, hold discussions with other operators, see where conferences are being held, assist your regulator to find out best practices in other countries and much, much more.....

African CDMA Forum

Bill Hearmon

www.3gafrica.org

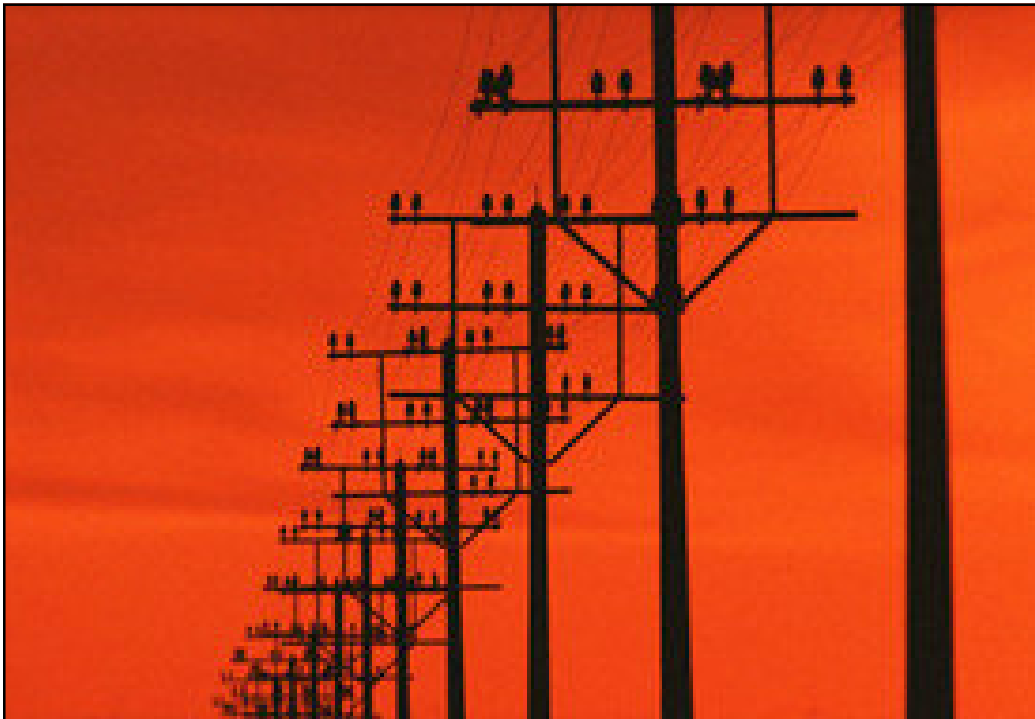



Why Converge?

- It is economically driven?
- Examples from transport industries
- Will an operator increase ARPU?

Futuristics

- What should the information, communications technology and media material landscape look like in thirty years time.
- A number for all for life?

Other industries in the past?

- Automobiles
- Transport
- Medicine
- Housing
- Manufacturing
- Shipping
- Railroads
- Agriculture
- Fishing
- Animal husbandry

Wireless Air Interfaces

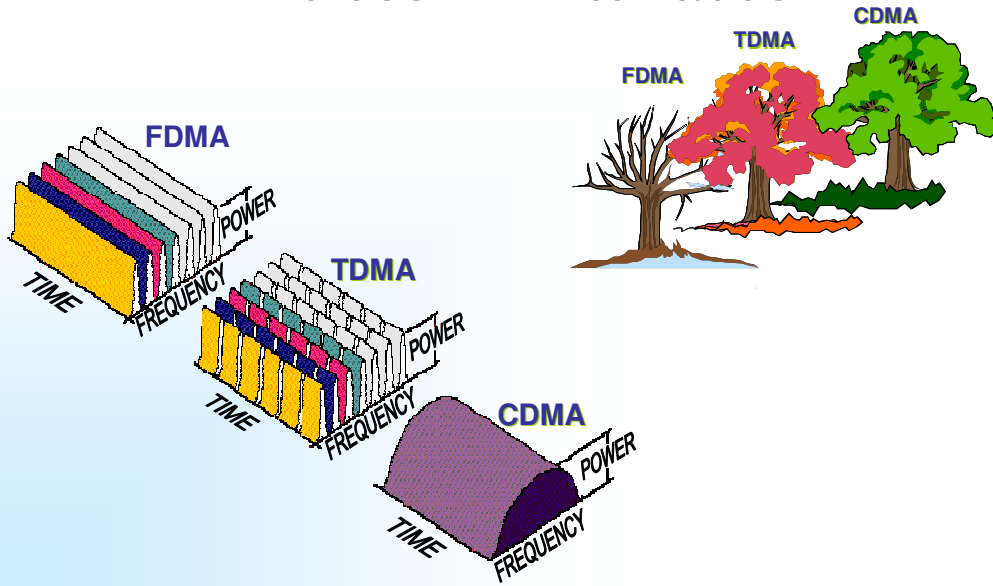

CDMA= 3G Spectrum Allocations

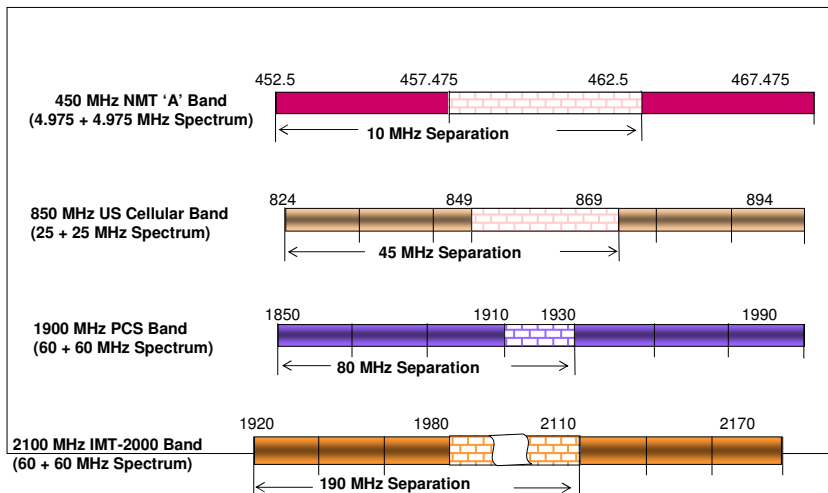

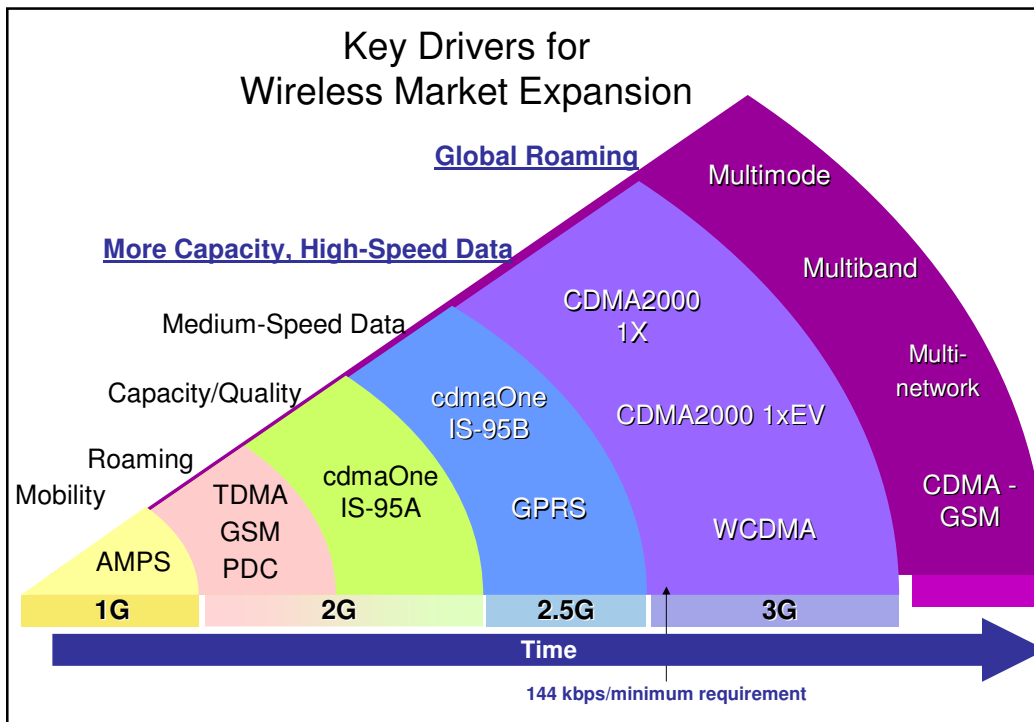

Unified Licensing effects

- The cases in Nigeria, India, Afghanistan and Morocco
- Works in progress in Africa
- The regulators point of view
- Is there a “Best Practice?”

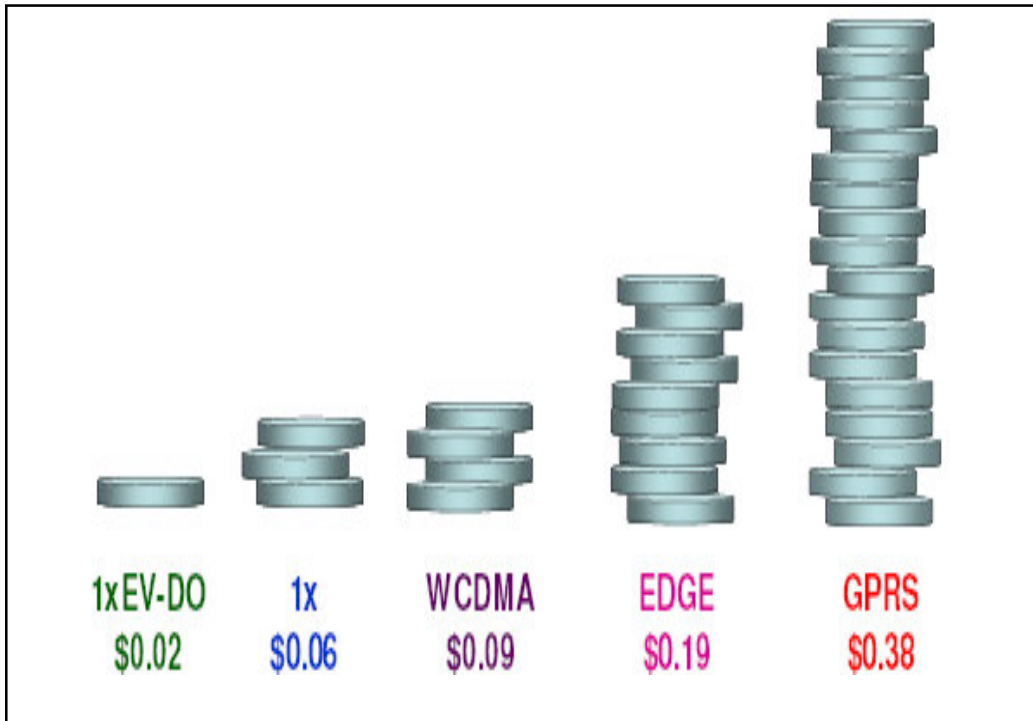

African Markets Addressed with CDMA

Best practices analysis of CDMA work around the world

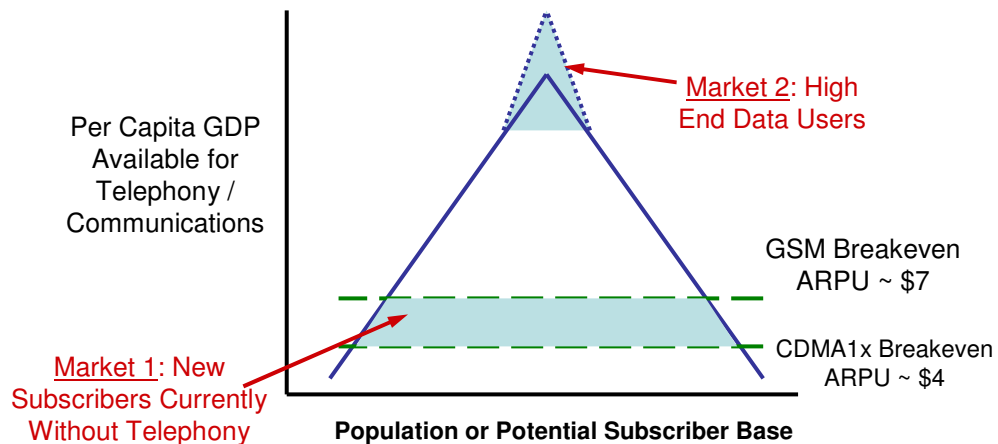

CDMA Potential in Africa: Low-Cost Telephony, and Data Services in 800 and 450MHz Frequency Bands

CDMA Benefits

- Fastest growing air interface technology in the world
- High quality voice and data transmissions
- Most spectrally efficient air interface
- Provides excellent coverage (multipath diversity)
- Handoffs are done in a robust manner
- Offers secure transmissions
- Offers lowest cost per minute, megabyte or message
- Consumes less battery power
- Supports new High Data Rate technologies



**CDMA is
a Superior
Air Interface
Technology**



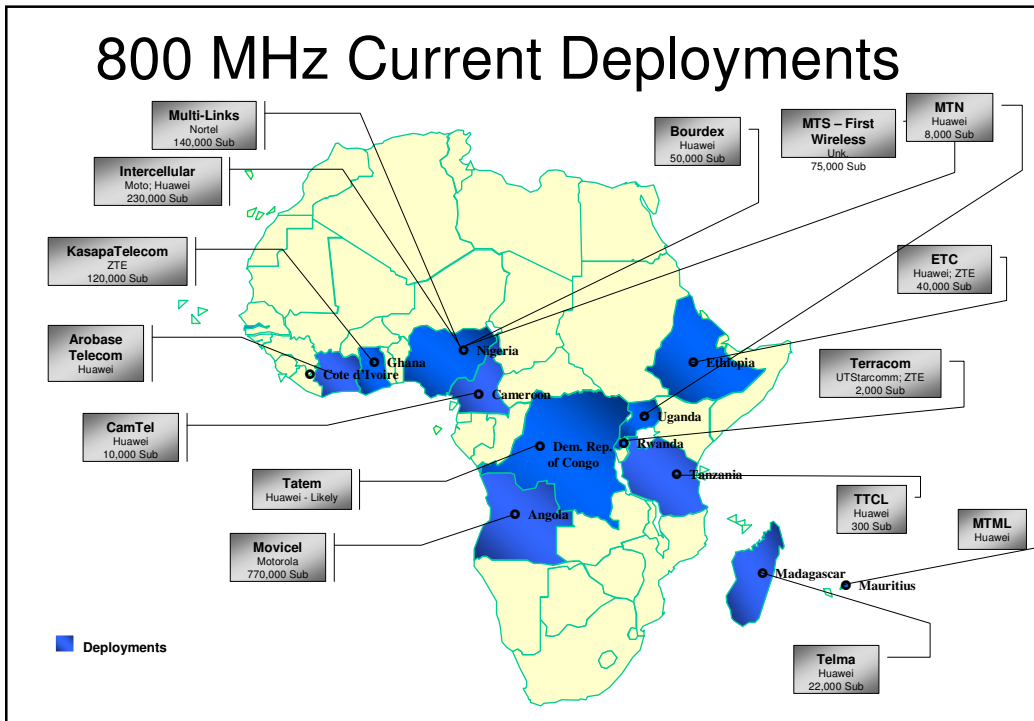
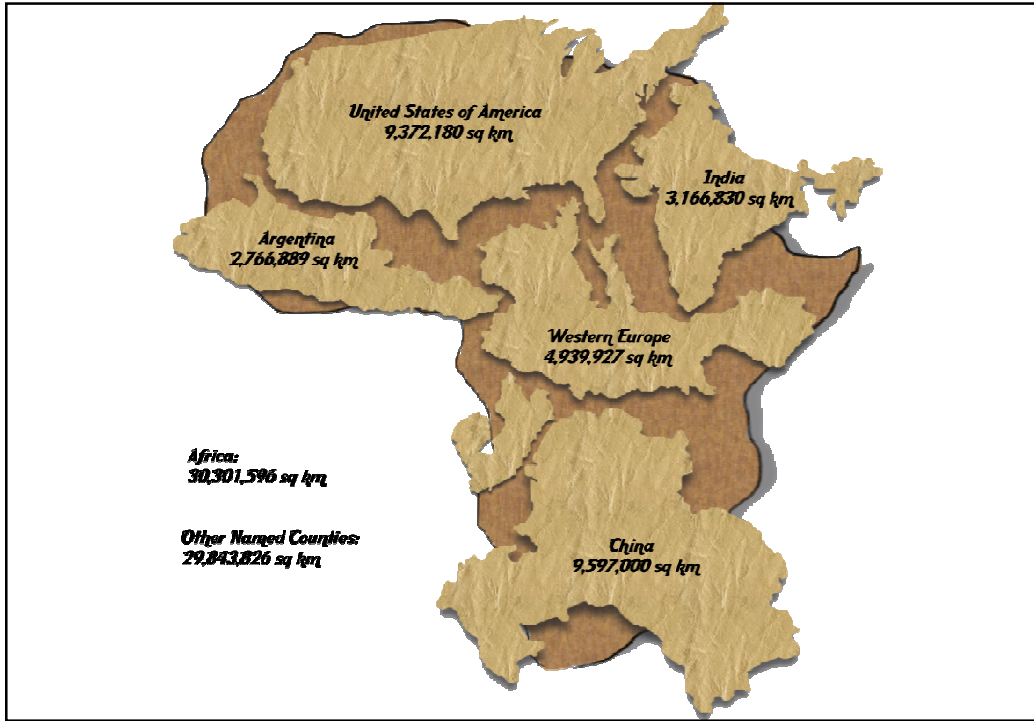

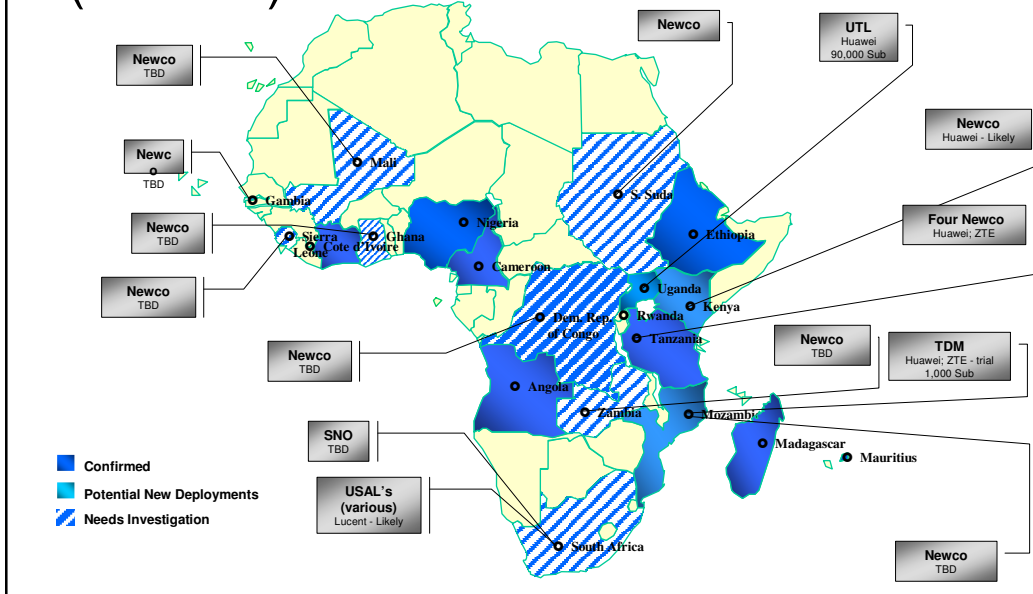

Projected 800 MHz Deployments (Dec'06)

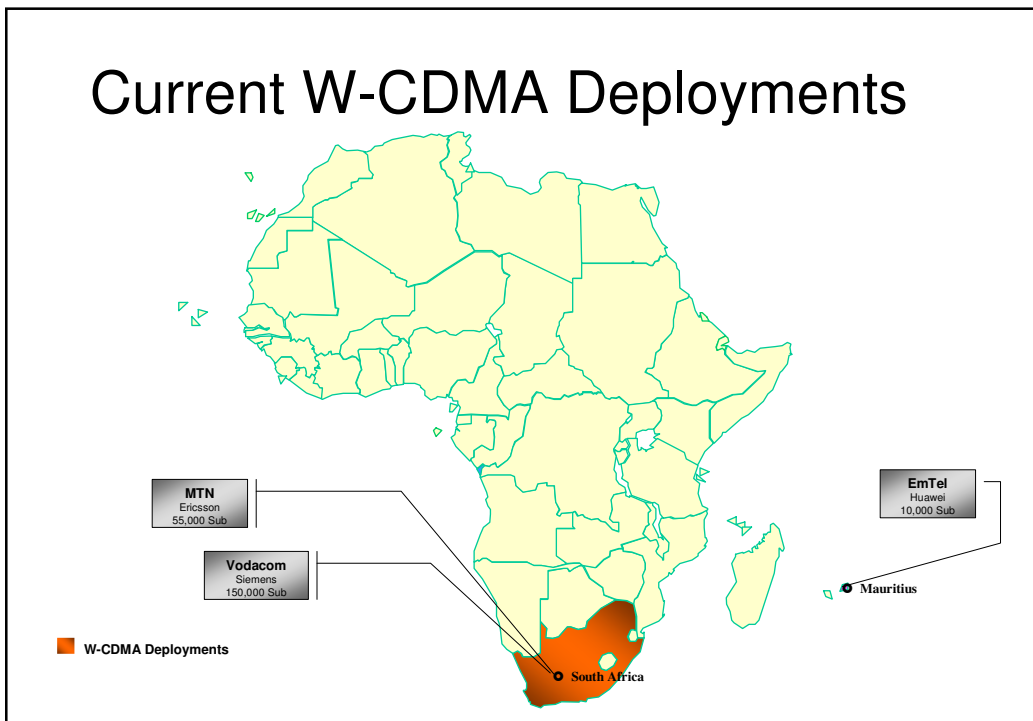

Current W-CDMA Deployments







AFRICAN CDMA FORUM

Online CDMA Technology Resource & Discussion Forum

A place where you can find & share information regarding CDMA operators, hardware, software & Hot Jobs in CDMA all over Africa

> OPERATOR
> TECHNOLOGY
> TRAINING
> FORUM





WELCOME TO AFRICAN CDMA FORUM
ONLINE CDMA TECHNOLOGY RESOURCE & DISCUSSION FORUM
 The main objective of the African CDMA Forum is to share business and technology information and resources between and by CDMA operators, broadcasters, manufacturers, software companies, government, academia and the users in Africa.

We aspire to provide, through African CDMA Forum, a platform to people to openly address their queries and provide a resource and database that shall provide them accurate and reliable information about the latest practices, news and developments in CDMA business and technology.

We hope you shall benefit from the wealth of information provided by the African CDMA Forum and its partner organizations whose information is provided on this web site.

PARTNERS









NEWS & EVENTS

- ▶ Power shortages a headache for cellcos
[11, April, 2006]
- ▶ Smart improves 3G coverage, claims nationwide service
[07, April, 2006]
- ▶ WIMAX trial success
[06, April, 2006]
- ▶ Telkom plans ZAR30bn investment
[06, April, 2006]
- ▶ Ukraines CDMA WILL subscribers up to 135,000
[05, April, 2006]
- ▶ Dubai telecom stock sale triggers investors' ru
[22, March, 2006]
- ▶ 3G introduction in SA could soon reduce phone bills
[18, March, 2006]
- ▶ China Mobile profit rockets 28 per cent
[16, March, 2006]
- ▶ Strong 3G growth in Japan
[15, March, 2006]
- ▶ MTN South Africa set to Launch HSDPA 3G Mobile Access
[10, March, 2006]

MEMBER'S AREA

Username

Password

[Get Registered](#)

MORE LINKS

- ▶ TCRA Spectrum
- ▶ CDMA Applications & Services
- ▶ Resume Posting
- ▶ CDMA Operators Subscribers Forecast & Tariff
- ▶ CDMA Technology Terminology Guide
- ▶ White Papers
- ▶ FAQ's



Country







AFRICAN CDMA FORUM

Online CDMA Technology Resource & Discussion Forum

A place where you can find & share information regarding CDMA operators, hardware, software & Hot Jobs in CDMA all over Africa

> OPERATOR
> TECHNOLOGY
> TRAINING
> FORUM

CDMA OPERATORS

CDMA DEPLOYMENTS WITHIN SUB-SAHARAN AFRICA



MORE LINKS

- ▶ CDMA Deployment Map
- ▶ 450 MHz Current Deployment
- ▶ Prospective 450 MHz (Dec 06)
- ▶ 800 MHz Current Deployment
- ▶ Prospective 800 MHz (Dec 06)
- ▶ 1900 MHz Current Deployment
- ▶ W-CDMA Deployment



Country

Home | Operators | Technology | Training | Events | Contact us
copyright 2005, African CDMA Discussion Forum

AFRICAN CDMA FORUM
Online CDMA technology Resource & Discussion Forum

AFRICAN CDMA FORUM | Online CDMA Technology Resource & Discussion Forum

A place where you can find & share information regarding CDMA operators, hardware, software & Hot Jobs in CDMA all over Africa

OPERATOR TECHNOLOGY TRAINING FORUM

CDMA OPERATORS

PROSPECTIVE 800 MHZ DEPLOYMENTS (DEC'06)

MORE LINKS

- CDMA Deployment Map
- 450 MHz Current Deployment
- Prospective 450 MHz (Dec 06)
- 800 MHz Current Deployment
- Prospective 800 MHz (Dec 06)
- 1900 MHz Current Deployment
- W-CDMA Deployment

Country

Home | Operators | Technology | Training | Events | Contact us | AFRICAN CDMA FORUM
copyright 2005, African CDMA Discussion Forum Online CDMA technology Resource & Discussion Forum

**Mobile phones
increase GDP
1% = \$240**

Impact of Improving Telephony Connectivity

It is not just about Voice...

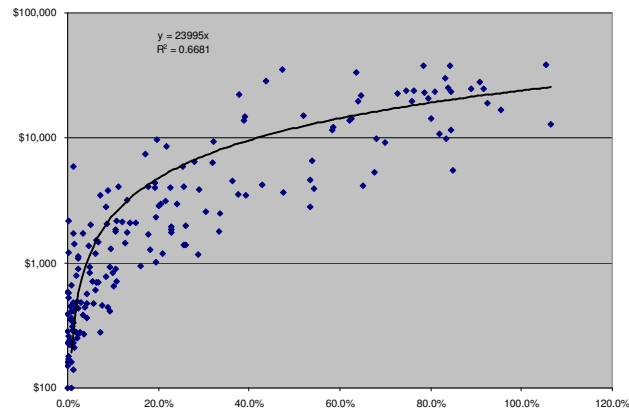

For each 1% increase in Mobile penetration, GDP per capita goes up by US\$240

Source: Michael Minges, TMG Telecom, and ITU World Telecommunications Database Statistics, 2003.

Data even
more so
1% = \$593

Impact of Improving Connectivity

It is about voice and data...

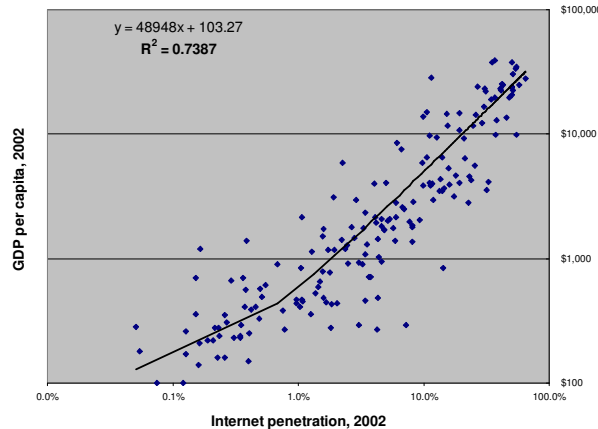

For each 1% increase in Internet penetration, GDP per capita goes up by US\$593

Source: Michael Minges, TMG Telecom, and ITU World Telecommunications Database Statistics, 2003.

There is a silent **tsunami** under way all the time in rural Africa. Every month, as many children die of malaria in Africa as died in the tsunami – about **150,000 children dying every month.**”

Beyond Voice is the World of Mobile Data

- *Non-voice Applications are Driving Wireless Growth*



What part will 4G play?

- What is 4G?
- What role will IP play?
- What role will wireless play?