



ITU-D REGIONAL DEVELOPMENT FORUM FOR  
AFRICA REGION: NGN AND BROADBAND  
OPPORTUNITIES AND CHALLENGES

# NGN Planning and Migration

*Prof. dr Natasa Gospic,*  
University Belgrade  
*Riccardo Passerini,* ITU-D

Lusaka, Zambia 18-19 May 2009

## Guidelines on migration of existing networks to Next-Generation Networking (NGN) for developing countries

- **Question 19-1/2** of ITU-D Study Group 2 (Study Period 2006-2010)
- Migration to NGN is a complex issue and it is not expected that these guidelines provide any comprehensive technical tutorial on this subject.
- It will offer basic principles to support the path to full NGN

Lusaka, Zambia 18-19 May 2009

## ITU-D SG 1 – NGN REGULATORY ASPECT

- **Question 6-2/1:** Regulatory impact of **next-generation networks** on interconnection
- **Question 12-2/1:** Tariff policies, tariff models and methods of determining the costs of services on national telecommunication networks, including next-generation networks

Lusaka, Zambia 18-19 May 2009

## Trends in Telecommunication Reform

- 2007: "The Road to Next-Generation Networks (NGN)" includes:
  - Ch 1: Market trends
  - Ch 2: NGN-A regulation overview
  - Ch 3: NGN Technology
  - Ch 4: FMC
  - Ch 5: Interconnection in an IP-based environment
  - Ch 6: International interconnection, NGN and ICT development
  - Ch 7: NGN and US
  - Ch 8: Consumer Protection and QoS
  - Ch 9: Enabling environment for NGN
  - Ch 10: Why NGN, Why Now

Lusaka, Zambia 18-19 May 2009

## **Best Practice Guidelines for Next-Generation Networks (NGNs) Migration**

- **Global Symposium for Regulators (GSR), Dubai, February 2007 refers to:**
  - An enabling regulatory regime that fosters innovation, investment and affordable access to NGNs and facilitates migration to NGNs
  - Innovative Regulatory Policies Must Be Developed To Facilitate NGNs

<http://www.itu.int/ITU-D/treg/bestpractices.html>

Lusaka, Zambia 18-19 May 2009

## **Best Practice Guidelines on Innovative infrastructure sharing strategies to promote affordable access for all**

- **Global Symposium for Regulators (GSR) , Pattaya, Thailand, March 2008**
- **A. Promoting an enabling environment**
  - 1. Appropriate Regulatory framework
  - 2. Competition and investment incentives
- **B. Innovative regulatory strategies and policies to promote infrastructure sharing**
  - 1. Reasonable terms and conditions
  - 2. Pricing
  - 3. Efficient use of resources
  - 4. Scarce resources
  - 5. Licensing
  - 6. Conditions for sharing and interconnection
  - 7. Establishing an infrastructure sharing one-stop-shop
  - 8. Improving transparency and information sharing
  - 9. Dispute resolution mechanism
  - 10. Universal access
  - 11. Sharing with other market players and industries

<http://www.itu.int/ITU-D/treg/bestpractices.html>

Lusaka, Zambia 18-19 May 2009

## Other useful information

- The 2007 Global Symposium for Regulators Best Practice Guidelines on Next Generation Networks migration, available at <http://www.itu.int/ITU-D/treg/bestpractices.html> and also a contribution to ITU-D Question 19-1/2 in Document 1/090.
- GSR Discussion Paper on NGN Interconnection and Access, prepared by Scott Marcus, available online at [http://www.itu.int/ITU-D/treg/Events/Seminars/GSR/GSR07/discussion\\_papers/JScott\\_Marcus\\_Interconnection\\_IP-based.pdf](http://www.itu.int/ITU-D/treg/Events/Seminars/GSR/GSR07/discussion_papers/JScott_Marcus_Interconnection_IP-based.pdf)
- Scott Marcus presentation to GSR 2007 [http://www.itu.int/ITU-D/treg/Events/Seminars/GSR/GSR07/Documents\\_presentations/Session\\_III%20Scott%20Marcus\\_interconnect.pdf](http://www.itu.int/ITU-D/treg/Events/Seminars/GSR/GSR07/Documents_presentations/Session_III%20Scott%20Marcus_interconnect.pdf)
- [Workshop on NGN Interconnection in the Arab Region](http://www.itu.int/ITU-D/treg/Events/Seminars/2007/Bahrain/agenda.html), Manama, Bahrain, May 2007, all presentations available at <http://www.itu.int/ITU-D/treg/Events/Seminars/2007/Bahrain/agenda.html>
- TREG link to NGN resources at <http://www.itu.int/ITU-D/treg/related-links/links-docs/NGN.html>
- Other Resources on NGN Interconnection
- The European Regulators' Group Opinion on Regulatory Principles of Next Generation Access [http://erg.ec.europa.eu/doc/publications/erg07\\_16rev2\\_opinion\\_on\\_nga.pdf](http://erg.ec.europa.eu/doc/publications/erg07_16rev2_opinion_on_nga.pdf)
- The Future of IP Interconnection, 29 January 2008, WIK Consulting, [http://ec.europa.eu/information\\_society/policy/ecomms/doc/library/ext\\_studies/future\\_ip\\_intercon/ip\\_intercon\\_study\\_final.pdf](http://ec.europa.eu/information_society/policy/ecomms/doc/library/ext_studies/future_ip_intercon/ip_intercon_study_final.pdf)
- NGN UK website <http://www.ngnuk.org.uk/>

Lusaka, Zambia 18-19 May 2009

## NGN Definition

- Packet-based network
- Offers range of services and able to make use of multiple broadband transport technologies.
- Service-related functions are independent from transport technologies
- Enables users to access by various means
- Competitive networks, competing service providers, and services of choice
- Supports generalized mobility allowing users access to consistent services regardless of where they are
- Quality of Service based on speed, accuracy, reliability, and security of communication

Lusaka, Zambia 18-19 May 2009

## Universal service in NGN environment

### ■ TRIGGERS

- ◆ Capability of NGNs to replace all existing networks
- ◆ Value of NGNs to consumers
- ◆ Impact of capacity variations on take up
- ◆ Social value to tackle digital divide
- ◆ Phases of NGN development

### ■ ISSUES

- ◆ Switch-over as public policy services and NGN services
- ◆ Scope of USO over NGNs
- ◆ Uneven development of NGNs
- ◆ Co-existence of legacy universal and NGN services

Lusaka, Zambia 18-19 May 2009

## NGN SERVICES

- **PSTN-ISDN Emulation:**
  - ◆ Supports legacy phones on an all-IP network leading to operational advantages.
- **PSTN Multi-Media telephony**
  - ◆ Provides PSTN/ISDN-like voice, video, data calls on IP-phones, PC, mobiles, handheld
- **Messaging and Presence**
  - ◆ Instant Messaging, MMS
- **Value Added Services**
  - ◆ can be provided by third party
- **IP-TV**
  - ◆ Video-on-Demand (VOD), near-VOD, Time-shifted TV, Broadcast TV.
- **Regulatory requirements**
  - ◆ NP, Emergency call, Lawful intercept, Data privacy, Data retention

Lusaka, Zambia 18-19 May 2009

## Series Y.2... related NGN Recommendations

Y.2000–Y.2099	Frameworks and functional architecture models
Y.2100–Y.2199	Quality of Service and performance
Y.2200–Y.2249	Service aspects: Service capabilities and service architecture
Y.2250–Y.2299	Service aspects: Interoperability of services and networks in NGN
Y.2300–Y.2399	Numbering, naming and addressing
Y.2400–Y.2499	Network management
Y.2500–Y.2599	Network control architectures and protocols
Y.2600–Y.2699	dealing with future packet based networks
Y.2700–Y.2799	Security
Y.2800–Y.2899	Generalized mobility
Y.2900–Y.2999	dealing with the carrier grade open environment

Lusaka, Zambia 18-19 May 2009

## Example of Recs(\*) approved, consented & determined in Seoul, January 2008.

Y.2001	General overview of NGN
Y.2011	General principles and general reference model for next generation networks
Y.2012	(Y.NGN-FRA) Functional requirements and architecture of the NGN
Y.2012 Cor.1	Functional requirements and architecture of the NGN, Corrigendum 1
Y.2012 Amd.1	Functional requirements and architecture of the NGN, New Appendix III, Instantiation of NGN reference points
Y.2013	(Y.CSF) Converged services framework functional requirements and architecture
Y.2014	(Y.NACF-R1) Network attachment control functions in Next Generation Networks
Y.2021	(Y.IFN) IMS for Next Generation Networks
Y.2031	(Y.PIEA) PSTN/ISDN emulation architecture
Y.2041	Y.NGN-R1) Description of capability set 1 of NGN release 1
Y.2051	(Y.ngn-ipv6) General overview of IPv6-based NGN
Y.2052	(Y.ipv6-multi) Framework of multi-homing in IPv6-based NGN
Y.2053	(Y.ipv6-transit) Functional requirements for IPv6 migration in NGN
Y.2054	(Y.ipv6-sig) Framework to support signalling for IPv6-based NGN
Y.2091	(Y.2091 (revised)) Terms and definitions for Next Generation Networks

Lusaka, Zambia 18-19 May 2009

# NGN

- From a technology perspective, NGN is based on:
  - a new architecture that modifies both the core and access parts of a telecommunication network and changes the way it delivers services to end-users.

Lusaka, Zambia 18-19 May 2009

## NGN General Reference Model

Pre-NGN:  
Vertically  
Integrated  
Networks

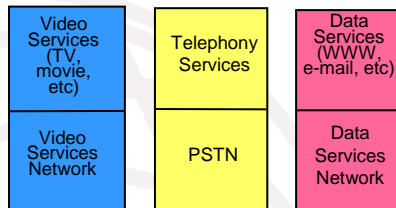

NGN:  
Horizontally  
Integrated  
Networks

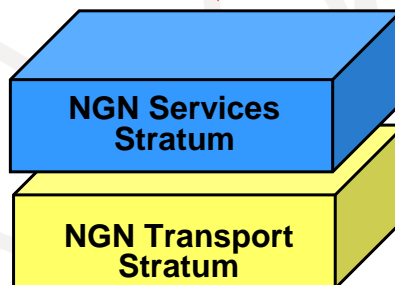

Recommendation  
Y.2011:

Lusaka, Zambia 18-19 May 2009

# NGN architecture described in ITU-T Y.2012

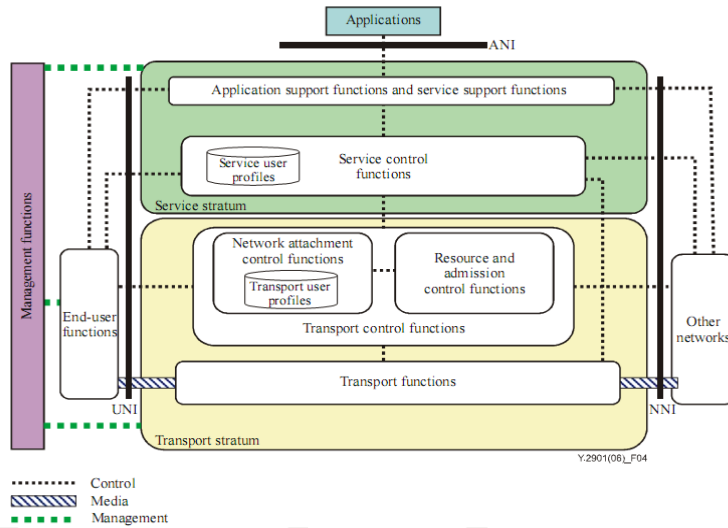

Lusaka, Zambia 18-19 May 2009

## A generic NGN architecture

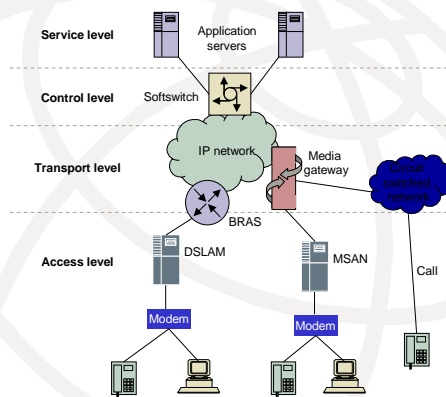

•NGN borrows many technological building blocks from the Internet, but

•NGN is a new architecture for the evolution or replacement of current fixed and mobile telephony networks, and

•NGN will ultimately lead to a new network concept blending the openness and flexibility of the Internet with the quality guarantees inherent in the traditional Public Switched Telephone Network (PSTN) which will be extended beyond voice to any multimedia or content delivery service

Lusaka, Zambia 18-19 May 2009



## Where and how to start?

- From drivers for NGNs
  - Cost and network reduction
  - Revenue generation and protection
  - FMC
  - IMS
  - Access migration.
- Following examples from developed countries
- EVOLUTIONARY OR REVOLUTIONARY
- TOP-DOWN or BOTTOM-UP APPROACH

Lusaka, Zambia 18-19 May 2009

## Flow chart of international network planning process

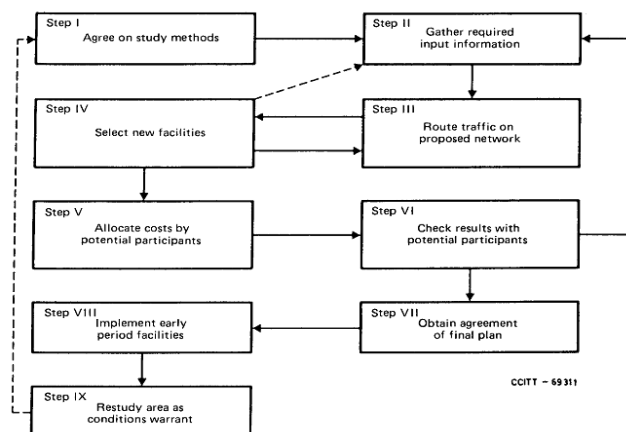

Source ITU-T Rec. E.175

Lusaka, Zambia 18-19 May 2009

## ITU-D deliverables

- Manual on Telecom Network Planning for Evolving Network Architectures Version 04, ITU, 2008.
- Guidelines for Network Planning Tools
- for Developing Countries and Countries
- with economies in transition, ITU, 2005
- link :  
<http://www.itu.int/ITU-D/tech/network-infrastructure/index.html>

Lusaka, Zambia 18-19 May 2009

## HOW TO PLAN MIGRATION TO NGN ?

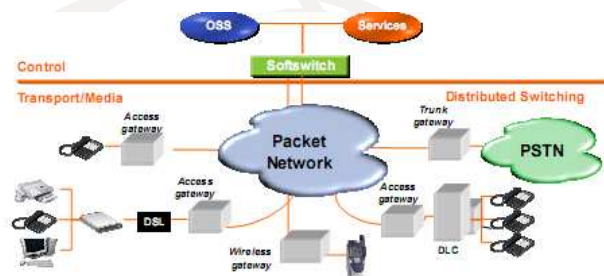

From ITU-T specification Y.2261: PSTN/ISDN  
Evolution to NGN

“Evolution to NGN: A process in which *whole or parts* of the existing networks are *replaced* or upgraded to the corresponding NGN components providing *similar or better* functionality, while attempting to *maintain* the services provided by the original network and the possibility of *additional capabilities*”

**Migration to NGN synonymous to evolution to NGN**

Lusaka, Zambia 18-19 May 2009

## ITU-T RECOMMENDATIONS

- Recs Y.2261, Y.2262 and Y.2271 provides some functional guidelines for NGN migration with a focus on emulating existing PSTN/ISDN network
- Example scenarios from Rec. Y.2261
  - Call Server (SoftSwitch) based approach of the Core network with three variants (scenarios):
    - **Scenario 1:** Migration starts from Local Exchanges (LE)
    - **Scenario 2:** Migration starts from Transit Exchanges (TE)
    - **Scenario 3:** One-step approach

Lusaka, Zambia 18-19 May 2009

## Scenario 1: Migration from LE

- **Step 1**
  - Some of the LEs are replaced by Access Gateways (AG) controlled by a Call Server (CS).
  - Access elements originally connected to the removed LEs, are now directly connected to AGs : PABXs and Access Nodes (AN).
  - User Access Modules Functionality (UAM) assumed by AG and CS.
  - Trunking Media Gateways (TMG) and Signaling Gateways (SG) are deployed for interconnection between the PSN and the TEs of the legacy network as well as other operators' PSTNs/ISDNs.
  - AGs and TMGs are all controlled by the CS.
- **Step 2**
  - Remaining LEs are replaced by the AGs,
  - Transit Exchanges (TE)s are removed and their control functions are performed by CS.
  - TMGs and SGs are deployed for interconnection between PSTN and other operators' PSTNs/ISDNs.
  - AGs and TMGs are all controlled by the CS.

Lusaka, Zambia 18-19 May 2009

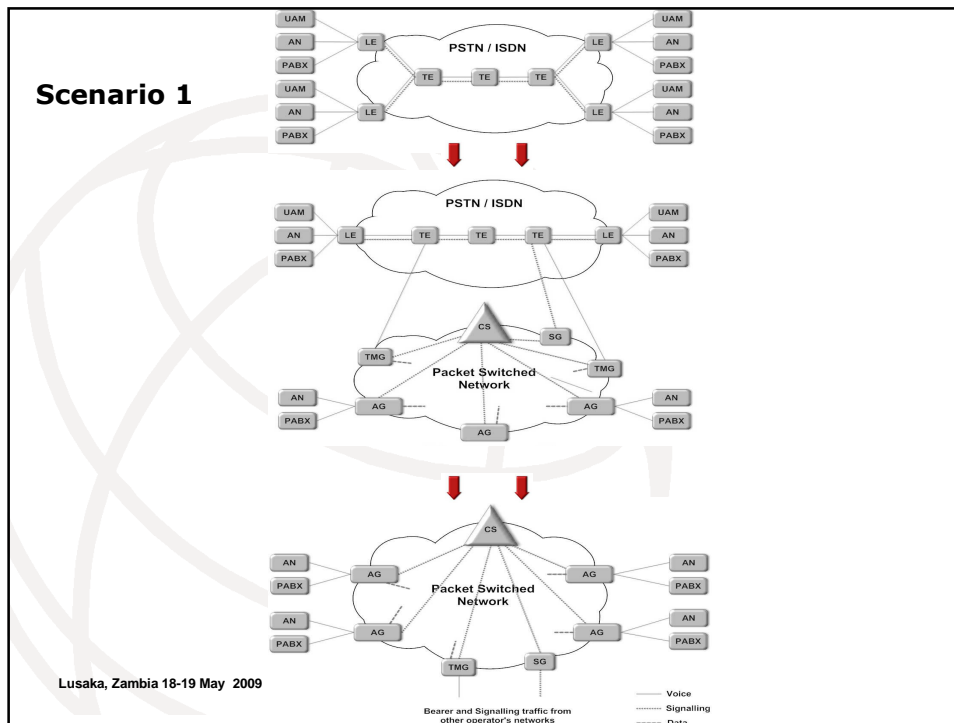

## Scenario 2: Migration from TE

### Step 1

- ◆ All TE functions are performed by the TMGs and the SGs under the control of the CS.
- ◆ LEs are connected to the Packet Switched Network (PSN) via TMGs and SGs.
- ◆ TMGs & SGs are deployed for interconnection between PSN and other operators' PSTNs/ISDNs.
- ◆ AGs & TMGs are all controlled by CS.

### Step 2

- ◆ All LEs are replaced by AG controlled by CS
- ◆ Access elements originally connected to the removed LEs, are now directly connected to AGs : PABXs and Access Nodes (AN).
- ◆ User Access Modules Functionality (UAM) assumed by AG and CS.
- ◆ TMGs & SGs are deployed for interconnection between PSN and other operators' PSTNs/ISDNs.
- ◆ AGs & TMGs are all controlled by CS.

## Scenario 2

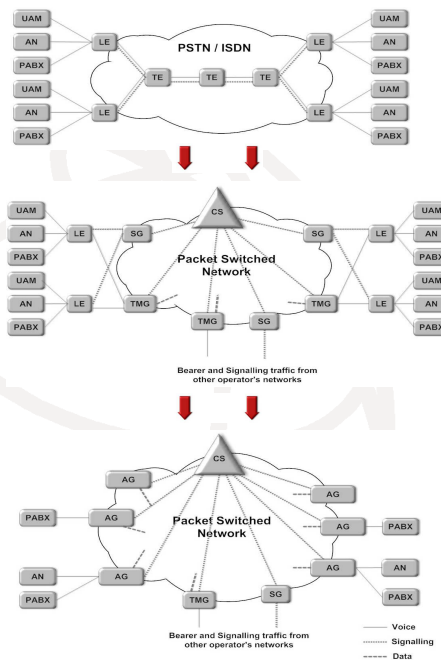

Lusaka, Zambia 18-19 May 2009

## Scenario 3: One-Step Approach

- LEs are replaced by the AGs and their functions are transferred to the AGs and the CS.
- All access elements such as user access modules (UAMs), remote user access modules (RUAMs), and private automatic branch exchanges (PABXs) are connected to access gateways (AGs).
- The access networks (ANs) are either replaced by the access gateways (AGs) or are connected to packet based network (PBN) through the AGs.
- Transit gateways (TMGs) under the control of the call server (CS), and the signalling gateways (SGs), are deployed to replace the TE functions and provide interconnection between PSN and other operators' PSTNs/ISDNs.

Lusaka, Zambia 18-19 May 2009

### Scenario 3

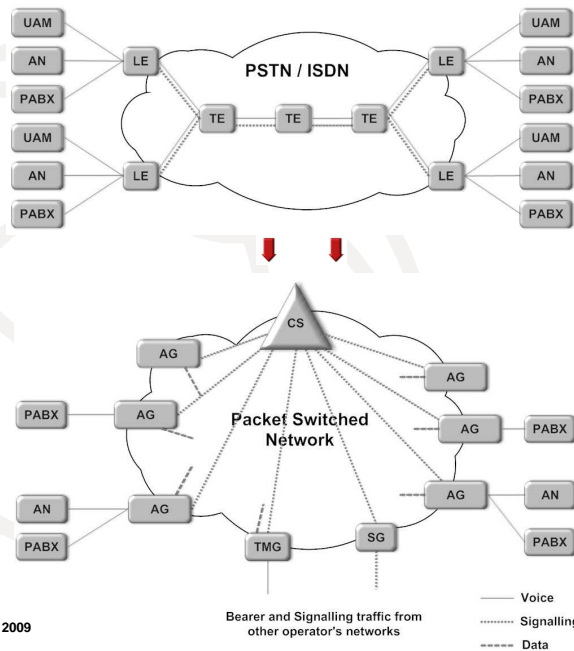

Lusaka, Zambia 18-19 May 2009

### IMS-based evolution to NGN

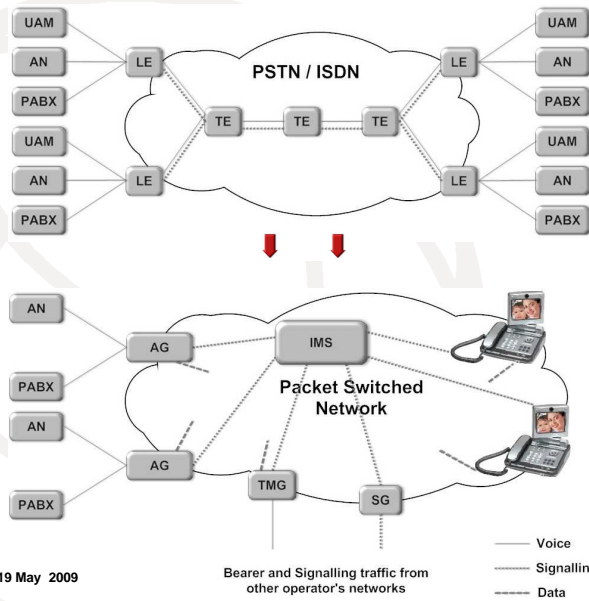

Lusaka, Zambia 18-19 May 2009

## Convergence Strategy Evolution to IMS: Phases

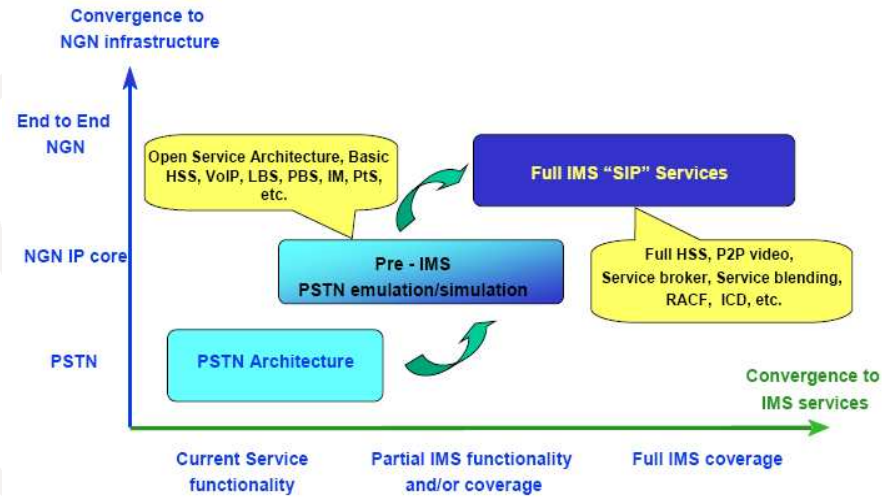

Source: S.O Gonzales, BWA, Moscow, 2007

Lusaka, Zambia 18-19 May 2009

## Example of NGN progress

Operator	Start	Plans
<b>BT</b>	<ul style="list-style-type: none"> <li>■ 2004 vision</li> <li>■ 2007 migration of customers to NGN in trail areas Wales</li> </ul>	<ul style="list-style-type: none"> <li>■ Full migration in 2011</li> </ul>
<b>France Telecom</b>	2005, NGN plans in France Telecom strategy	<ul style="list-style-type: none"> <li>■ France Telecom aims to have fully integrated its IT and networks into an NGN/IMS architecture by 2008</li> <li>■ To begin offering new NGN/IMS convergent services from 2008 onwards.</li> </ul>
<b>KPN</b>	March 2005 NGN Strategy	KPN hopes to complete its NGN backbone and the majority of its access network by 2010
<b>SA Telecom</b>	<ul style="list-style-type: none"> <li>■ NGN strategy in 2006.</li> <li>■ From 2008, Telkom SA begins selective PSTN migrations and increase core bandwidth to 10Gbps</li> </ul>	Anticipates full migration beyond 2011.

Lusaka, Zambia 18-19 May 2009

# France Telecom Evolutionary Strategy

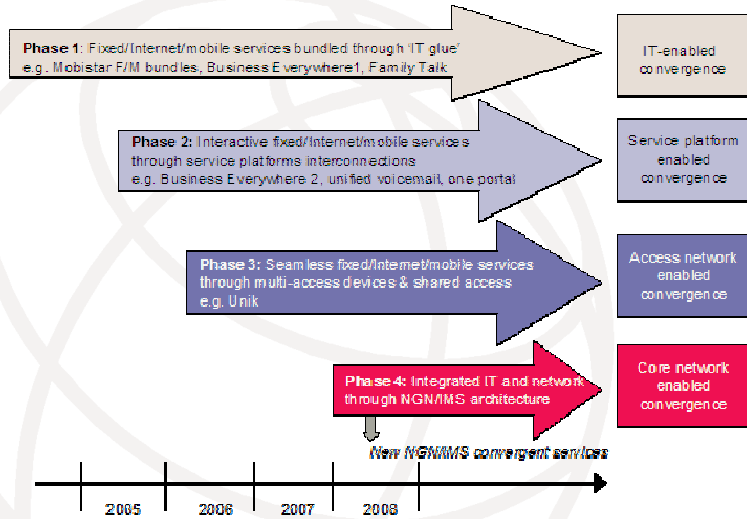

Source: France Telecom

Lusaka, Zambia 18-19 May 2009

# Different approaches to IMS implementation

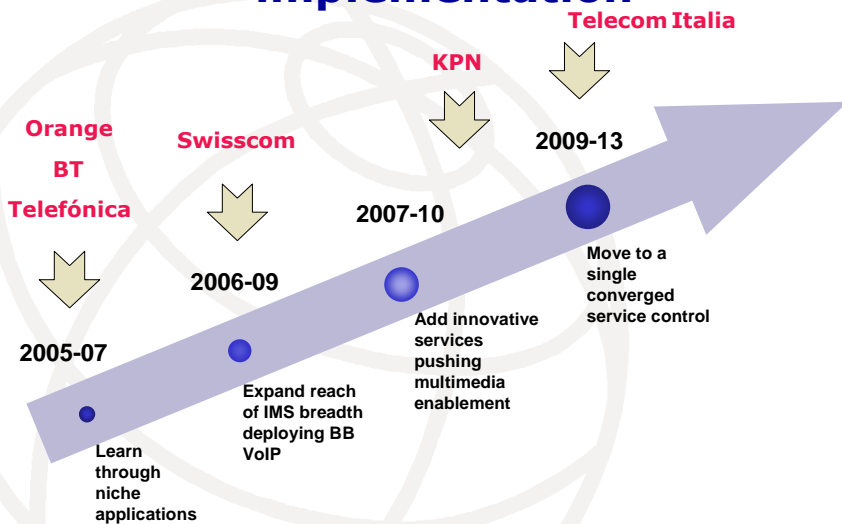

Source: Operators

Lusaka, Zambia 18-19 May 2009



## AN EXAMPLE OF NGN MIGRATION STRATEGY IN DEVELOPING COUNTRY: Operator Telekom Srpske

The market is regulated by the Communication Regulatory Agency – CRA, and Telekom Srpske is one of the three incumbent operators in Bosnia & Herzegovina (Telekom Srpske, BH Telecom and HT Mostar).

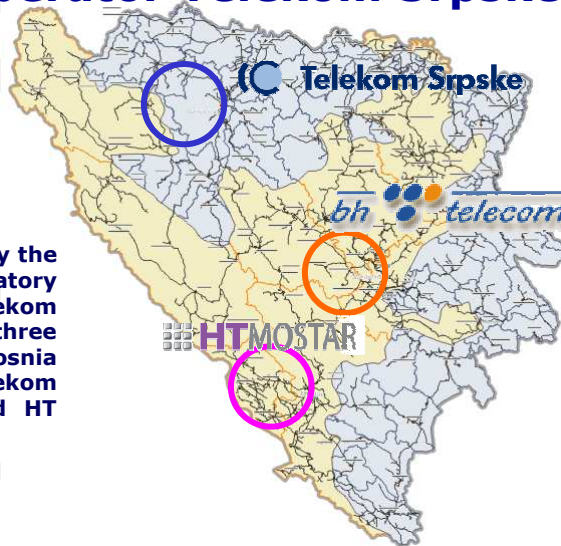

Lusaka, Zambia 18-19 May 2009

## Telekom Srpske Business Strategy

- Telekom Srpske is a small operator (fixed, mobile, Internet)
- Telekom Srpske plans to:
  - consolidate PSTN network
  - increase the number of telephone lines
  - offer new services and applications
- Projects:
  - Building DWDM/OTN Transport Network
  - Further Development MPLS Network
  - Fixed Network Redesign
  - Deploying NGN network
  - Deploying UMTS
  - IN platform



Lusaka, Zambia 18-19 May 2009

## Telecom Srpske-Migration to NGN

- New services are based on the NGN and IMS architecture.
- Strategy
  - ◆ parallel existence of TDM and NGN network till full migration to NGN (Year 2012.)
  - ◆ 75.000 PSTN users are migrated to Softswitch using MSAN platform - preserving all PSTN services (the end of the 2008).
  - ◆ Solutions consisting of IMS Core elements and Softswitch
- NGN Techno-Economic Aspects
  - ◆ Investment protection
  - ◆ Costs reduction (capital and operational)
  - ◆ Carrier grade reliability
  - ◆ Scalability
  - ◆ Improved product selection
  - ◆ Increase usage of the existing network infrastructure
  - ◆ Speed of innovation and introduction of services

Lusaka, Zambia 18-19 May 2009

## Telekom Srpske-Strategy to NGN First Step

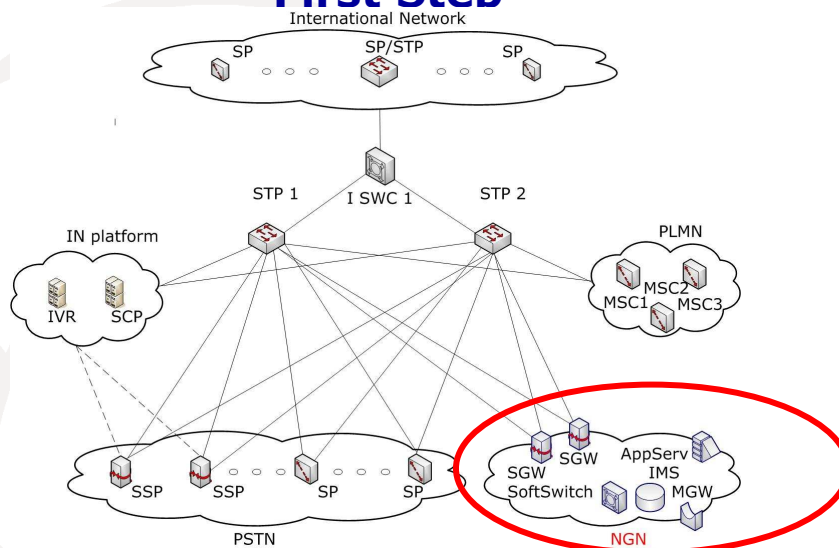

Lusaka, Zambia 18-19 May 2009

## Realization of the Logical Network Architecture Access & Inter-Working Layer in Telecom Srpske network

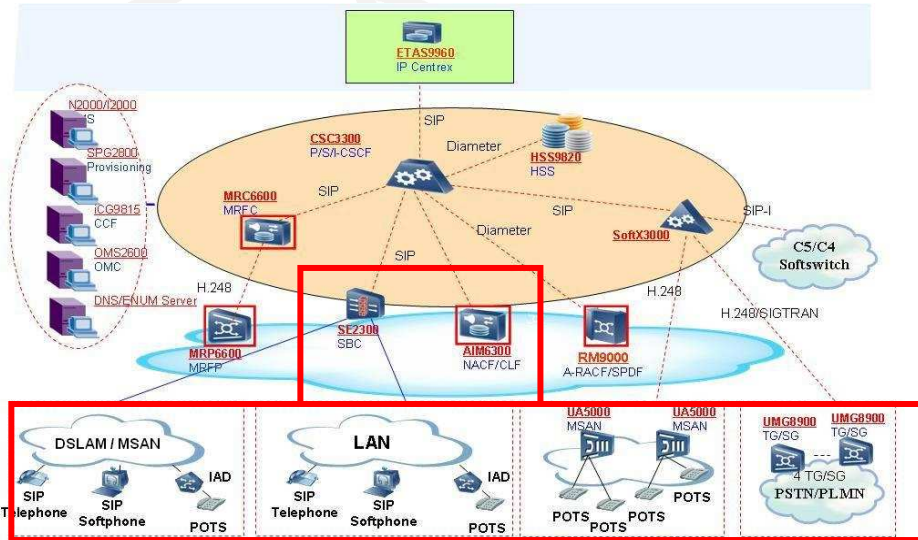

Lusaka, Zambia 18-19 May 2009

## Access & Inter-Working Layer

- Access & inter-working layer is essential for providing IP connectivity to the end user.
- SE2300, SBC (Session Boarder Controller) provides the necessary NAT translation function between core network and access network.
- AIM6300, NACF&CLF (Network Access Configuration Function & Connectivity Session Location Function), performs several functions such as:
  - ◆ assigning IP address to terminal in access network
  - ◆ providing necessary access network configuration information to terminal
  - ◆ providing terminal location information in fixed access
  - ◆ (identification of DSLAM and port on the DSLAM)

Lusaka, Zambia 18-19 May 2009

## Telecom Srpske: Next Steps in migration to NGN

- Full migration of PSTN users from TDM to NGN using MSAN and Softswitch platform (2012.)
- Offering new services: Video Call, Video Conference, Unified Messaging, Presence and Instant Messaging etc.
- Interconnection with the international VoIP networks
- FMC - Fixed Mobile Convergence

Lusaka, Zambia 18-19 May 2009

## Telecom Srpske-Broadband Access

- Triple - Play services in Telekom Srpske network will be provided to end user through broadband access based on xDSL, FTTH technology
- Separation of services and QoS will be achieved using PVCs, VLANs
- Voice services will be provided through IMS, part of NGN network
- 51.760 xDSL ports will be present in the network by the end of this year:
  - 49.616 ADSL2+
  - 2.144 SHDSL

Lusaka, Zambia 18-19 May 2009

## Telecom Srpske-MPLS Services

- MPLS is based on:
  - Dark Fiber
  - DWDM
  - SDH
- Present Core routers throughput is 10 Gbps.
- Current services:
  - Layer 3 VPN (VPRN)
  - Layer 2 VPN (VPLS)
  - Point-to-point links (VLL)
- In order to provide NGN services separation and QoS, Layer 3 VPN service will be used.

Lusaka, Zambia 18-19 May 2009

## Transport Network – MPLS

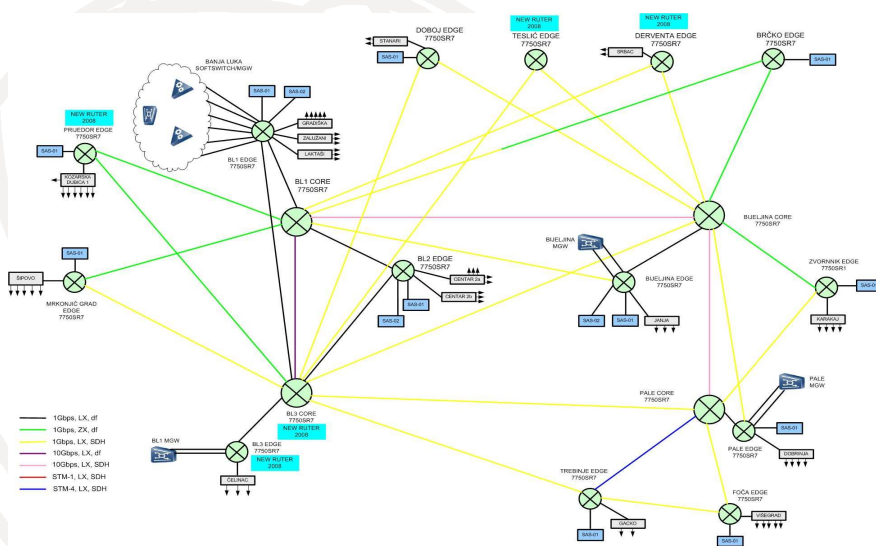

## Transport Network - Interconnections

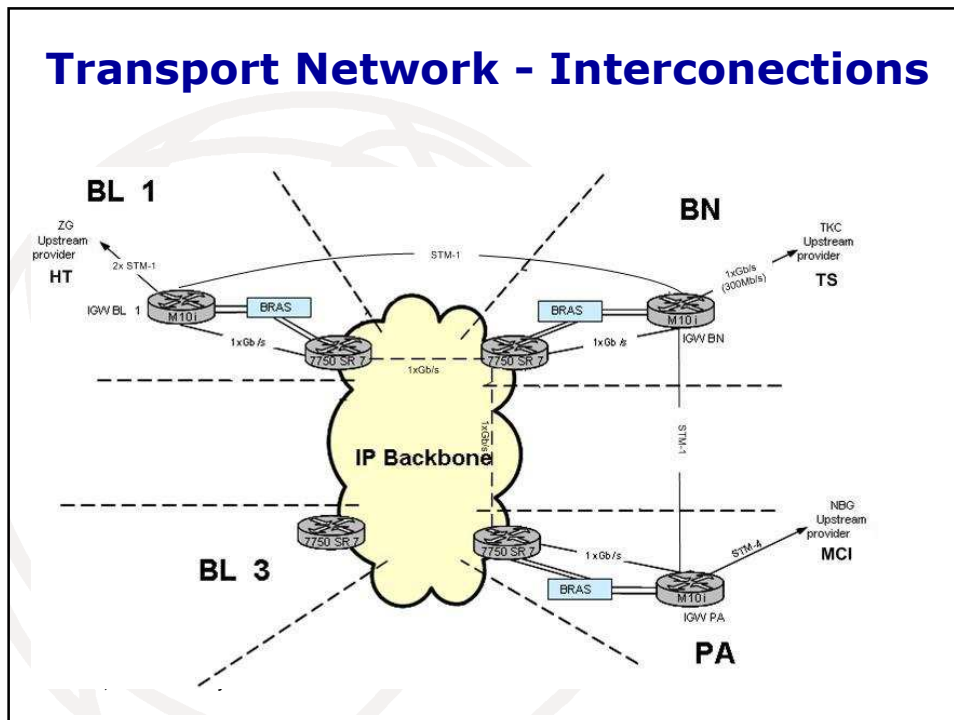

## The main conclusions (draft of Guidelines on migration to NGN)

- Individual NGN building blocks are mature but their integration is not. NGN standards offer a first glimpse at how some of those building blocks will be integrated but there is still a lot more work to be done. Developing countries can observe current NGN deployments in developed countries to learn how difficulties can be overcome.
- NGN is technologically at the intersection of the Internet and the PSTN. It tries to blend the flexibility and openness of the former with the quality guarantees inherent in the latter. It is likely, however, that quality will come at a price and next-generation networks will co-exist with a cheaper but less secure Internet.
- NGN migration is beginning in developed countries, incurring huge investments. Whether these investments will pay off is the multi-billion dollar question. However, these investments appear to be grounded on realistic cost reduction objectives and revenue projections.
- Last but not least, NGN will raise significant challenges for regulators. Issues of market definition, service definition, interconnection and QoS, to name but a few, will be much more complex than that in the "old world" of telephony.

## The road to NGN for developing countries 1/2

- May take many paths.
- But developing countries also have certain advantages in the migration process to NGN.
- Compared to more developed markets, service providers in the developing world generally have fewer legacy products in their core networks (for example, ISDN, IP, ATM, FR, and SHDS). This makes it easier for them to "leapfrog" to all IP-based systems.
  - ◆ Limited deployment and penetration of copper networks, and the falling cost of fibre, can also facilitate "greenfield" deployment of FTTx projects.
  - ◆ In some developing countries, the absence of complex access-based *ex ante* regulations also means that there are fewer regulatory commitments to consider.

Lusaka, Zambia 18-19 May 2009

## The road to NGN for developing countries 2/2

- Developing countries should be encourage to take a part in international effort to develop best migration path to NGN.
- Valuable contribution on NGN planning methodologies from Viet Nam (Mr. Dinh Van Dzung, Ministry of Information and Communication) for Q 19-2/2

Lusaka, Zambia 18-19 May 2009



# THANK YOU FOR YOUR ATTENTION!

**Prof. dr Natasa Gospic**  
University Belgrade  
Tel: +381 11 3091310  
Email [n.gospic@sf.bg.ac.rs](mailto:n.gospic@sf.bg.ac.rs)

**Riccardo Passerini**  
Telecommunication Development Bureau  
International Telecommunication Union  
Tel.: +41 22 730 5720  
Fax: +41 22 730 5484  
Email: [riccardo.passerini@itu.int](mailto:riccardo.passerini@itu.int)  
[www.itu.int/ITU-D/](http://www.itu.int/ITU-D/)

Lusaka, Zambia 18-19 May 2009