

Government to Citizen Mass Scale
Authorised Alerting,
by 'Cell Broadcasting'.
"Its about time".

By

Mark Wood, Hon Sec, CEASa international, for;

ITU.

19 October 2006

Mark.wood@ceasa-int.org

<http://www.ceasa-int.org>

'Cell Alert' System Via Cell Broadcast.

By

Cellular Emergency Alert Service Association (CEASa) .

CEASa is a not-for-profit Voluntary organization which exists to further Humanitarian applications of Cell Broadcasting for government-to-citizen mass alerting.



mark.wood@ceasa-int.org

What the experts said;

Bangkok, February 23rd 2005:

The 'Orange Thai' president and CEO said that the company would upgrade some of its cell stations to be able to broadcast messages alerting its mobile phone users using a technique called Cell Broadcasting. After the tsunami event, Orange did not have a chance to fulfill its role to communicate to people because the capacity of its cell sites was limited, he said.

The technique will allow the operator to broadcast streaming text messages to between 100,000 and a million users a minute, he said, noting that the process took less time than to send an SMS message and that every operator should coordinate in this project in order to create an efficient nationwide warning system.

Under normal circumstances, this cell broadcasting system could also be used as a direct marketing tool, he noted."

What the experts said;

ETSI conference, Cannes, February 14th 2005:

Quotation from official statement from the European Union Commissioner for Information, Society and Media, Viviane Reading

"New applications of mobiles are constantly developing, we are currently investigating whether and how these networks could be used for early warning of the public of an imminent threat or disaster, and what further actions would need to be taken, for instance to ensure a harmonised implementation of cell broadcast across the world's GSM networks and phones."

Covered in this presentation;

- Technology
- Political issues
- International Harmonization.

There are five main points to remember about Cell Broadcast.

- Uses the 'Cell Broadcast' (Area Information) feature that most mobiles already have built in; no need to build anything.
- 'Downlink-only' true 'Broadcast' means No limit to scale; can talk to hundreds of millions at one time will not crash the networks.
- Uses capacity not taken by calls, so is immune to failure due to overloading as always happens during disasters.
- We can target individual 'cells' (Towers) so it is geo-specific. You can tell one village to evacuate and another to stay where they are.
- We can secure it so that spammers hackers and spoofers cant get in, only authorized government officials.

Cell@lert system Components

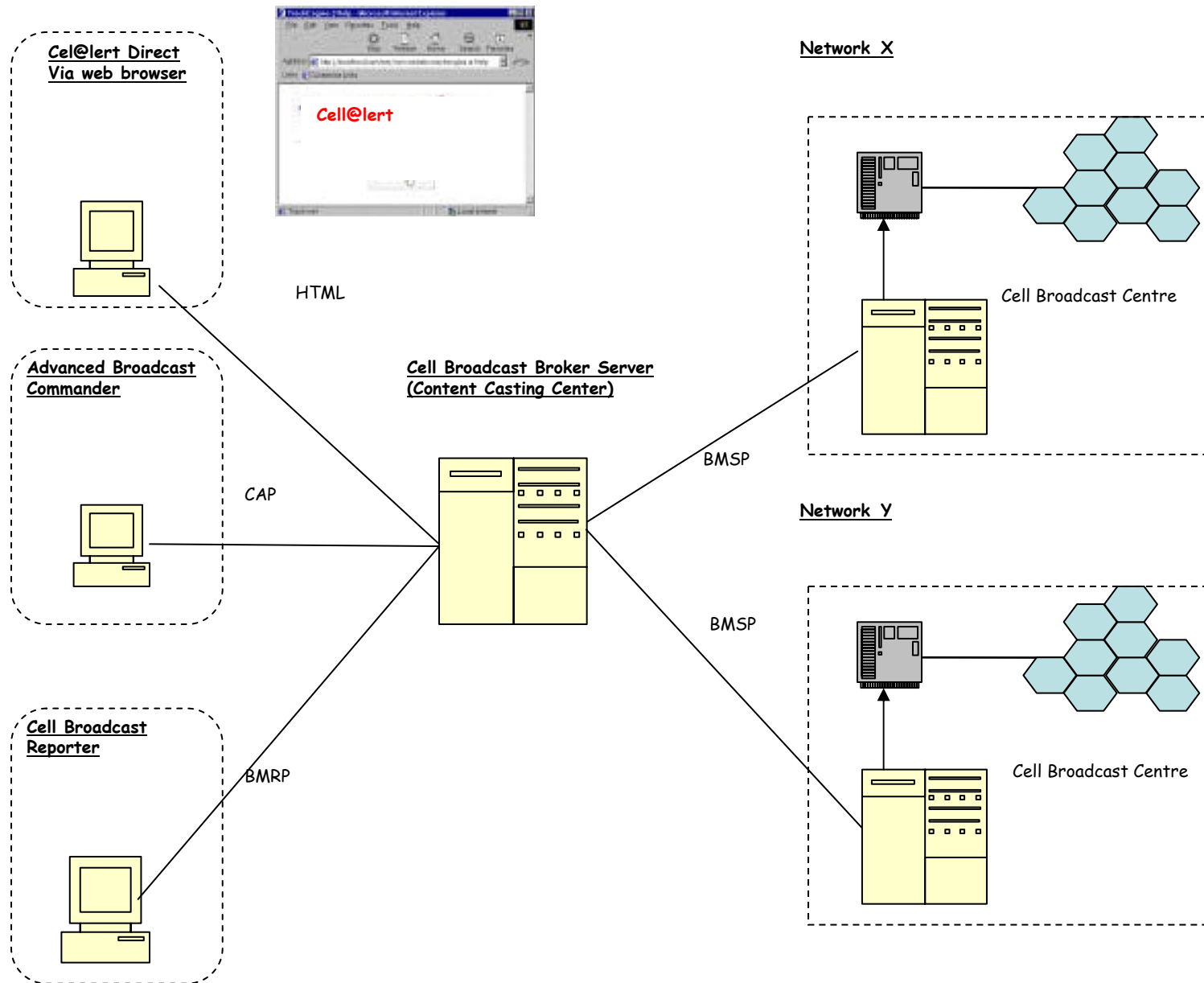

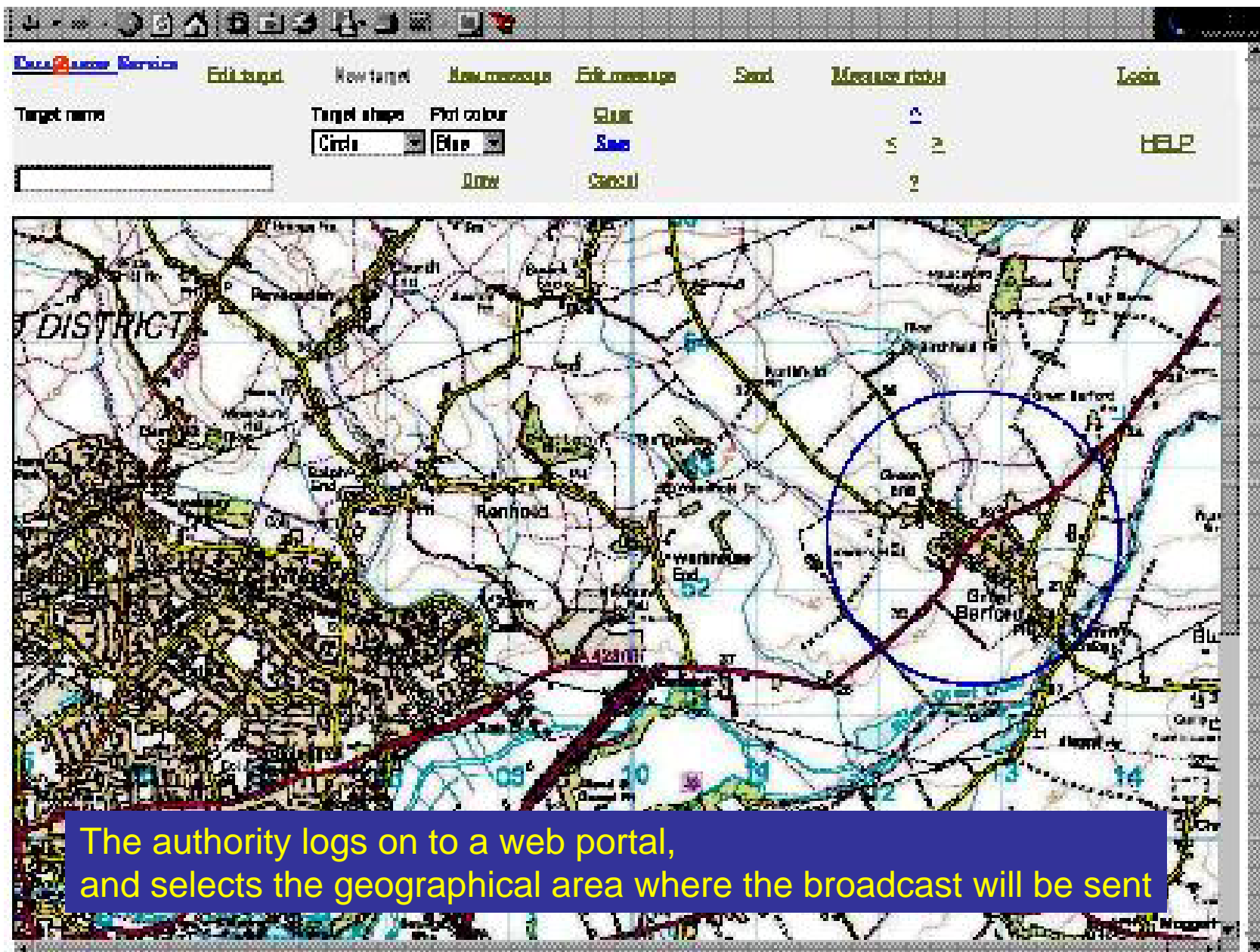

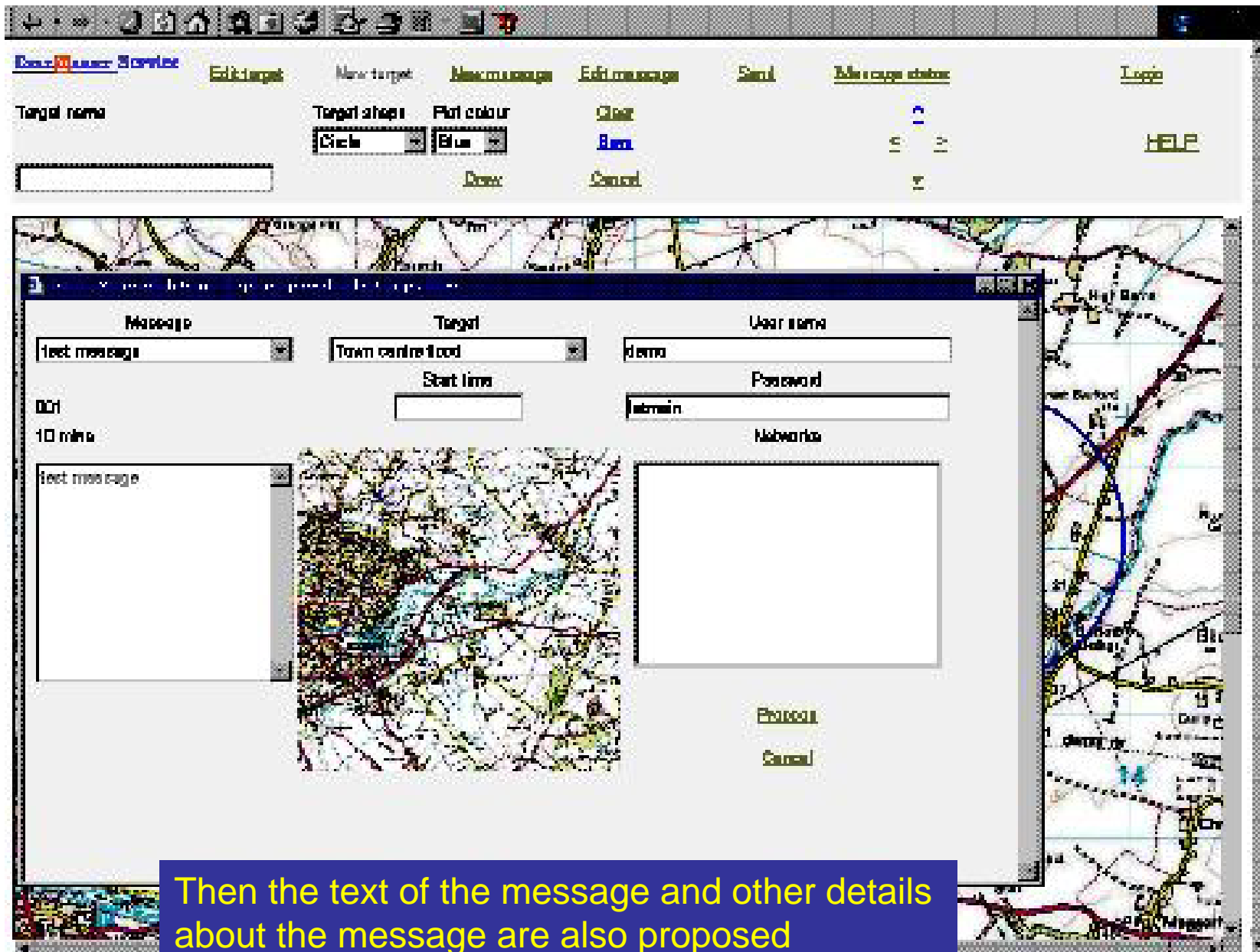

If the Broker sees that all policy has been followed, then it is reformatted and Signaled to each network in turn. It is then broadcast to all mobiles camped On the affected cells, which then alarm and display the message.

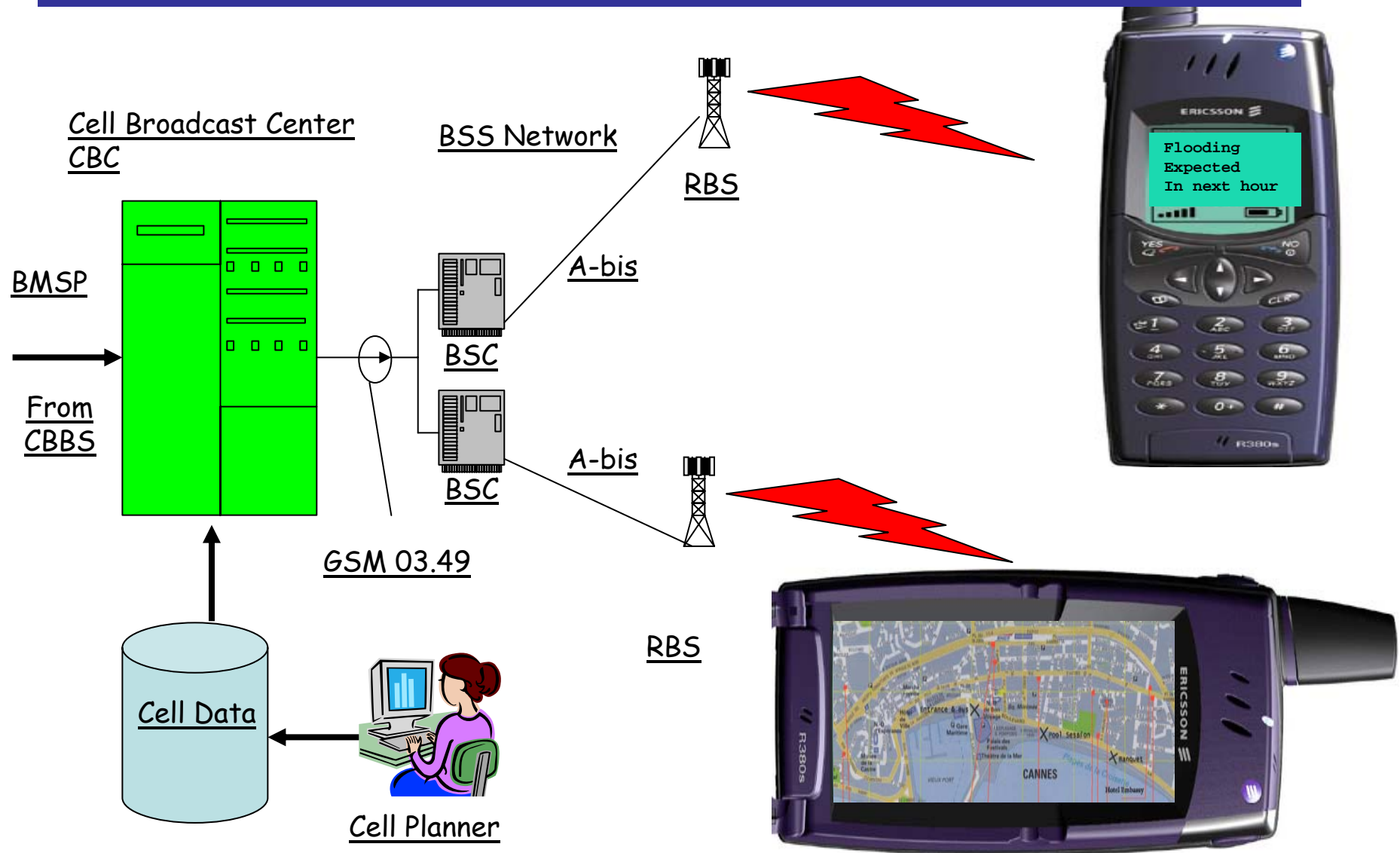

Impact on Networks

- Is not affected by, or cause congestion, uses CBCCH not TCH (not using traffic channels). So it will work even in full overload situations such as disasters.
- The Cell Broadcast feature needs to be enabled by buying the feature from the system vendor.

Impact on phones

- To enable the feature, the user can switch it on from the 'area information' menu on his phone.
- Channels can be enabled from the menu system, or by over-the-air-activation-teservice (once the feature is switched on, but right now the default is off, we need to change that).

Impact on regulation

- Urgent need for harmonized channel identification scheme to make it practical for travelers and tourists, and to prevent spamming.
- Improvements to standards needed to make sure phones give priority to emergency messages and give a distinct tone.

Political Issues;



- *Senders (e.g. Police) must be authorized by national law. Messages must be authentic and follow national policy.*
- *Resistant to Hackers Spoofers and Spammers.*
- *Not acceptable for warnings only to subscribers on one network, must be all*
- *EU law requires accountability, accordingly reporter system is part of solution.*
- *Government to Government communications in order to reach closed user groups such as off duty reservists.*

International Agencies;



- *Senders, e.g. coordinators need to have previously arranged accounts.*
- *The governments and networks must agree to this facility being made available to relief agencies, and so MoUs must be provided to control this.*
- *Can be used for call out of off duty staff.*

Proposed International 'Civic' Channels.



- *Exercise and test.*
- *Maritime service channel. (IMO)*
- *Aeronautical service channel. (ICAO)*
- *Amateur service channel. (IARU)*
- *Scientific services (eg ISNDR-PPW).*
- *UNDSS (UN Department of Safety and Security)*
- *Child security*
- *WHO (health related info)*
- *OCHA (IA Co-ordination)*
- *Red Cross/ Crescent Movement.*

Diplomatic Issues;



- *National sovereignty must be respected*
- *National systems must fully integrate with international projects.*
- *Should be complementary to but never compete with existing and proposed system.*
- *Harmonized approach to language codes.*

Cell@lert system Components

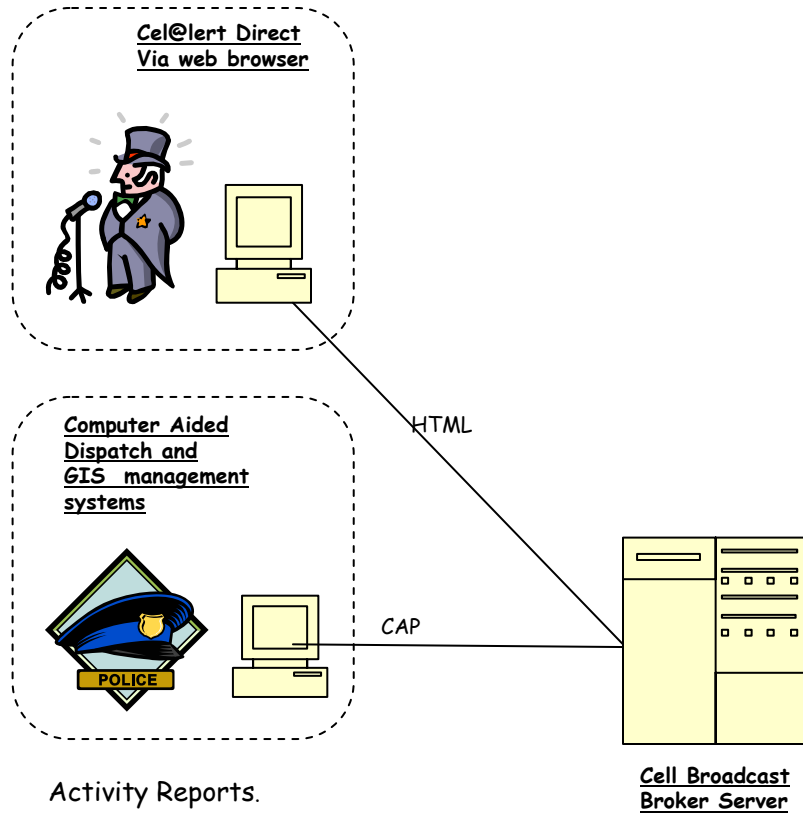

Cell@lert system Components

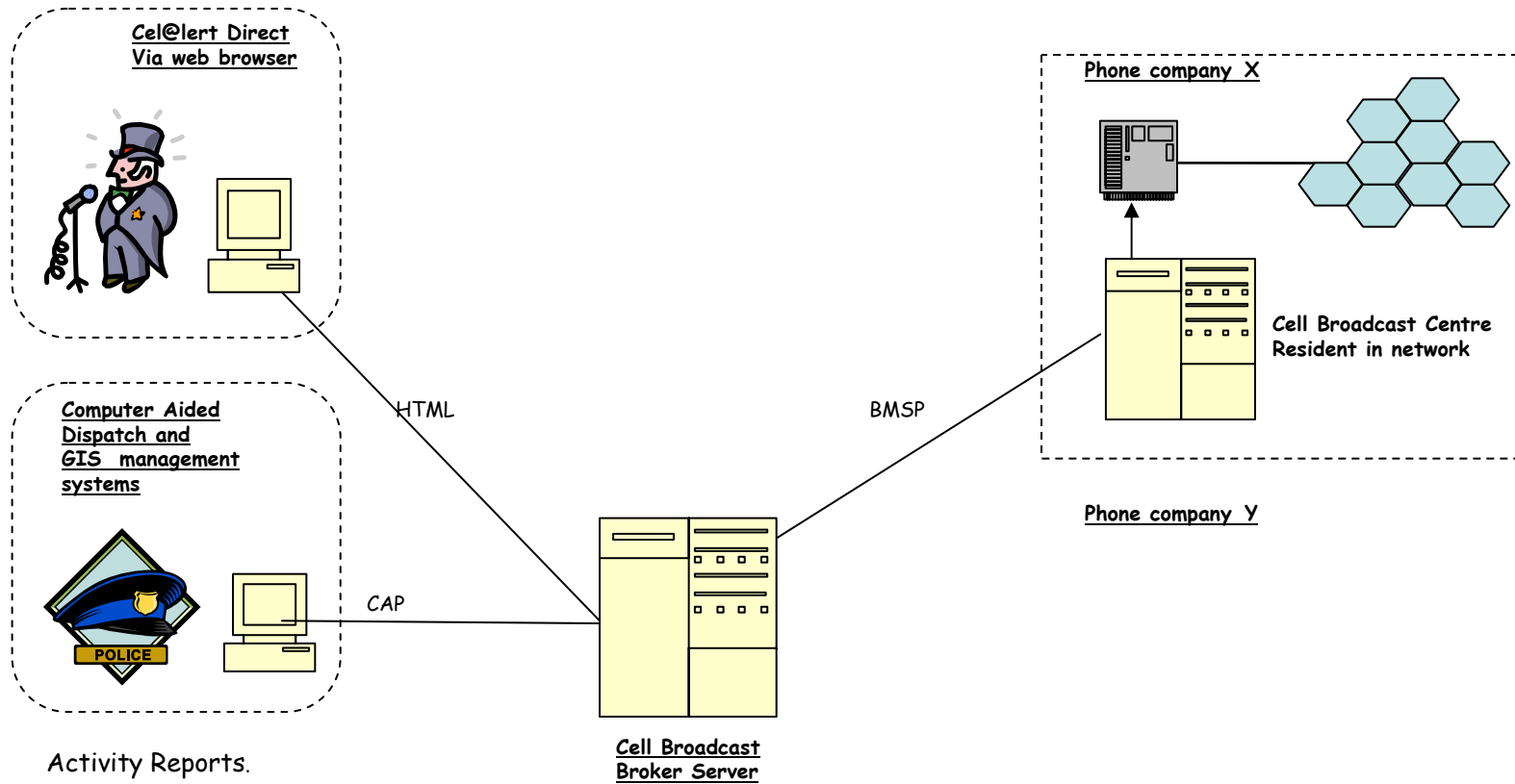

Cell@lert system Components

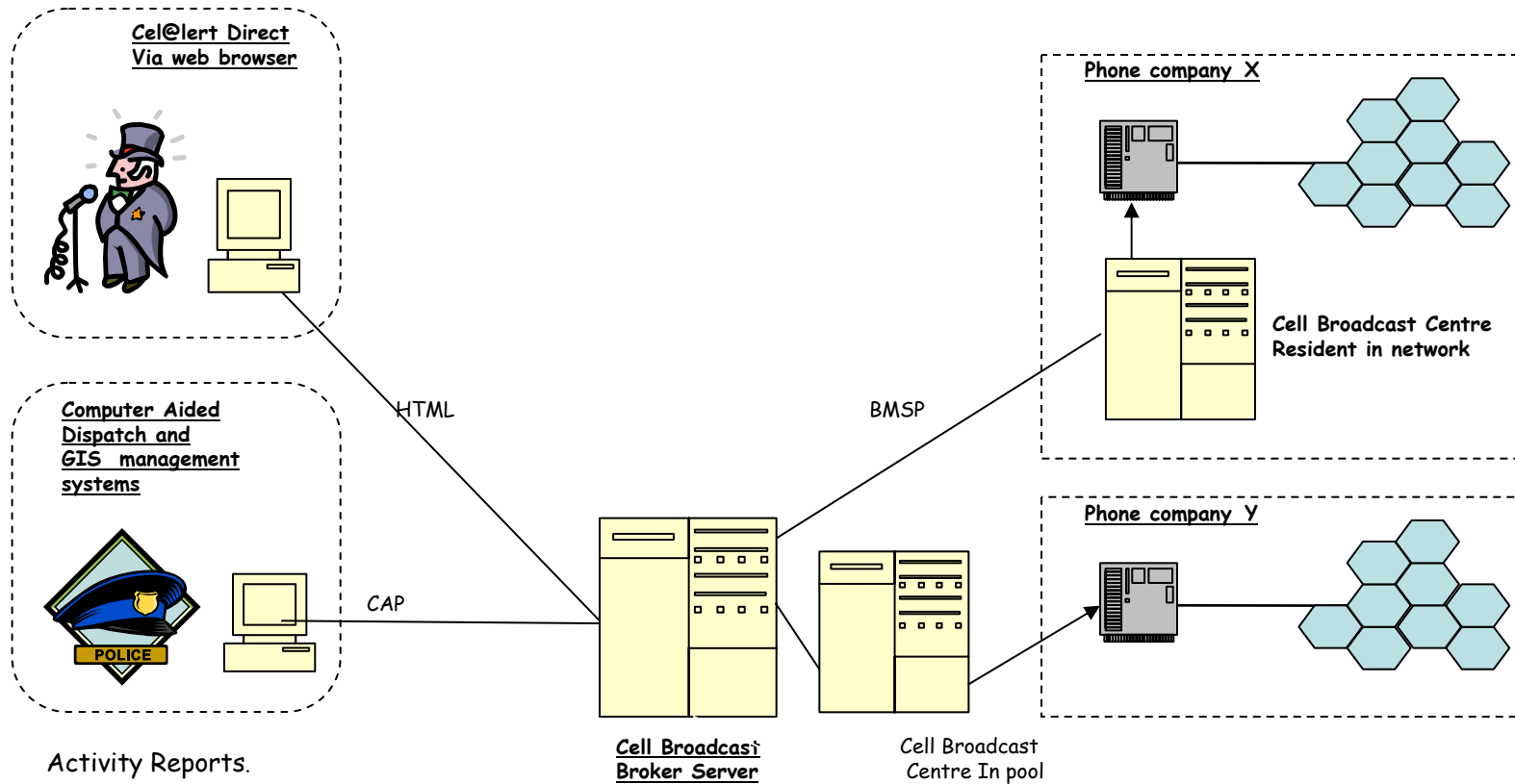

Cell@lert system Components

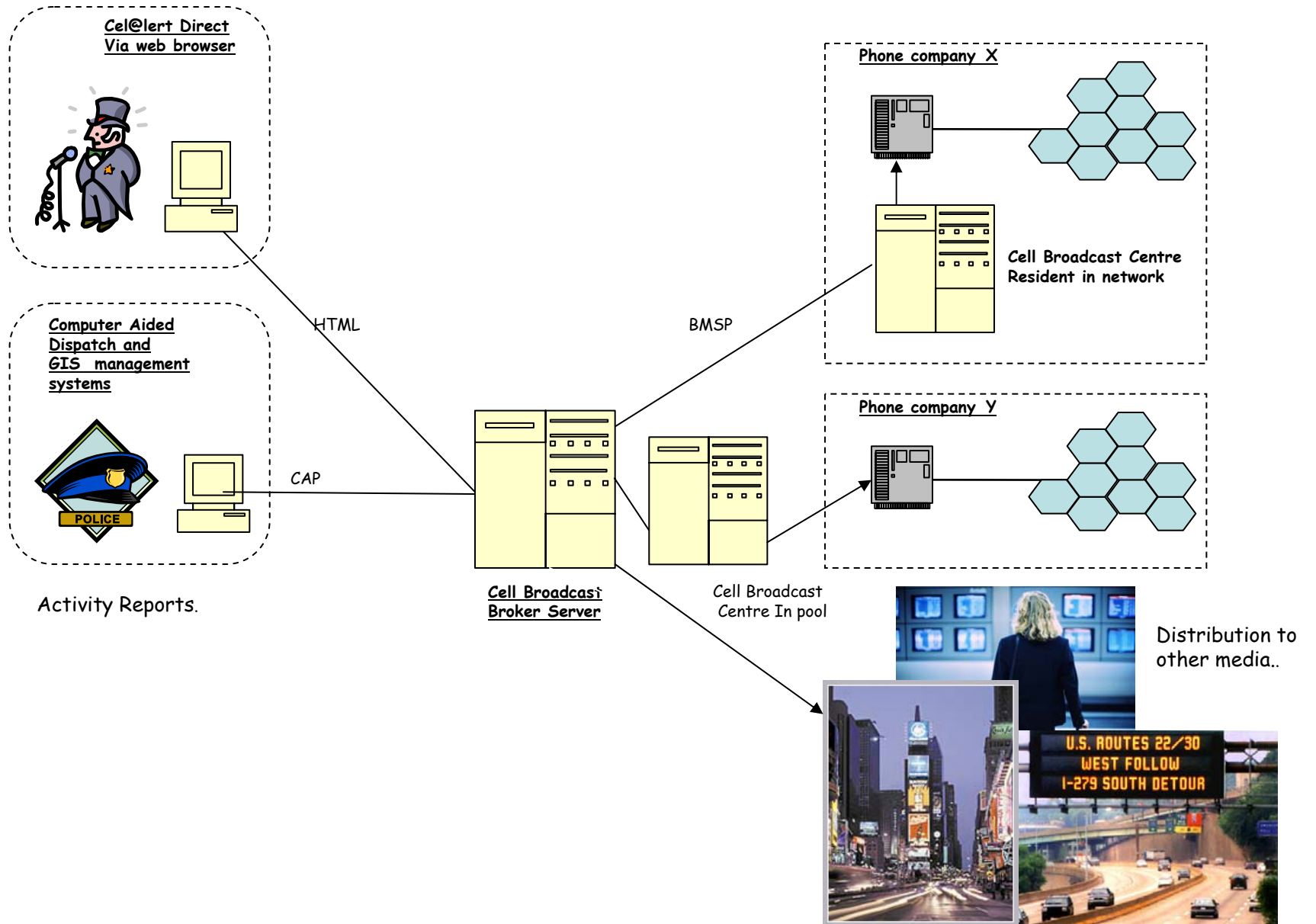

Cell@lert system Components

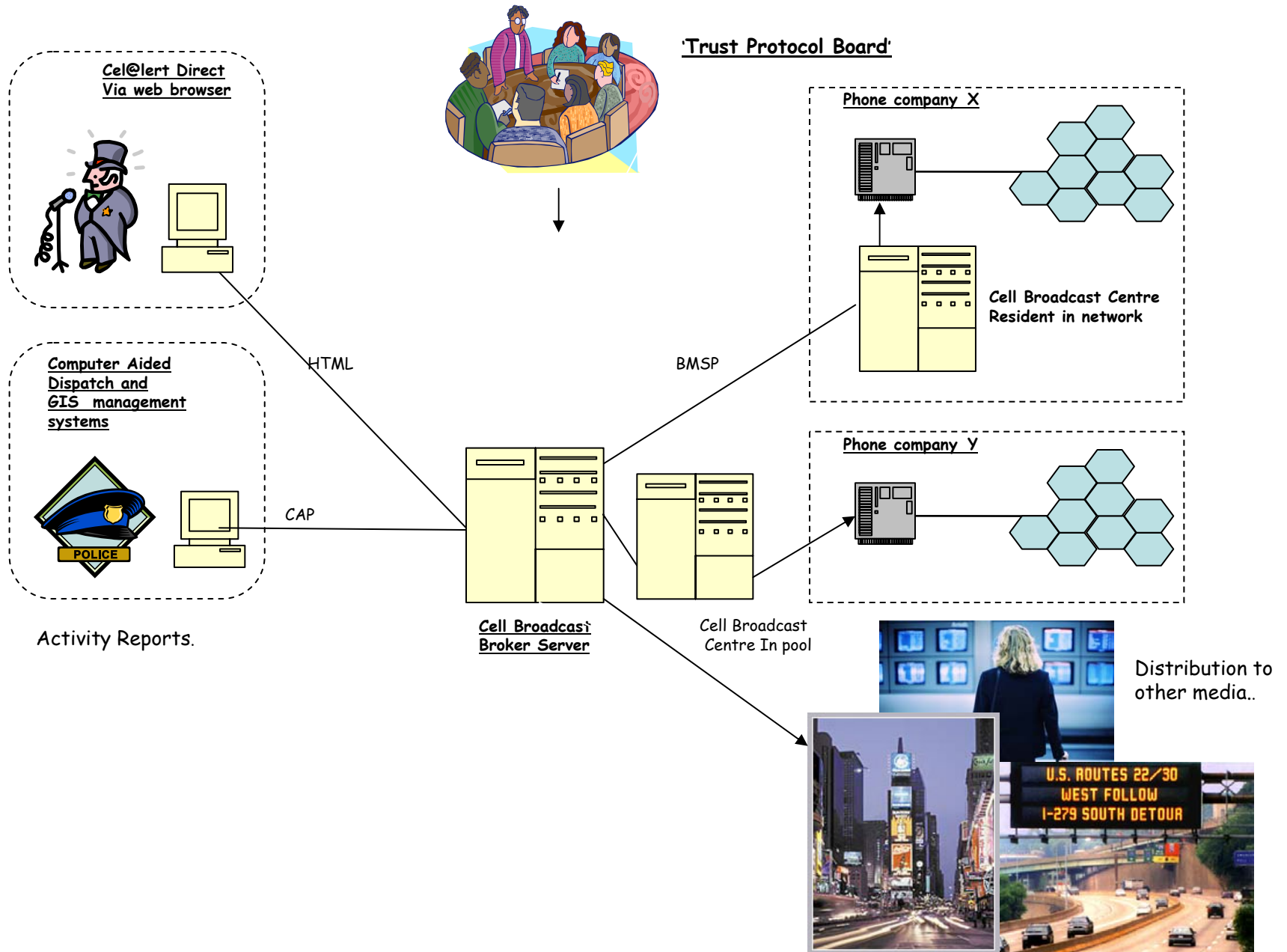

Cell@lert system Components

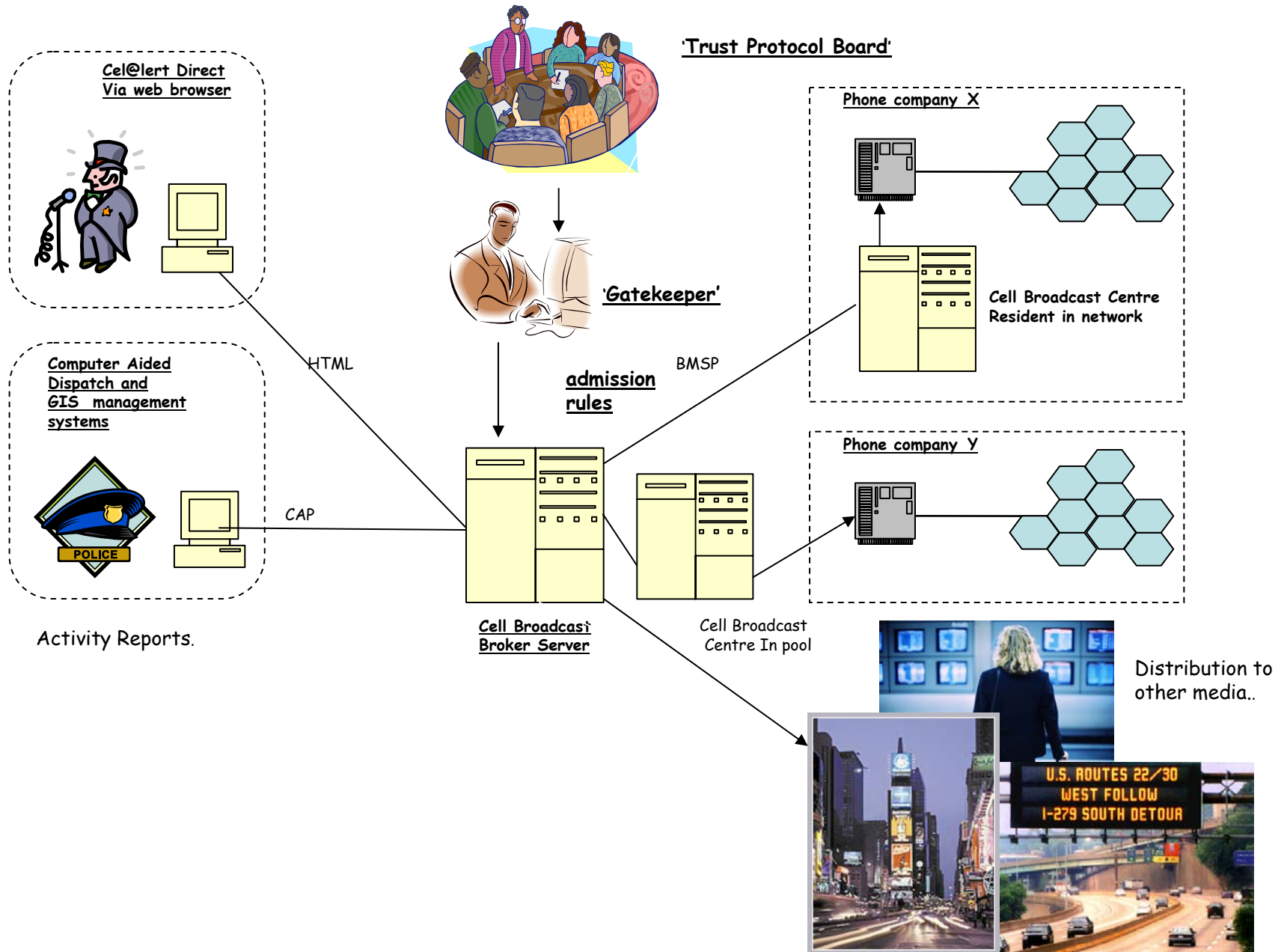

Cell@lert system Components

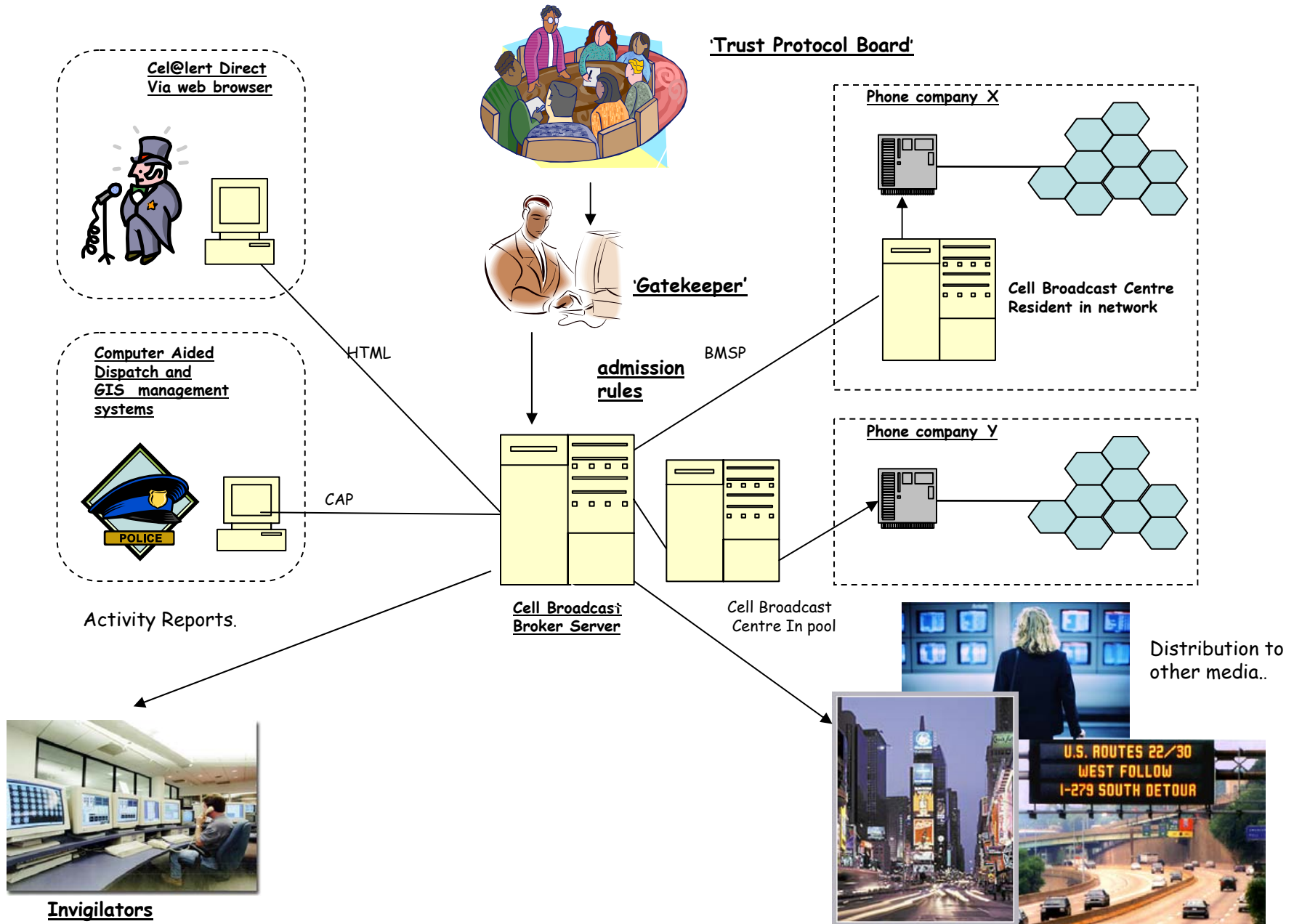

Cell@lert system Components

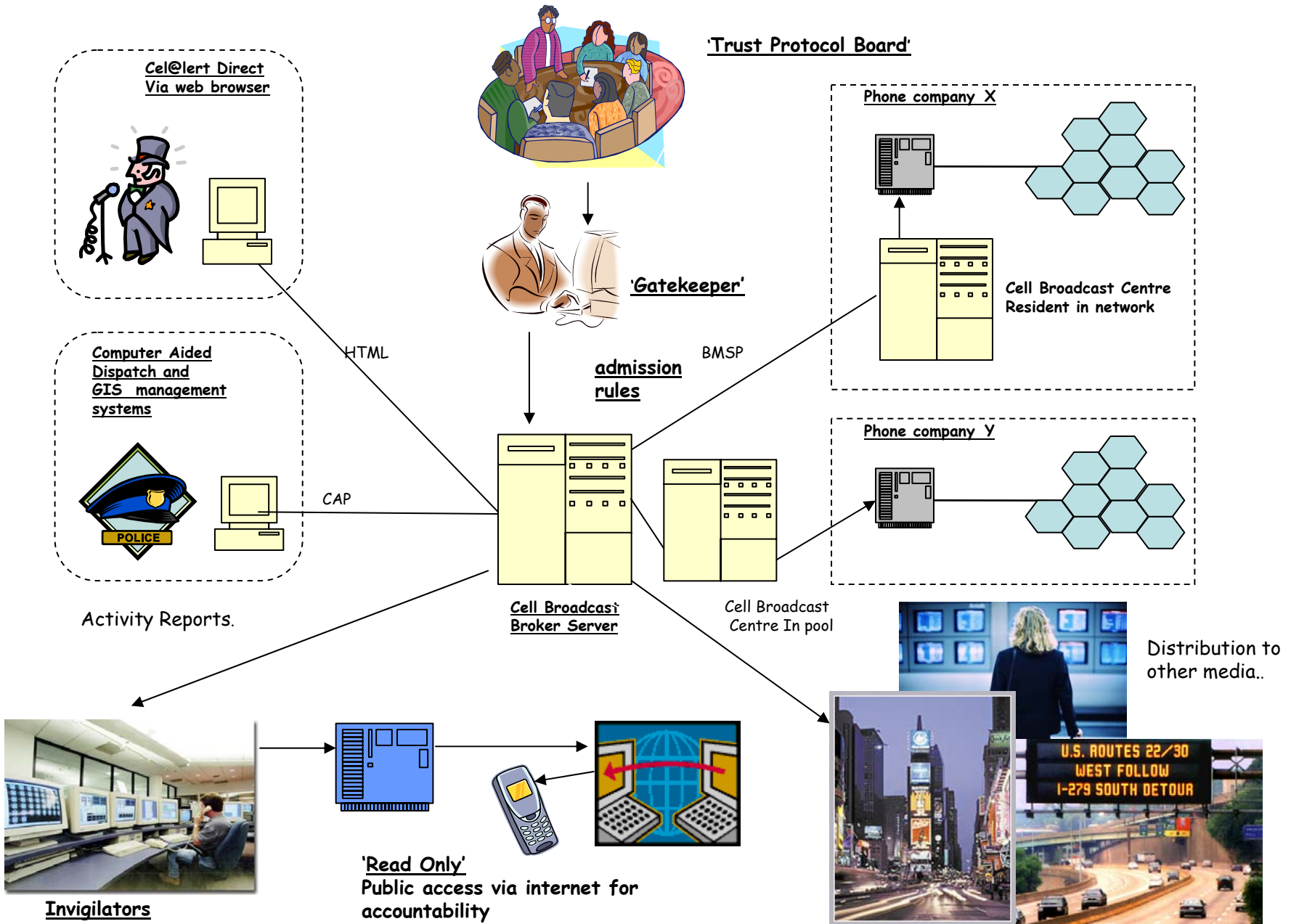

'Cell@lert' System

By

CEASa.

The End



CellAlert

Mark.wood@ceasa-int.org