

ITU-T / ATIS Workshop

“Next Generation Technology and Standardization”

Las Vegas, 19-20 March 2006

Ethernet OAM and Protection Switching

Hiroshi Ohta

Senior Research Engineer, NTT



Why Ethernet became popular among carriers?

- o Reduced equipment costs
- o Ethernet as a universal interfacing technology
- o Can carry any protocol other than IP
- o Recent improvement of bridges
 - High-speed IF (1G, 10G)
 - Long distance IF (-40km)
 - Advanced access capabilities (EFM)
 - More scalable bridges (802.1ad)
- o ... however, OAM capability was limited.



What is OAM (Operation and Maintenance) functions?

- o OAM functions include:
 - Defect detection
 - Defect information notification
 - Defect localization/isolation
 - System protection
 - Performance management
- o ... without these capabilities, it is almost impossible to provide "carrier-class" services
- o OAM is a "must" for carriers

Recent standardization status

- o ITU-T SG13 consented in Jan. 2006 meeting:
 - Y.1731 (Ethernet OAM)
- o ITU-T SG15 consented in Feb. 2006 meeting:
 - G.8031 (Ethernet protection)
 - G.8010 amendment 1 (Ethernet architecture)
 - G.8021 amendment 1 (Ethernet equipment)
- o IEEE 802.1ag (CFM):
 - Draft 5.2, next TG ballot will be conducted soon

Y.1731 (Ethernet OAM mechanisms) - 1

- o Y.1731 is a superset of IEEE 802.1ag
- o Both Y.1731 and IEEE 802.1ag specify
 - CC (Continuity Check): loss of connectivity defect detection
 - LB (Loopback): defect localization
 - LT (Link Trace): verification of network configuration
 - AIS (Alarm Indication Signal): alarm suppression

Y.1731 (Ethernet OAM mechanisms) - 2

- o Y.1731 also specifies:
 - Fault management
 - Test: throughput, frame loss and bit error measurement
 - LCK (Locked): indication of service unavailability due to maintenance activities
 - MCC (Maintenance Communication Channel)
 - EXP (Experimental OAM)
 - VSP (Vendor Specific OAM)
 - Performance management
 - LM (Loss measurement): frame loss measurement
 - DM (Delay measurement): frame delay measurement



Y.1731 vs. IEEE 802.1ag

- o Same specifications (although the ways of description are different)
 - CC, LB, LT, AIS
- o OAM frame is identified by a specific EtherType. IEEE 802.1ag specifies this value.
- o Each OAM function is identified by the value of the "OpCode" field.
 - 32 code points are reserved for IEEE 802.1ag
 - Other 32 code points for ITU-T.

OAM mechanisms

MEG levels

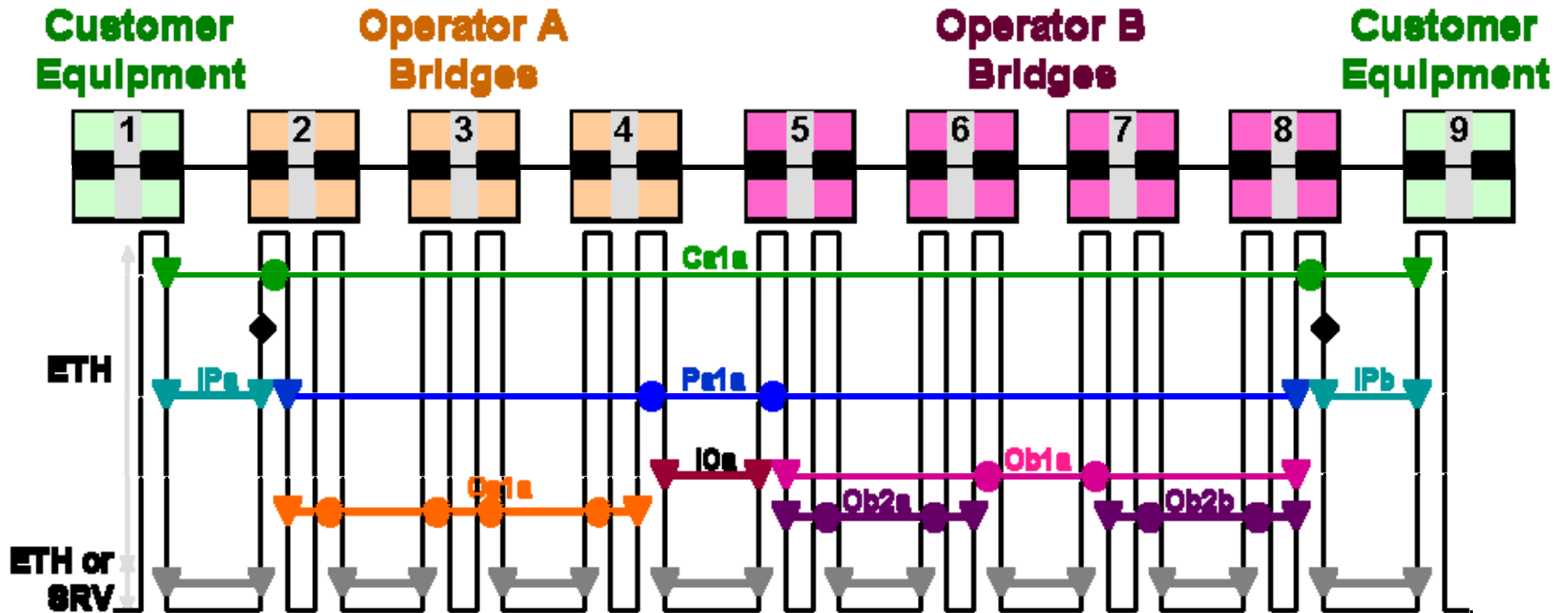

Multiple MEG levels are defined to allow running OAM in different spans

CC (Continuity Check) - 1

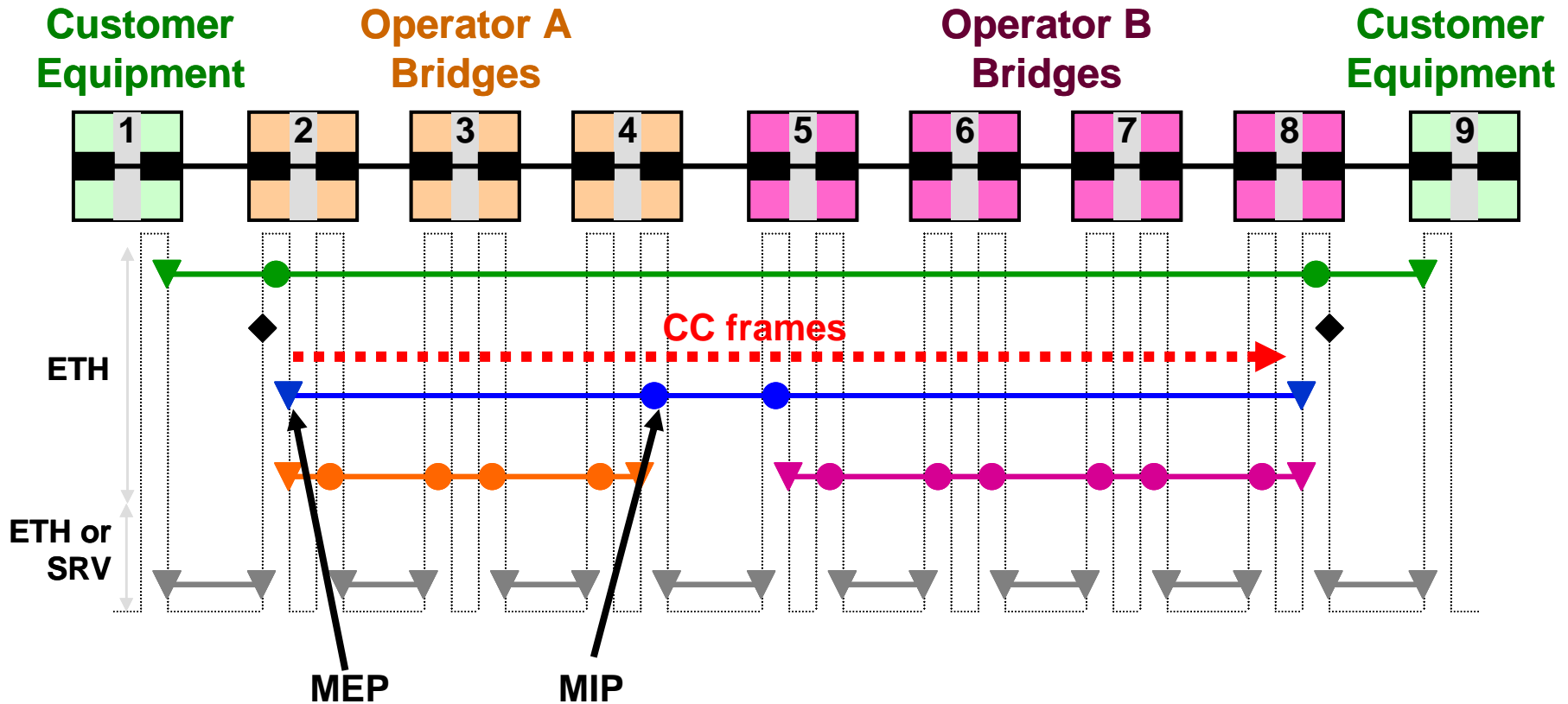

- MEP transmits CC frames periodically.
- If a MEP does not receive any CC frames for 3.5 times of the CC frame transmission interval, it declares an alarm (loss of connectivity)

CC (Continuity Check) - 2

Each MEP sends CC frames to all other MEPs

Each receiving MEP detects loss of CC frames and unexpected CC frames

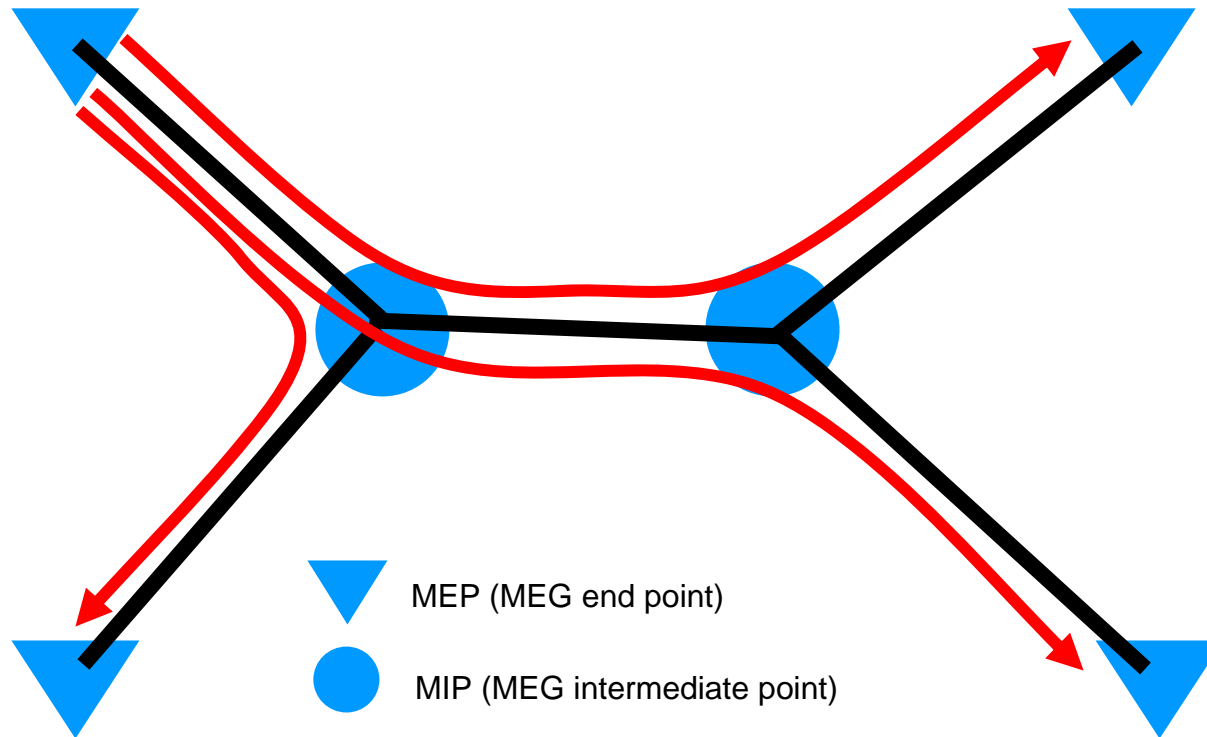

CC can be used for defect detection in multipoint-to-multipoint networks.

LB (Loopback)

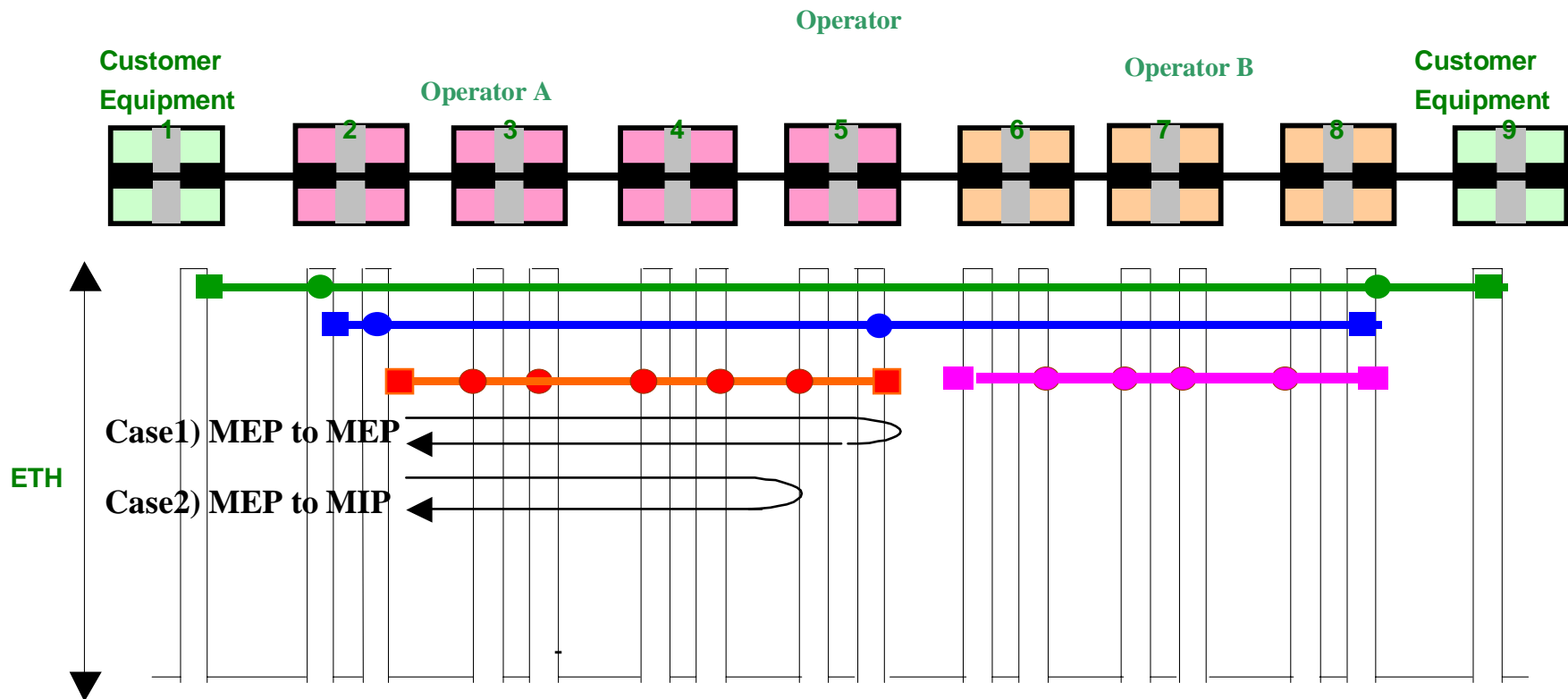

LB is mainly used for connectivity verification changing the test span.

LT (Link Trace)

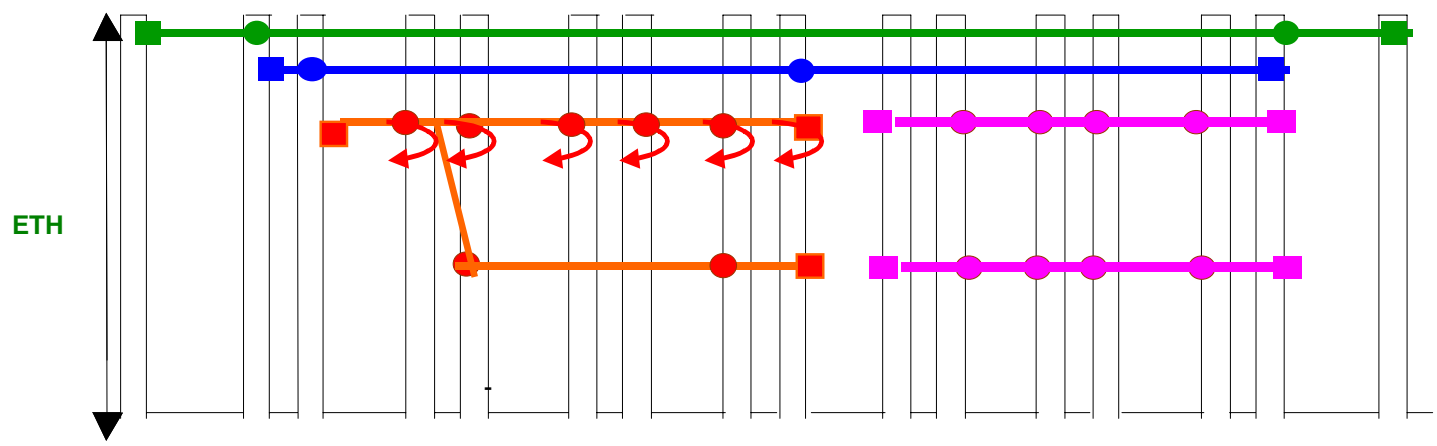
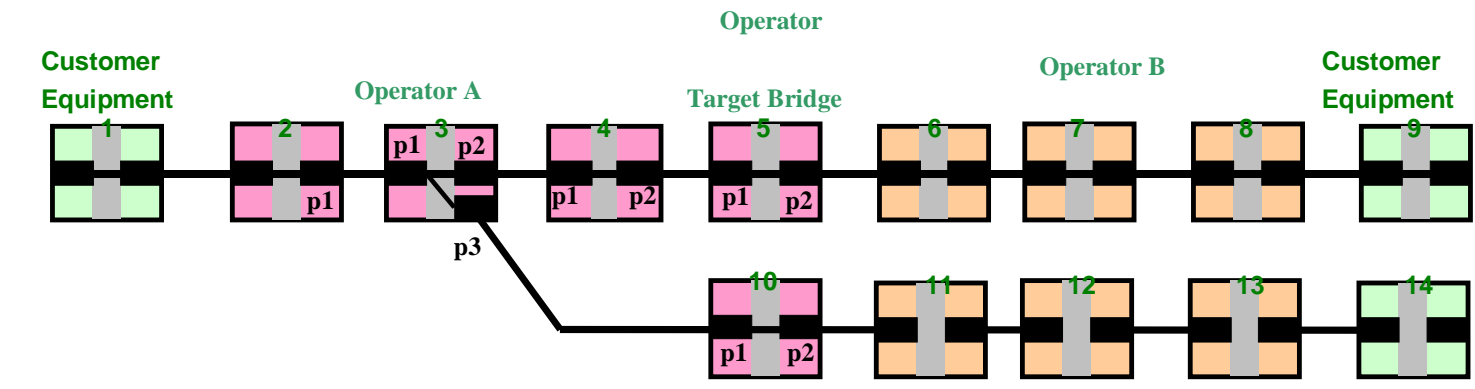

LT is mainly used for verifying the network configuration.



AIS (Alarm Indication Signal)

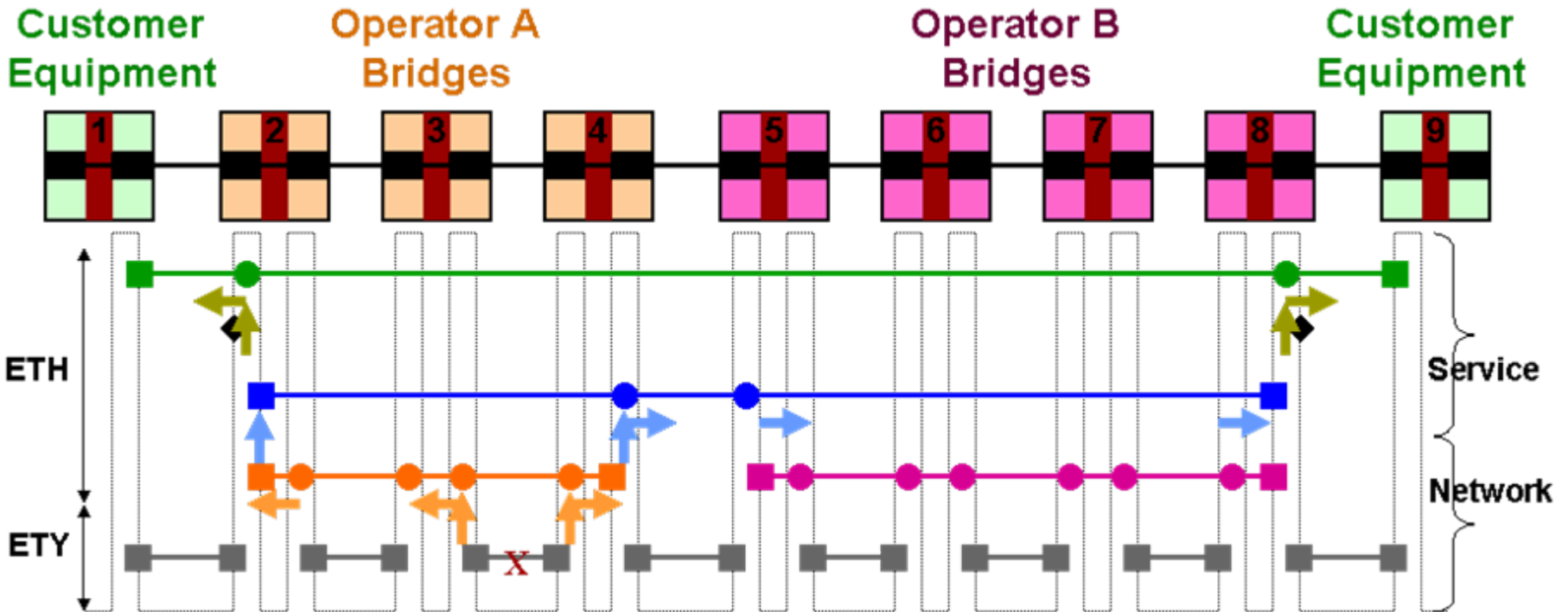

AIS is used for alarm suppression by notifying the bridges in downstream of the existence of the defect and of the fact that it has already been reported (and as such, bridges in downstream need to take no action).

G.8031 (Ethernet protection switching)

- Defines bidirectional 1+1/1:1 and unidirectional 1+1 protection switching.
- This version covers point-to-point protection switching only.

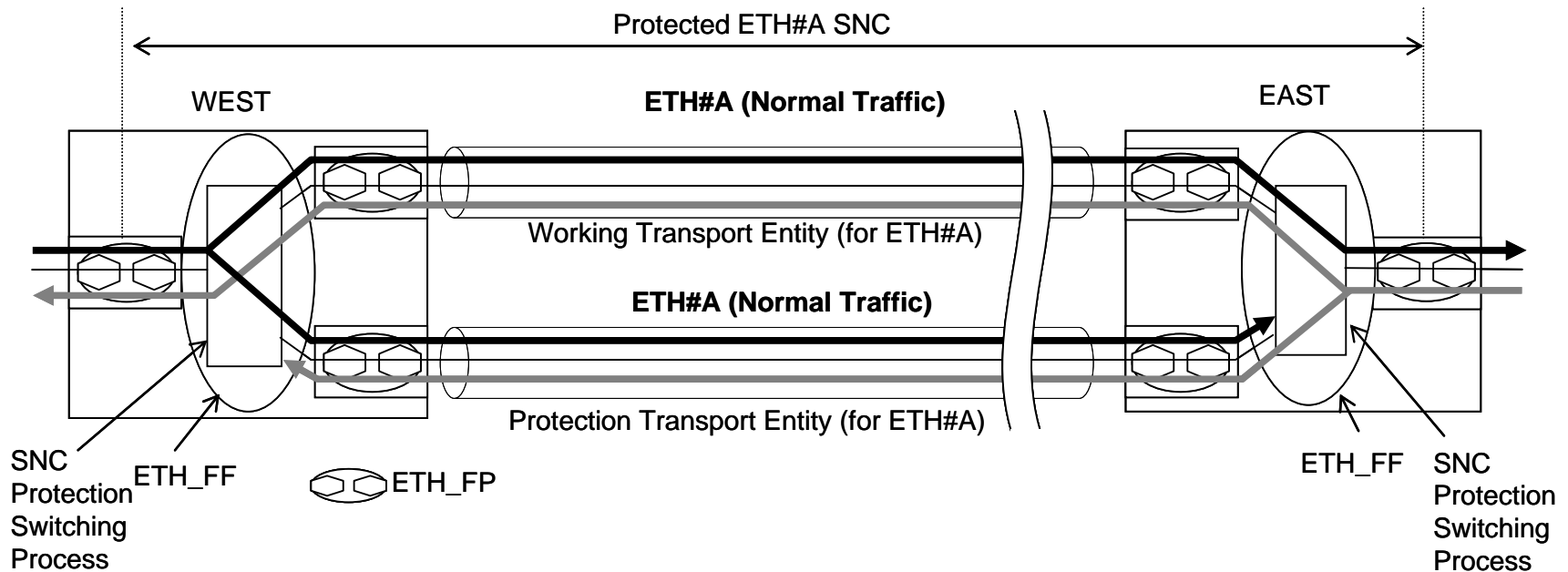

1:1 bidirectional protection switching architecture

Conclusion

- o Ethernet is now widely used by carriers.
- o Its OAM capabilities were limited but ITU-T consented Ethernet OAM and other related Draft Recommendations recently.
- o Recommendations on Ethernet architecture, Ethernet equipment and Ethernet services are also under work. These standards are expected to become available soon.
- o These Ethernet-related standards enhance advantages and attractiveness of Ethernet as **a transport technology for NGN**.