



International Telecommunication Union

NGN Business Models

Chae Sub Lee

Vice-Chairman of ITU-T SG13



Contents

1. Why need Next Generation?
2. Key trends in Telecommunications
3. Impacts of NGN
4. NGN Configurations and Players
5. Utilization of NGN
6. Conclusion



1. Why need Next Generation?

Success, Problems or Dilemmas?

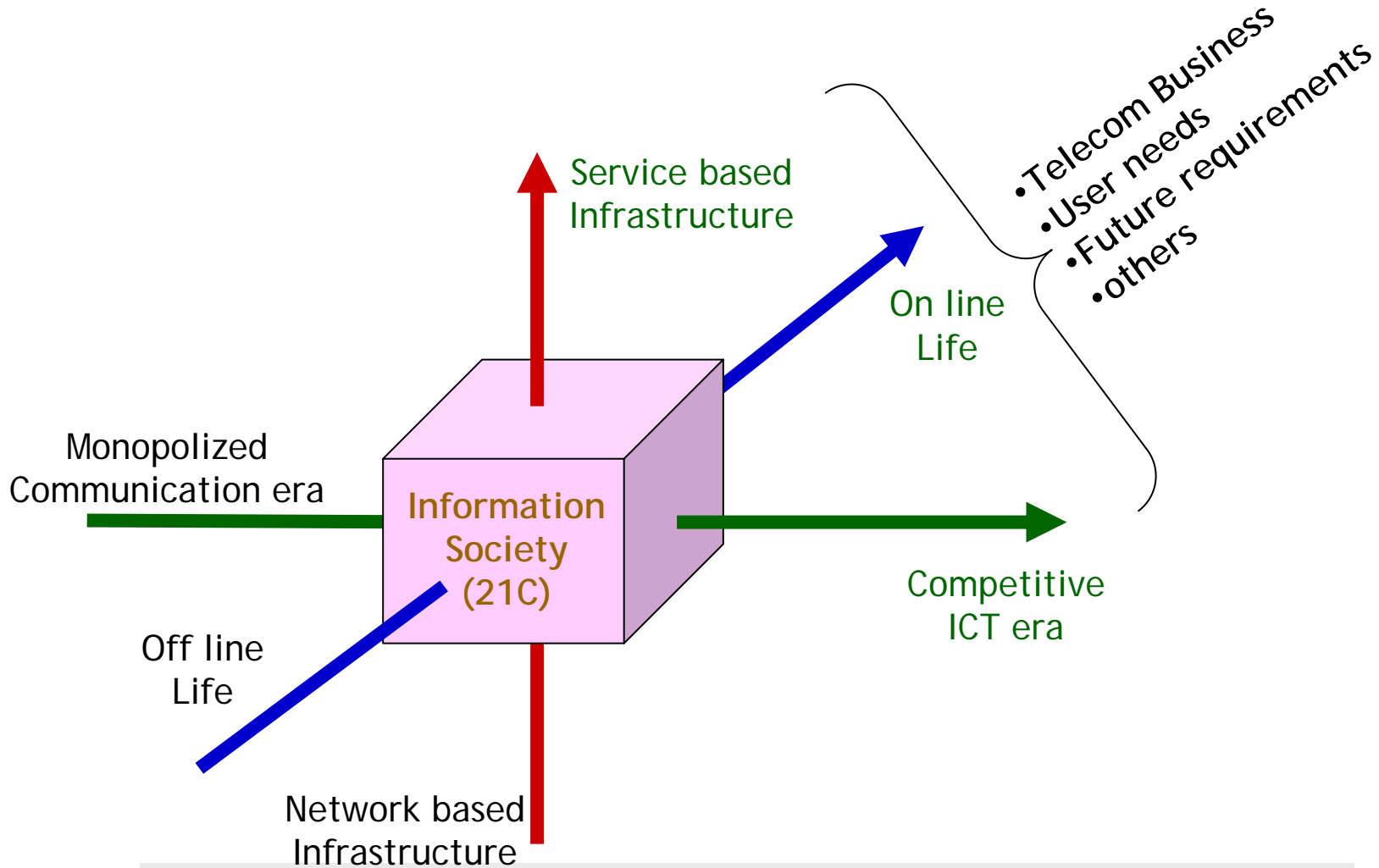



1. Why need Next Generation?

Telecom Market Today

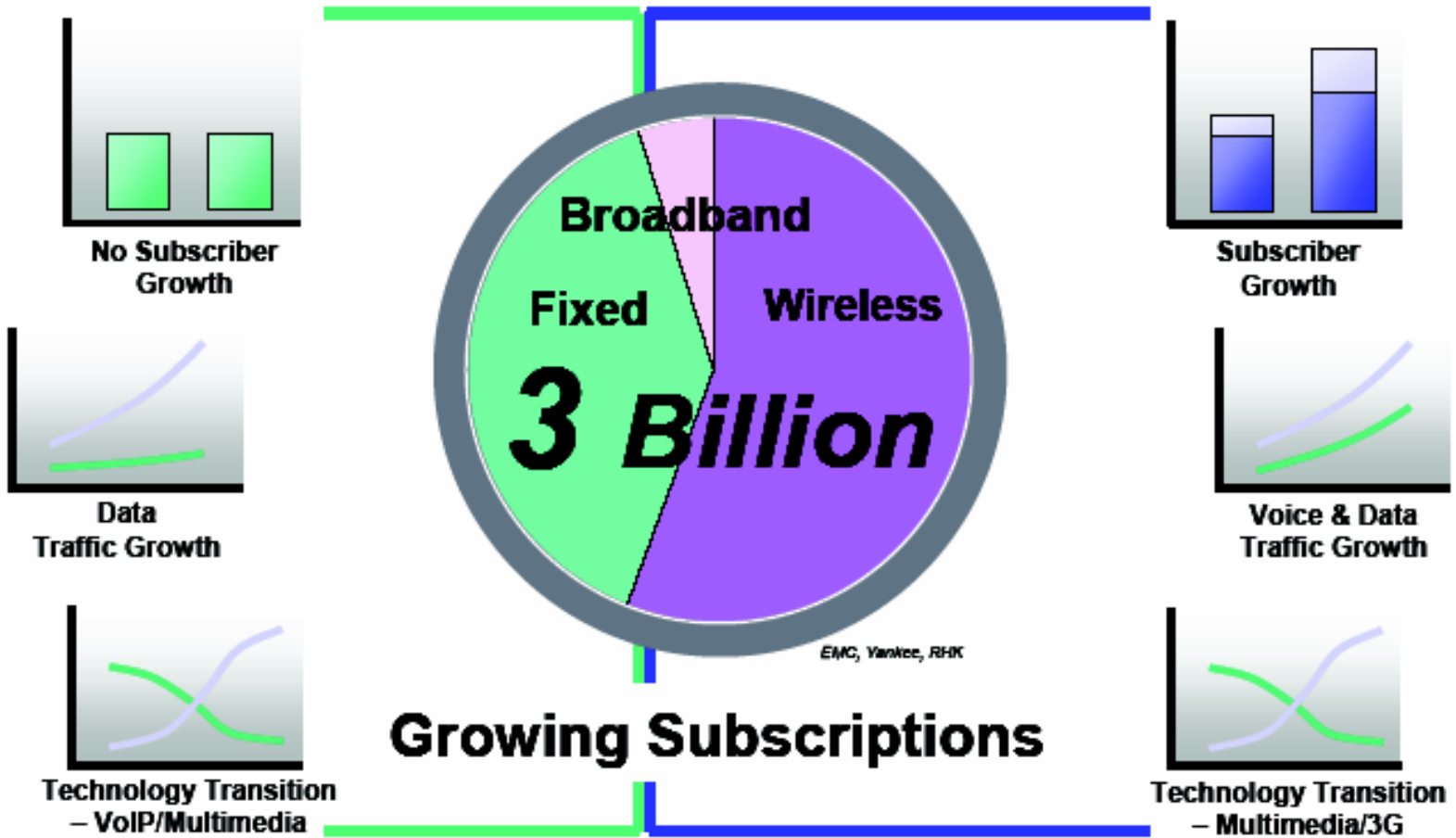

*Source : "Mobility and Fixed Mobile Convergence, John Visser, Nortel, ITU-T/ATIS NGN Workshop, Las Vegas, USA, March.2006



1. Why need Next Generation?

What is keeping SP CEOs awake at night?

- Revenue is saturated or declining for most core products
- Competition is increasing in all markets
- Google, Skype et al are creating a new kind of competitive landscape → **Venice Project**
- Costs are too high
- We need a solution NOW

*Source : "NGN: an answer to all end users' problems?", Chris Lewis, NGN Industry Event, London, UK 11.2005



1. Why need Next Generation?

But even Mobile Business...

ARPU of SK Telecom in Korea

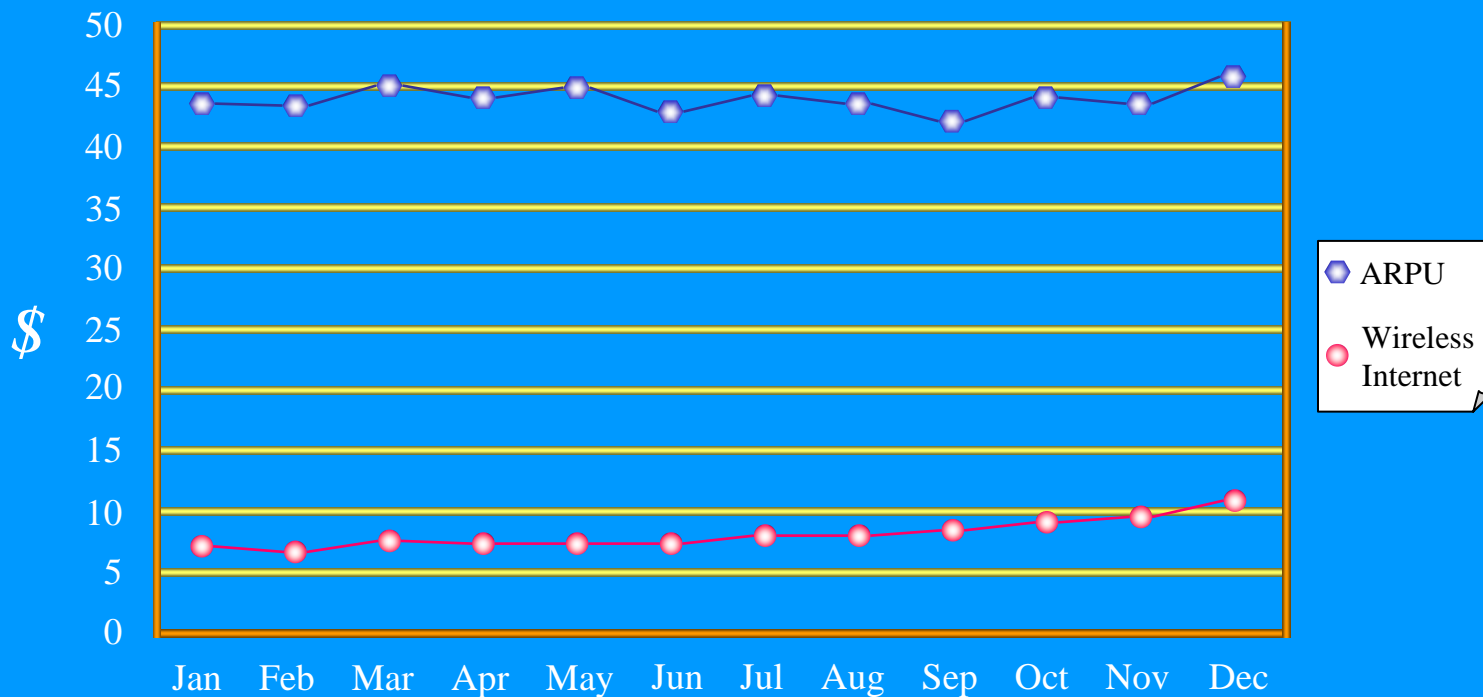

Source: SK telecom



1. Why need Next Generation?

ARPU Analysis

- o Analysis means
 - Subscribers saturated in Korea
 - ARPU increases little and slightly
 - Voice revenue keeps stagnant
 - Wireless data revenue has jumped three fold over the past three years
 - But ARPU doesn't increase that much because of price reduction



1. Why need Next Generation?

No clear reason, but want.....

What is the main benefit of FMC for telecom service providers?

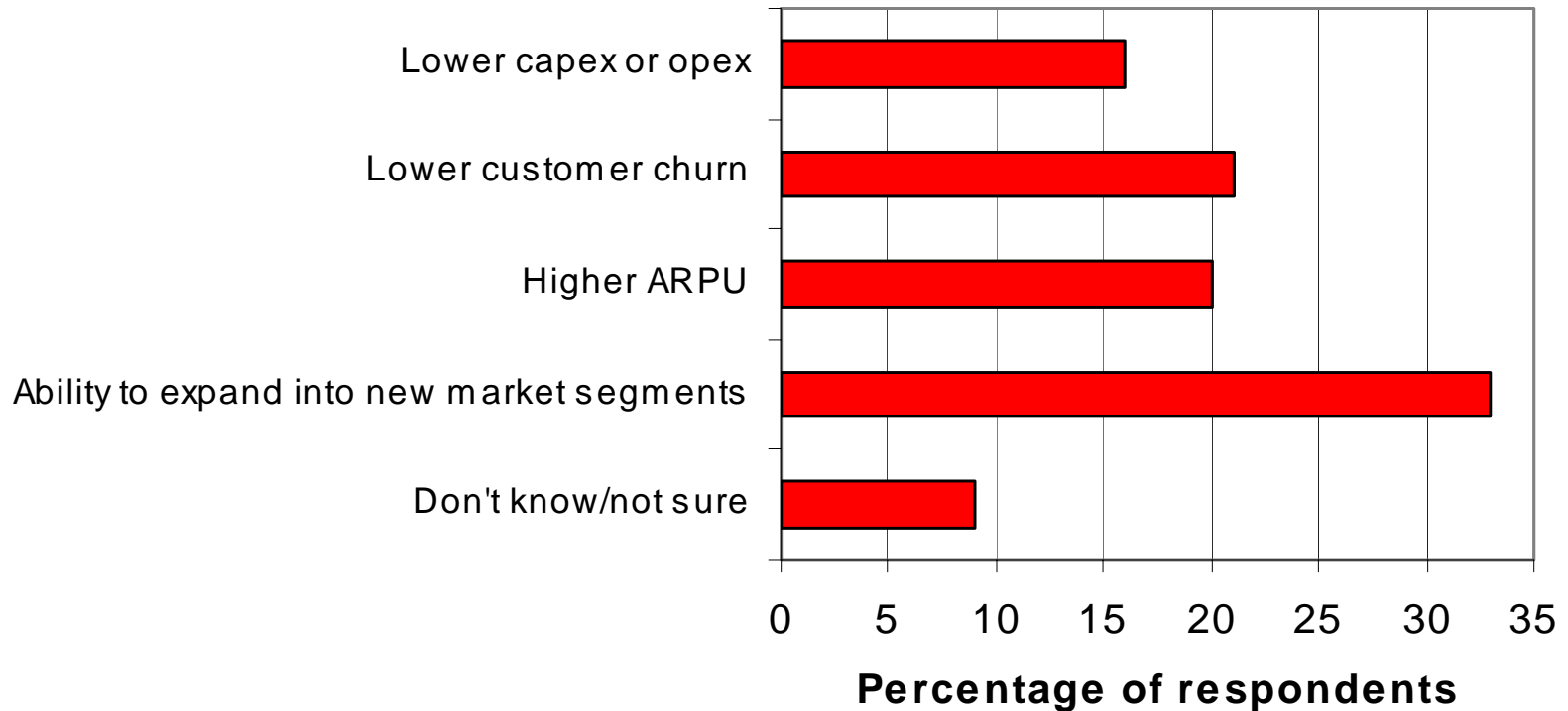

*Source : "NGN, IMS and FMC", Graham Finie, NGN Industry Event, London, UK 11.2005



1. Why need Next Generation?

Everybody needs next, so... NGN



Integrated Engineering



Moves, adds and changes

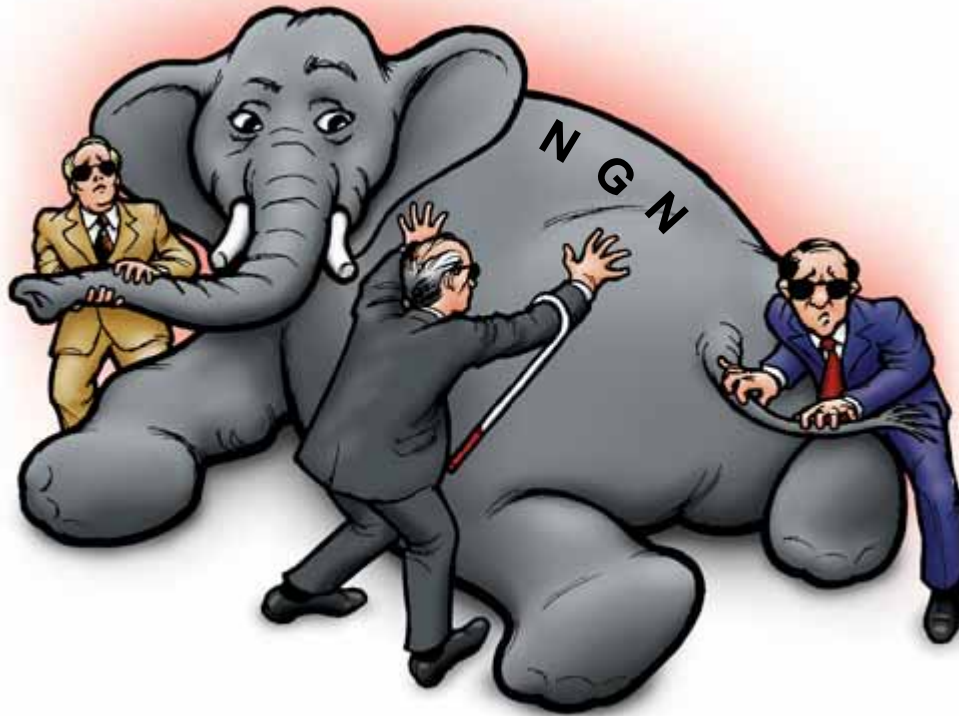

Mobile Workers



Intelligent Office



Teleworking

*Source : "NGN: an answer to all end users' problems?", Chris Lewis, NGN Industry Event, London, UK 11.2005



2. Key trends in Telecommunications

Packet based Environments

Past : Seper. of Voice & Data Transp.

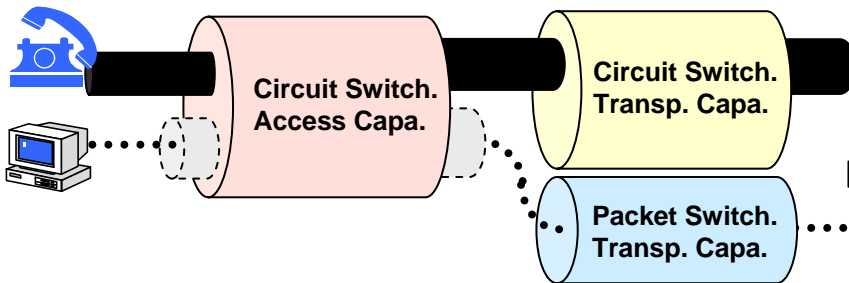

Present : Sep. of V & D Access

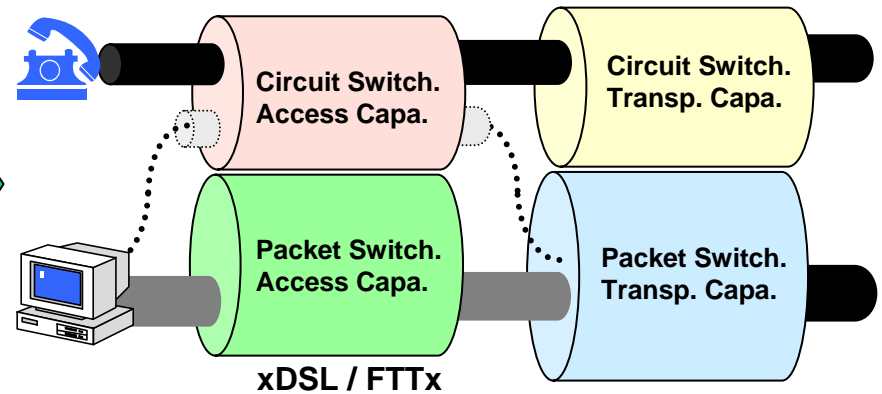

Future : Integration of V & D Access and Transp.

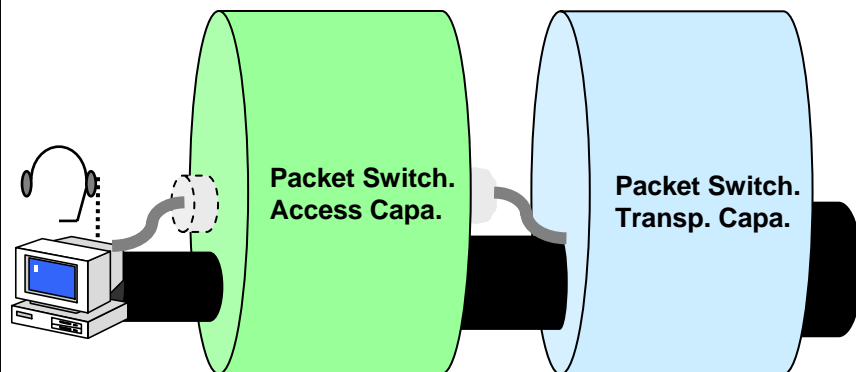

Near Future : Integration of V & D Transport

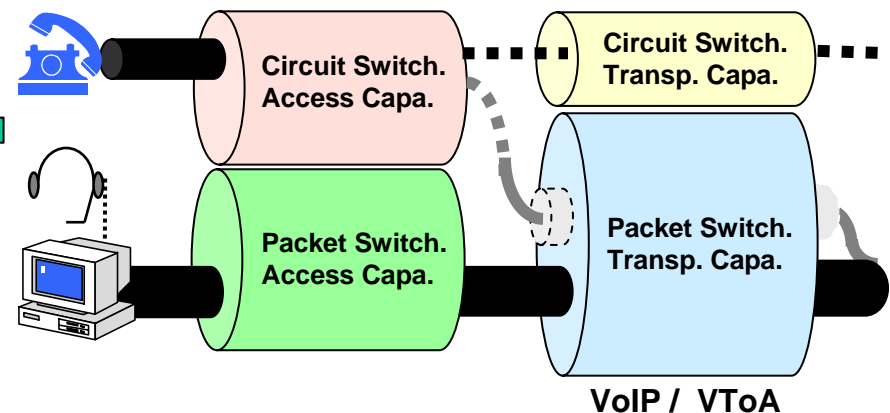



Converged User Terminals

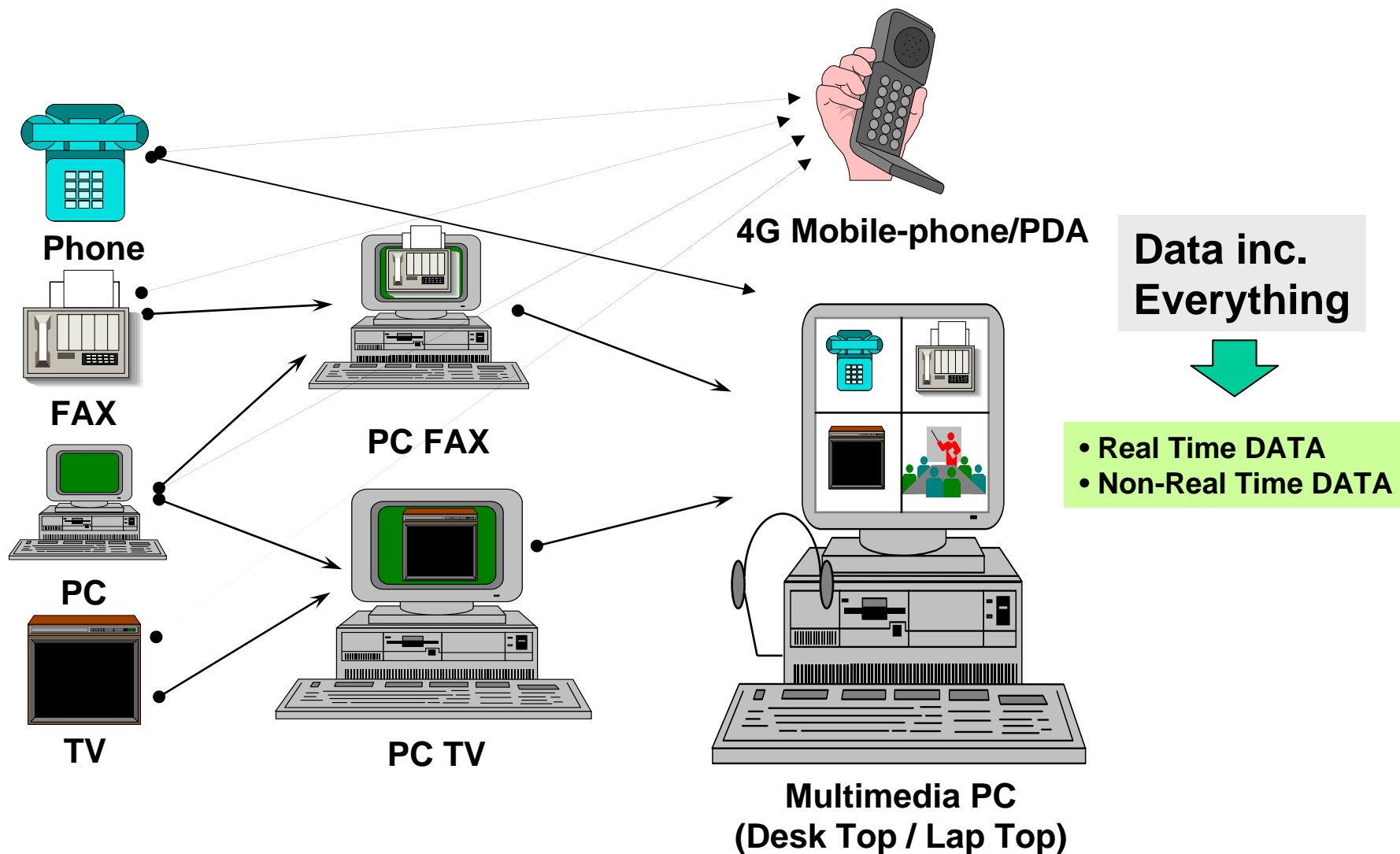



2. Key trends in Telecommunications

Competition in Enterprises

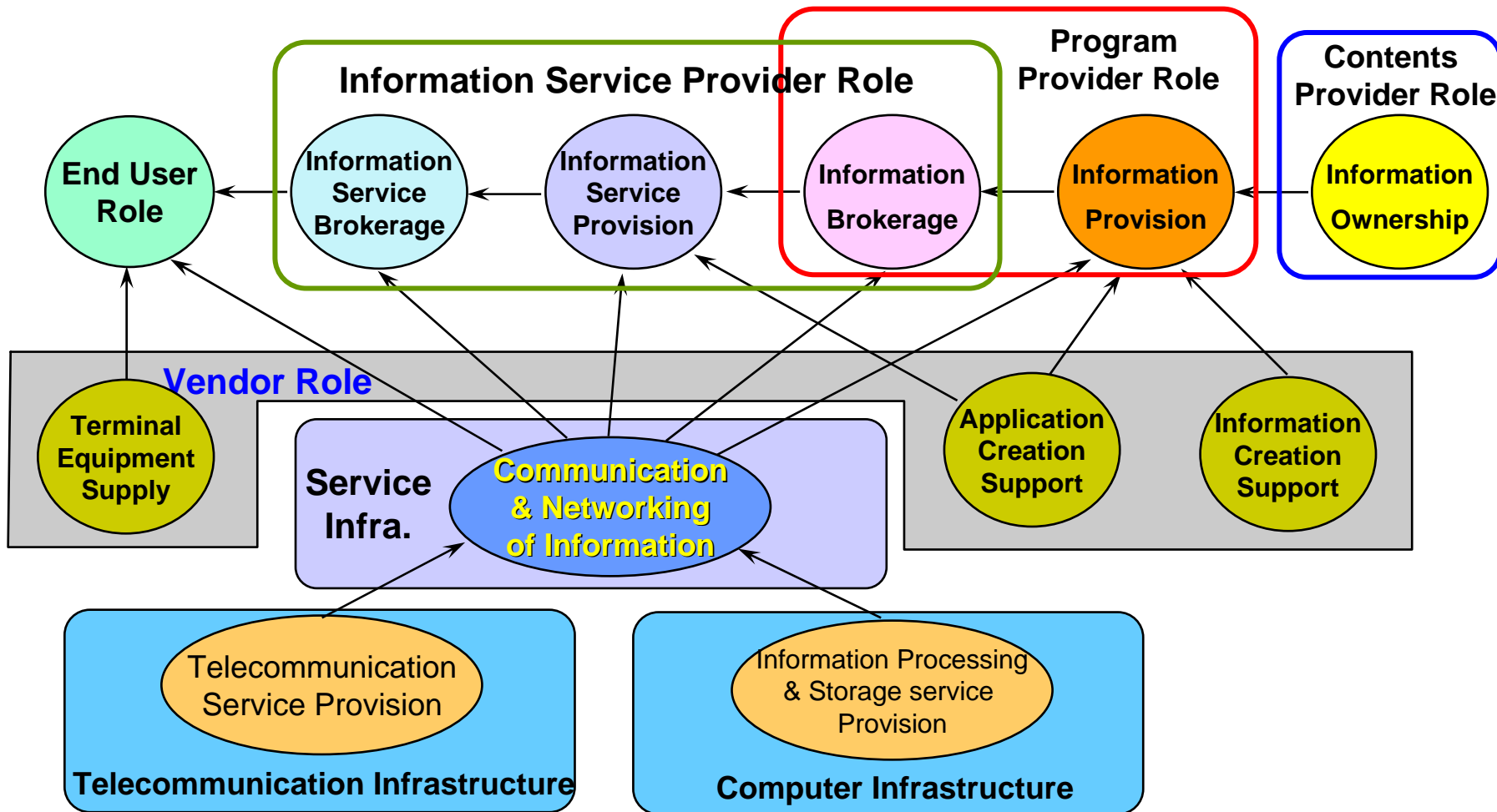

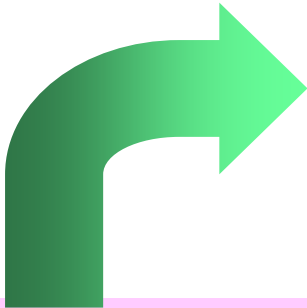

NGN in 4 words...

- 
- by Fixed
 - by Mobile
 - by Wireless

NGN = Broadband Managed IP Network

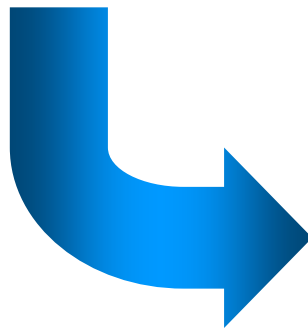
- 
- for Services
 - for Businesses
 - for Players
 - for Users



Key Principles of NGN

- Open architecture: open to support service creation, service updating, and incorporation of service logic provision by third parties and also support “Distributed control” as well as enhanced security and protection.
- Independent provisioning: service provision process should be separated from network operation by using distributed, open control mechanism to promote competition.
- Multiplicity: The NGN functional architecture shall offer the configuration flexibility needed to support multiple access technologies.



3. Impacts of NGN

Competition and Collaboration

Pre-NGN

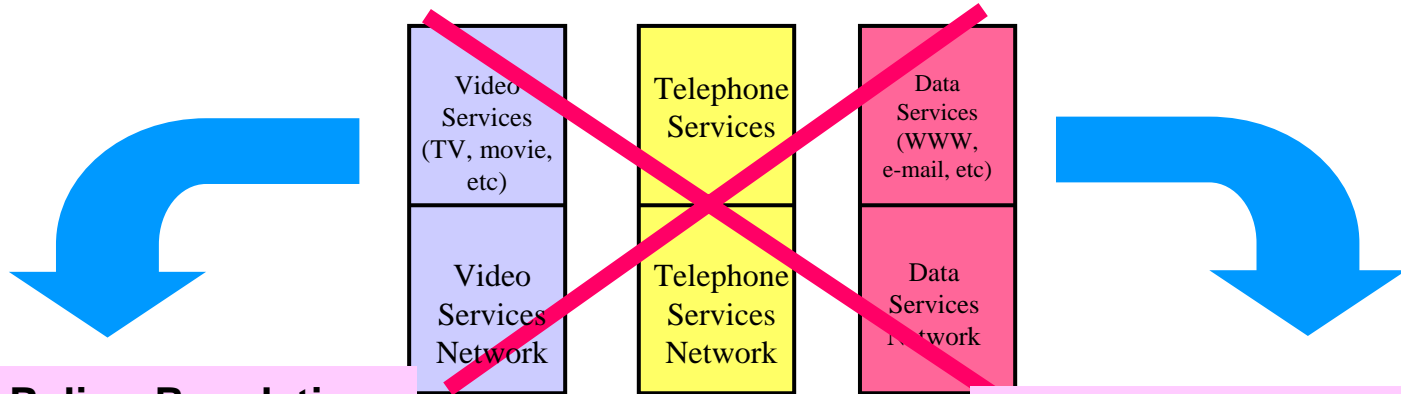

New Policy • Regulation Environment (Horizontal)

New Business Environment (Compositional)

Service-based Pol./Reg.

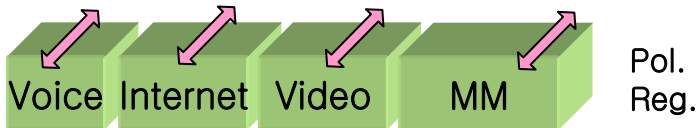

IP (Future Packet ?) Platform Pol. X
Reg. x

xDSL/Optic based Fixed-Mobile

Resource-based Pol./Reg.



Access Network Provider Domain

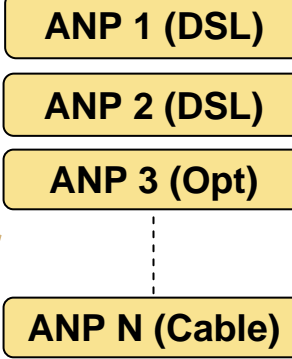

Service/Application Provider Domain

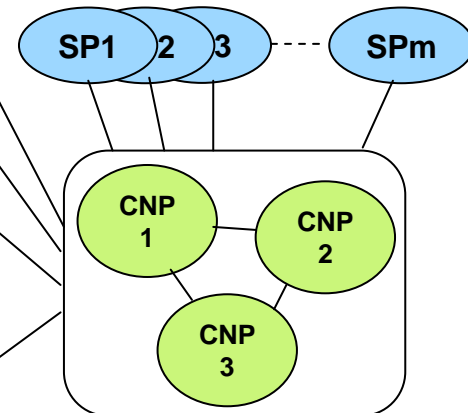

Core Network Provider Domain



Driving Forces from NGN

● Support of New Value Added Services

- Saturation of both Fixed and Mobile telephone services
- Need of Integrated (Fixed+Wireless) and Convergence (Telecom+Broad.)

● Support of New Service Paradigm

- Increase of Service requirements (Flex. of Access, Diversity of Service etc.)
- Increase of High Quality services (Beyond QoS over the Internet)

● Continue growing energy for IT Business

- Preparation of New Revenue Stream based on IT Business
- Development of new high-tech and market



4. NGN configuration and players

Overview on NGN configuration

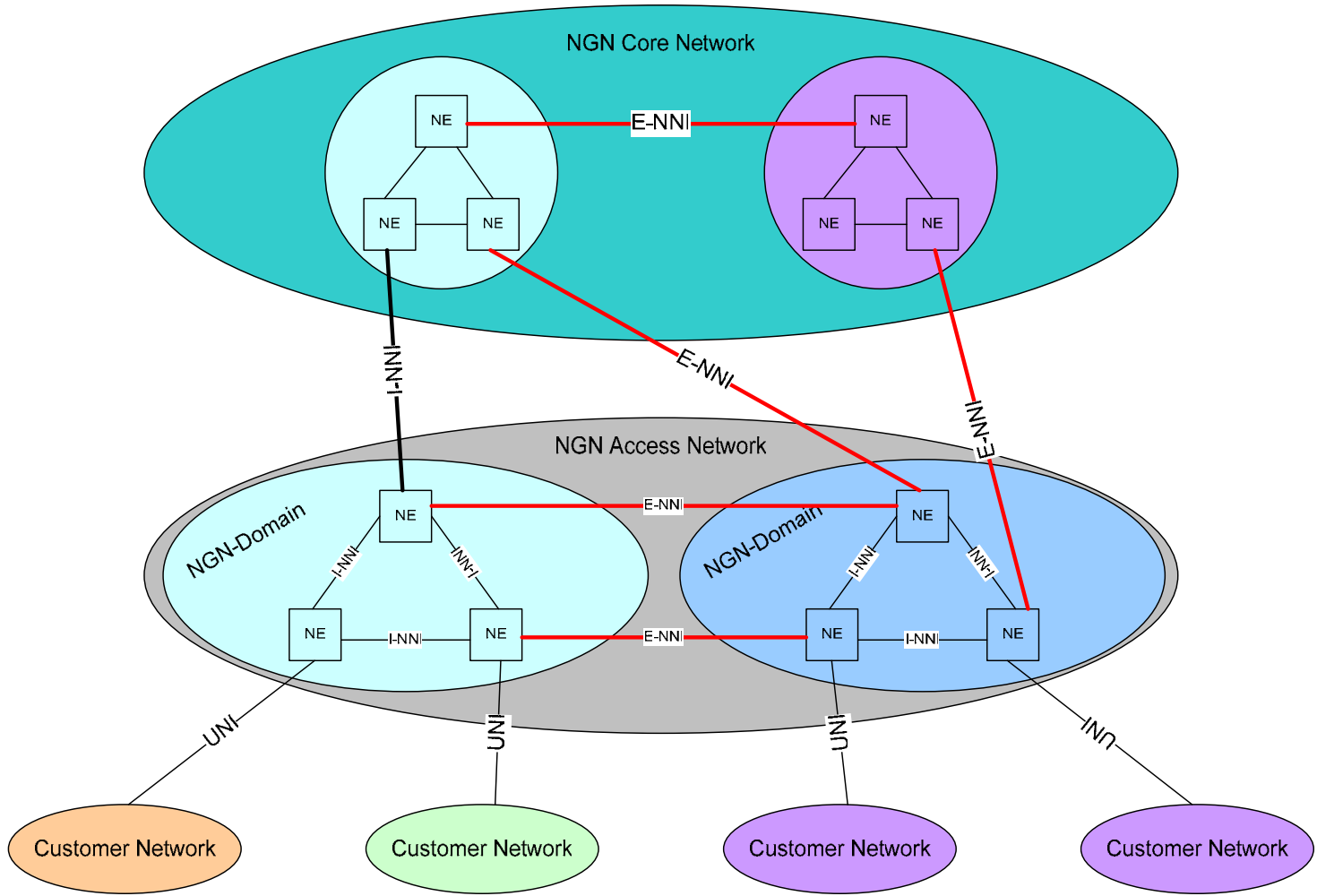



4. NGN configuration and players

Horizontal view of NGN configuration

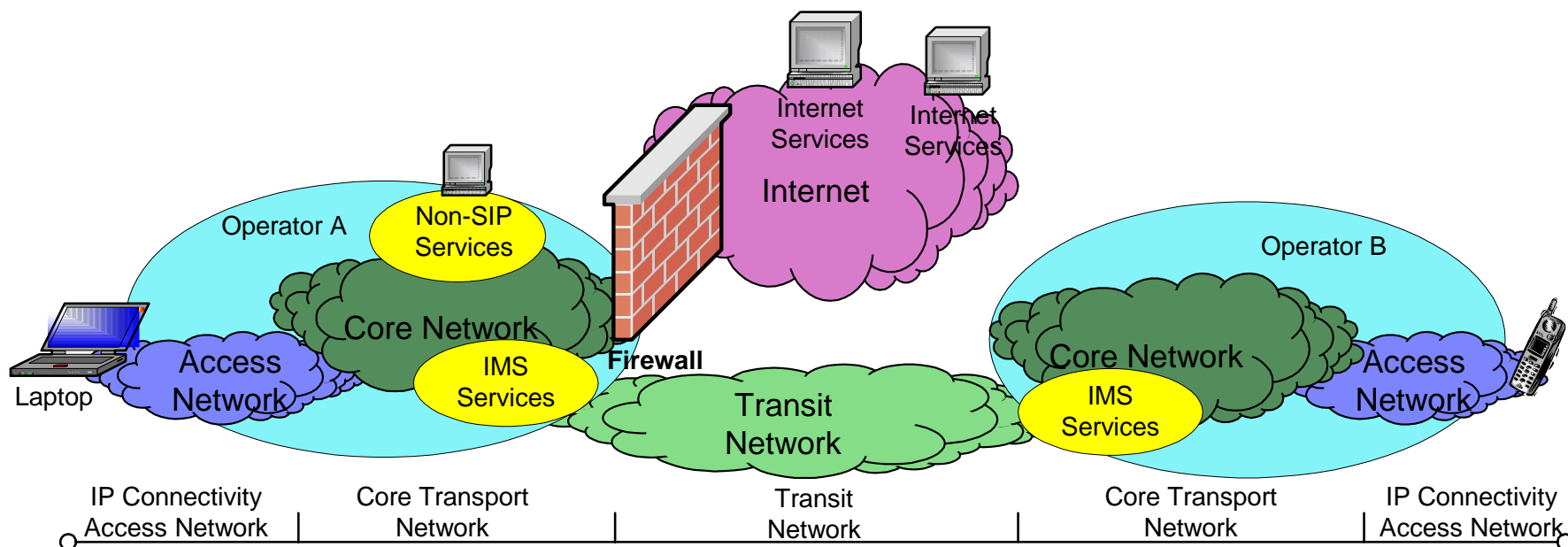



4. NGN configuration and players

Basic NGN Roles and Players

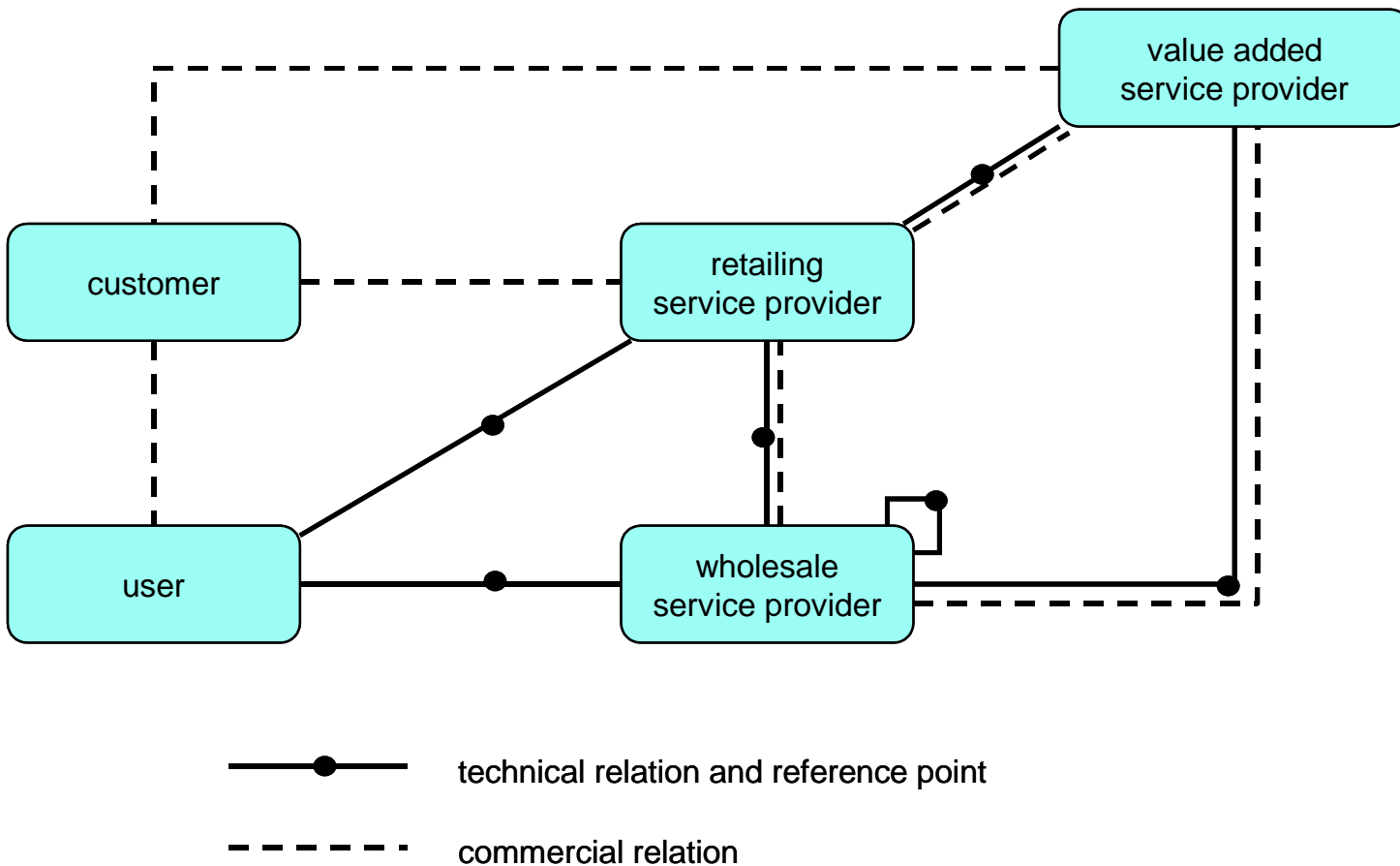



4. NGN configuration and players

NGN roles: First level of specialization

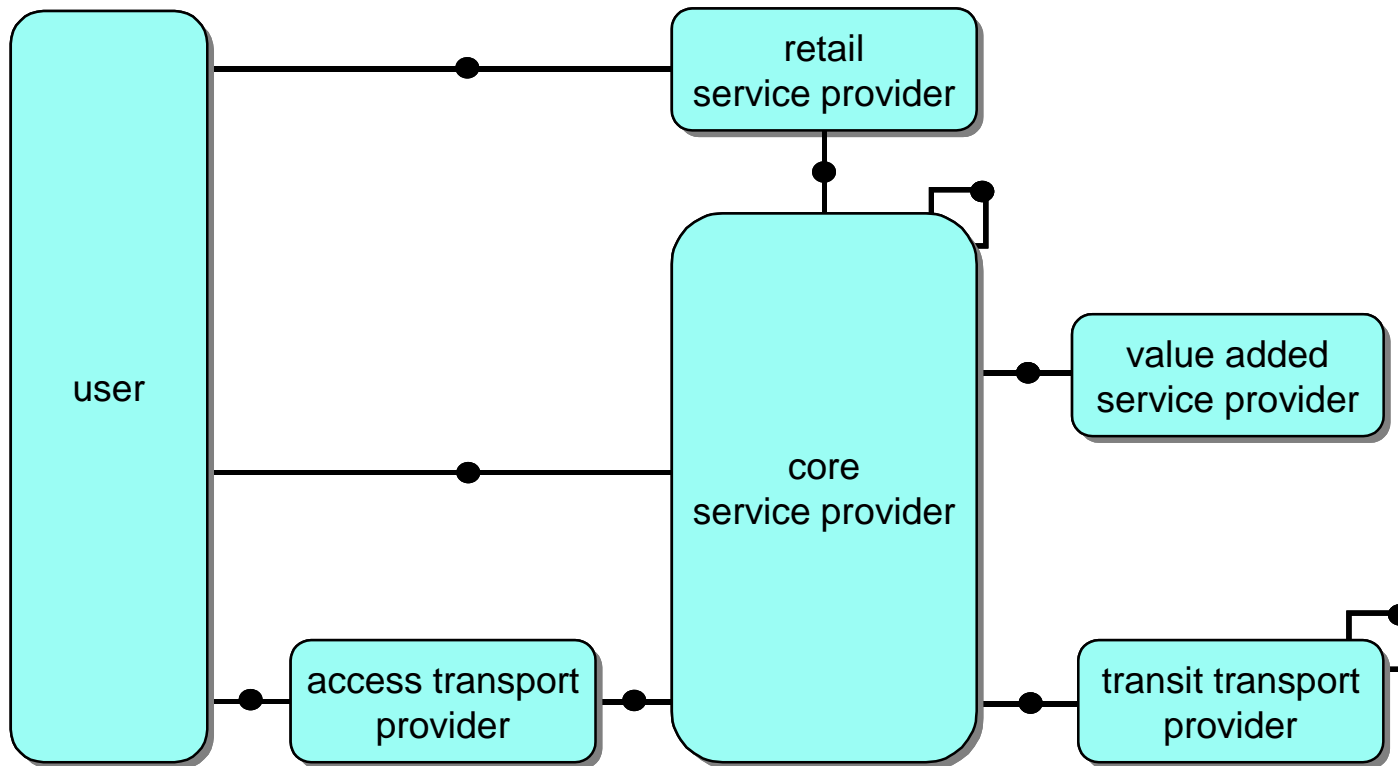



NGN roles: Second level of specialization

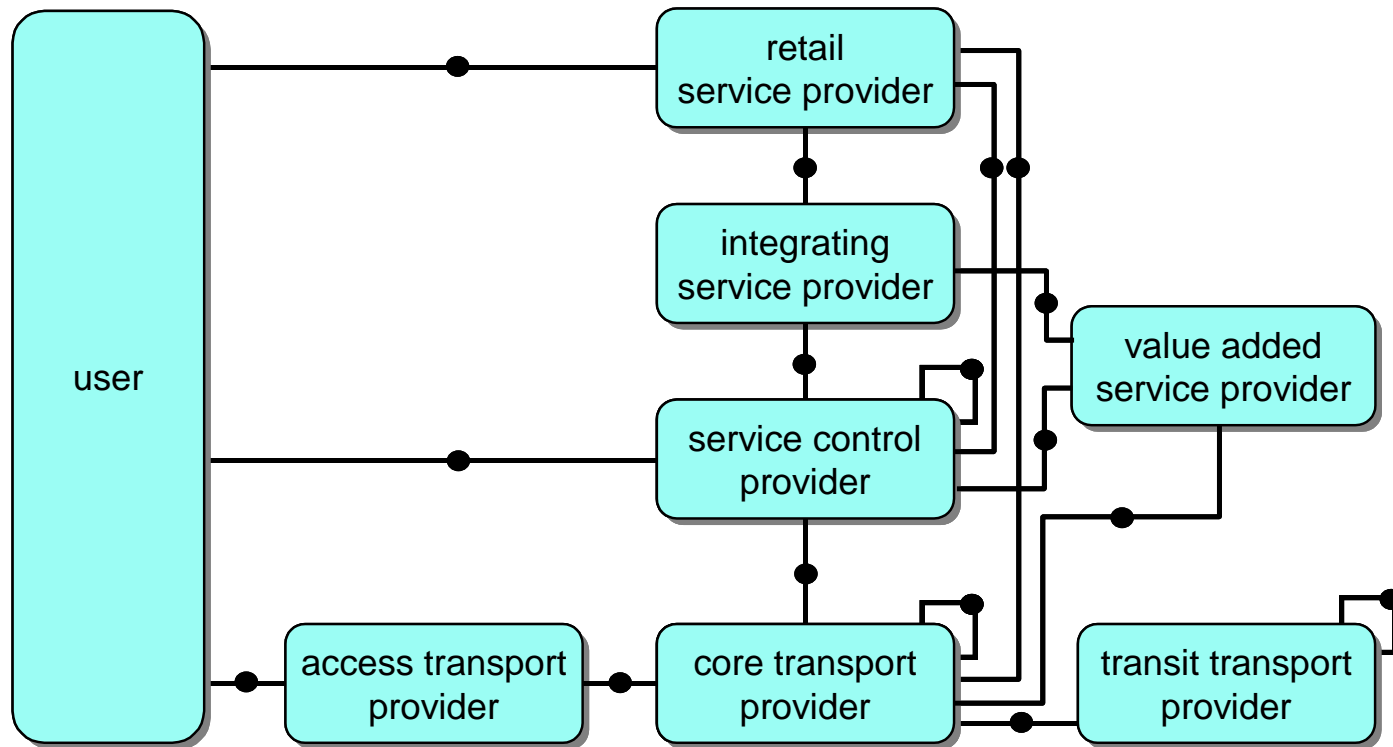



NGN; a Convergence Platform

- Combination IP with Broadband accelerating intrinsic convergence
 - Service convergence: Web based service provisioning
 - Network convergence: IP over any broadband transport networks
- Advanced Mobile and Wireless technology initiate business convergence such as Fixed-Mobile convergence
- Broadband Fixed, Wireless and Mobile technology boost another business convergence, called “Multiple Play: Tele-Broadcasting”

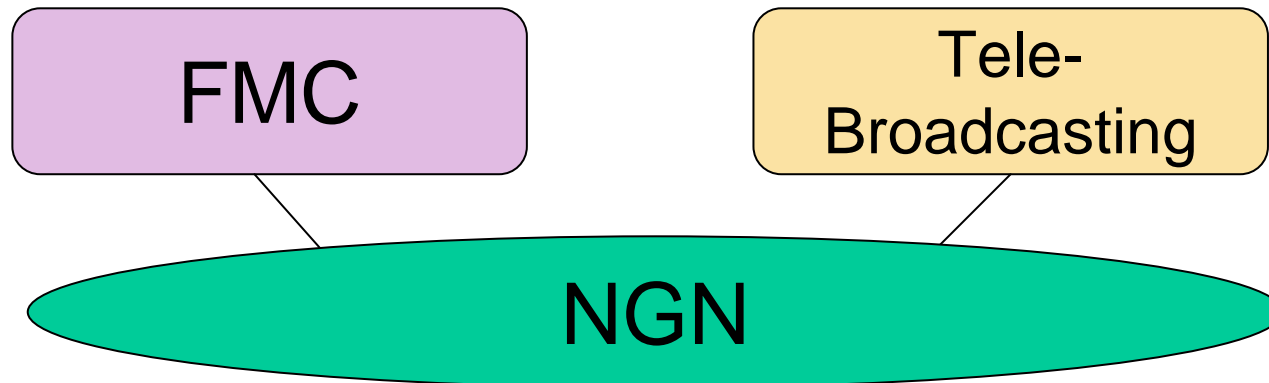



5. Utilization of NGN

NGN; Enablers for Convergence

Business/Application oriented projects

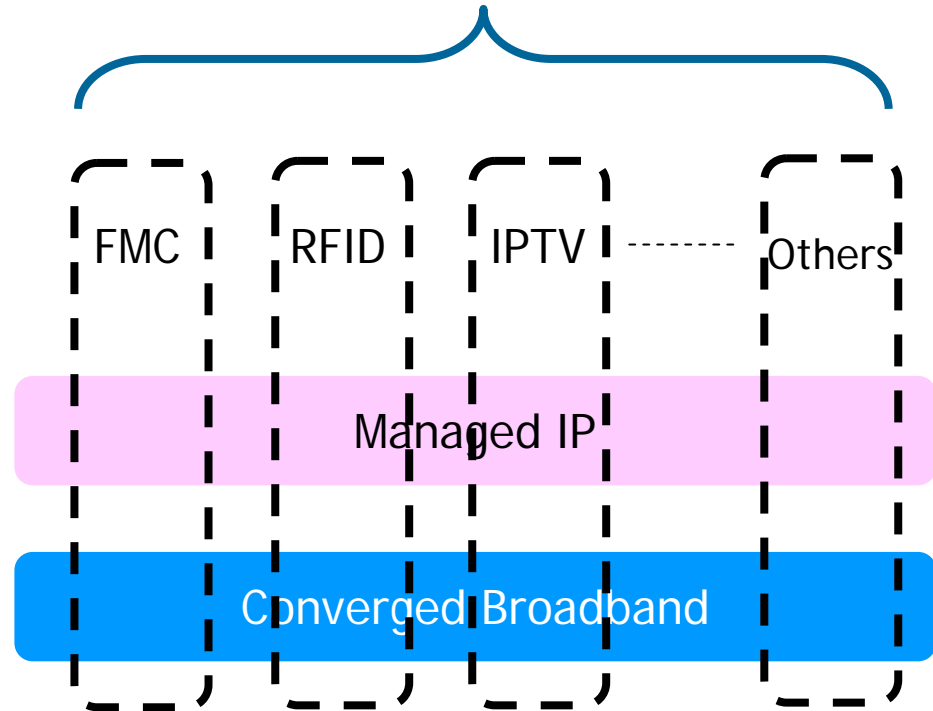
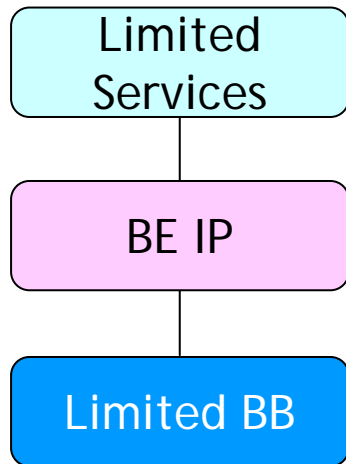

- Simple linkage btw layers
- Simple business relationships
- Simple players

- Simple linkage btw layers with dynamics
- Diverse and Flexible business relationships
- Diverse business models and players



5. Utilization of NGN

NGN as an Infrastructure for IPTV

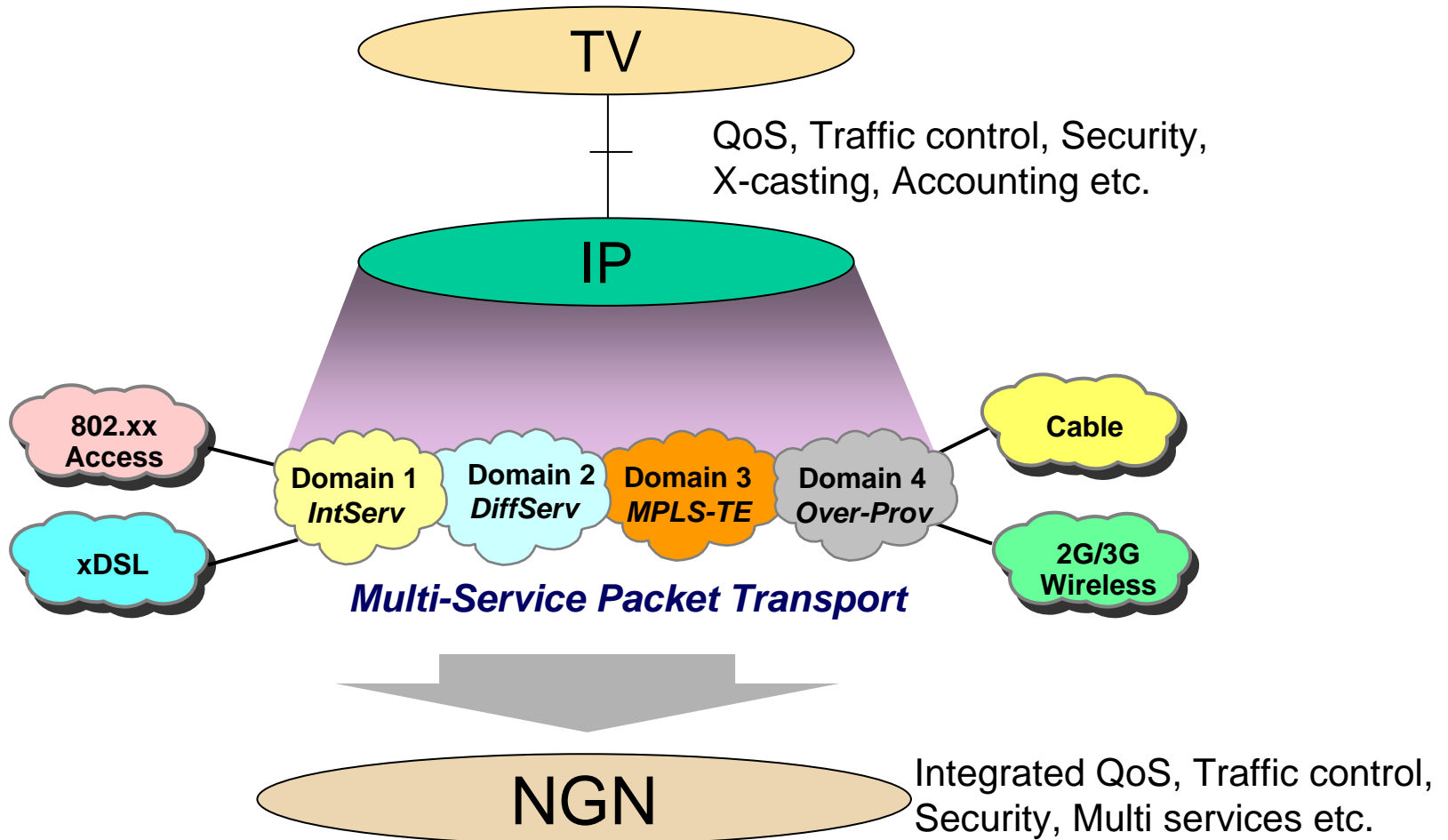



Next Direction of Global Standardization

Construction for Business/Application
(Project oriented approach)

Implementable Standards
- For Converged Infrastructure
- For Migration

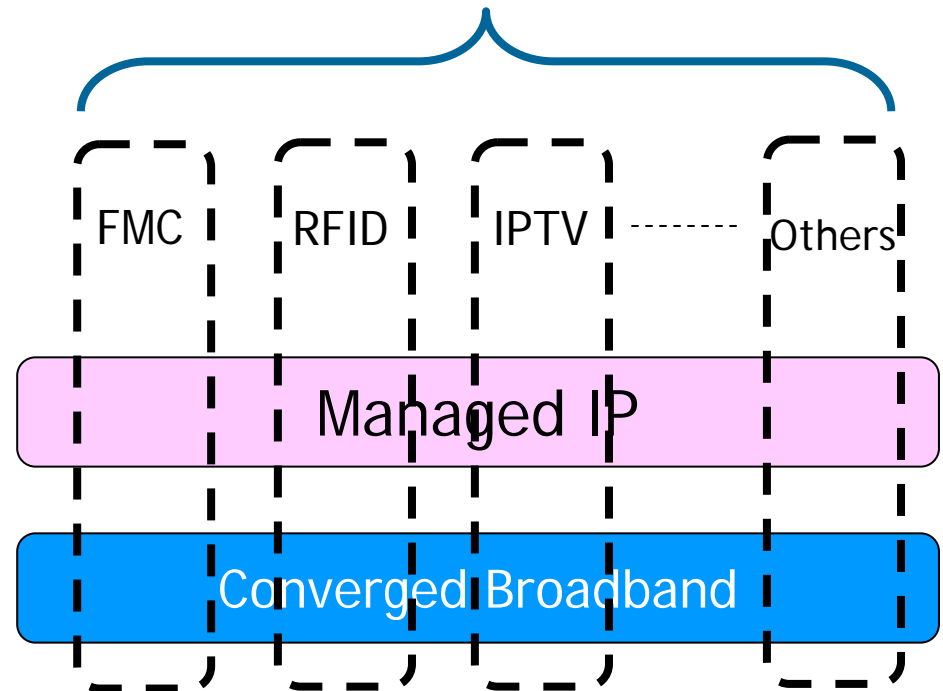



5. Utilization of NGN

Use model of NGN

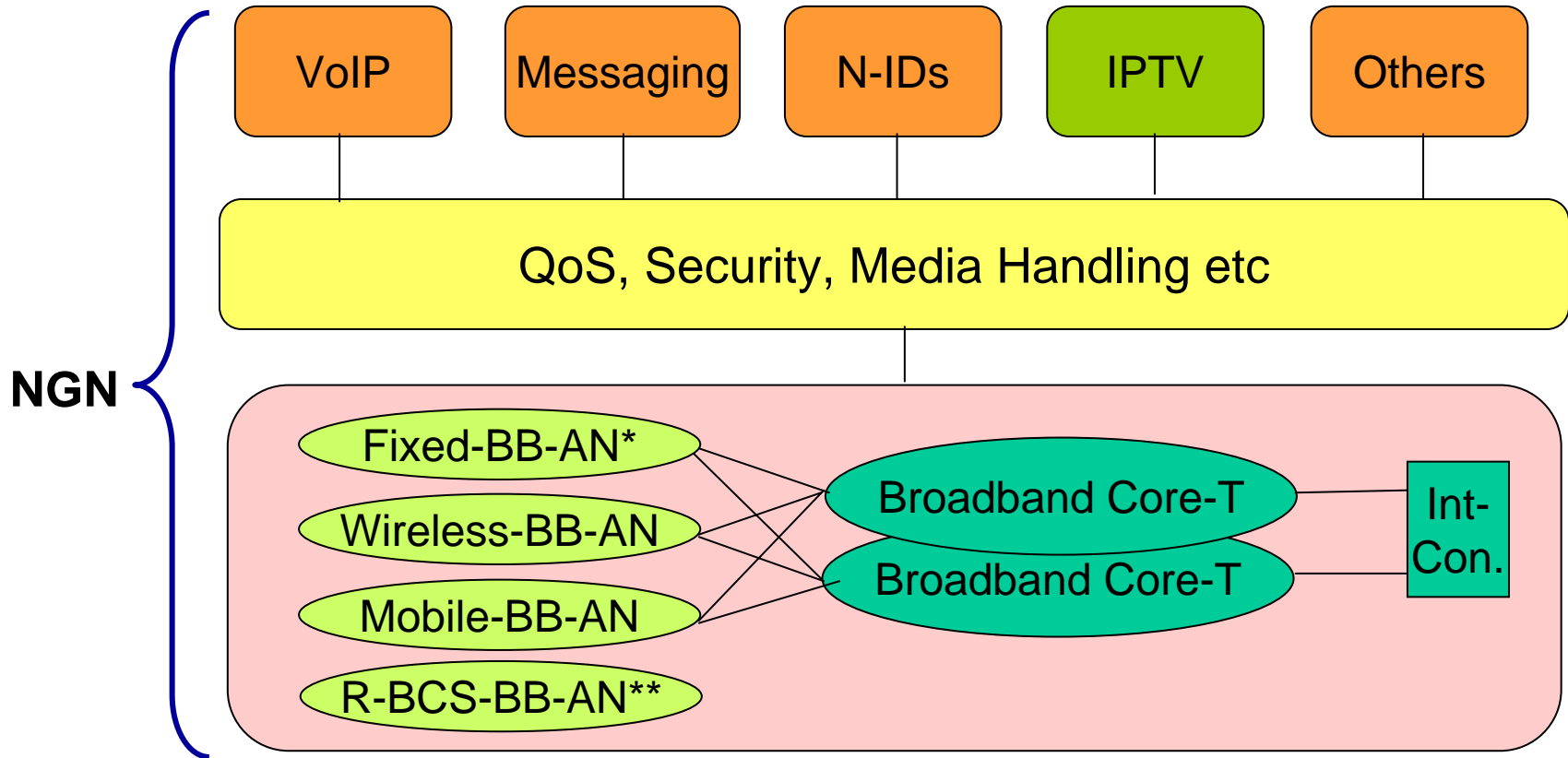

* Include cable based Broadband Access Network technology

** means radio based broadcasting transport capabilities include satellite means



6. Conclusion

Infrastructure vs. Services/Applications

- Each infras. for each Serv./Appl.
- Interworking was a big issue
- No interoperability
→ ISDN as a dream

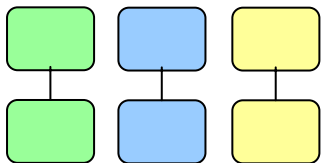

- Fixed/Mobile Infra for each F/M Serv./Appl.
- Interconnection was a big issue
→ **Forgot ISDN**

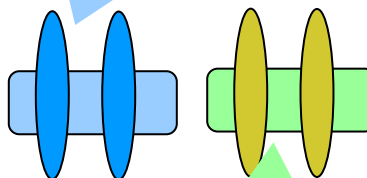

- IP infra for Internet Serv/Applications
- QoS, Security are big issue

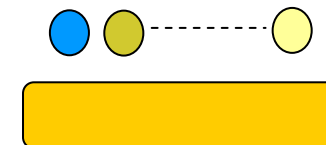

- Integrated infras. for most of Serv./Appl.
- FMC, Tele-Broad.
- Premium/Managed BB IP based Network
- Reg/Policy become issue
→ **ISDN become real**

Time



6. Conclusion

NGN : Nothing new, but upgrading, adding Value

**Up-grading
Current
Infrastructure**



**Adding
Value**



Current Generation-Beach

Next Generation-Water Park

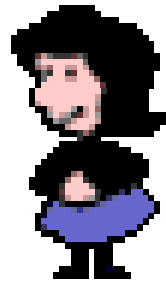

**Thank you for
your attention !!!**