

International Telecommunication Union

ITU-R
Radiocommunication Sector of ITU

Report ITU-R BS.2213-1
(05/2013)

**Impact of audio signal processing and
compression techniques on terrestrial FM
sound broadcasting emissions at VHF**

BS Series
Broadcasting service (sound)



International
Telecommunication
Union

Foreword

The role of the Radiocommunication Sector is to ensure the rational, equitable, efficient and economical use of the radio-frequency spectrum by all radiocommunication services, including satellite services, and carry out studies without limit of frequency range on the basis of which Recommendations are adopted.

The regulatory and policy functions of the Radiocommunication Sector are performed by World and Regional Radiocommunication Conferences and Radiocommunication Assemblies supported by Study Groups.

Policy on Intellectual Property Right (IPR)

ITU-R policy on IPR is described in the Common Patent Policy for ITU-T/ITU-R/ISO/IEC referenced in Annex 1 of Resolution ITU-R 1. Forms to be used for the submission of patent statements and licensing declarations by patent holders are available from <http://www.itu.int/ITU-R/go/patents/en> where the Guidelines for Implementation of the Common Patent Policy for ITU-T/ITU-R/ISO/IEC and the ITU-R patent information database can also be found.

Series of ITU-R Reports

(Also available online at <http://www.itu.int/publ/R-REP/en>)

Series	Title
BO	Satellite delivery
BR	Recording for production, archival and play-out; film for television
BS	Broadcasting service (sound)
BT	Broadcasting service (television)
F	Fixed service
M	Mobile, radiodetermination, amateur and related satellite services
P	Radiowave propagation
RA	Radio astronomy
RS	Remote sensing systems
S	Fixed-satellite service
SA	Space applications and meteorology
SF	Frequency sharing and coordination between fixed-satellite and fixed service systems
SM	Spectrum management

Note: This ITU-R Report was approved in English by the Study Group under the procedure detailed in Resolution ITU-R 1.

Electronic Publication
Geneva, 2013

© ITU 2013

All rights reserved. No part of this publication may be reproduced, by any means whatsoever, without written permission of ITU.

REPORT ITU-R BS.2213-1

**Impact of audio signal processing and compression techniques on
terrestrial FM sound broadcasting emissions at VHF**

(2011-2013)

TABLE OF CONTENTS

	<i>Page</i>
Introduction.....	2
Annex 1 – Measurement results on the protection levels against interferers with exceeded MPX power in the FM sound broadcasting.....	2
1 Measurement setup and measurement methods	3
1.1 Measurement of RF protection curves.....	6
1.2 Measurement of the reduction of the peak deviation that can compensate the effect of the higher MPX power	6
2 Measurement results	6
2.1 Measurement of RF protection curves.....	6
2.2 Measurement of the reduction of the peak deviation that can compensate the effect of the higher MPX power of the unwanted transmitter	8
Appendix to Annex 1 – List of instruments.....	11
Annex 2 – Results of measurements performed in France on the protection levels against interferers with exceeded MPX power in the FM sound broadcasting.....	12
1 The bench test.....	12
2 Measurement results	12
2.1 Statistical figure for the measurement analysis	12
2.2 Results.....	12
3 Conclusion.....	15
Appendix to Annex 2 – Measurement protocol.....	16
1 Introduction	16
2 Bench test design.....	16
2.1 Filtered white noise according to Recommendation ITU-R BS.559-2.....	16
2.2 Multiplex power (MPX) variations on interfering transmitter	17
2.3 Bench test description.....	19
2.4 Measuring process	21

Introduction

Audio signal processing techniques have developed rapidly in the last few years based on advances in digital signal compression techniques. Applying the compressed audio signal to the FM modulator can increase the modulation power without exceeding the frequency deviation limit given in Recommendation ITU-R BS.412. The processed modulation signal can also result in an increased bandwidth so increasing interference to other VHF FM stations operating on the same or adjacent channels.

Recommendation ITU-R BS.412-9 – Planning standards for terrestrial FM sound broadcasting at VHF, provides the necessary RF protection ratios under the condition that the maximum deviation of the interferer signal is 75 kHz and its multiplex power (MPX) does not exceed 0 dBr. Field measurements show that nowadays a significant number of FM transmitters exceed the 0 dBr limit of the MPX power and have a higher potential to cause interference in the reception of other FM broadcast stations and in other radio services (e.g. air radionavigation). Recommendation ITU-R BS.412-9 specifies that in these cases the transmitted RF power should be decreased, but does not provide quantitative figures for the necessary reductions. As the FM band is overcrowded and introduction of new digital stations is also considered, it is very important that the FM stations operate in line with the international regulations.

As proposed in Question ITU-R 129/6 measurements were carried out to study:

- What is the impact of audio signal processing and compression techniques on the average power of the complete multiplex signal and the maximum deviation of the emission?
- What techniques are available to ensure that the emission complies with the planning parameters given in Recommendation ITU-R BS.412 when audio signal processing and compression techniques are used?

This Report presents two summaries of measurements, one carried out in Hungary (Annex 1) and another in France (Annex 2), in order to investigate how it can be ensured that the emission complies with the planning parameters given in Recommendation ITU-R BS.412 when the 0 dBr MPX power limit is exceeded due to application of audio signal processing and compression techniques.

Annex 1

Measurement results on the protection levels against interferers with exceeded MPX power in the FM sound broadcasting

Introduction

Recommendation ITU-R BS.412-9 – Planning standards for terrestrial FM sound broadcasting at VHF, provides the necessary RF protection ratios under the condition that the maximum deviation of the interferer signal is 75 kHz and its multiplex power (MPX) does not exceed 0 dBr. Using modern audio processing/compressing techniques which result in an increase of the average power of the complete multiplex signal may lead to an increase in interference to sound broadcasting stations which do not use such techniques. Measurements were carried out in Hungary to investigate how can be ensured that the emission complies with the planning parameters given in Recommendation ITU-R BS.412 when the 0 dBr MPX power limit is exceeded due to application of audio signal processing and compression techniques.

Using modern audio processing/compressing techniques the 0 dBr MPX power limit can be exceeded while the 75 kHz limit for the maximum deviation is kept. The increased interference potential of the processed/compressed higher MPX power signal can be compensated either by decreasing the transmitted RF power or by reducing the maximum FM deviation of the transmitter. The aim of the measurements was to find quantitative figures for the reduction of the RF power and the peak deviation of the FM broadcast signal exceeding the 0 dBr MPX power limit, which can restore the audio signal-to-noise ratio (S/N) of the interfered FM broadcast service to the required 50 dB value.

1 Measurement setup and measurement methods

The measurements were carried out using the setup shown in Fig. 1 based on Recommendation ITU-R BS.641 – Determination of radio-frequency protection ratios for frequency-modulated sound broadcasting. The list of the instruments used and the main settings can be found in the Annex.

The signals of the wanted (Generator 6) and the interfering (Generator 7) transmitters were combined and applied to the FM receiver. The output audio signal of the receiver was then measured by an audio analyzer.

The wanted signal was a stereo FM broadcast signal modulated by the output of the stereo coder while the stereo coder was driven by internal 500 Hz sinusoidal sources in both (left and right) channels. The level of the modulating signal was adjusted so that the peak FM deviation of the wanted signal was 75 kHz and it remained unchanged during the whole measurement.

The interfering transmitter was modulated by processed/compressed noise plus RDS signal. The input sound signal was a weighted (coloured) noise defined by Recommendation ITU-R BS.559-2 (see Fig. 1A), which was recorded on a CD. The level of the modulating signal was adjusted so that the peak FM deviation of the unwanted signal was 75 kHz and it was checked by the modulation meter (8). The RF level of the interferer signal could be adjusted by two cascaded step attenuators ((10) and (11)) in 1 dB steps.

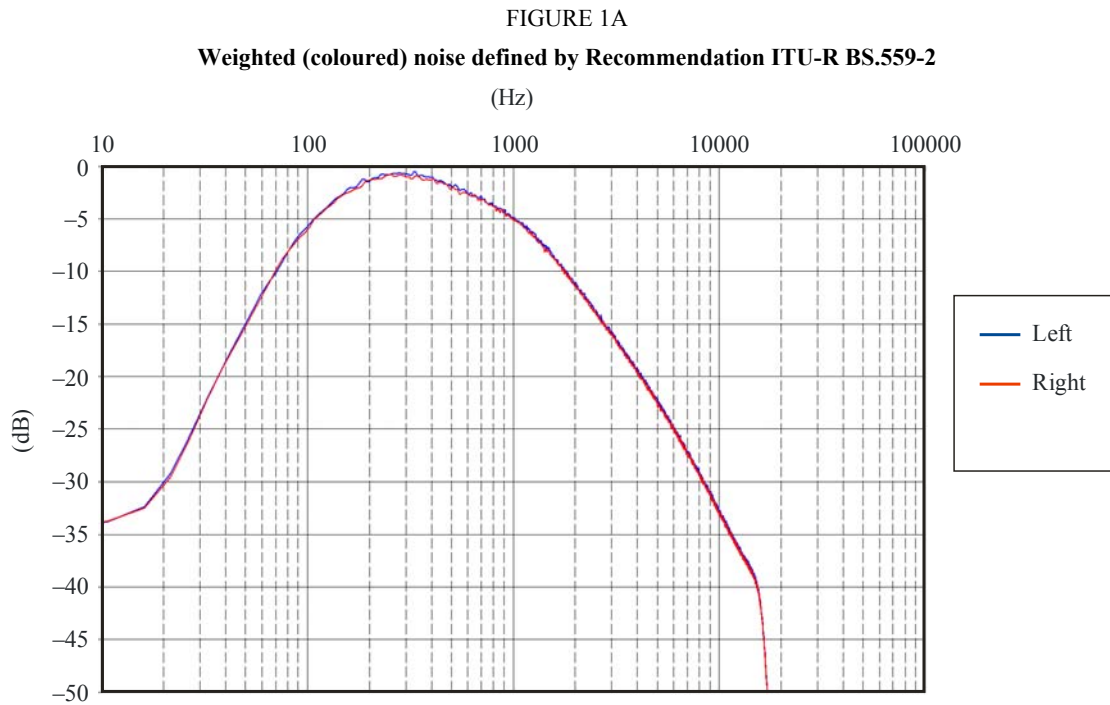

Report BS.2213-01a

The S/N ratio was observed at the audio output of the FM receiver (based on the specifications of Recommendation ITU-R BS.468-4 – Measurement of audio-frequency noise voltage level in sound broadcasting). The reference level of the signal was the level of the demodulated 500 Hz wave measured at 75 kHz peak deviation while the unwanted signal (interferer transmitter) was switched off. The level of the noise was measured using quasi-peak detector at the audio output of the FM receiver while the 500 Hz modulation of the wanted transmitter was switched off. Then the S/N ratio was calculated.

FIGURE 1

Measurement setup (the numbers in bracket refer to the list of equipment in Table 5)

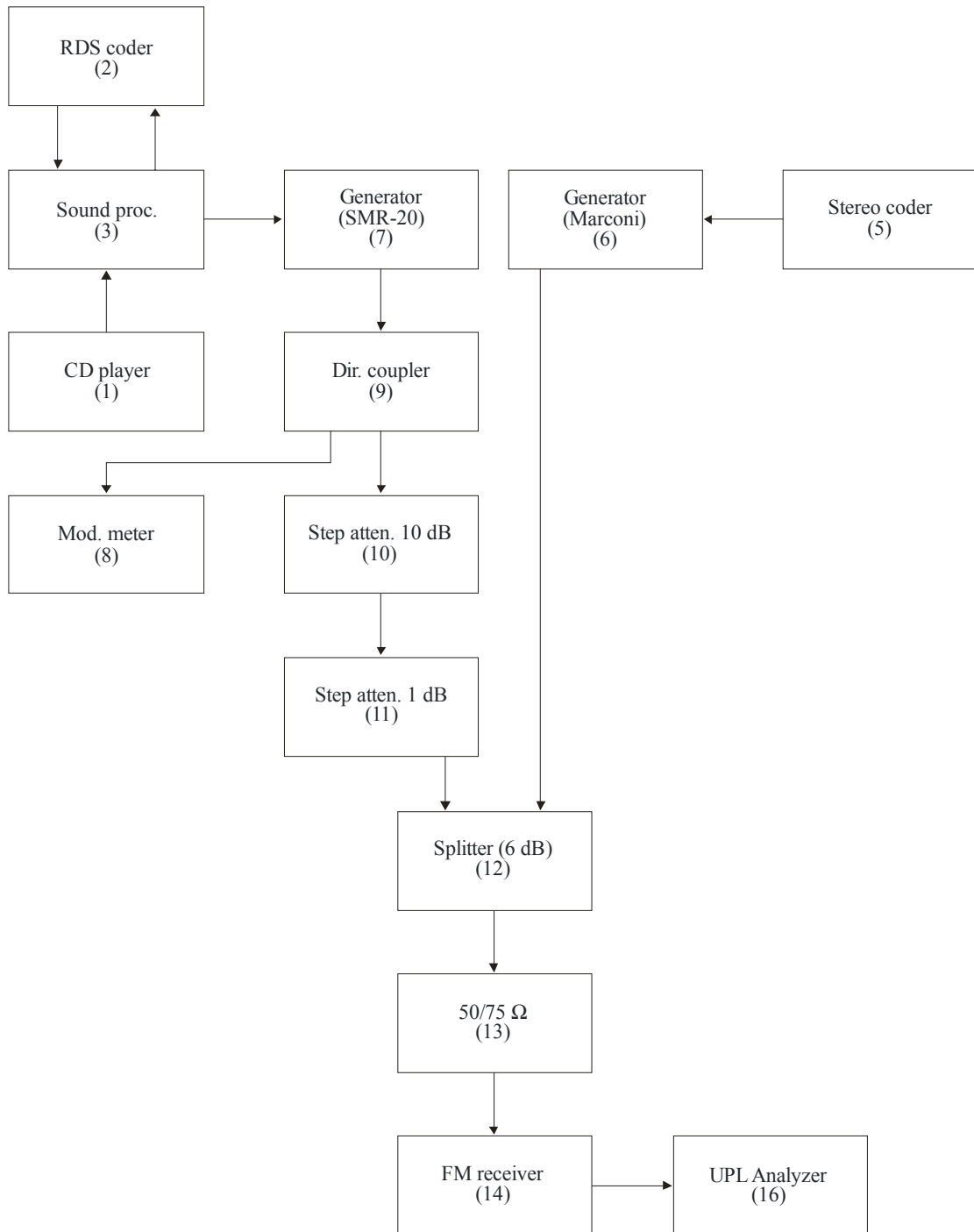

Report BS.2213-01

The RF level of the wanted transmitter at the input of the FM receiver was set to 49 dB(μ V). It was the lowest RF level where the S/N ratio at the output of the receiver reached the required 56 dB while the interferer transmitter was switched off.

1.1 Measurement of RF protection curves

The measurement procedure of the RF protection curves was as follows. The multiplex power of the interferer signal was set at the sound processor and was checked by the modulation and MPX power meter (8). The interferer transmitter was tuned to the required frequency distance from the wanted transmitter. The audio S/N ratio was observed at the output of the receiver and the step attenuators were adjusted until the S/N ratio was set to 50 dB. The actual value of the RF protection ratio was the difference in dB-s between the RF signal levels of the two transmitters. The measurement was repeated with different frequency distances and with different multiplex powers.

1.2 Measurement of the reduction of the peak deviation that can compensate the effect of the higher MPX power

The measurement setup was almost the same as in Fig. 1, except that a different type of audio analyzer (UPA) was used (for availability reasons). This measurement was completed only for 100 kHz frequency difference between the two transmitters. The RF level of the interferer signal was 33 dB below the wanted signal.

First the peak deviation of the interferer signal was set to 75 kHz in the test mode of the audio processor. The processor keeps this peak value in normal operation mode regardless of the parameters of the input sound signal and the programmed multiplex power. After setting a certain value of the MPX power the signal-to-noise ratio was observed at the audio output of the FM receiver. Then the level of the modulating signal at the output of the audio processor was adjusted until the observed S/N ratio became 50 dB. This adjustment caused of course a change in the peak deviation of the FM signal as well. The processor was then switched to test mode and the peak deviation was checked by the modulation meter (8).

2 Measurement results

2.1 Measurement of RF protection curves

The results of the RF protection curve measurements are summarized in Table 1 and Fig. 2.

TABLE 1
RF protection ratios for different multiplex power and frequency difference values

Δf (kHz)	Multiplex power (dBr)								
	0	0.5	1.5	2.5	3.5	4.5	5.5	6.5	7.5
0	42.5	43	44	46	47	48	48	49	49
50	52	52	52	52	51	51	51	50	50
100	32.5	33	35	36	38	39	41	43	44
150	11	13	16	18	20	23	25	26	27
200	-11	-10	-7	-3	0	2	5	7	8
250	-26.5	-26	-25	-23	-21	-19	-16	-15	-13
300	-28	-28	-28	-28	-26	-28	-28	-28	-26

FIGURE 2
RF protection ratios for different multiplex power and frequency difference values

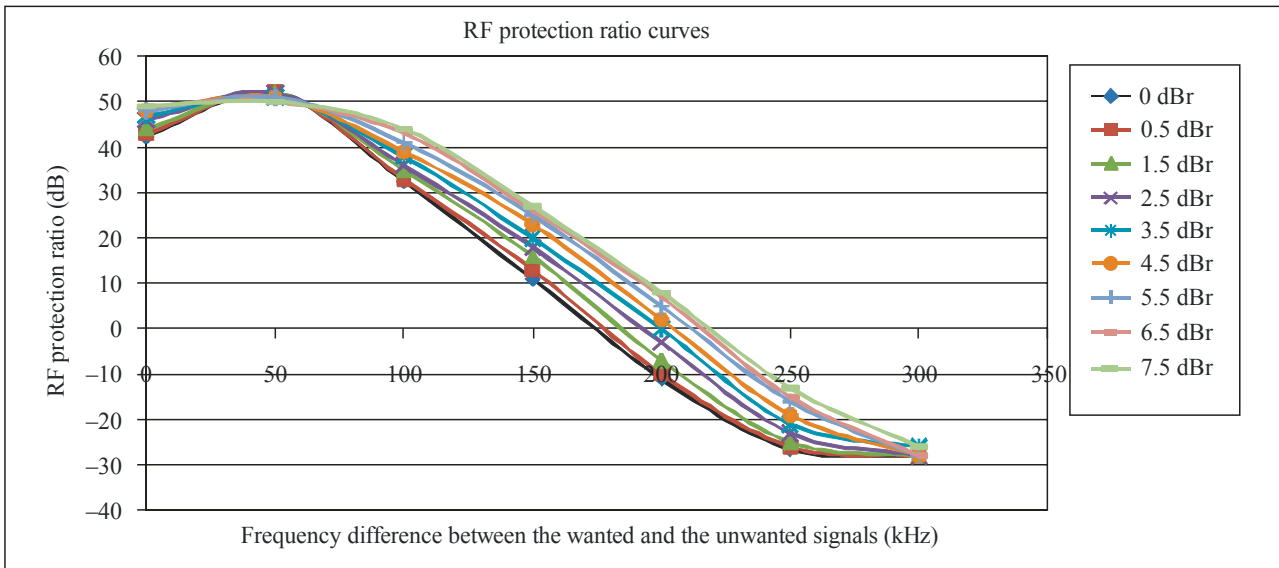

Report BS.2213-02

It can be seen that – in spite of certain expectations – the measured 0 dBr protection curve is not identical with the S1 curve shown in Recommendation ITU-R BS.412-9. The most likely reasons of the difference is that the S1 curve of Recommendation ITU-R BS.412-9:

- a) represents an average of the measurements made on a great number of different consumer radio sets while for the present measurements only two different, medium quality radio sets were used; and
- b) it was measured with an interferer signal with less than 0 dBr MPX power.

However, the curves clearly indicate the tendency that the higher the MPX power the more protection is needed against it.

From the above results we can also derive curves that show how much reduction of the RF power level of an interferer signal can compensate its increased interfering effect if its MPX power exceeds 0 dBr, keeping the baseband audio *S/N* ratio at the required 50 dB. The three curves on Fig. 3 refer to the 0 kHz, 100 kHz and 200 kHz difference between the carrier frequencies of the wanted and the unwanted signal.

TABLE 2
RF power reduction that can compensate the effect of the higher MPX power of the unwanted transmitter

Δf (kHz)	MPX power (dBr)							
	0.5	1.5	2.5	3.5	4.5	5.5	6.5	7.5
0	0.5	1.5	3.5	4.5	5.5	5.5	6.5	6.5
100	0.5	2.5	3.5	5.5	6.5	8.5	10.5	11.5
200	1	4	8	11	13	16	18	19

FIGURE 3

RF power reduction that can compensate the effect of the higher MPX power of the unwanted transmitter

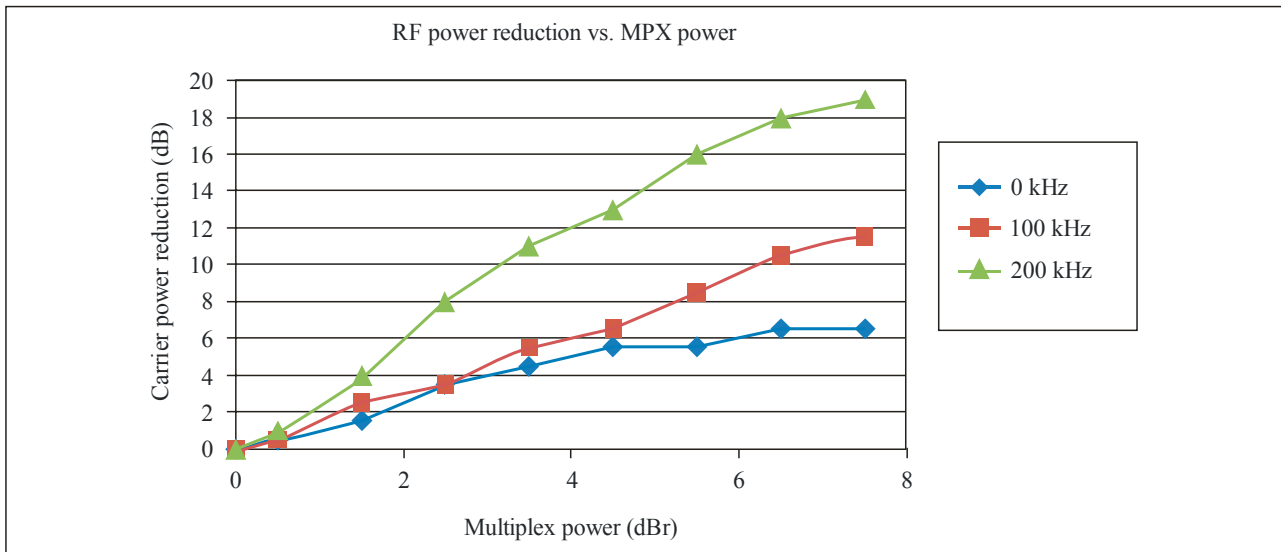

Report BS.2213-03

2.2 Measurement of the reduction of the peak deviation that can compensate the effect of the higher MPX power of the unwanted transmitter

The higher interference potential of a signal exceeding 0 dBr multiplex power can also be compensated by the proportional reduction of the FM deviation. Table 3 and Fig. 4 show the applicable maximum deviations as a function of the original MPX power (before decreasing the peak deviation). The two curves refer to the “on” and “off” state of the RDS signal.

The results of the measurements of the maximum applicable peak deviation are summarized in Table 3 and Fig. 4.

TABLE 3

Peak deviations for different MPX power values

Maximum applicable FM deviation (kHz)		
Multiplex power (dBr)	RDS on	RDS off
1	71.5	69.7
2	61.5	63.3
3	56.8	56.8
4	51.6	50.4
5	48	46.9
6	46.3	43.9
7	45.1	42.2

FIGURE 4

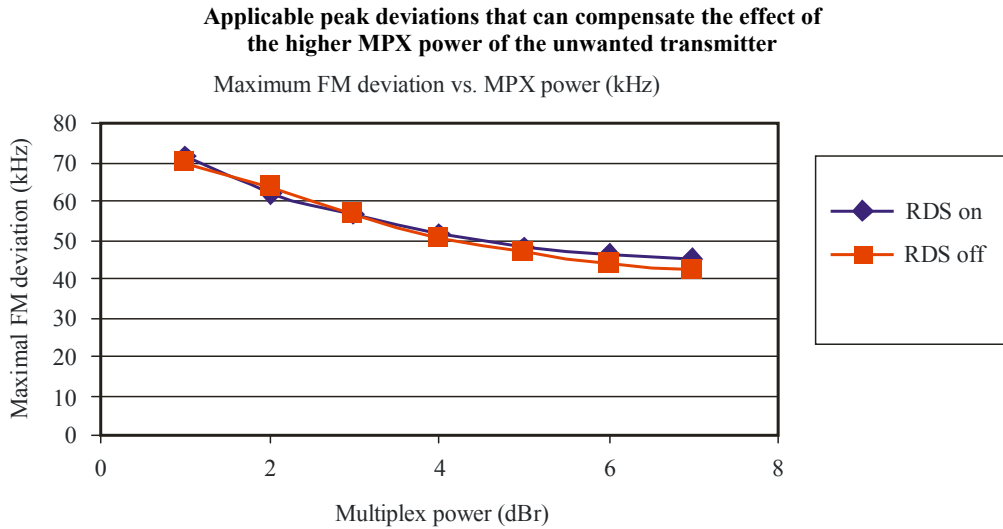

Report BS.2213-04

The measurements were carried out both in the “on” and “off” state of the RDS signal. It was found that this causes only a very slight difference.

The above results can be expressed in the reduction of the peak deviation – relative to the nominal 75 kHz – as well.

TABLE 4

Reduction of the peak deviations that can compensate the effect of the higher MPX power of the unwanted transmitter (relative to 75 kHz)

Reduction of the peak FM deviation (kHz)		
Multiplex power (dBr)	RDS on	RDS off
1	3.5	5.3
2	13.5	11.7
3	18.2	18.2
4	23.4	24.6
5	27	28.1
6	28.7	31.1
7	29.9	32.8

FIGURE 5

Reduction of the peak deviations that can compensate the effect of the higher MPX power of the unwanted transmitter (relative to 75 kHz)

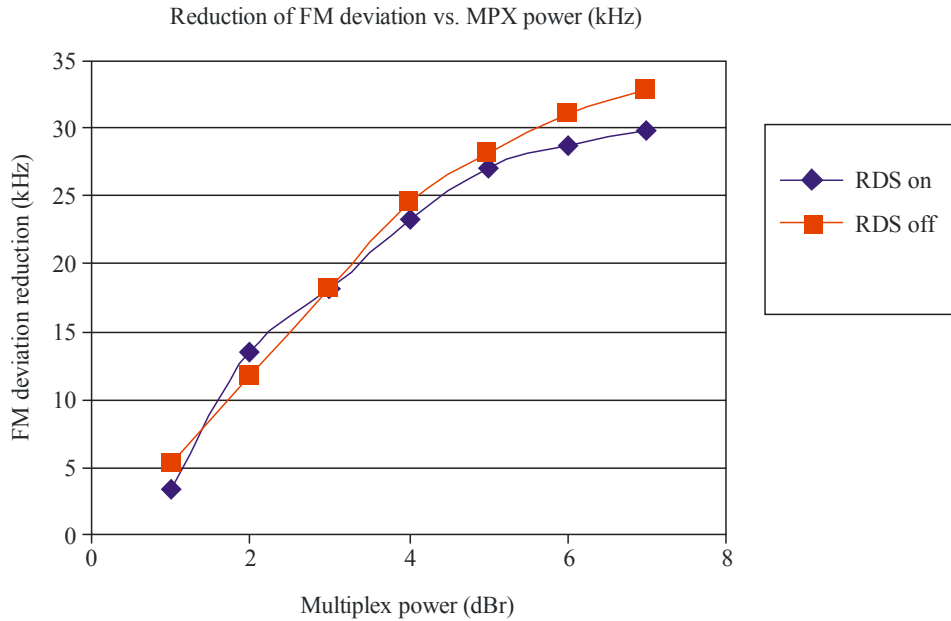

Report BS.2213-05

Conclusion

The laboratory measurements confirmed that FM broadcast signals with higher multiplex power can cause higher degradation in the quality of the interfered FM broadcast signal. This degradation can be compensated by decreasing either the RF level or the peak deviation of the interferer signal. The above described measurements provide quantitative figures for the amount of these reductions.

Appendix to Annex 1

List of instruments

TABLE 5

List of instruments

No.	Equipment/type	Serial or Reg. No.
1	CD player (in an industrial PC)	L0064576
2	RDS coder	
3	Audio processor Orban 5300 FM	53000135
4	Function generator Tektronix AFG 3252	
5	Stereo coder R&S MSC-2	890340/017
6	Signal generator Marconi 2031 (wanted transm.)	119848/053
7	Signal generator R&S SMR-20 (unwanted transm.)	11040002.20
8	Modulation (and MPX) meter Audemat Aztek FM-MC4	L0062277
9	High power directional coupler C5091 (Werlaton)	10279
10	Step attenuator 8496A 10 dB	3308A14564
11	Step attenuator 8494A 11 dB	3308A32544
12	Resistive power splitter Aeroplex 1870A	8134
13	50/75 Ohm match RAM	100131
14	Radio set Sony S-master CMT-CPZ1	122234
15	Radio set Denon DN-U100	
16	UPL Audio Analyzer R&S DC...110 kHz	100091
17	UPA Audio Analyzer R&S 10 Hz 100 kHz	

Signal and instrument settings

Signal level of the wanted transmitter at the receiver input: 49 dB(μ V)

Pilot signal: 9%

FM deviation caused by the RDS signal: 3 kHz

UPL audio analyzer

Low-pass filter: on (15 kHz)

Detector: quasy-peak

Weighting filter: on (weighting characteristics according to Recommendation ITU-R BS.468-4)

UPA audio analyzer

Low-pass filter: on (22 kHz)

Detector: quasy-peak

Weighting filter: on (weighting characteristics according to Recommendation ITU-R BS.468-4)

Audemat Aztec FM-MC4 modulation (and MPX) analyzer

Mode of operation: MPX Analysis Mode (In this mode the averaging time is automatically set to 200 ms and the MPX processing mode to “linear”).

Orban 5300 FM audio processor

Applied factory preset: “Extreme”.

Annex 2

Results of measurements performed in France on the protection levels against interferers with exceeded MPX power in the FM sound broadcasting

1 The bench test

The French Administration has carried out a bench test using 26 receivers to study the impact of the increase of multiplex power on protection ratios. The results of these measurements carried out in France to quantify the impact of multiplex power over protection ratios (PR) when the limit of 0 dBr is exceeded are included in this Annex, which provides quantitative figures of required protection ratios, according to the values of multiplex power (MPX) used by some broadcasting FM stations.

2 Measurement results

2.1 Statistical figure for the measurement analysis

The ninth decile statistical figure has been chosen in order to show a representative analysis of the measurement results. It was more representative than the median or the average to describe the statistical behaviour of receivers during the experimentation.

Furthermore, the statistical ninth decile figures represent protection ratios of a theoretical receiver which is less efficient than the 90% of the sample receivers tested.

The PR values taken as reference are given in Recommendation ITU-R BS.412-9 (§ 2.3.2, Table 3: Stereophonic mode and steady interference).

2.2 Results

As shown in Fig. 6 below, some receivers (more than 10%) are protection ratio values close to those found in Recommendation ITU-R BS.412-9, where no multiplex power applies to the interfered signal at 100, 200, 300 and 400 kHz of the carrier frequency spacing.

FIGURE 6

RF protection ratios for 0 dB_r multiplex power and carrier frequency spacing difference values for the 26 receivers tested

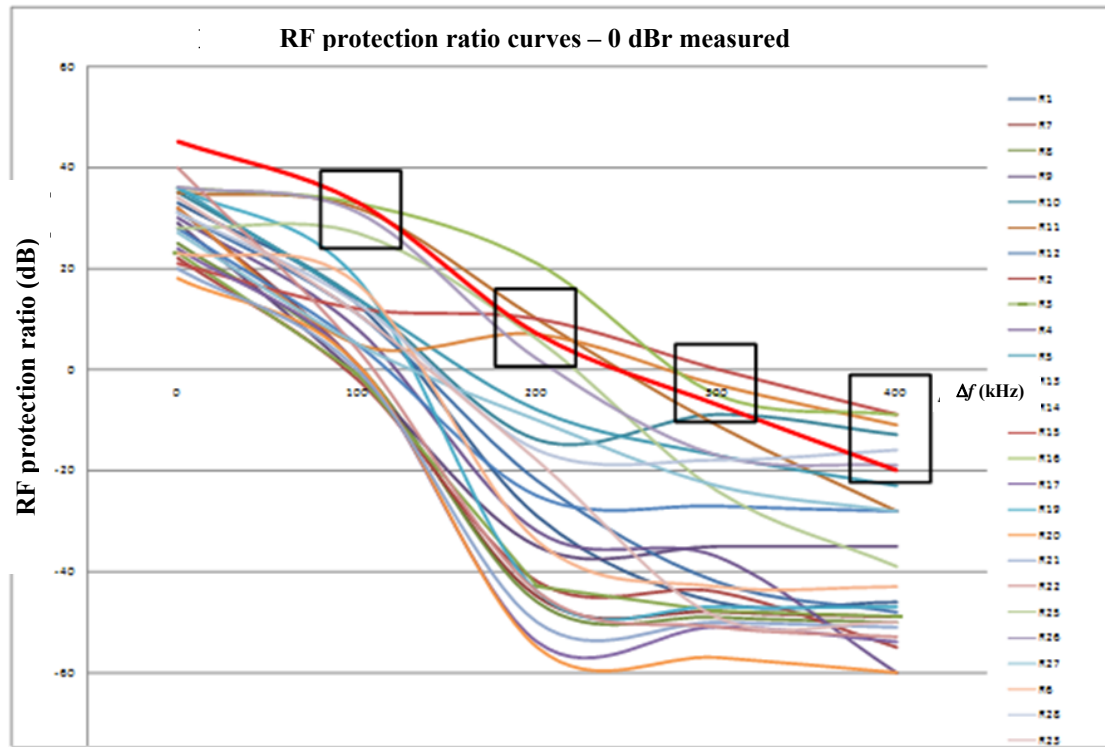

The bold red curve represents the PR in Recommendation ITU-R BS.412-9.

Figure 6 shows that the protection ratios given in Recommendation ITU-R BS.412-9 are still relevant even if a lot of receivers have better protection ratios.

Figure 7 below shows several protection ratios measured for different values of multiplex power. As indicated in § 2.1, the following curves represent a theoretical receiver which ensures that 90% of the sample receivers tested will work properly.

FIGURE 7

RF protection ratio curves for several multiplex power values using frequency carrier spacing values (by steps of 100 kHz)

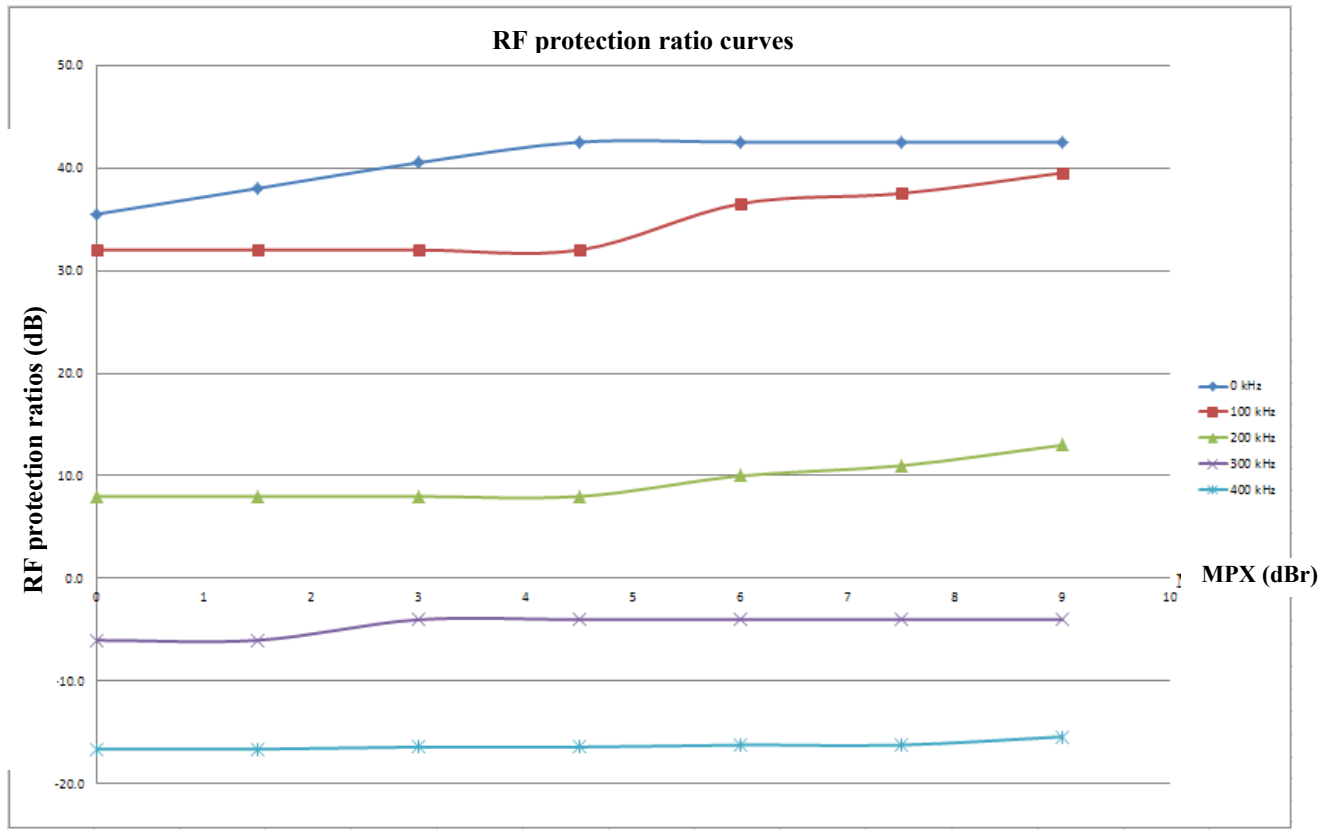

As shown on Fig. 7, it is important to note that at 300 kHz and 400 kHz of the carrier frequency spacing, the differences between the PR measured at 0 dBr multiplex power and at 9 dBr are very low.

Thus, only carrier frequency spacing of 0 kHz, 100 kHz and 200 kHz are taken into account for the final results.

Table 6 shows the value of the PR measured for different values of multiplex power applied to the interfered signal at different carrier frequency spacings: 0, 100 and 200 kHz.

TABLE 6

RF protection ratios for different multiplex power and frequency difference values

MPX	< 5 dBr	6 dBr	7.5 dBr	9 dBr	Rec. ITU-R 412-9
Δf	RF protection ration measured (dB)				
0 kHz	42.5	42.5	42.5	42.5	45
100 kHz	32.0	36.5	37.5	39.5	33
200 kHz	8.0	10.0	11.0	13.0	7

According to the measurements made on receivers, for a multiplex power less than 5 dBr, the PR obtained does not exceed: 42.5 dB at 0 kHz of the carrier frequency spacing, 32 dB at 100 kHz and 8 dB at 200 kHz.

But for a multiplex power greater than 5 dBr, the PR measured keeps growing as the multiplex power increases.

Compared to the PR values mentioned in Recommendation ITU-R BS.412-9, the decrease of RF power that can counterbalance the effect of a higher multiplex power of the unwanted transmitter is shown in Table 7.

TABLE 7
Decrease of RF power that can compensate the effect of the higher MPX
power of the unwanted transmitter

MPX	< 5 dBr	6 dBr	7.5 dBr	9 dBr	Rec. ITU-R 412-9
Δf	RF protection ration measured (dB)				
0 kHz	+2.5	+2.5	+2.5	+2.5	45
100 kHz	+1.0	-3.5	-4.5	-6.5	33
200 kHz	-1.0	-3.0	-4.0	-6.0	7

The negative figures represent the necessary decrease of RF power that can compensate the effect of multiplex power to ensure the protection of the wanted signal.

The positive figures show that PR values of Recommendation ITU-R BS.412-9 can be decreased by each value according to the case considered. For example, for a carrier frequency spacing of 0 kHz, the trial has shown the possibility to use 42.5 dB of protection ratio (between a wanted signal which did not use the multiplex power and an unwanted signal which did use the multiplex power) instead of 45 dB as indicated in Recommendation ITU-R BS.412-9.

3 Conclusion

The test bench results performed in France in 2012 have confirmed that FM broadcast signals with higher multiplex power are degrading protection ratios and can worsen the quality of the interfered FM broadcast signal. However, by widening the amount of receivers taken into account in the measurements, the figures of the protection ratio obtained in Annex 1 are slightly different.

The main conclusion is that PRs in Recommendation ITU-R BS.412-9 are still relevant for multiplex power that do not exceed 5 dBr for any frequency spacing between the wanted and the unwanted signals. For signals that exceed 5 dBr, it is necessary to reduce the transmitter RF power according to the values shown in Table 7.

Furthermore, the measurements show better performance for receivers put into market after 2010 (35% of the tested receivers). This could be due to a majority of 2010's FM receivers using digital components. This trend could enable the use of a lower protection ratio in the long term and a possible revision of Recommendation ITU-R BS.412 if a new measurements campaign assessed it.

Appendix to Annex 2

Measurement protocol

1 Introduction

The bench test is based on Recommendation ITU-R BS.641 used to set protection ratios according to the multiplex power variations and the spacing of carrier frequencies. The bench test involved a representative sample of 26 receivers.

This document explains the methodology and the means used to carry out the bench test.

2 Bench test design

This first part explains how to get some technical elements required for the bench test:

- 1) the coloured noise signal;
- 2) the equipment that enables the multiplex power variations.

After that, the bench test is set up according to the diagram of measuring given in Recommendation ITU-R BS.641.

The second part describes the bench test configuration, which is adapted in order to match with the modern metrology methods.

2.1 Filtered white noise according to Recommendation ITU-R BS.559-2

The multiplex power variations depend on the noise modulating signal given in Recommendation ITU-R BS.559-2. In order to obtain the coloured noise signal spectrum as defined in the recommendation "...the spectral amplitude distribution of which is fairly close to that of modern dance music...", it is necessary to use a filtered white noise signal proceeding from an AF generator signal according to the diagrams below (Figs 8 and 9).

FIGURE 8

Recommendation ITU-R BS.559-2 Filter diagram

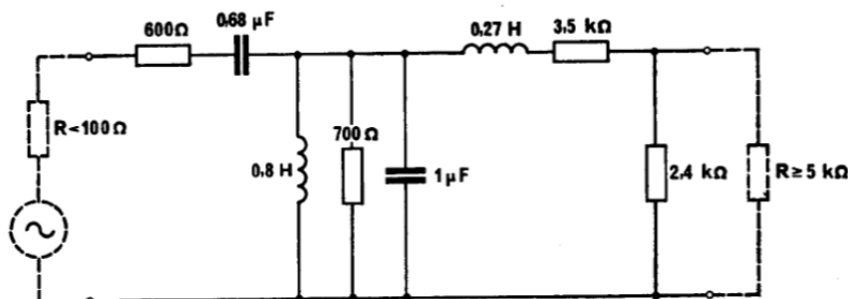

Frequency/Amplitude AF measured

FIGURE 9
Weighted (coloured) noise defined by Recommendation ITU-R BS.559-2

Audio Precision

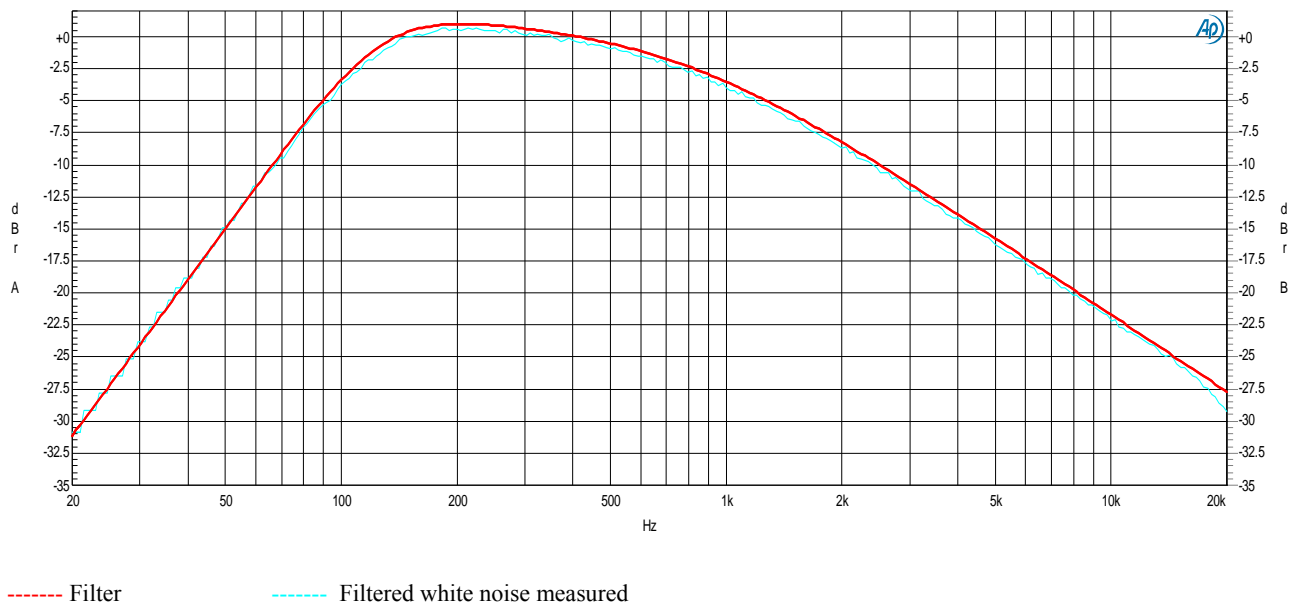

The coloured noise obtained was recorded in a specific VX222HR audio card from DIGIGRAM.

This file was saved in a PCM (48 kHz – 16 bit) format and can be read by any professional audio card. It just requires a digital or analog audio output.

The device SYSTEM TWO from AUDIO PRECISION was selected to provide a white noise signal. (Set up: Noise – White Pseudo).

2.2 Multiplex power (MPX) variations on interfering transmitter

A Principle

The MPX variation is achieved by using a sound processing system often used in the FM sound broadcasting service.

The device selected is an OMNI ONE FM. It consists of a stereo coder, which embeds processing and optimization sound features, used in FM sound broadcasting.

The OMNIA ONE FM can achieve the following functionalities:

- 1 Filtering at 15 kHz
- 2 Pre-emphasis of 50 μ s
- 3 Limitation and optimization of level composite output in order to comply with the maximal level fixed at $8.72V_{c/c}$. This condition ensures that the maximum frequency deviation of ± 75 kHz would not be exceeded.

The audio processing is based on AF signals dynamic compression techniques. The processing is achieved by a set of cells working in a specific frequency band. Each audio frequency band, cut out beforehand, is handled by a set of functions: dynamic compressor and limiter.

Then, the audio spectrum is reconstructed in order to be injected in the stereo coder. This last function includes a clipper, which eliminates the over-shoot. This handling ensures to keep the MPX in a tension range ($8.72 V_{c/c}$) and the maximum frequency deviation less than 75 kHz.

Therefore, the AF signal dynamic range could be reduced according to the device settings. This reduction increases the MPX of the signal.

The RF wanted signal is generated by a FM THOMSON-LGT RAMSES II transmitter. The stereo coder integrated is put into operation.

B Interfering signal line

The bench test interfering signal line consists of the following devices:

- A PUC 2 YELLOWTEC card, which generates a coloured noise as a AES/UER signal
- A set up Mono OMNIA ONE FM
- A FM RVR PTX 100LCD transmitter.

Concerning the measurement in static mode, the following settings are used:

- The control of the maximum deviation is achieved by the FMA of Rohde & Schwarz;
- The spectrum analyser E4402B of HP shows the J0 carrier cancellation;
- The modulating signal MPX is measured with the ADFM02 analyser.

Concerning the measurement in dynamic, following settings are used:

- MPX variations and frequency deviations are analysed with the ADFM02.

This part of the bench test and its measurements modes are shown on Fig. 10.

FIGURE 10
Diagram of the interfering signal line

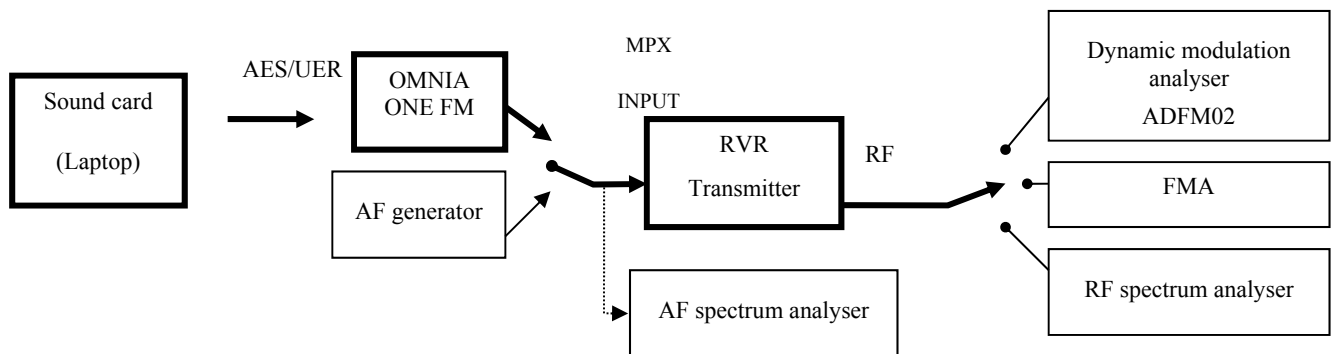

2.3 Bench test description

The bench test is built according to the diagram of measuring apparatus reproduced below:

FIGURE 11

Diagram of the measuring apparatus

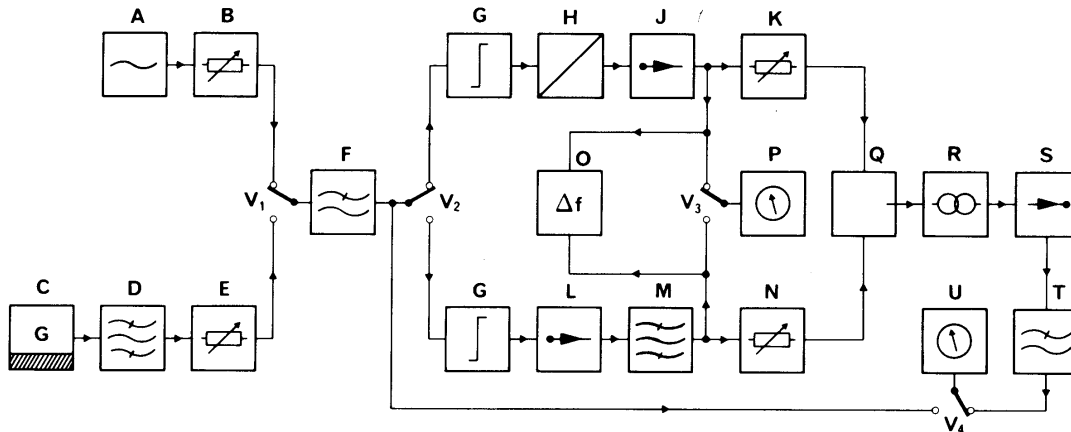

FIGURE 1 – Diagram of the measuring apparatus

- | | | |
|--|---|---|
| A: 500 Hz AF generator (for transmitter line-up procedure) | K: calibrated RF attenuator | T: 15 kHz low-pass filter |
| B: calibrated AF attenuator | L: signal generator (unwanted signal) | U: psophometer (switchable weighting network) |
| C: noise generator | M: RF band-pass filter (tuneable) | V ₁ : selector switch for the modulation |
| D: noise shaping filter complying with Recommendation 559 | N: calibrated RF attenuator | V ₂ : selector switch for modulating one or other of the signal generators |
| E: calibrated AF attenuator | O: frequency-meter for measuring the frequency difference between signal generators J and L | V ₃ : selector switch for the frequency-deviation meter (J and L generators) |
| F: 15 kHz low-pass filter | P: frequency-deviation meter | V ₄ : selector switch for measuring the AF signal levels |
| G: pre-emphasis network | Q: coupling device | |
| H: stereo coder | R: matching network | |
| J: signal generator (wanted signal) | S: receiver under test | |

D01-sc

A modern version of this bench test is presented below. It contains, in a macroscopic model, all the elements given in the reference diagram (Recommendation ITU-R BS.641). A correspondence between the diagram given in the recommendation and the new version is shown below (Letters “A” to “U”).

The tested equipment (the receiver) is put in a Faraday cage that shields the receiver from any radio interferences around.

FIGURE 12

Proposed bench test diagram

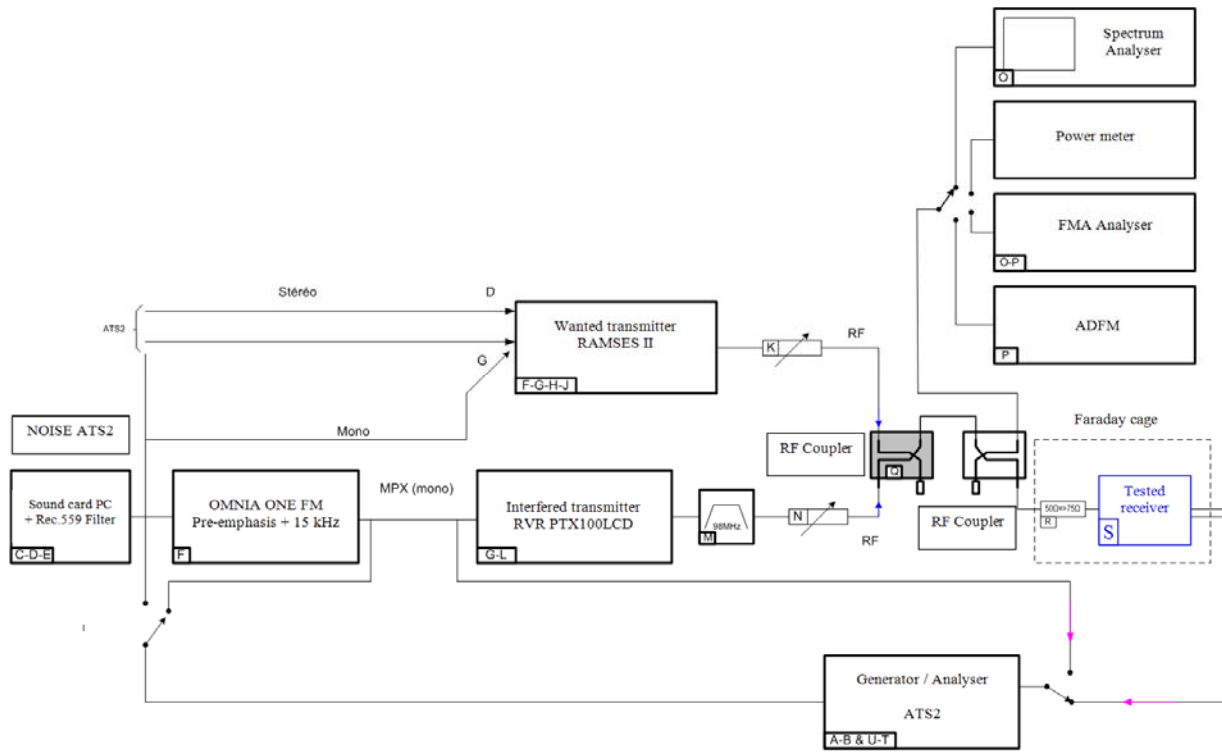

FIGURE 13

Wanted and interfering transmitters, clipper/Faraday Cage (at left) – measuring devices (At right)



2.4 Measuring process

The measurement process used for the bench test follows exactly the methodology described in Recommendation ITU-R BS.641.

The protection ratio is obtained when the following calculation is achieved:

$$PR = (P_u - Att_u) - (P_b - Att_b)$$

Where:

P_u is the RF wanted transmitter power;

Att_u is the RF wanted transmitter attenuation that enables to fix the S/N at 56 dB, when the interfering transmitter is not activated, as recommended;

P_b is the RF interfering transmitter power;

Att_b is the RF interfering transmitter attenuation that enables to fix the S/N at 50 dB, when the interfering transmitter is activated.

In order to ease the protection ratio calculation, the power level of wanted and interfering signal is the same.

So the protection ratio is: $PR = Att_b - Att_u$.

This measurement process is also described in Fig. 14.

FIGURE 14

Diagram of the measurement process

