

International Telecommunication Union

**ITU-R**  
Radiocommunication Sector of ITU

**Report ITU-R BT.2049-3**  
(05/2009)

**Broadcasting of multimedia and data  
applications for mobile reception**

**BT Series**  
**Broadcasting service**  
**(television)**



International  
Telecommunication  
Union

## Foreword

The role of the Radiocommunication Sector is to ensure the rational, equitable, efficient and economical use of the radio-frequency spectrum by all radiocommunication services, including satellite services, and carry out studies without limit of frequency range on the basis of which Recommendations are adopted.

The regulatory and policy functions of the Radiocommunication Sector are performed by World and Regional Radiocommunication Conferences and Radiocommunication Assemblies supported by Study Groups.

## Policy on Intellectual Property Right (IPR)

ITU-R policy on IPR is described in the Common Patent Policy for ITU-T/ITU-R/ISO/IEC referenced in Annex 1 of Resolution ITU-R 1. Forms to be used for the submission of patent statements and licensing declarations by patent holders are available from <http://www.itu.int/ITU-R/go/patents/en> where the Guidelines for Implementation of the Common Patent Policy for ITU-T/ITU-R/ISO/IEC and the ITU-R patent information database can also be found.

### Series of ITU-R Reports

(Also available online at <http://www.itu.int/publ/R-REP/en>)

Series	Title
<b>BO</b>	Satellite delivery
<b>BR</b>	Recording for production, archival and play-out; film for television
<b>BS</b>	Broadcasting service (sound)
<b>BT</b>	<b>Broadcasting service (television)</b>
<b>F</b>	Fixed service
<b>M</b>	Mobile, radiodetermination, amateur and related satellite services
<b>P</b>	Radiowave propagation
<b>RA</b>	Radio astronomy
<b>RS</b>	Remote sensing systems
<b>SA</b>	Space applications and meteorology
<b>SF</b>	Frequency sharing and coordination between fixed-satellite and fixed service systems
<b>SM</b>	Spectrum management

*Note: This ITU-R Report was approved in English by the Study Group under the procedure detailed in Resolution ITU-R 1.*

*Electronic Publication  
Geneva, 2009*

© ITU 2009

All rights reserved. No part of this publication may be reproduced, by any means whatsoever, without written permission of ITU.

## REPORT ITU-R BT.2049-3

**Broadcasting of multimedia and data applications for mobile reception**

(Question ITU-R 45/6)

(2004-2005-2008-2009)

Appendix 1 – Launching of digital terrestrial sound broadcasting services in Japan.

Appendix 2 – Current Status of T-DMB Services and Advanced T-DMB.

Appendix 3 – The DVB-H Standard EN 302 304: Technology highlights commercial deployments.

Appendix 4 – Forward Link Only.

Appendix 5 – Digital mobile narrow-band multimedia broadcasting system AVIS (audiovisual information system).

Appendix 6 – Implementation of interactivity.

Appendix 7 – Acronyms.

## **1 Introduction**

The analogue-to-digital switchover of terrestrial broadcasting services is under way in all ITU Regions. Some countries have not yet taken a decision when to start, whilst other countries have already passed the 50% penetration level of digital TV reception within the household segment.

The development of in-vehicle entertainment systems based on stored content such as games, music and movies is about to reach its state of technology maturity.

IMT-2000 network offerings have begun to include on-demand streaming to handsets of TV-news, sports etc., and specifications within 3GPP/3GPP2 are well under way to include an optimized transport mechanism<sup>1</sup> for consumption of multimedia content via the IMT-2000 network and associated mobile radio spectrum in multicast mode.

The gap still not addressed at ITU level is the predicted large segment of digital broadcasting to handheld terminals via broadcast spectrum in a mobile environment including in-door, in-vehicle and in-transit reception at speeds matching at least IMT-2000 characteristics.

Broadcasting of multimedia and data applications to mobile devices will also elaborate the expanded service opportunities offered by the inclusion of interactivity through the application of wireless networks such as those of the IMT-2000 family.

These developments form the major background for Question ITU-R 45/6 with its request for a global view on this new market, which is about to emerge around a few major regional standards/specifications.

---

<sup>1</sup> 3GPP MBMS (Multimedia Broadcast Multicast Service); 3GPP2 BCMCS (Broadcast/Multicast Services).

This Report is a first attempt to answer Question ITU-R 45/6 on broadcasting multimedia and data applications for mobile reception. It identifies a number of application and system requirements for broadcasting of multimedia and data applications for mobile reception that encompass types of mobile receivers, the system characteristics, possible data transmission mechanisms, content formats, interoperability between telecommunication services and digital broadcasting services, and display patterns. It is recognized that these high-level application and system requirements may be met by a number of different technologies and communications platforms.

Several of the systems described in this Report have reached stages of maturity including the result of field trials and preliminary system specifications.

## 2 User requirements

Specific user requirements in the case of mobile reception of broadcasting multimedia and data arise because of the differences in receiving terminals and usage scenarios. In the following, specific user requirements are highlighted.

### 2.1 Types of receiving terminals

Currently the terminals used for the stationary reception of broadcasting signals are either fixed or nomadic. Fixed terminals are, for example, television sets, set-top-boxes, desktop PCs, etc. Nomadic terminals are devices that may be transferred from place to place but the reception is meant to be stationary. In the mobile reception there are two main types of terminals: handheld or mounted in a vehicle. Especially in the case of handheld devices the user requirements are very much different from the stationary case. The handheld devices have lower computing power, smaller screens, different user interface, smaller antenna, and limited battery for operation.

### 2.2 Types of usage scenarios

In the stationary reception the terminal and the user do not move, whilst in the mobile reception, both move.

*Case 1:* Neither user nor terminal move (nomadic case).

*Case 2:* User moves and carries the terminal (pedestrian case).

*Case 3:* Terminal and user are moved by a vehicle (vehicular case).

These three cases of mobility imply possible different usage scenarios, and consequently different end-user requirements.

### 2.3 Service requirements from ISDB<sup>2</sup> family use cases

Requirements for ISDB family, which has the plan to provide digital terrestrial sound broadcasting services, are shown at first. The following items are derived from typical service applications in this class of broadcasting system.

*Item 1:* For mobile receivers, informative contents will be provided by using streaming sound and associated data. There are three typical cases in this class. The first one is informative contents which provide practical and useful information of a specific geometric area or areas. The second one is broadcasting of traffic information including road traffic data and public transportation information. The third one is local news.

---

<sup>2</sup> ISDB family includes System C of Recommendation ITU-R BT.1306, System F of Recommendation ITU-R BS.1114 and ISDB-S of Recommendation ITU-R BO.1408.

*Item 2:* A streaming image (less than 15 frames/s in this case) is a distinctive programme in this broadcasting service. Two applications are considered, i.e. music programmes and live sport programmes. It is necessary to use medium-speed bit streaming, such as a few hundred bits per second, in order to broadcast a streaming image with associated sound and data. Because total bit rate per one terrestrial sound broadcasting service when using one frequency segment (500 kHz bandwidth) with most powerful error-correcting capabilities is about 280 kbit/s, this type of digital sound broadcasting systems can provide only one streaming image.

*Item 3:* For vehicular receivers, there are two major services. The first one is providing informative programme contents such as location-oriented information. The second one is real surround stereo sound services because car audio systems could provide real surround stereo sound effects more easily than home audio systems.

*Item 4:* For the fixed receivers, high-fidelity music programmes and informative contents are provided.

Analysing these requirements in the above, multimedia and data applications are very important even for audiences and/or viewers using mobile receivers. The requirements in this class are about the same as those for fixed receiver case while there are a few specifically different requirements between the mobile case and the fixed case. Multimedia and data applications for mobile reception would be a subset of those for fixed reception, however there are a few additional extensions designated specifically for mobile receptions.

Furthermore, these observations are almost true for the digital satellite sound broadcasting (BSS (sound)) system in Japan. Of course there are several differences in detailed parts between them due to the differences of their service areas, regional or national. However, we observe that the baseline requirements for broadcasting of multimedia and data applications are almost the same between them.

## **2.4 Service requirements for DVB-H use cases**

IP-based services delivery over DVB-H (Digital video broadcast – handheld) typically consists of an end-to-end content delivery system with both a terrestrial DVB-H broadcast part and a bidirectional mobile cellular (2G/3G) part.

The service requirements (in the European market) for broadcast of digital content to mobile handheld devices are dominantly driven by the idea to deploy synergies with the broadcast and mobile cellular networks. The broadcast channel is best suited for delivery of several parallel<sup>3</sup>, (real-time) scheduled services (e.g. TV channels) for large audiences in wide area coverage. Cellular channel can be best utilized for personalized point-to-point services and offering the interactivity between the consumer and the IP-based services delivery system. The complementary nature of the system is also a basis for more versatile and new services that would not be possible without this synergy.

Expected IP-based services offering will develop from the existing broadcast service offering (TV programmes) towards more versatile interactive services.

---

<sup>3</sup> The system's capability to provide multiple service (TV) channels in parallel is based on the lower bandwidth requirements of small screen size terminals per service channel compared to large-screen TV. For example, a DVB-H broadcast carrier with capacity of 10 Mbit/s could deliver 50 TV channels of 200 kbit/s each for mobile broadcast reception.

A typical terminal used with the IP-based services delivery system over DVB-H combines digital multimedia broadcast receiving capability with mobile phone terminal functionality. Mobile phone terminals have many physical limitations. Taking into consideration the specific characteristics of handheld terminals, service requirements for this system are provided below.

#### **2.4.1 The Electronic Service Guide (ESG)**

In the mobile environment it is especially important for the user to be able to navigate through the various broadcast service offerings in an easy and formalized way. The Electronic Service Guide (ESG) contains information of the available services and how those can be accessed. The concept of the ESG has been found to be a well-accepted way for the user on the move to discover, select, and purchase the broadcasted services he/she is interested in.

#### **2.4.2 Mobile TV**

Mobile TV services consist of traditional TV programmes or TV-like programmes. TV type of services presented to mobile handheld devices with small screens is predicted to be designed different from content offered to large screen receiving terminals in a stationary broadcasting environment.

Instead of users watching a two-hour movie on the smaller screen of a handheld terminal, a more typical usage scenario would be to watch news flashes, sports features, music videos, weather forecasts, stock exchange reports and other such content, which is suitable for “ad hoc” consumption during smaller time slots.

The mobile TV programmes may be supplemented by auxiliary data associated with the basic service. Such information could be part of the broadcast or can be accessed on demand via the interactivity link, which is described in § 2.4.9.1.

The additional background information may include links to the service provider’s web pages, video clips, sound tracks, games, etc.

#### **2.4.3 Enhanced mobile TV**

Online TV shopping, chat, gaming and quiz plus voting are examples of functionalities, which may be introduced as enhancements to the mobile TV to allow a true interactive mobile broadcasting<sup>4</sup> experience.

#### **2.4.4 Scheduled download of audiovisual content or executable software modules**

Within this category of services, the terminal receives and stores scheduled (information via the ESG) downloads of media files or any other kind of digital data files for later consumption (video clips, newspapers, games, maps, etc.). Broadcasting offers an efficient way to deliver such downloads to a large audience throughout a wider area.

#### **2.4.5 Service purchase, service access and content protection**

Some stationary broadcast systems today offer pay-per-view facilities. A fundamental requirement foreseen for the mobile broadcasting segment is that the system has to support purchase and charging of broadcasted content.

Both subscription and pay-per-view-type online purchase models for services are foreseen to become more lucrative than consumption of free-to-air content only.

---

<sup>4</sup> In this Report, the term “mobile broadcast/mobile broadcasting” is used to convey the concept of delivery of broadcast programmes for mobile reception.

Service purchase and delivery of service access rights may in a simple way be realized by the applied mobile telephone two-way connection. Standardized service access and content protection is a prerequisite to obtain inter-operable solutions and for users to access payable broadcast services also in the case of global roaming.

#### **2.4.6 Roaming**

A user requirement associated with the mobile environment only is the ability to access services even outside the home network, and the solution to this is to establish mechanisms that allow users to access broadcast content even outside national or regional territory.

Roaming has proven to be maybe the most important of all basic mobile system characteristics. The swift implementation of roaming within mobile telephone networks has in the past proven to be a major contributor to the overall success of mobile telephony worldwide.

In this context, the mobile broadcasting service offerings will be no exception. Mobile broadcasting networks will have to offer ways to support mobile broadcasting terminals outside their primary service areas.

It seems obvious that the application of roaming capable mobile telephony technologies within mobile broadcasting systems may bring broadcast roaming to a reality at a much faster pace.

#### **2.4.7 Interference free reception in the mobile environment**

Having been experiencing for many years the quality of service (QoS) of stationary (analogue) terrestrial broadcasting, future users of mobile broadcasting services will not only demand a higher level of QoS (clearer TV pictures, higher sound quality) but also demand, that this is sustained in the mobile environment, where multipath-reflections and Doppler-shifts introduce substantial BER in the broadcasted data stream.

Here it is important to note, that these systems will not only be used to receive broadcast content in the traditional sense, but also be capable of offering error free downloads of purchased source code and even executable code, which of course has to reach the target clients uncorrupted.

The practical implementation of mitigating such interference is not trivial, but has already found different solutions in some of the new standards/specifications emerging.

#### **2.4.8 Long battery lives**

Compared to stationary reception of broadcasting, the mobile broadcast receiver is introducing this new user requirement, which can only be met if the broadcasting link system allows for low power consumption of the receiving handheld terminals.

#### **2.4.9 Implementation of interactivity**

An interactive environment for users of mobile services has today become a basic requirement.

Short message services form part of major core digital mobile standards and email facilities along with web browsing are found even in legacy handheld mobile telephone terminals.

Such facilities cannot easily be made available to users of stationary terrestrial broadcasting receivers until the terrestrial radio broadcasting delivery networks have been digitized along with stationary receivers.

It is therefore natural for the mobile user community to expect interactivity as a basic characteristic of future mobile broadcasting services, an expectation that market studies and commercial operator requirements have confirmed.

### 2.4.9.1 Digital mobile telephony

As the major part of the world standards of digital mobile telephony including IMT-2000 offer two-way data services, one approach to implement interactivity seem to be the incorporation of such mobile technology in the user terminals.

Apart from offering the user all state-of-the-art mobile telephone services, this way of implementation of interactivity with the broadcasting service offerings provide immediately a reliable control link for all such broadcasting services. It allows the user to respond and interact with the broadcasting system and to receive control codes through a secure environment.

This approach may also take advantage of the global roaming characteristics of many mobile technologies as well as of the wide-area coverage characteristics of mobile telephone technology throughout the world.

Further information is provided in Appendix 6.

## 2.5 Service requirements for T-DMB<sup>5</sup> use cases

The Digital Sound Broadcasting (DSB) system was originally designed to provide high quality audio services. It is also pursued to provide multimedia services including video and interactive data services for mobile reception. Mobile multimedia service has been developed based on the DSB System A in Korea, which is named as Terrestrial Digital Multimedia Broadcasting (T-DMB).

In order to accomplish the purpose of multimedia broadcasting for mobile reception, some of the additional key requirements are as follows:

### 2.5.1 General requirements

- complete backward compatibility with the DSB System A;
  - robust reception of video in mobile environments at the speed of up to 200 km/h;
  - power-up delay no greater than 2 s.
- (NOTE – The delay does not include start-up time of the operating system in a receiver.)
- delay of audio objects relative to the corresponding video objects in the range of –20 ~ +40 ms;
  - delay of auxiliary data relative to the corresponding video objects in the range of –300 ~ + 300 ms;
  - RF channel change delay not exceeding 1.5 s.

(NOTE – When the programme is changed within the same ensemble, the delay shall not exceed 1 s.)

### 2.5.2 Video objects

- video quality comparable to VCD on 7-inch display devices;
- display resolution up to 352 × 288;
- frame rates up to 30 frames/s;
- random access period no greater than 2 s.

---

<sup>5</sup> T-DMB is a new subsystem of DAB (Recommendation ITU-R BS.1114 System A/Eureka 147), which makes use of DAB sub-channel for MPEG-2 Transport Stream. This system is identified as TTAS.KO-07.0026 in Korea.



### 2.5.3 Audio objects associated with the video

- audio with the maximum sampling rate of 48 kHz;
- audio quality up to CD-quality;
- random access period no greater than 50 ms.

### 2.5.4 Auxiliary data (optional)

- supplemental information shall be provided;
- interactive services shall be provided;
- random access period shall be no greater than 0.5 s.

## 2.6 Service requirements for Forward Link Only (FLO) use cases

The FLO technology is designed specifically for mobile applications and for wireless multimedia services. It has been optimized for the efficient simultaneous distribution of multimedia content to multiple users while addressing the physical limitations of the terminal, including power consumption, memory and form-factor constraints as well as its more constrained receiving conditions (lower height, indoor pedestrian, etc.).

Key requirements for a physical layer design for terrestrial broadcasting of multimedia and data applications for mobile reception include the following:

- Meet or exceed consumer demands for mobile multimedia services such as:
  - Good indoor coverage.
  - High-quality viewing experience.
  - Local news, weather and sports.
  - National and regional programming.
  - Quality of service for all data types.
- Support for streaming audio and video.
- Low-cost, low-power consumption mobile devices.
- Efficient transmission characteristics.
- Cost-effective infrastructure.
- Ability to simultaneously use normal phone functionality.
- Secured and controlled access to multimedia services controlled (via conditional access protocols, which apply cryptography techniques to prevent unauthorized access). Flexible service subscription on a per package basis via the cellular device or other IP connection.
- Ability to support additional public safety, disaster relief, education, e-government or public service applications.

### Required service types include:

- *Real-time multimedia*: real-time multimedia is functionally equivalent to conventional television or radio service. The media is consumed as it is delivered.
- *Non-Real-time*: non-real-time is any type of content that is delivered as a file and stored. This type of delivery allows users to consume media at their convenience. The specific media type of the file is relatively unimportant to the physical layer.

- *IP datacasting*: IP datacast supports any application on the handheld devices with an IP interface. The generic nature of IP to some degree limits the performance gains possible by matching the data type to the delivery mechanism, but an IP interface is convenient for the using application.
- *Interactive Services*: any of the service types described above may incorporate interactivity that utilizes the unicast capability of a handheld receiver. Additionally, some of the more common interactive functions may be supported directly on the device via stored files delivered via broadcast.

### **Quality of service**

Each of the service types described above has slightly different QoS requirements. Real-time services require fast channel change and rapid recovery from brief channel outages. File delivery-based services need mechanisms to recover from the impact of similar fading and other channel outages, but are not constrained by rapid acquisition requirements i.e. quick programme channel changes or recovery from signal loss. The entire file is received and stored prior to consumption. IP-delivered services appear as a hybrid of the real time and file delivery types. However, if file delivery is achieved via other non-real time delivery mechanisms, the IP services share much of the characteristics of real time, e.g. an IP delivered “stock ticker” is a real-time service with a slightly less stringent time delivery deadline.

### **Audio and video support**

Audio and video are required media types.

### **Functionality, cost, power consumption**

The basic mobile device function and cost should not be significantly impacted by the addition of the new physical layer. The normal phone functions should not be obstructed by the mobile multimedia functionality.

## **3 Types of mobile receivers**

This section provides several types of receiver for mobile reception with comparison to fixed reception. In the mobile reception there are three main types of terminals: nomadic, pedestrian and vehicular terminals. Especially in the case of handheld devices for pedestrian case, the user requirements are very much different from the fixed case.

### **3.1 Nomadic receivers**

Nomadic receivers are devices that may be transferred from place to place but the reception is meant to be stationary.

Nomadic reception means that receivers are used in fixed position while the receivers can be carried easily in a nomadic receiver case. Figure 1 shows an example of nomadic receivers.

*Nomadic receivers:* TV/radio/CD combo, lap-top-PC  
Use indoor antenna, may be operated using battery power.

FIGURE 1

An example of prototype nomadic receivers



Rap 2049-01

### 3.2 Pedestrian receivers

Pedestrian devices have several physical limitations, for example, weight, size, computing power, battery capacity, etc. These limitations imply two types of devices.

*Basic handheld receivers:* Pocket radio with limited display capability (see Fig. 2a)), mobile phone like (see Fig. 2b))

*Enhanced handheld receivers:* PDA like (see Fig. 2c))

These terminals have lower computing power, smaller screens, different user interface, smaller antenna, and limited battery for operation.

FIGURE 2

Several types of handheld receivers

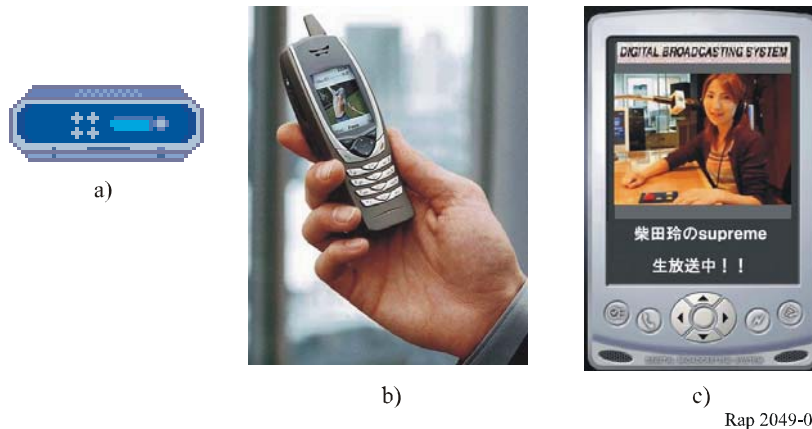

Rap 2049-02

### 3.3 Vehicular receivers

This type of device has less physical limitations than pedestrian cases however the moving speed is much higher than pedestrian reception.

*Vehicular receivers:* Car radio/CD with limited display capability

Car navigation combo with 6.5/7-inch full colour screen.

Vehicular receivers would require sophisticated man-machine interface for operation. There may be many restrictions when the transmitted contents are displayed to vehicular driver.

### 3.4 Vehicular reception using nomadic and pedestrian receivers

In some cases, nomadic and/or pedestrian devices are used in fast-moving transportation equipment, such as cars and trains. In this case, nomadic devices and pedestrian devices are required to receive the signals under more severe receiving conditions.

### 3.5 An example of enhanced handheld receivers

Figure 3 shows an experimental model of a digital BSS (sound) receiver in Japan. The size of this receiver is 75 mm (H) × 112 mm (W) × 22 mm (D). Weight is about 200 g including a battery. It has a 3.5-inch diagonal LCD screen for data- and video-broadcasting services.

This receiver model makes use of the second-generation chip set for this digital satellite broadcasting system.

FIGURE 3

An example of enhanced handheld receivers for digital BSS (sound)



Rap 2049-03

## 4 System characteristics and network planning aspects

On a system level there are several characteristics that are required for broadcasting multimedia and data applications for mobile reception. Again, the requirements are best explained in comparison to fixed reception.

### 4.1 Distribution network

Mobile and handheld reception of broadcast signals necessitates consideration of limitations inherent to the receiving devices. Mobile and handheld devices will have small antennas, which require that the broadcast signal be stronger than that used in typical above-rooftop receiver configurations, in particular to achieve indoor coverage. Whenever available, the use of broadcasting Bands III, IV and V together with the use of higher emission power and antenna heights than traditional cellular networks, results in greater coverage per transmitting site and lower per-bit delivery cost. In addition, the radio transmission parameters and signalling protocol methodology may need to be modified to support mobile reception, such that the effects of multipath reflections and Doppler shifts can be effectively mitigated, and to compensate for the

expectation that the receiving power level and signal quality reaching the mobile antennas may be far less than that feeding the fixed receivers (which are often serviced by a fixed outdoor directional (Yagi) antenna).

There are different ways to optimize the broadcasting link budget: either to increase the transmitting power or have a denser transmission network. Depending on the national market sizes and the regulatory environment, both approaches could be envisioned but increasing the transmitting power may efficiently improve the link budget in country where the interference environment and the regulatory rules are favourable. In other regions of the world, this approach may complicate the network planning both nationally as well as on the international level due to cross-border frequency coordination and multiple frequency implementations of traditional broadcasting networks. In these cases the optimal approach to an efficient distribution network for mobile reception seems to be the establishment of a low power, smaller footprint type of transmitter grid. This approach will also allow for a higher degree of frequency reuse, in particular in the new digital broadcasting domain.

#### 4.2 Some network planning and radio frequency aspects

The work on the coordinated introduction of digital broadcasting in the current analogue bands is indeed very complex and requires careful consideration of all aspects, which may have impact on the planning methodologies being considered and finally adopted.

As Fig. 4 illustrates, the low power single frequency network (SFN) is a victim of interference from a neighbouring transmitter operating a different multiplex on the same broadcast channel.

By the introduction of low power broadcasting an allotment plan should be considered to ensure equal treatment of all broadcasting services including the broadcasting distribution networks optimized for mobile and handheld reception.

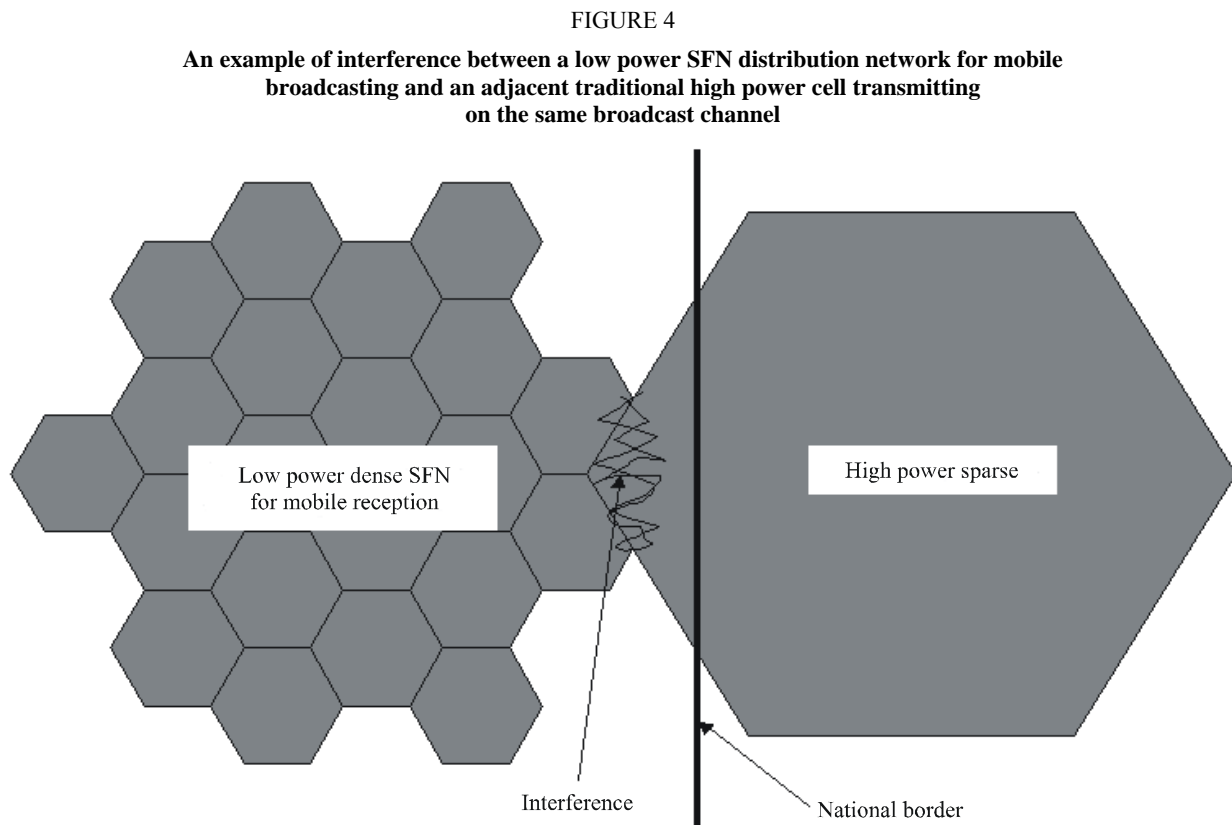

One administration has adopted technical and service rules for the upper UHF bands, which enable the most efficient delivery of multimedia services using higher emission power and antenna heights than traditional cellular networks and national single frequency network configuration. However these rules did not specify the type of technology and/or services to be deployed in these bands did address interference issues between licensees. This results in greater coverage per transmitting site and lower per-bit delivery cost. In markets where similar spectrum and power limits are available, the FLO technology is a suitable option for mobile multimedia broadcast solutions.

#### **4.3 Receiver characteristics**

In comparison to fixed reception there are several elements in the receiver characteristics that are affected by specific requirements of the mobile reception. These specific requirements are especially relevant for the above-mentioned cases of mobile reception. First, reasonable size for receiver antenna is in the order of a few centimetres compared to large aeriels of current fixed terminals. Second, mobile receivers use non-directional antennas which imply a loss in the antenna gain as opposed to fixed directional antenna. Third, the displays of these terminals are likely to be much smaller than traditional fixed terminal like television. Fourth, the operating time of pedestrian terminal is limited by the battery capacity. Last, there may be differences in radio receiver and signal processing required to support time-varying channel and interference conditions.

#### **4.4 Content manipulation and distribution**

Currently, the content encoding, encapsulation and distribution systems are required to process mainly audio/video content and supplementary data that is related to enhanced broadcast services. Similar requirements have been stated for the receiving system that performs content decoding, processing and display. Considering mobile reception of multimedia and data applications, those systems need to allow and support encoding/decoding, encapsulation, processing and distribution of arbitrary data, end to end.

#### **4.5 Managing mobility**

Due to user mobility and possibly limited coverage of a single broadcasting signal, the transmitting end has to facilitate end users' hand over (for example, through some kind of announcement signalling) in the case of multi-frequency networking. The receiving end has to be aware of possible loss of signal during the reception and react in a feasible manner if that happens.

In the case of single frequency networking, suitable transmission parameters should be selected for this purpose.

#### **4.6 Error characteristics**

Comparing fixed and mobile receptions of multimedia and data applications, there are differences in channel error characteristics. The transmitting end may need to make the transmission more robust by using, for example, forward error correction (FEC) techniques and/or deeper time domain interleaving. The receiving end has to be aware of possible loss of data. Further, the severity of the loss of fragments of data has different impact on user experience. For example reception of audio/video stream is more tolerant to partial data loss than reception of a data file.

#### **4.7 Interoperability between mobile telecommunication services and digital broadcasting services**

This issue should be approached by defining clear levels or parts of total system and service functionality for which we envisage interoperability. Two main levels are interoperable on content format level and interoperability on service level.

For interoperability on content format level the approach could be the following. First, given the inherent limitations of mobile devices such as display sizes, processing power, battery life, etc., content formats used in mobile telecommunication systems, should be optimized in order to design the appropriate systems. Then it is necessary to list the existing and planned content formats used in (interactive) broadcasting systems. Last, the content formats should be based on the considerations mentioned above.

The interoperability on service level remains a topic that is constantly being reviewed.

## 5 Transmission mechanisms for broadcasting of multimedia and data applications for mobile reception

Several types of transmission mechanisms are proposed for this purpose; ARIB STD-B24, T-DMB, DVB-H, and FLO are possible candidates.

There are several methods for so called “encapsulation” using either MPEG-2 TS, IP-Packets, or other generic packet data methodologies.

In Table 1, an overview of currently known mobile broadcasting transmission mechanisms is provided. The technical characteristics shown are subject to change and are by no means exhaustive but provided for comparison only.

TABLE 1  
Summary of mobile digital broadcasting transport mechanisms

Standard or Specification	Modulation	Transport stream	RF channel (MUX) size From technical view point (MHz)	International broadcast bands	Receiver power reduction methodology
ISDB-T	QPSK or 16/64-QAM OFDM	MPEG-2 TS	0.429 or $3 \times 0.429$	IV and V	One/three segment(s) reception
Digital System E	QPSK CDM	MPEG-2 TS	25	2.6 GHz in Region 3. Satellite link plus terrestrial augmentation	Optimized receptions of CDM codes
T-DMB	DQPSK COFDM	MPEG-2 TS	1.5	III, 1.5 GHz	Originally optimized bandwidth
DVB-T	QPSK or 16-QAM COFDM	MPEG-2 TS	6, 7, 8	IV and V	For vehicular receivers
DVB-H	QPSK or 16-QAM COFDM	IP/MPE-FEC/ MPEG-2 TS	5, 6, 7, 8	IV and V	Time slicing
FLO	QPSK or 16-QAM COFDM	Generic packet data	5, 6, 7, or 8	IV and V	Time slicing

Further technical details are provided in the Appendices.

## 5.1 ARIB STD-B24

### 5.1.1 Current multimedia and data transmission system

ARIB STD-B24 would allow the creation of content for digital broadcasting in a mobile environment, as such, it is a possible candidate system specification for transmission of multimedia and data over a broadcasting channel to handheld and vehicular receivers. A layered protocol stack for ARIB STD-B24 is shown in Fig. 5. This protocol stack is applied to all systems of the ISDB family including Digital System E<sup>6</sup> for the hybrid broadcasting system. The text for ARIB STD-B24 is available on the ARIB website: <http://www.arib.or.jp/english/html/overview/archives/br.html>. Annexes 4 and 5 to ARIB STD-24 Part 2 are relevant to this subject.

FIGURE 5  
Protocol stack for ARIB STD-B24

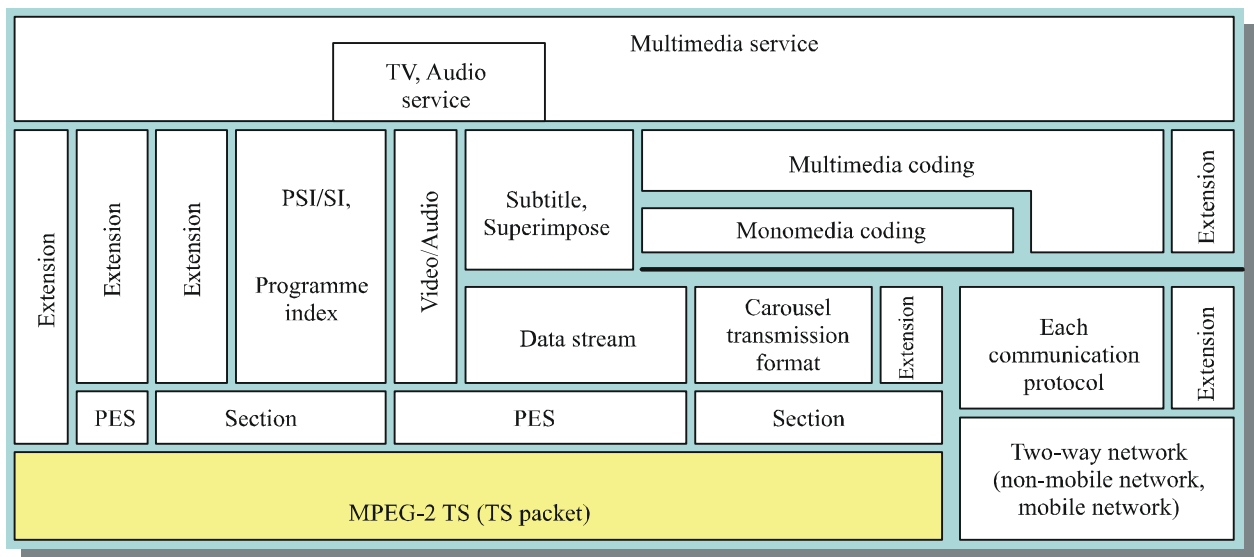

Rap 2049-05

In order to fulfil the specific requirements especially for mobile reception, some extensions are added for this purpose.

In ARIB STD-B24, mobile receptions are divided into two parts depending on the type of receivers, basic handheld receivers and enhanced handheld (including vehicular) receivers. Annexes 4 and 5 to Part 2 of ARIB STD-B24 provide the specifications for basic handheld receivers, and enhanced handheld receivers and vehicular receivers, respectively.

Question ITU-R 45/6 refers the only one technical term “mobile reception” in its title however it is better to use both handheld receivers and vehicular receivers when we consider the difference of physical implementation of digital broadcasting receivers.

<sup>6</sup> Digital System E is recommended in Recommendations ITU-R BO.1130 and ITU-R BS.1547.

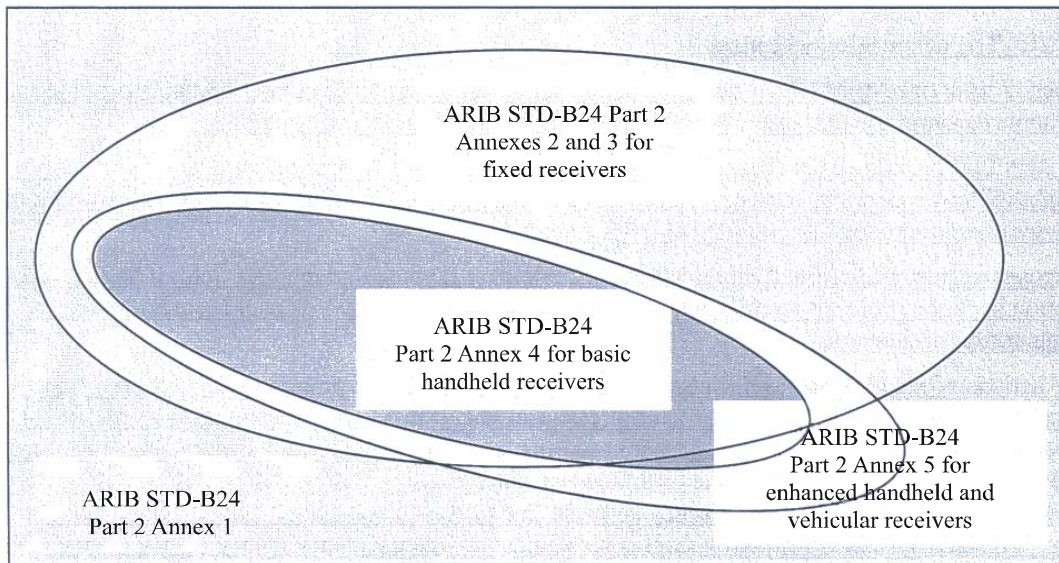

Figure 6 explains the interrelations between three types of digital receivers, i.e. handheld, vehicular and fixed receivers for categorizing the specifications for broadcasting of multimedia and data applications. As indicated in Fig. 5, ARIB STD-B24 is the typical example for MPEG-2 TS encapsulation.

Table 2 provides the list of applicable ARIB standards and technical reports for the ISDB family and interoperability among these systems. Mobile broadcasting systems are also completely embedded in the ISDB family.

FIGURE 6

**Interrelations between fixed, handheld and vehicular receivers in the aspect of broadcasting of multimedia and data applications in ARIB STD-B24**



Rap 2049-06

TABLE 2

**Applicable ARIB STDs/TRs for the ISDB family and interoperability among these systems**

	BS (ISDB-S) / CS 110	Terrestrial television (ISDB-T)	Terrestrial sound (ISDB-TSB)	Satellite sound using 2.6 GHz (Digital System E/MSB)
Physical layer	STD-B20	STD-B31	STD-B29	STD-B41
Service multiplexing	STD-B10 and STD-B32 (part)			
Video/audio coding	STD-B32 (Audio and Video)		STD-B32 (Audio)	
Multimedia broadcasting	STD-B24 including video streaming			
	Annex 2	Annex 3	Annex 4	Annex 5
Access control	STD-B25			
Receivers	STD-B21		STD-B30	STD-B42
Operational guidelines	TR-B15	TR-B14	TR-B13	TR-B26

STD: Standards      TR: Technical Report

**5.1.2 Experimental data transmission mechanisms for mobile reception**

It is important for mobile reception cases to cope with relatively worse receiving conditions than the fixed reception cases. Especially, data broadcasting receptions in relatively worse receiving conditions need longer acquisition time than the error-free reception cases due to the characteristics of the applied retransmission mechanisms.

**5.1.2.1 The carousel mechanism**

When at least one MPEG-2 TS packet has at least one bit error, all MPEG-2 TS packets related to the same carousel are discarded by current carousel data transmission protocols.

All MPEG-2 packets are protected by Reed-Solomon code with 8-byte forward-error-correcting capability however errors may be detected by CRC in MPEG-2 TS Section type packet if more than 8-bytes errors are added to one MPEG-2 TS packet.

The proposed system adds an individual MPEG-2 TS Packet ID in the adaptation field of MPEG-2 TS Section packet in order to identify which packets are error free or which packets are affected by transmission data errors.

The actions of the first carousel transmission period of the current and proposed systems are almost the same, however the second period or later of the carousel data transmission period are quite different between those two systems. At the beginning of the second period, the current system simply discards all MPEG-2 TS packets if there is at least one error packet using CRC error-detecting capability. On the contrary, the proposed system keeps all error-free packets but discards error-detected packet only. The proposed system fills up all vacant parts with error-free packets from the second or later carousel cycles.

Figure 7 shows where the MPEG-2 TS Packet ID is implemented. Table 3 gives the syntax for MPEG-2 TS Packet ID.

FIGURE 7  
Proposed modification to add packet ID using 8 bytes in a private data field

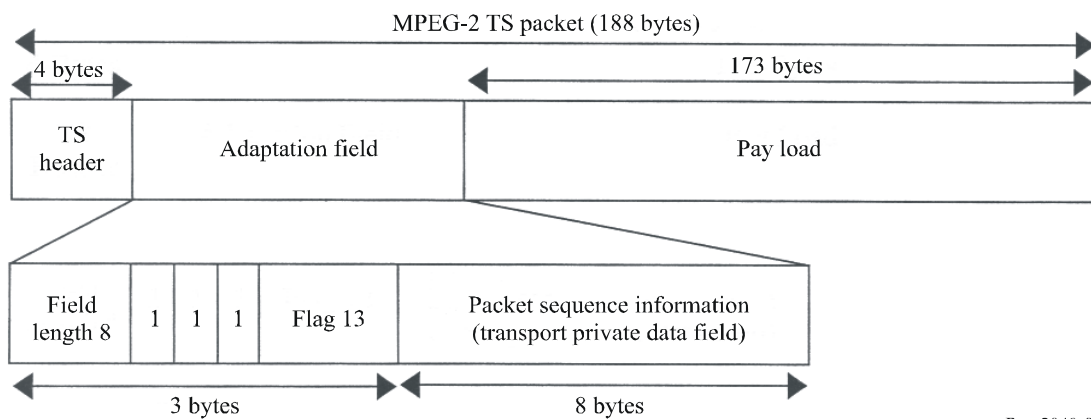

TABLE 3  
Additional data descriptions for TS Packet ID

Syntax	The number of bits	Mnemonic
Private_data_byte () { Private_data_type If(Private_data_type==1){ Table_id Table_id_extension Version_number Section_number Last_section_number TS_Packet_Number Last_TS_packet_number Reserved	8  8 16 5 8 8 5 5 1	uimsbf  uimsbf uimsbf uimsbf uimsbf uimsbf uimsbf uimsbf bslbf

Further information is provided in Appendix 1.

## 5.2 IP-based services delivery over DVB-H

### 5.2.1 IP as a content bearer for the broadcasted data

One of the ways to carry content to mobile terminals could be to broadcast content in the form of IP encapsulated data packets on top of the actual broadcast (radio) bearer. This is in order to facilitate maximum efficiency in the establishment of inter-working with the Internet and other systems deploying IP and to make maximum use of the substantial number of existing transmission and security methodologies based on the IP protocol.

This means that, in principle, any kind of IP-based content could be made available to users through the mobile broadcast system.

Another characteristic of an IP-based service delivery system is, that it is to a great extent network agnostic (see Fig. 8) allowing service providers and network operators the freedom to choose the best-suited distribution path for the content and services.

FIGURE 8  
Internet Protocol and related protocols provide a common platform for multimedia and data broadcasting

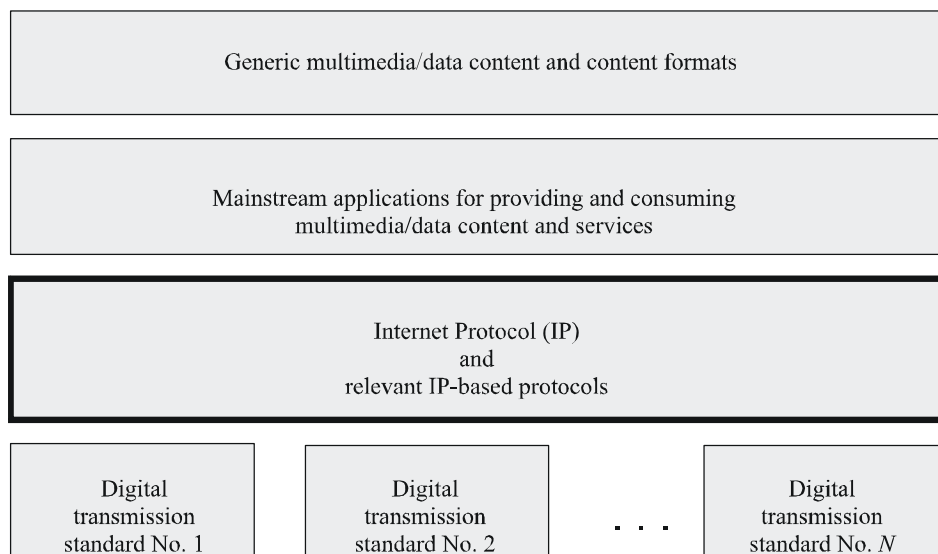

### 5.2.2 Content formats

Content formats should be generic and scalable. By generality of content formats it is meant that any suitable content available in the Internet or through any other system should be supported when considering broadcasting multimedia and data applications for mobile reception. By scalability, content formats allow scaling for different levels of processing power and for different sizes of screen.

Especially useful are content formats that are resilient towards transmission errors and that utilize content encoding that is efficient in terms of used bandwidth.

Content formats should be harmonized as far as possible with the current work of different broadcasting systems and well as with the IMT-2000 systems and other wireless systems.

The content formats are needed for the reception of audiovisual content as a direct view (real-time) or as a download (scheduled) as well as for other downloadable (scheduled) content like software modules aimed at gaming, maps, newspapers and other data files according to market demands.

In terms of media types the content formats are needed for: audio (sampled and synthesized); video; still images; bitmap graphics; text (unstructured, structured, hypertext), and supported generic binary objects.

Further information is provided in Appendix 3.

## 5.3 Transmission mechanisms of T-DMB

### 5.3.1 System architecture

The system for the T-DMB video services has the architecture that transmits MPEG-4 contents encapsulated using “MPEG-4 over MPEG-2 TS” specification as illustrated in Fig. 9.

Video service is delivered through the stream mode of DSB System A transmission mechanism. In order to maintain extremely low bit error rates, this service uses the error protection mechanism described in § 5.3.5. This video service is composed of three layers: contents compression layer, synchronization layer, and transport layer. In the contents compression layer in § 5.3.6, ITU-T H.264 | ISO/IEC 14496-10 AVC is employed for video compression, ISO/IEC 14496-3 ER-BSAC for audio compression, and ISO/IEC 14496-1 BIFS for auxiliary interactive data services.

To synchronize audio-visual contents both temporally and spatially, ISO/IEC 14496-1 SL is employed in the synchronization layer. In the transport layer specified in § 5.3.4 some appropriate restrictions are employed for the multiplexing of compressed audiovisual data.

### 5.3.2 Video service transmission architecture

The conceptual transmission architecture for video services is shown in Fig. 10. The video, audio, and auxiliary data information for a video service are multiplexed into an MPEG-2 TS and further outer-coded by the video multiplexer. It is transmitted by using the stream mode specified in DSB System A. The video multiplexer is described in § 5.3.3.

FIGURE 9  
 Conceptual architecture for the video services

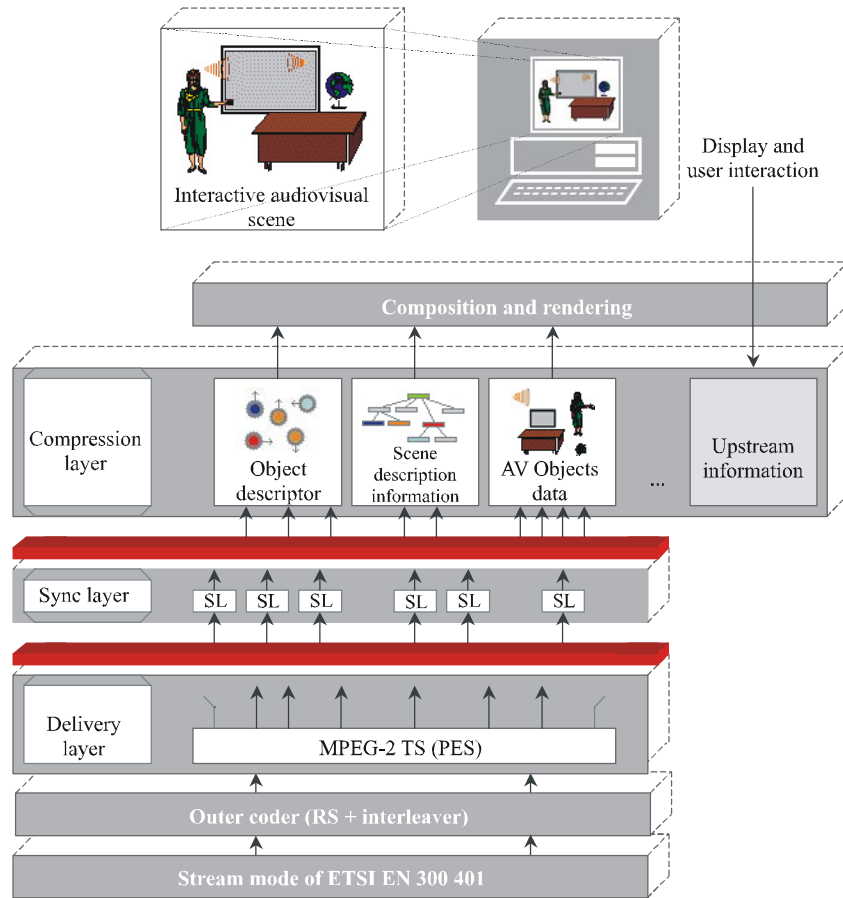
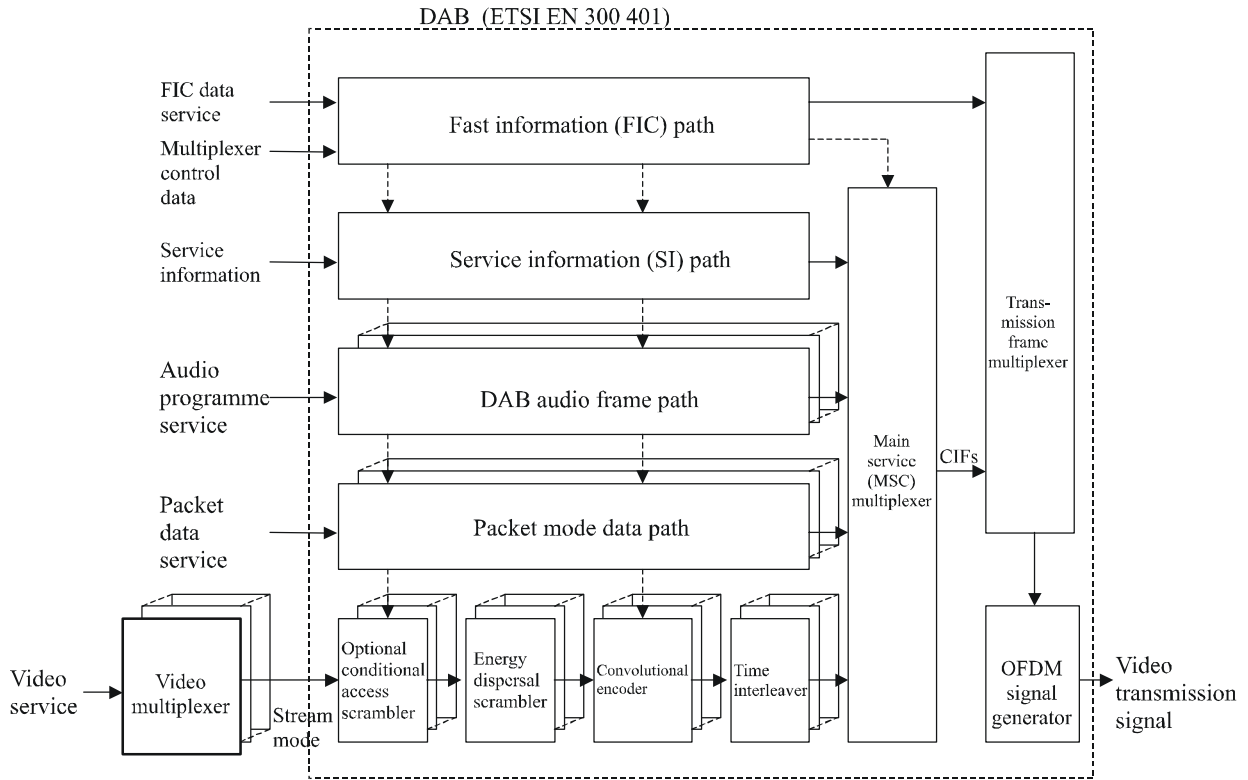

FIGURE 10

Conceptual transmission architecture for the video services



### 5.3.3 Video multiplexer architecture

The conceptual architecture of the video multiplexer for a video service is shown in Fig. 11.

FIGURE 11

Architecture of the video multiplexer

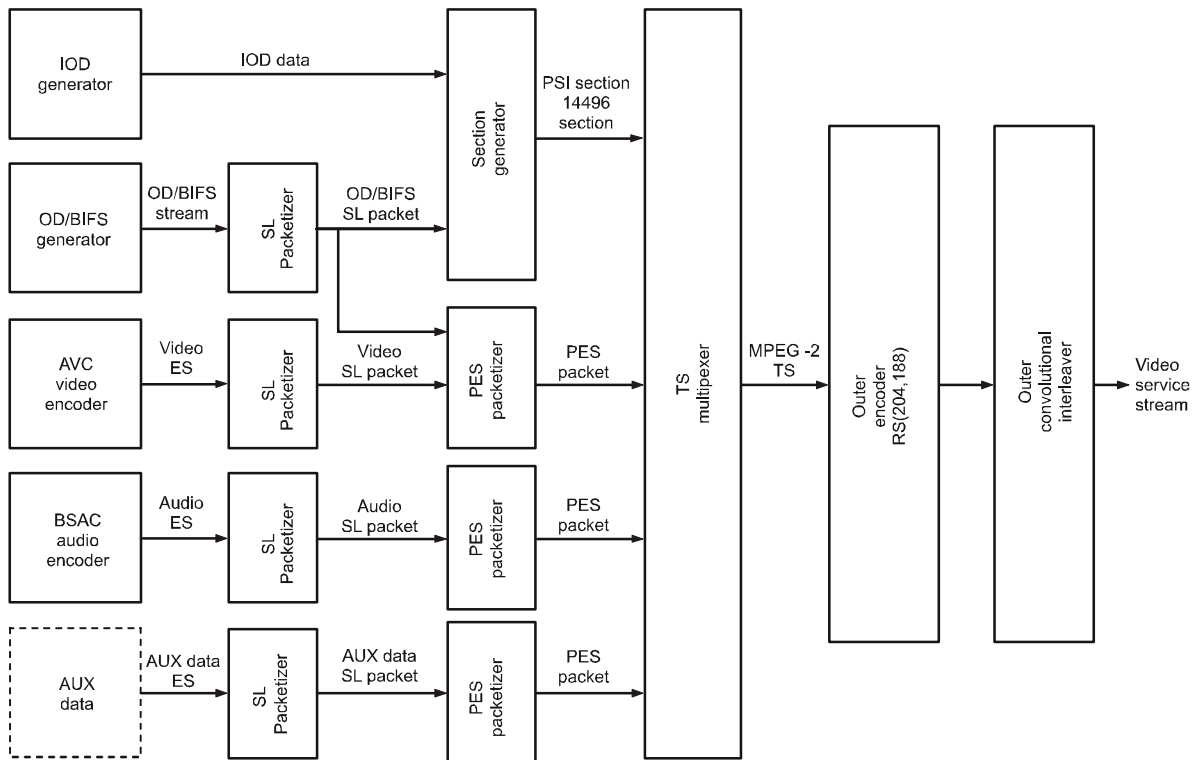

Rap 2049-11

- The IOD generator creates IODs that comply with the ISO/IEC 14496-1 Standard.
- The OD/BIFS generator creates OD/BIFS streams that comply with the ISO/IEC 14496-1 Standard.
- The video encoder generates an encoded bit stream compliant with the ITU-T H.264/AVC standard by performing data compression processing of the input video signal.
- The audio encoder generates an encoded bit stream compliant with the ISO/IEC 14496-3 ER-BSAC Standard by performing data compression processing of the input audio signal.
- Each SL packetizer generates an SL packetized stream compliant with the ISO/IEC 14496-1 System Standard for each input media stream.
- The section generator (PSI generator) creates sections compliant with the ISO/IEC 13818-1 Standard for the input IOD/OD/BIFS.
- Each PES packetizer generates a PES packet stream compliant with the ISO/IEC 13818-1 Standard for each SL packet stream.
- The TS multiplexer combines the input sections and PES packet streams into a single MPEG-2 TS compliant with the ISO/IEC 13818-1 Standard.
- The outer encoder attaches additional data, generated by using the RS code for error correction, to each packet in the MPEG-2 TS multiplexed data stream.
- The outer-coded data stream is interleaved by the outer interleaver, which is a convolutional interleaver (refer to § 5.3.5), and is output as a video service stream.

### 5.3.4 Transport stream specification

The transport stream layer plays the role of multiplexing video, audio, and auxiliary data for a single programme. It does not support the conditional access scheme defined in the ISO/IEC 13818-1<sup>7</sup> Standard. PCR is used for system synchronization.

The ISO/IEC 14496-1 MPEG-4 System layer provides synchronization among ESs using OCR, CTS, and DTS together with the PCR described above. In addition, the layer provides linkage among ESs that constitute a video service, and uses scene description information for the composition of a video service. It uses the SL packetization, but does not utilize the FlexMux multiplexing.

#### 5.3.4.1 Transport stream packet specification

A TS packet shall have the structure shown in Table 4<sup>8</sup>.

TABLE 4  
Structure of a TS packet

Syntax	Number of bits	Restrictions
<pre> Transport_packet(){   Sync_byte   Transport_error_indicator   payload_unit_start_indicator   Transport_priority   PID   Transport_scrambling_control   adaptation_field_control   continuity_counter   if(adaptation_field_control == '10'    adaptation_field_control == '11'){     adaptation_field()   }   if(adaptation_field_control == '01'    adaptation_field_control == '11') {     for (i=0; i&lt;N; i++){       Data_byte     }   } } </pre>	<p>8</p> <p>1</p> <p>1</p> <p>1</p> <p>13</p> <p>2</p> <p>2</p> <p>4</p> <p>8</p>	<p>'00'</p>

<sup>7</sup> Among PSI, CAT is not used.

<sup>8</sup> In the Table, restrictions are described only when they are to be imposed.



The adaptation field within a TS packet shall have the structure shown in Table 5.

TABLE 5  
Structure of the adaptation field of a TS packet

Syntax	Number of bits	Restrictions
<pre> adaptation_field() {   adaptation_field_length   if (adaptation_field_length&gt;0) {     Discontinuity_indicator     random_access_indicator     elementary_stream_priority_indicator     PCR_flag     OPCR_flag     splicing_point_flag     transport_private_data_flag     adaptation_field_extension_flag     if (PCR_flag == '1') {       program_clock_reference_base       Reserved       program_clock_reference_extension     }   } } </pre>	<p>8</p> <p>1</p> <p>1</p> <p>1</p> <p>1</p> <p>1</p> <p>1</p> <p>1</p> <p>1</p> <p>33</p> <p>6</p> <p>9</p>	<p>'0'</p> <p>'0'</p>
<pre> if (OPCR_flag == '1') { } </pre>		not used
<pre> if (splicing_point_flag == '1') {   splice_countdown } if (transport_private_data_flag == '1') {   transport_private_data_length   for (i=0; i&lt;transport_private_data_length; i++) {     Private_data_byte   } } </pre>	<p>8</p> <p>8</p> <p>8</p>	
<pre> if (adaptation_field_extension_flag == '1') { } </pre>		not used
<pre> for (i=0; i&lt;N; i++) {   stuffing_byte } } </pre>	<p>8</p>	

### 5.3.4.2 PES packet specification

A PES packet shall have the structure shown in Table 6.

TABLE 6  
Structure of a PES packet

Syntax	Number of bits	Restrictions
<pre> PES_packet() {   packet_start_code_prefix   stream_id   PES_packet_length   if (stream_id !=program_stream_map   &amp;&amp; stream_id !=padding_stream   &amp;&amp; stream_id !=private_stream_2   &amp;&amp; stream_id !=ECM   &amp;&amp; stream_id !=EMM   &amp;&amp; stream_id !=program_stream_directory   &amp;&amp; stream_id !=DSMCC_stream   &amp;&amp; stream_id !=ITU-T Rec. H.222.1 type E stream) {     '10'     PES_scrambling_control     PES_priority     data_alignment_indicator     Copyright     original_or_copy     PTS_DTS_flags     ESCR_flag     ES_rate_flag     DSM_trick_mode_flag     additional_copy_info_flag     PES_CRC_flag     PES_extension_flag     PES_header_data_length     if (PTS_DTS_flags == '10') {       '0010'       PTS [32..30]<sup>(1)</sup>       Marker_bit       PTS [29..15]       Marker_bit       PTS [14..0]       Marker_bit     }   }   if ( PES_extension_flag == '1') {   }   for (i=0; i&lt;N1; i++) {     Stuffing_byte   }   for (i=0; i&lt;N2; i++) {     PES_packet_data_byte   } } </pre>	<pre> 24 8 16 2 2 1 1 1 1 2 1 1 1 1 1 1 1 8 4 3 1 15 1 15 1 8 8 8 </pre>	<pre> 0xFA '00' '10' or '00' '0' '0' '0' '0' '0' not used </pre>

<sup>(1)</sup> The PTS field is included in a PES header only when the encapsulated SL packet header contains an OCR. Otherwise, the PTS field is not used.

The following rules are applied at the transmitting side in order to allow random accesses at the receiving side:

- A PAT (Programme Association Table) shall describe only one programme, and its transmission period shall be no greater than 500 ms.
- A PMT (Programme Map Table) shall have the structure shown in Table 7 and adhere to the following rules:
  - A group of descriptors with Restriction “A” in the Table shall include an IOD\_descriptor.
  - A group of descriptors with Restriction “B” in the Table shall include an SL descriptor for an ES\_ID.
  - The transmission period of a PMT shall be no greater than 500 ms.
- The transmission period for scene description information and object description information shall be no greater than 500 ms.

TABLE 7  
Structure of a PMT

Syntax	Number of bits	Restrictions
TS_program_map_section() {		
<b>table_id</b>	8	
<b>Section_syntax_indicator</b>	1	
'0'	1	
<b>Reserved</b>	2	
<b>Section_length</b>	12	
<b>Program_number</b>	16	
<b>Reserved</b>	2	
<b>Version_number</b>	5	
<b>current_next_indicator</b>	1	
<b>Section_number</b>	8	
<b>Last_section_number</b>	8	
<b>Reserved</b>	3	
<b>PCR_PID</b>	13	
<b>Reserved</b>	4	
<b>Program_info_length</b>	12	
for (i=0; i<N; i++) {		
descriptor()		A
}		
for (i=0; i<N1; i++) {		
<b>stream_type</b>	8	'0x12' or '0x13'
<b>Reserved</b>	3	
<b>elementary_PID</b>	13	
<b>Reserved</b>	4	
<b>ES_info_length</b>	12	
for (i=0; i<N2; i++) {		
descriptor()		B
}		
}		
<b>CRC_32</b>	32	
}		

To ensure the audio-visual synchronization, the following rules shall be applied:

- The transmission period of a PCR within a transport stream shall be no greater than 100 ms.
- The transmission period of an OCR in the ISO/IEC 14496-1 SL layer shall be no greater than 700 ms.

The transmission period of a CTS in the ISO/IEC 14496-1 SL layer shall be no greater than 700 ms.

### 5.3.5 Error protection

#### 5.3.5.1 Outer coding

The shortened RS (204,188,  $t = 8$ ) derived from RS (255,239,  $t = 8$ ) is used for encoding.

The code and field generator polynomials of RS (255,239,  $t = 8$ ) are as follow:

- code generator polynomial:  $g(x) = (x+\lambda^0)(x+\lambda^1)(x+\lambda^2)\dots(x+\lambda^{15})$ ,  $\lambda = 02(\text{HEX})$
- field generator polynomial:  $p(x) = x^8 + x^4 + x^3 + x^2 + 1$

In order to obtain the shortened RS code, the first 51 input bytes for the RS (255,239,  $t = 8$ ) encoder are assumed to be zero. After encoding, the 51 zero bytes, which precede the valid 204-byte RS codeword at the output of the RS (255,239,  $t = 8$ ) encoder, are discarded.

The 16-byte parity of the shortened RS code shall be located at the end of an MPEG-2 TS packet as shown in Fig. 12.

FIGURE 12  
Structure of an MPEG-2 TS packet encoded by RS (204, 188,  $t = 8$ )

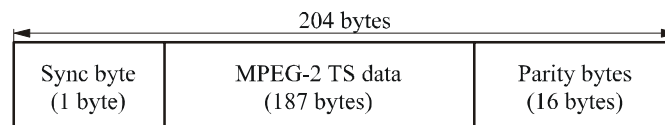

Rap 2049-12

#### 5.3.5.2 Outer interleaver

The convolutional byte-wise interleaver based on the Forney approach shall be used with the interleaving depth  $I = 12$  bytes as shown in Fig. 5.

Figure 6 shows the data structure after applying the outer interleaving process to the RS-encoded TS packets.

### 5.3.6 Content formats

The contents of the service are composed of video objects (ITU-T H.264 | MPEG-4 AVC), audio objects (MPEG-4 ER-BSAC), and auxiliary data objects (MPEG-4 BIFS). All the objects are packetized and synchronized using MPEG-4 SL. Compressed multimedia data are multiplexed by using MPEG-2 TS. To improve efficiency, some appropriate restrictions specified in this Annex apply to the multiplexing mechanism based on MPEG-2 TS.

For the instantiation of a video service, the additional error protection mechanism specified in § 5.3.5 shall be applied to the multiplexed data before delivery through the stream mode.

#### 5.3.6.1 Composition of MPEG-4 contents

Among several OD profiles defined in the ISO/IEC 14496-1 Standard, tools defined in the “Core Profile” are used for the composition of the contents in the T-DMB video services. However, the IPMP tool is not used.

There are restrictions imposed on the MPEG-4 descriptors that are used for the composition of contents in the T-DMB video services.

The following descriptors shall always be used:

- Object Descriptor
- Initial Object Descriptor
- ES Descriptor
- Decoder Config Descriptor
- SL Config Descriptor

The following descriptors are not used:

- IPI Descriptor Pointer
- IPMP Descriptor Pointer
- IPMP Descriptor

Object types that can be used to compose contents for video services are listed in Table 8.

TABLE 8  
Object types

ObjectTypeIndication	Object type
0×02	Systems ISO/IEC 14496-1
0×21	Visual ISO/IEC 14496-10
0×40	Audio ISO/IEC 14496-3
0×6C	Visual ISO/IEC 10918-1
0×C0-0×FE	User private

Stream types that can be used to compose contents for the T-DMB video services are listed in Table 9.

For the broadcasting where only a combination of a single video object and a single audio object is used, refer to Appendix 2 of this Annex for IOD/OD/BIFS.

TABLE 9  
Stream types

streamType value	Stream type
0×01	ObjectDescriptorStream
0×02	ClockReferenceStream
0×03	SceneDescriptionStream
0×04	VisualStream
0×05	AudioStream
0×20-0×3F	User private

For the content access procedure at the receiving terminals playing a video service, refer to Appendix 3 of this Annex. For video services, only one video object and one audio object shall be rendered simultaneously in a scene.

### 5.3.6.2 Packetization of MPEG-4 contents

- MPEG-4 contents shall be packetized as Sync Layer (SL) packets as defined in the ISO/IEC 14496-1 Standard. The following rules are applied to SL packet headers:
- The “useAccessUnitStartFlag” field has no restriction on its value.
- The “useAccessUnitEndFlag” field has no restriction on its value, but shall always be used with the “useAccessUnitStartFlag” field.
- The “useRandomAccessPointFlag” field should be set to “0”<sup>9</sup>.
- The “hasRandomAccessUnitsOnlyFlag” field should be set to “0”.
- The “usePaddingFlag” field should be set to “0”<sup>10</sup>.
- The “useTimeStampsFlag” field should be set to “1”.
- The “useIdleFlag” field should be set to “1”.
- The “durationFlag” field has no restriction on its value.
- The “timeScale” field shall always be used if the “durationFlag” field has the value of “1”.
- The “accessUnitDuration” field shall always be used if the “durationFlag” field has the value of “1”.
- The “compositionUnitDuration” field shall always be used if the “durationFlag” field has the value of “1”.
- The “timeStampResolution” field shall be set to 90 000 Hz.
- The “OCRResolution” field shall be set to 90 000 Hz.
- The “timeStampLength” field shall be less than or equal to 33 bits.
- The “OCRLength” field shall be less than or equal to 33 bits.
- The “AU\_Length” field should be set to “0”.
- The “instantBitrateLength” field has no restriction on its value<sup>11</sup>.
- The “degradationPriorityLength” field should be set to “0”.
- The “AU\_seqNumLength” field should be set to “0”.
- The “packetSeqNumLength” field should be set to “0”.

The recovery and usage of timing information shall refer to the following:

- Paragraphs 2.11.3.3, 2.11.3.4 and 2.11.3.6 in the ISO/IEC 13818-1 Standard: 2000(E).
- The OCR defined in the ISO/IEC 14496-1 Standard shall synchronize all the objects necessary for the description of a scene.

### 5.3.6.3 Audio object

Audio object specification conforms to the ER BSAC Audio Object Type with ObjectType ID 22 defined in the ISO/IEC IS 14496-3 Standard.

---

<sup>9</sup> Random access is supported by using the “random\_access\_indicator” field within the TS packet.

<sup>10</sup> Padding is employed in PES packets.

<sup>11</sup> This field shall be used if an OCR is encoded within an SL packet header since the “instantBitrate” field shall also be encoded in the case.

Audio object bit stream has the following restrictions:

- In `AudioSpecificConfig()`,
  - `epConfig`: set to 0
- In `GASpecificConfig()`,
  - `frameLengthFlag`: set to 0
  - `DependOnCoreCoder`: set to 0
- In `bsac_header()`,
  - `sba_mode`: set to 0 so that the error resilience tool is not supported
- In `general_header()`,
  - `ltp_data_present`: set to 0

The restrictions in Table 10 shall be applied.

TABLE 10  
Restrictions on audio objects

Item	Value
Sampling rate	24 000 Hz, 44 100 Hz, 48 000 Hz
Number of channels	1, 2
Number of objects	1
Maximum bit rate	128 kbit/s

#### 5.3.6.4 Video object

Video objects should be in compliance with ITU-T Recommendation H.264 | ISO/IEC 14496-10. Video bit streams shall comply with the items which will be described in the next subsections.

##### 5.3.6.4.1 Profile and levels supported

###### *Profile*

Video bit streams shall comply with the “Baseline Profile” (ITU-T Rec. H.264 | ISO/IEC 14496-10 Annex A.2.1).

- “Arbitrary slice order” shall not be allowed.
- The “`num_slice_groups_minus1`” field should be set to “0” in the syntax of “Picture Parameter Sets”.
- The “`redundant_pic_cnt_present_flag`” field should be set to “0” in the syntax of “Picture Parameter Sets”.
- The “`pic_order_cnt_type`” field should be set to “2” in the syntax of “Sequence Parameter Sets”.
- The “`num_ref_frames`” field should be set to “3” in the syntax of “Sequence Parameter Sets”.

###### *Level*

- Level 1, 3 of Table A-1 in Annex A to ITU-T H.264 | ISO/IEC 14496-10 AVC shall be used with the following further restrictions.
- The formats listed in Table 11 shall be supported.

- Vertical MV component range (MaxVmvR) shall be  $[-64, +63.75]$ .
- Maximum frame rate for the format shall be 30 fps.
- MaxDPB shall be 445.5 kbytes at maximum.

TABLE 11

**The formats supported**

Format	PicWidthInMbs	FrameHeightInMbs	PicSizeInMbs
QCIF	11	9	99
QVGA	20	15	300
WDF <sup>(1)</sup>	24	14	336
CIF	22	18	396

<sup>(1)</sup> Wide DMB format. This format was newly introduced to support 16:9 screen aspect ratio.

**5.3.6.4.2 Specification related to the transport of a video stream**

To enable random access at the receiving side, IDR pictures shall be encoded within a video stream at least once every 2 s.

The “Parameter Set” shall be delivered through Decoder Specific Info or included in the video stream itself.

The specification related to the transport of a video stream after MPEG-4 SL packetization shall comply with Clause 14 of the ISO/IEC 14496-1 Standard: 2001 Amendment 7.

**5.3.6.5 Auxiliary data specification**

This specification is used only when auxiliary information is transported or synchronized interactive services are provided.

**5.3.7 Scene description specification**

The scene description specification complies with Core2D@Level 1 defined in the ISO/IEC 14496-1 Standard.

**5.3.8 Graphics data specification**

The graphics data specification complies with Core2D@Level 1 defined in the ISO/IEC 14496-1 Standard.

Further information is provided in Appendix 2.

**5.4 Transmission mechanisms of FLO**

The FLO technology is designed to satisfy the increasing consumer demand for mobile multimedia content to mobile devices. These requirements include high content quality and diversity, low battery consumption, while always-on network capacity and cost effective infrastructure. The service layering shown in Fig. 13 enables the creation, transmission and reception of multimedia content in an efficient manner over a broadcast network to mobile terminal.

Figure 13 depicts the layering of the delivery service on the FLO mobile broadcast network.



FIGURE 13

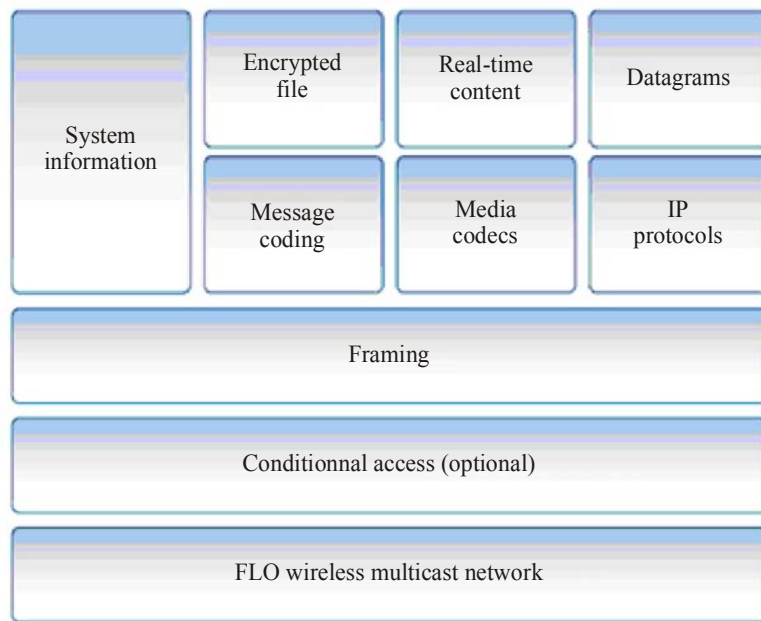

Report 2049-13

As shown in Fig. 13, the “System and control information” layer uses common communications protocols, which provide the receiving terminal with the information required to acquire, navigate and consume the services offered.

The transport mechanisms are based on open packet-data protocols, which efficiently support broadcast transmission of video or audio streams as well as IP data.

The FLO system supports QVGA display resolution for mobile multimedia applications on handheld receivers or other mobile or vehicular devices. QVGA resolution is appropriate for mobile handheld display sizes given the characteristics of the human visual system. The FLO system uses efficient compression technologies, such as ITU-T Recommendation H.264 for video and MPEG-4 AACplus v2 for audio, to support high quality multimedia services using a statistical multiplexed VBR service with an average bit rate between 200-250 kbit/s at QVGA resolution.

The system supports transmission with different levels of robustness in association with appropriate applications. The transmission coding can be optimized relative to a required quality of service.

Further information is provided in Appendix 4.

## 6 Display patterns on mobile receivers

It is helpful to consider how to use display to understand the specifications of multimedia and data applications. Figures 14 and 15 provide examples of display patterns for basic handheld receivers and enhanced handheld and vehicular receivers, respectively.

A basic handheld receiver has a simplified displaying capability. It is likely that such display patterns will not make use of overlapping of more than two planes. Figure 14 shows possible display patterns, which are implemented for basic handheld receivers depending on the considered resolution.

However, enhanced handheld and vehicular receivers may have a layout that is similar to a fixed receiver although it is likely to have a different display resolution as illustrated in Fig. 15. These receivers have resolution displays of  $352 \times 288$  or lower, while a fixed receiver can have an HDTV display, i.e.  $1\,920 \times 1\,080$  resolution.

FIGURE 14

Examples of display patterns of image and data on basic handheld receivers

Minimal display (portrait)

Image 16:9 1/2: 160 × 90 3/4: 240 × 135 1/1: 320 × 180	Image 4:3 1/2: 160 × 120 3/4: 240 × 180 1/1: 320 × 240	Display area for data	Applicable display size: 160 × 160 240 × 240 360 × 360
Display area for data	For data		

Desirable display (portrait)

Image 16:9 1/2: 160 × 90 3/4: 240 × 135 1/1: 320 × 180	Image 4:3 1/2: 160 × 120 3/4: 240 × 180 1/1: 320 × 240	Display area for data	160 × 200 240 × 300 360 × 400
Display area for data	Display area for data		

Image 16:9 2/3: 213 × 120 1/1: 320 × 180 2/1: 620 × 360	Image 4:3 2/3: 213 × 160 1/1: 320 × 240 2/1: 620 × 480	Display area for data	213 × 160 320 × 240 640 × 480
Display area for data	(No data part)		

	For data		For data	320 × 240 640 × 480
Image 16:9 1/2: 160 × 90 1/1: 320 × 180		Image 4:3 1/2: 160 × 120 1/1: 320 × 240		

Desirable display (landscape)

Image 16:9 1/1: 320 × 180 2/1: 620 × 360	Image 4:3 3/4: 240 × 180 3/2: 480 × 360	Display area for data	400 × 240 (427 × 240) 800 × 480 (835 × 480)
Display area for data	Display area for data		

Image 16:9 5/8: 200 × 112 5/4: 200 × 224	Display area for data	Image 4:3 5/8: 200 × 150 5/4: 400 × 300	Display area for data	400 × 240 (427 × 240) 800 × 480 (835 × 480)

FIGURE 15

## Layout patterns of image and data on handheld and vehicular receivers

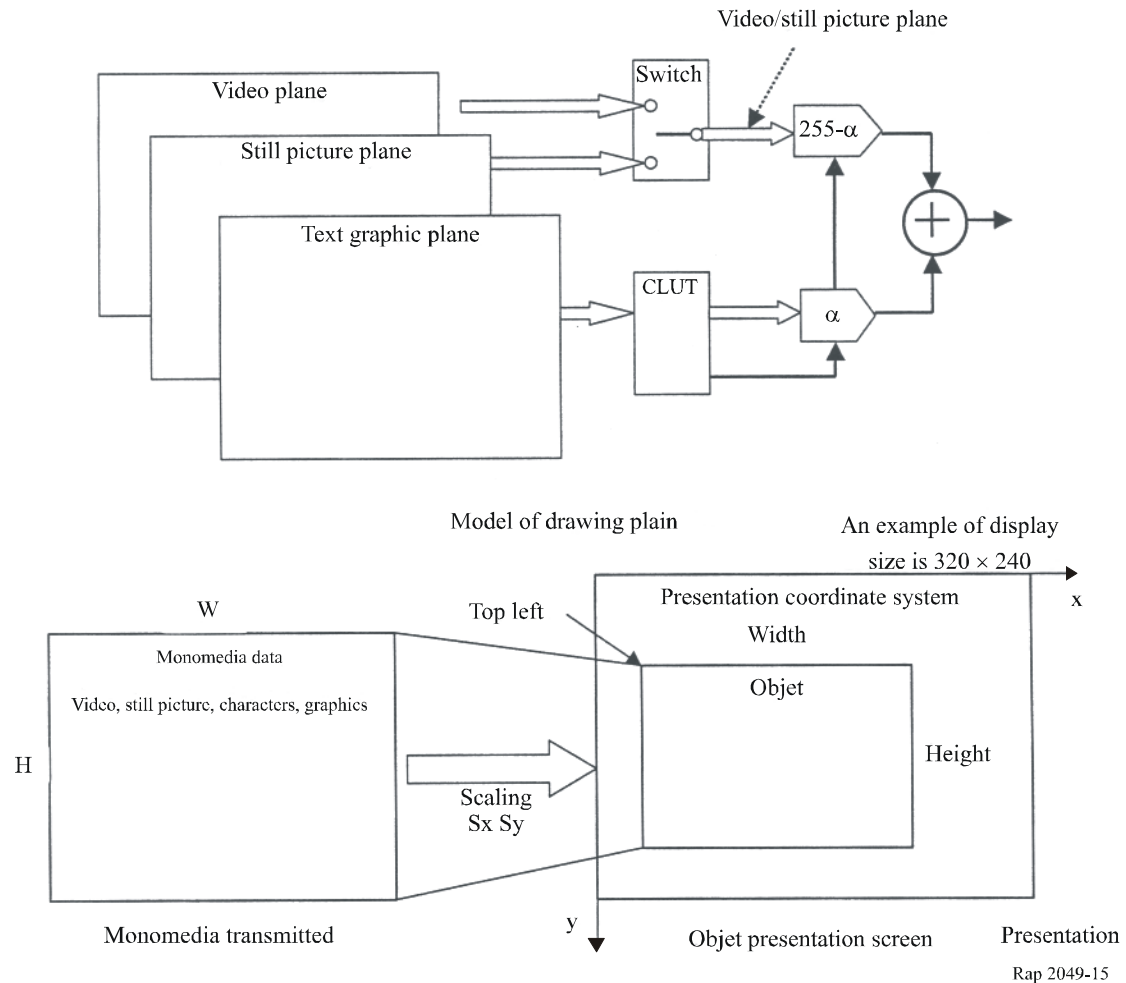

## 7 Conclusion

This Report reflects different technologies and multiple implementation approaches.

## Appendix 1

### Launching of digital terrestrial sound broadcasting services in Japan

The following parts provide the current status of preparations for Japanese terrestrial sound broadcasting services.

The first one is a schedule of broadcasting services. The timetable for launching terrestrial sound broadcasting services in the future is shown in the following:

- April 2003: Starting test transmission using pre-commercial broadcasting facilities.
- October 2003: Starting pre-commercial broadcasting services in both Tokyo and Osaka areas using VHF Channel 7 (4 MHz bandwidth around 220 MHz).

After 2011: Grand opening of terrestrial digital sound broadcasting services all over Japan.

Interoperability between three types for terrestrial broadcasting systems is shown in Fig. 16. Basic portable receivers could receive three types of digital broadcasting services. The first one is one-segment digital terrestrial sound broadcasting services that use one frequency segment. The second one is the case using the centre segment of three-segment digital sound broadcasting systems. The third one is the case using the centre segment of digital terrestrial television broadcasting services that make use of thirteen segments in total.

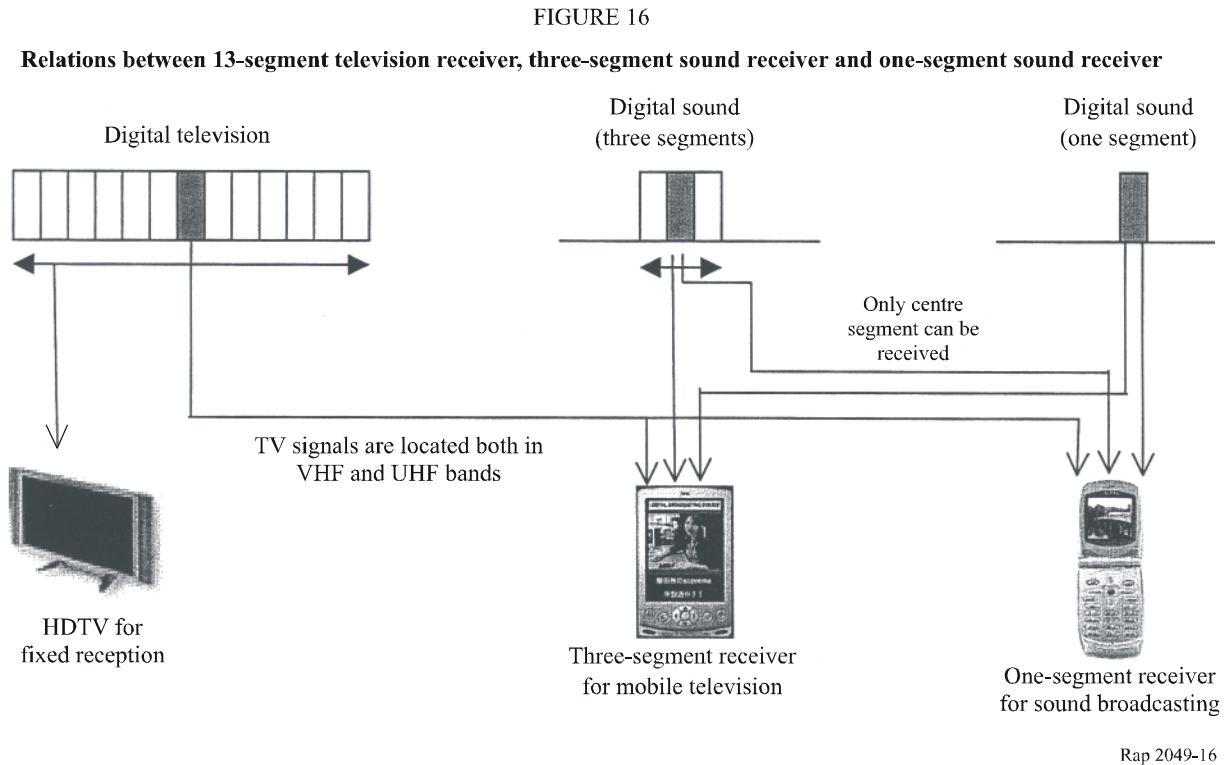

Enhanced receivers can receive three-segment sound broadcasting services with their three-segment receiving capability. In this case, rich contents are available for portable and mobile receivers by using enhanced receivers.

### Broadcasting services planned by Tokyo FM station

The following are the current planning of digital terrestrial sound broadcasting services created by the Tokyo FM Radio Station. Figure 17 shows a typical application for three-segment receiver.

A streaming sound programme with various kinds of associated data is the typical case of this FM radio station. In order to satisfy bandwidth requirements for such rich multimedia and data broadcasting services, three frequency segments are required. It is noted that one segment has 432 kHz frequency bandwidth.

FIGURE 17  
A typical application for enhanced receivers



Rap 2049-17

**One segment receiver and three-segment receiver**

Figure 18 shows the difference of displayed visual contents between one-segment receiver and three-segment receiver.

FIGURE 18  
Relations between three-segment sound receivers and one-segment sound receiver

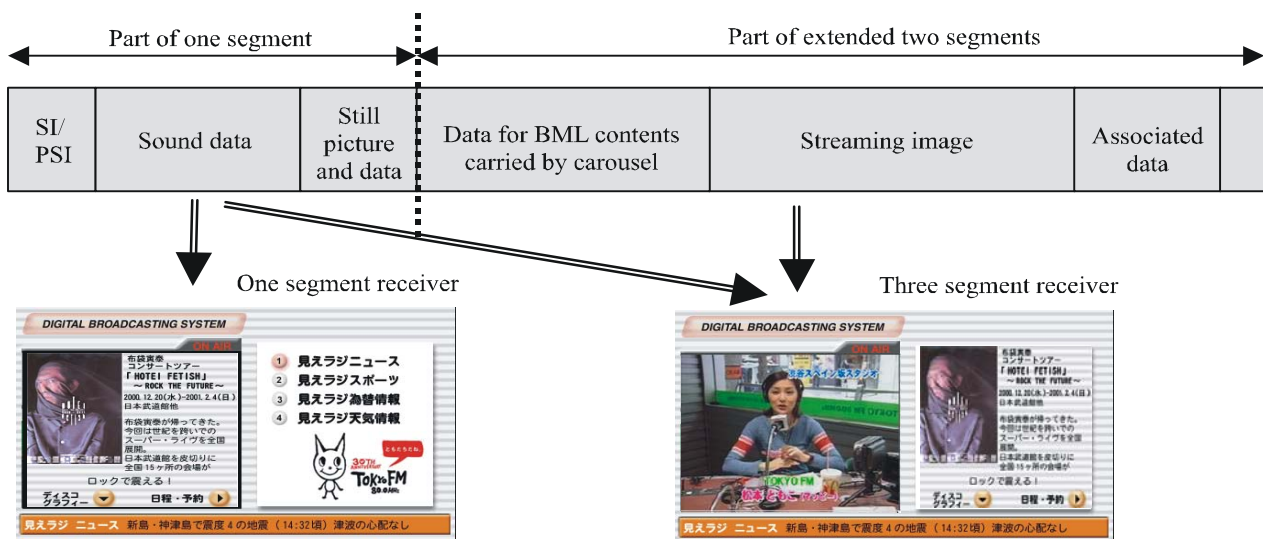

Sound plus still picture/data

Streaming image and sound plus BML contents

Rap 2049-18

**Interactive broadcasting service for portable receiver**

Interactive applications are also important for portable receivers. Figure 19 shows one example of ticket reservation by using interactive capability provided by ARIB STD-B24.

FIGURE 19

An example of interactive broadcasting application for ticket reservations

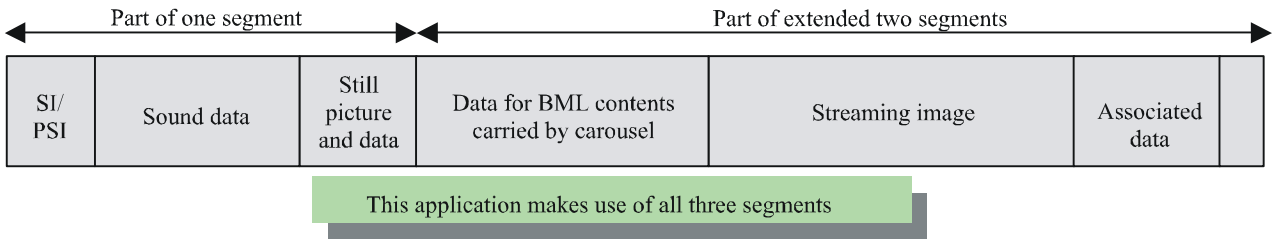

1) Event menu



2) Select one of the movies (Cabaret)



3) Timetables of the movies (Cabaret)



4) Reserve the ticket for Cabaret



Rap 2049-19

Data broadcasting for client storage

Recently, new ARIB STD-B38 for broadcasting to client storages was approved formally. Figure 20 provides the conceptual diagram of this type of broadcasting services.

FIGURE 20

## An example of broadcasting applications for client storage

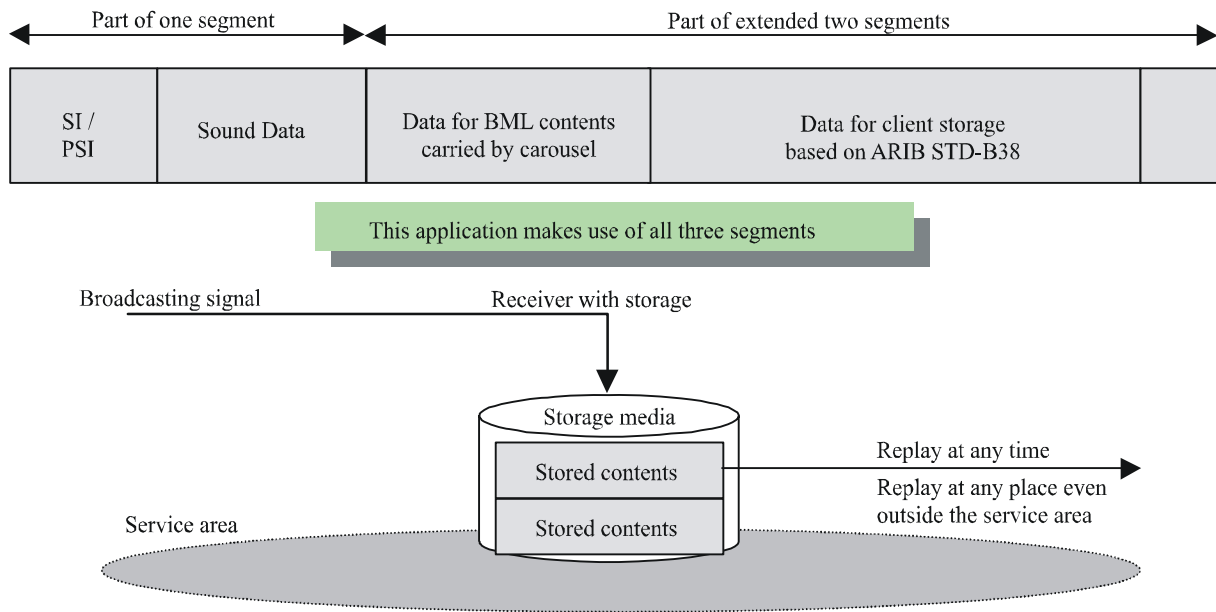

Rap 2049-20

## Several types of portable receivers and mobile receivers

Typical types of receivers with brief explanations are shown in Fig. 21.

FIGURE 21

## Several types of receivers



Rap 2049-21

The following are brief explanations for these four types of receivers.

- Simple pocket radio: sound reception only.
- Pocket radio/car radio with simplified display capability of a few lines of characters.
- Portable phone type receiver.
- Personal digital assistant (PDA) type receiver.

Three other types of receiver are considered without figures in this Report.

- e) 5.1-channel surround stereo receiver for car audio system.
- f) Fixed digital sound receiver for high-fidelity stereo sound system.
- g) PCMCIA card type receiver for open-box type devices like PDA and note PC.

## Appendix 2

### Current Status of T-DMB Services and Advanced T-DMB

#### 1 System overview

T-DMB has been designed exclusively to provide services on mobile and portable platforms. T-DMB is designed to provide video services for users in mobile environment guaranteeing the backward compatibility with DSB System A. MPEG-4 AVC codec for video and MPEG-4 BSAC/MPEG-4 HE-AAC codec for audio are used for video services. The Binary Format for Scenes (BIFS) in conjunction with MPEG-4 Synchronization Layer (SL) provides frame based local interactive data service associated with video service. For audio services, DSB System A in Recommendation ITU-R BS.1114 uses MUSICAM.

Data services such as Electronic Programme Guide (EPG), traffic information, web page services are provided using Transparent Data Channel (TDC), Multimedia Object Transfer (MOT), Broadcast WebSite (BWS), IP-tunneling, slideshow, etc.

FIGURE 22

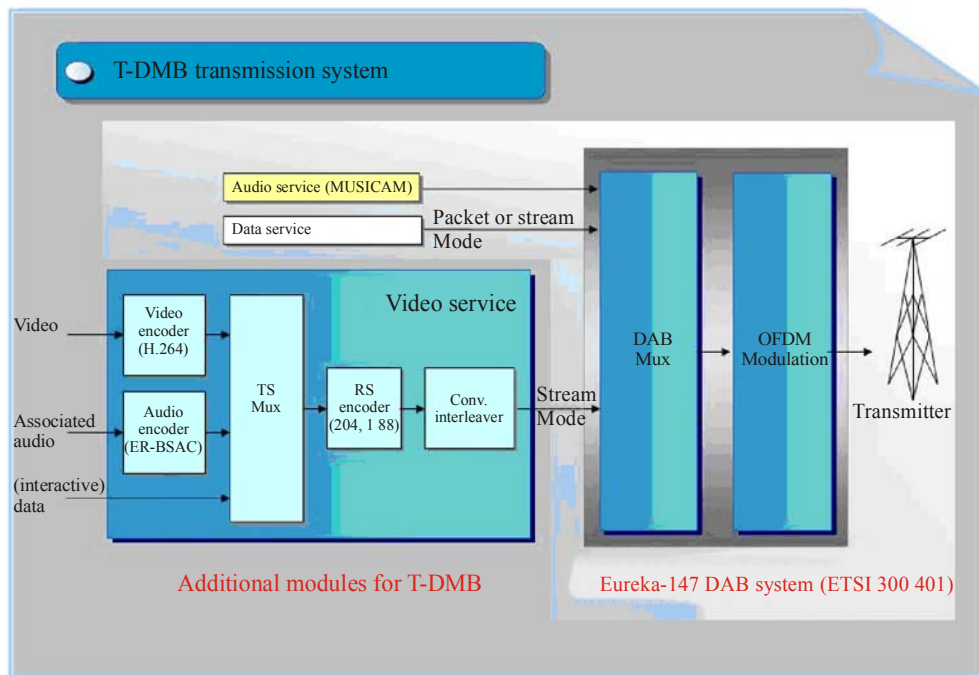

Report 2049-22

Figure 22 shows the T-DMB transmission system. As it can be seen, the T-DMB modules have been added in front of the original DAB system, without any modifications or changes to the existing DAB transmission infrastructure. Video and audio encoders encode the multimedia



contents. Block coding (Reed Solomon encoder, convolutional interleaver) has been included for reliable and stable reception of video services in a high-speed mobile environment.

**2 Market status of T-DMB receivers in Korea**

Since the commercial launch of T-DMB in December 2005, more than 16.9 million T-DMB receive units have been sold in Korea as of December 2008 as shown in Fig. 24.

A variety of T-DMB receivers are currently available in the market. The popular type of T-DMB receiver can be found in mobile phone followed by GPS car navigation as shown in Fig. 25.

FIGURE 23

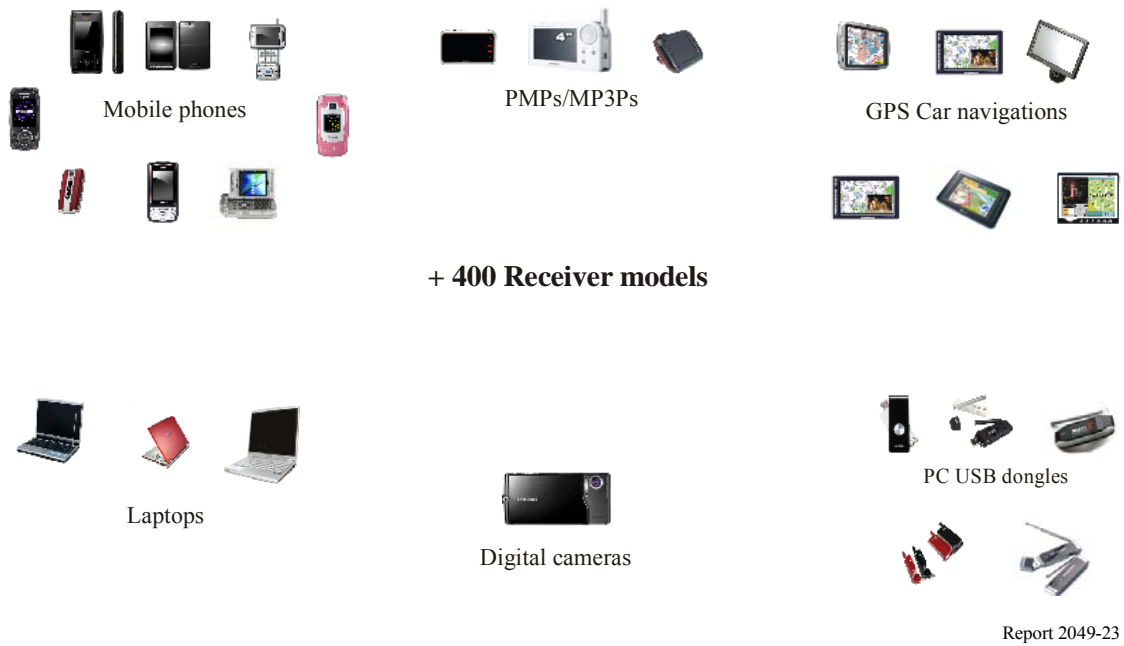

FIGURE 24

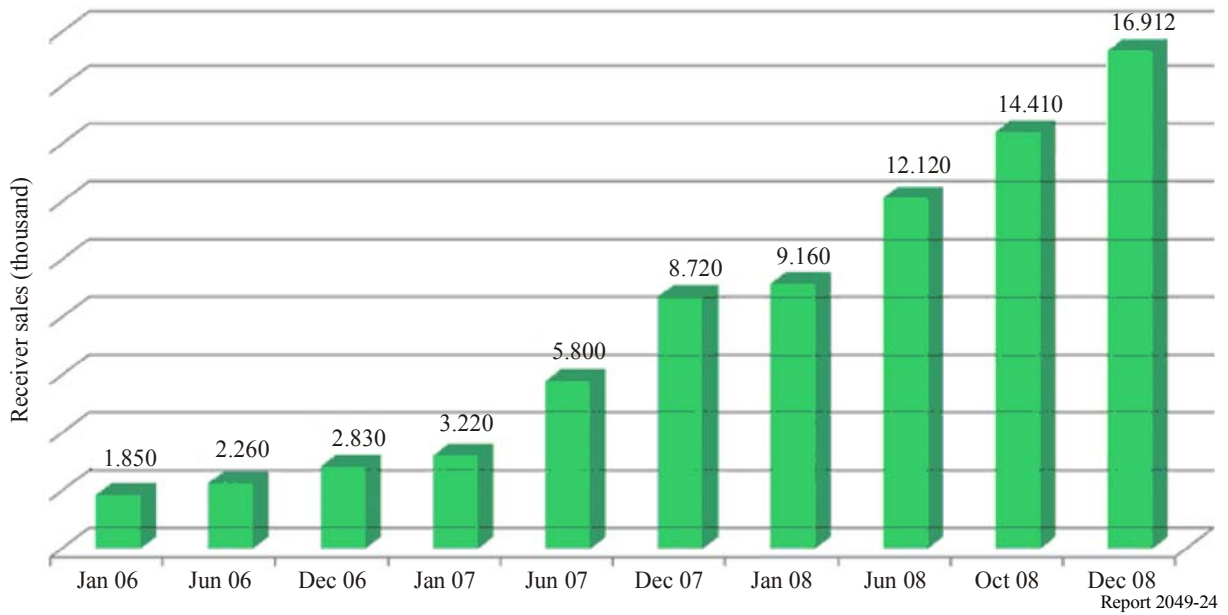
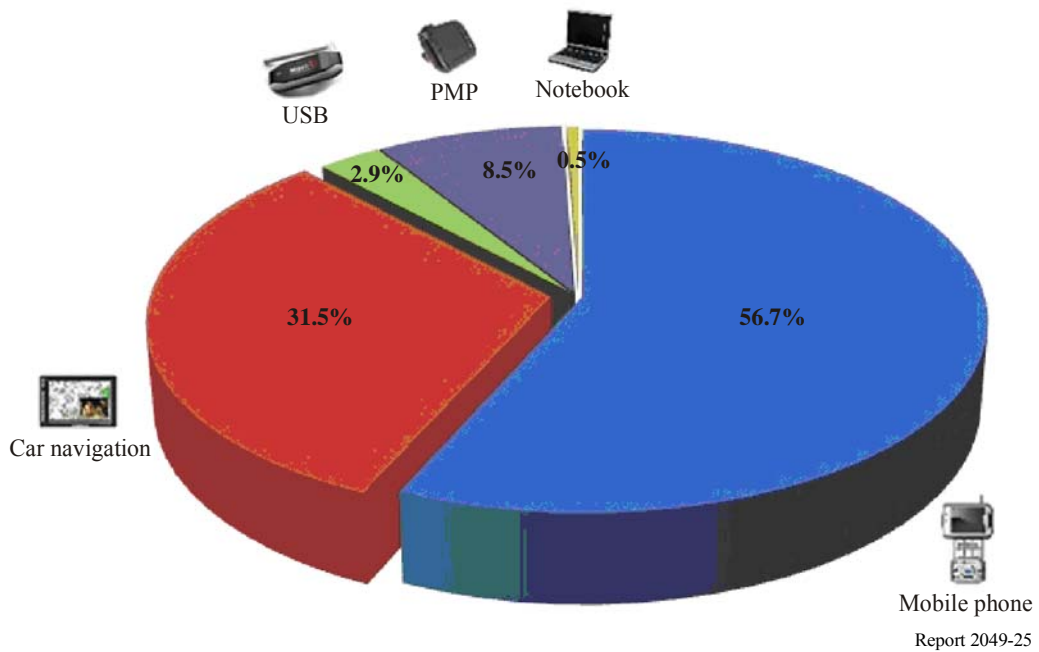

FIGURE 25



### 3 Applications of T-DMB

#### 3.1 Transport protocol expert group (TPEG)

Real-time traffic and travel information is provided by using the TPEG standard on DMB networks. Diverse traffic related information is provided, such as real-time traffic congestion, road conditions, bus routes, traffic news, etc. TPEG service, in conjunction with GPS map navigation, enables finding faster routes and provides information on road condition changes in real-time.

In addition, TPEG service provides activity and event information on the road and location information based on location referencing method. The user can search tourist attractions as well as popular dining places in a specific location. Other related services such as making reservations are expected to be available soon.

Currently, four T-DMB service providers are offering TPEG services in Korea. TPEG related revenue is estimated to be equivalent to advertisement related revenue, and it is gradually increasing.

The different TPEG services which are currently being offered in Korea are described in more detail below.

#### Road traffic message (RTM)

Shows accidents, construction notices, and other activities on the road. This information is included in the time calculating method of CTT (explained below).

FIGURE 26



Report 2049-26

#### Point of interest (POI)

Gives information on various service facilities within the selected area. Commercial information such as descriptions on restaurants, theatres, shopping centres, gas stations and more are provided to the viewers through the T-DMB network. People can plan their travel schedules with attractive destinations and preferred choice of cuisines.

FIGURE 27



Report 2049-27

**Congestion and travel-time information (CTT)**

Calculates the travel time by considering the traffic status and predicted speed to the destinations. Information is shown on the display with different colours indicating the congestion level.

FIGURE 28



Report 2049-28

**CTT summary information (CTT-SUM)**

Displays the summary of total road traffic status in the selected area. It will enable the drivers to decide which route to get to the desired destinations.

FIGURE 29



Report 2049-29

### 3.2 Broadcast website (BWS)

T-DMB devices can receive real-time broadcasting news in the form of Internet web pages. Various contents such as news, stock market info, programme info, traffic, weather, sports, etc., are transferred through DMB network by using the MOT protocol, giving the users a feeling as if they are surfing the web. Information is updated on a 15 to 30 min basis and the device should support HTML4.0 compatible web browsers. However, since it utilizes a broadcasting network, interactive services cannot be supported as of yet.

FIGURE 30

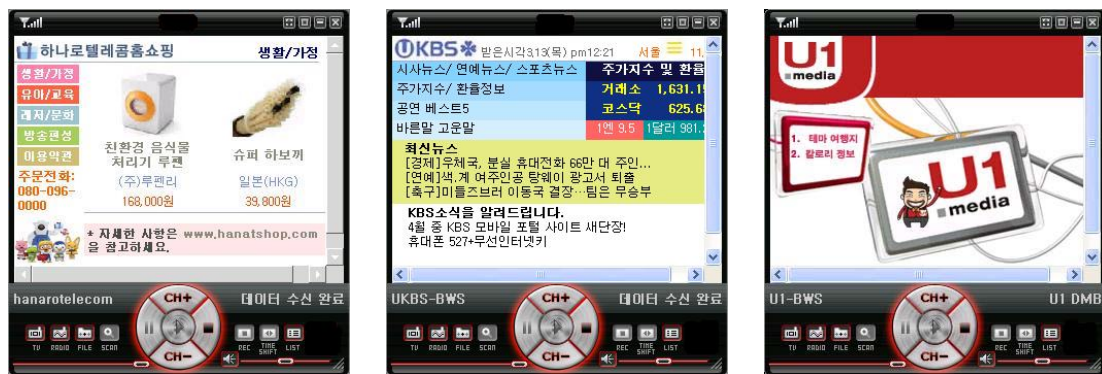

Report 2049-30

### 3.3 Binary format for scenes (BIFS)

BIFS is an MPEG-4 scene description protocol that allows bidirectional services by interconnecting different programmes. The user can buy clothes or accessories for a game character, search restaurants and look for directions, and submit user opinions. BIFS interworks video and data services, utilizes DMB's video service standard based on MPEG-4, and provides a service that is interlinked with video and audio for video. As of now, this service is connected with information related to TV programmes, entertainers, housing, and with links to shopping malls and programme PR sites. Non-interworked services provide information such as news, game, weather and the stock market.

FIGURE 31



### 3.4 Dynamic label service (DLS)

DLS is a textual service using X-PAD audio frame and provides information related to the audio broadcasting (programme info, singer info, song titles, etc.) as well as non-programme related information (news, weather, traffic information, etc.). DLS is used for providing simple and useful information to the user in a textual format.

FIGURE 32



### 3.5 Slideshow (SLS)

SLS is similar to DLS. SLS provides a service based on JPEG images, whereas DLS offers a textual service. Similarly to DLS, SLS uses mostly X-PAD audio frame and is able to provide interworked services (still-cut programme information, album jacket, singer's photo album, etc.) and non-interworked information (real-time traffic information provided by CCTVs and summarized maps, commercials, etc.). Basically, SLS and DLS are provided simultaneously on the same audio channel.

FIGURE 33



Report 2049-33

### 3.6 Emergency warning system (EWS)

This service deals with information on natural disaster such as tsunami, earthquake, flood and so on. The information will be sent to the public through the T-DMB network in text type. Since T-DMB has a wide coverage compared to other media, it will be effective in spreading out the urgent messages to prevent any possible loss of life and property in advance. It can also be used to alert unexpected accidents such as fire breakout, terrorist attack, and any other man-caused accidents.

The EWS standard is specified in Recommendation ITU-R BT./BO.1774: definition of emergency message, i.e. AEAS (Automatic Emergency Alert Service) message; the signalling and delivery method of the AEAS message using T-DMB; and functional requirements of T-DMB AEAS transmitting system and the AEAS receiver. The AEAS message format is designed to be short with essential information for swift delivery. In a serious situation, detailed information such as event descriptions and instructions in text or in other multimedia format will be followed in other services. The AEAS message format provides fields for the short text message and/or the external links. The AEAS provides targeted service according to the location of the receiver.

This service can contribute to the public good, and this is truly the most important function for broadcasters.

### 3.7 Electronic programme guide (EPG)

EPG is one of the essential elements for broadcasters to provide accurate and useful information to the viewers/audiences.

Viewers/Audiences have experienced a huge variety of channels since the digital broadcasting services started. However, the additional steps necessary to choose the desired channels create confusion among the users.

According to the ETSI standard, EPG is supposed to provide 2 types of programme guide services. One is Basic Profile which is mainly focused on listing names of programmes, and the other is Advanced Profile which shows both lists and summaries of selected programmes for bigger screens.

Currently, the “Advanced EPG solution” is being developed. It will enable the broadcasters to adapt more commercialized services, so called “customized profiles”. On the “customized profiles”, not

only programme guides but also advertisements and coupons can be displayed. This business model has been tried by a satellite mobile TV company in Korea, and the clients see it as a future commercial tool which can generate additional revenue.

- Programme guide information.
- Information sorting by channel, theme, and time.
- Programme recording.

### 3.8 Conditional access system (CAS)

CAS enables effective security measures and access control which allows only authorized users to gain access to the services and contents. Therefore, this allows mobile TV operators to have various business models for revenue generation. T-DMB services are currently free-to-air in Korea and do not incorporate CAS. In other parts of the world where T-DMB is a pay service, CAS is being used with T-DMB. Korea is also expected to launch T-DMB with CAS in the near future.

FIGURE 34

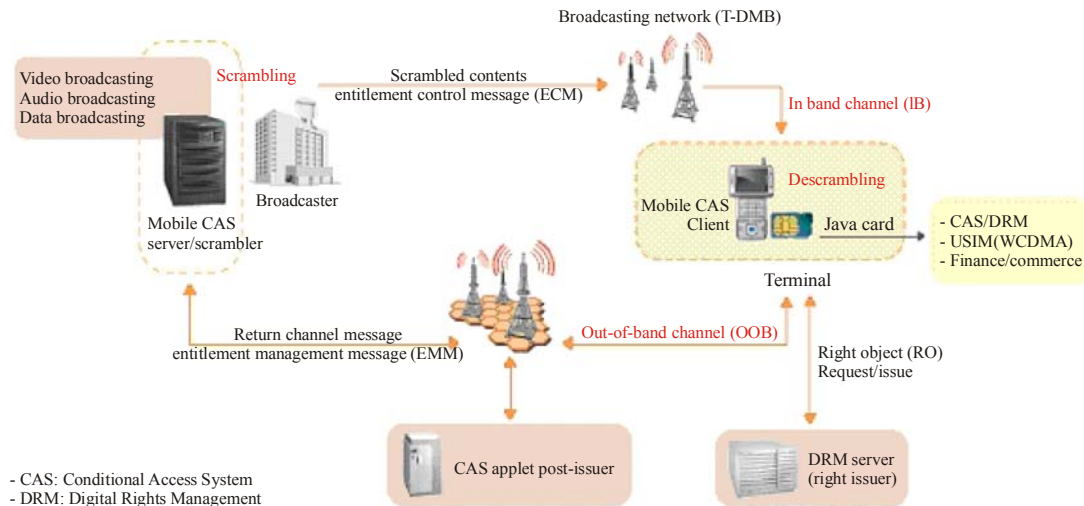

Report 2049-34

## 4 Advanced T-DMB

Along with the successful commercialization of the T-DMB services in Korea, much effort had been made to enhance the T-DMB technology, which was designed to deliver VCD quality video on top of CD-like quality audio and data services in a mobile environment. In order to meet the rapidly increasing demands of application services from the market, it had been a main concern to enhance the T-DMB system. Hence the advanced T-DMB technology development project was initiated for meeting these requirements of T-DMB users. The project, first of all, focuses on increasing channel capacity of the T-DMB and guarantees backward compatibility with the T-DMB system. The tentative name “advanced T-DMB” might be changed later.

### 4.1 Hierarchical modulation

To guarantee backward compatibility with the T-DMB, hierarchical modulation mechanism is applied. Hierarchical modulation is the technology modulating multiple data streams into one single symbol stream. The system architecture of the advanced T-DMB is shown in Fig. 35. The base



layer stream of the advanced T-DMB ensemble multiplexer is the same as that of the T-DMB ensemble multiplexer. Three different kinds of information (video, audio, data) are simultaneously applied for multiplexing also at the enhancement layer of the advanced T-DMB. Two distinct streams from both base layer and enhancement layer are transmitted through the advanced T-DMB ensemble multiplexer and the advanced T-DMB exciter. They constitute single stream before the layered modulation begins.

The advanced T-DMB Exciter receives two layer streams and modulates hierarchically and sends the modulated signal.

The advanced T-DMB defines two hierarchical modulation schemes, i.e. B mode using BPSK symbol mapping over DQPSK symbol and Q mode using QPSK symbol mapping over DQPSK symbol. B mode hierarchical modulation has better performance in a mobile environment, but it only increases effective data rate up to 1 and 1/2 times that of the T-DMB. On the other hand, Q mode hierarchical modulation increases effective data rate up to maximum twice as much as that of the T-DMB, but it does not guarantee high performance in a mobile environment. Therefore, Q mode hierarchical modulation is more advantageous in a fixed reception environment.

With these pros and cons, the advanced T-DMB gives more flexibility of selecting one of two hierarchical modulations to broadcasting stations.

FIGURE 35

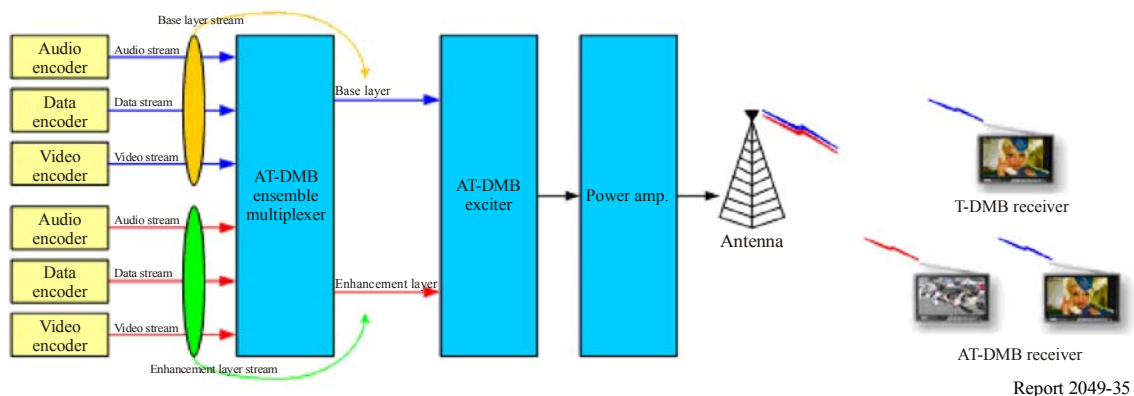

## 4.2 B mode hierarchical modulation

The constellation of T-DMB using DQPSK modulation is shown in Fig. 36. The constellation of BPSK symbol used for advanced T-DMB is shown in Fig. 37. The constellation after BPSK symbol is mapped over DQPSK symbol is shown in Fig. 38. The advanced T-DMB exciter uses DQPSK modulation for base layer stream, while BPSK modulation is used for enhancement layer. Figure 38 shows the output constellation of the advanced T-DMB exciter.

FIGURE 36

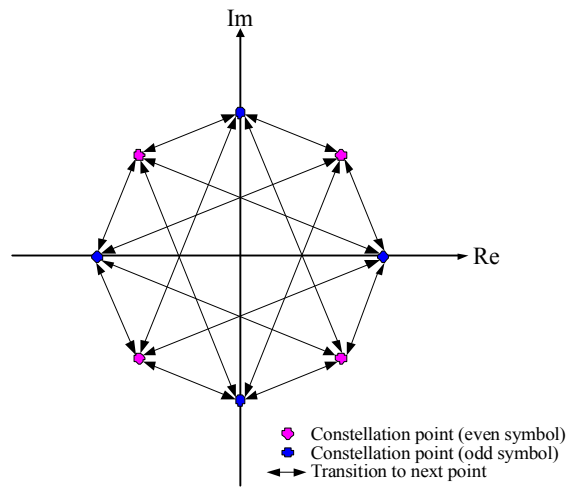

Report 2049-36

FIGURE 37

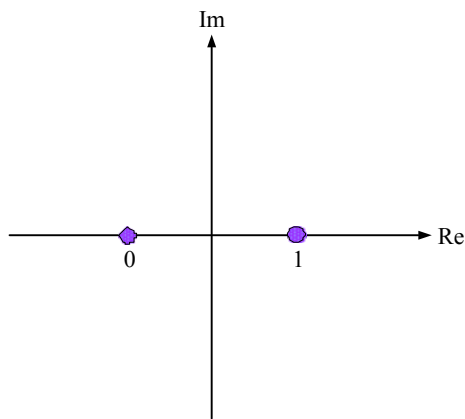

Report 2049-37

FIGURE 38

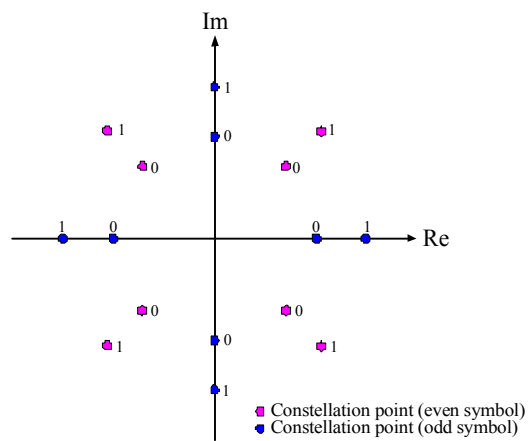

Report 2049-38

### 4.3 Q mode hierarchical modulation

The constellation of QPSK symbol is shown in Fig. 39. The constellation after QPSK symbol is mapped over DQPSK symbol is shown in Fig. 40. The advanced T-DMB exciter uses DQPSK modulation for base layer stream and QPSK modulation for enhancement layer. Figure 40 shows the output constellation of the advanced T-DMB exciter.

FIGURE 39

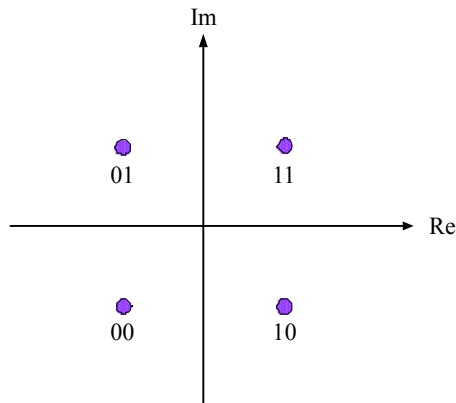

Report 2049-39

FIGURE 40

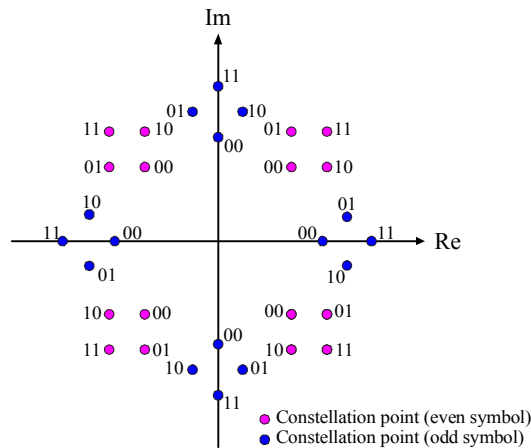

Report 2049-40

### 4.4 Constellation ratio

The constellation ratio in the Q mode hierarchical modulation is defined as:

$$\alpha = \frac{a}{b}$$

where:

- a*: minimum distance between two neighbouring quadrants
- b*: minimum distance between constellation points in a quadrant.

The constellation ratio of B mode and Q mode hierarchical modulation is shown in Fig. 41. The advanced T-DMB supports 4 constellation ratios specified as 1.5, 2.0, 2.5, and 3.0. By changing the value of the constellation ratio, the advanced T-DMB can adjust reception performance of advanced T-DMB receivers.

FIGURE 41

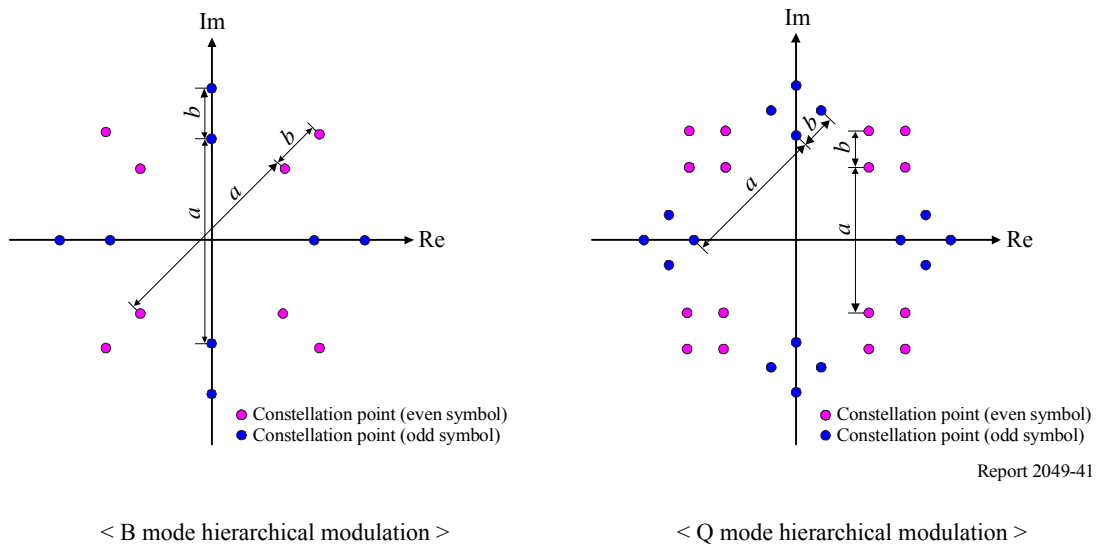

Report 2049-41

#### 4.5 Turbo code

The advanced T-DMB system introduces other channel code in the enhancement layer. To provide better performance, the enhancement layer of the advanced T-DMB system chooses turbo code instead of convolutional code used as in the T-DMB system. Linear Differential Predictive Coding (LDPC) is also a powerful channel code, but it is not suitable for small data burst.

Turbo code rates defined in the advanced T-DMB system are  $1/2$ ,  $2/5$ ,  $1/3$ ,  $1/4$ . Broadcasting stations can select one of the values according to their applications.

Table 12 shows major functionalities comparison of T-DMB and advanced T-DMB.

TABLE 12

Parameters of T-DMB and advanced T-DMB

Categories		T-DMB/ Advanced T-DMB base layer	Advanced T-DMB enhancement layer	
			BPSK	QPSK
Transmission	Bandwidth	1.712 MHz		
	Effective data rate	0.576~1.728 Mbit/s	0.288~0.576 Mbit/s	0.576~1.152 Mbit/s
	FEC	Convolutional code	Turbo code	
	Code rate	$1/4$ , $3/8$ , $1/2$ , $3/4$	$1/2$ , $2/5$ , $1/3$ , $1/4$	
	Modulation	DQPSK	BPSK over DQPSK	QPSK over DQPSK

TABLE 12 (*end*)

Categories		T-DMB/ Advanced T-DMB base layer	Advanced T-DMB enhancement layer	
			BPSK	QPSK
Video	Video compression	H.264		
	Audio compression	AAC+, BSAC		
	Transport stream	MPEG-2 TS system		
	FEC	Reed-Solomon (204, 188)		
Audio		MUSICAM (MPEG-1, 2 Layer 2)		
Data		MPEG-4 BIFS, BWS, slideshow, etc.		

## 5 Conclusions

This Report provides information on the background and present status of T-DMB in Korea.

T-DMB offers multimedia services, such as mobile TV, accessible virtually anywhere and at any time.

The unprecedented level of convenience offered by T-DMB is surely to make it a leading service in the telecom-broadcasting convergence market. As a major milestone in the history of digital mobile broadcasting, T-DMB will spawn new business models and provide new opportunities in the IT field.

This Report also introduces salient features of the advanced T-DMB system that would enhance and outperform the existing commercialized T-DMB system. The advanced T-DMB system also provides backward compatibility so that the existing T-DMB end users can receive conventional service with no additional cost. It supports the various code rates so the service providers can utilize the new system for diverse applications.

## Appendix 3

### The DVB-H Standard EN 302 304: Technology highlights commercial deployments

#### 1 The DVB-H standard for delivery and reception of content to handheld/mobile terminals

In November 2004, the European Telecommunications Standards Institute (ETSI) published DVB-H standard EN 302 304 for the distribution of multimedia content to handheld devices. Telecommunications Industry Association (TIA) adopted DVB-H as an official standard for Mobile Digital TV in the US in October 2006 (TIA-1105). In March 2008, the European Commission added DVB-H in the European Union List of Standards.

The DVB-H standard has been elaborated to be able to share broadcast multiplexes (MUX) with the DVB-T standard<sup>12</sup> wherever this may be an advantage for the actual service deployment.

The DVB-H standard is furthermore addressing two major technological challenges which exist for battery operated handheld terminals in the mobile domain, being power consumption and transmission robustness in the mobile environment, where Doppler distortion and multipath reflections hamper an error-free data reception if special measures are not taken.

## 2 Overview of the DVB-H delivery mechanism

The DVB-H standard specifies a transmission system using the key methodologies of the DVB-T standard to provide an efficient way of carrying multimedia services (including TV and sound) over digital terrestrial distribution networks serving handheld terminals.

Although the DVB-T transmission standard has proven its ability to serve fixed and transportable terminals, it has to be understood that mobile devices (defined as a small size, light-weight battery powered apparatus) do require additional features from the transmission system serving such terminals.

As the DVB-H system is specifically designed to serve mobile devices, the conservation of power by an operating receiver circuit has been optimized. This is achieved by the application of the so-called time-slicing methodology, based on a regularly submitted invitation by the fixed distribution network to power down parts of the handheld terminals reception chain. DVB-T receivers will simply neglect such invitation and thus in this regard stay backward compatible with the DVB-H signalling.

The DVB-H transmission system is furthermore aimed at serving both nomadic and mobile users, which require the capability in a seamless manner to support handovers and roaming between transmission cells in an indoor reception scenario as well as to offer a robust and reliable reception at high speeds in an in-vehicle usage scenario.

As finally the deployment of DVB-H based delivery networks are foreseen to take place in all regions of the world, the DVB-H standard has been designed to operate in all MUX-bandwidths being 5 MHz, 6 MHz, 7 MHz and 8 MHz as found in the global broadcasting Bands III, IV and V.

### 2.1 The DVB-H PHY and link layer

The physical layer of DVB-H is identical to the DVB-T (see EN 300 744) with the following elements specifically aimed at DVB-H signalling:

*Element 1:* The TPS bit section (transmission parameter signalling) is set to obtain fast service discovery as well as contain current cell identifier to speed up cell handover and frequency selection for roaming receivers.

*Element 2:* The 4K transmission mode as a good compromise to trade off mobility with cell sizes of a single frequency network (SFN) and the application of a single antenna at high speeds.

*Element 3:* Inclusion of an in-depth symbol interleaver to further improve reception robustness.

The link layer of DVB-H incorporates the time-slicing methodology to enhance the reduce power consumption and allow time for a smooth cell handover plus a mechanism of forward-error

---

<sup>12</sup> ETSI EN 300 744: "Digital Video Broadcasting (DVB); Framing structure, channel coding and modulation for digital terrestrial television" (DVB-T).

correction of multi protocol encapsulated data (MPE-FEC) to enhance Doppler and  $C/N$  performance as well as reception robustness in an impulse noise environment.

In order to offer DVB-H services, a distribution network must provide time-slicing, cell identifier and DVB-H signalling. The DVB-H is simply transporting IP datagrams in the MPE section, fully transparent to the DVB-T physical layer. The principle of the DVH-H demodulator is shown in Fig. 42.

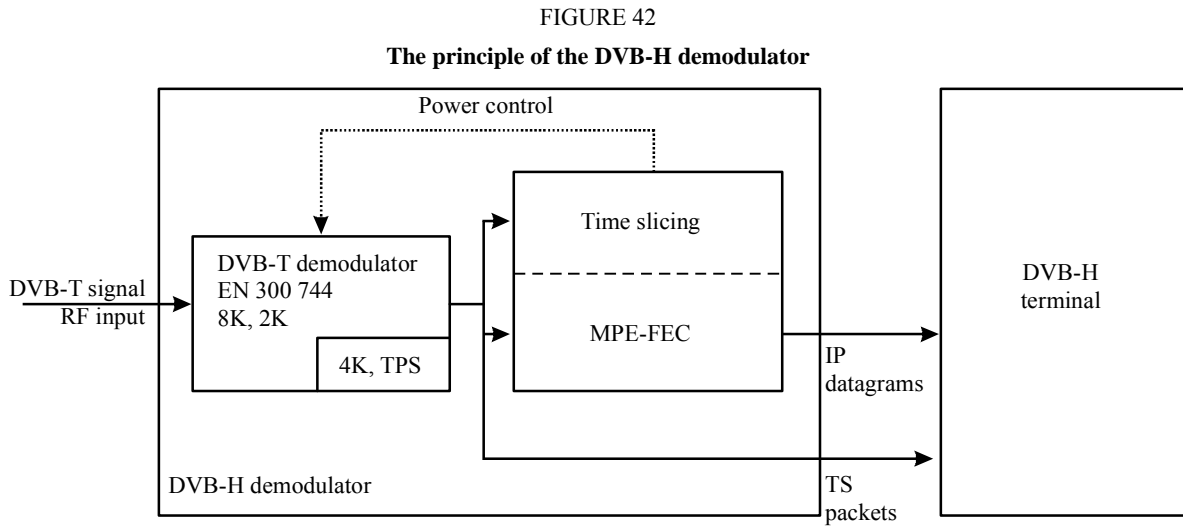

## 2.2 The end-to-end system topology

To illustrate the DVB-H system's ability to share a MUX with traditional MPEG-2 TV services please refer to Fig. 43.

IP packets are fed into the DVB-H IP encapsulator and converted to MPE encapsulated and time-sliced DVB-H transport stream (TS), which is sharing the MUX as shown.

The resulting TS is delivered to the DVB-T modulator (offering 2K, 4K, and 8K modes with corresponding DVB-H TPS signalling) and modulated onto the RF carrier.

The DVB-T demodulator detects the transmission mode and the TPS bit section. The output TS is presented to the DVB-H IP decapsulator, extracting the original IP packet stream.

FIGURE 43

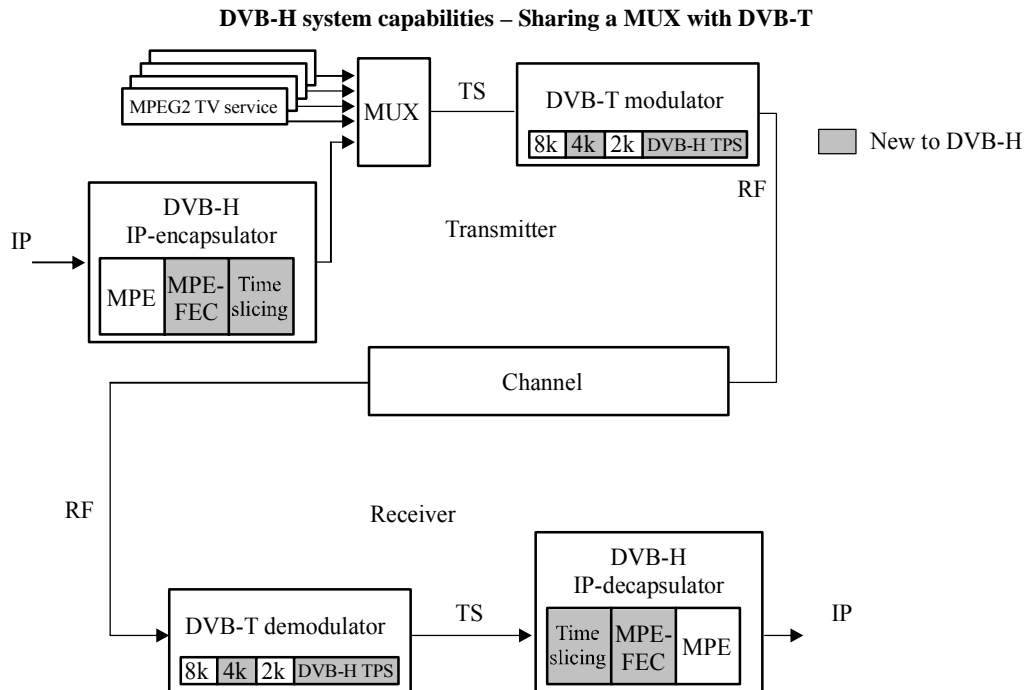

Report 2049-43

### 2.3 IP-based mobile broadcast services systems with DVB-H

ETSI has specified an end-to-end mobile broadcast services system “IP Datacast over DVB-H” for delivery of any types of digital content and services using IP-based mechanisms optimized for devices with limitations on computational resources and battery. It consists of a unidirectional DVB-H broadcast path that may be combined with a bidirectional mobile cellular (2G/3G) interactivity path.

Open Mobile Alliance (OMA) organization has also specified an end-to-end mobile broadcast services system solution for handheld receivers. The OMA BCAST specifications are paying a specific attention to the broadcast bearer-independent technology enablers to enable the convergence of services between broadcast and mobile domain. Deployment of both the broadcast and mobile cellular (interaction) channels for the delivery of services information and services are taken into account. OMA BCAST specifies the adoption of OMA mobile broadcast services system to the DVB-H as an underlying broadcast distribution system.

## 3 Schematic picture of IP datacast over DVB-H system and the application of the mobile phone interaction path

Figure 44 is a general schematic view on the principle of IP based service system over DVB-H. As illustrated, the user of the DVB-H terminal may also interact with the IP based service system by means of the built-in mobile phone circuitry. This interactivity will enable service subscription and pay-per-view requests, user authentication for advanced multimedia service access and so on.



FIGURE 44  
General schematic view on IP Datacast over DVB-H system

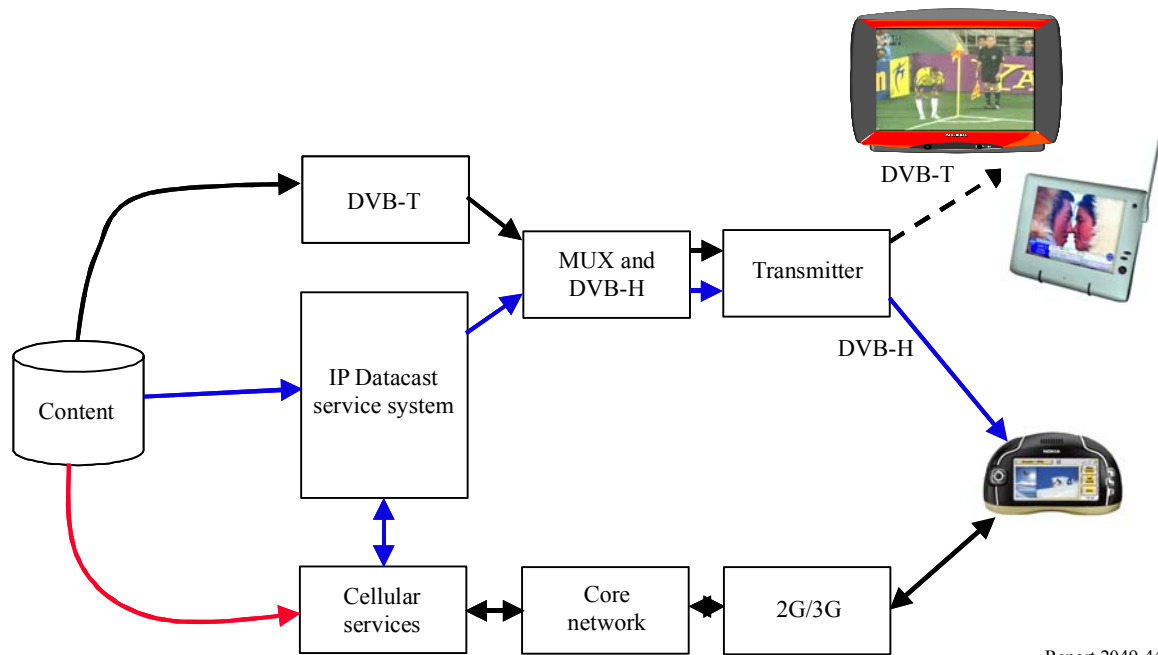

### 3.1 DVB-H commercial deployments

DVB-H standard is deployed in commercial mobile broadcast networks globally.

The first commercial deployments took place in 2006. At April 2009 there are commercial operations based on DVB-H in Europe (Italy, Finland, Netherlands, Austria, Switzerland, Albania), Asia (Vietnam, India, Malaysia, Philippines) and Africa (Morocco, Nigeria, Kenya, Namibia and Ghana).

The number of DVB-H Mobile TV subscribers exceeds one million.

Further commercial launches are planned in Europe (for Poland, Czech, France, Germany, Hungary, Ireland, Russia), in APAC (for Indonesia, Taiwan(Province of China), Thailand, Singapore, Australia), in Middle-East (for Qatar, Saudi-Arabia, United Arab Emirates), in Africa (for South Africa, Ivory Coast), and in Latin-America (for Mexico).

IPDC system over DVB-H is currently deployed in Italy, Albania, Nigeria, Kenya, and Namibia. OMA BCAST as the service system solution with DVB-H radio bearer is deployed in all the commercial cases except Albania.

## 4 References

For the detailed description of the DVB-H standard and technologies used, e.g. MPE-FEC and the time-slicing, you may refer to:

- [1] ETSI EN 302 304: "Digital video broadcasting (DVB); transmission system for handheld terminals (DVB-H)".
- [2] ETSI EN 300 744: "Digital video broadcasting (DVB); framing structure, channel coding and modulation for digital terrestrial television".
- [3] ETSI EN 300 468: "Digital video broadcasting (DVB); Specification for service information (SI) in DVB systems".

- [4] ETSI EN 301 192: “Digital video broadcasting (DVB); DVB Specification for data broadcasting”.
- [5] ETSI TS 101 191: “Digital video broadcasting (DVB); DVB mega-frame for single frequency network (SFN) synchronization”.
- [6] ISO/IEC 7498-1: “Information technology – open systems interconnection – basic reference model: The basic model”.

## Appendix 4

### Forward Link Only

#### 1 Abstract

The technical characteristics of the Forward Link Only (FLO) physical layer are described in the context of the identified requirements. The result is a new mobile broadcast technology, known as FLO technology.

Standardization of the FLO technology has been achieved in the Telecommunications Industry Association (TIA) as Standard TIA-1099 and is further coordinated through the FLO Forum, [www.floforum.org](http://www.floforum.org).

Other informative references related the FLO technology performance include:

- TIA-1102: Minimum Performance Specification for Terrestrial Mobile Multimedia Multicast Forward Link Only Devices.
- TIA-1103: Minimum Performance Specification for Terrestrial Mobile Multimedia Multicast Forward Link Only Transmitters.
- TIA-1104: Test Application Protocol for Terrestrial Mobile Multimedia Multicast Forward Link Only Transmitters and Devices.
- TIA-1120: Forward Link Only Transport Specification.
- TIA-1130: Forward Link Only Media Adaptation Layer Specification.
- TIA-1132: Minimum Performance Specification for Terrestrial Mobile Multimedia Multicast Forward Link Only Repeaters.
- TIA-1146: Forward Link Only Open Conditional Access (OpenCA) Specification.
- FLO technology is designed specifically for mobility applications to meet global market demands for wireless multimedia services. It was designed from inception for the efficient and economical distribution of multimedia content to millions of subscribers.

#### 2 Introduction

The capability of a cellular phone has increased dramatically over the past few years. A device that was originally conceived as a voice-only instrument has steadily evolved into a multi-purpose text and multimedia device.

The advent of video and other rich multimedia services began on a cellular phone has been primarily delivered via existing 3G wireless networks infrastructure. Until recently this delivery was primarily via unicast wireless networks, although the availability of multicast methods within the existing unicast networks is increasing.

The broadcast-multicast mechanisms of these 3G networks are auxiliary to the existing unicast physical layer and can provide a small number channels for multimedia services. For simultaneous wide distribution of content, typically beyond a few users per sector, it is generally sometimes accepted as economically advantageous to transition to broadcast/multicast delivery.

While the cost reduction that can be achieved by a broadcast mode within a unicast framework can be important, far greater efficiencies can be achieved by a dedicated broadcast-multicast overlay. Freed from the restrictions imposed by support for unicast operation, a physical layer can be designed specifically for the purpose of delivering multimedia and applications to an unlimited number of users at the lowest possible cost.

The following sections provide the key air interface characteristics of the FLO technology.

### 3 FLO system architecture

A FLO system is comprised of four subsystems namely Network Operation Centre (NOC-which consists of a National Operation Centre and one or more Local Operation Centres), FLO transmitters, IMT-2000 networks, and FLO-enabled devices. Figure 45 is a schematic diagram of an example of FLO system architecture.

FIGURE 45

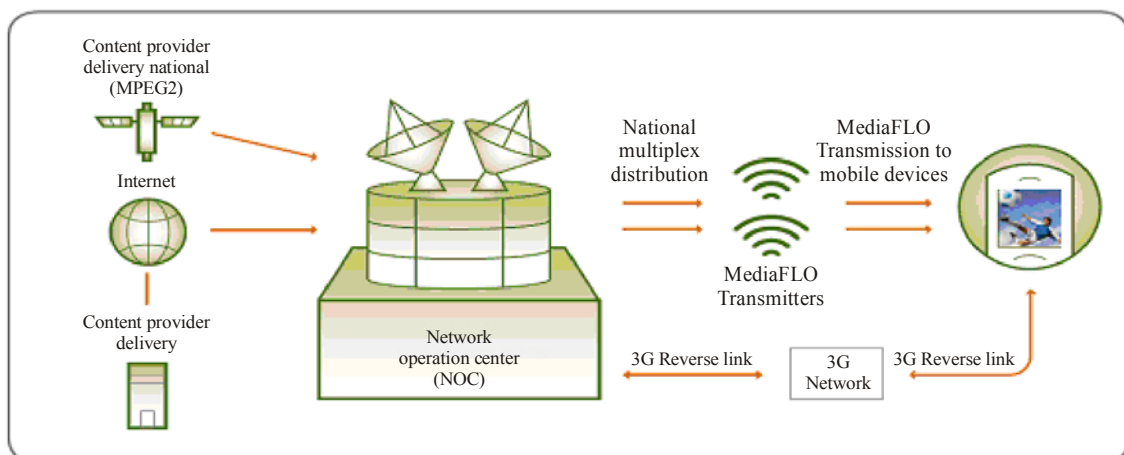

Report 2049-45

#### 3.1 Network Operation Centre

The Network Operation Centre consists of a central facility(s) of the FLO network, including the National Operation Centre (NOC), also referred to as Wide area Operation Centre (WOC), and one or more Local Operation Centres (LOC). The NOC can include the billing, distribution, and content management infrastructure for the network. The NOC manages various elements of the network and serves as an access point for national and local content providers to distribute wide area content and programme guide information to mobile devices. It also manages user service subscriptions, the delivery of access and encryption keys and provides billing information to cellular operators. The Network Operation Centre may include one or more LOCs to serve as an access point for local content providers to distribute local content to mobile devices in the associated market area.

### 3.2 FLO transmitters

Each of these transmitters transmits FLO waveforms to deliver content to mobile devices. FLO transmitters use most of the functions which exist on commercial broadcast transmitters (filter, power amplifier, etc.).

### 3.3 IMT-2000 network

The IMT-2000 network supports interactive services and allows mobile devices to communicate with the NOC to facilitate service subscriptions and access key distribution. In addition to cellphones, FLO has also been demonstrated on a wide variety of personal media players, portable laptops, and automotive entertainment system devices.

### 3.4 FLO-enabled devices

These devices are capable of receiving FLO waveforms containing content services and programme guide information. FLO-enabled devices are primarily cellphones: multipurpose devices that serve as telephones, address books, Internet portals, gaming consoles, etc. FLO technology strives to optimize power consumption through intelligent integration on the device and optimized delivery over the network.

## 4 FLO system overview

### 4.1 Content acquisition and distribution

In a FLO network, content that is representative of a linear real-time channel is received directly from content providers, typically in MPEG-2 format, utilizing off-the-shelf infrastructure equipment. Non-real-time content is received by a content server, typically via an IP link. The content is then reformatted into FLO packet streams and redistributed over a single or multiple frequency network (SFN or MFN) depending on spectrum allocation. The transport mechanism for the distribution of this content to the FLO transmitter may be via satellite, fibre, etc.

At one or more locations in the target market, the content is received and the FLO packets are converted to FLO waveforms and radiated out to the devices in the market using FLO transmitters. If any local content is provided, it would be combined with the wide area content and radiated out as well. Only users subscribed to the service may receive the content. The content may be stored on the mobile device for future viewing, in accordance with a service programme guide, or delivered in real-time for live streaming to the user device given a linear feed of content. Content may consist of high quality video (QVGA) and audio (MPEG-4 HE-AAC<sup>13</sup>) as well as IP data streams. An IMT-2000 cellular network or reverse communication channel may be required to provide interactivity and facilitate user authorization to the service.

### 4.2 Multimedia and data applications services

A reasonable FLO-based programming line-up for up to 30 frames/s QVGA video with stereo audio in a single 8 MHz bandwidth frequency allocation can include up to 28 to 32 real-time streaming video channels of wide area content including some real-time streaming video channels of local market specific content (based on an 16QAM 1/3 mode at 9.9 dB SNR in the UHF 700 MHz band). The allocation between local and wide area content is flexible and can be varied during the course

---

<sup>13</sup> High Efficiency AAC (HE-AAC) audio profile is specified in "ISO/IEC 14496-3:2001/AMD 1:2003" and is accessible through the ISO/IEC website. The performance of the HE-AAC profile coder is documented in the publicly available formal verification test report WG 11 (MPEG) N 6009.

of the programming day, if desired. In addition to wide area and local content, a large number of IP data channels can be included in the service delivery.

### 4.3 Power consumption optimization

The FLO technology simultaneously optimizes power consumption, frequency diversity, and time diversity without compromise. Other similar systems optimize one or two of these parameters, but ultimately compromise on the others. FLO has a unique capability that allows it to access a small fraction of the total signal transmitted without compromising either frequency or time diversity. As a result of these considerations, it is expected that a FLO-enabled mobile device can achieve comparable battery life to a conventional cellular phone; that is, a few hours of viewing and talk time and a few days of standby time per battery charge.

The FLO air interface employs time division multiplexing (TDM) to transmit each content stream at specific intervals within the FLO waveform. The mobile device accesses overhead information to determine which time intervals a desired content stream is transmitted. The mobile device receiver circuitry powers up only during the time periods in which the desired content stream is transmitted and is powered down otherwise. The receiver ON/OFF duty cycle is expected to be relatively low or immaterial, depending on the media content size and data rate used.

FLO technology minimizes programme channel acquisition time. In most cases, it is less than 2 s. Mobile users can channel surf with the same ease as they would with digital satellite or cable systems at home providing a high quality experience comparable to traditional television viewing.

### 4.4 Wide and local area content

As shown in Fig. 46 FLO supports the coexistence of local and wide area coverage within a single radio frequency (RF) channel. When utilizing a SFN, it eliminates the need for complex handoffs for coverage areas. The content that is of common interest to all the receivers in a wide area network is synchronously transmitted by all of the transmitters. Content of regional or local interest can be carried in a specific market. This per market control is central in offering the ability to blackout and retune based on any contractual obligations associated with specific programming.

FIGURE 46

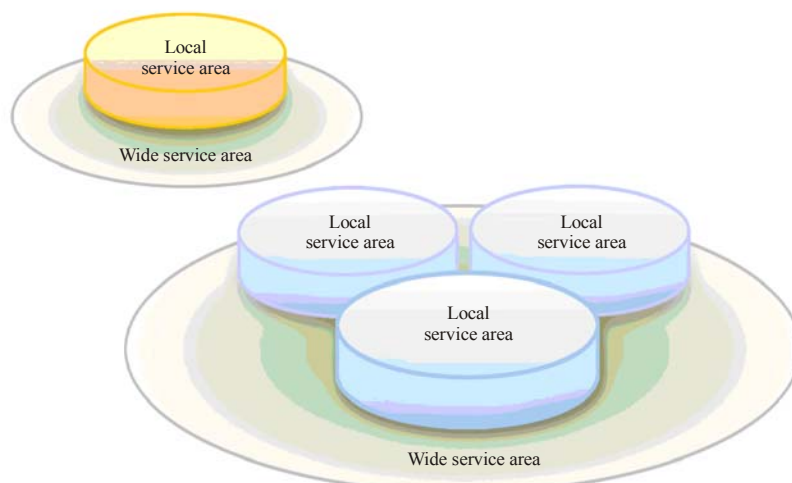

## 4.5 Layered modulation

To increase quality of service, FLO technology supports the option to use a layered modulation technique. With layered modulation, the FLO data stream is divided into a base layer that all users can decode, and an enhancement layer that users with a higher signal-to-noise ratio (SNR) can also decode. The majority of locations will be able to receive both layers of the signal. The base layer has superior coverage as compared to non-layered mode of similar total capacity. The combined use of layered modulation and source coding allows for graceful degradation of service and the ability to receive in locations or speeds that could not otherwise have reception. For the end user, this efficiency means that a FLO network can provide a better coverage with good quality services, especially video, which requires significantly more bandwidth than other multimedia services.

## 5 FLO air interface

### 5.1 Protocol reference model

The FLO air interface protocol reference model is shown in Fig. 47. The FLO air interface specification covers protocols and services corresponding to OSI<sup>14</sup> Layers 1 (physical layer) and Layer 2 (data link layer) only. The data link layer is further subdivided into two sub-layers, namely, medium access (MAC) sub-layer and stream sub-layer.

FIGURE 47

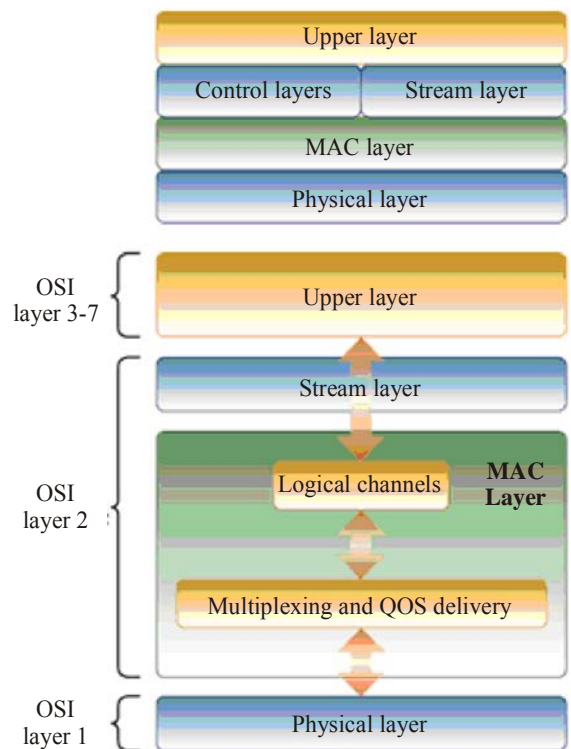

Report 2049-47

<sup>14</sup> The International Standard Organization's Open System Interconnect (ISO/OSI) model.

### 5.1.1 Key features of upper layers

- Compression of multimedia content
- Access control to multimedia
- Content and formatting of control information.

The FLO air interface specification does not specify the upper layers to allow for design flexibility in support of various applications and services. These layers are only shown to provide context.

### 5.1.2 Key features of stream layer

- Multiplexes up to three upper layer flows into one logical channel
- Binding of upper layer packets to streams for each logical channel
- Provides packetization and residual error-handling functions.

### 5.1.3 Key features of Medium Access Control (MAC) layer

- Controls access to the physical layer
- Performs the mapping between logical channels and physical channels
- Multiplexes logical channels for transmission over the physical channel
- Demultiplexes logical channels at the mobile device
- Enforces quality of service (QoS) requirements.

### 5.1.4 Key features of physical layer

- Provides channel structure for the forward link
- Defines frequency, modulation and encoding requirements

## 5.2 FLO air interface fundamentals

### 5.2.1 OFDM modulation

The FLO technology utilizes orthogonal frequency division multiplexing (OFDM), which is also utilized by digital audio broadcasting<sup>15</sup> (DAB), terrestrial digital video broadcasting<sup>16</sup> (DVB-T), and terrestrial integrated services digital broadcasting<sup>17</sup> (ISDB-T). OFDM, as depicted in Fig. 48 can achieve high spectral efficiency while effectively meeting mobility requirements in a large cell SFN.

---

<sup>15</sup> Digital Audio Broadcasting system as defined in Recommendation ITU-R BS.1114 System A/Eureka 147.

<sup>16</sup> Terrestrial Digital Video Broadcasting (DVB-T) as defined in Recommendation ITU-R BT.1306 System B.

<sup>17</sup> ISDB family includes System C of Recommendation ITU-R BT.1306, System F of Recommendation ITU-R BS.1114 and ISDB-S of Recommendation ITU-R BO.1408.

FIGURE 48

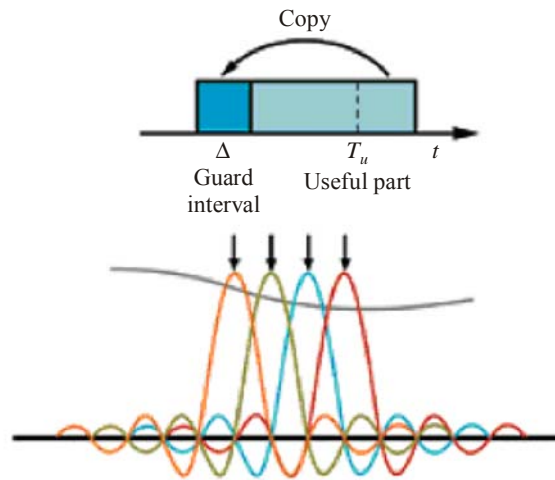

Report 2049-48

The smallest transmission interval corresponds to one OFDM symbol period as shown in Fig. 48. OFDM can handle long delays from multiple transmitters with an appropriate length of cyclic prefix; a guard interval added to the front of the symbol (which is a copy of the last portion of the data symbol) to ensure orthogonality and prevent inter-carrier interference. As long as the length of this interval is longer than the maximum channel delay, all reflections of previous symbols are removed and the orthogonality is preserved.

OFDM is a modulation technique in that it enables user data to be modulated onto the tones, or subcarriers. For each OFDM symbol duration, information carrying symbols are loaded on each tone. The information is modulated onto a tone by adjusting the tone's phase, amplitude or both. In the most basic form, a tone may be present or disabled to indicate a one or zero bit of information – either quadrature phase shift keying (QPSK) or quadrature amplitude modulation (QAM) is typically employed. FLO air interface supports the use of QPSK, 16-QAM and layered modulation techniques. Non-uniform 16-QAM constellations (two layers of QPSK signals) with 2 bits applied per layer are utilized in layered modulation.

A key factor in the design of OFDM systems is the size of the transform – the number of separately modulated sub-carriers in each symbol. For typical deployments, the FLO physical layer uses a 4K mode (yielding a transform size of 4 096 sub-carriers). This mode provides better mobile performance than an 8K mode but still retains a sufficiently long guard interval to be useful in fairly large SFN cells. Robust performance can then be maintained to greater than 200 km/h with graceful degradation beyond. This is supported by the FLO pilot structure (used for channel estimation) which enables receivers to handle delay spreads greater than the cyclic prefix.

OFDM is a modulation technique in that it enables user data to be modulated onto the tones, or subcarriers. For each OFDM symbol duration, information carrying symbols are loaded on each tone. The information is modulated onto a tone by adjusting the tone's phase, amplitude or both. In the most basic form, a tone may be present or disabled to indicate a one or zero bit of information – either quadrature phase shift keying (QPSK) or quadrature amplitude modulation (QAM) is typically employed. FLO air interface supports the use of QPSK, 16-QAM and layered modulation techniques. Non-uniform 16-QAM constellations (two layers of QPSK signals) with 2 bits applied per layer are utilized in layered modulation.



### 5.2.2 Physical layer characteristics

Rapid channel acquisition is made possible by optimized pilot and interleaver structure design. The interleaving schemes incorporated in the FLO air interface simultaneously assure time diversity. The pilot structure and interleaver designs optimize channel utilization without burdening the user with long acquisition times.

FLO transmitted signals are organized into super frames. Each super frame is comprised of four frames of data including the time division multiplexing (TDM) pilots, the overhead information symbols (OIS), and frames containing wide area and local area data. The TDM pilots are provided to allow rapid acquisition of the OIS. The OIS describes the location of the data for each media service in the super frame. The structure of a super frame is shown in Fig. 49.

FIGURE 49

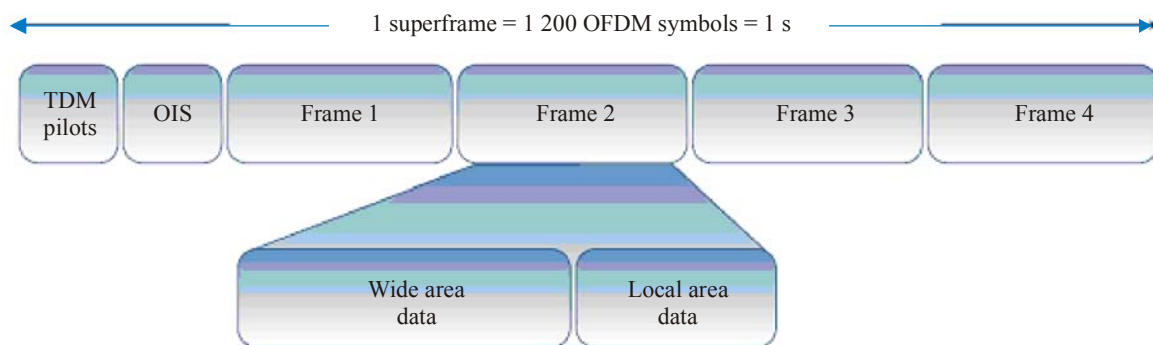

Report 2049-49

Each super frame consists of 200 OFDM symbols per MHz of allocated bandwidth; that is, 1 200 symbols for 6 MHz and each symbol contains seven interlaces of active sub-carriers. Each interlace is uniformly distributed in frequency, so that it achieves the full frequency diversity within the available bandwidth. These interlaces are assigned to logical channels that vary in terms of duration and number of actual interlaces used. This provides flexibility in the time diversity achieved by any given data source. Lower data rates can be assigned fewer interlaces to improve time diversity, while higher data rate channels utilize more interlaces to minimize the radio's on-time and reduce power consumption. Both frequency and time diversity can be maintained without compromising acquisition time.

FLO logical channels are used to carry real-time (live streaming) content at variable rates to obtain statistical multiplexing gains possible with variable rate codecs. Each logical channel can have different coding rates and modulation to support various reliability and QoS requirements for different applications. The FLO multiplexing scheme enables device receivers to just demodulate the content of the single logical channel it is interested in to minimize power consumption. Mobile devices can demodulate multiple logical channels concurrently to enable video and associated audio to be sent on different channels.

### 5.2.3 Error correction and coding techniques

FLO incorporates an iterated short convolutional turbo inner code<sup>18</sup> and a Reed Solomon (RS)<sup>19</sup> outer code. Each inner code packet contains a cyclic redundancy check (CRC). The RS code need not be calculated for data that is correctly received which, under favourable signal conditions, results in additional power savings.

As described in the system overview section above, FLO technology supports the use of layered modulation. A given application may divide a data stream into a base layer that all users can decode, and an enhancement layer that users with higher  $S/N$  can also decode. Due to the point-to-multipoint (broadcast) only nature of the FLO waveform, the majority of devices will receive both layers of the signal, with the base layer having superior coverage and equivalent total capacity mode. Outer and inner coding is performed independently for base and enhancement layer.

Outer and inner coding is performed independently for base and enhancement layer, which provides adjustment to the relative thresholds of each layer and adjusts the ratio of bandwidths.

### 5.2.4 Bandwidth requirements

The FLO air interface is designed to support frequency bandwidths of 5, 6, 7, and 8 MHz, depending on the availability of appropriate broadcasting and/or mobile spectrum and existing channel block sizes. A highly desirable service offering can be achieved with a single RF channel. In some regions, the 5 MHz allocations provided for time division duplex (TDD) application may also be applied to mobile media distribution.

FLO air interface supports a broad range of data rates ranging from 0.47 to 1.87 bit/s/Hz. In a 6 MHz channel, the FLO physical layer can achieve up to 11.2 Mbit/s at this bandwidth. The different data rates available enable tradeoffs between coverage and throughput.

### 5.2.5 Transport mechanisms

FLO incorporates effective means for the transport of packets depending on the type of content. IP is used when IP has a quantifiable advantage such as in the delivery of non-real-time content or data (text and graphics). Real time streaming media is delivered directly to a sync layer that is designed to minimize the impact of lost packets in streaming media. One of the FLO design objectives is to maximize efficiency by eliminating cascading multiple protocols. This results in more capacity being available for media, which minimizes power consumption since receiving fewer total bits saves power. The FLO transport protocol stack is illustrated in Fig. 50.

---

<sup>18</sup> Turbo codes are a class of recently-developed high-performance error correction codes finding use in deep-space satellite communications and other applications where designers seek to achieve maximal information transfer over a limited-bandwidth communication link in the presence of data-corrupting noise.

<sup>19</sup> Reed-Solomon codes are block-based error correcting codes with a wide range of applications in digital communications and storage.

FIGURE 50

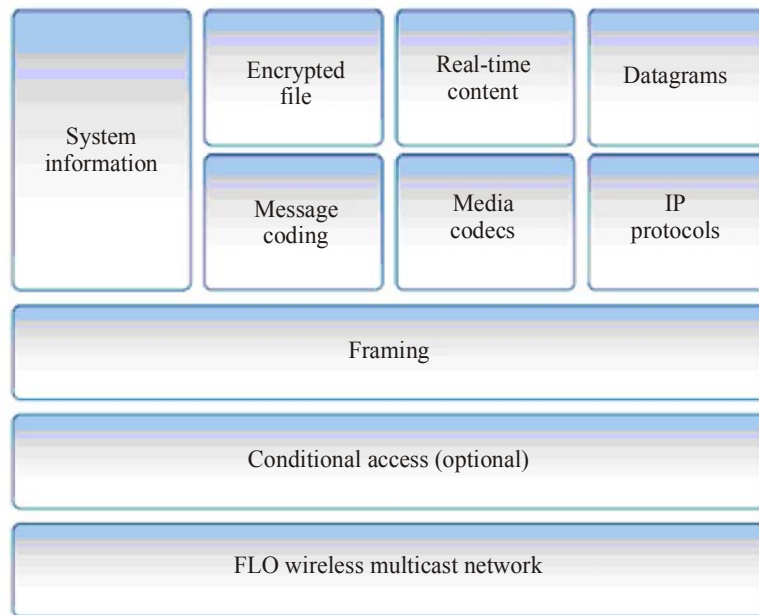

Report 2049-50

## 6 Candidate frequency bands

FLO may be deployed in a number of frequency bands utilizing various bandwidths and transmit power levels. The relative performance of a given modulation mode is defined by the choice of modulation, turbo, and RS code rates.

The frequency bands that are suitable for multicast distribution, including FLO technology, are similar to those utilized for point-to-point (unicast) wireless IP and voice. These range from 450 MHz to 3 GHz. Higher frequency bands may require a greater SNR due to increased Doppler.

The characteristics of this spectrum for transmission to a device are well understood. A significant difference for video reception is that the device is not placed against the head but held in the hand at low height and in a pedestrian indoor environment. The UHF band, in view of its channelization (6, 7, 8 MHz), its technical characteristics (downlink only services, high power level, low network density), as well as the compromise it provides between antenna electrical length and signal propagation, has generally been considered as the optimal spectrum for mobile broadcast applications.

In order to maximize coverage area per cell and minimize the cost per bit delivered to the user, the design of a network supporting multimedia services benefits from higher power levels than are typically licensed for wireless voice and data applications. As an example, in the United States of America, the Federal Communications Commission (FCC) assigned licenses for 698-746 MHz in 6 MHz blocks for a variety of broadcasting, mobile and fixed services, allowing for a maximum transmit power level of 50 kW e.r.p. in particular for the unpaired 6 MHz channels 55 and 56. FLO is today deployed on channel 55 across the United States. This spectrum offers significant advantages in terms of coverage per transmitter, which translates to significant infrastructure cost savings.

Similar service coverage can be achieved in other regions of the world where the appropriate spectrum allocation and the service rules support broadcasting multimedia and data applications for mobile reception.

## 7 Conclusion

With the updates made to the FLO technology, the broad delivery of wireless multimedia services is now more economical, more efficient, and more accessible than ever before. FLO technology was designed from inception to meet global market demands for wireless multimedia services. The result is that wireless subscribers have greater access to better multimedia services.

Implementation of FLO technology via a single frequency FLO network provides the link between technical feasibility and economic viability, offering an excellent delivery mechanism for providing multimedia content to wireless users. FLO technology is designed to work in combination with the existing cellular data networks to drive additional demand through new innovative interactive services.

## Appendix 5

### **Digital mobile narrow-band multimedia broadcasting system AVIS (audiovisual information system)**

#### 1 Abstract

The question about utilization of digital techniques in the frequency band 87-108 MHz with the aim of increasing the efficiency of utilization of this band becomes very actual at present.

One way to increase utilization efficiency of this band with preserving of the frequency channels allocation is the substitution of frequency modulation by digital techniques with the purpose of transmission of some high-quality stereo sound programmes or a video stream of VHS-quality with suitable stereophonic accompaniment and/or other multimedia information.

A digital terrestrial broadcasting system for mobile reception has been created in the Russian Federation. This system was denoted by AVIS (audiovisual information system). AVIS uses the band 87-107 MHz among other bands.

#### 2 Main facilities

The system AVIS enables to transmit 15-17 high quality stereo sound programmes or a video stream of CIF (352\*288) size with suitable stereophonic accompaniment using one 200 or 250 kHz bandwidth frequency channel. The system AVIS designed for reception with vehicular and portable receivers.

The frequency range, used by AVIS for broadcasting, enables to locale broadcasting, i.e. one and the same carrier frequency may be used for broadcasting of distinct programmes in distinct cities. At the same time the coverage radius of the transmitter is large enough to provide reception in remote places where broadcasting is impossible otherwise.

AVIS enables stable reception of the signal in a moving vehicle with standard flagpole antennas under urban condition with compact planning, multipath propagation and absence of direct vision of transmitter antenna and also in cross-country areas, in mountainous areas and in stocked forestland.

A receiver of the system should enable to receive new digital programmes and programmes from analogue FM-broadcasting station with automatic detection of the programme type. It is possible to

provide the receiver with the opportunity to receive on-air programmes in the standards of DVB-H and DVB-T.

### 3 Technical aspects of AVIS

#### 3.1 Audio and video codecs

The studies of the developed software video (H.264/AVC) and audio (HE-AAC) codecs have shown its high efficiency. The quality of decoded image is nearly equal to or better than the quality of a analogue home videotape recorder (VHS) if the bit rate of the digital stream is equal to 384-512 kbit/s and the quality of the sound is nearly equal to the quality of FM-programmes if the bit rate of digital audio stream is equal to 24 kbit/s.

#### 3.2 Content

Table 13 contains preferable audio/video formats for all combinations of guard interval, QAM constellation and code rate.

TABLE 13

**Preferable audio/video formats for 250 kHz channel bandwidth**

Constellation	Code rate	Guard interval					
		1/4			1/8		
		Usable bit rate (kbit/s)	Video format and frame rate (fps)	Audio format and bit rate (kbit/s)	Usable bit rate (kbit/s)	Video format and frame rate (fps)	Audio format and bit rate (kbit/s)
QPSK	1/2	170	–	5*32, stereo	190	–	6*32, stereo
			QCIF, 12.5	24, stereo		QCIF, 12.5	24, stereo
QPSK	2/3	220	–	6*32, stereo	250	–	7*32, stereo
			QVGA, 12.5	32, stereo		QVGA, 12.5	32, stereo
QPSK	3/4	250	–	7*32, stereo	280	–	8*32, stereo
			QVGA, 12.5	32, stereo		QVGA, 12.5	32, stereo
16-QAM	1/2	330	–	10*32, stereo	370	–	11*32, stereo
			CIF, 12.5	32, stereo		CIF, 12.5	32, stereo
16-QAM	2/3	450	–	14*32, stereo	490	–	15*32, stereo
			CIF, 25	48, stereo		CIF, 25	48, stereo
16-QAM	3/4	500	–	15*32, stereo	560	–	17*32, stereo
			CIF, 25	48, stereo		CIF, 25	48, stereo

#### 3.3 Channel coding

The essential difference of the channel encoder subsystem of AVIS from the corresponding subsystem DVB-T (DVB-H) is the ability of using not only the convolution code defined in DVB-T but also an additional convolution code (with larger code length). This additional convolution code

enables to apply a multi-threshold decoder, which does not require high processing power. There are supposed the following code rates: 1/2, 2/3 and 3/4.

AVIS uses orthogonal frequency division multiplexing (OFDM) transmission. All data carriers are modulated using either QPSK or 16-QAM constellation. The values of guard intervals may be 1/4 or 1/8.

Figure 51 illustrates the transmitter functional block diagram, containing the channel encoding subsystem and the subsystem of OFDM modulation. Figure 52 illustrates the functional block diagram of AVIS signals receiver.

FIGURE 51  
The transmitter functional block diagram

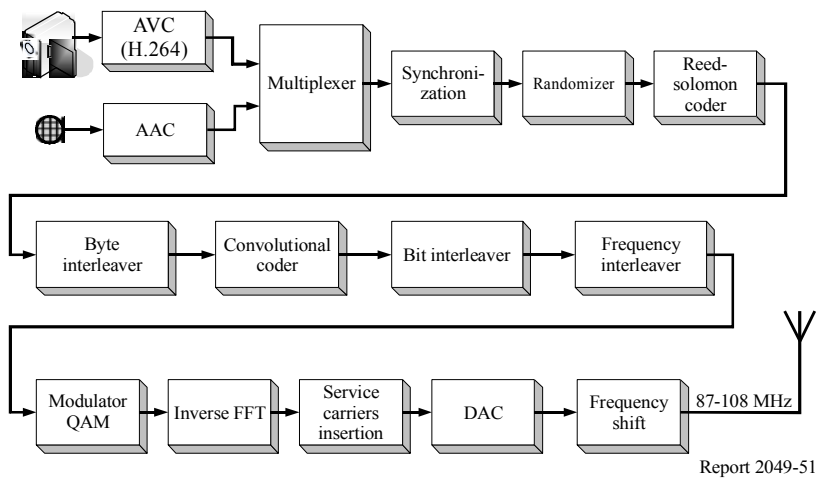

Report 2049-51

FIGURE 52  
The receiver functional block diagram

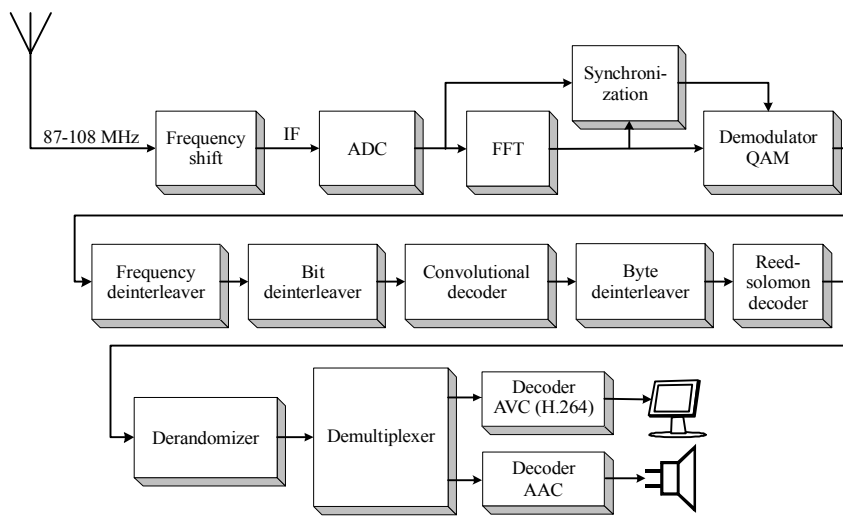

Report 2049-52

Bit rate of useful data stream is defined as follows:

$$\text{Bit rate} = \frac{N_c \times \text{BitsPerCarrier} \times \text{ConvolutionalRate} \times 188/204}{1092 \times 10^{-3} \times (1 + \text{GuardInterval}) \times 10^3} \text{ kbit/s}$$

where:

- BitsPerCarrier: number of bits per data carriers  
 ConvolutionRate: convolution code rate  
 GuardInterval: guard interval  
 $N_c$ : number of data carriers.

### 3.4 Spatial scalability

The application of hierarchical modulation on the transmitter side enables to transmit 2 bits (QPSK) for main stream and 4 bits for additional stream (16-QAM) per each carrier. This transmission method allows reception of the main stream even if the additional stream can not be received because of high level of the noise. For example, audio and video information may be transmitted in main stream and detail information for the video may be transmitted in additional stream. Existing video codecs provide the opportunity of such splitting of video stream.

### 3.5 Frequency channel bandwidth requirements

The bandwidth of the system AVIS is equal to 200 or 250 kHz that corresponds to the channel bandwidth in the chosen broadcasting frequency band.

Notice that in the band 8 (VHF) calculated integral scale of frequency correlation is 0.8-0.9 MHz for many urban areas with modern building in accordance with experimental data. If there is significant quantity of reflective devices along a path, then frequency shift is up to 20-25 kHz. There is good reason to believe that if the distance between adjacent carriers is about 900 Hz and the bandwidth of the channel is 0.20-0.25 MHz, then the conditions of transmission in urban area are comfortable.

### 3.6 Network architecture

The selected frequency band and the selected broadcasting concept have some advantages:

- possibility of utilization of single-frequency network and multi-frequency network;
- broadcasting of 5 or more high-quality stereo sound programmes or a video stream of acceptable quality with a stereo sound accompaniment in a city using only one transmitter;
- ability to localize broadcasting of one programme, i.e. the same frequency is used to broadcast different programmes in various cities.

### 3.7 Testing

In August 2005 an on-air broadcasting test of AVIS has been carried out in Moscow.

There were the following parameters of the transmitted signal:

- Number of OFDM-carriers: 279  
 Constellation: 16-QAM  
 Guard interval: 1/8  
 Convolution code rate: 3/4

Bit rate of useful data:	560 kbit/s
Video format:	352 × 288 (CIF), 25 fps
Bandwidth:	250 kHz

The central frequency of the “Russian Radio” broadcasting station transmitter was equal to 105.7 MHz. The transmission power was lower than 200 W. The stable reception has been realized at a distance of 21.5 km from the transmitter.

The receiver was situated in a car. The signal has been received on a flagpole antenna attached to the roof of the car, and the length of the antenna has been equal to 43 cm.

### 3.8 Simulation

In Table 14 there are some results obtained for three channels models using 16-QAM constellation, 3/4 convolution bit rate and 1/8 guard interval.

TABLE 14  
Threshold values of the signal-to-noise ratio  
for various channel models

Channel model	Threshold values of the SNR (dB)
Gaussian channel	13.5
Gaussian + Ricean channel	14
Gaussian + Rayleigh channel	17

Figure 53 illustrates a frame of video stream shown on the screen of the receiver for the tested mode of the system.

FIGURE 53  
A frame from received video stream



Report 2049-53

The results of the field testing were successful.



TABLE 15

**Usage of physical resources by digital broadcasting systems for mobile reception**

	Digital system AVIS
Bandwidth	200, 250 kHz
Spectrum efficiency (bit/s/Hz)	From 0.668 bit/s/Hz (QPSK 1/2) to 2.227 bit/s/Hz (16-QAM 3/4)

TABLE 16

**Technical performance comparison of digital broadcasting systems for mobile reception in response to the defined user requirements**

User requirements	Digital system AVIS
High quality multimedia for handheld receivers Media type with quality characteristics Resolution Frame rate Bit rate	Video: CIF (352 × 288), QCIF (176 × 144), QVGA (320 × 240), SQVGA (160 × 120) size 12.5 ~ 25 fps, 15 ~ 30 fps Various resolution and frame rates supported Up to ~560 kbit/s Audio: Stereo and mono From 24 kbit/s to 192 kbit/s Data: Binary data, still images, text Typical combination of AV is CIF at 25 fps with 512 kbit/s, and stereo audio 48 kbit/s Video and audio data rates range up to 557 kbit/s for 250 kHz channel bandwidth (445.5 kbit/s for 200 kHz)
Monomedia coding: Video Audio Others	Video: MPEG-4 AVC/H.264 Audio: HE AAC v2 Data format: JPEG, BMP, etc.
Flexible configuration of services: Audio/video Ancillary and auxiliary data	Any combination of real-time audio, video and data broadcast is available Electronic Programme Guide Local broadcast using combination of SFN and MFN
Conditional access	Applicable
Seamless service access	Applicable
Fast discovery and selection of content and services	Electronic Programme Guide support for discovery and selection of services

TABLE 16 (*end*)

<b>User requirements</b>	<b>Digital system AVIS</b>
Stable and reliable reception and QoS control in various types of receiving environments	Use of the following techniques: Code rate of FEC and modulation are selectable RS outer code OFDM (279 subcarriers), Time and frequency interleaving Provides: Variable QoS and robustness High mobility up to 300 km/h Stable reception under urban condition with compact planning, multipath propagation and absence of transmitter direct vision and also in cross-country areas, in mountainous areas and in stocked forestland
	SFN to extend the coverage and local MFN to cover the local services Hierarchical transmission available
Low power consumption in comparison to stationary reception	Narrow bandwidth allows low system clock frequency
Provision of interactive	Supported
Interoperability with mobile telecommunication networks	Support for multimedia data services over mobile telecommunication network
Support for efficient and reliable delivery (transport) mechanism of services	Transport protocol based on MPEG2-TS

TABLE 17

**Specifications for digital broadcasting systems for mobile reception**

		<b>Digital system AVIS</b>
Physical layer		
Encapsulation and protocols for transmission of content		ISO/IEC 13818-1 MPEG-2 systems
Multimedia content format		ISO/IEC 14496-14 (MP4)
Monomedia coding	Audio coding	ISO/IEC 14496-3
	Video coding	ITU-T Rec. H.264 and ISO/IEC 14496-10MPEG-4 AVC
	Others	JPEG, BMP

## Appendix 6

### Implementation of interactivity

#### Digital mobile telephony

Refer to § 2.4.9.1.

#### Interaction channel making use of the broadcast spectrum

This approach has been studied in the past, but major difficulties with global circulation of user equipment capable of transmitting into the broadcast spectrum have so far been a substantial hurdle. The development of a new two-way data transport standard may also delay the progress.

#### Other implementations of a mobile interaction channel

#### Summary of interaction channel methodologies

TABLE 18

General interaction channel methodologies for interactive mobile broadcasting systems

Methodology	Reference standards/Specifications	3GPP/3GPP2 Bearer service	
Mobile telephony	IMT-2000	CDMA Direct Spread	HSDPA (Device Category 10) HSUPA (E-DCH) WCDMA R99
		CDMA Multi Carrier	1X EV-DV Rev D/C 1X EV-DO Rev A CDMA2000 1X
		Other IMT-2000 family members	
	cdmaOne	IS95 Rev A,B	
	Global system for mobile communications (GSM)	GPRS (Device Category 10) EGPRS	
Broadcasting in-band	N/A	N/A	

## Appendix 7

### Acronyms

3GPP	3rd Generation Partnership Project No. 1
3GPP2	3rd Generation Partnership Project No. 2
ARIB	Association of Radio Industries and Businesses (Japan)
ARIB TR	ARIB Technical Report
AU	access unit
AVC	advanced video coding
BCMCS	BroadCast MultiCast Services
BER	bit error rate
BIFS	Binary Format for Scene Description
BSS	broadcasting-satellite service for sound
CAT	conditional access table
CD	compact disc
CDM	code division multiplex
CIF	common interchange format
<i>C/N</i>	carrier-to-noise ratio
CRC	cyclic redundancy check
CTS	composition time stamp
DAB	Digital Audio Broadcasting
DSB	Digital Sound Broadcasting
DTS	decoding time stamp
DVB-H	Digital Video Broadcasting for Handheld devices
DVB-T	Digital Video Broadcasting – Terrestrial
ER-BSAC	Error Resilience – Bit Sliced Arithmetic Coding
e.r.p.	effective radiated power
ES	elementary stream
ESCR	elementary stream clock reference
ESG	Electronic Service Guide
ETSI	European Telecommunications Standards Institute
ETSI EN	ETSI European Norm
ETSI TS	ETSI Technical Specification
FCC	Federal Communications Commission
FEC	forward-error correction
FIC	fast information channel
FLO	Forward Link Only

HE-AAC	High Efficiency Advanced Audio Codec
IDR	instantaneous decoder refresh
IEC	International Electrotechnical Commission
IMT-2000	International Mobile Telecommunications-2000
IOD	initial object descriptor
IP	Internet Protocol
IPDC	Internet Protocol Data Cast
IPI	Intellectual Property Identification
IPMP	Intellectual Property Management and Protection
ISDB-T	Terrestrial Integrated Services Digital Broadcasting
ISO	International Organization for Standardization
LOC	Local Operation Centre
MaxDPB	Maximum Decoded Picture Buffer
MBMS	Multimedia Broadcast Multicast Services
MPE	multi protocol encapsulation
MPEG	Moving Picture Experts Group
MSC	main service channel
MUX	multiplex
MV	motion vector
NOC	National Operation Centre
OD	object descriptor
OFDM	orthogonal frequency division multiplexing
OIS	overhead information symbols
OPCR	Original PCR
OSI	Open System Interconnect model
PAT	Programme Association Table
PC	personal computer
PCR	programme clock reference
PCS	personal communication system
PDA	personal digital assistant
PES	packetized elementary stream
PHY	physical layer
PID	packet identifier
PMT	Programme Map Table
PSI	programme specific information
PTS	presentation time stamp
QCIF	Quarter CIF
QoS	quality of service

QVGA	quarter video graphics array
RF	radio frequency
RS	Reed Solomon
SFN	single frequency network
SI	service information
SL	sync layer
<i>S/N</i>	signal-to-noise ratio
TDD	time division duplex
TDM	time division multiplexing
T-DMB	Terrestrial-Digital Multimedia Broadcasting
TPS	transmission parameter signalling
TS	transport stream
WDF	Wide DMB Format

---