

International Telecommunication Union

ITU-R
Radiocommunication Sector of ITU

Report ITU-R M.2282-0
(12/2013)

**Systems for public mobile
communications with aircraft**

M Series
**Mobile, radiodetermination, amateur
and related satellite services**



International
Telecommunication
Union

Foreword

The role of the Radiocommunication Sector is to ensure the rational, equitable, efficient and economical use of the radio-frequency spectrum by all radiocommunication services, including satellite services, and carry out studies without limit of frequency range on the basis of which Recommendations are adopted.

The regulatory and policy functions of the Radiocommunication Sector are performed by World and Regional Radiocommunication Conferences and Radiocommunication Assemblies supported by Study Groups.

Policy on Intellectual Property Right (IPR)

ITU-R policy on IPR is described in the Common Patent Policy for ITU-T/ITU-R/ISO/IEC referenced in Annex 1 of Resolution ITU-R 1. Forms to be used for the submission of patent statements and licensing declarations by patent holders are available from <http://www.itu.int/ITU-R/go/patents/en> where the Guidelines for Implementation of the Common Patent Policy for ITU-T/ITU-R/ISO/IEC and the ITU-R patent information database can also be found.

Series of ITU-R Reports

(Also available online at <http://www.itu.int/publ/R-REP/en>)

Series	Title
BO	Satellite delivery
BR	Recording for production, archival and play-out; film for television
BS	Broadcasting service (sound)
BT	Broadcasting service (television)
F	Fixed service
M	Mobile, radiodetermination, amateur and related satellite services
P	Radiowave propagation
RA	Radio astronomy
RS	Remote sensing systems
S	Fixed-satellite service
SA	Space applications and meteorology
SF	Frequency sharing and coordination between fixed-satellite and fixed service systems
SM	Spectrum management

Note: This ITU-R Report was approved in English by the Study Group under the procedure detailed in Resolution ITU-R 1.

Electronic Publication
Geneva, 2014

© ITU 2014

All rights reserved. No part of this publication may be reproduced, by any means whatsoever, without written permission of ITU.

REPORT ITU-R M.2282-0

Systems for public mobile communications with aircraft

(2013)

1 Introduction

This Report deals with the general principles, technical characteristics and operational features of terrestrial systems for public mobile communications with aircraft.

2 General operational considerations

The system should be fully compatible and capable of interfacing with the international public switched telephone network, public data network, the Internet, or any combinations thereof.

The system should have adequate bandwidth to meet the foreseeable demand for the services.

The Quality of Service should be that which meets the objectives of the system. For example, if the objective is to provide high quality voice service, then the Quality of Service should be comparable to that of the public switched network (voice and data). If the objective is to provide best-effort Internet type traffic, then typically there are no Quality of Service mechanisms being used, at least for the best-effort traffic.

The system should provide, in so far as possible, uninterrupted coverage throughout the designated service areas with the capability of coordinated operation across national borders.

The airborne equipment must be electromagnetically compatible with other aircraft systems in accordance with appropriate regulatory requirements and should have minimal impact on aircraft engineering, maintenance and operations.

The system must have no adverse influence on the safe operation of the aircraft.

The system should not cause harmful interference to other terrestrial communication systems.

3 System technical characteristics and operational features

Technical characteristics and operational features of the systems for public communications with aircraft in some countries in Region 1 are given in Annex 1.

Technical characteristics and operational features of the systems for public communications with aircraft in some countries in Region 2 are given in Annex 2.

Technical characteristics and operational features of the systems for public communications with aircraft in some countries in Region 3 are given in Annex 3.

Channel propagation effects on a terrestrial air-to-ground system are given in Recommendation ITU-R P.528-3 – Propagation curves for aeronautical mobile and radionavigation services using the VHF, UHF and SHF bands, which provides useful information for design of systems for public mobile communications with aircraft.

Annex 1

Systems for public communications with aircraft in some countries in Region 1

1 Introduction

1.1 Broadband Direct-Air-to-Ground Communications (DA2GC) systems within the European Conference of Postal and Telecommunications (CEPT)

A broadband Direct-Air-to-Ground Communications (DA2GC) system constitutes an application for various types of telecommunication services, such as Internet access and mobile multimedia services, during flights. It aims to provide access to broadband communication services during continental flights on a Europe-wide basis. The connection with the flight passengers' user terminals on-board aircraft is to be realized by already available mobile communication systems on-board aircraft.

The main application field would be Air Passenger Communications (APC). In addition, a broadband DA2GC system could also support Airline Administrative Communications services (AAC) and thus improve aircraft operation, resulting, in particular, in reduced Operational Expenditure (OPEX) for the airlines. Safety-relevant communications such as Air Traffic Control (ATC) and related services are not intended to be covered.

Currently, there is no spectrum designated for broadband DA2GC within CEPT. In order to allow European citizens and airlines to profit from the social and economic benefits of the implementation of such a radio application (intended to provide broadband connectivity between the aircraft and a terrestrial based network), a harmonized spectrum designation within CEPT is important.

Although CEPT has not yet finalized analyses aiming to identify the most suitable frequency band(s) to implement such a system, extensive studies have been carried out on the bands 1 900-1 920 MHz, 2 010-2 025 MHz and 5 855-5 875 MHz.

By taking into account the three systems aiming to provide broadband DA2GC and described in the sections below, CEPT intends to conclude its work by the end of 2014.

2 System 1 identified in ETSI TR 103 054

2.1 System architecture

This broadband DA2GC system is based on 3GPP LTE Rel. 8+ specifications. In particular, synchronization algorithms as well as the maximum Tx power of the On-board Unit (OBU) are to be modified compared to terrestrial mobile radio usage in order to cope with the high Doppler frequency shift caused by aircraft speed and large cell sizes. In addition, the Ground Station (GS) antenna adjustment has to be matched to cover typical aircraft altitudes between 3 and 12 kilometres by adaptation of vertical diagrams including antenna up-tilt. When commercial, this solution will be able to provide in-flight mobile voice and broadband data communication services.

The major building blocks (see Fig. 1 below) of the end-to-end system architecture are:

- service access network infrastructure on-board the aircraft, e.g. WiFi coverage and GSM on-board aircraft (both already standardized and certified for on-board implementation);
- broadband DA2GC network infrastructure on-board aircraft, e.g. modem (OBU), interface to on-board network(s), external antenna, cabling;

- terrestrial radio access network for broadband DA2GC with broadband backhaul links, which would preferably be based on existing infrastructure, but with modifications (e.g. with regard to antenna types and base station implementation) to establish high-performance radio links to aircraft in DA2GC environment;
- mobile core network for session, mobility, subscriber and security management providing IP connectivity to external packet data networks (e.g. intranet, Internet, IMS);
- central network components required for O&M, billing, etc. in the DA2GC network;
- various IP-based service delivery platforms, e.g. for passenger services or for airline or aircraft repair/manufacturer internal applications.

FIGURE 1

System architecture for the broadband DA2GC system as described in ETSI TR 103 054

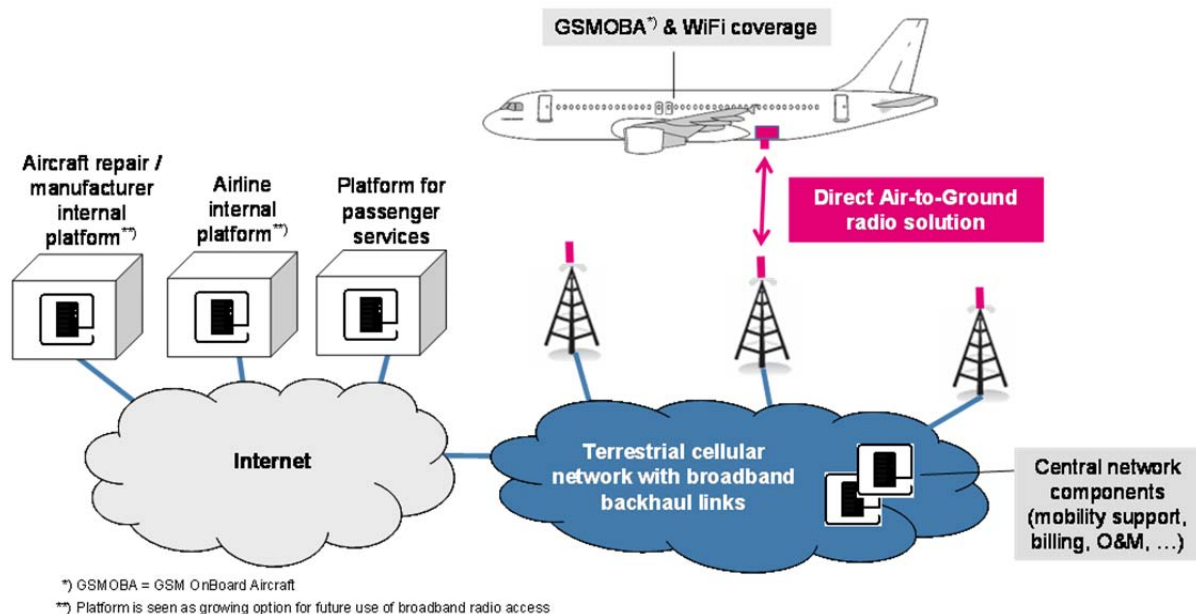

2.2 Spectrum aspects

Paired spectrum of 2×10 MHz for frequency division duplex (FDD) operation is considered necessary to cope with short- to medium-term demand. Unpaired spectrum of 20 MHz for time division duplex (TDD) operation would also be an option, but system performance would slightly suffer due to guard time intervals required for large cell sizes.

Spectrum above 6 GHz is not viewed as appropriate for such an application due to wave propagation aspects (e.g. increased path loss, Doppler shift).

2.3 Test flights

For this system trial flights with prototype equipment were successfully performed in Germany within the 2.6 GHz FDD bands (useable only for trial, but not available for deployment of DA2GC due to planned LTE-deployment for terrestrial cellular mobile) with a signal bandwidth of 2×10 MHz.

Trial set-up details (see Fig. 2):

- Two sites with an inter-site distance of about 100 km were equipped with LTE-based DA2GC GSs consisting of baseband unit (BBU) and remote radio head (RRH) and with

antennas with three sectors (up-tilt), connected with an LTE evolved packet core (EPC) and measurement & data trace servers via a broadband data transport network.

- An Airbus A320 aircraft was equipped with a DA2GC OBU with maximum Tx power of 37 dBm and with two DA2GC antennas below the aircraft fuselage (2 Rx/1 Tx).

FIGURE 2

Trial flight set-up for the broadband DA2GC system as described in ETSI TR 103 054

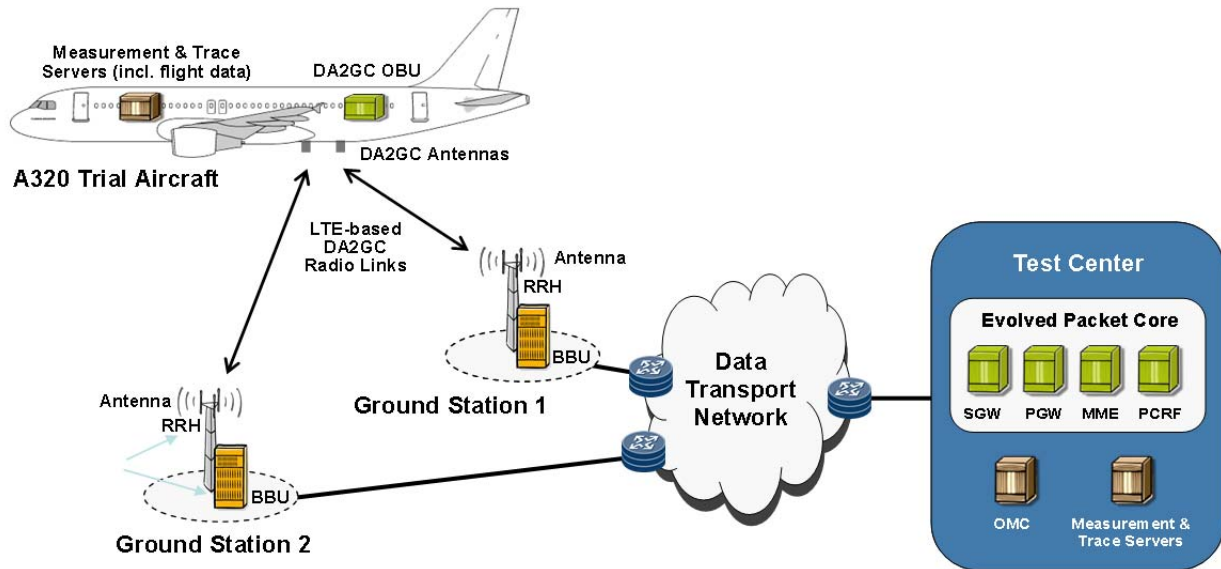

During a 3-hour trial flight, the aircraft flew with speeds between 500 and more than 800 km/h at different altitudes between 4 000 m and 10 000 metres. The flight manoeuvres included phases with inter- and intra-site (sector) handovers as well as phases with large distances to the sites.

Trial results:

- The radio link between the GS and Aircraft Station (AS) was established at distances of more than 100 kilometres from the sites to the aircraft flying at speeds of more than 800 km/h and altitudes up to 10 000 metres.
- Peak data rates of up to 30 Mbit/s in the forward link (ground-to-air) and 17 Mbit/s in the reverse link (air-to-ground) were achieved.
- In addition to high background data traffic, a video conference was established between the teams in the aircraft and the test centre which allowed to follow the flight phases in real time and to demonstrate the low latency of the overall DA2GC system (round-trip time < 50 milliseconds) compared to satellite-based systems.

It should be noted that the GS equipment used (except of antenna adjustment) was basically state-of-the-art LTE-equipment for 2.6 GHz terrestrial cellular mobile deployment. Only the OBU was modified to allow the overall system to work in the aeronautical environment with large cell ranges and high aircraft speeds. The trials showed the very high performance and flexibility of the LTE-based technology even in this early release state.

3 System 2 identified in ETSI TR 101 599

3.1 System architecture

This broadband DA2GC system makes use of adaptive beamforming antennas in order to achieve the desired system performance whilst maintaining lower transmit power levels than would otherwise be necessary. This feature eases co-frequency sharing with other systems by minimizing interference into other services and, at the same time, reducing the impact of incoming interference on the achievable link performance. The decision to use beamforming technology in this broadband DA2GC system implementation was also influenced by the current policy drive in Europe and elsewhere. This recognizes the increasing demand on finite spectrum resources and encourages spectrum sharing through the use of smart technologies, etc.

The overall system connectivity also enables the facility to provide non-safety relevant airline information services whilst maintaining complete isolation between such data and the various Internet and infotainment services available to passengers in the aircraft cabin.

A feature of this broadband DA2GC system is the simultaneous use of four separate integrated radio transceivers/phased array antenna assemblies at the ground station. Such an arrangement enables each ground station to cover the entire visible air space, from horizon to horizon, at all azimuths. Each integrated 8-element antenna array is capable of simultaneously producing multiple co-frequency shaped beams which need to maintain sufficient spatial separation to avoid self-interference, such that three simultaneous beams per sector (or quadrant), or twelve beams per ground station can be assumed operationally. This is shown diagrammatically in Fig. 3 below.

FIGURE 3

Typical ground station antenna arrangement showing three beams per quadrant (simplified depiction)

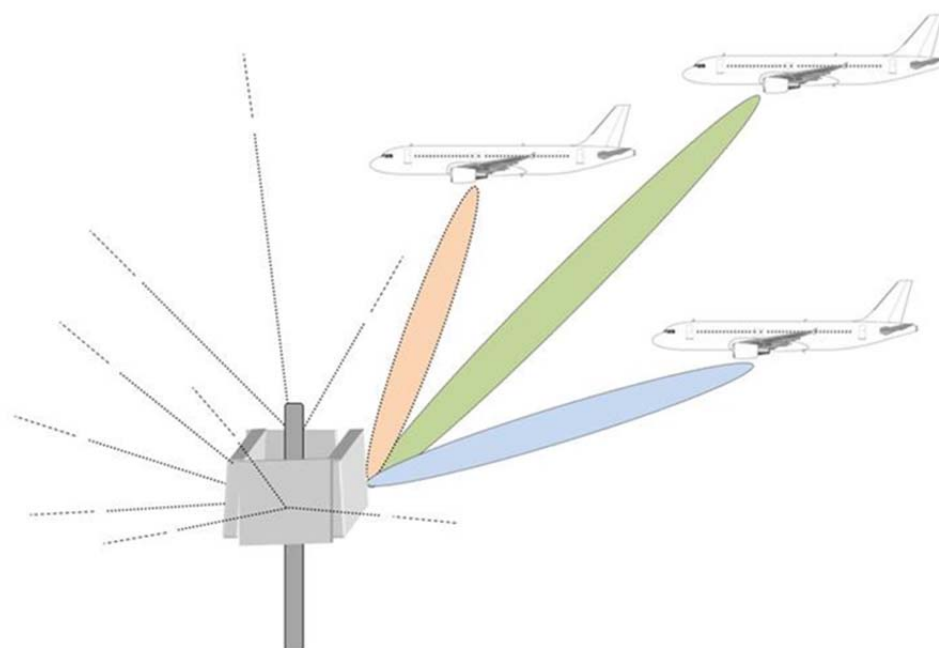

The use of beamforming permits the production of shaped and dynamically steerable beams in both the forward link (ground-to-air) and reverse link (air-to-ground) directions, thereby enabling the desired system performance objectives to be maintained as the aircraft traverses its route whilst,

at the same time, minimizing interference into other co-frequency systems. This is achieved through the benefits of tailored radiation patterns which can be optimized to reduce interference and allow operation at lower transmit powers (on the ground and in the air) than would otherwise be necessary if more conventional fixed antennas were deployed.

In respect of the underlying modulation and coding schemes used, etc., the system uses OFDM/TDMA and has much in common with other existing and proposed mobile broadband backhaul technologies.

3.2 Spectrum aspects

This broadband DA2GC system is currently optimized for use in the frequency bands around 2.4 GHz and 5.8 GHz. However, the technology is capable of operating in any frequency band within the range from 790 MHz to 6 GHz and the system can operate with variable bandwidths in any sub-band within the relevant frequency range. For optimum performance, in TDD mode, the system would require a contiguous block of spectrum of 20 MHz. These spectrum requirements are driven by the need to supply sufficient capacity to serve passengers and crew on-board the aircraft with the desired range of broadband services.

3.3 Test flights

This system has already undergone initial flight testing in the 2.4 GHz and 5.8 GHz bands.

4 System 3 identified in ETSI TR 103 108

4.1 System architecture

This broadband DA2GC system is a UMTS TDD system based on commercial off the shelf equipment that complies with the 3GPP Release 7 standards. A separate frequency converter is used to support operation in the 5 855-5 875 MHz band although operation in other bands has been demonstrated. Signal-in-space characteristics conform to these standards apart from the operating frequency band, Doppler shift compensation, and extended timing advance to accommodate increased range.

Any co-channel interference is minimized using ground station antenna control whereby sectors not required by aircraft at a given time are not illuminated (i.e., the transmitter is inhibited).

The overall end-to-end system architecture of the broadband DA2GC system is illustrated in Fig. 4.

FIGURE 4

System architecture for the broadband DA2GC system as described in ETSI TR 103 108

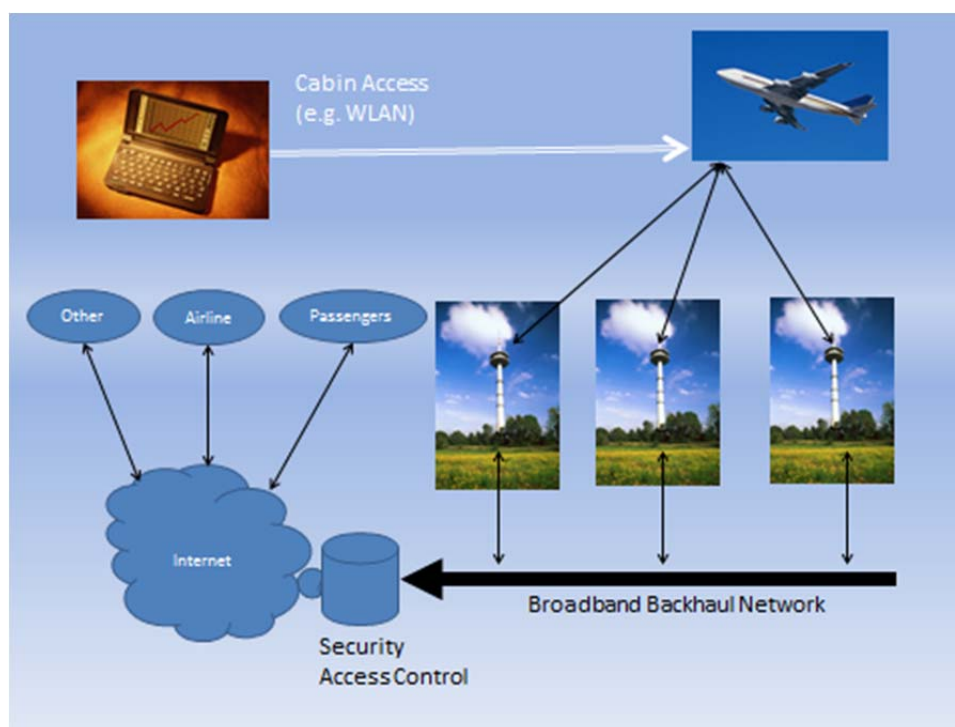

The major building blocks of the end-to-end system architecture, similar to those described in § 2.1, include flight deck and cabin WLAN access, dedicated air/ground IP backhaul and a network control function providing, among other things, security.

4.2 Spectrum aspects

The system can use switch-selectable bandwidths of 5 or 10 MHz. Although single channel operation is possible, the use of additional channels reduces potential inter-cell interference and also any interference to other systems.

The required spectrum is 20 MHz thereby enabling 2×10 MHz or 4×5 MHz channels. The system does not require contiguous spectrum. ETSI TR 103 108 proposes that this system operates in the band 5 855-5 875 MHz. However, the system may operate within the extended band of 790 MHz to 6 GHz, e.g. in the bands 1 900-1 920 MHz and 2 010-2 025 MHz which were designated for terrestrial mobile systems based on UMTS-TDD technology.

4.3 Test flights

A series of test flights using 3G technology have been completed using two turbojet aircraft types. These demonstrated a robust air-to-ground link in different spectrum bands, namely VHF (aeronautical communications), 2 GHz and 5 GHz. Live video from the flight deck and cabin was transmitted to the ground. Simultaneously an international voice call was made by one passenger while another browsed the Internet and watched a streaming video from a ground server. Ranges in excess of 250 km were achieved which is operationally important to maintain coverage over, for example, the Mediterranean Sea.

For certain 5 GHz flights, a modified aircraft marker antenna was used. This included two 5 GHz antenna elements in addition to the marker element itself. This new antenna had the same form and fit as the original, thereby simplifying installation.

Annex 2

Systems for public communications with aircraft in some countries in Region 2

1 System for public communications with aircraft in Canada and United States of America

In Canada¹ and the United States of America², the band pair 849-851 MHz and 894-896 MHz is allocated to the aeronautical mobile service for public correspondence with aircraft. These bands are designated for paired nationwide exclusive assignment to the licensee or licensees of systems providing radio telecommunication services, including voice telephony, broadband Internet and data transmission service, to persons on-board aircraft. However, fixed services and ancillary land mobile services are not permitted.

In Canada and the United States of America, the band plan, described below in Fig. 5, is based on two block pairs: 849-850.5/894-895.5 MHz and 850.5-851/895.5-896 MHz. The band 849-851 MHz is limited to transmissions from ground stations and the use of the band 894-896 MHz is limited to transmissions from airborne stations.

FIGURE 5

The band plan for aeronautical mobile service in Canada and the United States

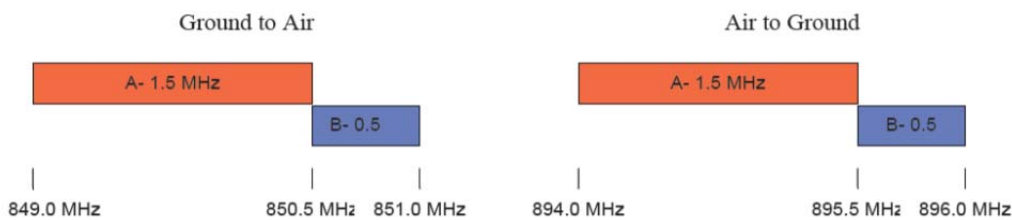

The technical rules for certification and systems deployment in the band in the United States and Canada are technology neutral. The maximum effective radiated power (e.r.p.) limits for ground stations and airborne stations are as follows:

Ground station	500 W e.r.p.
Airborne station	12 W e.r.p.

In the United States of America, the air-to-ground radiotelephone service falls under the U.S. Federal Communications (FCC) Part 22 rules, Subpart G. Commercial aviation air-ground systems may use any type of emission or technology that complies with these technical rules.

2 Safety-of-flight considerations

In addition to the administrations rules governing air-to-ground services, national aviation administration and aircraft operator rules and policies restrict the use of personal electronic devices (PEDs) on aircraft. The use of PEDs, which include wireless telephones, pagers, personal digital assistants, portable music players, video games and laptop computers, remains subject to national

¹ Refer to <http://www.ic.gc.ca/eic/site/smt-gst.nsf/eng/sf09134.html>.

² Refer to: <http://www.gpo.gov/fdsys/pkg/CFR-2010-title47-vol2/pdf/CFR-2010-title47-vol2-part22-subpartG-subjectgroup-id140.pdf>.

aviation administration and aircraft operator authority over in-flight safety. Providers of in-flight wireless broadband and other communications services for transmission using the air-to-ground frequencies must coordinate with airlines and comply with any national administration rules in order to offer such services. Aircraft operators undertake extensive testing and adhere to stringent safety certification protocols when installing and operating communications equipment to ensure that all avionics systems are protected from interference in accordance with national administration rules.

3 An example commercial aviation air-to-ground system operating in the United States consistent with IMT-2000 CDMA multi-carrier as described in Recommendation ITU-R M.1457

3.1 Introduction

This air-to-ground system is currently deployed and operational in continental United States and part of Alaska³. It operates in the 849-850.5 MHz and 894-895.5 MHz bands and offers in-flight broadband services to all Wi-Fi enabled laptops, notebooks and smartphones. It uses a modified version of the IMT-2000 CDMA⁴ Multi-Carrier network to provide a high-speed connection directly from the aircraft to the ground. Some of the characteristics features of this network are: high capacity of 300 kbit/s to 500 kbit/s with peak rates of 3.1 Mbit/s, very large cell size (up to 400 km radius), modifications made to the IMT-2000 CDMA Multi-Carrier1xEV-DO air interface to accommodate extended cell coverage and airplane speed, deployment using off the shelf components such as Radio Access Networks (RANs) and Radio Network Controllers (RNCs).

3.2 System architecture

The overall end-to-end system architecture of this air-to-ground system is illustrated in Fig. 6.

³ <http://www.gogoair.com/gogo/cms/work.do>.

⁴ CDMA2000 High Rate Packet Data Interface Specifications, 3GPP2 C.S0024-A Version 1.0, March.

FIGURE 6

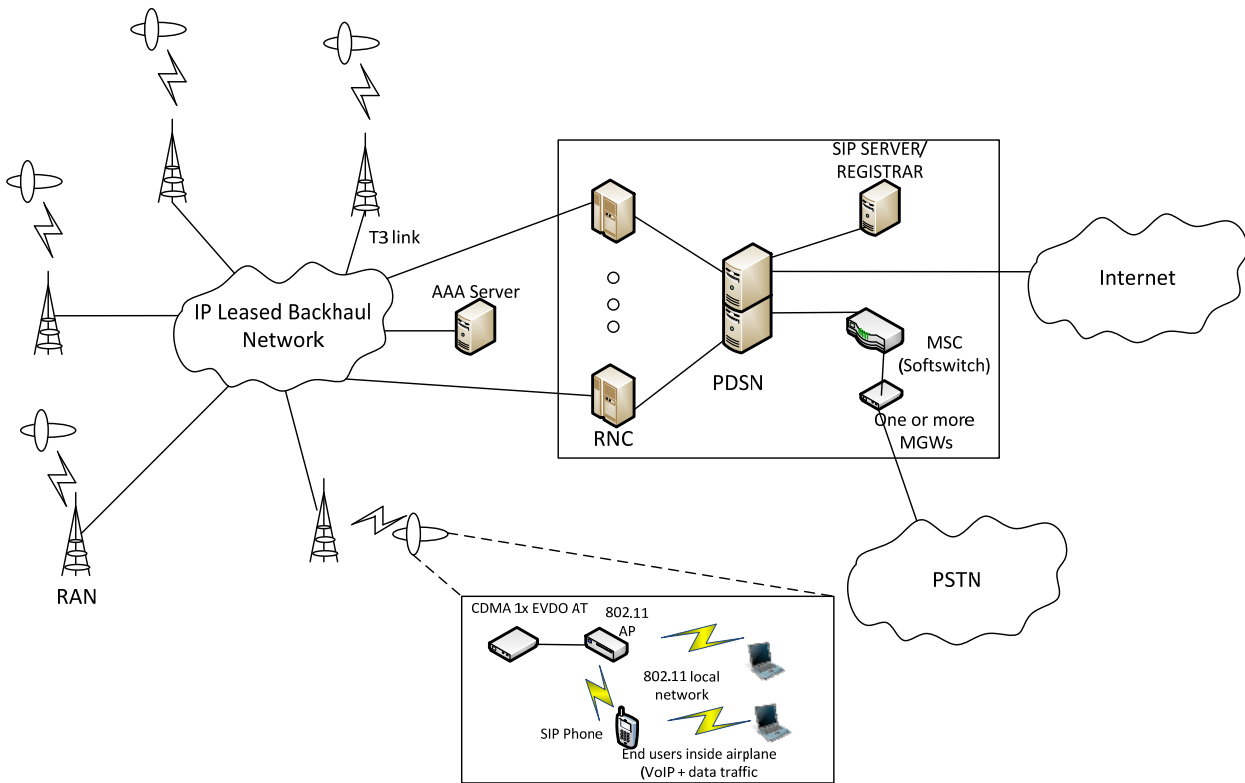
IMT-2000 CDMA multi-carrier air-to-ground system network architecture

Each Radio Access Network (RAN) supports 1 carrier and 6 sectors. Each sector can generate about 2.2 Mbit/s peak throughput. The end users inside the airplane are on a local 802.11 access network connected to an access point (AP). The AP is connected to a 1x EV-DO card, which is the access terminal (AT) for the 1xEV-DO network and a point-to-point protocol (PPP) session is set up between the AT and the PDSN. In addition to data, VoIP can be supported as well. A cabin 2G/3G Picocell can be deployed to allow passengers place and receive voice calls on their own personal cellular phones. The authentication, authorization and accounting (AAA) server, one or more RNCs, packet data serving node (PDSN), media gateways (MGW), Softswitch which controls the MGWs, SIP Server/Registrar can all be co-located in one location.

3.3 Modifications to the IMT-2000 CDMA multi-carrier air-interface

The following sections describe the various enhancements made to the IMT-2000 CDMA multi-carrier 1xEV-DO air interface in order to enable its application as a viable air interface technology for air-to-ground communication.

3.3.1 Expanded range of Doppler shifts

Airplanes travel at speeds far greater than is usual for the operation of cellular mobile units, including high speed trains. For the worst-case orientation of a plane traveling at 340 m/s and at a carrier frequency of 850 MHz, the Doppler frequency shift seen by the airborne access terminal is approximately 964 Hz. When the terminal transmits, the Doppler shift perceived by the base station is approximately doubled to 1 928 Hz. The different searching operations at both the base station and the access terminal needed to be modified to accommodate the extended range of the observed Doppler shifts.

At the base station, the access channel searching algorithm is extended to additional frequency bins that cover the expected Doppler range of the airborne system. Furthermore, in case of handoff searching, when a sector gets added to the access terminal's (AT) active set, the newly added sector needs to search and start demodulating the AT's signal. However, the newly added sector may not be managed by the same base station that was already demodulating the access terminal, and hence the new base station needs to perform the same search procedure that is used for the access channel. When the access terminal tracks one sector and monitors other sectors for handoff, there could be a frequency offset differential due to different Doppler shifts between the serving sector and the candidate sectors. This means that there is an underestimation of the true SINR of the candidate pilot, because the SINR estimator suffers from phase coherence loss due to frequency error. SINR estimation for non-serving sectors needs to be compensated using estimates of Doppler frequency shifts.

3.3.2 Expanded cell radius

The airborne system supports cell radii of up to 400 km. The cell radii for a typical terrestrially-based cellular system are in the order of a few kilometres. In order to cope with large cells, modifications to the baseline reverse link demodulation algorithms are needed. A larger traffic search window is required to search for multipath components, and the multipath search window is extended to 256 chips. The reasoning for this is that the existence of strong multipath components is much more unlikely in the airborne system than in typical terrestrial cellular systems due to radio propagation conditions. Nevertheless, if a signal multipath component were to exist, then the lag difference between the main line-of-sight path and the multipath will most likely be much greater than the few chips (normally less than 10) that is typical in terrestrial communications. For this reason the search window sizes should be extended to 256 chips, corresponding to ~64 kilometres. Furthermore, due to larger cell radii as compared to the conventional terrestrial cellular systems, a much bigger access channel search window is required. If the cell radius is assumed to be R km, then the maximum possible time of arrival difference between two airplanes inside the cell (measured in chips) is given by the following equation.

$$\Delta = 2R * 10^3 \frac{1.2288 * 10^6}{c}$$

where c is the speed of light in m/s. For $R = 400$ km, we obtain $\Delta \sim 3\,333$ chips. This quantity is how large the total access channel search window needs to be.

Changes to some search parameters are also needed on the AT side to support large cell radii. In order for the AT to find neighbouring sectors and correctly perform active and candidate set management, the neighbour search windows have to be increased. This is because with large cell radii, the differential delay between the serving sector and transmissions from candidate sectors can be quite large. Given the geometry of the network, it should be sufficient for the neighbour search windows to be expanded by a factor of 8, and this can be accomplished by reinterpreting the search window size field in the neighbour list message⁵.

Additional changes need to be made for increasing the data rate control (DRC) length. In the IMT-2000 CDMA multi-carrier 1xEV-DO system, the access terminal continuously sends its desired forward link data rate on the DRC to the base station. The DRC word can extend 1, 2, 4 or 8 reverse link slots. Right after the access terminal has finished sending a given DRC, it expects that the next forward link slot directed to it will be encoded according to its last DRC request.

⁵ Refer to <http://www.ic.gc.ca/eic/site/smt-gst.nsf/eng/sf09134.html>, § 9.7.6.2.5.

The reverse link timing of the DRC channel is advanced by one-half slot with respect to the forward link timing for the base station to allow the base station enough time to process the last DRC sent by each AT. This 1 024-chip budget is more than enough for regular terrestrial communications since the cell radii are of the order of a few km. However, for the airborne system, this is insufficient since the one-way propagation delay to the edge of a base station covering 250 kilometres is already around 1 024 chips. The solution lies in choosing a long DRC length and, at the base station side, decoding the DRC word before the whole length of it has been received.

3.3.3 Handoff

The IMT-2000 CDMA Multi-Carrier 1xEV-DO airborne system uses multiple transmit and receive antennas on the access terminal side. The system uses four antennas, two sets of cross-polarization pairs. The access terminal has two antenna ports and a switch matrix to control multiplexing of the four antenna inputs into the two antenna ports on the access terminal. To provide spatial diversity in demodulation of the serving sector, the system combines the two antenna inputs belonging to the best or strongest polarization. Occasionally, the access terminal needs to search other antenna ports for possible transmissions from other sectors. To do so without breaking the connection to the serving sector, the access terminal effectively switches to single antenna demodulation. At the same time, the antenna port connected to the antenna with weaker input is switched to other antenna inputs to search for pilot transmissions from sectors on the AT's neighbour list. When this brief search is done, the AT resumes dual antenna demodulation.

The purpose of the IMT-2000 CDMA multi-carrier 1xEV-DO airborne system handoff procedure is to ensure that the access terminal is communicating with the access network (AN) through the best or strongest serving sector while using its best polarization pair of antennas for forward link demodulation. At the same time, the access terminal should transmit on the reverse link using its best antenna in orientation and polarization. The complexities of the airborne handoff procedure arise from the fact that as the serving sector changes, so does the concept of best antennas on the forward and reverse links.

4 System for general aviation air-to-ground radiotelephone within the United States of America

4.1 General aviation air-to-ground radiotelephone service

This service operates in the 454-459 MHz band and can provide a variety of telecommunication services to private aircraft such as small single engine planes and corporate jets. CFR47⁶ § 22.805 contains the channel allocations for the general aviation air-to-ground service. These channels have a bandwidth of 20 kHz and are designated by their centre frequencies in megahertz.

TABLE 1

Signalling channel pair for general aviation air-ground systems

Ground	Airborne mobile
454.675	459.675

- a) Channel 454.675 MHz is assigned to each and every ground station, to be used only for automatically alerting airborne mobile stations of incoming calls.
- b) All airborne mobile channels are assigned for use by each and every airborne mobile station.

⁶ Refer to: <http://www.gpo.gov/fdsys/pkg/CFR-2010-title47-vol2/pdf/CFR-2010-title47-vol2-part22-subpartG-subjectgroup-id140.pdf>.

Communication channel pairs

Ground	Airborne mobile
454.700	459.700
454.725	459.725
454.750	459.750
454.775	459.775
454.800	459.800
454.825	459.825
454.850	459.850
454.875	459.875
454.900	459.900
454.925	459.925
454.950	459.950
454.975	459.975

The transmitting power of ground and airborne mobile transmitters operating in the general aviation air-ground radiotelephone service on the channels listed in CFR 47 § 22.805 must not exceed:

- a) Ground station transmitters: the effective radiated power of ground stations must not exceed 100 Watts and must not be less than 50 Watts, except as provided in CFR 47 § 2.811.
- b) Airborne mobile transmitters: the transmitter power output of airborne mobile transmitters must not exceed 25 Watts and must not be less than 4 Watts.

Annex 3**Systems for public communications with aircraft⁷ in some countries in Region 3****1 Introduction**

In some countries in Region 3, there are currently two systems aiming to provide broadband DA2GC. These are described in the sections below.

⁷ APT has developed a guideline on the maximum permitted power for cellular base stations onboard aircraft. See [APT/AWF/OP-02\(Rev.2\)](#): APT Guideline on “Technical conditions for the use of mobile phones on-board aircraft”.

2 Air-to-ground communication system in China

2.1 Introduction

To meet the growing demand of the current and future airborne broadband communication, China has made significant effort on planning, developing, and deploying the air-to-ground (ATG) communication systems with aircraft. The system is based on the SCDMA broadband wireless access standard in Recommendation ITU-R M.1801. The SCDMA ATG wireless broadband access system contains base stations and terminals. The base stations are deployed to cover the entire flight course and communicate with the airborne terminals to achieve broadband communication between the ground and airplanes. The prototype systems have been successfully tested in trial flights at the frequency range of 1.785-1.805 GHz. The system's ATG broadband communication capability has been successfully tested in China.

2.2 Operational features

The system operational features are as follows:

- Automatically connecting to the terrestrial broadband wireless network to provide air-to-ground communications.
- Supporting the voice, trunked voice and broadband data communication services such as providing backhaul of the on-board WiFi, cellular pico-cells, and on-board wireline voice calls and Internet access.
- Supporting the seamless communication roaming and handoff on the complete flight course.

2.3 System architecture

The basic system architecture is shown in Fig. 7.

The system functions are as follows:

- The system includes base stations (BTS) on the ground connected to PSTN, Internet and airborne terminals with interfaces to other on-board devices such as wireline hubs, WiFi routers, pico-cells, among others.
- The radio access layer provides the radio access functions between the BTS and airborne terminals. The radio access layer performs basic radio access functions such as random access, paging, voice communications, data communications and trunked voice functions.
- The core control layer provides the control functions, such as handoff, roaming, terminal and user authentication, voice call switching, and data routing. It is between the BTS and other core network equipment such as data switches and routers, soft switches, media gateways, AAA (Authentication, Authorization, and Accounting) servers, billing servers, and HLR (Home Location Register).
- This entire ATG communication network including all layers supports separation of different data flows and also provides adequate protection on the data.

FIGURE 7

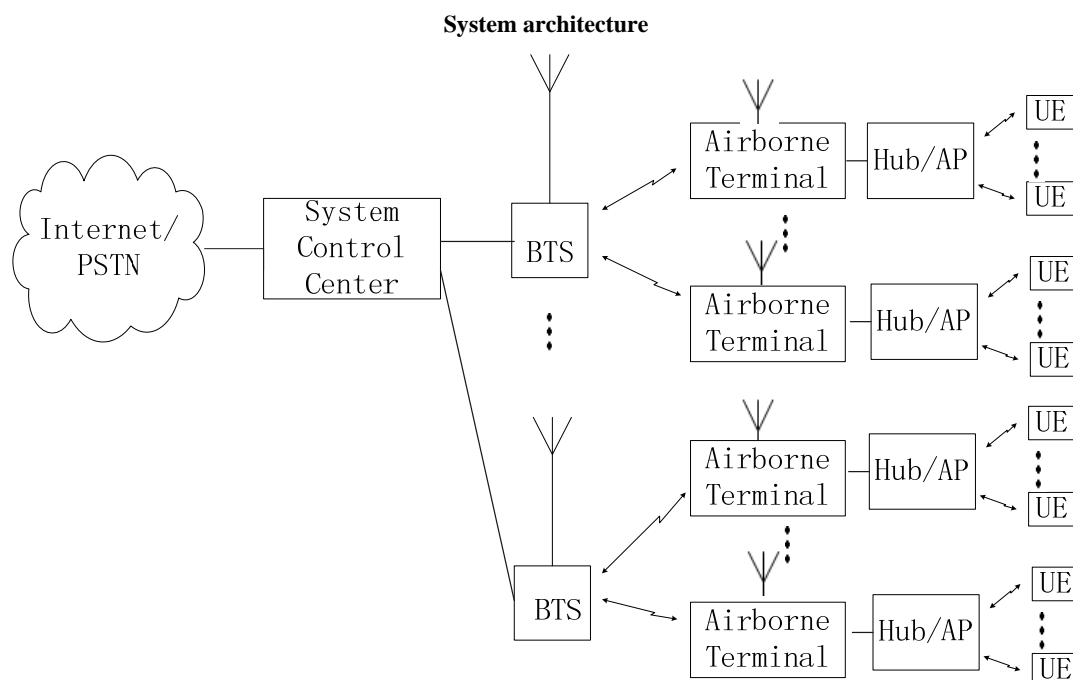

2.4 Channelization scenario

The SCDMA radio interface supports a channel bandwidth of a multiple of 1 MHz up to 5 MHz. Sub-channelization and code spread, specially defined inside each 1 MHz bandwidth, provides frequency diversity and interference observation capability for radio resource assignment with bandwidth granularity of 8 kbit/s. The channelization also allows coordinated dynamic channel allocations among cells to efficiently avoid mutual interference. The system employs TDD to separate uplink and downlink transmission.

3 Air-to-ground communication system in Japan

3.1 Background

Demand has increased for better mobile phone and wireless local area network (LAN) access for people on-board aircraft. Now, several airlines have started cabin use of cellular phones with a system involving satellites. Meanwhile, in Japan, the air-to-ground (ATG) communication system with aircraft, which achieves over 100 Mbit/s transmission speed, is also being studied. In the system, the 40 GHz band facilitates broadband wireless communications on airplanes and on the ground. As shown in Fig. 8, airplanes fly over ground tracking antennas arranged at regular intervals.

As the aircraft passes overhead, the antennas hand over service one after another to the aircraft. The 40 GHz band is not used heavily in commercial applications and is expected to facilitate the broadband communication system.

FIGURE 8
Over 40 GHz wave broadband wireless direct communication system
between air and ground operated in Japan

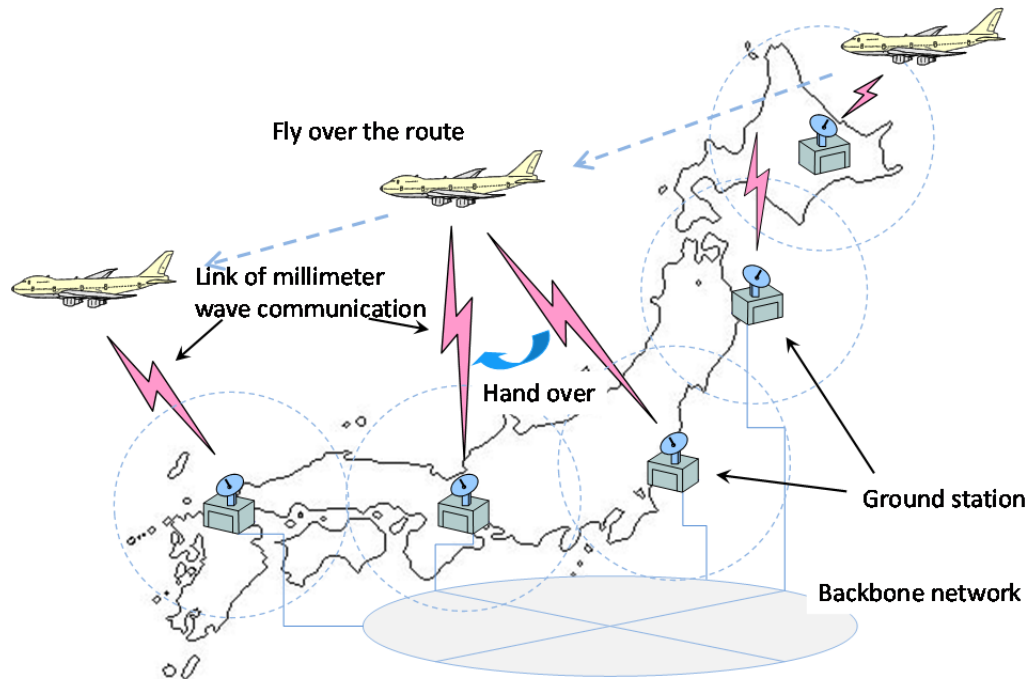

3.2 Descriptions of system architecture and communication equipment

The specifications of the proposed communication system and the airborne/ground equipment are described below. The frequency bands of the up and down links are supposed to use the 40 GHz frequency range and are tentatively given at 44 and 46 GHz bands, respectively for the prototype development. Table 2 summarizes the specification of the proposed communication system.

TABLE 2
Specifications of the communication system

Item	Specifications	Remark
Coverage area	10 km ~ 50 km in radius	Depend on weather conditions and communication speed.
Transmission rate	Up to 100 Mbit/s or over	Variable
Protocol	Full-duplex	
Frequency	Downlink: 44.45 GHz \pm 100 MHz Uplink: 46.8 GHz \pm 100 MHz	The frequencies are tentatively allocated.

The system uses the frequency division multiplex (FDM) method for communication.

Considering the characteristics of the millimetre wave and the spectrum efficiency, both the airborne and the ground antenna track each antenna position. Therefore, the antenna system needs to consider the characteristics of the millimetre wave and the geographical dimensions. For example, the ground-based tracking antenna must continuously track the aircraft with a high degree of accuracy. Meanwhile, the airborne antenna must track the ground-based antenna based on the aircraft attitude and position, and must be also compact and lightweight.

A) Ground station antenna

The ground station has a mechanically controlled reflector to direct the antenna beam in a specific direction by tilting the reflection disk mechanically as shown in Fig. 9. With a reflector controlling the antenna beam in the system, the mechanism provides a cost-effective, power-efficient tracking antenna. Furthermore, a radio wave was separately transmitted at 44.55 GHz, in addition to the communication signal wave so that the system could execute the mono-pulse tracking technique by monitoring the reception level of the radio wave signal.

FIGURE 9

Prototype of ground tracking antenna with lens antenna

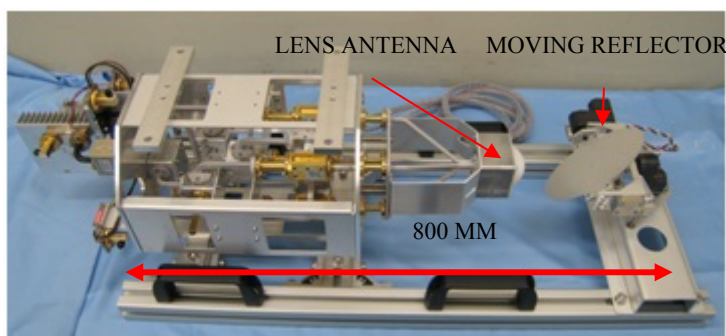

B) Airborne antenna

As shown in Fig. 10, the airborne antenna consists of a transmission (left) and a reception (right) components using active phased array antenna (APAA) technology, which is capable of two-dimensional electronic antenna scanning. The APAA is composed of 64 elements in an eight-by-eight array. The approximate weight of the antenna is 11 kilogrammes. Each element of the APAA is connected to the transmitting/receiving module to control the antenna beam direction by changing the phase component with 4-bit resolution. In addition, the directional control of the antenna is limited to ± 45 degrees as a device specification.

FIGURE 10

Appearance of transmission and reception components of active phased array antenna

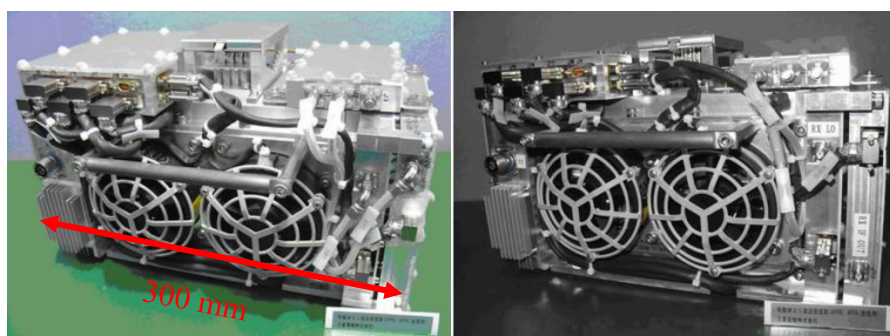

3.3 Verification tests and results

To verify the overall performance of this system, several trial flights with the prototype equipment were successfully conducted in 2012. This verification was mainly for the basic property of the airborne antenna, the ground tracking antenna, access control equipment and some other equipment.

An airplane with the APAA was used as the airborne station. Table 3 presents an overview of the airborne verification test, and Fig. 11 illustrates a diagram of the airborne verification test.

The transmission and reception frequencies were allocated as 46.8 GHz and 44.45 GHz, respectively, for simultaneous transmission. The data transfer rate was 141.7 Mbit/s when QPSK modulation with a symbol rate of 78 Msymbol/s was applied. The 106.3 Mbit/s transfer rate was realized when 8PSK modulation with a symbol rate of 39 Msymbol/s was applied.

The antenna control information, such as the reception level and antenna directional data, was stored in the control sections. The modem signal and the error information of Bit Error Rate (BER) or Packet Error Rate (PER) (circuit quality) were also stored in the modem sections at both the airborne and ground stations. The flight data, which consist of airplane position/attitude information, were stored only on the aircraft. The ground station treats the transmitting and receiving data through millimetre waves.

TABLE 3

Airborne verification test overview

Item	Contents
Airborne station	Active phased array antenna
Ground station	Millimetre-wave transmitter/receiver with mechanical driven antenna
Frequency	Uplink: 46.8 GHz Downlink: 44.45 GHz
Data transfer rate	141.7 Mbit/s at 78 Msymbol/s (QPSK) 106.3 Mbit/s at 39 Msymbol/s (8PSK)
Acquisition data	<ul style="list-style-type: none"> – Control information such as reception level and antenna directional data. – Modem signal, error information of packet error rate or bit error rate. – Flight data (airborne status such as position/attitude information).

FIGURE 11

Airborne verification test system

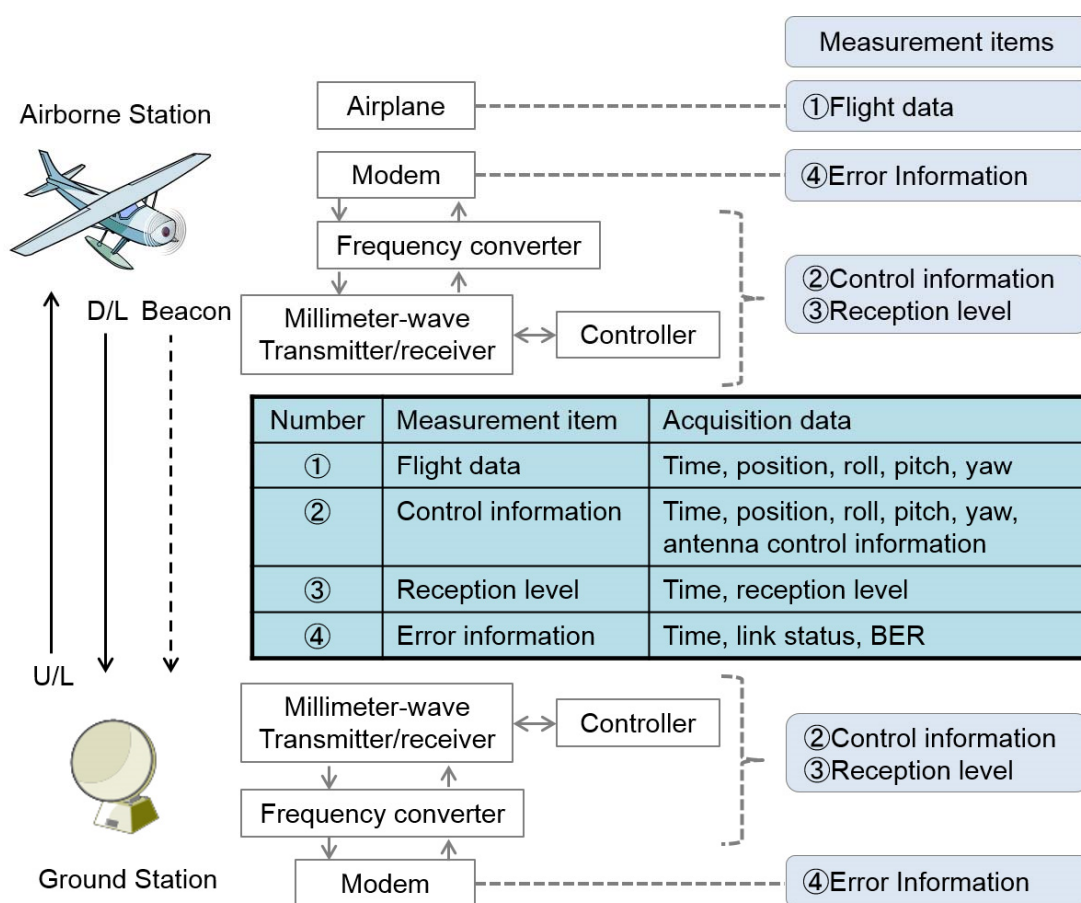

We evaluated the following items in the airborne verification test:

- a) antenna pattern measurement,
- b) tracking ability test,
- c) communication capability test and mass volume data transfer test, and
- d) communication distance test.

Finally, the results confirmed the success of the airborne verification tests as follows:

- a) The beam width of the antenna was observed at about 8 degrees in the airborne tests, while it was observed at 10 degrees in an anechoic chamber. Although the width becomes approximately 2 degrees narrower than that of the designed value, the characteristics of the antenna beam were almost identical.
- b) The system with tracking mode could track each antenna position correctly when the maximum angular ground speed was 229.65 km/h at an altitude of 785.47 m, which corresponds to 4.7 degrees per second in calculation.
- c) Reception level and BER characteristics were measured and confirmed when the modulation types were QPSK and 8PSK and the flight altitude was approximately 2 000 m.

- d) The results indicated that communication was established for a horizontal distance of 2 380 m and a flight altitude of 1 816 m, thus the communication distance was approximately 3 km. At this time, the angle of elevation sighting the airborne station from the ground station is 38 degrees, which was confirmed as a minor difference compared to the device specification of 45 degrees for the beam scan range of the APAA used on the airborne station.

Application of these results to various aircraft shall establish an environment that enables mass volume downloading with bidirectional IP communication.
