

International Telecommunication Union

ITU-R
Radiocommunication Sector of ITU

Report ITU-R M.2479-0
(09/2019)

**The use of land mobile systems, excluding
IMT, for machine-type communications**

M Series
**Mobile, radiodetermination, amateur
and related satellite services**



International
Telecommunication
Union

Foreword

The role of the Radiocommunication Sector is to ensure the rational, equitable, efficient and economical use of the radio-frequency spectrum by all radiocommunication services, including satellite services, and carry out studies without limit of frequency range on the basis of which Recommendations are adopted.

The regulatory and policy functions of the Radiocommunication Sector are performed by World and Regional Radiocommunication Conferences and Radiocommunication Assemblies supported by Study Groups.

Policy on Intellectual Property Right (IPR)

ITU-R policy on IPR is described in the Common Patent Policy for ITU-T/ITU-R/ISO/IEC referenced in Resolution ITU-R 1. Forms to be used for the submission of patent statements and licensing declarations by patent holders are available from <http://www.itu.int/ITU-R/go/patents/en> where the Guidelines for Implementation of the Common Patent Policy for ITU-T/ITU-R/ISO/IEC and the ITU-R patent information database can also be found.

Series of ITU-R Reports

(Also available online at <http://www.itu.int/publ/R-REP/en>)

Series	Title
BO	Satellite delivery
BR	Recording for production, archival and play-out; film for television
BS	Broadcasting service (sound)
BT	Broadcasting service (television)
F	Fixed service
M	Mobile, radiodetermination, amateur and related satellite services
P	Radiowave propagation
RA	Radio astronomy
RS	Remote sensing systems
S	Fixed-satellite service
SA	Space applications and meteorology
SF	Frequency sharing and coordination between fixed-satellite and fixed service systems
SM	Spectrum management

Note: This ITU-R Report was approved in English by the Study Group under the procedure detailed in Resolution ITU-R 1.

Electronic Publication
Geneva, 2019

© ITU 2019

All rights reserved. No part of this publication may be reproduced, by any means whatsoever, without written permission of ITU.

REPORT ITU-R M.2479-0

The use of land mobile systems, excluding IMT, for machine-type communications

(2019)

1 Introduction

Machine-type communications (MTC) utilize wired and wireless communication networks. The advantages of wireless technologies include reduced complexity in cabling, cable protection and plugs, increased mobility and flexibility as well as access to a “wear and tear” free transmission medium. MTC includes wireless industrial automation (WIA) applications such as factory automation, process automation, audio visual interaction, remote control, mobile robotics and vehicles ranging from low latency applications to reliable and secure applications as described in Annex 1. MTC also includes smart grid applications such as millisecond-level precise load control, distribution automation, electricity information acquisition, electric vehicle charging stations and distributed generation monitoring. These encompass low latency and high reliability applications as well as massive connection type applications as described in Annex 2.

The use of the terrestrial component of International Mobile Telecommunications for narrowband and broadband machine-type communications are covered in Report ITU-R M.2440.

2 Objectives of this Report

This Report provides information on the use of land mobile systems, excluding IMT, for MTC.

The Report presents information on wireless industrial automation (WIA). Various typical WIA applications include factory automation, process automation, audio visual interaction, remote control, mobile robotics and vehicles, ranging from low latency applications (e.g. robotic arms) to reliable and secure applications (e.g. driverless autonomous transportation systems).

This Report also presents information of the applications of MTC in Smart Grid, such as millisecond-level precise load control, distribution automation, electricity information acquisition, distributed generation monitoring, electric vehicle charging stations.

This Report also provides examples of frequency bands used for IoT/M2M applications.

3 Related documents**3.1 ITU documents**

Resolution ITU-R 66 – Studies related to wireless systems and applications for the development of the Internet of Things

Recommendation ITU-R SM.1132 – General principles and methods for sharing between radiocommunication services or between radio stations

Recommendation ITU-R M.1450 – Characteristics of broadband radio local area networks

Recommendation ITU-R SM.1896 – Frequency ranges for harmonization of short range devices

Recommendation ITU-R M.2002 – Objectives, characteristics and functional requirements of wide-area sensor and/or actuator network (WASN) systems

Report ITU-R M.2440 – The use of the terrestrial component of International Mobile Telecommunication (IMT) for Narrowband and Broadband Machine-Type Communication

Report ITU-R SM.2152 – Definitions of Software Defined Radio (SDR) and Cognitive Radio System (CRS)

Report ITU-R SM.2153 – Technical and operating parameters and spectrum requirements for short-range devices

Report ITU-R SM.2255 – Technical characteristics, standards and frequency bands of operation for radio-frequency identification (RFID) and potential harmonization opportunities

Report ITU-R SM.2351 – Smart grid utility management systems

3.2 Other references

NOTE – The references outside the ITU can be obtained as described in Annex 4.

- [1] [ETSI TR 102 889-2 V1.1.1](#) (2011-08): Electromagnetic compatibility and Radio spectrum Matters (ERM); System Reference Document; Short Range Devices (SRD); Part 2: Technical characteristics for SRD equipment for wireless industrial applications using technologies different from Ultra-Wide Band (UWB).
- [2] ECC Report 206: Compatibility studies in the band 5 725-5 875 MHz between SRD equipment for wireless industrial applications and other systems.
- [3] ERC Recommendation 70-03: Relating to the use of Short Range Devices (SRD).
- [4] ECC Recommendation (02)05: "Unwanted emissions".
- [5] EN/IEC 61784-2:2010: "Industrial communication networks – Profiles – Part 2: Additional fieldbus profiles for real-time networks based on ISO/IEC 8802-3".
- [6] EN/IEC 62591: "Industrial communication networks – Wireless communication network and communication profiles –WirelessHART®".
- [7] IEC 62657-2: "Industrial communication networks – Wireless communication networks – Part 2: Coexistence management".
- [8] IEEE 802.11-2016: "IEEE Standard for Information technology – Telecommunications and information exchange between systems – Local and metropolitan area networks – Specific requirements – Part 11: Wireless LAN Medium Access, Control (MAC) and Physical Layer, (PHY) Specifications".
- [9] IEEE 802.15.1-2005: "IEEE Standard for Information technology – Telecommunications and information exchange between systems – Local and metropolitan area networks – Specific requirements – Part 15.1: Wireless medium access control (MAC) and physical layer (PHY) specifications for wireless personal area networks (WPANs)".
- [10] IEEE 802.15.4: "IEEE Standard for Information technology – Telecommunications and information exchange between systems – Local and metropolitan area networks – Specific requirements Part 15.4: Wireless Medium Access Control (MAC) and Physical Layer (PHY) Specifications for Low-Rate Wireless Personal Area Networks (WPANs)".
- [11] ETSI EN 300 440: "Short Range Devices (SRD); Radio equipment to be used in the 1 GHz to 40 GHz frequency range; Harmonised Standard for access to radio spectrum".
- [12] ETSI EN 303 258: "Wireless Industrial Applications (WIA); Equipment operating in the 5 725 MHz to 5 875 MHz frequency range with power levels ranging up to 400 mW; Harmonised Standard for access to radio spectrum".
- [13] MulteFire release 1.1 specifications.

4 Abbreviations

3GPP	Third Generation Partnership Project
6LoWPAN	IPv6 over Low power Wireless Personal Area Network
CEPT	Conference of Postal and Telecommunications Administrations
eMTC-U	eMTC over unlicensed
IoT	Internet of Things
IoT-G	Internet of Things-Grid
LTE	Long Term Evolution
MBB	Mobile BroadBand
M2M	Machine-to-Machine
MTC	Machine Type Communications
MF	MulteFire
NB-IoT-U	NarrowBand-IoT over unlicensed
OFDM	Orthogonal Frequency Division Multiplexing
PLMN	Public Land Mobile Network
PPWN	Private Power Wireless Network
SC-FDM	Single-carrier Frequency-Division Multiplexing
SWIN	Smart and Wide-Coverage Industry-Oriented Wireless Network
WIA	Wireless Industrial Automation

5 Overview of existing and possible future IoT/M2M applications

5.1 Typical Wireless industrial automation (WIA) applications

Modern automation technology applications are increasingly using wireless technologies to transfer data. But, industrial automation applications require robust technologies to be used for their critical wireless communication. The advantages of wireless technologies are savings of often complex and expensive cables, cable protection and plugs, the increased mobility and flexibility as well as the wear and tear free transmission medium.

The majority of wireless systems for industrial automation applications use the bands designated for Industrial, Scientific and Medical applications (ISM) and Short Range Devices (SRDs). The main incentive for using some of these bands is their broad harmonization and their license-exempt status.

Details of the current use, technology and related deployments can be found in Annex 1.

5.2 Wireless Smart Grid Applications

Wireless communication technologies can be rapidly deployed to meet a variety of smart grid applications such as smart office, distribution automation¹ etc. At present, there are many non-IMT wireless technologies used in smart grid. The current status of smart grid, wireless technologies, frequency bands and deployment can be found in Report ITU-R SM.2351.

¹ Distribution automation is the process by which monitoring and control of intelligent electronic devices deployed in the utility distribution system is automated.

Smart grid applications rely on communication network for information exchange to ensure the safety and stable operation of the power system. It utilizes both wired and wireless communication networks where the advantages of wireless technologies include flexibility for deployment. Both public and private wireless communication infrastructures are used in this context.

6 Technical and operational aspects of MTC for WIA to support narrowband and broadband machine-type communication

WIA applications utilize robust wireless technologies for wireless links in industrial applications. For example, a factory may use a high density of terminals and access points and multiple technologies. More and more communication technologies are being considered for these WIA applications, such as context information sensing, transmission efficiency and security technology.

7 Information on the spectrum usage of MTC applications

In recent years, additional varieties of new wireless applications for MTC have continued to emerge. Users of particular applications select a suitable technology based upon a number of important metrics such as reliability, simplicity, efficiency, range of transmission and cost. Massive applications of wireless intelligent terminals can facilitate the integration of real physical world and virtual network world, and achieve interconnection between resources, information, and goods.

Table 1 illustrates examples of frequency bands that are used in various parts of the world for MTC.

TABLE 1
Examples of frequency bands that are used for MTC

Europe	5 725–5 875 MHz band is used by a number of MTC technologies for WIA
Region 2	5 725–5 850 MHz band is used by applications e.g. MTC for WIA
China	223-235 MHz band is used by smart grid. 5 725–5 850 MHz band is used by applications e.g. MTC for WIA.

8 Enabling and existing technologies

8.1 WIA applications standards

An important technology for WIA devices is IEEE 802.11, especially devices according to the amendments IEEE 802.11n, ac and ax. Devices based on this technology offer sufficient bandwidth for various applications. For these applications, systems typically use a nominal channel bandwidth of 20 MHz, which allows to operate multiple systems in parallel and independently.

MulteFire (MF) is an interoperability specification that provide certification based upon a subset of 3GPP LTE technology and is a potential enabler for WIA applications. The MF Release 1.0 specification was completed in January 2017 [13] and the MF Release 1.1 specification was completed by December 2018. In MulteFire 1.1, which includes MF eMTC-U and MF NB-IoT-U features supporting a wide range of applications from mobile broadband to machine type communications. The MBB feature of MulteFire provides a nominal channel bandwidth of 20 MHz. MF eMTC-U supports a nominal channel bandwidth of 1.4 MHz. MF NB-IoT-U has a nominal channel bandwidth 180 kHz. Both MF eMTC-U and MF NB-IoT-U target enhanced coverage while also reducing device complexity. This makes MF eMTC-U and MF NB-IoT-U suitable for applications such as process automation or other applications of factory automation.

In addition, devices and systems using other technologies beyond those given in this report are in use, such as visual monitoring and video surveillance. Systems are often based on proprietary technology, but operate in accordance with the applicable standard. According to the nature of video transmission and high bandwidth requirements these broadband systems operate using several MHz of spectrum.

8.2 Wireless Smart Grid applications

A variety of non-IMT wireless technologies are used in smart grid applications. At present, most of the smart grid applications use unlicensed frequency. However, due to the need for reliability and security, licensed frequency and private wireless network are often used in smart grid.

In China, both SWIN system (230 MHz discrete multi-carrier power wireless communication system) and IoT-G 230 system (230 MHz discrete multi-carrier electric wireless communication system), are the options for wireless smart grid applications, and have been used to achieve broadband transmission by aggregating multiple 25 kHz discrete narrowband carriers at 223-235 MHz range (also referred here as 230 MHz band) to provide wireless service for smart grid.

8.2.1 SWIN system

SWIN adopts 25 ms radio frame, 2 kHz subcarrier spacing, and uses OFDM for downlink and SC-FDM for uplink. It supports capabilities such as discrete carrier aggregation, spectrum sensing, coverage enhancement, broadband and narrowband combining, end-to-end service isolation and software radio.

– Discrete carrier aggregation

In order to improve the spectrum efficiency, SWIN system adopts discrete narrowband aggregation technology, which transforms some narrowbands of 230 MHz frequency band into logical broadband frequency resources, to improve transmission rate and system capacity.

– Spectrum sensing

In SWIN system, spectrum sensing is used to detect other wireless signals. The other radio systems transmission signal is detected in time to avoid interference from them, so that SWIN system can coexists with other radio systems using the same frequency band. Benefit from the efficient utilization of frequency, system capacity of SWIN system is increased by using dynamic spectrum sharing.

– Coverage enhancement

To achieve coverage enhancement for smart grid applications, SWIN use repeating transmission of data and control signals. Due to the good propagation property of the 230 MHz frequency band and the coverage enhancement technology, SWIN can provide wide area coverage. In addition, multiple subframe scheduling is used to reduce control signalling overhead to further improve the network capacity.

– Broadband and narrowband combining

Various transmission band terminals from 25 kHz to 5 MHz can be supported in SWIN system. Low cost narrow band terminal can be used for low rate service. Broadband terminal can be used for high rate and low latency smart grid service. So SWIN system can satisfy various smart grid wireless services.

– End-to-end service isolation

To guarantee smart grid safety and security, SWIN supports end-to-end services isolation for services in I/II production area and services in III/IV management areas. In SWIN, each class application can be represented by a unique *ueServiceType*. The overall radio resource can be divided into several resource pools, while each resource pool is assigned for one class service. A terminal selects the

corresponding resource pool according to the pre-stored *ueServiceType*. In this way, SWIN ensures that the communication services in the production area of the smart grid are completely isolated from those in management area, and sufficient radio resource can be reserved for some important delay-sensitive applications.

– **Software defined radio**

Different portions of the 230 MHz frequency band are available for smart grid in different regions in China. Software defined radio (SDR) is used in SWIN system to access the different portions. With SDR, all kinds of frequency distributions can be configured. The system can easily adapt for extended business or deploying in different radio environments by software upgrades. Consequently, the previous investments are protected and overall maintenance costs are reduced by SDR.

SWIN system has the following capabilities: wide coverage area, high capacity, high spectrum efficiency, spectrum adaptability, security, reliability and flexibility. It has been tested in Haiyan of Zhejiang, Jinjiang of Fujian, and Wulong of Chongqing 3 cities in China for large-scale trial. Smart grid applications supported by SWIN system include distribution automation, electricity information acquisition, distributed generation, electric vehicle charging stations, transmission line monitoring and millisecond-level precise load control were successfully tested.

8.2.2 IoT-G 230 system

IoT-G 230 uses OFDM for downlink and SC-FDM for uplink. IoT-G 230 also uses 10 ms radio frame length and 3.75 kHz subcarrier spacing. To satisfy the requirements of smart grid applications, IoT-G 230 supports capabilities including discrete carrier aggregation, multiple-antenna transmission and reception, end-to-end service isolation, grant-free transmission and frequency hopping.

– **Discrete carrier aggregation**

IoT-G 230 supports broadband transmission by aggregating multiple 25 kHz narrowband carrier for each transmission. Each coded data block is equally divided into multiple sub-blocks, which are then transmitted on multiple 25 kHz carriers in parallel with each sub-block on one carrier to improve data rate and system capacity.

– **Multiple-antenna transmission and reception**

Electricity information acquisition service has deep coverage requirement as many terminals (e.g. electric meters) are deployed in complex propagation environment such as building corridors and basement, where signals are prone to blockage and channel fading. IoT-G 230 introduces multiple-antenna technology, supporting transmission and reception on two antenna ports at base stations to obtain space diversity gain and power combining gain.

To further enhance coverage, IoT-G 230 adopts some fundamental designs in NB-IoT such as repeating transmission of data and control signals. The multiple-antenna technology, coverage enhancement techniques, and the good propagation property of the 230 MHz spectrum, enable IoT-G 230 to provide wide area coverage required for many smart grid applications.

– **End-to-end service isolation**

To guarantee power grid safety and security, IoT-G 230 supports end-to-end services isolation for services in I/II production area and services in III/IV management areas.

For the air interface, IoT-G 230 achieves radio resource isolation by configuring uniquely different Public Land Mobile Network (PLMN) identities for different service classes. Each PLMN identity has its unique radio resource pool and that the base station determines the resource pool for a terminal according to the pre-stored PLMN information stored in the SIM card.

For base station and core network, IoT-G 230 uses hardware isolation for base station and core network by equipping two sets of physically separated network entities for services in I/II production area and services in III/IV management areas.

This ensures that the communication services in the production area of the smart grid are completely isolated from those in management area, and sufficient radio resource can be reserved for some important delay-sensitive applications.

– **Frequency hopping**

IoT-G 230 supports inter-carrier frequency hopping across the whole 230 MHz band and in the granularity of 10 ms. In the event that a transmission suffers from severe fading or interference on a 25 kHz carrier, the system can quickly jump to another carrier which is not likely to undergo these negative effects, thereby improving communication reliability and robustness.

In summary, IoT-G 230 provides a high data rate, low-latency, high robustness, enhanced coverage, and high capacity solution for wireless smart grid network. IoT-G 230 reuses the classical design and key parameters of 3GPP network as much as possible, so that the corresponding base station and terminal equipment can be developed based on the existing hardware and software platform for 3GPP network, which helps lowering the cost of the whole network. The technical features of IoT-G 230 provides the fundamental building blocks to enable typical smart grid applications for private power wireless network such as millisecond-level precise load control. IoT-G 230 has been field tested in Suzhou, Jiangsu Province in China and is planned for large-scale deployment in 2019.

9 Deployment scenarios and architectures

9.1 Wireless industrial automation (WIA) applications

Typical industrial sites are manufacturers of goods or providers at any place within the delivery chain towards these goods (e.g. oil/gas/energy producers, suppliers of parts or components of these goods up to final assembly of the goods, after- production processes such as water/waste management).

Industrial automation requires "robust" wireless technologies to be used for their wireless links in industrial applications. More and more wireless solutions are being considered nowadays for these applications.

In a large industrial plant there is a considerable amount of different wireless systems and technologies for different purposes in parallel to each other (partly or completely overlapping). Such systems are subdivided into three main classes according to specific characteristics (e.g. indoor/outdoor, service area, number of devices, number of parallel networks).

Details of deployment scenarios and architectures for wireless industrial automation (WIA) can be found in Annex 1, section 4 and Annex 3, section 3.

9.2 Smart grid applications

Smart grid comprises the technologies applied to electrical grids (generation, transmission, distribution and consumption) with the purpose of improving decision making, data generation and managing information based on the increased level of automation and communication. It utilizes both wired and wireless communication networks where the advantages of wireless technologies include flexibility for deployment.

Details of deployment scenarios for private power wireless network in China can be found in Annex 2, section 6.

Annex 1

Wireless industrial automation applications

1 Introduction

This Annex provides information on wireless industrial automation (WIA) application. This includes information on how current radio systems for WIA, their evolution, and/or potentially new radio interface technologies and system approaches could be appropriate, taking into account the impact of the propagation characteristics related to the possible future operation of wireless industrial applications.

Wireless industrial automation applications would require appropriate consideration of the following demands:

- very low latency and high reliability machine-centric communication;
- high user density;
- maintaining high quality (e.g. robustness and low-latency real-time behaviour) at high mobility.

Furthermore the Report ITU-R M.2370-0 describes that machine to machine communication (M2M) is a growing market in future. For that reason it is necessary to consider the technical feasibility of current and future radio interfaces for WIA application within the framework of advanced manufacturing and Industry 4.0 (see Annex 4).

There has been recent academic and industry research and development related to suitability of WIA applications. For that reason the ETSI TR 102889-2 was developed to describe the requirements of WIA applications. Based on the ETSI TR 102889-2, some countries in Region 1 utilizes the frequency range from 5 725 MHz to 5 875 MHz for wireless industrial automation application allowing an output power up to 400 mW, given the implementation of appropriate spectrum access and mitigation techniques (see ETSI EN 303 258). The results of compatibility studies within the frequency range can be found in ECC Report 206.

2 Typical WIA Applications

2.1 Overview

2.1.1 Factory automation

Factory automation is used as synonym for discrete manufacturing where products are produced, assembled, tested or packed in many discrete steps (automotive, general consumer electronic, goods production). In the factories of the future, static sequential production systems will increasingly be replaced by novel, modular production systems offering high production flexibility and versatility. The concept of modular production systems encompasses a large number of increasingly mobile production assets. For these autonomous mobile assets, powerful wireless communication and localization services are required. For factory automation, in-time deliveries of messages and high reliability (robustness) are very important to avoid interruptions in the manufacturing process which leads to production loss. Redundancy, cyber security and functional safety are also very important for factory automation. Typically, every manufacturing step involves many sensors and actuators controlled by a single controller (e.g. Programmable Logical Controller). Many of these use wired connections which are often stressed by repeated movements and/or rotations and other harsh conditions.

FIGURE 1

Automation hierarchy in a discrete manufacturing factory plant with example technologies used

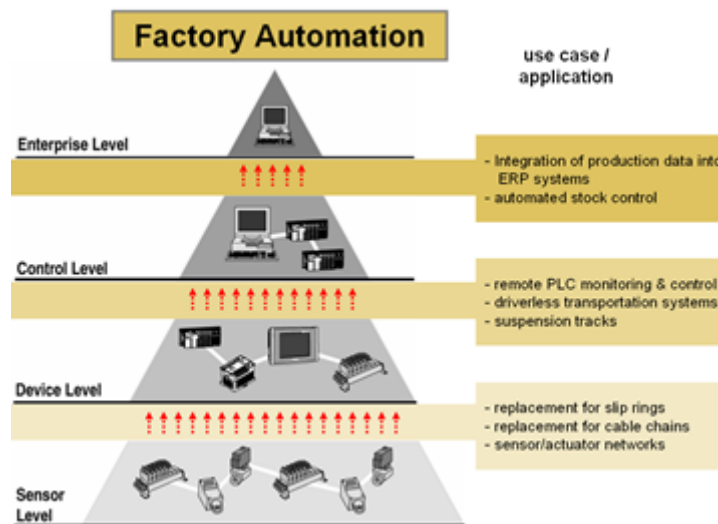

Today more and more devices, especially sensor and actuator nodes with relaxed requirements, are connected using wireless technology to improve productivity and increase availability compared to wired sensors/actuators at difficult locations.

Motion control is characterized by high requirements on the communications system regarding latency, reliability, and availability.

Application examples

- Automatic guided vehicles (AGV);
- Monorail systems;
- Conveyer belts;
- Single and collaborating mobile robots;
- High-bay storage/Intra logistics;
- Portal crane;
- Communication to rotating or moving machine parts;
- Assistance systems for workers and operators:
 - Video cam & display (e.g. Hololense);
 - Mobile control panels.

2.1.2 Process Automation

Process automation is defined as an automation application for industrial automation processes. It is typically associated with continuous operation, with specific requirements for determinism, reliability, redundancy, cyber security, and functional safety. Process Automation is typically used for continuous production processes to produce or process large quantities or batches of a certain product (like fluids, chemical, or an 'endless' product like e.g. wires, cables).

FIGURE 2

Automation hierarchy in a process plant with example technologies used

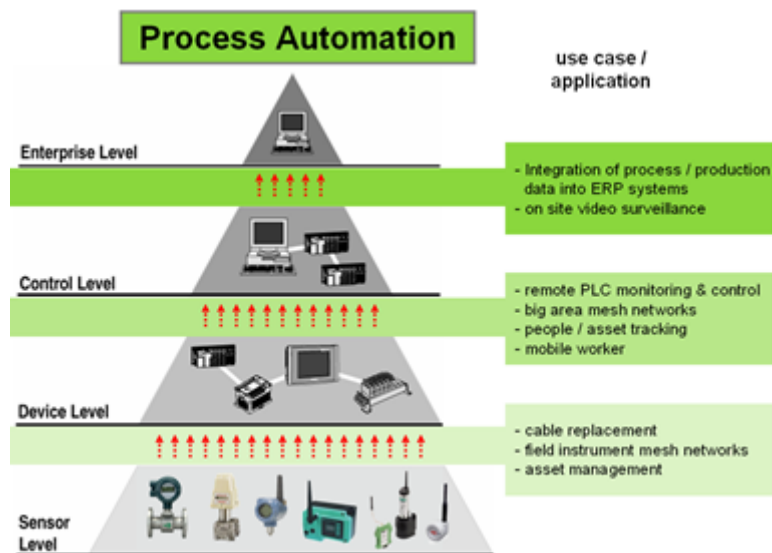

Process applications also require deterministic behaviour and typically use low latencies in the range between 100 ms and a few seconds. Process automation can cover relatively large areas and so wide wireless transmissions ranges are required. The end nodes (sensors) in process automation applications potentially have to have a battery life of several years.

On the sensor level you can find mesh networks for field instruments, based on different wireless mesh protocols. The mesh structure helps to achieve a large range coverage with standard low power levels and to be robust. On higher levels of the automation hierarchy e.g. at the control or enterprise level, where the data volume rises (e.g. portable supervisory stations), so throughput, security and availability becomes more important, but real-time communication requirements decrease.

Process automation covers, for example, the following industries: oil and gas, refining, chemical, pharmaceutical, mining, pulp and paper, water and wastewater and steel.

Application examples

- Portable supervisory station (commissioning, maintenance);
- Process sensors;
- Environmental sensors;
- Access to (high-level) information of field devices not transmitted over the 4 – 20 mA current loop.

2.1.3 Audio-visual interaction

Audio-visual interaction is characterized by a human being interacting with the environment or people, or controlling a device, and relying on audio-visual feedback.

2.1.4 Remote control

Remote control is characterized by a device being operated remotely, either by a human or a computer.

2.1.5 Mobile Robotics and Vehicles

Mobile robots and vehicles are playing an increasingly important role in modern factories. This includes mobile units for taking care of the supply of items and material on the shop floor level, such as autonomous guided vehicles (AGVs) or intelligent fork lifters, but also mobile manipulators, which

may be flexibly used at different locations and possibly even facilitate a close human-machine collaboration. In general, the performance and efficiency of such mobile units can be significantly increased if they are interconnected with each other as well as the environment using a powerful wireless system. For example, relatively simple and thus inexpensive AGVs may form a larger swarm by coordinating their actions based on information exchanged between them and thus jointly realize complex tasks, such as lifting items that would be too heavy or big for one unit alone. The more reliable and the faster the connectivity is, the safer and faster the coordination can take place. If the wireless system could additionally provide a sufficiently accurate information about the current location of a mobile unit (typical range of 10-50 cm), this could be beneficially exploited in many cases, for example for autonomous navigation or collision prevention.

2.2 Current applications

The following applications are examples for industrial wireless application in general requiring extreme low latency. One of the most important reasons for wireless usage in the industry is the control of moving parts. The traditional solutions are slip rings, or cable chains.

2.2.1 Robotic arms

FIGURE 3
Robotic arms

Data transfer from a moving robotic arm to a control panel has traditionally been a difficult task. A wireless system retrofit installation is the simple solution to many cable-related problems in manufacturing.

Industrial wireless systems must be adapt as requirements and capabilities increase. Constant maintenance and costly shut-downs caused by broken cables are currently being eliminated and replaced with more effective communication solutions.

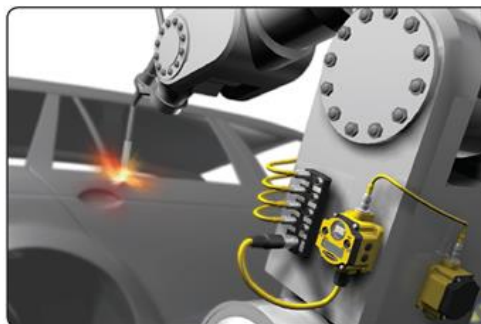

FIGURE 4

Cable replacement at the welding robot**Regular failures of trailing cables**

- Regular failures (every two to three months)
- Specified banding radii for trailing cables cannot be kept
- Signal transmission to the robot gripper is wired in parallel

Challenge

- Existing WLAN infrastructure should not be impaired
- IT requirement = low transmission power = up to 4 dBm
- Harsh environment conditions in the welding cell

Advantages of using wireless technologies

- Fast and low-cost integration into the existing configuration
- No downtimes during production
- No unplanned maintenance intervals anymore
- Robust wireless technology
- IT requirements met with modules having reduced transmission power

**2.2.2 Rotating tables/storages**

FIGURE 5

Rotating tables/storages

To provide continuous sensing of a manufacturing process on a rotation table, without the costly and cumbersome slip-rings required for normally hardwired sensing devices.

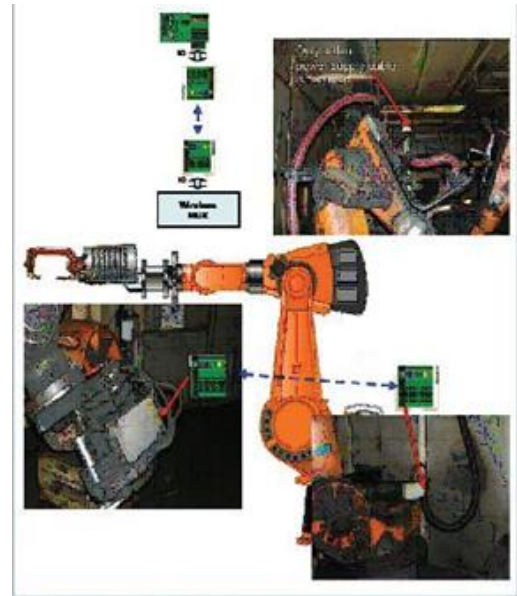
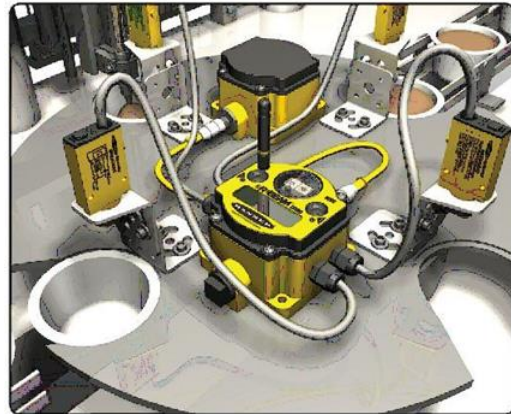

FIGURE 6

Wireless control of rotary storage

High costs due to slip ring transmitters

- Use of noise-prone slip rings
- 6 body rotary storage systems are located in one hall
- Connection to Profibus and the higher-level 97-400 PLC

Challenge

- 2 initiators for each storage location and correct positioning of the body
- 18 storage locations on 3 levels with 6 places for bodies each
- 9 further initiators and limit switches for position detection
- Existing WLAN Infrastructure should not be impaired

Advantages of using wireless technologies

- Fast and low-cost integration into the existing configuration instead of the slip ring
- No downtime during production
- Robust and reliable transmission method
- Fast replacement of I/O modules without complicated configuration (just reposition of ID plug)

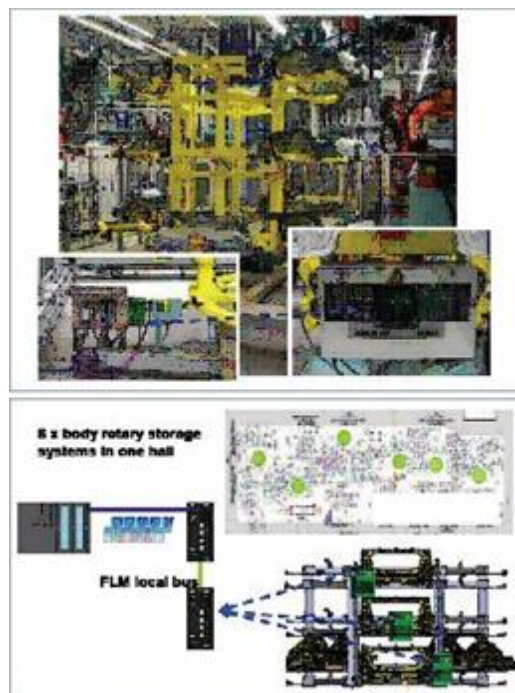

2.2.3 Overhead conveyer systems

FIGURE 7

Overhead conveyer systems

Track the presence/absence of an automobile door on an overhead conveyer, without available DC power.

This sensing system is able to withstand conditions in an industrial environment and will function where other wireless technologies are deployed.



The wireless nodes on an automotive conveyer communicate with a Gateway located off the chain-driven assembly line.

2.2.4 Other moving parts and applications

FIGURE 8

Moving parts and applications

Measuring data transfer from the hub to pod

- Recording the bending over strain gauges in the rotor blades
- Measuring device collects the measured values from the rotor blades
- Data is transmitted non-time-critical from the hub to the pod

Challenge

- The rotor hub is made of massive steel
- The massive gear block of the generator is located in the pod
- GFK sheath around the rotor and pod
- No objects may be installed outside

Wireless solution

- Circular polarized antennas for an optimized wireless signal
- Three antennas are located in the rotor blades to be independent of the blade orientation

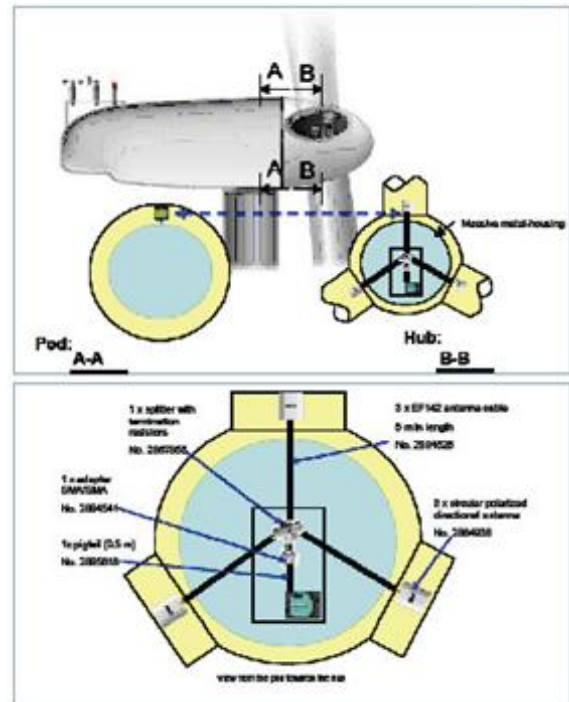

2.2.5 Driverless autonomous transportation systems

FIGURE 9

Driverless autonomous transportation systems

The use of AGV (automated guided vehicle) as autonomous transportation vehicles inside a warehouse or factory can facilitate the transfer of manufactures items or other goods like heavy pallets from the factory workstations to the loading dock. In this application the AGVs are moving autonomously through a manufacturing site without interrupting the assembly process. In order to ensure independent and autonomous operation of the vehicles a reliable and secure wireless communication system between the AGVs and a user or a control infrastructure is required (e.g. for sending and receiving the control commands). For this application reliability is crucial, since any longer interruption on the communication network might cause the stop of an AGV which could lead to disruptions in the assembly process.

An example for a currently used wireless communication system for the AGV application is industrial wireless LAN (IEEE 802.11).



The Gateway and Nodes communicate in a shipping warehouse.

2.2.6 Driverless autonomous transportation systems

The transportation vehicle inside a high rack warehouse needs to get a lot of information from the ERP system. In this application an industrial wireless solution exchanges the data between the moving vehicle and the stationary network.

FIGURE 10
High rack warehouse

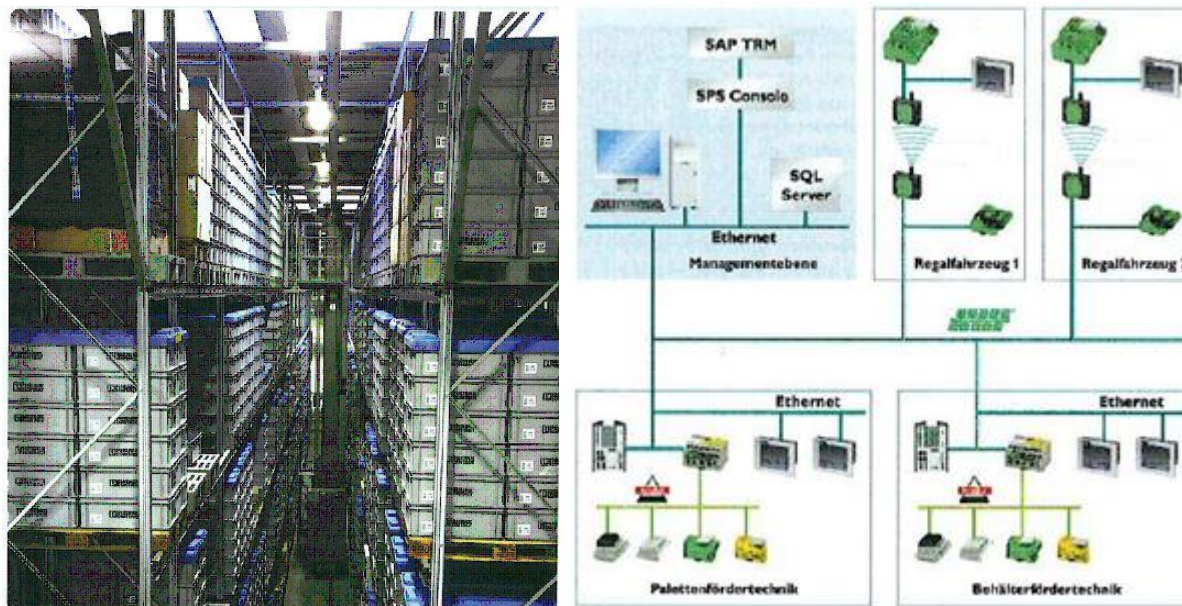

2.2.7 Crane control

FIGURE 11
Crane control

Locally limited access

- Connection crane – mobiles maintenance terminal
- Clear, location-dependent
- Service technician has full access to the PLC on site – no need to access the crane

Automatic connection setup

- Automatic connection with crane control when reaching the receiving area

Noise resistant

- Coexistence of wireless standards



2.2.8 Clean rooms

Liquid level measurements must be gathered in an industry-certified clean room. Retro-fit construction and cabling requires re-certification resulting in significant down time.

The fill levels of components for gel cap manufacturing need to be carefully monitored and logged during production to fulfil FDA requirements.

In addition, the measurements recorded need to coincide with the number of batches produced at the end of each process.

FIGURE 12

Clean rooms



During a gel cap production, the wireless nodes installed near each tank communicate readings from the Fill-Level sensors to the Gateway via RF link.

2.2.9 Refinery and gas production

FIGURE 13

Refinery industry

Application

Natural gas is needed by users in different amounts at different times. The suppliers need to be able to meet seasonal, weekly and hourly requirement fluctuations. Because the supply of natural gas from imported sources is not particularly flexible, it needs to be stored. Natural gas deposits are the best solution for managing the variation between winter and summer demands. Underground storage in cavities hollowed out of the salt domes hold smaller quantities of natural gas, which can be used compensate for short term demand fluctuations. The natural gas storage facility at Lesum near Bremen is one such underground cavern and along with the facility at Harsefeld bei Stade it is used to supply the consumers around Hamburg, Bremen, Bremerhaven and Cuxhaven on cold winter days.

The monitoring and control of all the operating procedures in the systems is fully automated by a process control system. The system is automatically switched off and made safe if values go above or below specified limit values. Three artesian wells have been installed to monitor the tightness of the underground storage facility. Their pressure values indicate any leaks in the system. If the pressure exceeds a particular limit, this will indicate a leak.



FIGURE 14
Gas production

Application

The development of oil fields in the Emsland region of Germany contributes significantly to raw material and energy supply in Germany. The increasing water cut of the oil fields is a problem for oil production west of Ems – the water content is now around 94 percent. Following separation, this deposit water is transported to the injection pumps. Mixed with fresh water, it is then injected through six water injection wells on the edge of the oil field back into the reservoir rock.

As an important process parameter, the injection pressure at the wells must be monitored continuously. Before converting to wireless technology, the measuring stations for acquiring measured values at the wells were inspected once a day. Now the injection pressure is continuously transmitted via an industrial wireless solution – even when disconnected from the mains. The result is increased safety and efficiency.



In order to transmit the measured values from a well situated on the northern edge of the field to the central injection pump 600 m away, a railroad line had to be crossed.



Before the crude oil is transported to the nearby Holthausen refinery or to the Brögbern pumping station, it must be processed.

3 Characteristics for WIA applications

3.1 Operation and maintenance characteristics

3.1.1 Ease of use

Communication networks should be able to be planned, set up, operated, and maintained without in-depth knowledge of communication technologies and with a minimum of time effort. The communication network should provide communication services with clearly defined quality levels, which simply can be used without understanding of how these communication services are realized.

3.1.2 Isolation

Many applications, with different QoS requirements, will use the same network. For instance, in a manufacturing environment, industrial control will coexist with the control of autonomous vehicles, manufacturing operations management, video monitoring, building-automation, etc. The priority of these applications from a productivity and safety point of view is often different, and their network resource consumption, too. For instance, monitoring cameras in a factory hall readily surpass the needed network capacity of fire-safety applications, but connectivity for the latter absolutely has to be available at all times. In practice, vertical applications will, at a minimum, be virtually separated from each other. Also, different actors with different roles will need access to the same network. For instance, factory maintenance might be delegated to an external organization, which needs dedicated access to only the machinery it is responsible for. For an appropriate use of the infrastructure, all applications and tenants may not adversely influence each other. For instance, huge communication resource demands for autonomous vehicles may not adversely impact motion control.

3.1.3 Multicast

Domain multicast is used for some automation applications.

3.1.4 Multi-tenancy

Vertical applications increasingly need to handle different stakeholders who are using the same network for running their services. Examples are operation, maintenance, emergency response, etc. This approach has to be supported while still assuring the communication service quality level and excluding conflicts between the stakeholders' interests. This is especially the case if a provider network is used.

3.1.5 Network recovery

Not only should it be possible to isolate communication services consumed by different applications and/or tenants against each other (see isolation), but networks should also provide functionality that regulates the network recovery and reconnection of UEs in a controlled fashion. For instance, in a factory setting, after recovery from a network failure, industrial control application should be provided with communication service access before the outbound logistics applications.

3.1.6 Quality of service (QoS) description

Distributed industrial solutions do not stop at national or service provider borders. Therefore, a common understanding and definition of industry-grade QoS across national borders and between providers would be helpful. This is the only way to provide service guarantees beyond connectivity in an end-to-end fashion. To assure that such end-to-end services can be setup in a timely manner, fundamental industrial service / SLA profiles including the required monitoring should be available, globally accepted and offered. By so doing, long lasting negotiation periods with several network service operators and undue overhead when merging two networks can be avoided.

3.1.7 Service response (Negotiation of QoS levels)

Some automation applications can operate at more than one communication QoS setting. Therefore, if a certain QoS level is requested by the application but cannot be met by the network, an alternative should be proposed by the network. For example, if the requested end-to-end latency (i.e. the communication service delay from an application point of view) of 10 ms cannot be guaranteed, the communication service indicates what end-to-end latency is instead feasible. The automation application has then the option to request communication services at a refined QoS level.

3.1.8 Service deployment time

Today, end-to-end services traversing many network domains, covering large distances or asking for specific quality properties need a long time (in the order of weeks to months) to be setup by the service provider. The reasons for this are suboptimal processes, technical inflexibilities, required manual interventions, missing suitable interfaces, etc. For remote services on demand and many other services this is not acceptable. Significantly reduced lead times of approximately several hours are needed.

3.1.9 Simplified approvals

Industrial solutions are foreseen for international use. In many cases, approvals or even certifications have to be obtained before the solutions can be imported and operated. This includes the approval or certification of communication solutions, especially if these solutions leverage wireless interfaces. Region/nation-specific approval or certification procedures which are not mutually recognized, are very cumbersome and expensive. Thus WIA systems should be able to successfully pass such approval or certification processes.

3.1.10 Technology availability (long-term availability of technology and the related infrastructure)

The lifetimes of industrial solutions are typically in the range of several decades. In order to ensure continuity, any underlying communication solution has to be available throughout the whole lifetime. Therefore an availability of WIA systems (components, spare parts, and infrastructure) over at least 20 years has to be assured. In this context also backward compatibility is of major importance.

3.1.11 Non-standard operating conditions

The absence of low-voltage power supply can be an issue in the field, creating the need for battery- or energy-harvester-powered ultra-low-power area networks with a corresponding low bandwidth. For battery powered WIA devices a lifetime of than 10 years (and more) is needed.

Harsh environments, including wind and weather, vibrations, heat, dust or even hazardous gases may also be a challenge for communication equipment.

3.1.12 Operation of local WIA network infrastructures

Leveraging the full potential of WIA systems can only be achieved if from the very beginning of the setup and operation the wireless network infrastructures can be done also in a local and closed environment without the involvement of a third party network provider and without sharing the infrastructure with other (potentially less controlled) users/applications.

The need to keep the operation of local/closed wireless networks in the responsibility of the industrial operator are mainly due to system criticality: the dependence on third parties is minimized, the transparency in the level of compliance with required quality levels is intrinsically given, and responsibilities and liabilities are much easier to determine. All this leads to a significantly reduced risk for the industrial operator. In addition, maintenance strategies of the industrial solutions will be very different to the ones applied by a third party network service operator.

3.2 Characteristics of radio propagation in WIA environment

The environment of WIA applications typically differs from those of applications in office and urban environments. Industrial environments in general are characterized by large surfaces of metal and cluttered spaces. These industrial environments can be differentiated in indoor environments like factory halls and outdoor environments like process plants.

Factory halls are full of machines, machine centres, stacks of material and shelves, which are in most cases made of metal. Also rooves and walls are often made of or covered by metal. These large amounts of metal surfaces and obstacles cause lots of reflections.

Also in process plants reflections are part of the radio propagation environment. The reflections are generated by tubes and tanks, which can be distributed over large areas.

WIA applications utilize spectrum with different propagation characteristics:

- Spectrum to cover areas also under NLOS conditions:
 - Use with moving devices (example: Automatic Guided Vehicles, AGVs);
 - Use with small bandwidth and good penetration of walls (e.g. sensors and actuators).
- Spectrum to cover areas under LOS inside production halls, high density of systems (see Table 2, Connection density for Factory automation):
 - Protection of other systems outside the production halls.

Channel models for these environment would facilitate the development or evaluation of radio systems.

3.3 Coverage

In chapter 3 various typical WIA applications are presented. Depending on the application the required transmission range varies between some meters and one kilometre and the coverage between 100 m² and 1 km².

Considering range, coverage and additional characteristics the applications are subdivided in three main classes. For detailed values for each class see Table 2, row Service Area.

3.4 Mobility

WIA systems can be stationary or mobile, depending on the application. Mobile WIA systems can move with up to 50 km/h. Propagation conditions for moving systems can change between LOS, OLOS and NLOS very quickly.

3.5 Transmitter parameters

3.5.1 Transmit output power/radiated power

The transmit output power or radiated power for WIA varies throughout the world. As an example, the transmit output power for WIA applications in the CEPT is maximum 400 mW e.i.r.p. and in some countries of Region 2 it can go up to 1 W e.i.r.p.

This value is used to enable WIA devices to reach the required range (see Table 2) also under NLOS conditions and to ensure a reliable transmission.

3.5.2 Antenna characteristics

No restrictions on antenna characteristics.

3.5.3 Bandwidth

As different technologies are used, the typical occupied bandwidth for a single device varies between 0.1 MHz and 80 MHz. Specific applications like location tracking may even use the complete available (sub-)band.

Frequency Hopping as well as non-frequency hopping technologies are used.

3.6 Channel access parameters

For maximized spectrum efficiency, including sharing among all wireless industrial applications present, a spectrum sharing mechanism may be appropriate for industrial applications.

An example of that is Frequency Agility. Frequency Agility is the ability of a system to operate according to frequency or channel assignments of a centralized or distributed control mechanism, which will define the configuration of all devices within an industrial site or subarea thereof. Configurations may change over time depending on the application requirements. If non-contiguous spectrum is assigned, then the Frequency Agility feature is supposed to operate across all assigned sub-bands.

4 Deployment scenarios and architectures

4.1 Presentation of system or technology concept

Typical industrial sites are manufacturers of goods or providers at any place within the delivery chain towards these goods (e.g. oil/gas/energy producers, suppliers of parts or components of these goods up to final assembly of the goods, after- production processes such as water/waste management).

Examples of existing communication network solutions are standardized in EN/IEC 61784-2 and EN/IEC 62591 for wireless solutions for so-called PROFINET based on IEEE 802.11/IEEE 802.15.1 and WirelessHART (see EN/IEC 62591) based on IEEE 802.15.4.

Industrial automation requires 'robust' wireless technologies to be used for their wireless links in industrial applications. More and more wireless solutions are being considered nowadays for these applications.

The advantages of wireless are savings of often complex and expensive cabling, cable protection and plugs the increased mobility and flexibility as well as the wear and tear free transmission medium. These advantages are particularly high in the area of:

- Monitoring and mobile worker communication.
- Wireless sensors and actuators at moving parts.

Different functions can be mastered substantially more efficient by a wireless network of data acquisition terminals, robotic type equipment or automated guided vehicles.

For the sensor and actuator type of applications in industrial automation, the main requirement is the real time behaviour. Real time means a maximum response time defined by the type of application. E.g. on the factory floor of discrete manufacturing, very short latencies of a few milliseconds and a very high reliability (high robustness) is necessary in order to avoid interruptions in the manufacturing process.

In higher levels of the automation hierarchy e.g. at the control or enterprise level, the data volume rises, so throughput, security and reliability becomes more important, but real-time communication requirements decrease.

To meet these requirements, both application categories require specific wireless technologies for specialized sensor/actuator networks. Some technologies being developed for these applications are listed above.

Industrial automation equipment is typically designed in a way that it is not impacted by other wireless applications present in the industrial environment. If an important wireless link would be interrupted, or not respond instantaneously, appropriate measures will take effect immediately.

To achieve the required performances for different industrial wireless applications, it is important to achieve either short latencies or high throughput, in addition to range and reliability, etc. Therefore, industrial users very much depend on the chosen technical solutions for their seamless operational procedures, i.e. a high dependability is envisaged.

In addition, the manufacturing processes require often to use more than one wireless technology simultaneously within the same area or environment. One option to prevent disruptions by interference is to use a coexistence management system in industrial automation applications according to IEC 62657-2 or using any other appropriate sharing mechanisms meeting the specific demands of the industrial applications.

4.2 Deployment scenarios

In a larger industrial plant, if a chemical or oil-/and gas industry process plant ("process automation") or e.g. an automotive discrete manufacturing plant (discrete or "factory automation"), there are and will be always many different wireless systems and technologies for different purposes in parallel to each other (partly or completely overlapping).

The subdivision of such systems into three main classes can be typically done according to Table 2 into:

- Cell or sub-unit automation;

Lowest control system level, can be a part of a line in an automotive plant or a normal discrete manufacturing cell or a sub-unit in process automation (e.g. a reactor with a local control to which sensors and actuators are connected). Typically lower range (e.g. 10 m to 30 m range) but most demanding for latency and robustness, are capable to live with fast movements, integrated antennas and many obstacles (nearly complete shielding).

- One such cell unit has one wireless system with in average 30 devices.
- Up to 10 such units/manufacturing cells can be in close proximity, so that their interference area overlaps.
- The area related local device density at 10 m range therefore is typically 10×30 devices per $10 \times 10 \text{ m}^2$ or 0.33 to 3 devices per m^2 (at 30 m to 10 m range respectively).
- The cell automation data packets as such are typically quite small and have 16 octets on air (e.g. 4 octets of user data, 12 octets for addressing, control and error protection) and have to be sent every 50 ms in each direction.

– factory hall or plant sub-unit automation;

Medium Control System level, where e.g.:

- a) whole production lines or moving applications (e.g. moving through a factory hall in discrete manufacturing e.g. automated guided vehicles, rail hanging power screwdrivers), or
- b) whole production units in process automation:
 - Larger area (e.g. $100 \text{ m} \times 100 \text{ m}$) are covered, for example, by an IEEE 802.11 device or a mesh type technology (TDMA schemes used).
 - Average of 100 devices with low latencies.

Also here the master uses a higher duty cycles and high power to cover the range without line of sight:

- Up to 5 such independent systems can be within range of each other.
- The area related local device density at 100 m range therefore is approximately 5×100 devices per $100 \times 100 \text{ m}^2$ or 0.022 per m^2 at 100 m range.
- The hall/sub-unit automation data packets as such are typically medium size with 200 octets on air (e.g. 140 octets of user data, 60 octets for addressing, networking, control and error protection) and have to be sent every 200 ms in each direction.

– plant level automation

Control system level covering up to the whole plant, typically an industrial mesh technology:

Able to cover e.g. $1 \text{ km} \times 1 \text{ km}$ but typically with mesh technology to increase robustness against typical industrial influences (moving obstacles, interference).

- One such mesh system can have up to 1 000 connected devices, but each device only having to cover a smaller range (100 m) and the mesh covers the larger distances needed, without excessive power needs.
- There may be up to 3 independent mesh networks operating in parallel in the whole plant. Up to maximum of 50 devices within 3 clusters can be within range of each other.
- The local device density at 100 m range therefore is approximately 50 devices per $100 \times 100 \text{ m}^2$ or 0.025 per m^2 at 100 m range.
- The plant level automation data packets are typically medium size with 105 octets on air (e.g. 50 octets of user data, 55 octets for addressing, networking, control and error protection) and have to be sent every 500 ms in each direction.

All of these 3 levels are operated in parallel (partially or completely overlapping radio area), and often by different operators and connected to different Control Systems. Each of the many wireless systems has to be allowed to switch on and off and vary the number of connected active devices and data amount transferred, depending of the needs of the many different production cells/sub-units/ lines in order to maximize individually production, quality, safety and do service, troubleshooting and installation work on the productions units.

Parallel means that in most parts of the plant the three ‘wireless’ classes have overlapping coverage, preferably in the same frequency band. This provides the opportunity for maximal flexibility of coexistence management, increasing spectrum efficiency, limited-industrial-interference, power efficiency (range) and bending/damping by obstacles.

FIGURE 15

Example of a 1 plant production with 10 production halls and 50 manufacturing cells

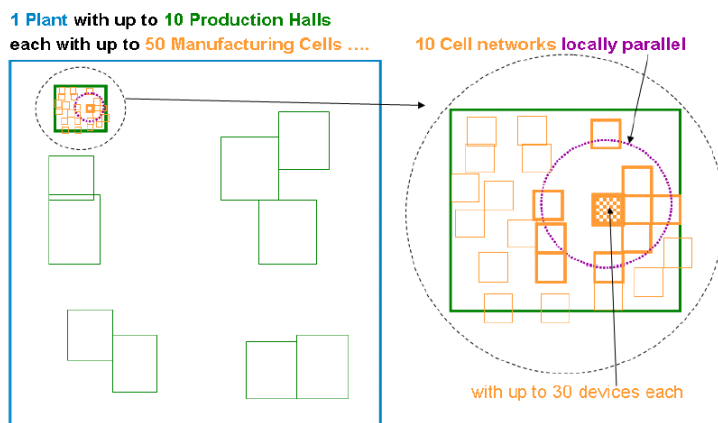

FIGURE 16

Example of hall wide networks, up to five locally parallel

Hall wide networks, up to 5 locally parallel

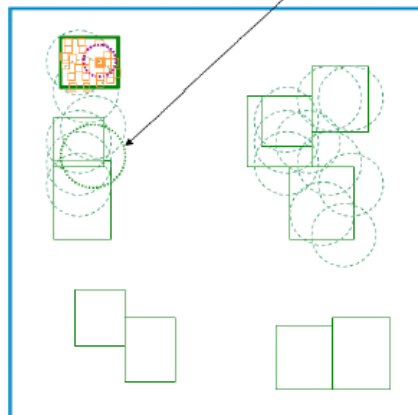

FIGURE 17

Example of plant wide networks, up to three parallel

Plant wide networks, up to 3 parallel
~ up to 250 nodes parallel

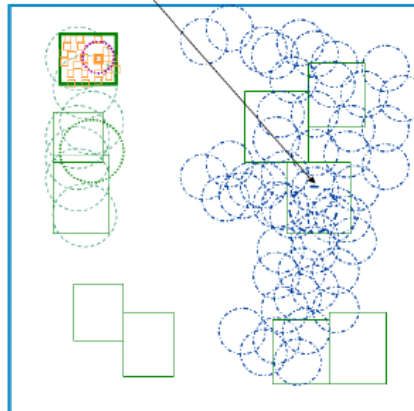

FIGURE 18

Example of a combination of three classes

Plant w. Plant level type networks and
Production Hall type networks and
manufacturing cell type networks

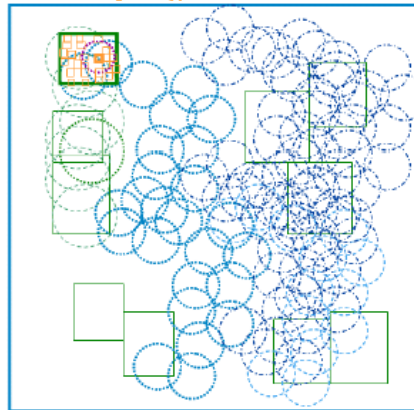

TABLE 2

Example unit density

	Manufacturing cell	Factory hall	Plant level
Indoor/outdoor application	indoor	mostly indoor	mostly outdoor
Service Area L × W × H [m ³]	10 × 10 × 3	100 × 100 × 10	1 000 × 1 000 × 50
Number of devices (typically)	30	100	1 000
Number of parallel networks (= clusters)	10	5	3
Number of such clusters per plant	50	10	1
Min. Number of locally parallel devices	300	500	250
Update time [ms]	50	200	500
Network Type	Star	Star/Mesh	Mesh
Typical operational distance	Depends on individual use case and frequency of operation.		

5 Information on spectrum usage for WIA applications

5.1 Region 1

In Europe the band 5 725–5 875 MHz is currently already in use by various technologies. These devices comply with current regulation for short-range devices (Decision 2017/1483/EU amending Decision 2006/771/EC, ERC Recommendation 70-03) and typically operate as non-specific short-range devices.

In Europe the transmit power of devices operating in 5 725–5 875 MHz is limited to 25 mW e.i.r.p. according to Decision 2017/1483/EU, which also limits the range and reliability and thereby also the range of possible applications. ETSI EN 300 440 addresses the technical conditions for the use of this band.

In addition, ERC Recommendation 70-03 includes the possibility to use of this frequency band for WIA applications up to 400 mW, given the implementation of appropriate spectrum access and mitigation techniques. These conditions of use are included in ETSI EN 303 258.

Today also RFID systems are being implemented in the band 5 725–5 875 MHz for identification, tracking and real-time location applications. These RFID systems use active tags transmitting with power levels up to 25 mW.

5.2 Region 2

In Region 2 countries, use of the 5 725-5 875 MHz band are open for various technologies in accordance with CITEC Recommendation PCC.II/REC.11(VI-05). The band 5 725-5 850 MHz, is made available to license-exempt devices with a transmit power of up to 1 W e.i.r.p..

Annex 2

Wireless smart grid applications currently used in China

1 Introduction

With the rapid development of big data, cloud communications, mobile communications and Energy Internet, a large number of intelligent devices will emerge in the field of smart grid. It is expected to reach 17 million smart access terminals in China by 2020. There are more than 10 kinds wireless smart grid applications including distribution automation, electricity information acquisition, distributed generation monitoring, electric vehicle charging stations, video surveillance, and so on. More requirements and challenges are proposed for wireless networks that transmit smart grid applications. It is necessary to build a private broadband wireless communication network with low cost, large coverage, high reliability, high security and broadband transmission capability.

In some countries and regions, frequency bands have been assigned to stations for smart grid applications, as detailed in Report ITU-R SM.2351-2. In order to satisfy the requirements of wireless smart grid application, Ministry of Industry and Information Technology of China (MIIT) allocated dedicated frequency resources (223-235 MHz, called 230 MHz in this annex) to energy industry in September 2018.

SWIN system (230 MHz discrete multi-carrier power wireless communication system) using 230 MHz frequency band has been adopted by State Grid Corporation of China. The system has been tested in Haiyan of Zhejiang, Jinjiang of Fujian, and Wulong of Chongqing 3 cities in China for large-scale trial.

IoT-G 230 system (230 MHz discrete multi-carrier electric wireless communication system) using 230 MHz frequency band has also been adopted by State Grid Corporation of China. The system has been tested in Suzhou, Jiangsu Province in China and is planned for large-scale deployment in 2019.

2 Typical wireless smart grid applications

2.1 Distribution automation

The distribution automation business includes automatic monitoring, control of the distribution network, power distribution information acquisition, feeder automation, grid analysis and interconnection with related application systems.

Data services for distribution automation includes telemetering uploaded by terminal, tele signalization uploaded by terminals, the general call command issued by the service base station, the line fault location and isolation, and the telecontrol command during recovery. The amount of uplink traffic is larger than that of downlink.

2.2 Electricity information acquisition

The business of electricity information acquisition includes automatic collection of electricity information, measurement anomaly monitoring, power quality monitoring, power analysis, power management and so on. Data service for electricity information acquisition includes the state quantity acquisition information uploaded to the service base station and the general call command issued by the service base station. The amount of uplink traffic is larger than that of downlink.

2.3 Electric vehicle charging stations

In order to implement electric vehicle charging station management, data information including charging navigation, status inquiry, charging reservation, fee settlement should be supported via information exchanging between charging stations and vehicle networking platform. Data service for electric vehicle charging station includes call metering and billing commands issued by the service base station, status and metering information uploaded by charging station.

2.4 Distributed generation monitoring

The distributed generation monitoring system can realize distributed generation operation monitoring and control. The system has functions such as data acquisition and processing, active power regulation, reactive power control, scheduling and coordinated control, and interconnection with related business systems. The communication between the distributed generation monitoring terminal and the service station system is point-to-point communication, and the data transmitted between the service station and the terminal includes power quality monitoring, measurement and control, and gateway measurement information.

2.5 Millisecond-level precise load control

Millisecond-level precise load control is a service in the production area of the power grid. When serious HVDC (high-voltage direct current) transmission fault happens, the service is used to quickly remove interruptible less-important load, such as electric vehicle charging piles and non-continuous production power supplies in factories. It consists of data communication between the control primary

station and the load control terminals, such as the total amount of interruptible load, load shedding control commands, etc. From the beginning of the fault information collection to the load success shedding, the transmission delay is required to be less than 50 ms. For security reasons, the service must be completely isolated from services in management areas.

3 Features of basic smart grid applications

The main features of four basic smart grid applications are shown in Table 3.

TABLE 3
Typical characteristic for wireless smart grid applications

	Distribution Automation	Electricity Information Acquisition	Distributed Generation Monitoring	Electric Vehicle Charging station	Millisecond-Level Precise Load Control
Data rate	2.4 kbit/s	1.05 kbit/s	4 kbit/s	8 kbit/s	22.4 kbit/s
Latency	Telemetry delay < 3 s Telesignalization delay < 3 s Telecontrol delay < 2 s	Control command Response time ≤ 5 s Data recall time < 15 s	Telemetry delay < 60 s Telesignalization delay < 60 s Telecontrol delay < 5 s	Transmission delay < 3 s	Transmission delay < 50 ms
Reliability (BLER)	10^{-4}	10^{-4}	10^{-4}	10^{-4}	10^{-4}

4 Technical aspects

Due to the difficulty in deploying fibre-optic communication networks, it is imperative to develop a private power wireless communication network with flexibility, and controllability advantages.

A variety of non-IMT wireless technologies have been used in smart grid applications such as ZigBee, Bluetooth, Wi-Fi, 6LoWPAN and Z-Wave. In order to satisfy the reliability and security requirements, a private power wireless network using licensed spectrum is needed. Many countries and regions have begun to allocate licensed frequency resource for private wireless networks of smart grid. In China, Ministry of Industry and Information Technology of China has re-planned 230 MHz frequency band. The 230 MHz band as licensed frequency resource has been allocated to energy industry. Furthermore, both SWIN and IoT-G 230, as private broadband wireless systems for wireless smart grid applications, are being constructed.

4.1 Introduction of SWIN System

Benefit from carrier aggregation, spectrum sensing and software radio technologies, the SWIN system effectively utilizes narrowband spectrum resources and simultaneously coexists with the legacy narrowband radio systems. The system has the advantages of wide coverage, large capacity, high spectral efficiency, strong spectrum adaptability, high security, good reliability and so on. SWIN system is a low-cost, high-yield broadband wireless communication solution for wireless smart grid applications. The system improved the frequency efficiency, from 0.768 bps/Hz to 3 bps/Hz, which strongly promotes the development of China's Energy Internet.

The key technical items of SWIN are shown in Table 4.

TABLE 4
Key technical items of SWIN

Item	Value
Supported frequency bands	223-235 MHz
Frame length	25 ms
Subcarrier spacing	2 kHz
Nominal operating range	3-30 km
Support for mobility	Yes
Peak data rate (uplink/downlink)	14.4 UL/7 DL Mbit/s (7M BW)
Duplex method	TDD
Multiple access methods	TDMA and FDMA
Channel coding	Turbo coding, Tail biting convolutional coding
Modulation	QPSK/16QAM/64QAM

For SWIN system, the downlink and uplink transmissions are organized into radio frames with 25 ms duration. Each radio frame consists of 5 subframes of length 5 ms. The supported uplink-downlink configuration is listed in Fig. 19. For each subframe in a radio frame, 'D' denotes a downlink subframe reserved for downlink transmissions, 'U' denotes an uplink subframe reserved for uplink transmissions and 'S' denotes a special subframe with the three fields DwPTS, GP and UpPTS.

A sub-band in physical layer occupies 25 kHz, which has 11 consecutive subcarriers of 2 kHz. A digital filter is used for each sub-band in order to avoid interference from/to other narrowband radio systems. Multiple sub-bands can be aggregated to implement broadband transmission.

FIGURE 19
SWIN frame structure

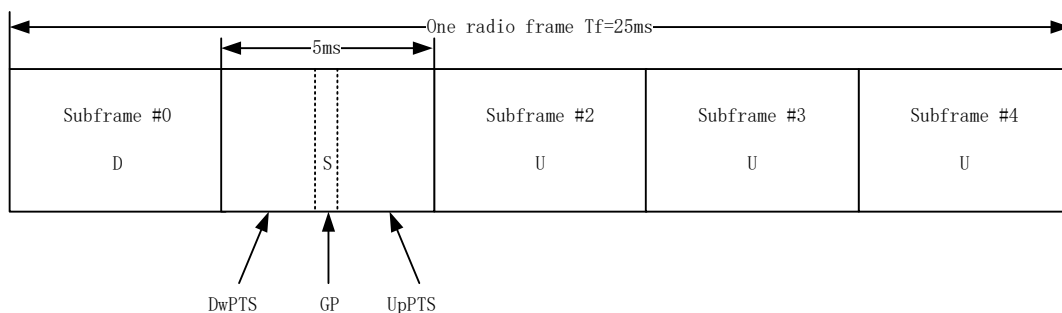

4.2 Introduction of IoT-G 230 System

IoT-G 230 aims to provide wireless connections for smart grid applications such as millisecond-level precise load control, distribution automation, electricity information acquisition, distributed generation monitoring, electric vehicle charging pile, and etc. The key technical aspects of IoT-G 230 are shown in Table 5.

TABLE 5
Key technical items of IoT-G 230

Item	Value
Supported frequency bands	223-235 MHz
Frame length	10 ms
Subcarrier spacing	3.75 kHz
Nominal operating range	3-30 km
Support for mobility	Yes
Peak data rate (uplink/downlink)	11.27 UL/9.92 DL Mbit/s (7M BW)
Duplex method	TDD
Multiple access methods	TDMA and FDMA
Channel coding	Turbo coding, Tail biting convolutional coding, Reed-Muller coding
Modulation	QPSK/16QAM/64QAM

For IoT-G 230, downlink and uplink transmissions are organized into radio frames with 10 ms duration. Each radio frame consists of 5 slots of length 2 ms numbered from 0 to 4. Slot 2 consists of DwPTS, GP and UpPTS, the lengths of which are 1/3 ms, 2/3 ms and 1 ms, respectively, as shown in Fig. 22. Slot 0 and 1 and DwPTS are always reserved for downlink transmission. UpPTS and Slot 3 and 4 are always reserved for uplink transmission. Hyper-frame of length 10 240 ms is used, which consists of 1 024 frames, as shown in Fig. 20. The hyper-frame number cyclically runs from 0 to 1 023.

A subcarrier spacing of 3.75 kHz is used and that each 25 kHz carrier in the physical layer consists of 6 subcarriers. A digital filter is used for each sub-band in order to avoid interference from / to other narrowband radio systems. Multiple 25 kHz narrowband can be aggregated to achieve broadband transmission.

FIGURE 20
IoT-G 230 frame structure

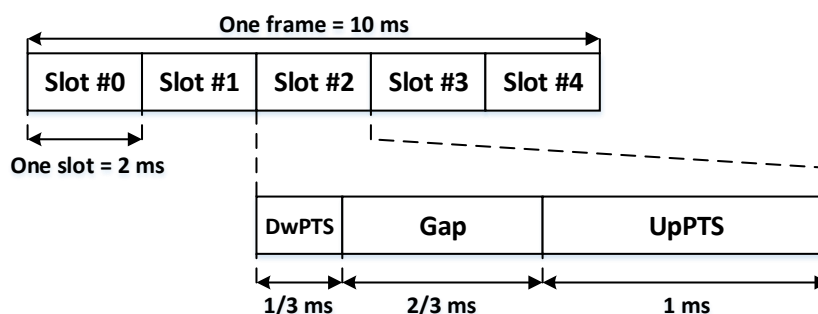

5 Frequency Bands

Currently, there are two types of spectrum assigned to station for smart grid application, licensed and licensed exempt condition. See Table 1 in section 4.3 of Report ITU-R SM.2351-2 for details.

With the development of smart grids, the demand for the construction of private broadband wireless networks for smart grid applications is becoming more and more urgent.

In China, 230 MHz frequency band was originally allocated to different industries, such as energy, geology and mining, to transmit data transmission, mainly using 25 kHz narrowband transmission. The original frequency usage method cannot meet the broadband transmission requirements. Therefore, Ministry of Industry and Information Technology of China (MIIT) has re-planned the band.

Taking into account the frequency usage requirements of broadband and narrowband systems, MIIT recently allocated 223-235 MHz frequency band for wideband TDD systems and narrowband systems. At the same time, technologies such as carrier aggregation and dynamic spectrum sharing technologies are introduced in this frequency band to meet the development needs of the industry's broadband wireless network applications.

6 Development of private power wireless network in China

At present, the State Grid Corporation of China has established several private broadband wireless networks basing SWIN technology in three provinces including Zhejiang, Chongqing, Fujian.

The SWIN wireless network built in Haiyan County (Fig. 21), Zhejiang Province has covered more than 500 square kilometres. Nearly 12 000 power intelligent terminals and 11 base stations have been deployed. The wireless smart grid applications such as distribution automation, electricity information acquisition, distributed Generation monitoring, electric vehicle charging stations, video surveillance etc. are implemented by using SWIN system. Through discrete carrier aggregation and spectrum sensing technologies, the network effectively utilize the discrete frequency resource of 230 MHz band, and can meet the smart grid broadband transmission requirements.

Until now, the SWIN-based broadband wireless network in Haiyan County has run stably for eight years. The transmission rate is improved significantly, and the data acquisition success rate is over 99.7%. SWIN system has realized the support of typical smart grid applications, and has a good scalability for the evolution of the smart grid.

FIGURE 21
Deployment diagram of SWIN-based private power wireless network in Haiyan

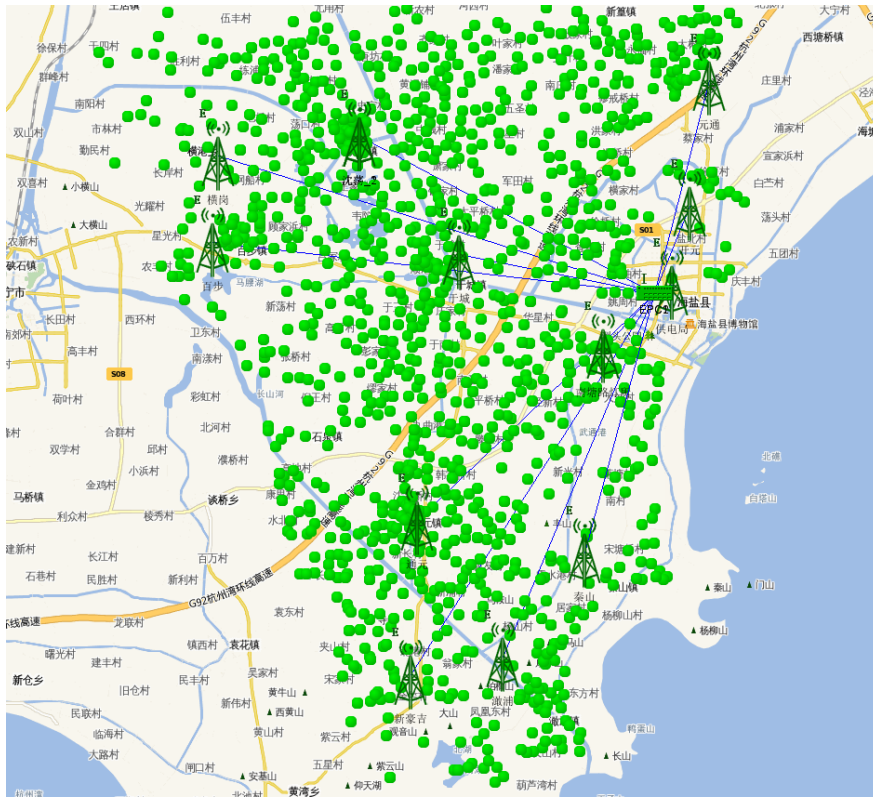

The State Grid Corporation of China has completed the laboratory test for IoT-G 230 in October 2018, and has completed the field test for IoT-G 230 in November 2018 in Suzhou, Jiangsu Province of China. IoT-G 230 passed all the field test cases including interference tests, system security tests, stability tests, etc. The field test deployment setup and test performance are shown below. IoT-G 230 is planned for large-scale deployment in 2019.

FIGURE 22
Deployment diagram of IoT-G 230 field test in Suzhou, China

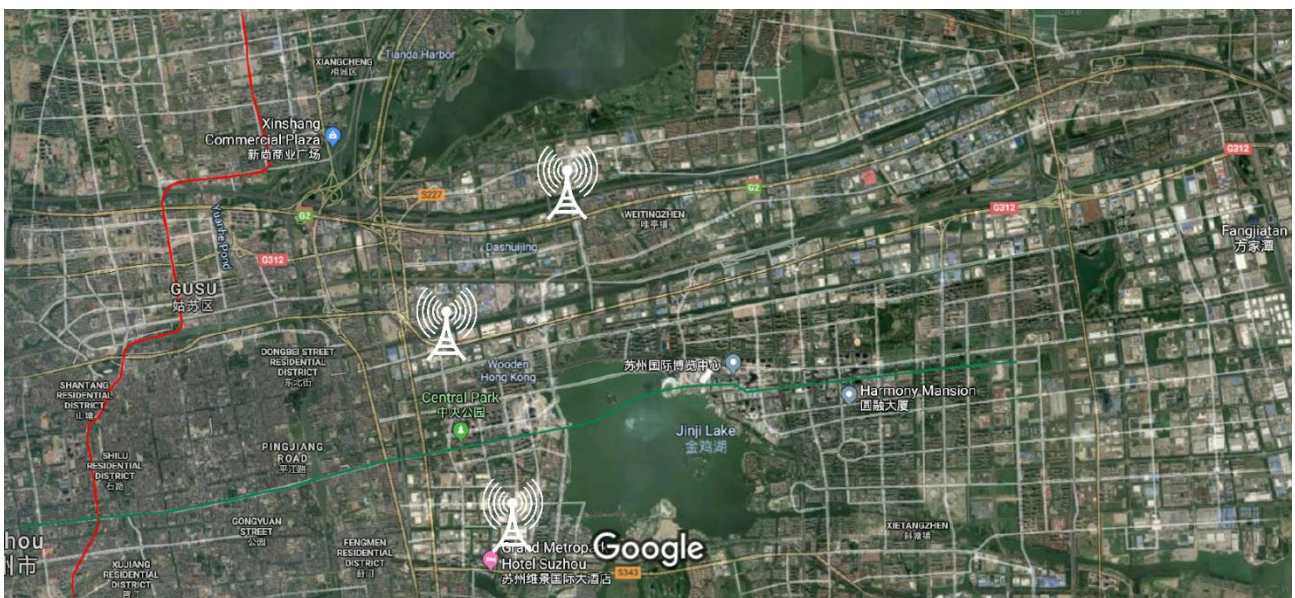

TABLE 6

Lab and field test performance of IoT-G 230

Test case	IoT-G 230 (lab test)	IoT-G 230 (field test)
Terminal uplink data rate (per 25 kHz carrier)	37.9 kbit/s	35 kbit/s
Terminal downlink data rate (per 25 kHz carrier)	33.9 kbit/s	31.3 kbit/s
Air interface uplink latency	20 ms	25 ms
Air interface downlink latency	18 ms	35 ms
Cell uplink throughput	10.03 Mbit/s (7M BW)	820 kbit/s (3 terminals)
Cell downlink throughput	8.8 Mbit/s (7M BW)	700 kbit/s (3 terminals)

Annex 3**MTC applications based on 3GPP technology not IMT: MulteFire****1 Introduction**

This Annex provides information on MulteFire technology which is design to operate on license-exempt bands. MulteFire builds on the key design features of 3GPP Release 13 LAA and Release 14 eLAA to allow for standalone operation without a licensed carrier. MulteFire's detailed features are provided in the following sections. It extends 3GPP LAA/eLAA/eMTC/NB-IoT for standalone operation in license-exempt spectrum under the design criteria of a single global solution framework, fair coexistence between Wi-Fi, Bluetooth, Lora, LAA and eLAA as well as fair coexistence between various MulteFire networks.

The MF Release 1.0 specification was completed in January 2017 [13] and the MF Release 1.1 specification was completed by December 2018. In MulteFire 1.1, which includes MF eMTC-U and MF NB-IoT-U features supporting a wide range of applications from mobile broadband to machine type communications. The MBB feature of MulteFire provides a nominal channel bandwidth of 20 MHz. MF eMTC-U supports a nominal channel bandwidth of 1.4 MHz. MF NB-IoT-U has a nominal channel bandwidth 180 kHz. Both MF eMTC-U and MF NB-IoT-U target enhanced coverage while also reducing device complexity.

This makes MF eMTC-U and MF NB-IoT-U suitable for applications such as process automation or other applications of factory automation.

2 Architecture**2.1 Public Land Mobile Network (PLMN) Access Mode**

In PLMN Access Mode, the MulteFire RAN is connected to a 3GPP Evolved Packed Core (EPC) in a similar manner as an evolved universal terrestrial radio access network (E-UTRAN a.k.a. LTE RAN) is connected to an EPC. Figure 23 presents the reference architecture model for MulteFire PLMN Access Mode.

FIGURE 23
Architecture model for MulteFire PLMN Access Mode

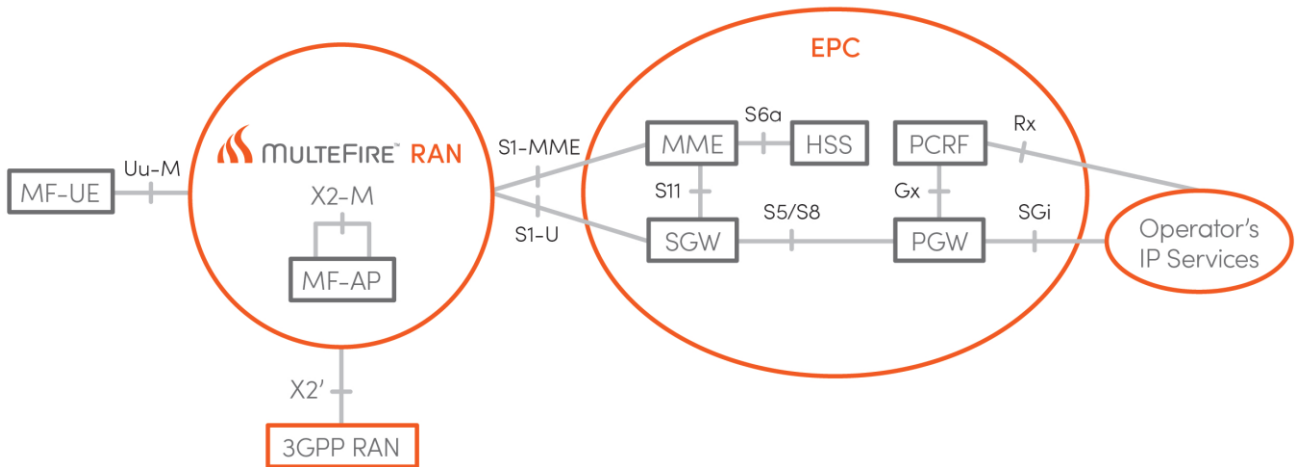

2.2 Neutral Host Network (NHN) Access Mode

NHN Access Mode architecture is Fig. 24 designed for deployment of self-contained MulteFire-based access networks at various locations by various entities. A key design principle is the separation between the access network functions and the service provider functions.

FIGURE 24
Architecture model for MulteFire NHN Access Mode

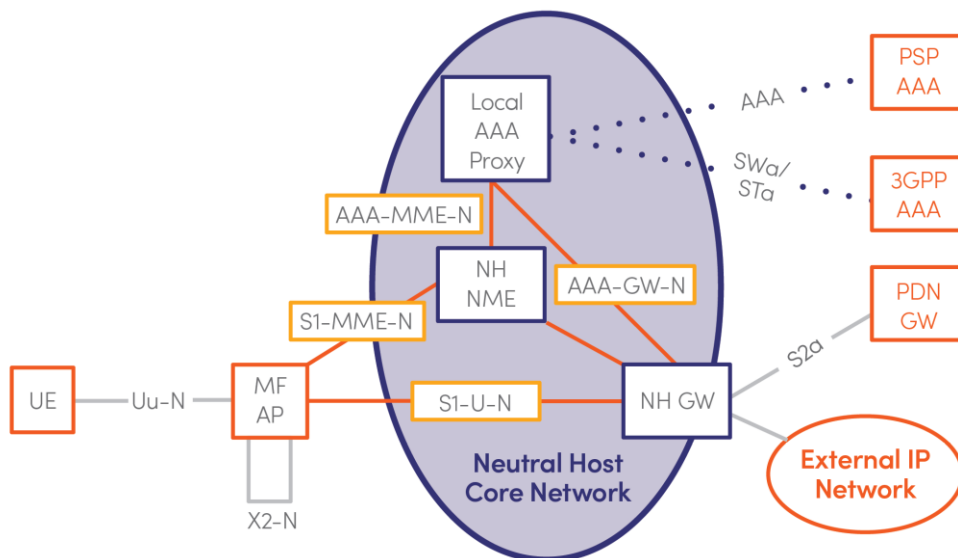

2.3 MulteFire Radio Air Interfaces

MulteFire support three radio interfaces which operate on various bands:

- 1 MBB – utilizes the 5 GHz, and 3.5 GHz bands to support a carrier bandwidth of 20 MHz along with carrier aggregation (CA) mode where several carriers can be combined to increase bit rates to end users. Listen-Before-Talk is the coexistence mechanism which allows coexistence with other networks sharing the spectrum.

- 2 eMTC-U – utilizes the 2.4 GHz band and other frequency band to supports a carrier bandwidth of 1.4 MHz. Instantaneous bit rates of 1 Mbit/s and more realistic sustained bit rates of 350 kbit/s can be supported. Frequency hopping, LBT on the downlink and duty cycle restrictions on the uplink are the coexistence mechanisms for increasing robustness and lowering interference to other technologies.
- 3 NB-IoT-U – utilizes the 2.4 GHz band and other frequency bands. Frequency hopping and duty cycle restrictions are the coexistence mechanisms for increasing robustness and lowering interference to other technologies.

The MulteFire Core Network supports all three radio interfaces.

3 Operation and deployment scenarios

The following applications are examples for industrial wireless applications, whose operation and deployment are supported by MulteFire technology, including port automation, digital automation, etc.

3.1 Port automation

FIGURE 25

Shanghai Yangshan Port²: AGV, Remote Crane Monitoring System, CCTV

Automated Guided Vehicles (AGVs)

- Uplink: Transmission of data related to positions, speeds, sap pressures, and batteries
- Downlink: Transmission of data, such as moving area and turning instruction

Remote Crane Monitoring System

- Container truck: Container raising and lowering instructions
- Tally: Operation instruction
- Crane monitoring and fault alarm indicator

CCTV @ Wireless

- To enable 2k video camera data transmission real time, single connection requires 2 Mbit/s speed.
- As a complementary communication channel, fibre may get broke after certain time usage.

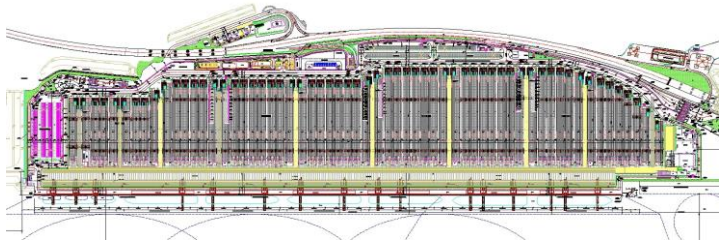

Shanghai Yangshan Port phase IV (largest port in the world): 2,350 meter, 7 berths, 26 double trolley quay cranes, 61 stackings and 120 rail-mounted gantry cranes, 130 vehicles with automated navigation system.

3.2 Digital factory

FIGURE 26

Digital factory

Automated Guided Vehicles (AGVs)

- AGV and mobile robotics
- less than 50ms latency to avoid abnormal stop
- Stable links when mobile access

Production Visualization

- I/O, Alarm, machine status (e.g. rotating speed)
- 1K+ connections per workshop
- Low power consumption for easy maintenance

Property/Asset Management

- Periodically reports of property/asset information
- Location tracking
- Wireless scanner



3.3 Other scenarios

MulteFire could also be used to address other application domains. The industrial and business critical segments³ addressable by MulteFire is illustrated in Fig. 27.

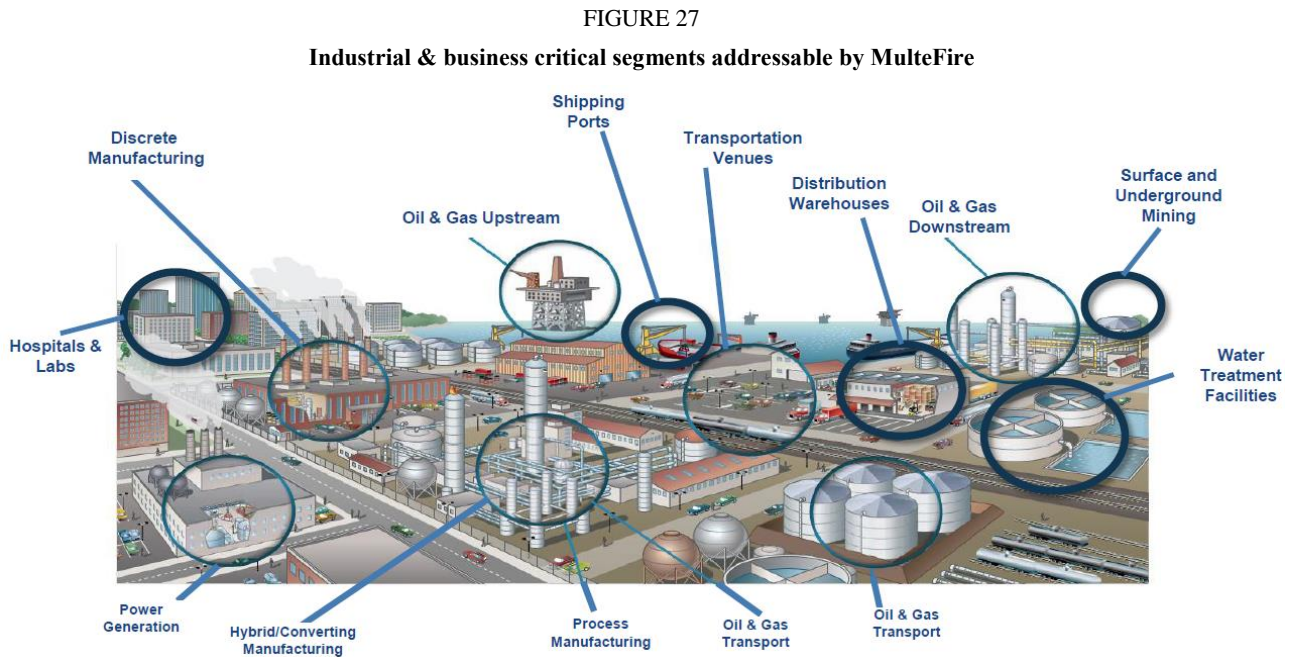

Annex 4

Where to get the standards and specifications mentioned in this Report

CEPT

The CEPT decisions, recommendations and reports can be found at:

<https://www.ecodocdb.dk/>.

CITEL

The CITEL Recommendations can be found at:

<http://www.oas.org/citeldocuments/default.aspx?lang=en>.

CITEL Recommendation PCC.II/REC.11(VI-05) is available at:

<http://www.oas.org/citeldocuments/Download.aspx?id=421>.

² MulteFire Brings Yangshan Port Into Automation Era, Available at: https://www.multefire.org/wp-content/uploads/eLTE-Brings-Yangshan-Port-Into-Automation-Era_MWC18.pdf.

³ MulteFire in the enterprise: Driving innovation and value creation, Available at: https://www.multefire.org/wp-content/uploads/HRI_MF-Enterprise_White-Paper_January-2018_FINAL.pdf.

ETSI

All the ETSI standards and deliverables are available in electronic form at: <http://pda.etsi.org/pda/queryform.asp>, by specifying in the search box the document number.

IEEE

The URL for the IEEE 802.11 Working Group is <http://www.ieee802.org/11>. With support from the IEEE-SA, industry sponsors, and government, a number of IEEE standards are available for download at no cost. This program, entitled the IEEE GET Program™, grants public access to view and/or download these current standards. <https://ieeexplore.ieee.org/browse/standards/get-program/page>

Industrie 4.0

Information about Industrie 4.0 can be found at the following link:

<https://www.plattform-i40.de/I40/Navigation/EN/Home/home.html>.

Further information on Industrie 4.0 can be found also here:

<https://www.plattform-i40.de/I40/Navigation/EN/Industrie40/WhatIsIndustrie40/what-is-industrie40.html>.

MulteFire

The MulteFire specifications are publicly available at:

<https://www.multefire.org/specification/>.
