

Standards for Spectrum Sharing and White Spaces to Bridge Digital Divide

Dr. Apurva N. Mody,
Chairman, IEEE 802.22 Working Group

apurva.mody@ieee.org,

+1-404-819-0314



[Link](#) to the July 2013, IEEE 802, ITU Spectrum Sharing and White Space Standardization Meeting Presentations



Spectrum Sharing, A Digital Opportunity

- **Developed Countries:** More than 500 MHz of spectrum will be required before 2020 to support emerging wireless broadband services and applications.
- **Developing Countries:** Cost effective broadband access is still a challenge in rural areas and developing countries.
- **Spectrum sharing** can create tomorrow's spectrum super-highways. It supports licensed, license-exempt and hierarchical access business models
- **Technologies and Standards** supporting Cognitive Radios, and Database enabled spectrum access exists
- **Regulations** to support spectrum sharing need to be developed

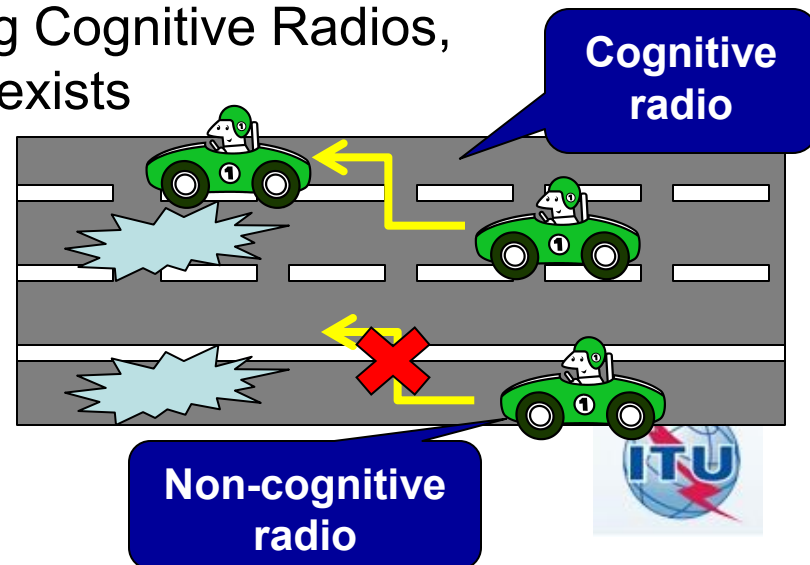

*These are authors' s personal view-points and do not represent the viewpoints of any other organization

IEEE and IETF Spectrum Sharing Standardization Activities

Title	Contributor
<ul style="list-style-type: none"> • IEEE 802.11 (Wireless Local Area Networks) 	Rich Kennedy (IEEE 802.11 WG)
<ul style="list-style-type: none"> • IEEE 802.15.4m (Wireless Personal Area Networks) 	Clint Powell (IEEE 802.15 WG)
<ul style="list-style-type: none"> • IEEE 802.19.1 (Co-existence) 	Stanislav Filin (IEEE 802.19.1 WG)
<ul style="list-style-type: none"> • IEEE 802.22 (Wireless Regional Area Networks and Enabling Technologies) 	Apurva N. Mody (IEEE 802.22 WG)
<ul style="list-style-type: none"> • IETF Protocol to Access White Spaces 	John Malyar , Gabor Bajko (IETF PAWS)
<ul style="list-style-type: none"> • P1900 Standardization Activity (Dynamic Spectrum Access Networks) 	Matthew Sherman , Hiroshi Harada (IEEE DySPAN - SC)



IEEE 802.11AF Wireless Local Area Networks

- Based on the IEEE 802.11ac physical layer, supports multiple concurrent downlink transmissions utilizing MU MIMO (multi-user multiple-input, multiple-output)
- More efficient spectrum use with smart antenna technology, enables
 - More efficient spectrum use
 - Higher system capacity
 - Reduced latency by supporting up to four simultaneous user transmissions
- Provides support for operation in unused TV channels in the VHF and UHF bands
- Multiple operating modes in 6, 7 and 8 MHz channels
 - W (1x channel width)
 - $2W$ (2x channel width)
 - $W + W$ (non-contiguous)
 - $2W + 2W$ (non-contiguous)
 - $4W$ (4x channel width)



Contributor: Rich Kennedy, Chairman, IEEE 802.11AF Task Group. r.kennedy1000@gmail.com, www.ieee802.org/11



IEEE 802.11AF Operation in the TV Bands

- Access to spectrum via geolocation database(s)
- Master device (AP) connection to database; client (STA) dependent on master
- Allows for Registered Location Secure Server (RLSS) to cache the relevant portion of the database(s); allows for central control for campus TVWS network (not in all regulatory domains)

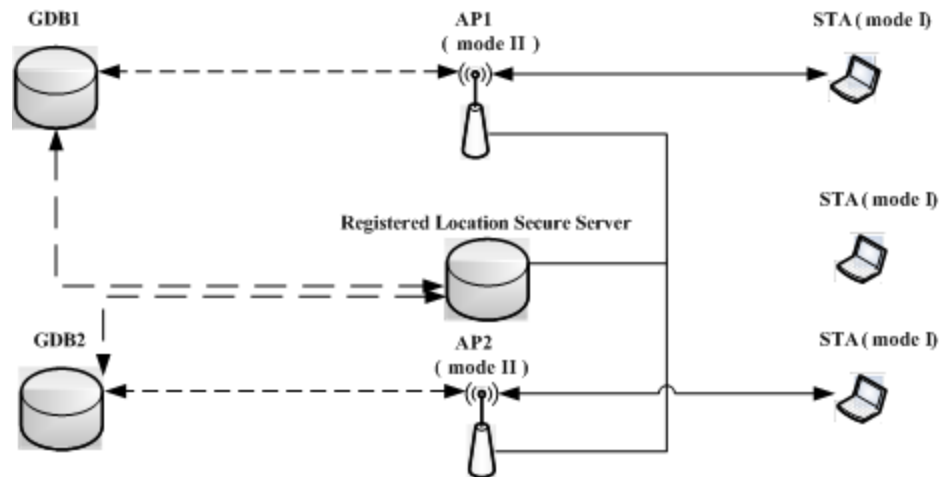

IEEE 802.15.4m – Wireless Personal Area Networks

□ Project Title

IEEE Standard for Local and Metropolitan Area Networks Part 15.4: Low Rate Wireless Personal Area Networks (LR-WPANs) Amendment 6: TV White Space Between 54 MHz and 862 MHz Physical Layer

□ Intro of Draft

This amendment specifies alternate PHYs in addition to those of IEEE Std 802.15.4-2011. In addition to the new PHYs, the amendment also defines those MAC modifications needed to support their implementation.

The alternate PHYs support principally outdoor, low-data-rate, wireless, TV White Space network (TVWS) applications under multiple regulatory domains. The TVWS PHYs are as follows:

- Frequency shift keying (TVWS-FSK) PHY
- Orthogonal frequency division multiplexing (TVWS-OFDM) PHY
- Narrow Band Orthogonal frequency division multiplexing (TVWS-NB-OFDM) PHY

The TVWS PHYs support multiple data rates in bands ranging from 54 MHz to 862 MHz



Contributor: Clint Powell, IEEE 802.15.4m Task Group.
cpowell@ieee.org, www.ieee802.org/15



P802.15.4m

Depiction of Smart Utility Usage Model Utilizing TVWS*

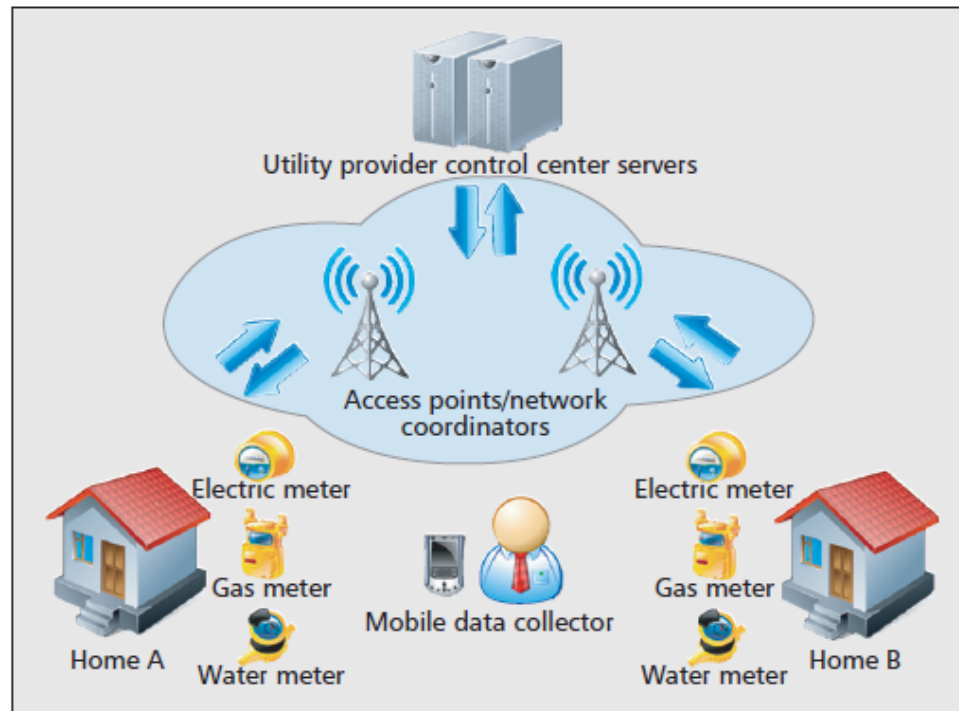

***figure from “Cognitive Communication in TV White Spaces: An Overview of Regulations, Standards, and Technology”, IEEE Communications Magazine, July 2013.**

IEEE 802.19.1 - Coexistence

❑ Project Title

Draft Standard for TV White Space Coexistence Methods

❑ Project Scope

The standard specifies radio technology independent methods for coexistence among dissimilar TV Band Devices (TVBDs) and dissimilar or independently operated networks of TVBDs.

❑ Project status

November 2013: WG letter ballot finished with 91% approval rate

December 2013: Sponsor Ballot started

IEEE 802.19.1

System Architecture

CDIS – Coexistence Discovery and Information Server

CM – Coexistence Manager

CE – Coexistence Enabler

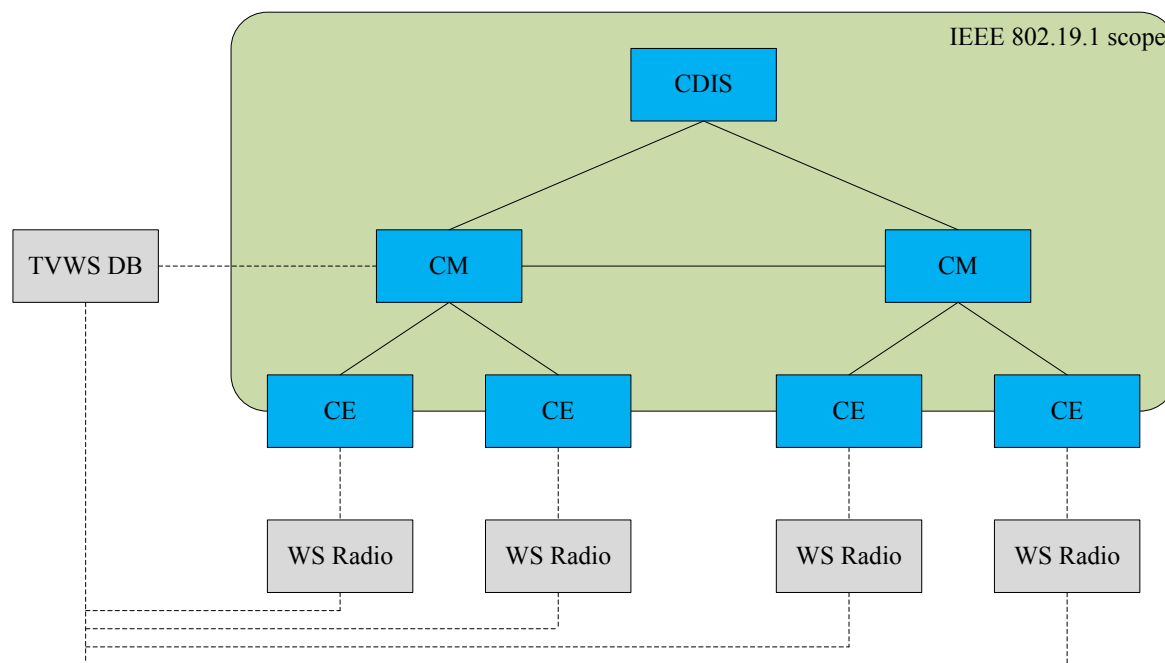

IEEE 802.22 WG on Cognitive Radio Based Spectrum Sharing and Wireless Regional Area Networks

IEEE 802.22 WG is the recipient of the IEEE SA Emerging Technology Award

IEEE 802.22 Standard – Wireless Regional Area Networks: Cognitive Radio based Access in TVWS



802.22.1 – Std for Enhanced Interference Protection using beaconing

802.22.1a – Advanced Beaconing

802.22.2 – Std for Recommended Practice for Deployment of 802.22 Systems

NEW!! Spectrum Occupancy Sensing (SOS) Study Group

802.22a – Enhanced Management Information Base and Management Plane Procedures

802.22b Enhancement for Broadband Services and Monitoring Applications

IEEE
802

Contributors: Dr. Apurva N. Mody, Chairman, IEEE 802.22 Working, apurva.mody@ieee.org,
Dr. Chang-woo Pyo, Vice Chair, IEEE 802.22 WG, www.ieee802.org/22



IEEE 802.22 (Wi-FAR™) Operation and Applications

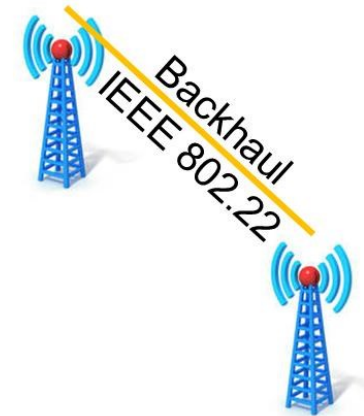
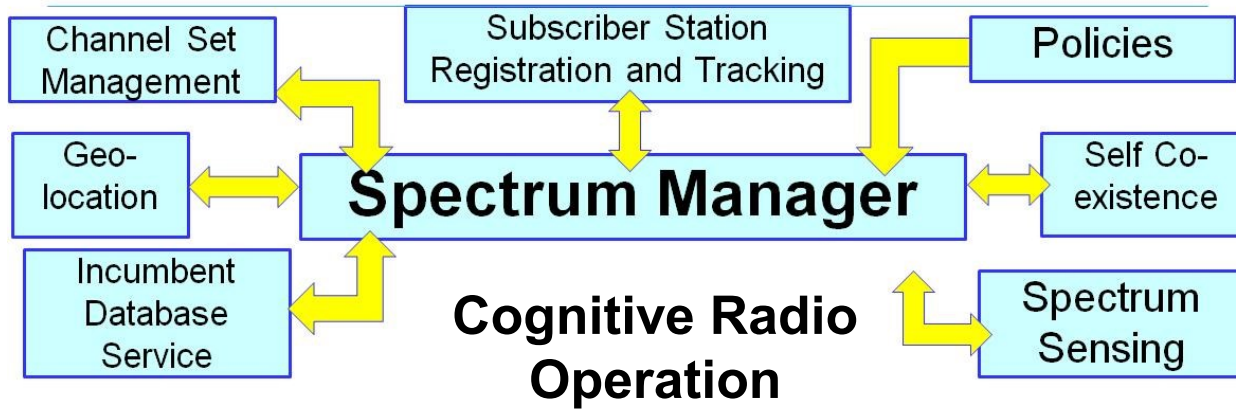

Triple play

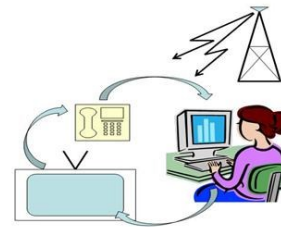

Cellular offload



Critical infrastructure monitoring

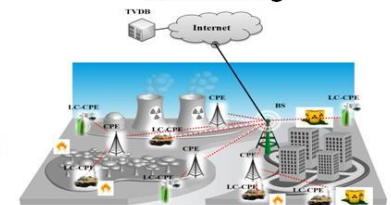

Border protection

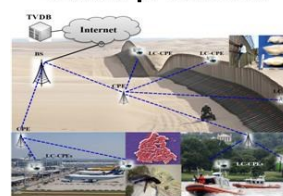

Emergency broadband infrastructure

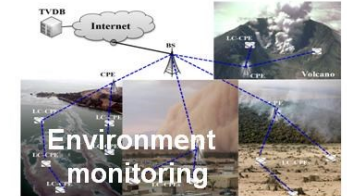
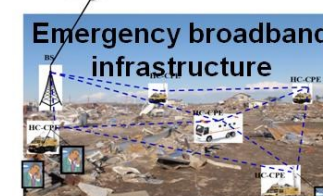

Rural Broadband and Backhaul

Rural Broadband and Backhaul



IEEE 802.22 can support many other applications such as smart grid, wireless access to oil rigs as well as remote medical services

Source: WhiteSpace Alliance. www.WhiteSpaceAlliance.org

IEEE Dynamic Spectrum Access Networks –Standards Committee (DySPAN-SC) Organization

- IEEE Dynamic Spectrum Access Networks (DySPAN) Standards Committee (DySPAN-SC)
 - Originated as IEEE P1900 -> IEEE SCC 41 -> DySPAN-SC
 - <http://grouper.ieee.org/groups/dyspan/>
 - Home to the IEEE 1900 working groups
 - “Owns” the P1900 series of standards...
- Scope (from <http://grouper.ieee.org/groups/dyspan/>)
 - dynamic spectrum access radio systems and networks with the focus on improved use of spectrum
 - new techniques and methods of dynamic spectrum access including the management of radio transmission interference, and
 - coordination of wireless technologies including network management and information sharing amongst networks deploying different wireless technologies

Contributors: Matthew Sherman, Chair, IEEE P1900.5 Task Group
shermanljs@ieee.org



IEEE Dynamic Spectrum Access Networks –Standards Committee (DySPAN-SC) Organization

Working group (WG)

IEEE 1900.1: Standard Definitions and Concepts for Spectrum Management and Advanced Radio System Technologies

IEEE 1900.2: Recommended Practice for Interference and Coexistence Analysis

IEEE 1900.4: Standard for Architectural building blocks enabling network-device distributed decision making for optimized radio resource usage in heterogeneous wireless access networks

IEEE 1900.5: Standard on Policy Language and Policy Architectures for Managing Cognitive Radio for Dynamic Spectrum Access Applications

IEEE 1900.6: Standard on interfaces and data structures for exchanging spectrum sensing information for dynamic spectrum access systems

IEEE 1900.7: Standard on radio interface for white space dynamic spectrum access radio systems supporting fixed and mobile operation

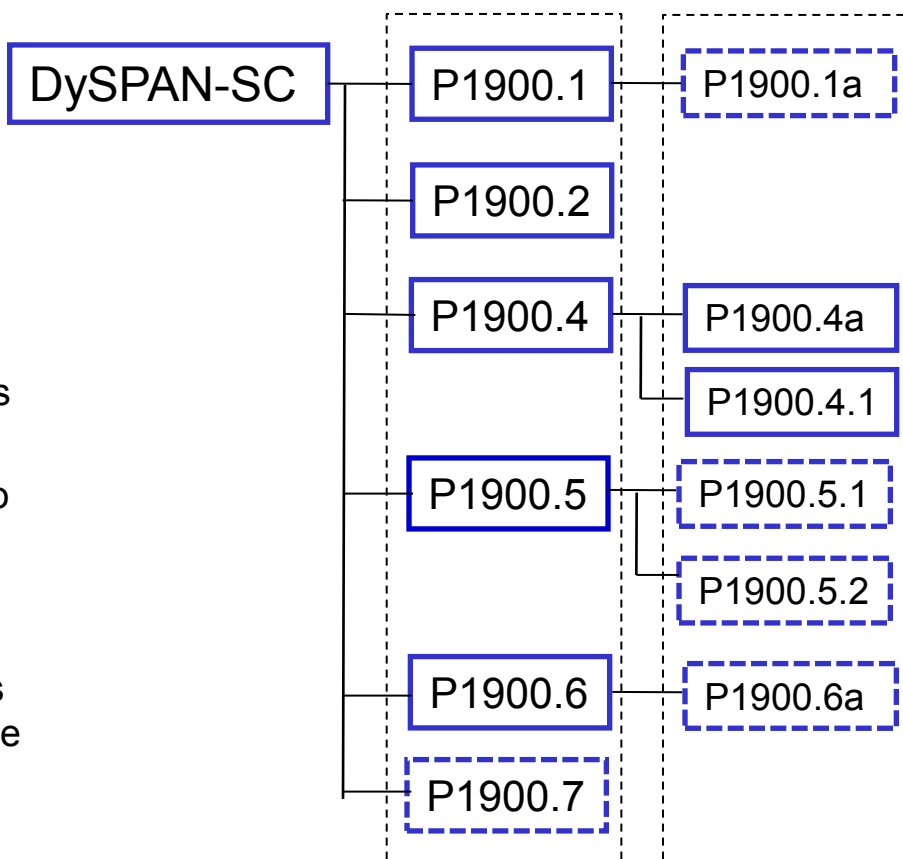

Derived from: Order of Business for 8th General Meeting of IEEE DySPAN.
DCN: SC-13-0038-00-MTNG

<https://mentor.ieee.org/dyspan-sc/dcn/13/sc-13-0038-00-MTNG-august-2013-arlington-meeting-order-of-business.ppt>



IETF PAWS

- IETF is defining a Protocol to Access Spectrum Database in PAWS (Protocol to Access White Space) WG
 - <http://tools.ietf.org/wg/paws/>
- Use Cases and Requirements: RFC6593
 - <http://www.rfc-editor.org/rfc/pdf/rfc6953.txt.pdf>
- Latest Version of the Draft Protocol
 - <http://www.ietf.org/id/draft-ietf-paws-protocol-07.txt>

Contributors: John Malyar, IETF PAWS, jmalyar@iconectiv.com
Gabor Bajko, Chair, IETF PAWS, gabor.bajko@nokia.com



IETF PAWS Protocol

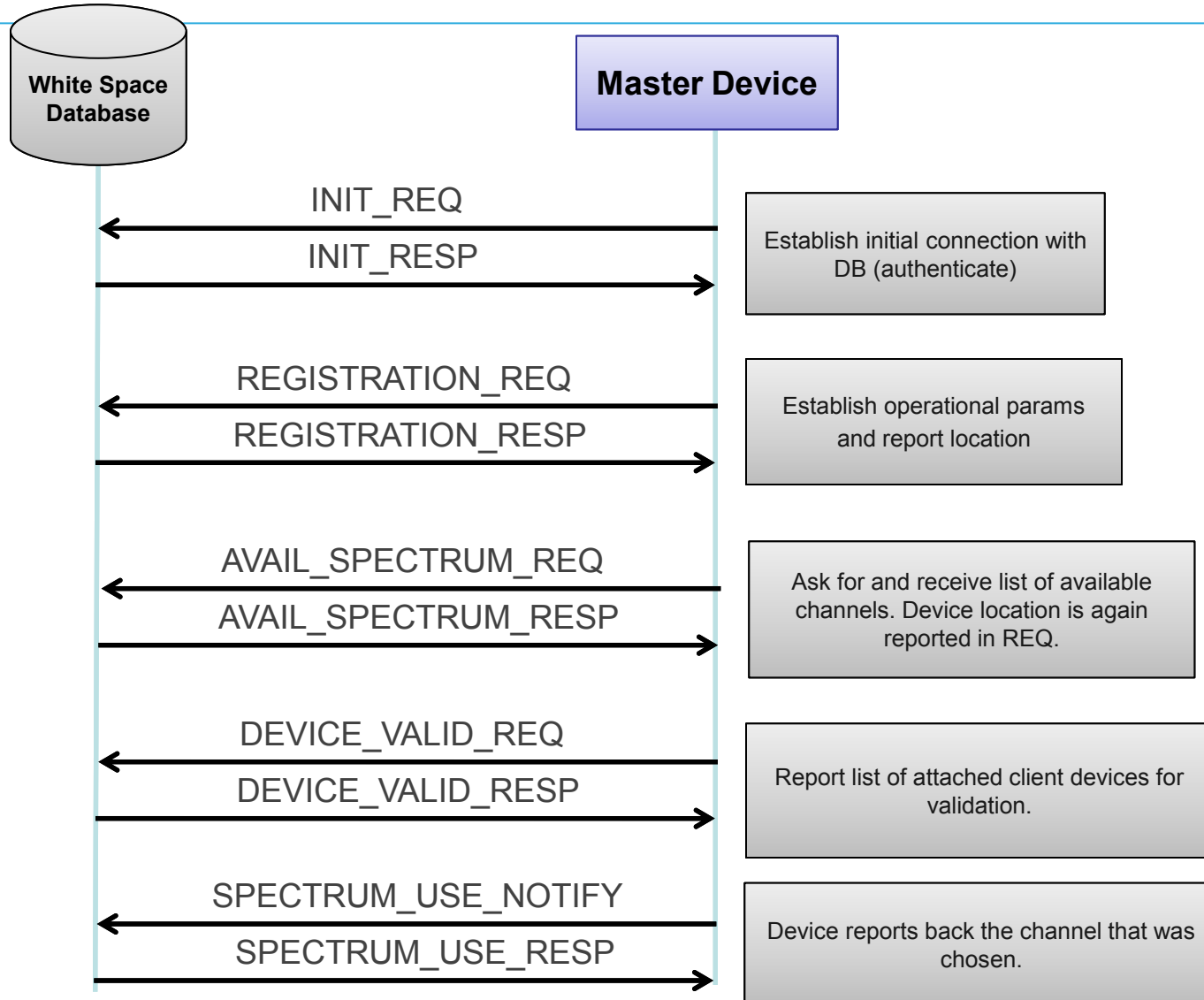

Conclusions

- Spectrum sharing can benefit *developed and developing countries*
- Cognitive Radio technology and use of White Spaces will provide *ubiquitous wireless connectivity* and support many other machine to machine applications
- Spectrum sharing can create *tomorrow's spectrum super-highways*. It supports licensed, license-exempt and hierarchical access business models
- *Technologies and Standards* for Cognitive Radios, and Database enabled Spectrum Access exist
- *Regulations* to support spectrum sharing need to be developed