

International Telecommunication Union

ITU-T

Technical Paper

TELECOMMUNICATION
STANDARDIZATION SECTOR
OF ITU

(09/2020)

GSTP-HNSG

**Technical paper on the use of G.hn technology
for smart grid**

ITU-T

Summary

Technical Paper GSTP-HNSG describes the use of G.hn over powerline infrastructure for different smart grid use cases. The Technical Paper is intended to provide guidance to silicon vendors, system vendors and electrical utilities to define, configure and deploy devices using G.hn transceivers in smart grid environment.

NOTE – This is an informative ITU-T publication. Mandatory provisions, such as those found in ITU-T Recommendations, are outside the scope of this publication. This publication should only be referenced bibliographically in ITU-T Recommendations.

Keywords

BPL, energy, G.hn, low voltage, medium voltage, meter, smart grid.

Table of Contents

| | Page |
|---|-------------|
| 1 Scope | 1 |
| 2 Introduction | 1 |
| 3 References..... | 1 |
| 4 Definitions | 2 |
| 5 Abbreviations and acronyms | 2 |
| 6 Smart grid infrastructure..... | 4 |
| 6.1 LV distribution network | 6 |
| 6.2 MV distribution network | 12 |
| 7 Use cases..... | 21 |
| 7.1 Use case 1: Smart meter | 21 |
| 7.2 Use case 2: Smart meter GW..... | 22 |
| 7.3 Use case 3: narrow-band smart meters concentrator | 33 |
| 7.4 Use case 4: MV backbone | 35 |
| 8 Coexistence and interoperability | 38 |
| 8.1 Coexistence between G.hn smart grid system and PLC in- home systems.... | 38 |
| 8.2 Interoperability between different G.hn smart grid vendors | 38 |
| 9 Telecommunication infrastructure based on G.hn technology | 39 |
| 9.1 BPL network node types | 39 |
| 9.2 Tree topology..... | 40 |
| 9.3 Definitions for logical topology from powerline communication perspective..... | 40 |
| 9.4 Other considerations on MV electrical topologies | 41 |
| 10 Implementation of use cases with G.hn technology | 41 |
| 10.1 Use case 1: Smart meter | 41 |
| 10.2 Use case 2: Smart meter GW..... | 42 |
| 10.3 Use case 3: narrow-band Smart meters concentrator | 44 |
| 10.4 Use case 4: MV backbone | 44 |
| Appendix I..... | 45 |
| I.1 WAN use cases (WUCs) | 47 |

Technical Paper ITU-T GSTP-HNSG

Technical Paper on the use of G.hn technology for smart grid

1 Scope

This Technical Paper describes the use of G.hn transceivers over powerline infrastructure for different smart grid use cases. The document is intended to provide guidance to silicon vendors, system vendors and electrical utilities to define, configure and deploy devices using G.hn transceivers in this type of environment.

This Technical Paper does not enter into the details of G.hn technologies as they are already described in the relevant ITU-T Recommendations. The G.hn family of Recommendations includes [ITU-T G.9960], [ITU-T G.9961], [ITU-T G.9962], [ITU-T G.9963] and [ITU-T G.9964] and is referred to herein as ITU-T G.996x.

2 Introduction

This Technical Paper describes the use of ITU-T G.996x transceivers over powerline infrastructure for different smart grid use cases.

The Technical Paper provides guidance to silicon vendors, system vendors and electrical utilities to define, configure and deploy devices using ITU-T G.996x transceivers in this type of environment.

This Technical Paper also provides rules that may be used for the design of a smart grid network.

- **Clause 6** provides a brief overview of the smart grid infrastructure (for both low voltage (LV) and medium voltage (MV)), including usual topologies and channel characteristics.
- **Clause 7** describes several possible use cases where G.hn technology may be applied in the context of smart grid.
- **Clause 8** studies the behaviour of smart grid systems based on ITU-T G.hn technology in scenarios of coexistence with networks operated by different electrical utilities.
- **Clause 10** explains how to address the use cases proposed in previous clauses by using devices compliant with ITU-T G.996x Recommendations. The clause includes guidelines on how to configure and deploy such devices for each of the specific use cases.

3 References

- | | |
|----------------|--|
| [ITU-T G.9960] | Recommendation ITU-T G.9960 (2018), <i>Unified high-speed wire-line based home networking transceivers – System architecture and physical layer specification.</i> |
| [ITU-T G.9961] | Recommendation ITU-T G.9961 (2018), <i>Unified high-speed wire-line based home networking transceivers – Data link layer specification.</i> |
| [ITU-T G.9962] | Recommendation ITU-T G.9962 (2018), <i>Unified high-speed wire-line based home networking transceivers – management specification.</i> |
| [ITU-T G.9963] | Recommendation ITU-T G.9963 (2018), <i>Unified high-speed wireline-based home networking transceivers - Multiple input/multiple output specification.</i> |
| [ITU-T G.9964] | Recommendation ITU-T G.9964 (2011), <i>Unified high-speed wireline-based home networking transceivers – Power Spectral Density specification.</i> |

- [Dominiak, 2012] Dominiak, S., Andersson, L., Maurer, M., Sendin, A., Berganza, I. Proceedings of the 6th WorkShop on Power Line Communications, (2012), *Challenges of broadband PLC for medium voltage smart grid applications*.
- [Sendin, 2014] A Sendin, J Simon, I Urrutia, I Berganza. 18th IEEE International Symposium on Power Line Communications and its Applications (2014), *PLC deployment and architecture for Smart Grid applications in Iberdrola*.
- [Sendin, 2016] Sendin, A., Sanchez-Fornié, M. A., Berganza, I., Simon, J., Urrutia I. Artech House, (2016), *Telecommunication Networks for the Smart Grid*.

4 Definitions

This Technical Paper defines the following terms:

4.1 electrical topology: The infrastructure electrical connectivity of the different elements of the power line infrastructure over which a telecommunications network is built.

4.2 logical topology: The structure showing the possibility of establishing logical connections (i.e., the formation of a node with the ability to communicate higher layer information to another node).

4.3 physical topology: Describing the possibility Structure demonstrating the establishment of physical connections (i.e., the ability by a node to decode PHY frames from another node) between nodes of a powerline network built on top of the grid infrastructure.

4.4 smart grid: A digital technology that allows for two-way communication between the utility and the different devices that compose the electrical grid for the purposes of managing, control and monitor the status of the network.

4.5 ITU-T G.996x node: A transceiver implementing ITU-T G.996x family of Recommendations.

5 Abbreviations and acronyms

This Technical Paper uses the following abbreviations and acronyms:

| | |
|-------|--|
| AAAC | All Aluminium Alloy Conductor |
| AAC | All Aluminium Conductor |
| ACAR | Aluminium Conductor Aluminium-Alloy Reinforced |
| ACSR | Aluminium Conductor Steel Reinforced |
| AMI | Automatic Meter Infrastructure |
| BPL | Broadband Power Line |
| DA | Digital Automation |
| DM | Domain Master |
| DNO | Distribution Network Operator |
| DSO | Distribution System Operator |
| EMC | Electromagnetic compatibility |
| E-LAN | Ethernet Local Area Network |

| | |
|---------|---|
| EPR | Ethylene-Propylene Rubber |
| GIS | Geographical Information System |
| GW | Gateway |
| HAN | Home Area Network |
| HE | Head End |
| HV | High Voltage |
| IACS | International Annealed Copper Standard |
| IEEE | Institute of Electrical and Electronics Engineers |
| ISM | Industrial, Scientific and Medical |
| IP | Internet Protocol |
| LAN | Local Area Network |
| LLDPE | Linear Low-Density PolyEthylene |
| LMN | Local Metering Network |
| LV | Low Voltage |
| MAC | Medium Access Control |
| MDM | Meter Data Management |
| MO | Metering Operator |
| MV | Medium Voltage |
| NB-PLC | Narrowband PLC |
| PCP | Priority Code Point |
| PE | Polyethylene |
| PILC | Paper Insulated Lead Covered |
| PLC | Powerline Communication |
| PS | Primary Substation |
| PVC | Polyvinyl Chloride |
| RADIUS | Remote Authentication Dial-In User Service |
| SG | Smart Grid |
| SG-HE | Smart Grid Head End |
| SM | Smart Meter |
| SS | Secondary Substation |
| SMGW | Smart Meter Gateway |
| SNR | Signal to Noise Ratio |
| TCP | Transmission Control Protocol |
| TLS | Transport Layer Security |
| TR-XLPE | Tree-Retardant Cross-Linked Polyethylene |
| UART | Universal Asynchronous Receiver-Transmitter |
| UDP | User Datagram Protocol |

| | |
|------|---------------------------|
| VLAN | Virtual LAN |
| WAN | Wide Area Network |
| xDSL | X Digital Subscriber Loop |
| XLPE | Cross-linked polyethylene |

6 Smart grid infrastructure

The electricity networks are made up for three stages: generation, transport, and distribution.

- 1) **Generation:** The power plants convert the energy stored in the fuel (coal, oil, gas, nuclear) or renewable energies (hydro, wind, solar, etc.) into electric energy.
- 2) **Transport:** This electricity flows to a transformer to change a large current and low voltage into a small current and high voltage in order to reduce energy transportation losses.
- 3) **Distribution:** In this stage, the electricity flows over high voltage transmission lines to a series of transformer substations where the voltage is stepped down by transformers to levels appropriate for distribution to customers (120 – 480 V).

In the distribution network, transformer substations are differentiated in two types: primary substations (where the voltage level is transformed from high to medium) and secondary substations (where the voltage level is transformed from medium to low). As a result, two voltage levels are found in the distribution network:

- i) **Medium voltage network (4 – 35 kV):** serves to interconnect a primary substation (HV/MV) with different secondary substations (MV/LV) and, depending on the topology, with another primary substation.
- ii) **Low voltage network (<1 kV):** is used for the delivery of the electricity from the secondary substation to the final customers.

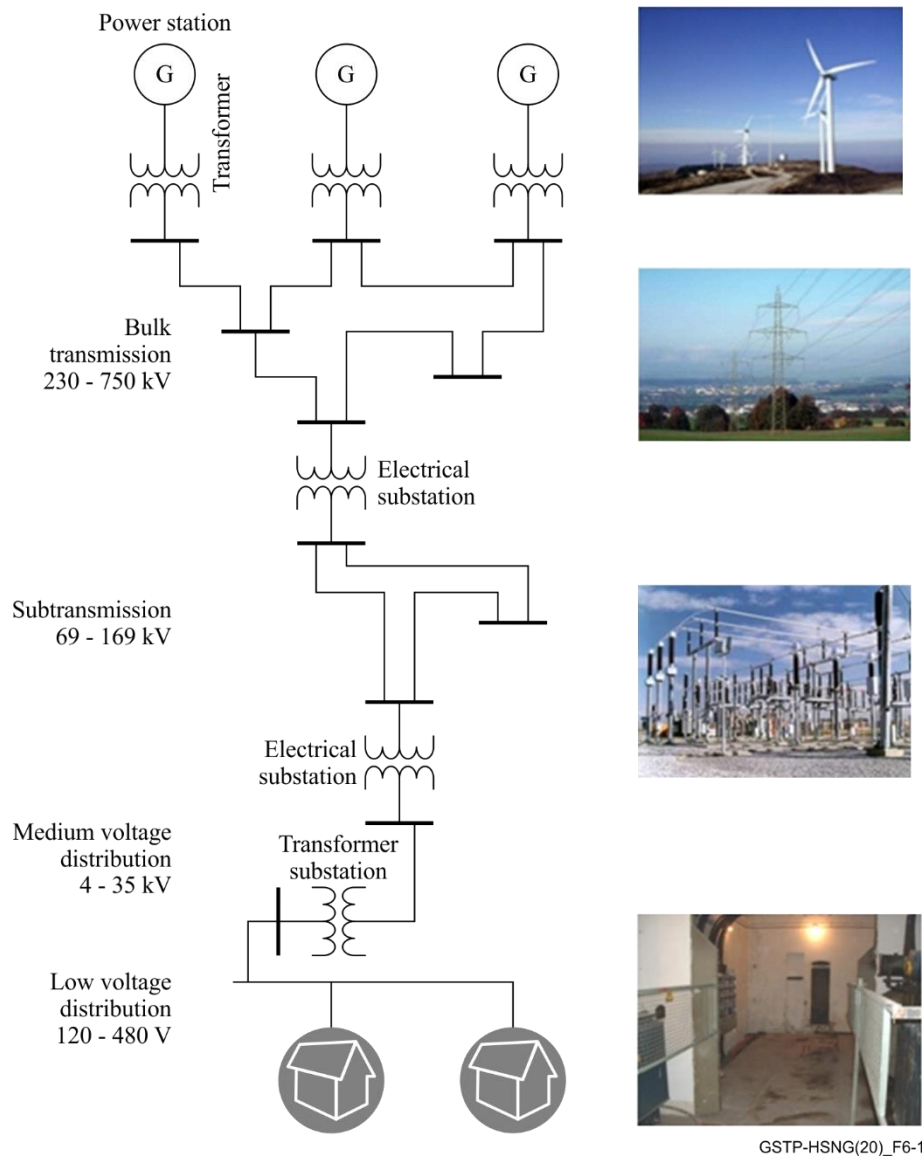

Figure 6-1 – Overview of electric energy system

The voltages shown in Figure 6-1 are only illustrative. They can slightly change depending on the national regulations and the internal procedures of each power utility.

Figure 6-2 shows a general electrical scheme of a transformer substation:

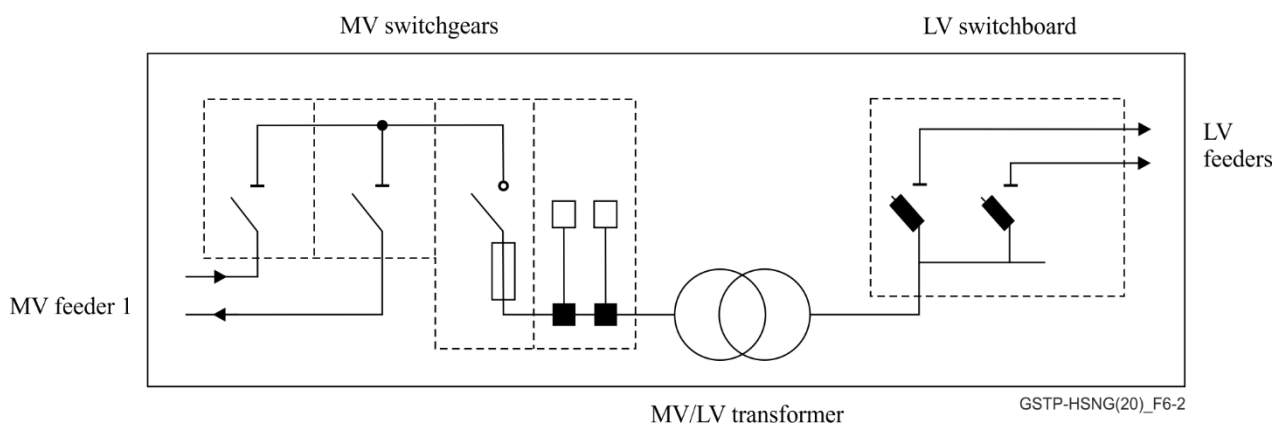

Figure 6-2 – Secondary substation diagram

Clause 6-1 describes the common topologies which can be found in the distribution networks.

6.1 LV distribution network

Low voltage (LV) distribution networks are built and operated in different topologies. However, in general there are two different topologies that need to be considered:

- Meshed networks,
- Tree networks.

6.1.1 Topologies

For a basic understanding of LV topologies, it has to be considered that the electrical topology is not necessarily identical with the physical or logical topology from a powerline communication perspective.

This clause describes the electrical topologies of the LV network. The mapping of these electrical topologies to physical/logical topologies using G.hn connectivity is described in clause 9.

Figure 6-3 is the legend for topology Figures 6-3, 6-4, 6-5, 6-6, 6-7 and 6-8.

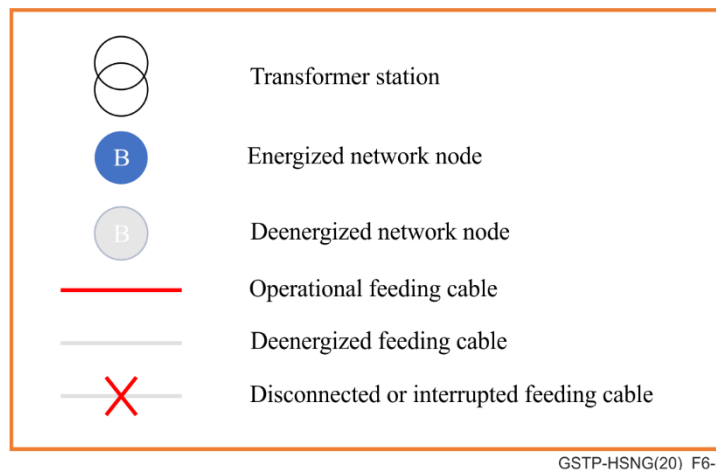

Figure 6-3 – Legend for topology figures

6.1.1.1 LV tree

The typical LV tree topology shows the following schematic:

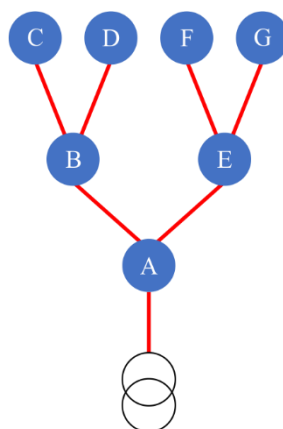
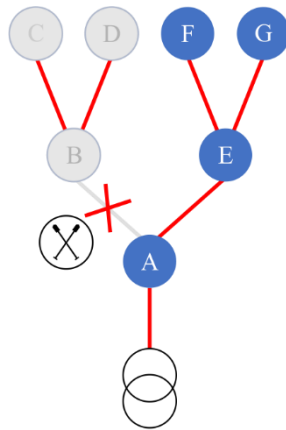

Figure 6-4 – Typical LV tree topology

The main characteristic of an LV tree topology is the lack of any redundancy:

- The interruption of any feeding cable (in this example A-B) leads to de-energizing of the following infrastructure (in this example B, C, and D) in the tree:



GSTP-HSNG(20)_F6-5

Figure 6-5 – Interruption of a feeding cable in an LV tree topology

6.1.1.2 LV mesh

By adding redundant feeding cables to an LV tree topology, a meshed LV mesh topology will be achieved.

The typical meshed LV mesh topology is shown in Figure 6-6.

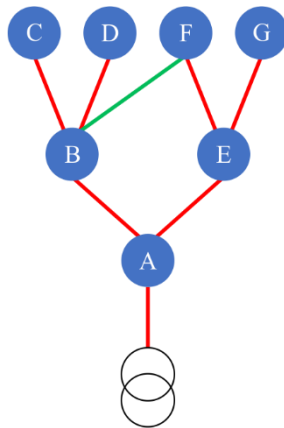

GSTP-HSNG(20)_F6-6

Figure 6-6 – Typical LV mesh topology

The main characteristic of an LV mesh topology is the presence of redundancy.

The interruption of a feeding cable (in this example A-B) does not necessarily lead to de-energizing of parts of the electrical network:

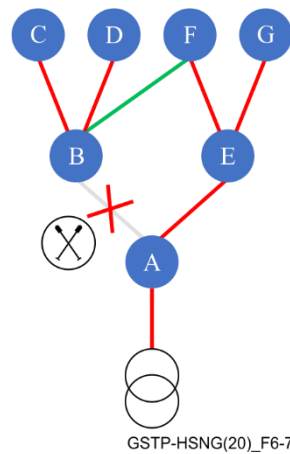

Figure 6-7 – Interruption of a feeding cable in a meshed LV topology

Redundancy is a very desirable property of the LV mesh topology; ideally it allows both maintenance of feeding cables and repair on damaged feeding cables with no de-energizing parts of the electrical network except the feeding cable in focus.

On the backside of the LV mesh topology, the current load of every single feeding cable becomes somewhat hardly predictable and – in case of multiple transformer stations – the load on every transformer is not necessarily within the desired range.

Consequently, in many cases the LV mesh topology is operated as an LV tree topology by (single-ended) disconnecting (redundant) feeding lines and/or feeding lines to redundant transformer stations, e.g., by removing fuses. The redundant properties of an LV mesh topology become available on-demand while feeding line current loads and transformer loads are well predictable.

6.1.1.3 LV tree topology from a powerline communication perspective

A typical LV physical tree topology is shown Figure 6-8.

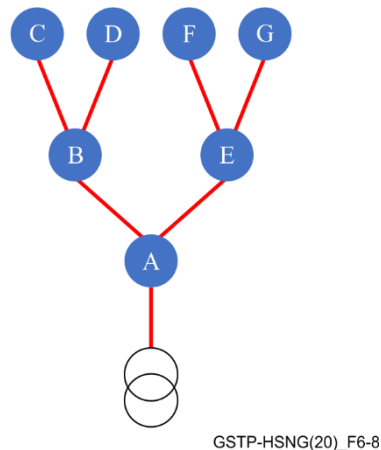

Figure 6-8 – LV physical tree topology

This can be abstracted in a logical-matrix using nodes, which are capable of repeating:

Boolean Expression:

$$r_{AT}=AT$$

$$r_{BT}=AT*AB$$

$$r_{CT}=AT*AB*BC$$

$$r_{DT}=A_T * A_B * B_D$$

$$r_{ET}=A_T * A_E$$

$$r_{FT}=A_T * A_E * E_F$$

$$r_{GT}=A_T * A_E * E_G$$

The main characteristic of a physical tree topology is the lack of any redundancy, which is expressed in the Boolean expression of exactly one possible route.

Example:

C will have a route to the transformer station T (r_{CT}) if link AT and link AB and link BC are working as desired. In case that one single link fails there will be no route r_{CT} .

6.1.2 Channel characteristics

LV lines are basically divided into overhead and underground. However, materials and dimensions differ greatly for various types of cables, even more than in medium voltage (MV).

LV overhead lines use either bare conductors supported on glass/ceramic insulators or an aerial bundled cable system. Both bare conductors and bundled cables can actually be laid outdoor on poles or wall-mounted. Conducting material is usually either aluminium or copper (the former is preferred).

Medium to large-sized towns and cities have underground cable distribution systems. These also show a typical structure of conductor that is insulated with the same materials discussed for MV and is protected by an outer polyvinyl chloride (PVC) jacket. Underground cables can be found inside utility tunnels, laid in ducts or tubes, or directly buried in trenches.

6.1.2.1 Channel characteristics for underground cabling

The channel characteristics of LV distribution networks are different from in-home channels due to the greater length of the links and, in many cases, due to the topology.

Generally, two electrical components contribute most to the channel characteristics:

- LV-cable links,
- LV-cable joints and distributions.

6.1.2.1.1 Simplified transfer functions of LV-cable links

Typical LV-cables are not shielded: cable and environmental conditions like the surrounding ground conductivity, conductor type, conductor cross-section, the type and age of the cable insulation, etc., matters. Therefore, it does not make sense to approach with absolute precision by a tenth of a dB – which would be perfectly possible if all conditions are precisely known– but instead with a raw estimation with about 1...3 dB of precision.

The typically up to 400 m long cable distances are leading to a low-pass channel characteristic which make usually higher frequencies above 15 MHz not usable.

In the 0.4 kV voltage level cable distances above 400 m are considered as not economically viable. With this distance, a broadband powerline (BPL) link is usually operable with frequencies below 15 MHz.

For exceptional long cable distances of up to 600 m used exceptionally in rural areas frequencies below 8 MHz are operable.

The simplified transfer function of a typical LV-cable depends strongly in the cable length: the longer the cable, the stronger the low-pass function and the less likely it is to receive sufficient signal strength at the reception point for higher frequencies.

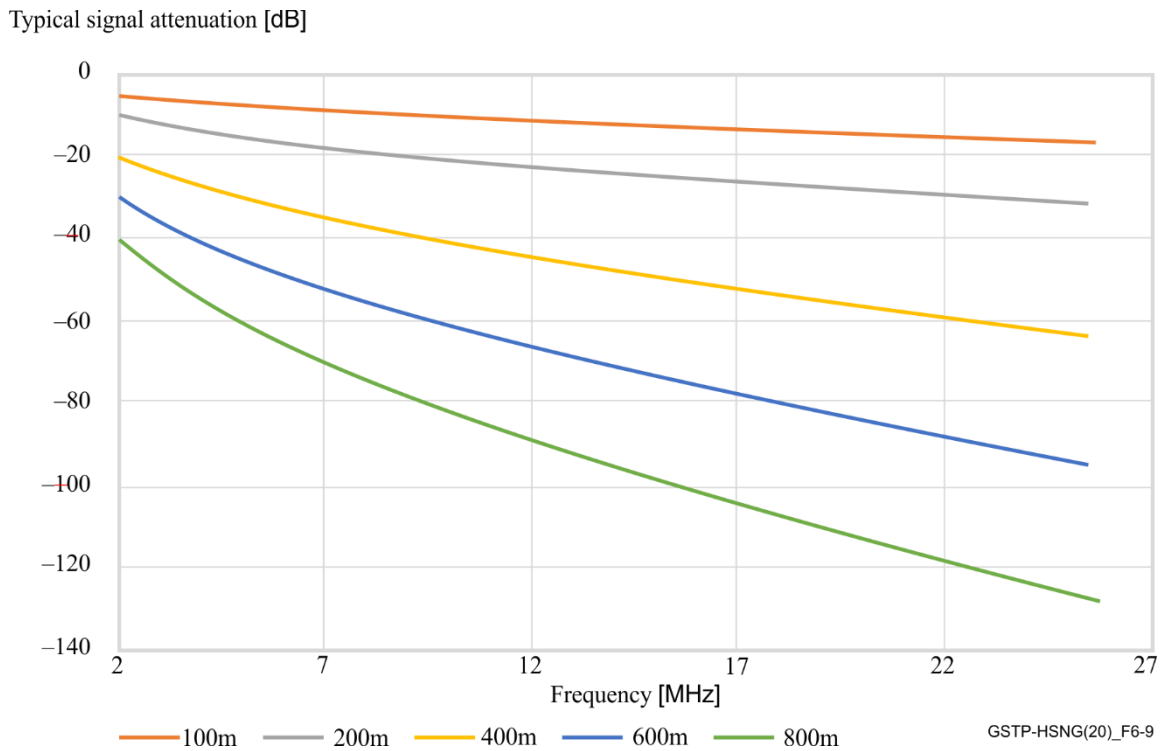

Figure 6-9 – Typical signal attenuation as function of frequency

6.1.2.1.2 Effect of cable joints and distributions

The local impedance of a distribution varies from (roughly) 80 Ohm to less than 4 Ohm for the lower end of the powerline frequency spectrum and increases with the frequency.

Any node must be able to feed this impedance spectrum linearly by the nodes output stage.

Distributions and cable joints are points where signal distribution takes place. In a first approximation, this signal distribution is independent of the usable signal frequency range due to the relatively small sizes of distributions relative to the electrical signal wavelength on cables.

The incoming signal energy will be distributed to different cable paths, whereas only one is contributing to the received signal strength of a specific link.

Whenever the cable distances between cable joints or distribution are roughly longer than 30 m, with no significant failure the contribution to the link signal losses can be estimated as:

$$A[\text{dB}] \approx 10 \cdot \log(1/(N-1)) \quad \text{where } N \text{ is the total number of cables attached to the distribution.}$$

Table 6-1 shows the attenuation versus the total number of cables attached to the distribution.

Table 6-1 – Attenuation vs total number of cables attached to the distribution

| N = | A[dB] ≈ | N = | A[dB] ≈ |
|------------------|---------|-----|---------|
| 3 (Cable Joints) | 3 | 8 | 8 |
| 4 | 5 | 9 | 9 |
| 5 | 6 | 10 | 10 |
| 6 | 7 | 15 | 11 |
| 7 | 8 | 20 | 13 |

The simplifications done to calculate these values do not recognize the fine effects caused by impedance mismatch between cable and local impedance of distributions.

LV Cables are recognized as strongly attenuated, which keeps the effect of reflections and therefore a ripple in the line attenuation relatively low. In powerline communication through LV networks, the ripple is barely noticeable but of course, present.

As an example of the effect of reflections, a ripple caused by impedance mismatch for a link between a distribution of 10 outgoing lines and another distribution of 7 outgoing lines, connected via a 200 m long LV-cable with a typical impedance of 80 Ohm is less than 1dB.

6.1.2.1.3 Local noise level

Local noise level is the most unpredictable parameter in an LV distribution network.

Generally, the local noise level is only important at the reception point. To be decoded, the received signal amplitude of a specific carrier must be higher than the noise level.

From powerline communication perspective, in a link both nodes transmissions have to be decoded at both sides of the link.

Very often, the local noise level at both ends of a link differs and therefore very often an asymmetrical link performance is achieved.

The most significant sources for high local noise level are photovoltaic converters by far. In case of the presence of such equipment the local noise levels will not be constant over time because of the changes of meteorological conditions (e.g., sunny day, rainy day, after sunset).

Besides those strong nearby noise sources, there is a basic noise floor, which is the contribution by various household devices, power supplies, electrical lights, communication technologies, etc.

For instance, at night, short wave broadcast stations in the broadcast bands deliver a small, but still significant signal level, which is from powerline perspective equivalent to noise. This effect happens also in the opposite direction. The signal level contribution of broadcast stations can efficiently be suppressed with common mode chokes, integrated in the analogue frontend of a node, due to their common-mode character. The secondary effect or – depending on the point of view – primary effect of this common-mode suppressing frontend feature is, that this also reduces the radiation of powerline signals from an unshielded LV-cable, which improves the coexistence level of both communication technologies.

Figure 6-10 shows some examples of local noise levels scaled in dBmW (Resolution Bandwidth 300 kHz, Peak Hold).

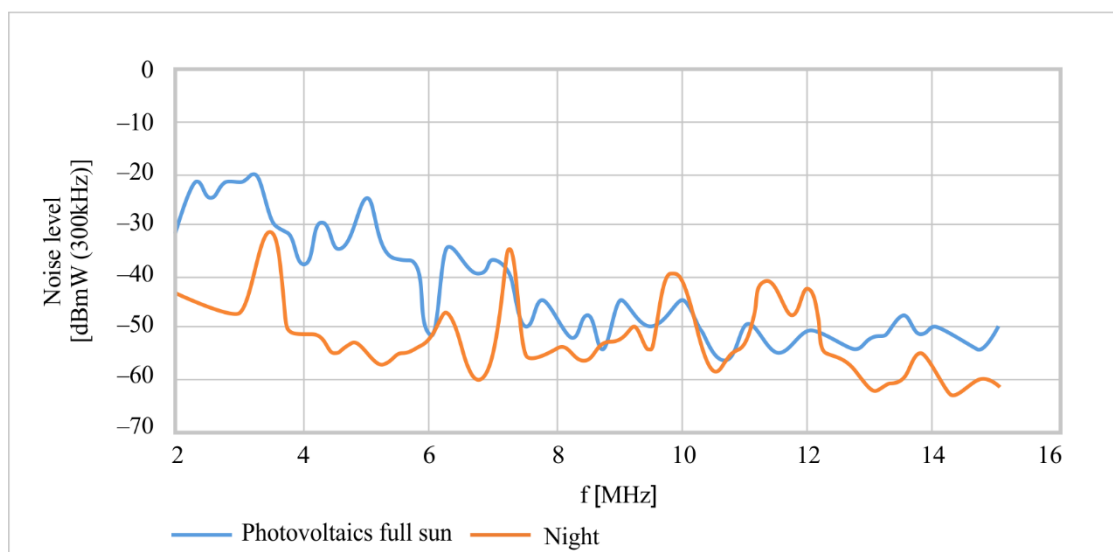

GSTP-HSNG(20)_F6-10

Figure 6-10 – Examples of noise levels

6.1.2.2 Channel characteristics for overhead cabling

For further study.

6.2 MV distribution network

6.2.1 Topologies

The medium voltage networks can transport the energy in a structure of double or single circuit. Figure 6-11 shows the structure of a double circuit.

- **Double circuit or double derivation** consists in two lines for each phase, one of them acts as the service line and the other acts as a backup line. It allows avoiding the overload of the lines and better responses to possible failures. This topology only exists in high density areas or with special requirements. The average number of MV/LV transformers on the MV cable is 20, but it may vary from 4 to 30. The distance between two MV/LV transformers on the MV cable can be from 150 to 400 m.

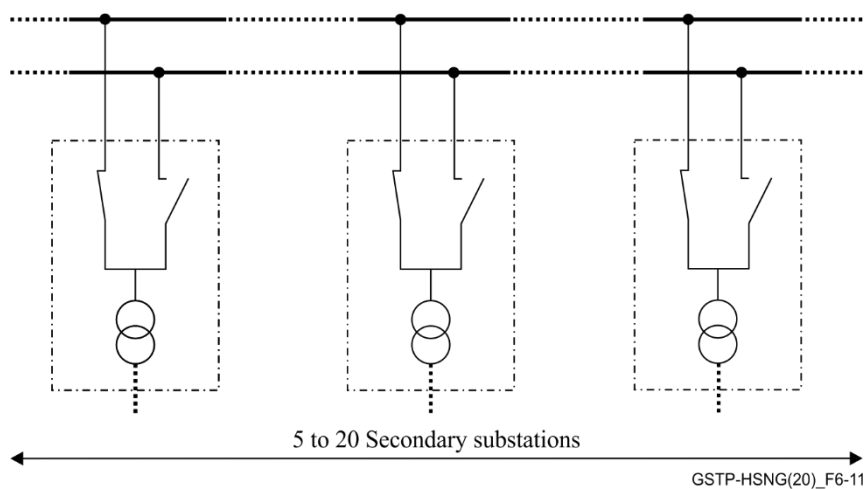

Figure 6-11 – Structure of double circuit

- **Single circuit** consists in one line for each phase. The average number of MV/LV transformers on the MV cable is 20, but it may vary from 4 to 30. The distance between two MV/LV transformers on the MV cable can be from 150 to 700 m. In low density areas, the distance between substations is longer and can be up to few (from 1 to 10) kilometres. Figure 6-12 shows the structure of a single circuit.

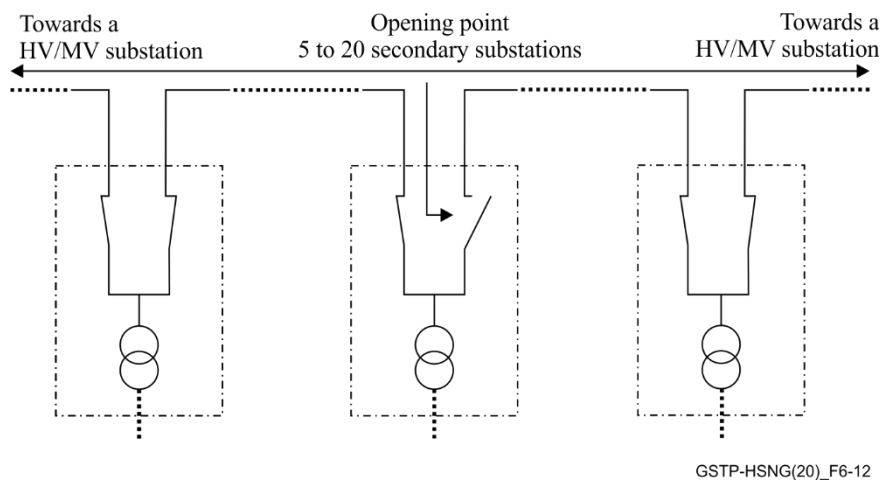

Figure 6-12 – Structure of single circuit

There are three electrical topologies to deliver electricity through the MV grid: radial, ring or networked.

6.2.1.1 MV radial electrical topologies

This topology joins the primary substations (PS) (HV/MV) with the secondary substations (SS) (MV/LV) by means of radial lines. These lines (or feeders) can be exclusive for one secondary substation or cross several secondary substations. Figures 6-13, 6-14 and 6-15 give examples of radial electrical topologies.

An advantage of the radial system by means of exclusive MV lines is the centralised control of all the secondary substations from the primary substation.

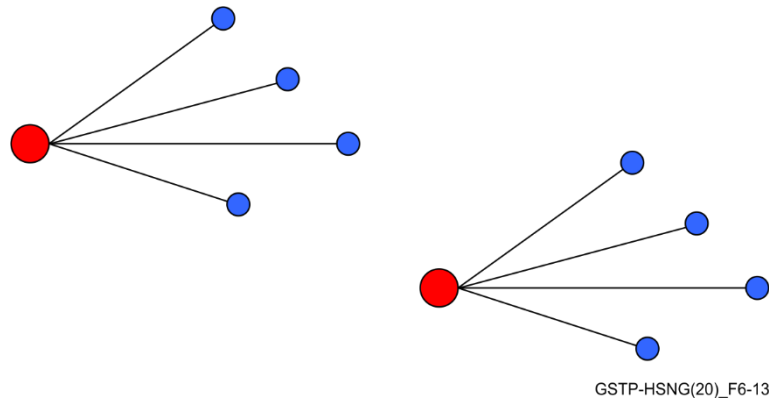

Figure 6-13 – Radial topology. Exclusive MV lines. PS in red, SS in blue

The structure of a MV line which feeds several secondary substations, passing one by one is very common. This system requires distributed control devices (e.g. switchgears), one for each secondary substation.

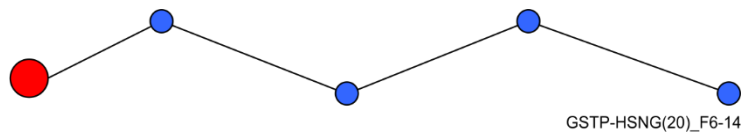

Figure 6-14 – Radial topology. Single MV line. PS in red, SS in blue

Both systems are quite intuitive. It implies a simpler design of the network. The tree-shaped topology is a mixed between the other two previous ones. The line comes from the electrical substation and divides into branches and more branches until it reaches the secondary substations.

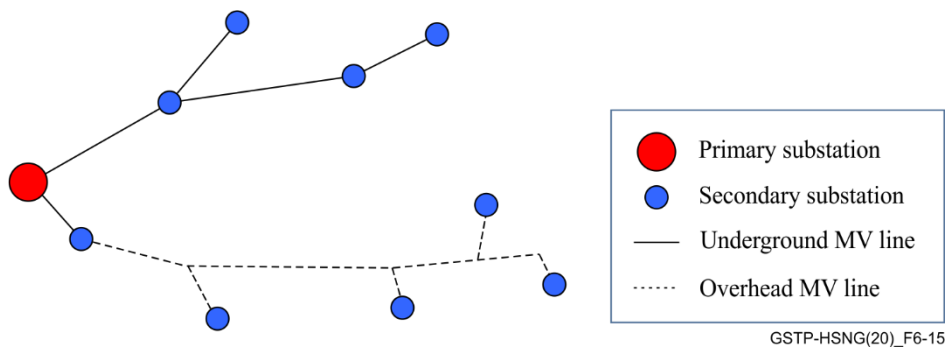

Figure 6-15 – Radial topology. Tree-shaped line. PS in red, SS in blue

In rural areas, it is common to find overhead MV grid which typically has a radial topology. But, unlike underground grid, we can find branches in overhead lines without MV switchgears in the derivation. This means that in underground MV grid point-to-point MV feeders are found, whereas in overhead MV grid point-to-multipoint MV feeders are found.

Radial topologies have many advantages over networked topologies including:

- Easier fault current protection,
- Lower fault currents over most of the circuit,
- Easier voltage control,
- Easier prediction and control of power flows,
- Lower cost.

6.2.1.2 MV ring electrical topologies

Ring topologies appear to overcome a weakness of the radial topologies. As the loss of one stretch of the MV line means interrupting the energy after the stretch, not feeding its correspondent secondary substations.

Therefore, the ring topology can be seen as an improved radial topology providing open tie points to other MV lines, that is to say, creating a redundancy. These lines are still operated radially, but if a fault occurs on one of the stretches, the tie switches allow some portion of the faulted line to be restored quickly. Normally, these switches may be manually operated, or automatically with the use of automated (and remote-controlled) switches.

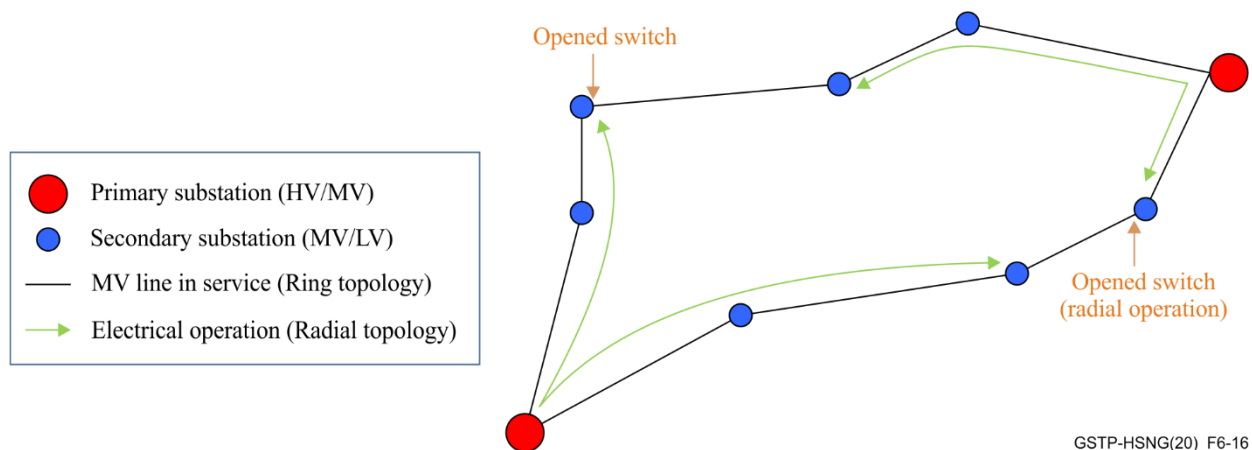

Figure 6-16 – Ring topology. PS in red, SS in blue

MV BPL couplers should inject the BPL signal to the feeder before the switchgears. This way, the position of the MV switches is not relevant for BPL communication, as they are physically bypassed from one MV feeder to another MV feeder, independently of the switch position. The position of the switch (closed, opened, grounded) may affect the BPL transfer function.

6.2.1.3 MV meshed electrical topologies

A meshed networked topology is a network in which the primary substations and the secondary substations are joined through many MV lines in a mesh. Therefore, the power can be delivered by several routes. If a line is removed from the service, power can be rerouted.

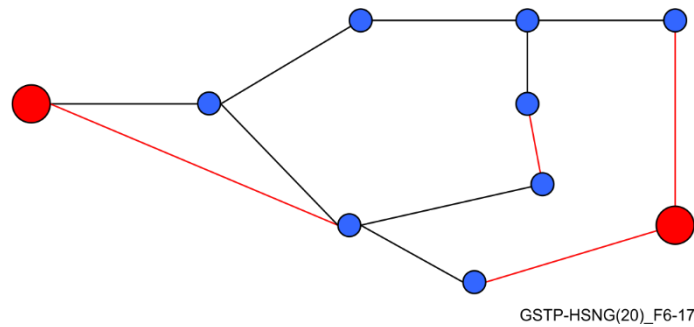

Figure 6-17 – Meshed topology. PS in red, SS in blue

These networks are more complex. Their design requires calculation of the network behaviour in any possible condition and configuration.

6.2.2 Channel characteristics

6.2.2.1 MV channel conditions

The medium voltage lines are the elements which carry the electrical power in the medium voltage distribution. The cable must be selected to safely provide adequate electrical power with continuous, trouble-free operation in a system which is able to withstand unexpected demands and overload conditions. The MV grid can use either overhead MV lines, underground lines or a mix of overhead and underground lines.

6.2.2.1.1 Overhead MV lines

These lines are overhead cables which are laid over poles. These poles can be made of wood, steel, concrete or fibreglass with different configurations, such as, one circuit per pole or more than one circuit. Overhead lines are normally classified according to the conductor. Most conductors are aluminium or copper. Nowadays, utilities use aluminium for almost all new overhead installations as aluminium is lighter and less expensive for a given current-capability. However, copper was the first metal used to transmit electricity and significant copper overhead lines are still in service.

There are four major types of overhead conductors:

- **All aluminium conductor (AAC):** AAC is made up of one or more strands of 1350 alloy aluminium (99.5% pure and has a minimum conductivity of 61.0% IACS). Because of its relatively poor strength-to-weight ratio, AAC has had limited use in rural distribution because of the long spans utilised. However, AAC has seen extensive use in urban areas where spans are usually short but high conductivity is required. These conductors are also used extensively in coastal areas because it has a very high degree of corrosion resistance. Figure 6-18 shows an overhead MV line all aluminium conductor.



Figure 6-18 – Overhead MV line. All-aluminium conductor

- **Aluminium conductor steel reinforced (ACSR):** ACSR as shown in Figure 6-19 consists of a solid or stranded steel core surrounded by one or more layers of strands of 1350 aluminium. The amount of steel can vary from 6% to 40%. The principal advantage of these conductors is its high mechanical strength-to-weight ratio. It means longer spans, lesser

supports and more resistant against ice and wind loads. Figure 6-20 shows the overhead MV line basic construction of ACSR conductors.

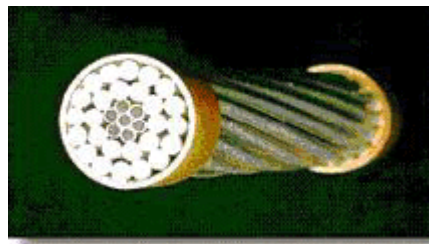

Figure 6-19 – Overhead MV line. Aluminium conductor steel reinforced

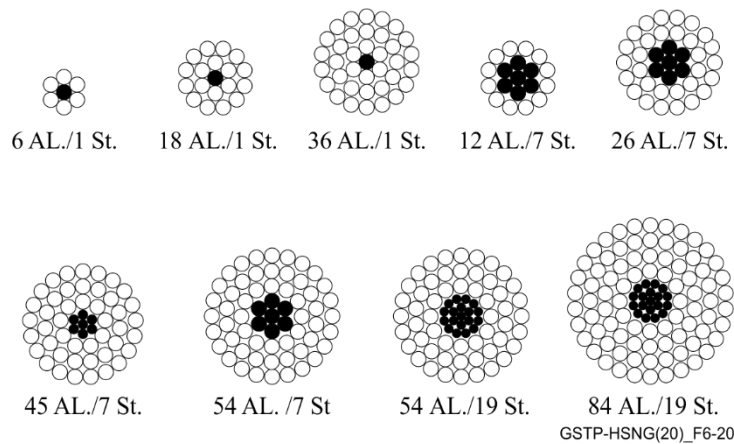

Figure 6-20 – Overhead MV line. Basic construction of ACSR conductors

- **All aluminium alloy conductor (AAAC):** AAAC as shown in Figure 6-21 is made from aluminium-magnesium-silicon alloy of high electrical conductivity containing magnesium (0.6-0.9%) and silicon (0.5-0.9%) to give it better mechanical properties after treatment. AAACs are generally made out of aluminium alloy 6201 (minimum conductivity is 54%). AAAC has a better corrosion resistance and better strength to weight ratio and improved electrical conductivity than ACSR conductor on equal diameter basis. AAAC finds good use in coastal areas where use of ACSR is prohibited because of excessive corrosion. Figures 6-2 and 6-23 show the overhead MV line basic construction of AAC and AAACs, respectively.



Figure 6-21 – Overhead MV line. All Aluminium Alloy Conductor

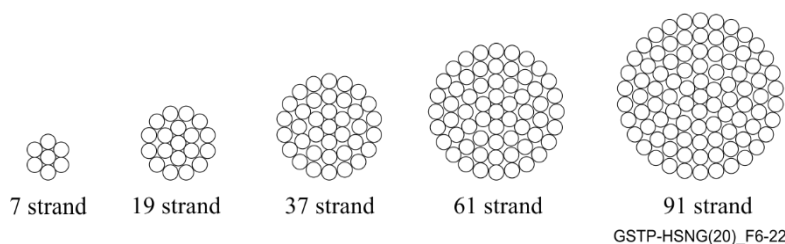

Figure 6-22 – Overhead MV line. Basic construction of AAC and AAAC conductors

- **Aluminium conductor aluminium-alloy reinforced (ACAR):** ACAR combines AAC and AAAC strands to provide a transmission conductor with an excellent balance of electrical and mechanical properties. The primary advantage of the ACAR conductor lies in the fact that all strands are interchangeable permitting the design of a conductor with an optimum balance between mechanical and electrical characteristics.

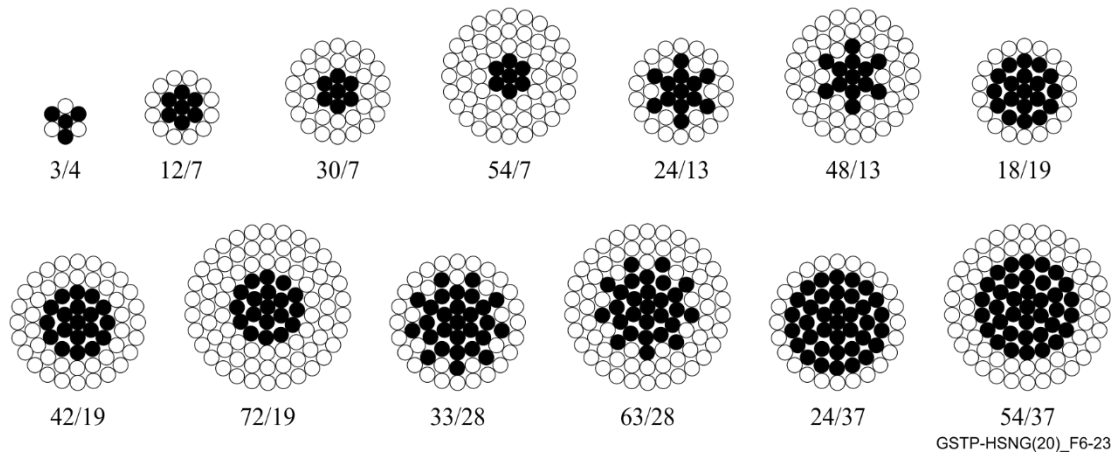

Figure 6-23 – Overhead MV line. Basic construction of AAC and AAAC conductors

For most urban and suburban applications, AAC has sufficient strength and has good thermal characteristics for a given weight. In rural areas, utilities can use smaller conductors and longer pole spans, so ACSR or another of the higher-strength conductors is more appropriate.

The wire can be insulated or not insulated. The bare (un-insulated) wire is the most common type of line used in overhead power lines. The covered wire are AAC, AAC or ACSR conductors covered with polyethylene (PE) or cross-linked polyethylene (XLPE) (see Figure 6-24). Because the lines are insulated, there is little chance of damages from vegetation or wildlife and so exhibit improved reliability.



Figure 6-24 – Overhead MV line. XLPE insulated ACSR conductor

Overhead lines show lower attenuation than underground to the transmission of the BPL signal (above 2 MHz). But on the other hand, these aerial lines are more sensitive to external interferences or noises that may be present in the air and that may be caught by the line easier than in buried lines.

Overhead MV lines are typically found in rural areas and its length might vary from several hundreds of meters to few kilometres.

6.2.2.1.2 Underground MV lines

The buried lines are the cables which are underground. Buried lines are more hidden from view, safer as there are less opportunities for accidental contact, more reliable as there are fewer short and long duration interruptions and lower maintenance cost. However, the cost is more expensive than overhead lines.

The buried lines can be commonly found in one of the following ways, and as shown in Figures 6-25 to 6-27:

- Directly buried,
- Laying in ducts,
- Laying in troughs,
- Laying inside galleries.



Figure 6-25 – Directly buried

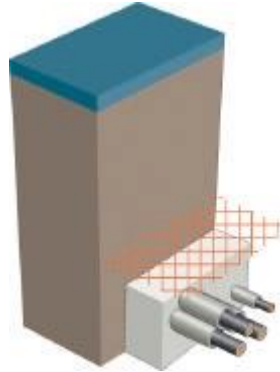

Figure 6-26 – Laying in ducts

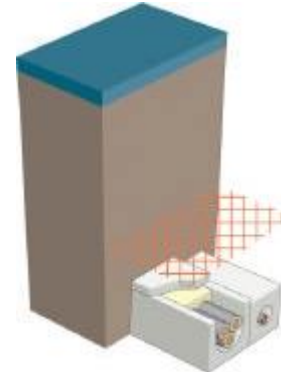

Figure 6-27 – Laying in troughs

It is not strange to find several MV lines going in parallel and very close in a trough for some meters; sometimes even MV and LV lines. This situation favours the signal induction from one line to another and must be taken into account especially when it is not a desired effect as it may introduce interferences between different BPL domains working in the same frequency band. The level of induction depends on the length of the common path, the characteristics of the cables (jacket, shield, etc.).

In general, the structure of an underground cable as shown in Figure 6-28 is made up of the following parts (from inner to outer layers): conductor, conductor shield, insulation, insulation shield, neutral or shield and jacket.

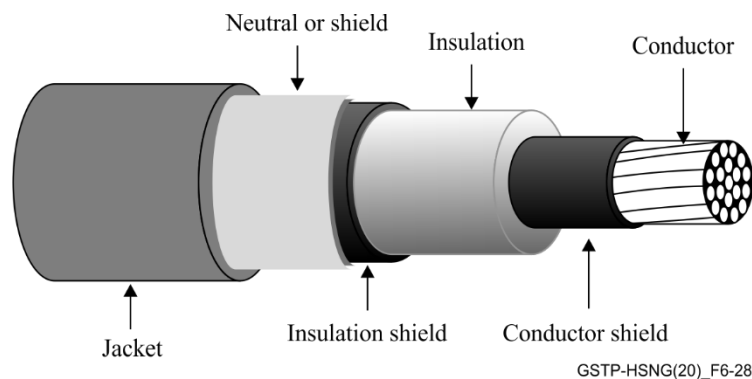
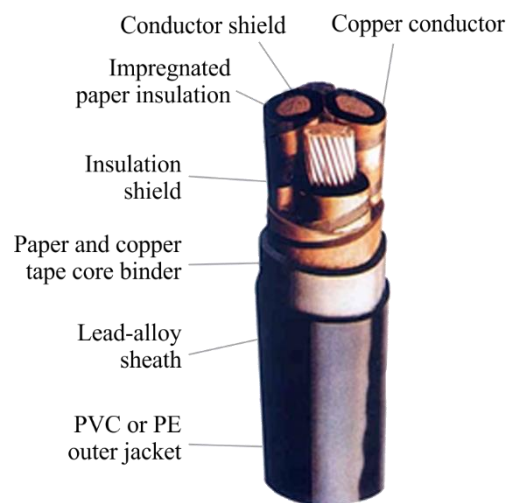

Figure 6-28 – General structure of an underground MV cable

- **Conductor:** The conductor is the current carrier of the cable. The conductors which are used in the underground cables are aluminium and copper. The conductors can be solid or stranded. Solid-conductor cables are less expensive and have better conductivity. However, stranded conductors have better flexibility and durability.
- **Conductor shield:** The conductor shield surrounds the conductor. The conductor shield provides for a smooth, radial electric field within the insulation. Without this shield, the electric field gradient would concentrate at the closest interfaces between the conductor and

the insulation; the increased localised stress could break down the insulation. These shields are made by adding carbon to a normally insulating polymer like ethylene-propylene rubber (EPR), polyethylene (PE) or cross-linked polyethylene (XLPE).

- **Insulation:** The insulation holds back the electrons. It means that the insulation allows cables with a small overall diameter to support a conductor at significant voltage. The key parameters of cable insulation are: dielectric constant, volume resistivity, dielectric losses and dissipation factor. According to the insulation, the cables can be:
- **Paper insulated lead covered (PILC):** Paper-insulated cables have provided reliable underground power delivery for decades. PILC cables have kraft-paper tapes wound around the conductor which are dried and impregnated with insulating oil. A lead covering is extruded over the core and then a protective jacket is extruded over the lead shield. This type of cables is considered "old" cables. See Figure 6-29 for an example of a PILC cable.



GSTP-HSNG(20)_F6-29

Figure 6-29 – PILC cable

- **Synthetic insulated cable:** Different materials may be used as insulator such as PVC, PE XLPE, tree-retardant cross-linked polyethylene (TR-XLPE), ethylene-propylene rubber (EPR). These synthetic insulations are tough, inexpensive and have good electrical properties.



Figure 6-30 – XLPE cable

- **Insulation shield:** The insulation shield surrounds the insulation. As conductor shield, the insulation shield evens out the electric field at the interface between the insulation and the neutral/shield. Without this shield, the electric field gradient would concentrate at the closest interfaces between the insulation and the neutral or shield; the increased localised stress could break down the insulation. One important aspect of the insulation shield is its "strip-ability". The insulation shield must be easily strippable in order to be terminated and spliced.

These shields are made by adding carbon to a normally insulating polymer like EPR or PE) or XLPE. Figure 6-30 shows an example of an XLPE cable.

- **Neutral or shield (sheath):** The shield is the metallic barrier which surrounds the cable insulation. The neutral or shield holds the outside of the cable at (or near) ground potential. It also provides a path for return current and for fault current. The shield also protects the cable from lightning strikes and from current from other fault sources. The shield can be constructed with wires or tapes. The first type, which is used in cables known as concentric neutral cables, are able to carry unbalanced current. The second type, which is used in cables known as power cables, shows a higher resistance. The copper is the conductor used as the aluminium corrodes too quickly to perform well in this function. Figures 6-31 and 6-32 show the types of concentric neutral cables.

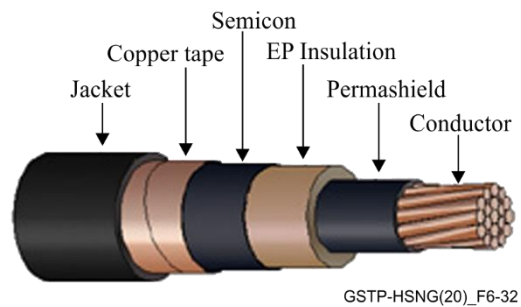
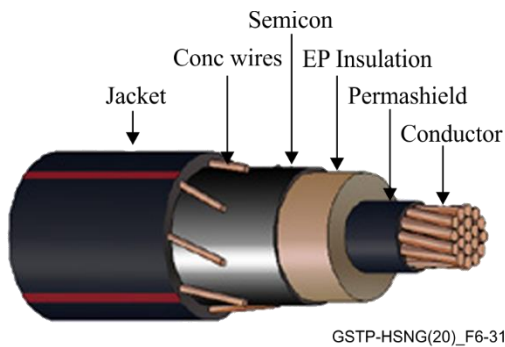

Figure 6-31 – Concentric neutral cable

Figure 6-32 – Concentric neutral cable

- **Jacket:** A cable jacket is the outer covering which surrounds a cable's core, shields and insulation. Its purpose is to protect these components from mechanical damage, chemicals, moisture and exposure to harmful environmental conditions. Most jackets are made of extrudable plastics. PVC was one of the earliest jacketing materials and is still common. The most common jacket material is currently made from linear low-density polyethylene (LLDPE).

The underground cables can be divided into two types as shown in Figures 6-33 and 6-34: single-core cable or three-core cable (each core with its own insulation and shield). In addition, all these cables can have armoured layers over the insulation to provide the cable with mechanical protection.



Figure 6-33 – Single-core cable



Figure 6-34 – Three-core cable

Underground MV lines are typically found in urban areas and its length does not usually exceed 700 metres (and hardly ever more than one kilometre).

6.2.2.1.3 Splices

The splices are joins between two pieces of cable in order to repair the damaged part of the cable forming one piece again or in order to extend the length of the cable. Each piece of cable is called a segment.

As a result, there can be (one segment), one (two segments) or even several joins in a MV line between two secondary substations. Each join presents additional attenuation to the transmission of the BPL signal; this attenuation depends on the different types of cables that have been joined, the quality of the join process, etc.

Because of the joins or splices, segments of different MV types of cables are found in a MV line, from one secondary substation to another. When this mixture is present, it is referred to as "mixed cables": overhead-underground, aluminium-lead, etc.

6.2.2.2 MV channel characteristics

Typical channel characteristics might be provided in a future release of this Technical Paper.

7 Use cases

7.1 Use case 1: Smart meter

7.1.1 Use case description

The usage of BPL communication in smart meters is already starting and getting traction in different markets all over Europe. In this application, a communication module is directly integrated into a smart meter (SM) to provide connectivity and communications capabilities. The main function is to read the metering data, but also remote-control functions, like shutting down/limiting the power supply are realised. The BPL network can also be used to provide meter reading information to the end-customer.

In this use case, the BPL device will typically have some type of serial interfaces to connect to the meters. To read data from water and gas meters, wireless M-Bus is widely used in Europe and North Africa. To read data from electrical meters RS-485/UART is widely used in Europe and North Africa. The BPL device may receive data from one or more meters (typically maximum of 32 meters for RS-485 interfaces).

Meter data is managed by a meter data management (MDM) backend application system. There are two types of meter reading protocols used by an MDM: (1) a push protocol sending data from the meter to the MDM and (2) request/response protocol from the MDM to the meter, requesting data from one or more meters. Both protocols encapsulate the serial protocol in user datagram protocol (UDP) or transmission control protocol (TCP). The request/response protocol is used for: reading data from the meter and remote-control functions.

7.1.2 Use case guidelines

7.1.2.1 Number of active nodes

In full rollout scenarios a large number of meters (up to approximately 1000) will be connected to the network, resulting in a high penetration of networks.

7.1.2.2 Latency

The number of "active" nodes (i.e., modems) depends on the protocol and the MDM configuration. The push protocol has meter data typically being pushed a few times a day (as configured by the MDM). Using the request/response protocol, the MDM is often configured to send several requests in parallel.

The latency needed using the push protocol logically should be five to ten seconds to ensure reasonable timestamping on reception at the MDM. The latency needed using the request/response protocol depends on how the MDM is configured to read the meters (how many with one request and how much data). In the case of one meter and minimal data the timeout is around five to ten seconds to ensure reasonable timestamping on reception at the MDM.

7.1.3 Use case service requirements

See Appendix I. Further details on service requirements for this use case may be provided in a future version of this Technical Paper.

7.2 Use case 2: Smart meter GW

7.2.1 Use case description

Worldwide, there is a significant trend for a change in the energy system to a renewal energy generation. This leads to a complete change of the topology of the generation infrastructure. When the legacy system makes use of centralized generation, mainly using fossil or nuclear sources, the new system will mainly rely on distributed energy sources. See Figure 7-1.

The consequence of this is the need of synchronization of these energy sources. Consequently, there are requirements for the transmit of metering and sensor information from energy generators (e.g., photovoltaic systems), local energy storage (e.g., electric vehicles) and consumers as well as for the control of actors making use of SCADA communication. The main requirements for this type communication are:

- Good rate of availability and reliability (>98%)
- Broadband communication with moderate bitrates
- IP-based communication
- Low latency
- High degree of IT security (especially authenticity)
- High coverage of the energy network

Finally, this change will lead to a local independent energy network, where generation, storage and consumption should be balanced. New business models like smart contracts based on block chain technology will occur.

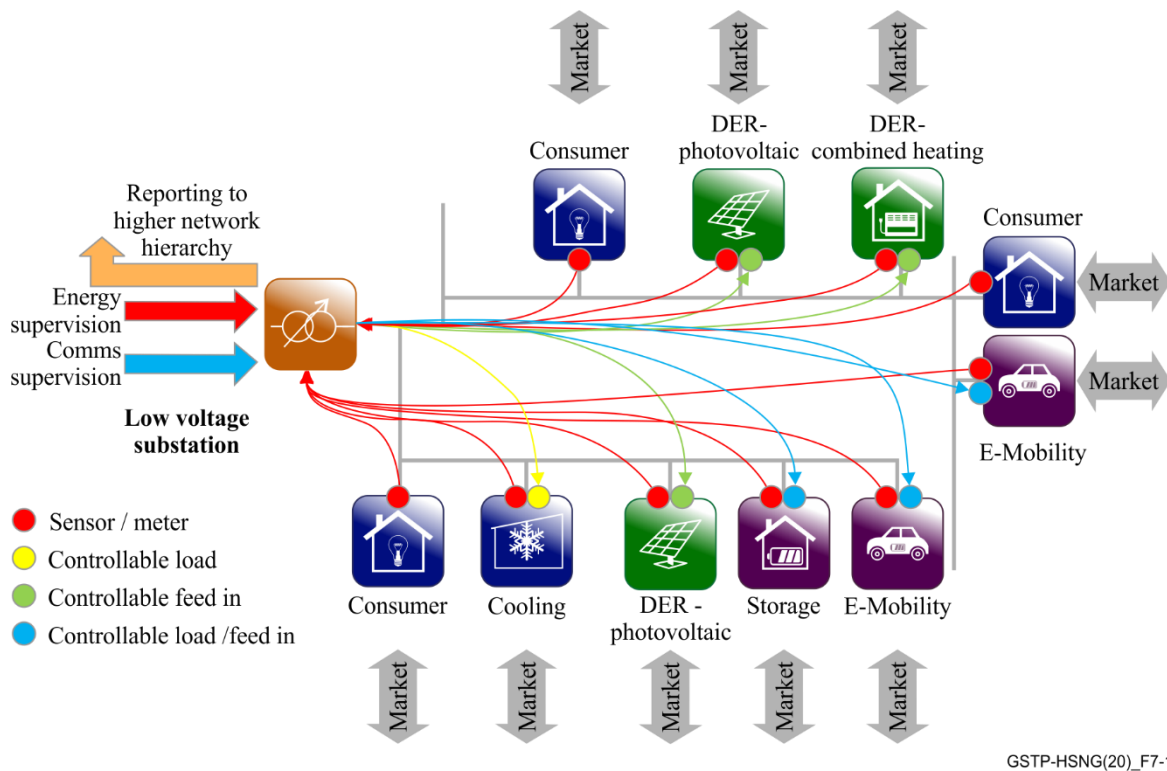

Figure 7-1 – Addressed topology

As a result, there is a requirement in low voltage networks, to have broadband communication between the secondary substation and the customer premises along the energy network. Making use of broadband powerline technology is the logical consequence.

A separation of the communication between the access network (wide area networks (WAN)) and in-house communication (home area networks (HAN), local metering networks (LMN)) is another part of the requirement.

Home gateway (smart meter gateway), as a trusted local entity, was defined to provide different services:

- **Collecting metering data in local metering network:** The smart meter gateway collects meter data information from different meters in the home area. Meters are normally connected via narrowband technologies like
 - Narrow band powerline systems (ITU-T G.9903, ITU-T G.9904)
 - Serial Lines e.g., ITU-T V.11, ITU-T V.24
 - Radio Technologies in ISM Band (Wireless MBus)
- **Providing tariff information in home area network:** Home control systems need access to the actual energy tariffs to control the energy consumption based on the energy costs. The tariffs are made available on the home area network (HAN) as a web service, so IP-type communication is necessary. The smart meter gateway provides an Ethernet interface for the HAN. In-home broadband powerline communication may be used to distribute this information to the customer's home control systems.
- **Controlling local generation, storage and load in home area network:** To keep generation, storage and load in a defined balance and to prevent the energy network from overload, the distribution network operator may control local generation (e.g., photovoltaic inverters), storage (e.g., electrical vehicle chargers) and load (e.g., air condition systems or boilers). This also requires IP-type communication based on Ethernet. In-home broadband

powerline communication may be used to distribute this information to the controlled devices.

- **Retrieving measurement data out of the electrical grid, making use of powerline repeaters:** Utilities want to retrieve online measurement data from the electrical grid. Most important in low voltage networks is the voltage level on all phases with respect to ground. The powerline repeaters placed in existing street cabinets need to provide this information.

Finally, smart meter gateway architecture will have this overall topology shown in Figure 7-2.

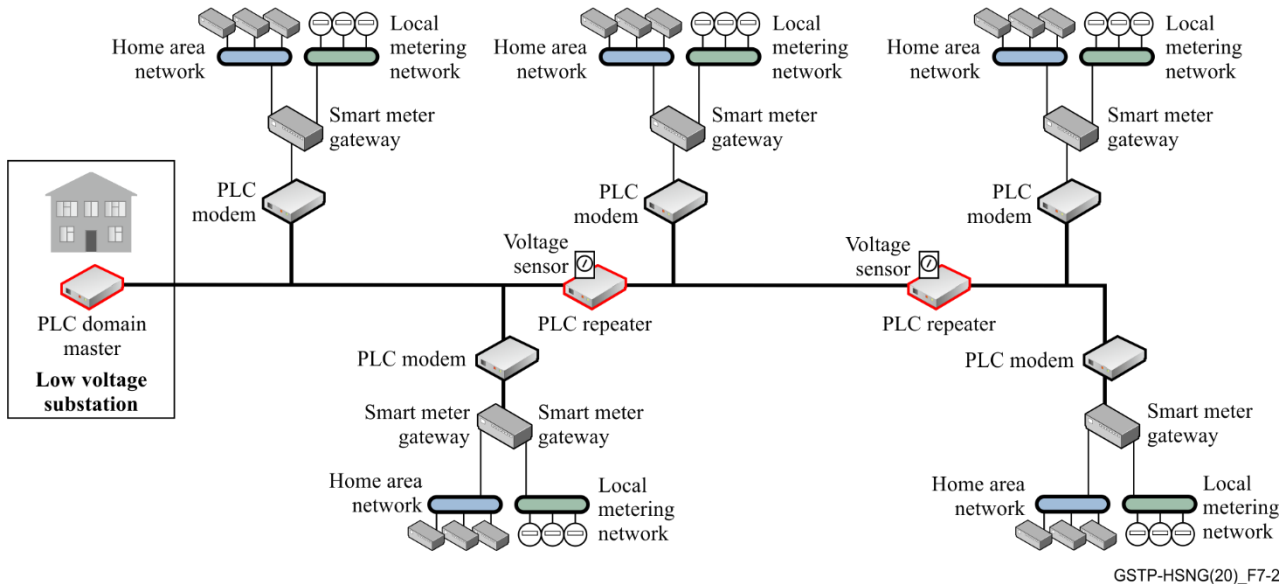

Figure 7-2 – Use case architecture

7.2.2 Use case guidelines

The following clause defines some guidelines for the deployment of this use case.

7.2.2.1 Physical constraints

A general design criterion for the home gateways is to place only one of the gateways in a house. This leads to the following limitations:

- **Density of BPL modems in suburban and rural areas:** In suburban and rural areas, it may occur that the attenuation of the electrical grid exceeds the maximum range of the modems. Therefore, it is necessary using repeaters in the topology.
- **Coexistence with xDSL and in-home powerline systems:** Telecommunication cables are installed close to electrical lines. Limiting interference must be considered. Moreover, the access – powerline systems should coexist with existing home powerline systems.
- **Interference to radio telecommunication systems:** The powerline system must provide measures to prevent interfering with radio telecommunication systems (e.g., radio broadcast, HAM radio, commercial radio).
- **Compliance to local EMC law:** The powerline system must comply with local electromagnetic compatibility (EMC) law, such as CENELEC, CISPR, etc.

7.2.2.2 Rollout constraints

The rollout of smart meter gateways will not be in a topological optimized way.

For mitigation, the system should support the following approach:

- **First step:** Rollout of the BPL master in the low voltage substation;

- **Second step:** Deployment of a sufficient number of nodes with repeater functionality e.g., in distribution cabinets along the electrical feeder, to support full coverage of power line in the whole electrical grid;
- **Third step:** Rollout of gateways in the houses and adapting the network (routing, use of repeaters) to optimize performance.

7.2.3 Use case service requirements

The powerline system should provide the services detailed below.

7.2.3.1 Transparent Layer 2 and IEEE 802.1p/q

The powerline system needs to provide transparency on network Layer2. It should transport tagged Ethernet frames with an adjustable MTU size. The management interface of the powerline modem should have a configurable VLAN assignment. Therefore, the modem must remove the tagging for management access.

The Ethernet interface of the modem should be able to work in different modes:

- **VLAN trunk mode:** The modem will pass Ethernet frames with configurable tags to the Ethernet interface. No removal of VLAN tags;
- **VLAN access mode:** The modem will pass only Ethernet frames with a specific tag to the Ethernet interface. On egress Ethernet frames, the configured VLAN tag will be removed. On ingress Ethernet frames, the configured VLAN – tag will be added.

Figure 7-3 depicts the VLAN architecture.

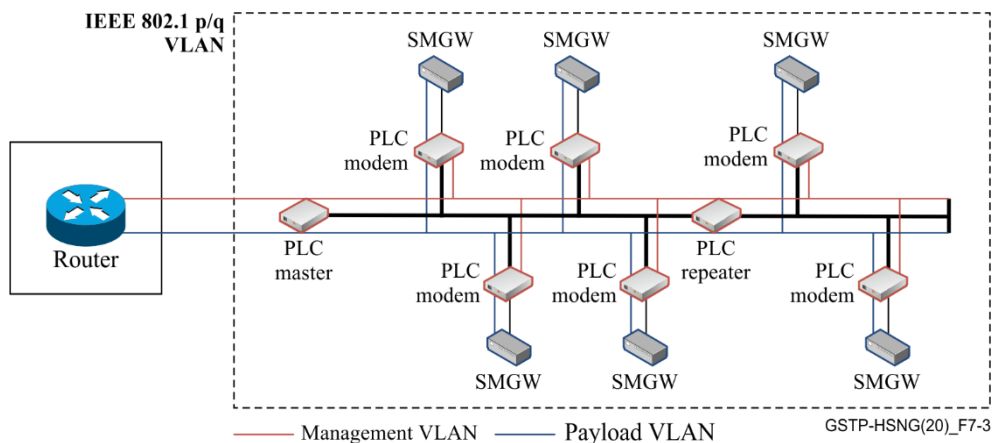

Figure 7-3 – VLAN architecture

7.2.3.2 Support of Layer 2 multicast and broadcast

The powerline system needs to provide layer 2 multicast and broadcast support. Broadcast frames should be forwarded to all powerline devices.

For layer 2 multicast support, the powerline system should forward multicast frames only to affected devices and powerline nodes.

7.2.3.3 Support of E-LAN and E-tree topologies

The powerline system should support Ethernet local area network (E-LAN) as well (communication between all Ethernet interfaces from domain master and modems) as E-tree (communication between Ethernet interface of modem only to domain master possible, no communication between Ethernet interfaces of modems) topologies. See Figure 7-4.

NOTE – This does not imply any specific underlying network topology.

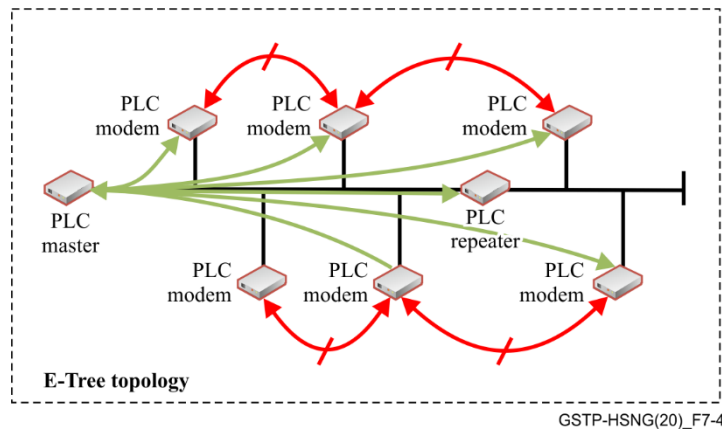

Figure 7-4 – E-Tree topology

7.2.3.4 Class of service and prioritization

The powerline system should have different priority queues for prioritization of Ethernet traffic. It should make use of the priority levels as described in IEEE 802.1 p. The priority code point (PCP) values on the Ethernet interfaces should be mapped to the transport level. It should be possible to configure the Ethernet interface to:

- **Keep the PCP value:** The modem will keep the PCP value of the Ethernet frames and map the values to the internal prioritization queue;
- **Discard the PCP value and set:** The modem will pass only Ethernet frames with a specific tag to the Ethernet interface. On egress Ethernet frames, the configured VLAN tag will be removed. On ingress Ethernet frames, the configured VLAN tag will be added.

See Table 7-1 for the list of priority mappings.

Table 7-1 – Priority mapping

| PCP value | Priority | Acronym | Traffic types |
|-----------|-------------|---------|-----------------------------------|
| 1 | 0 (lowest) | BK | Background |
| 0 | 1 (default) | BE | Best effort |
| 2 | 2 | EE | Excellent effort |
| 3 | 3 | CA | Critical applications |
| 4 | 4 | VI | Video, <100 ms latency and jitter |
| 5 | 5 | VO | Voice, <100 ms latency and jitter |
| 6 | 6 | IC | Internetwork control |
| 7 | 7 (highest) | NC | Network control |

7.2.3.5 End to end bandwidth and latency

The powerline system should provide a mechanism to determine the available bandwidth.

This might be based on:

- **Best effort:** Every node gets maximal available resources.
- **Low latency:** The network will be optimized to low latency.
- **Constant minimal bitrate:** Each device will have the same bandwidth to the domain master.

7.2.3.6 Network access control

See clause 7.2.4.3 for security guidelines.

7.2.4 Deployment/operational guidelines

7.2.4.1 Physical layer self-configuration of the topology

The powerline network should automatically build its topology. It should be possible to define dedicated repeaters which are relaying data for connected devices. The topology should be built and optimized based on:

- Number of hops;
- Available bandwidth;
- Latency;
- SNR;
- Bit error rate.

See Figure 7-5 for an example of a self-built network.

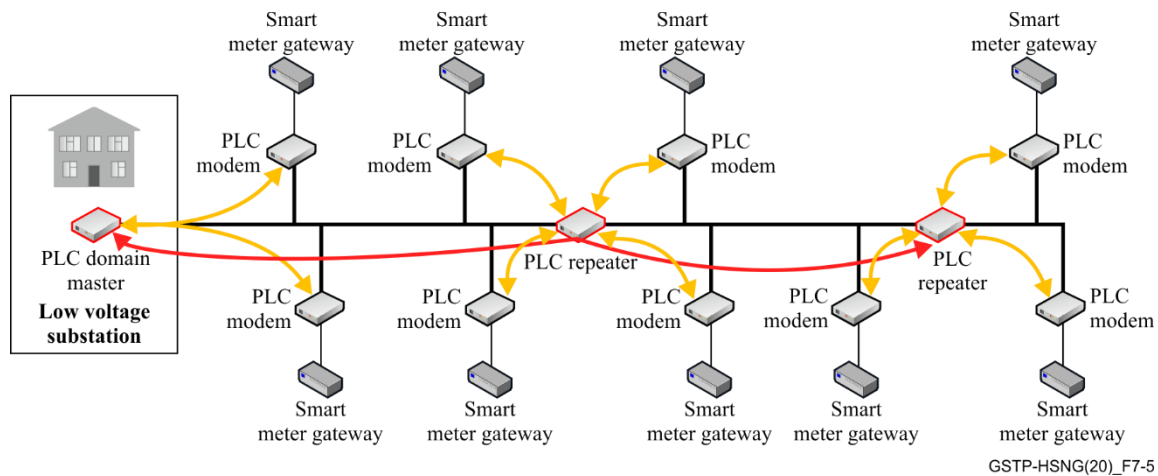

Figure 7-5 – Example of self-built network

7.2.4.2 Run time adaptation of the topology

The powerline system should dynamically update the topology when the parameters described in clause 7.2.4.1 change. A threshold for topology change should be implemented, to prevent the system from flapping.

Reasons for adaption of the topology might be:

7.2.4.2.1 Failure of powerline devices (e.g., Repeater went down)

When a repeater goes down, the topology should be rebuilt based on the predefined criteria. This might lead to changes on the assignment of modems to the repeaters. See Figure 7-6.

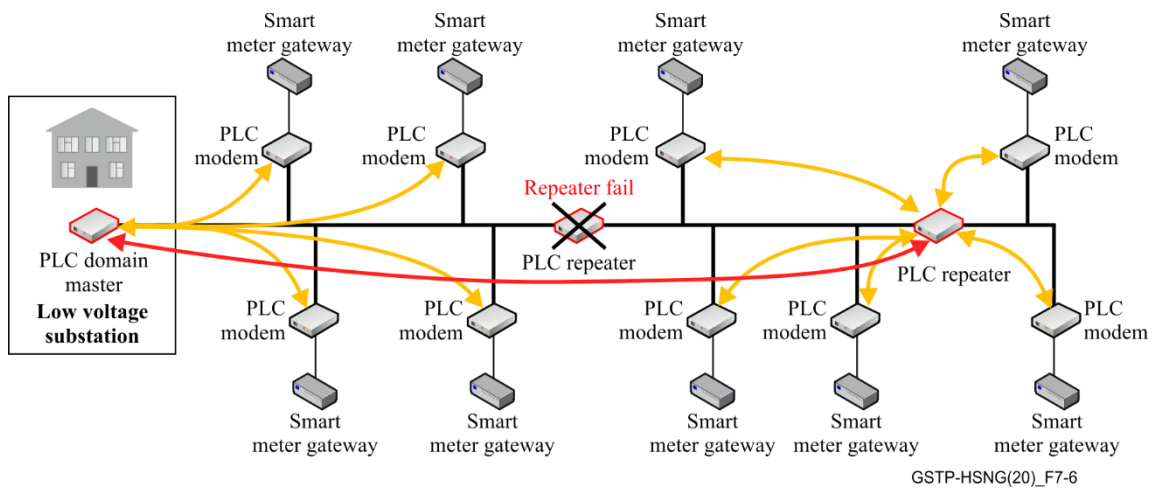

Figure 7-6 – Example of change in the network

7.2.4.2.2 Change in powerline channel characteristics

Because of a change of the channel characteristics (e.g., interference), a modem could be using a path with lower noise instead of using the strongest signal. See Figure 7-7.

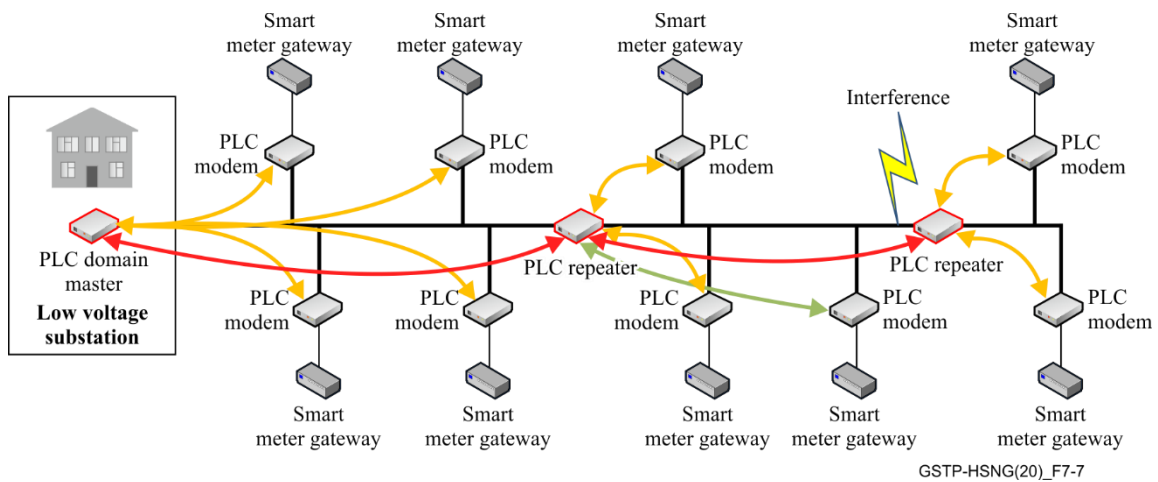

Figure 7-7 – Example of change in the network (2)

7.2.4.2.3 Re-configuration/Self-healing

For special use cases (e.g., no street cabinet available for a repeater), it might be necessary to define an endpoint to act as a repeating device. See Figure 7-8.

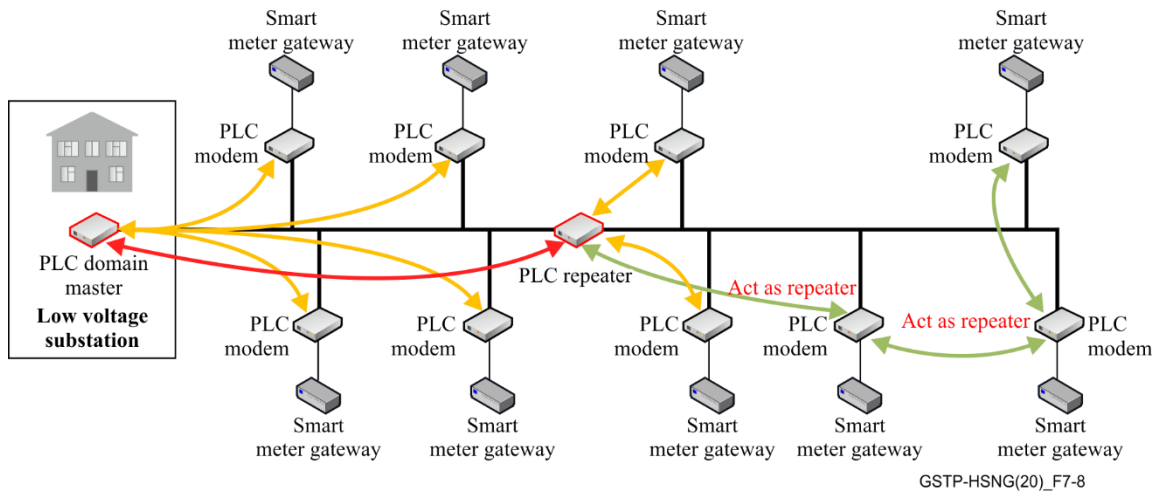

Figure 7-8 – Example of change in the network (3)

7.2.4.2.4 Ability to overrule the connectivity decision of the underlying powerline technology

For special use cases, e.g., when the topology is flapping continuously, it might be necessary to overrule the decision made by the powerline technology and to manually define the topology. See Figure 7-9.

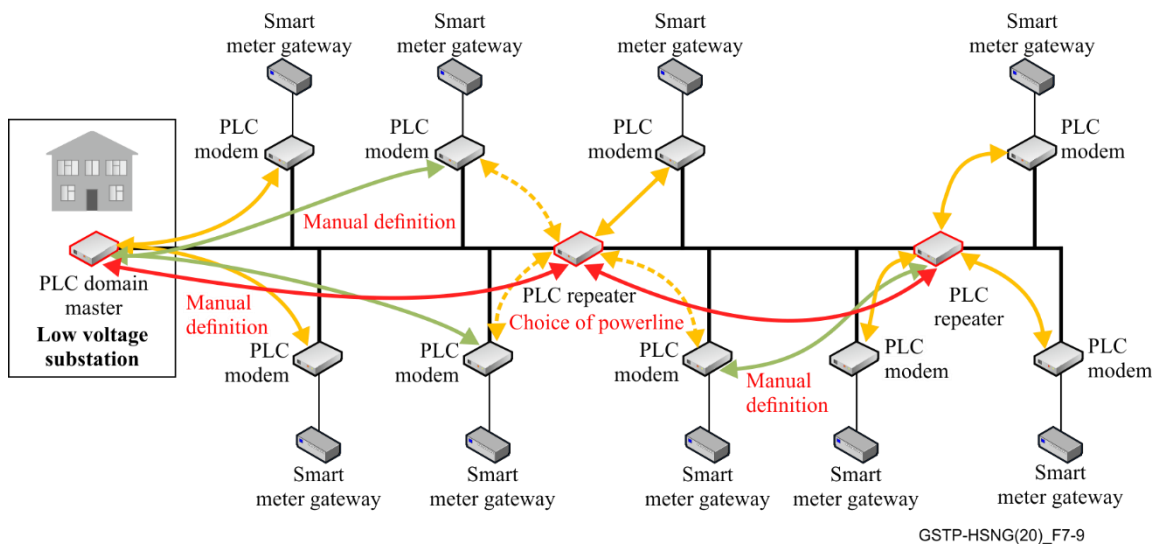

Figure 7-9 – Example of change in the network (4)

7.2.4.2.5 Hand over between LV networks

In normal operation, adjacent networks should build the topology based on the common rules as defined in clause 7.2.4.1. The network should converge to the optimized performance. See example in Figure 7-10.

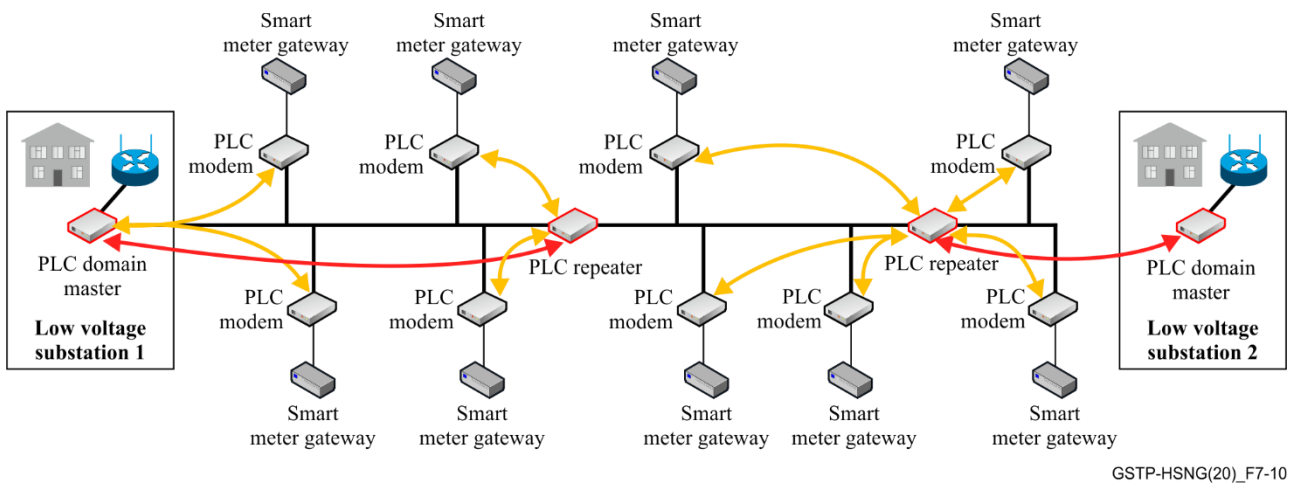

Figure 7-10 – Example of change in the network (5)

7.2.4.2.6 Connectivity failure toward the backhaul (e.g., LTE line went down)

When the backhaul connection goes down, the domain master (DM) connected to the failure device should invoke a reconfiguration of the topology, resulting in switching over to the new adjacent domain. See Figure 7-11.

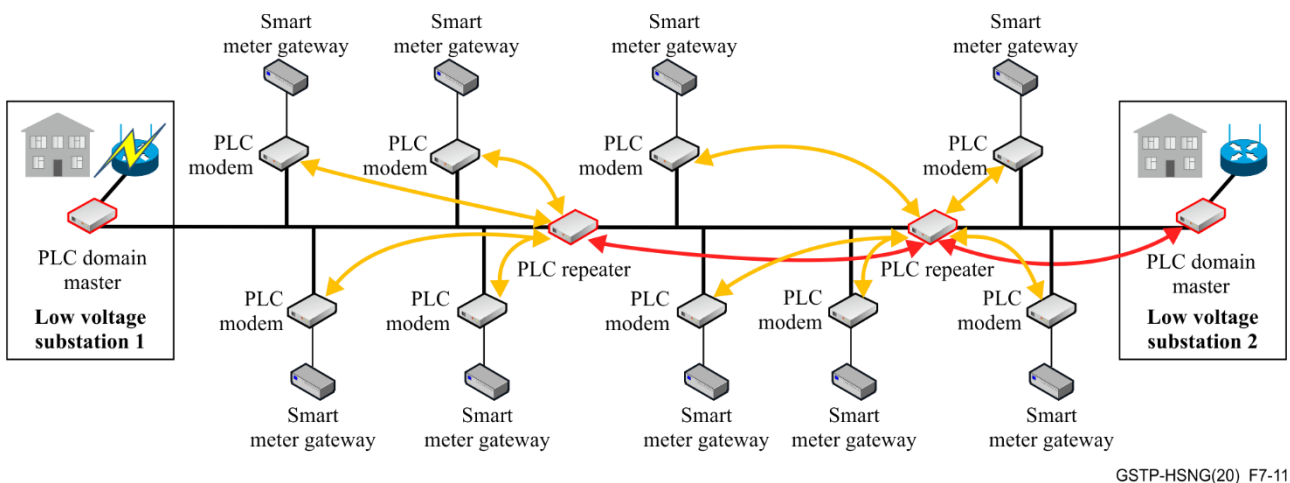

Figure 7-11 – Example of change in the network (6)

7.2.4.2.7 Powerline device failure (e.g., DM went down)

When the domain master fails, the powerline network should start to reconfigure following the rules as defined in clause 7.2.4.1. Finally, all powerline devices will be connected to the adjacent DM. See Figure 7-12.

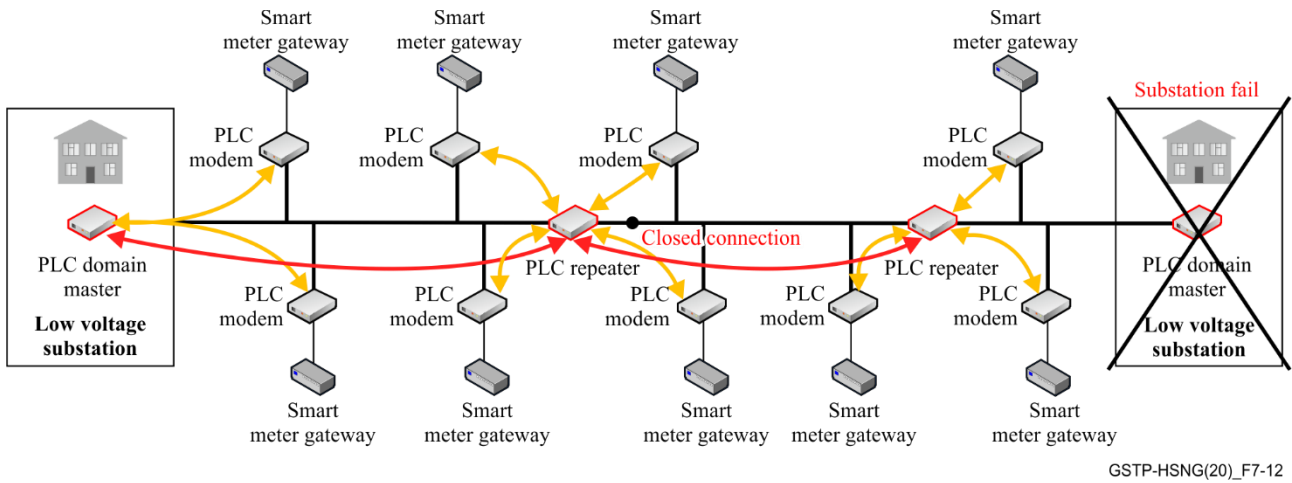

Figure 7-12 – Example of change in the network (7)

7.2.4.2.8 Grid topology change e.g., switch change by utility

Due to construction work, or to shift load, it might be necessary to change the topology (e.g., switch change). When this occurs, the powerline network should build its topology as described in clause 7.2.4.1. See Figure 7-13.

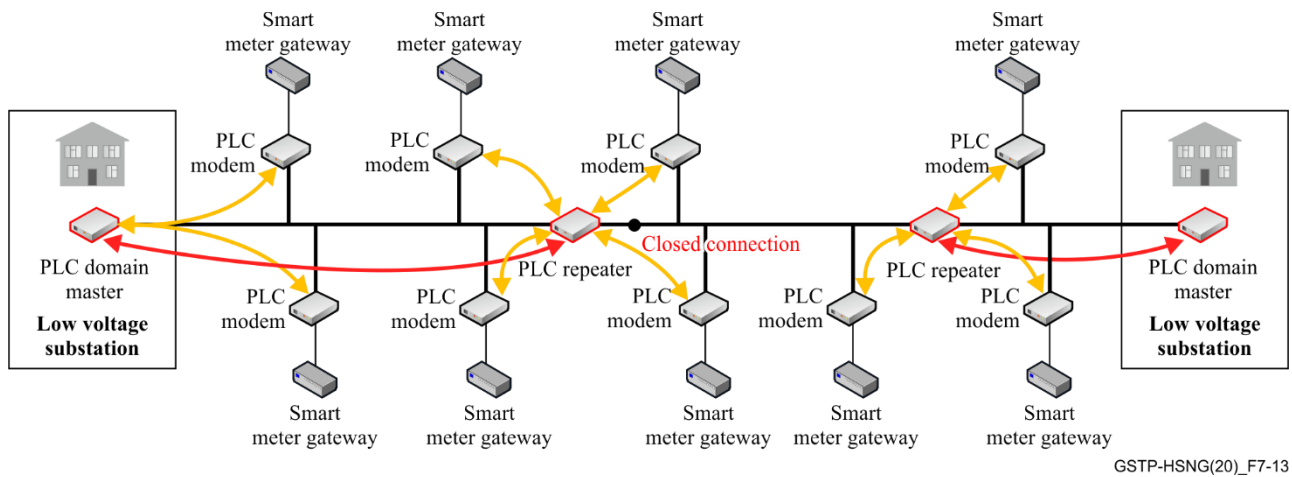

Figure 7-13 – Example of change in the network (8)

7.2.4.2.9 Overlap between several networks

In normal operation, low voltage networks operate in a star topology. There is a good degree of isolation between the networks. The topology is built independently. See Figure 7-14.

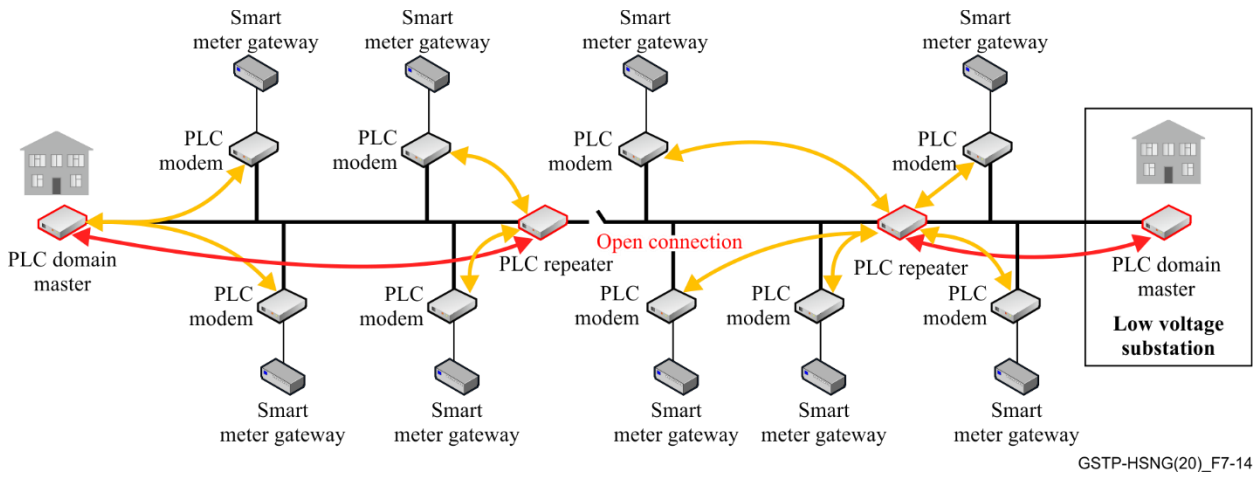

Figure 7-14 – Example of change in the network (9)

7.2.4.2.10 Multi feeder injection from a single device

In typical substations, there are multiple feeders connected to a busbar. This busbar inserts a high attenuation into the powerline signal, and it might have better results if multi feeder injection is used. The topology should be built independently from the injection. See Figure 7-15.

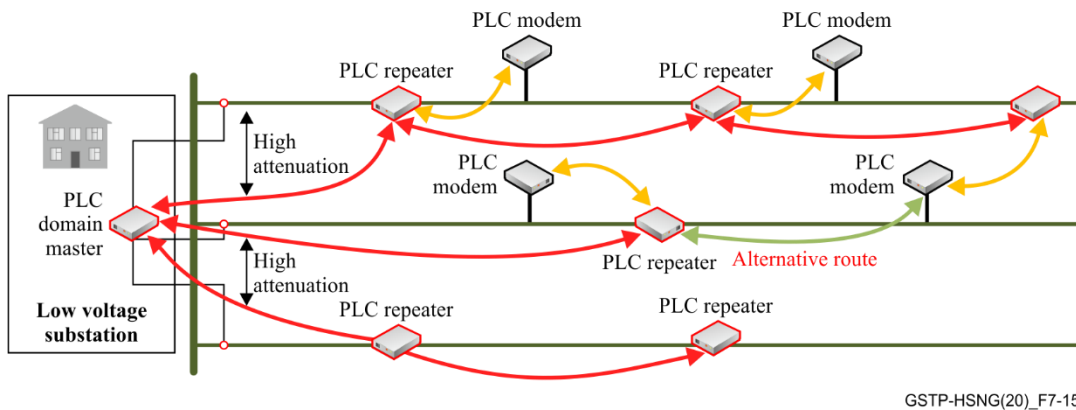

Figure 7-15 – Multi feeder injection

7.2.4.2.11 Injection on different feeders from several devices with non-perfect isolation

In large low voltage substations with wide-range busbar, it can be necessary to use several powerline masters. The DMs must coexist in this environment. See Figure 7-16.

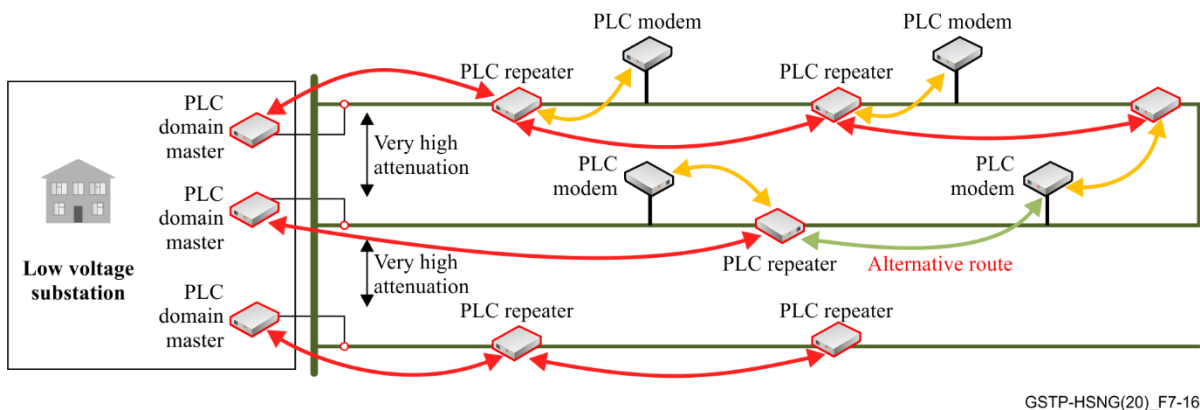

Figure 7-16 – Multi feeder injection (2)

7.2.4.3 Security guidelines

7.2.4.3.1 Each powerline modem and each client device outside a low voltage substation has to be treated as an unsecure untrusted device to the network.

7.2.4.3.2 The **Smart grid head end node** (SG-HE) or the authenticated SG-REP device should have the ability to act as an authenticator for BPL – Devices in order to forward authentication requests to a central AAA (e.g., RADIUS – Server).

7.2.4.3.3 The authentication of the BPL modems should be realized with IEEE 802.1x.

7.3 Use case 3: narrow-band smart meters concentrator

This clause describes the use case of a low-voltage BPL concentrator for existing narrowband powerline communications (NB-PLC) smart meters, but which could in principle be generalized to any case in which a BPL concentrator is used to provide connectivity to an existing set of devices that use NB-PLC operating below 2 MHz.

This use case is relevant to any utility that might have deployed or be in the process of deploying its automatic meter infrastructure (AMI) solution based on narrow-band powerline communications (NB-PLC) operating below 2 MHz. Being aware that the amortization period of newly installed narrow-band smart meters may represent a handicap for the early replacement of these elements, this use case offers the possibility of not deferring any deployment, while at the same time offering an evolutionary way-forward.

7.3.1 Use case description

The use case proposes the deployment of broadband powerline communications (BPL) at the aggregation points of the LV network (mainly meter rooms) and using NB-PLC communications locally only to communicate meters with a nearby NB-PLC base node that could be connected to the BPL device (e.g., by Ethernet). In the generalization of the use case, we could have any other telecommunication technology instead of NB-PLC.

As already mentioned, in a broader sense, the general architecture could be to install BPL devices in the aggregation points of the LV grid, and encapsulate over IP the traffic the meters produce through serial ports (RS-232, ...) or through the wireless connectivity the meter has (Zigbee, ...) or whatever other approaches are available. This architecture is represented in Figure 7-16 "LV with BPL concentrators".

If BPL meters are available at competitive price, this architecture has to be prepared to allow the BPL meters to be integrated in the SS BPL network smoothly, simply replacing the old NB-PLC meter with the new one (BPL). This architecture is represented in Figure 7-17 "LV with BPL smart meters".

This coexistence of both PLC solutions in the LV grid is possible due to the different frequency bands that each solution uses: over 2 MHz for BPL and under 500 kHz for NB-PLC.

This approach presents several advantages for utilities that have deployed NB-PLC meters, including protection of already made investments, the opportunity to open the door to additional smart grid applications in LV like grid sensing, distribution automation or the integration of distributed energy resources and finally providing the possibility of increasing performance (reading frequency and reading granularity) for metering where needed.

7.3.2 Use case guidelines

The high variability of LV networks around the world implies a challenge where BPL solutions have to be designed to maximize the footprint where broadband connectivity can be achieved. The factors and aspects to be taken into account are manifold, but the following can be highlighted:

- Coexistence mechanism with MV BPL solutions (where present).

- Mechanism to avoid, or at least minimize, the effect of interferences/noise (use of filters as a last resort).
- Frequency bands available.
- Maximum number of hops between master and slave.
- Distance to be covered in a single hop: 200 m in underground cables and 1 km in overhead cables.
- No touch commissioning mechanism for easy deployment.
- Compliance with relevant cybersecurity standards.

In some deployments, LV grid has a radial topology, and each secondary substation (SS) has a unique domain; which means that LV installations depend always on a single SS. Each LV line is composed of three phases and neutral (4 cables) and the signal injection is done with capacitive couplers; the NB-PLC signal is currently injected to one phase and neutral (230 VAC).

The LV grid presents two main problems:

- The attenuation of LV feeders and
- The noise level detected in some installations (due to lifts, energy-efficient light bulb, engines, etc.) whose the source is often not easily identified or filtered; sometimes it is not present all the time (and depends on the hour or the day). Noise or interference problems may complicate the commissioning of BPL solutions, so it is important that BPL equipment automatically adapts to time-variant noise conditions without human intervention.

7.3.3 Use case service requirements

The following requirements are considered for this use case:

- **Number of BPL nodes coexisting in the same BPL domain:** will change with time, as the penetration of BPL increases:
 - As a first step, the approach would be to install a BPL gateway in the meter rooms of the most populated and urban secondary substations: in SSs with hundreds of customers, the NB-PLC data concentrator that is installed in the SS cannot recover the information of the smart meters as frequently as it will be needed (15 minutes, 5 minutes,...). In this case, the BPL domain would be limited to the needed number of BPL devices to reach meter concentrations in buildings and should be able to support tens of nodes.

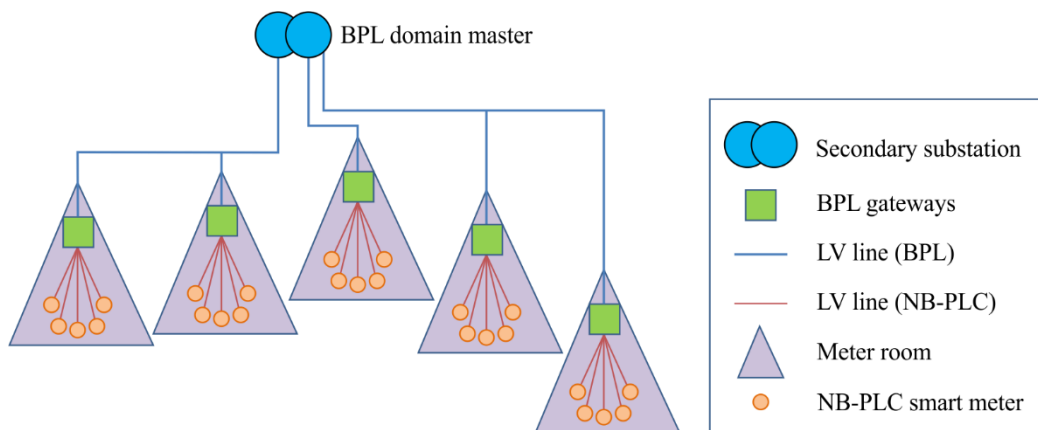

GSTP-HSNG(20)_F7-17

Figure 7-17 – LV with BPL concentrators

- In the future, after current NB-PLC meters' amortization, it would be possible to replace old meters by new BPL meters. In this case, a BPL domain should be able to support hundreds of nodes (maybe one thousand).

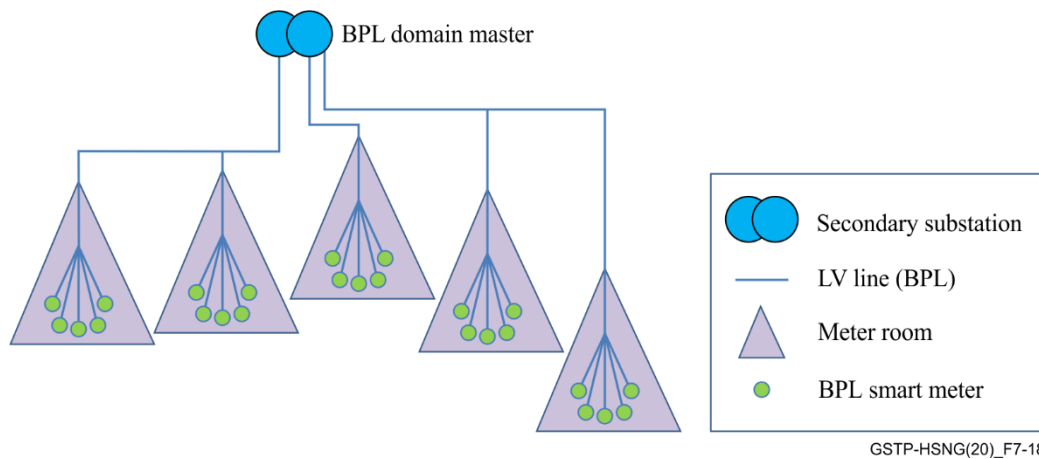

Figure 7-18 – LV with BPL smart meters

- The minimum bandwidth requirement (measured at the application level and having simultaneous traffic with all the nodes) will be dependent on the number of nodes. In the initial phase (with up to 100 nodes), each node is concentrating data from several tens of meters, so the bandwidth requirement per node is higher: 50 kbit/s. As the penetration of BPL increases (until the extreme case in which all meters are BPL) the bandwidth requirement per node will be reduced.

7.4 Use case 4: MV backbone

7.4.1 Description

The use of BPL technologies in MV grids as a complement of WAN access solutions at secondary substation level for smart grid services is inherent to public utilities: using medium-voltage power lines as a means of data transmission is a great advantage in itself. There are industrial and mature solutions in the market that allow for ambitious MV BPL deployments to be made with a sufficient degree of operational performance, resilience and efficiency. There are however still many improvements needed in order to have more homogeneous (standard) solutions that will allow electric utilities to have a reference architectural framework based on standards and will seek a better adaptation of equipment and components to this use case (maximizing the degree of coverage and performance, simplifying network planning, optimizing flexibility to manage changes in the MV electrical topology, etc.).

The design of the MV BPL networks must be based on design rules that, although based on a common approach, may need to be adapted to the specific characteristics of the utility MV network (topology, types of cables, types of switches, age of assets, etc.). A good GIS-based asset inventory is instrumental for the deployment of a BPL-based roll-out. Figure 7-19 shows an example of the topology of an underground MV grid (with point-to-point MV feeders), where distances between SSS and type of MV cables are indicated:

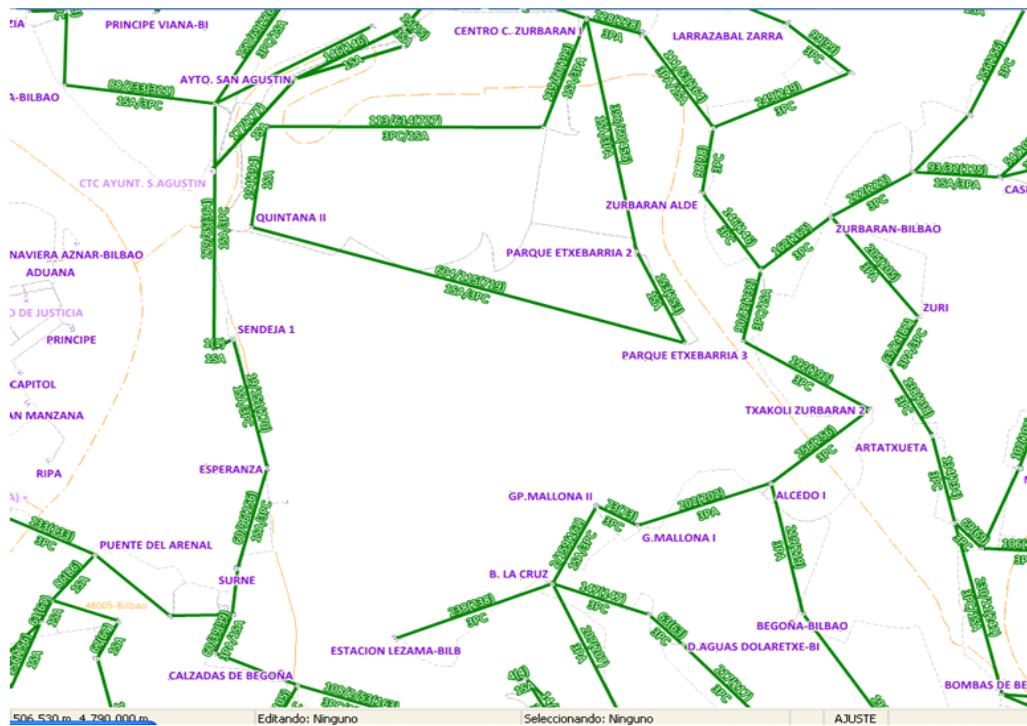

Figure 7-19 – Physical and logical connection of SSs

The MV grid may have different characteristics depending on the geographical area:

- In **rural areas** the MV grid has overhead cables which may have branches (bus topology, tree-shape).
 - i) The attenuation of these cables is lower for BPL frequencies (above 2 MHz), but the risk of interference may be an important problem.
 - ii) The distance between SSs is longer (it may vary from hundreds of meters to 7 kilometres).
- In **urban areas** the MV grid has underground cables, with point to point MV links between SSs. The distance between SSs is short (it may vary from 100 to 1000 metres).

In every SS, the BPL signal is injected to the MV feeder using one capacitive coupler that is connected to one phase and its ground. The MV feeders have three phases and no neutral cable.

7.4.2 Use case guidelines

BPL MV design is also influenced by the BPL technology itself (modulation, frequency plan, component roles, maximum data speed, scalability, etc.).

As it is not possible to have infinite SSs in the same BPL domain with infinite throughput, it is necessary to plan several domains or BPL cells in the same geographical area, each respecting different BPL constraints.

Some design criteria have to be provided, looking to achieve the required throughput in each secondary substation (depending on the services to be provided for each site), and the planning rules that have to be taken into account need to be specified:

- Strategy and design at frequency level for the creation of domains of BPL connected SSs.
- Maximum number of nodes per BPL domain (based on plain networking aspects – layer 2 and layer 3 aspects). A typical BPL domain would have 20 nodes (secondary substations).
- Maximum number of consecutive hops in a chain of BPL nodes.

- Maximum number of BPL hops to reach the SS with backbone connectivity: up to 10 hops in the BPL domain from the furthest nodes to the domain master.
- Maximum number of BPL links (MV feeders) in a secondary substation: 8.
- Legacy BPL deployments in the MV grid which use either 2-7 MHz band or 8-18 MHz band, which may be located nearby and could create interferences to new G.hn BPL domains.
- Typical distance per BPL link: 1km in underground MV grid, 2 km in overhead MV grid.

Thanks to previous BPL deployments in Spain ([Sendin, 2016], [Dominiak, 2012], [Sendin, 2014]), working in the 2-18 MHz band, it can be estimated that, in the underground MV grid, the attenuation of "old MV cables" may be twice the attenuation of new MV cables.

Figure 7-20 gives an example of a BPL network in a specific urban area of Spain, where several BPL domains have been planned and deployed. Lines in red show BPL links working in Mode 1 (2-7 MHz), and lines in blue show BPL links working in Mode 2 (8-18 MHz). The image highlights the effect of interferences between different but close BPL cells working in the same frequency mode.

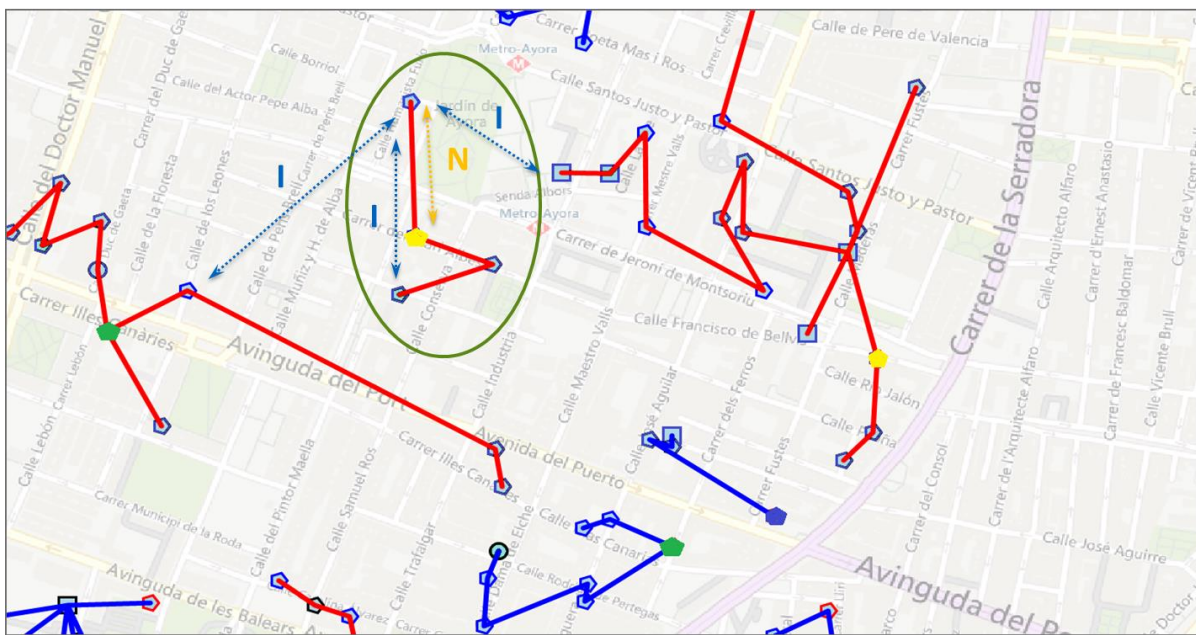

Figure 7-20 – Example of MV BPL network plan

Furthermore, BPL gateways must be able to manage the different signal levels that may be received from different secondary substations. When installing a BPL domain master in a primary substation, it may have 8 direct links through 8 MV feeders to different remote secondary substations, and as a result the conditions of attenuation and noise may be very different in each of these BPL links.

7.4.3 Use case service requirements

The main and traditional services for the distribution system operator (DSO) are digital automation (DA) and advanced metering infrastructure (AMI) services to SSs, however new applications such as video surveillance, electric vehicle charging, and demand response can also be included in the future.

For this use case, the requirements for BPL solutions are the following:

- A minimum bidirectional and simultaneous application level throughput of 100 kbit/s (application layer) should be obtained at every SS (AMI and DA services).
- A minimum physical level throughput of 10 Mbit/s should be obtained in both senses (downstream and upstream) in every BPL link of the domain. Considering an attenuation per BPL link of 85dB in the 2-32 MHz band.

8 Coexistence and interoperability

8.1 Coexistence between G.hn smart grid system and PLC in-home systems

Coexistence is the ability of different systems or technologies to work properly together.

In the context of PLC, the following two systems "wrestle" around the medium of the power line:

- An access G.hn smart grid system: Usually used for communication between the transformer stations and the PLC modems at the houses.
- One or more in-home PLC systems: Usually used for distribution of internet within a house.

The electricity grid has a coherent structure that does not end at the house or apartment boundary. Therefore, the signals from an in-home system typically do not end at the house boundary, and similarly the signals from the access system can go through the electricity smart meter into the apartment. Due to attenuation effects on PLC signals that are caused by power cables inside and outside the house, and the electricity meter, the medium sharing effects are reduced, and these two systems are partially decoupled. However, there is no complete decoupling between in-home and access systems. Figure 8-1 describes the coexistence problem between in-home and access systems.

Coexistence between the G.hn smart grid system and PLC in-home systems, as described in Figure 8-1, is required (see clause 10.2.1).

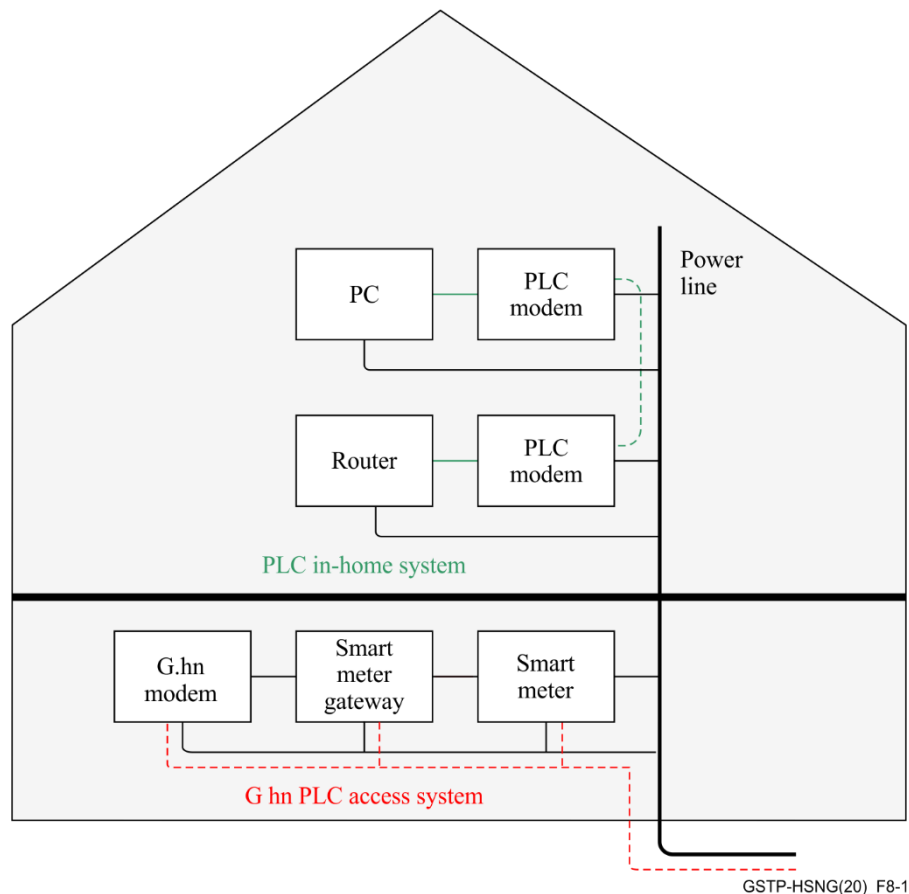

Figure 8-1 – coexistence issue between in-home and access PLC systems

8.2 Interoperability between different G.hn smart grid vendors

In some countries the energy market is deregulated. There are not only rather large utilities, but also many network operators. For the rollout of smart grid applications, we can distinguish between distribution network operators (DNOs) and metering operators (MOs). The DNO is responsible for

the secure, reliable and economical management of the distribution networks. The task of MO is to install metering devices and operate billing services.

Based on this situation of the distribution network, there could be situations where several MOs integrate their own G.hn modems (possibly from a third party) into the existing access system of the DNO without its own G.hn headend as described in Figure 8-2.

The interoperability between G.hn modems of the DNO and G.hn modems of the MOs, as described in Figure 8-2, is required.

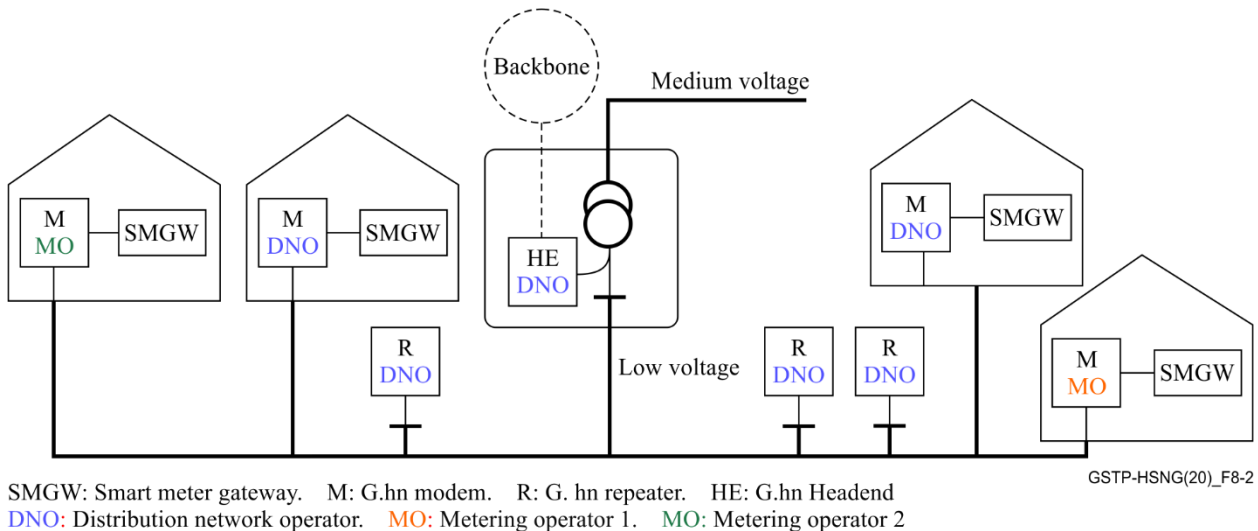

Figure 8-2 – Interoperability scenario between G.hn modems from different smart grid vendors that installed by various operators

9 Telecommunication infrastructure based on G.hn technology

9.1 BPL network node types

There could be several types of nodes in a G.hn telecommunication network for smart grid, shown in Figure 9-1 (the same colour code will be used in the rest of this Technical Paper).



Figure 9-1 – Smart grid types of nodes

The different node types in smart grid are:

- **Smart grid head end node (SG-HE):** G.hn node that is connected to the backhaul of the smart grid network.
- **Smart grid network termination (SG-NT):** G.hn node that is connected to an end user device (e.g., smart grid gateway, meter).
- **Repeater (REP): (SG-REP):** G.hn node that incorporates a repetition function (e.g., it is used to repeat the signal received from one of its G.hn links through the other G.hn links in order to increase the reach of the network). It can be of two types:

- **SG-REP**: The node acts only as repeater;
- **SG-REP-NT**: The node acts as repeater but also has end devices connected to it.
- **Smart grid inter domain bridge**: A G.hn inter-domain bridge as described in clause 5.1.6 of [ITU-T G.9960].

9.2 Tree topology

9.2.1 Challenges of tree topologies in smart grid applications

In smart grid applications, the logical topology of the network will likely be a tree of nodes.

This tree will be composed of "branches" with different levels of density of nodes in each of the branches. Some of these branches will have some nodes connected to it while others will have a high density of nodes.

The composition and final structure of the tree will depend on the use case being handled. For instance, an MV backbone will have relatively low density of nodes, while a "smart meter" deployment will have clusters of nodes connected to some specific nodes that may concentrate information.

The physical infrastructure will influence the visibility between nodes and introduce a set of challenges that may be difficult to handle. Examples of these challenges are:

- **Hidden nodes**: When two nodes do not see each other but a third node sees both.
- **Groups of visibility**: The nodes that are physically close may not see each other (partial visibility) and nodes that are physically far away can have good visibility. The physical "groups" cannot therefore be extrapolated to "logical" groups.
- **Density of nodes**: In some areas (especially for smart meters scenarios), the density of nodes will be extremely high.

In addition to visibility constraints, several aspects will have an influence on the medium access control (MAC) policy:

- **Latency requirements**: Some types of traffic may have constraints on latency that makes the use of contention-based approaches impossible.
- **Reliability requirements**: Whenever the data may take long to be conveyed, but when a fixed delay is needed (e.g., synchronization).

The importance and impact of these challenges depend on the scenario. It is therefore impossible to write a general rule for a scheduling in smart grid networks. In this sense, the approach taken by G.hn is well suited for smart grid applications: G.hn offers a set of tools that, combined between them, allow to create the right scheduling for each situation.

9.3 Definitions for logical topology from powerline communication perspective

To describe the logical topology from the powerline communication perspective, some definitions are necessary:

A node is defined as a communication equipment, which communicates using G.hn protocols according to ITU-T G.996x Recommendations.

Link is defined as a communication channel between two nodes that can exchange data and control messages from the other according to ITU-T G.996x Recommendations.

A route is the sum of all required links from a node to the domain master. There may be more than one route possible.

The naming convention for the question, if at least one route is existing (True) from a node to the DM, is: r<node><DM>.

E.g., rAT is a route between node A and node T (DM).

Further conventions for this Technical Paper:

- A node is named with a capital letter, e.g., A;
- A link is named with the letters of the node involved in the link, e.g., AB;
- The following Boolean logic expressions are used:
 - False: = no link;
 - True: = link;
 - *= logical AND condition: = all conditions must be True for the term to be True;
 - += logical OR condition: = if at least one condition is True, the term becomes True.

Example 1:

The term $r_{AB} = AC * BC$ becomes True, if there exists a link between node A and node C AND also between node B and node C.

In this example, if the term $AC * BC$ is True, then there is a route rAB from node A to node B.

Example 2:

The term $r_{AB} = AC * BC + AD * CD * DE * EB$ becomes True, if at least one of the conditions $AC * BC$ OR $AD * CD * DE * EB$ is True.

In this example, if $AC * BC$ is True, then there exists one route rAB, and if $AD * CD * DE * EB$ is True, there is an alternative route rAB.

9.4 Other considerations on MV electrical topologies

In general, medium voltage grids have a networked topology. However, the utilities operate them as radial topologies opening certain stretches of the network. In case of an MV line failure, other lines which had been disconnected are connected to the network, allowing the delivery of electricity again to all the customers.

The presence of switchgears in the MV grid provides three possible states for an MV line between two secondary substations:

- Closed (the MV line is continued to the following SS);
- Open (the MV line finishes there and has not electrical connectivity to further SS's; no current is transmitted through the line);
- Grounded (the switchgear is open and the MV phase is connected to the ground of the SS, so there is a short circuit of the MV line).

These possible states must be taken into account when installing BPL systems so that these will work regardless of the state of the MV line.

For this reason, it is recommended to install the MV PLC couplers before the switchgears. MV PLC couplers are used to inject the PLC signal in the electrical cable, in a capacitive way or inductive way; and no switchgears should be in the middle of a BPL link to avoid the dependence of the state of the switchgears for the correct transmission of the telecom signal.

10 Implementation of use cases with G.hn technology

10.1 Use case 1: Smart meter

Implementation of this use case may be addressed in a future version of this Technical Paper.

10.2 Use case 2: Smart meter GW

10.2.1 Introduction

This implementation guidelines refer to the use case Smart meter GW described in clause 7.2.

| Constraint | Clause | Type | G.hn implementation / configuration |
|---|--------|---------------------|--|
| Relay function | 7.2.2 | Physical limitation | <p>To provide a higher flexibility in real rollouts, each node of the network may act as a repeater entity for the communication with nodes not directly reachable by the SG-HE (see clause 9.1)</p> <p>The repeater function is specified in the G.hn specification.</p> <p>Each node in the G.hn domain may act as a repeater node.</p> <p>The routing tables necessary for the relaying function will be created by the SG-HE and distributed to the rest of the nodes of the network.</p> <p>Clauses 5.6.7 and 5.6.8 of [ITU-T G.9961]</p> |
| Coexistence with xDSL | 7.2.2 | Physical limitation | <p>G.hn can coexist with xDSL installations as described in Recommendation ITU-T G.9977.</p> <p>In addition, PSDs used by G.hn systems are in accordance with CENELEC regulations.</p> |
| Coexistence with in-home powerline systems | 7.2.2 | Physical limitation | <p>G.hn offers a mechanism for distributed domain coordination (NDIM, see clause 8.14 of [ITU-T G.9961]).</p> <p>In addition, the coexistence with in-home G.hn systems may use the profile definition described in clause 8.1.4 of [ITU-T G.9961]</p> |
| Interference to radio telecommunication systems | 7.2.2 | Physical limitation | <p>Clause 5.3 of [ITU-T G.9964] describes a mechanism to notch frequencies that could be harmful to radio telecommunications systems.</p> <p>The international amateur radio bands are masked according to the G.hn specification.</p> <p>The PSD of the transmitted signal in all international amateur radio bands that are masked in the particular domain shall be at -85 dBm/Hz or lower.</p> |
| Smart meter rollout process | 7.2.2 | Rollout limitations | <p>Authentication process should be defined in the G.hn Recommendation.</p> |
| Support of physical mesh topology | 7.2.3 | Service Requirement | <p>G.hn supports physical mesh topologies through the topology protocol. See clause 8.6.4 of [ITU-T G.9961].</p> |
| Support of mesh and tree logical topologies | 7.2.3 | Service Requirement | <p>G.hn domain master can build the network routing tables in order to create different logical topologies explained in clause 8.6.4 of [ITU-T G.9961].</p> <p>Once the topology is created, the DM creates a schedule that optimizes the performance of the system for that particular topology. As examples, a logical tree topology can be scheduled in different manners:</p> <ul style="list-style-type: none"> – By using contention-based mechanisms (See clause 8.3 of [ITU-T G.9961]) |

| Constraint | Clause | Type | G.hn implementation / configuration |
|----------------------------------|--------|---------------------|---|
| | | | <ul style="list-style-type: none"> – By using a mix between contention-based mechanisms, contention-free mechanisms and hierarchical bidirectional messages, – etc. <p>The domain master has to choose the right scheduling for the topology it created.</p> <p>Since the topology and scheduling are created by the DM and distributed to the rest of the nodes of the network, there are no interoperability issues.</p> |
| IEEE 802.1 p | 7.2.3 | Service Requirement | <p>G.hn supports two QoS methods following clause 5.1.4 of [ITU-T G.9960]:</p> <ol style="list-style-type: none"> 1. <u>Priority-based QoS</u> – Priority-based QoS refers to a mechanism that provides different priorities for medium access based on the priority of the incoming traffic. All ITU-T G.9960 transceivers shall support priority-based QoS. The number of supported priority levels associated with the incoming application data primitives (ADPs) (at the A-interface) shall be eight (denoted from 0 to 7). 2. <u>Parameter-based QoS</u> – Parameter-based QoS mechanism operates per flow. Flows are set up, modified and terminated on a service basis. The characteristics of the service are used to select the QoS method used to deliver the traffic associated with the flow and to determine any relevant QoS parameters. Frames belonging to a specific flow are scheduled to be sent on to the medium in accordance with the defined QoS method. The ITU-T G.9960 QoS method handles both constant and variable data-rate traffic. <p>The mapping is defined in Appendix III of [ITU-T G.9960].</p> |
| End to end bandwidth and latency | 7.2.3 | Service Requirement | G.hn provides different set of tools to cope with bandwidth and latency requirements at various network conditions. |
| Network access control | 7.2.3 | Service Requirement | <p>Authentication process in this use case is done using 802.1X and follows the process described in Annex D of [ITU-T G.9961].</p> <p>This means that each powerline modem and each client device outside a low voltage substation has to be treated as an unsecure untrusted device until authenticated.</p> <p>In this process, the authenticator can be an entity located at the SG-HE or an external entity.</p> |
| Encryption | 7.2.3 | Service Requirement | In this use case, G.hn devices use cryptographic encryption as described in clause 9 of [ITU-T G.9961]. |

| Constraint | Clause | Type | G.hn implementation / configuration |
|---|---------------|------------------------------------|---|
| Physical layer self-configuring of the topology | 7.2.4.1 | Deployment/operational Requirement | G.hn is able to self-configure the routing information between the different nodes of the network as explained in clause 8.6.4 of [ITU-T G.9961]. The domain master receives the visibility information of any new node in the network. This visibility information is used to create the topology of the network. This process does not need manual intervention. |
| Run time adaptation of the topology | 7.2.4.2 | Deployment/operational Requirement | G.hn DM continuously receives updates on the visibility reported by the nodes of the domain and can update the logical topology of the network accordingly. However, the system allows also external entities to create the routing tables (see clause 8.6.4 of [ITU-T G.9961]) to support: <ul style="list-style-type: none"> a. Preferred routing b. forbidden/allowed domains and repeaters c. Asymmetric path |

10.3 Use case 3: narrow-band Smart meters concentrator

Implementation of this use case may be addressed in a future version of this Technical Paper.

10.4 Use case 4: MV backbone

Implementation of this use case may be addressed in a future version of this Technical Paper.

Appendix I

This appendix describes the traffic shapes required for the smart grid use case scenarios. Table I.1 provides a description for these traffic shapes.

Table I.1 – Traffic shapes for smart grid use case scenarios

| Traffic Name | Description | Type | Service | Direction | Initiator | xput | Max xput | Periodicity | Period | Shape | Avg Lat | Max Lat | Bytes trans | Max lat per trans | Num flows | Applicable use case | Comment |
|---------------------------------|--|------|------------|--------------------|-------------------|------|---------------------------|-------------------------|--------------------------|----------|---------|----------------|----------------------|-------------------|----------------------------------|---------------------|---|
| Management SNMP Get/Set | Get/Set Messages for configuration and read out of Node parameters | UDP | Management | Downstream to node | Management System | 10 | 15 | Single event | N/A | burst | 150 | 300 | Depending on payload | 300 | 5-500 | | Small Packet Size from XXX to YYY Bytes |
| Management SNMP Trap | Trap from Node to NMS | UDP | Management | Upstream from node | Node | 10 | 15 | Single event / Periodic | Several minutes to hours | Burst | 150 | 300 | Depending on payload | 300 | 1 per node, 5-500 per master | | Small packet size from XXX to YYY Bytes |
| Management SSH | SSH session to node | TCP | Management | Bi-directional | Management system | | | Single event | N/A | burst | 50 | 100 | Depending on payload | 100 | 1 per node; occ 5 max per master | | To be determined, main direction of traffic is upstream |
| Management SW Update to node | Secure SW-update to node | TCP | Management | Downstream to node | Management system | 200 | 500 (the more the better) | Single event | Days - weeks | constant | 2000 | Up to time-out | Approx 3MB to 30 MB | Up to time-out | 1 per node, 5-500 per master | | Depending on update strategy and implementation |
| Management Certificate exchange | Exchange of certificates | TCP | Management | Bi-directional | Management system | | | Single event | | | | | | | | | When using an encrypted, certificated based data transfer, certificates can be used for each data packet or only to open and keep a (D)TLS tunnel open. |

Table I.1 – Traffic shapes for smart grid use case scenarios

| Traffic Name | Description | Type | Service | Direction | Initiator | xput | Max xput | Periodicity | Period | Shape | Avg Lat | Max Lat | Bytes trans | Max lat per trans | Num flows | Applicable use case | Comment |
|----------------------------------|--|-----------|------------|--------------------|-------------------|------|----------|-------------------------|--|----------|---------|--------------------------|-------------|--------------------------|------------------------------|---------------------|---|
| Management Ping | Ping of nodes and/or devices connected to nodes | ICMP | Management | Bi-directional | Management System | | | Single event / Periodic | Depends | burst | 3 to 50 | | 30 - 1508 | | | | Small packets, best lat required |
| Management Data rate measurement | Iperf or similar tool | TCP / UDP | Data | Depending | Iperf application | | | Single event | N/A | constant | | | | | | | How should g.hn handle measurements? |
| Meter reading data | Reading meter data from smart meter pushing meters (e.g. wireless M-bus) | TCP | Data | Upstream from node | Node | | | Periodic | seconds to more than 15 minutes depending on meter | burst | 1000 | 2000 | <2000 | 2000 | 1 per node, 5-500 per master | | Meters with battery driven meter modules send data rarely. Electricity meters send more often. Period is normally fix |
| Meter reading command | Polls meter to send date | TCP | Data | Downstream to node | Management system | | | | | | | | <1000 | | | | |
| Meter reading data | Reading meter data from smart meter polled meters (e.g., RS-485) | TCP | Data | Upstream from node | Node | | | Periodic | Depending on needed granularity | burst | | up to needed granularity | <2000 | up to needed granularity | 1 per node, 5-500 per master | | MDM system calls meter to read out desired values |

I.1 WAN use cases (WUCs)

– WUC 1: Operating use cases

This group of WAN use cases includes management and admin services, SMGW-admin service calling, alerting and notification, and wake-up service. The use cases of WUC 1 are given as:

- WUC 1.1 Device management: SMGW-admin registers the devices connected to the SMGW and assigns them to a final consumer.
- WUC 1.2 Client administration: SMGW-admin creates, processes or deletes the final consumer in the SMGW and sets up relevant certificates or user ID / password or deletes them.
- WUC 1.3 Profile management: SMGW-admin inserts meter, communication and evaluation profiles in the SMGW and activates or deletes them.
- WUC 1.4 Key / Certificate Management: SMGW-Admin carries key and certificate for the communication with the SMGW, controllable local systems (CLS), and external market participants (EMP). It activates, deactivates or deletes keys and certificates as well.
- WUC 1.5 Firmware update: SMGW admin must be able to upload new firmware to the SMGW, to verify and activate it.
- WUC 1.6 Wake-up configuration: The SMGW-admin must be able to configure the address of the wake-up service in the SMGW.
- WUC 1.7 SMGW Monitoring: The SMGW-admin must be able to query the state of the SMGW and read out log entries from the system and calibration log.
- **WUC 2: SMGW-admin services**

The importance of this use case is the time synchronization. It synchronizes the local real-time clock in the SMGW with the time server and the SMGW-admin. For this purpose, the network time protocol (NTP) is used, which largely compensates the runtime of the packets for synchronization and thus decouples the accuracy of the synchronization of transmission latencies.

- WUC 2.1 Time synchronization: The SMGW must synchronize its system time with a trusted time service at the SMGW-admin.
- WUC 2.2 Firmware download: The SMGW can invoke a service on the SMGW-admin to download new firmware.
- WUC 2.3 Delivery of tariffed measured values or network status data: The SMGW must be able to use a service with the SMGW-admin to deliver encrypted data packages of tariffed measured values or network status data to the SMGW-admin.
- **WUC3: Alarms and messages**

The SMGW sends event or error messages to the SMGW-admin for analysis and processing (WUC 3.1). Similarly, the SMGW can send regular notifications (Alive message) to the SMGW-admin (WUC 3.2). These are typical applications in regular operation.

– WUC 4: Online access to SMGW

It deals with access to SMGW-admin to provide information about:

- The actual energy consumption and the actual usage time.
- Billing information and associated billing-relevant measured value.
- Historical energy consumption values corresponding to the periods of billing.
- Stored data for access.

– **WUC 5: Measurement data transmission**

The transmission of measurement data is summarized under WUC 5.

- WUC 5.1 Regular delivery of tariffed measured values: According to an evaluation and communication profile, the SMGW must be able to regularly deliver billing-relevant measured values for classification to an authorized EMP.
- WUC 5.2 Regular network status delivery: The SMGW must be able to regularly send network status data to an EMP according to an evaluation and communication profile.
- WUC 5.3 Spontaneous measurement reading: The spontaneous reading is done by the SMGW-admin that brings a corresponding evaluation and communication profile into the SMGW.
- **WUC 6: Communication EMP with CLS**

The SMGW must support the communication between an EMP and a CLS device in the HAN using the transport layer security (TLS) proxy functionality of the SMGW. The WUC 6 is divided into two sub-applications depending on the time requirements, namely, noncritical applications (WUC 6.1) and critical applications (WUC 6.2).

– **WUC 7: Wake-up service**

A TLS channel between SMGW and SMGW-admin is initiated by the SMGW. The SMGW-admin must be able to request the establishment of a TLS channel for the communication scenario via a wake-up service.

Table I.2 describes the communication requirements for data transmission over smart metering for the for the German.

Table I.2 – Communication requirements for data transmission over the German smart metering

| Traffic Name | Description | Type | Service | Direction | Initiator | xput | Max xput | Periodicity | Period (per year) | Shape | Avg Lat | Max Lat | Bytes trans | Max lat per trans | Num flows | Applicable Use case | Comment |
|--------------|--|------|---------|---------------|-----------|------|----------|-------------|-------------------|-------|---------|---|-------------|-------------------|--|---------------------|---|
| WUC 1.1 | Device Management | TCP | - | DL | - | - | - | - | 0.2 | - | - | 1 min | 8000 | - | Due to TLS channels, only unicast transmission. Multicast is not allowed in Germany! | - | Due to TCP requirements, 80Byte in UL |
| WUC 1.2 | Client Administration | TCP | - | DL | - | - | - | - | 0.33 | - | - | 1 min | 8000 | - | | - | Due to TCP requirements, 80Byte in UL |
| WUC 1.3-1 | Profile Management: Meter | TCP | - | DL | - | - | - | - | 0.2 | - | - | 1 min | 8000 | - | | - | Due to TCP requirements, 80Byte in UL |
| WUC 1.3-2 | Profile Management: Communication Profiles | TCP | - | DL | - | - | - | - | 592 | - | - | 1 min | 8150 | - | | - | Due to TCP requirements, 82Byte in UL |
| WUC 1.3-3 | Profile Management: Evaluation Profiles | TCP | - | DL | - | - | - | - | 412 | - | - | 1 min | 8150 | - | | - | Due to TCP requirements, 82Byte in UL |
| WUC 1.4 | Key / Certificate Management | TCP | - | Bidirectional | - | - | - | - | 0.5 | - | - | 1 min | 8000 | - | | - | UL=DL |
| WUC 1.5-1 | Firmware Upgrade: Replacement | TCP | - | DL | - | - | - | - | 1 | - | - | 3 hours each node / 3 days for complete Network | 12000000 | - | | - | Due to TCP requirements, 120KByte in UL |
| WUC 1.5-2 | Firmware Update: Patch | TCP | - | DL | - | - | - | - | 2 | - | - | 1 hour each node / 24h for complete network | 1000000 | - | | - | Due to TCP requirements, 10KByte in UL |
| WUC 1.6 | Wake-up Configuration | TCP | - | DL | - | - | - | - | 0.33 | - | - | 1 min | 8000 | - | | - | Due to TCP requirements, 80Byte in UL |
| WUC 1.7-1 | Monitoring: Status Log | TCP | - | UL | - | - | - | - | 1 | - | - | 5 min | 8000 | - | | - | Due to TCP requirements, 80Byte in DL |
| WUC 1.7-2 | Monitoring: Calibration Log | TCP | - | UL | - | - | - | - | 1 | - | - | 5 min | 10000 | - | | - | Due to TCP requirements, 100Byte in DL |
| WUC 1.7-3 | Monitoring: System Log | TCP | - | UL | - | - | - | - | 1 | - | - | 5 min | 100000 | - | | - | Due to TCP requirements, 1KByte in DL |

Table I.2 – Communication requirements for data transmission over the German smart metering

| Traffic Name | Description | Type | Service | Direction | Initiator | xput | Max xput | Periodicity | Period (per year) | Shape | Avg Lat | Max Lat | Bytes trans | Max lat per trans | Num flows | Applicable Use case | Comment |
|--------------|--|------|---------|---------------|-----------|------|----------|-------------|-------------------|-------|---------|---------|-------------|-------------------|-----------|---------------------|---------------------------------------|
| WUC 2.1-1 | Time synchronization: Call (NTP-TLS) | TCP | - | Bidirectional | - | - | - | - | 183 | - | - | <9 s | 5000 | - | - | - | UL=2/3 DL |
| WUC 3.1 | Alarm: Event and Error Message | TCP | - | UL | - | - | - | - | 10 | - | - | 1 min | 20 | - | - | - | - |
| WUC 3.2 | Alarm: Alive Messages | TCP | - | UL | - | - | - | - | 365 | - | - | 1 day | 8566 | - | - | - | Due to TCP requirements, 86Byte in DL |
| WUC 4.1 | Transfer to SMGW-admin | TCP | - | UL | - | - | - | - | 0 | - | - | 1 day | 100000 | - | - | - | Due to TCP requirements, 1KByte in DL |
| WUC 4.2 | Billing Tariff Information | TCP | - | UL | - | - | - | - | 0 | - | - | 1 day | 100000 | - | - | - | Due to TCP requirements, 1KByte in DL |
| WUC 4.3 | Historical Energy Consumption | TCP | - | UL | - | - | - | - | 0 | - | - | 1 day | 100000 | - | - | - | Due to TCP requirements, 1KByte in DL |
| WUC 4.4 | Historical D, W, M and A Energy Consumption | TCP | - | UL | - | - | - | - | 0 | - | - | 1 day | 100000 | - | - | - | Due to TCP requirements, 1KByte in DL |
| WUC 4.5 | Information from § 53 Paragraph 1 No. 1 MsbG | TCP | -- | UL | -- | -- | -- | -- | 0 | -- | -- | 1 day | 100000 | -- | -- | -- | Due to TCP requirements, 1KByte in DL |
| WUC 5.1-1 | Regular Transmission to EMP: Individual Values | TCP | - | Bidirectional | - | - | - | - | 0 | - | - | <15 min | 10000 | - | - | - | UL=1/5 DL |
| WUC 5.1-2 | Regular Transmission to EMP: Load and Meter Readings | TCP | - | Bidirectional | - | - | - | - | 830 | - | - | <15 min | 10000 | - | - | - | UL=1/5 DL |
| WUC 5.2 | Regular Transmission to EMP: Network States | TCP | - | Bidirectional | - | - | - | - | 0 | - | - | <1 min | 10000 | - | - | - | UL=1/5 DL |
| WUC 5.3-1 | Spontaneous Reading: Individual Values | TCP | - | Bidirectional | - | - | - | - | 0 | - | - | 1 min | 10000 | - | - | - | UL=1/5 DL |
| WUC 5.3-2 | Spontaneous Reading: Load and Smart Reading | TCP | - | Bidirectional | - | - | - | - | 41 | - | - | 10 min | 10000 | - | - | - | UL=1/5 DL |

Table I.2 – Communication requirements for data transmission over the German smart metering

| Traffic Name | Description | Type | Service | Direction | Initiator | xput | Max xput | Periodicity | Period (per year) | Shape | Avg Lat | Max Lat | Bytes trans | Max lat per trans | Num flows | Applicable Use case | Comment |
|--------------|--|------|---------|---------------|-----------|------|----------|-------------|-------------------|-------|---------|---------|-------------|-------------------|-----------|---------------------|--------------------------------------|
| WUC 5.3-3 | Spontaneous Reading: Grid Conditions | TCP | - | Bidirectional | - | - | - | - | 250 | - | - | 1 min | 10000 | - | | - | UL=1/5 DL |
| WUC 6.1 | Communication EMP with CLS: § 14a | TCP | - | Bidirectional | - | - | - | - | 200 | - | - | <10 min | 10000 | - | | - | UL=DL |
| WUC 6.2 | Communication EMP with CLS: from Attachments | TCP | - | Bidirectional | - | - | - | - | 100 | - | - | <1 min | 10000 | - | | - | UL=DL |
| WUC 7 | Wake-up Service | TCP | - | UL | - | - | - | - | 760 | - | - | <30 s | 136 | - | | - | Due to TCP requirements, 1Byte in DL |