

RECOMMENDATION 715*

INTERNATIONAL EXCHANGE OF ENG RECORDINGS

(1990)

The CCIR,

CONSIDERING

- (a) that Electronic News Gathering (ENG) is widely used in broadcasting in several parts of the world;
- (b) that videotape recording is a fundamental element in ENG operation;
- (c) that it would be beneficial to broadcasters in their ENG recording operation if common ENG interface standards, recording formats and operating practices were adopted in the world; while a variety of standards would be wasteful and impede the international exchange of ENG recordings and, possibly the compatibility of equipment,

UNANIMOUSLY RECOMMENDS

1. that in order to facilitate the interconnection of ENG equipment of different models, uniform interfaces should preferably be used in ENG equipment; it is noted that, in the case of analogue component ENG equipment, an EBU Recommendation exists for the camera-to-VTR interface (see Annex I) and an EBU standard exists for the parallel analogue component video interface (see Annex II);
2. that in order to facilitate the international exchange of ENG recordings, uniform ENG recording formats should preferably be used; it is noted that the format presently still used in several European countries for analogue composite ENG recording is described in EBU Document Tech. 3233 (July, 1980): "ENG helical-scan video cassette system using 19 mm (3/4 in) tape (U-matic H format)"; and that the EBU has recommended to its members that, for electronic news gathering equipment using analogue component signals, they should use the recording format described in IEC Publication 961, i.e., format L (so-called BETACAM system) presently under examination by the IEC, the EBU Recommendation has the reference R32-1984;
3. that, in order to facilitate the use of exchanged ENG recordings, the operating guidelines shown in Annex III should be followed;
4. that, in order to preserve picture quality in international exchange of ENG recordings, at the present state of technology, only recordings of generations not greater than the second (that is, the first copy from the original) should preferably be offered for international exchange, when 19 mm (3/4 in) ENG video tape recordings (VTR) are used: when using analogue component ENG VTR machines of format L, if the signal remains in the analogue component domain, recordings of up to the third generation may be used, and certainly not more than the fourth;
5. that, in order to facilitate the use by receiving organizations, of programmes originated from ENG recordings and relayed over transmission facilities, the guidelines described in Annex IV should preferably be followed.

Note – Normally, ENG tape recordings can undergo several further generations of copying by full-broadcast quality VTR machines, without significant deterioration in picture quality.

* This Recommendation should be brought to the attention of the IEC, Broadcasting Unions and the SMPTE.

EBU TECHNICAL RECOMMENDATION R34

INTERFACE FOR THE INTERCONNECTION OF ENG CAMERAS AND PORTABLE VTRs
USING NON-COMPOSITE SIGNALS

This interface is designed to enable the ENG signals produced in a non-composite form to be sent through a parallel link between a camera and a portable VTR which are separated by about 5 to 10 metres, instead of being combined in a "camcorder".

The specification includes the electrical characteristics that the interface must satisfy in order to transmit the programme signals produced by the camera (audio and video components) and those fed back to the viewfinder (video playback), as well as the operational controls and the monitoring indications. The specification includes only those characteristics considered to be essential to facilitate the interconnection of equipment produced by different manufacturers. In order to prevent damage due to incorrect connections, it is necessary to make sure that the equipment concerned complies with these specifications, and furthermore that the additional connections provided by the manufacturers in the case of particular systems are not incompatible with these specifications.

One system has been recommended by the EBU for the production of non-composite ENG signals (Recommendation R32). The detailed specification of the interface for this system is given in an annex to Recommendation R32, and the correspondences between the contacts in that case and the signals taken into account by the EBU are indicated.

1. Electrical characteristics of the interface**1.1 Programme signals**

In practice, component video signals are generally designated by the letters Y , $R-Y$, and $B-Y$, but in the following the notation adopted by the CCIR has been used: E'_Y , E'_{CR} and E'_{CB} .

Luminance signal (camera → VTR)

The luminance signal is the same as that defined in CCIR Report 624-2. In accordance with Table II of that Report, it is obtained from the primary signals by means of the equation:

$$E'_Y = 0.299 E'_R + 0.587 E'_G + 0.114 E'_B$$

where E'_R , E'_G and E'_B are the primary signals after gamma pre-correction. In the present application, the amplitude range of the primary signals is 0.700 V.

The luminance signal should include synchronizing pulses and line and field blanking in accordance with CCIR Report 624-2 (Tables I, I.1 and I.2).

The amplitude of this signal should comply with the following specifications:

Peak-to-peak amplitude (including sync.):	1 V
Nominal value of the d.c. component:	0 V at blanking level or a.c. coupled output
Input and output impedance:	$Z_o = Z_i = 75 \Omega$.

Colour-difference signals (camera → VTR)

The colour-difference signals are obtained from the E'_Y signal and the primary signals specified above. When the amplitude range of the primary signals is 0.7 V, the colour-difference signals comply with the following equations, which are the same as those given in the CCIR Report 629-2:

$$E'_{CR} = 0.713 (E'_R - E'_Y)$$

$$E'_{CB} = 0.564 (E'_B - E'_Y)$$

Both these signals should include line and field blanking in accordance with CCIR Report 624-2 (Tables I, I.1 and I.2). Neither of them should include sync. pulses.

The amplitude of the E'_{CR} and E'_{CB} signals should comply with the following specifications:

Peak-to-peak amplitude:	0.700 V for 100/0/100/0 colour bars. 0.525 V for 100/0/75/0 colour bars
Nominal value of the d.c. component:	0 V at blanking level or a.c. coupled output.
Input and output impedance of the interface:	$Z_o = Z_i = 75 \Omega$.

All three signals E'_Y , E'_{CR} and E'_{CB} should be simultaneous in real time and convey time-coincident information.

Their characteristics are illustrated in Fig. 1.

The specification does not include any band-limitation for the luminance or colour-difference signals; if necessary, in order to ensure that the equipment operates correctly, such limitation should be applied at the input stages of the equipment.

The insertion of signals during the field-blanking period is reserved by the EBU. The use of lines 12/325 in the E'_{CR} and E'_{CB} signals to identify the colour fields in the case of preliminary composite processing is, however, under study. The use of other lines in all three signals to carry an amplitude and phase reference is under study.

Playback video signal (VTR → camera)

The specifications applicable to this signal are as follows:

Peak-to-peak amplitude (including sync.):	1 V
Nominal value of the d.c. component:	0 V at blanking level or a.c. coupled input
Input and output impedance:	$Z_o = Z_i = 75 \Omega$.

A manual switch may be provided on the camera to route this signal to the viewfinder, but it is also possible to provide an automatic switch, the control of which is transmitted through the interface from the VTR. Such a system does not form part of this specification. However, if both automatic and manual switches are provided, the latter should be able to force the viewfinder to show the camera picture, whatever control signal is received from the VTR.

Audio signal (camera → VTR)

The signal produced by the microphone should comply with the following specification:

Level ≥ -60 dBu, balanced.
$Z_o = 200 \Omega$ $Z_i = 3$ to $10 \text{ k}\Omega$.

1.2 *Power supply (VTR → camera)*

Voltage (at the output of the VTR):
12 V nominal (minimum: 10.6 V, maximum: 17 V).

The camera should be able to operate with the power supply provided by the VTR, taking account of the voltage reduction due to the supply cable. However, in order to make allowance for the case of cameras having their own battery, arrangements should be made in the camera to automatically prevent the interconnection of the battery in it with that in the VTR.

1.3 *VTR start/stop control*

The start/stop control for the VTR should comply with the following specification:

Start: 5 V nominal (4 to 8 V, CMOS).
Stop: 0 V nominal (0 to 0.5 V, CMOS).

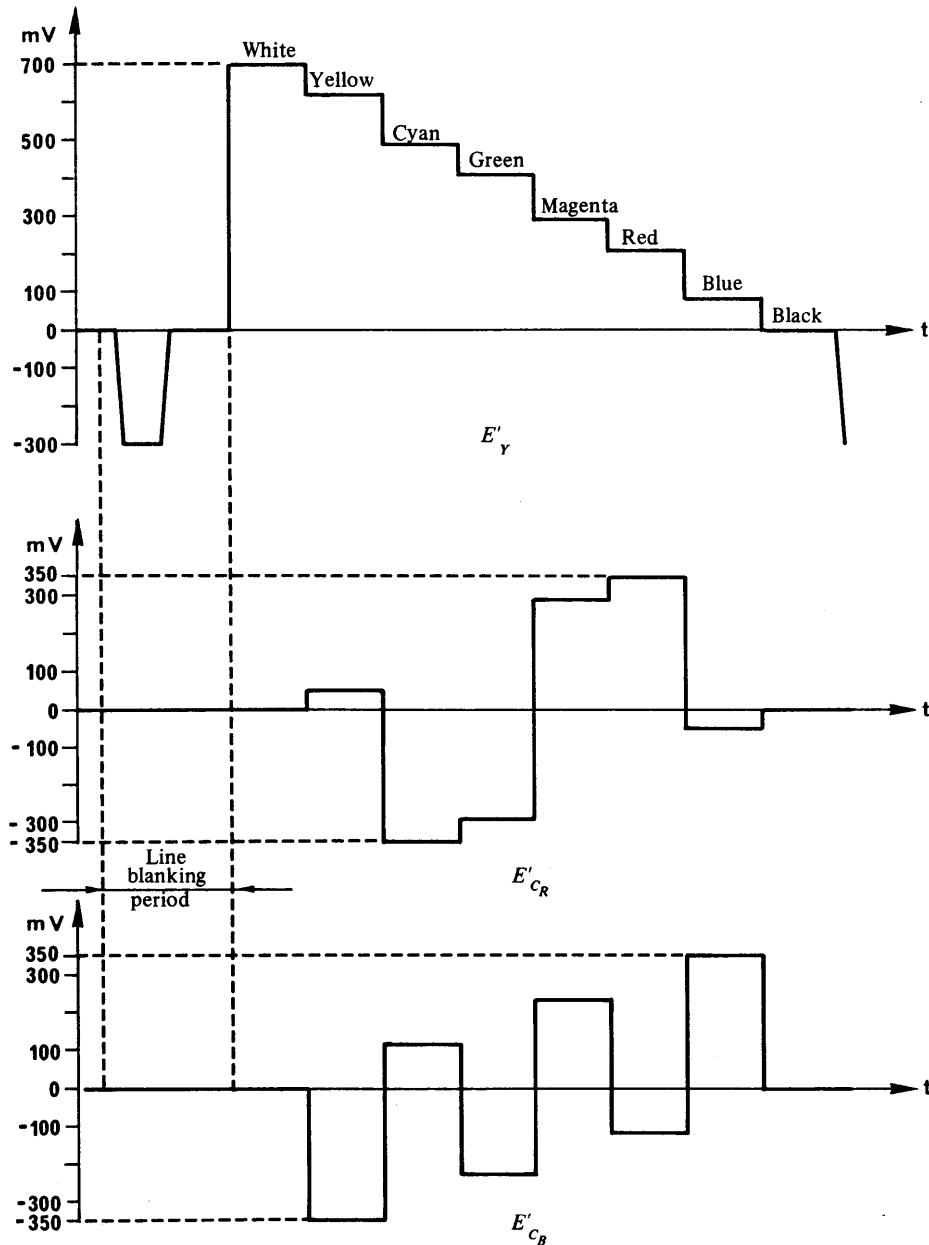

FIGURE 1 – Waveform of video signals for 100/0/100/0 colour bars

D01-sc

1.4 Indication of recording/VTR fault

The appearance of this signal is shown in Fig. 2.

The specifications of this signal are as follows, with an input impedance of $Z_i = 20 \text{ k}\Omega$:

Recording in progress: 5.0 V nominal (4.5 to 6.0 V).

Recording halted: 2.5 V nominal (2.0 to 3.0 V).

VTR disconnected: 0 V nominal (0 to 0.3 V).

VTR fault: alternating 5.0 V/2.5 V (with the same tolerances as given above).
 Duty cycle: 50% nominal (40 to 60%).
 Frequency: 1 Hz nominal (0.8 to 1.2 Hz).

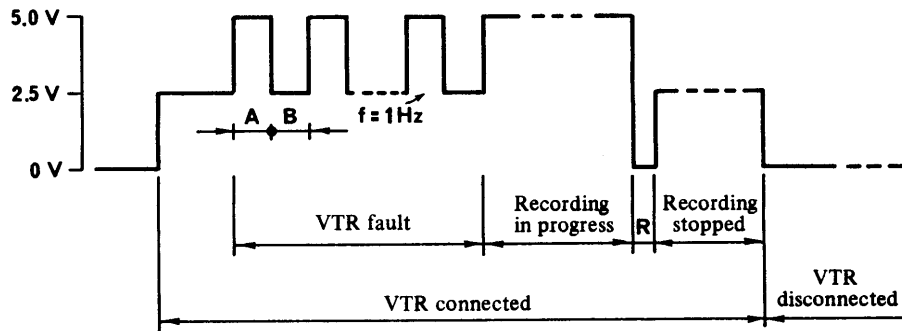

FIGURE 2 – Indication of recording/VTR fault

D02-sc

Note – The transition from signal “Recording in process” to signal “Recording stopped” is unambiguously defined by the R (“Record reset”) pulse.

$$\frac{A}{A+B} = 50 \pm 10\% \quad R = 10 \text{ to } 100 \text{ ms}$$

This signal indicates, at the camera, whether the VTR is recording or not, and also provides information on its operating state. The interface does not make provision for particular warnings (e.g. battery discharged). All the warnings generated by the system concerned are transmitted by the same signal. Various individual alarms can also be provided at the camera, but they are not covered by this specification.

The other signals (e.g. other audio inputs to the VTR or reference video signals for locking the camera’s sync. pulse generator) should be connected by means of special sockets on the camera or VTR. They are not covered by this specification, and neither is the composite video interface that may be found on equipment of this type.

2. Characteristics of the connector

It is not considered necessary to specify a special connector for this interface, as manufacturers are using different models for the interconnection of their equipment. The importance of this specification lies in the characteristics of the signals which make it possible to provide interfaces between items of equipment that would otherwise be incompatible.

ANNEX II

EBU TECHNICAL STANDARD N10

PARALLEL COMPONENT VIDEO INTERFACE FOR NON-COMPOSITE ENG SIGNALS

This interface is designed to enable component video signals to be carried by parallel interconnections between ENG VTRs and other equipment that may be found in ENG post-production installations using component signals*.

This specification does not cover the interface needed for the connection of the audio and auxiliary signals (time-and-control code, remote control, etc.), nor does it deal with the interfaces for composite video signals that are sometimes provided in equipment of this type.

* For copying, but no other purpose, a different interface may be used if necessary (such an interface must not be used for other applications, as it will depend on the format).

1. Types of signal carried by the interface

Three separate connectors should be provided to carry the following components of the video signal:

- luminance signal (with sync.),
- red colour-difference signal (without sync.),
- blue colour-difference signal (without sync.).

In practice, these signals are generally represented by the symbols Y , $R-Y$ and $B-Y$, but in the following the notation adopted by the CCIR has been used: E'_Y , E'_{CR} and E'_{CB} .

2. Waveform of the signal

The luminance signal E'_Y should include sync. pulses and line and field blanking in accordance with CCIR Report 624-2 (Tables I, I.1 and I.2).

The two colour-difference signals E'_{CR} and E'_{CB} should include line and field blanking in accordance with CCIR Report 624-2 (Tables I, I.1 and I.2). Neither of them should include sync. pulses.

All three signals (E'_Y , E'_{CR} and E'_{CB}) should be simultaneous in real time and carry time-coincident picture information.

The insertion of signals in the field-blanking period is reserved by the EBU. The use of lines 12/325 of the E'_{CR}/E'_{CB} signals for the identification of the colour fields in the case of preliminary composite processing is, however, under study. The use of other lines in the three signals to convey amplitude and phase reference signals is under study.

3. Electrical characteristics of the interface

3.1 Luminance

The luminance signal is the same as that obtained in CCIR Report 624-2. In accordance with Table II of that Report, it is obtained from the primary signals by means of the equation:

$$E'_Y = 0.299 E'_R + 0.587 E'_G + 0.114 E'_B$$

where E'_R , E'_G and E'_B are the primary signals after gamma pre-correction. In this application, the amplitude range of the primary signals is 0.700 V.

The amplitude of the E'_Y signal should comply with the following specifications:

Peak-to-peak amplitude (including sync.): 1 V

Nominal value of the d.c. component: 0 V at blanking level or a.c. coupled output.

Input and output impedances of the interface:

$$Z_o = 75 \Omega \quad Z_i = 75 \Omega$$

These characteristics of the signals are shown in Fig. 1.

3.2 Colour-difference signals

The colour-difference signals are obtained from the E'_Y signal and the primary signals specified above. When the amplitude range of these signals is 0.7 V, the colour-difference signals comply with the following equations, which are the same as those given in CCIR Report 629-2:

$$E'_{CR} = 0.713 (E'_R - E'_Y)$$

$$E'_{CB} = 0.564 (E'_B - E'_Y)$$

The amplitude of the signals E'_{CR} and E'_{CB} should comply with the following specification:

Peak-to-peak amplitude: 0.700 V for 100/0/100/0 colour bars.

0/525 V for 100/0/75/0 colour bars.

Nominal value of the d.c. component: 0 V at blanking level or a.c. coupled output.

Input and output impedances of the interface:

$$Z_o = 75 \Omega \quad Z_i = 75 \Omega$$

Neither of these signals includes sync. pulses, but both include clamping periods.

The characteristics of the signals are shown in Fig. 1.

3.3 The specification does not require any limitation of the pass-band; if necessary, such limitation should be applied in the input stages of the equipment.

4. Mechanical characteristics

The interface takes the form of type BNC connectors, with the female part mounted on VTRs and other equipment.

ANNEX III

OPERATING GUIDELINES FOR THE INTERNATIONAL EXCHANGE OF ENG RECORDINGS

1. Allocation of audio tracks

All the prevailing types of ENG recorders have two (or more) audio tracks. When only one programme sound signal is recorded with the programme material, this should be on the most protected audio track (e.g. a track away from the edge of the tape rather than a track on the edge of the tape).

2. Information on the recording label

Suitable information should be provided, preferably on a label affixed to the tape cassette or tape reel as appropriate, to identify the content of exchanged ENG recordings. However, in the case of ENG recordings it does not seem essential to provide all the programme information described in Recommendation 469, § 8.1. It appears that only the following information is really necessary:

- name of organization which originated the recording,
- programme number or cassette number,
- location of each event,
- date of each event,
- subject of each event and shot list,
- playing time of each event,
- recording format,
- television standard,
- content of audio tracks.

The same information should also be provided on a label affixed to the tape or cassette container.

3. Identification of different shots on a recorded ENG video cassette

When several shots of the same event are included in an ENG recording their location on the tape can be identified by means of the tape counter, provided that care is taken to reset the tape counter to zero at the start of the tape. Alternatively, the location of the shots on the tape can be identified by means of the time and control code, if used.

ANNEX IV

GUIDELINES FOR THE INTERNATIONAL EXCHANGE OF PROGRAMMES ORIGINATED
FROM ENG RECORDINGS

ENG pictures carried across national boundaries for international exchange should be suitable for direct broadcasting, for standards conversion, for transcoding, or for recording on full-broadcast quality machines, without any additional timing corrections. If this is not the case, broadcasters must reprocess the signal, perhaps through a digital time-base corrector, since it is not easy to tell, with normal monitoring equipment, whether the ENG signals are suitable for broadcasting purposes; however, continued reprocessing of the ENG signal is not only wasteful of equipment time, but steadily reduces the picture quality.

Such ENG pictures should, in principle, conform to one of the standards in Report 624 "Characteristics of television systems" and, for 625-line systems, Recommendation 472, "Video-frequency characteristics of a television system to be used for the international exchange of programmes between countries that have adopted 625-line colour or monochrome systems". However, for such purposes, a video bandwidth smaller than the usual value may be admitted during the initial stage.

Any equipment for noise reduction or image improvement should be sited as close to the source of degradation as is practicable.

Repeated processing of the ENG signal should be avoided as far as possible, since it is likely to steadily reduce the picture quality.
