

RECOMMENDATION ITU-R BT.1358

**STUDIO PARAMETERS OF 625 AND 525 LINE PROGRESSIVE
SCAN TELEVISION SYSTEMS**

(Question ITU-R 1-3/11)

(1998)

The ITU Radiocommunication Assembly,

considering

- a) that there is interest in using progressive scan systems as input to enhanced analogue services and for digital television broadcasting;
- b) that the progressive signal offers improved vertical and temporal resolution over the conventional interlaced signal;
- c) that parameter values for the progressive systems should have maximum commonality with the existing conventional television and high-definition television systems;
- d) that progressive systems can be scaled up from conventional interlaced 625 and 525 line systems;
- e) that progressive systems can be scaled down from high-definition television systems which will embody internationally agreed unified colorimetric parameters;
- f) that the above two approaches could lead to systems with different parameters, for example colorimetry and synchronizing waveforms;
- g) that a scaled up 525 line system is already used as source for EDTV II,

recommends

1 that the following parameters derived from conventional interlaced television systems be used for 625 and 525 line progressive scan television systems.

NOTE – 625 and 525 line progressive scan television systems are still under study, in particular, those derived from high-definition television (HDTV) systems. These systems should be considered for inclusion in the Recommendation when they are developed.

ANNEX 1

Signal parameter values for 625/50/1:1 and 525/59.94/1:1 progressive scanning systems derived from conventional 625 and 525 line standards

1 Opto-electronic conversion

Item	Parameter	Characteristics			
		625/50/1:1		525/59.94/1:1	
1.1	Chromaticity coordinates, CIE 1931 ⁽¹⁾	<i>x</i>	<i>y</i>	<i>x</i>	<i>y</i>
	Primaries Red	0.640	0.330	0.630	0.340
	Green	0.290	0.600	0.310	0.595
	Blue	0.150	0.060	0.155	0.070
1.2	Assumed chromaticity for equal primary signals - Reference white	D_{65}			
		<i>x</i>		<i>y</i>	
	$E_R = E_G = E_B$	0.3127		0.3290	
1.3	Opto-electronic transfer characteristics before non-linear precorrection	Assumed linear			
1.4	Overall opto-electronic transfer characteristic at source	$E = (1.099 L^{0.45} - 0.099)$ for $1.00 \geq L \geq 0.018$ $E = 4.500 L$ for $0.018 > L \geq 0$ where: L : luminance of the image $0 \leq L \leq 1$ for conventional colorimetry E : corresponding electrical signal.			

⁽¹⁾ Chromaticity coordinates specified are those currently used by 625-line and 525-line conventional systems.

NOTE – See Recommendation ITU-R BT.1361, (Worldwide unified colorimetry and related characteristics of future television and imaging systems).

2 Picture and scanning characteristics

Item	Parameter	Characteristics	
		625/50/1:1	525/59.94/1:1
2.1	Order of scanning	Left to right, top to bottom	
2.2	Scanning format	Progressive 1:1	
2.3	Picture rate (Hz)	50	60/1.001
2.4	Total number of lines	625	525
2.5	Active lines per picture	576 (lines 45 - 620)	483 (line 43 - 525)
2.6	Aspect ratio ⁽¹⁾	16:9 (4:3)	
2.7	Line frequency (Hz)	$31\,250 \pm 0.0001\%$	$31\,500/1.001 \pm 3$ ppm

⁽¹⁾ The aspect ratio for HDTV and EDTV applications will normally be 16:9. It is possible that progressive scanning systems will be used within standard TV (SDTV) applications with an aspect ratio of 4:3. Parameters for such systems are contained within standard parenthesis, i.e. (4:3).

3 Analogue representation

The terms $E'_R, E'_G, E'_B, E'_Y, E'_{P_B}$ (or E'_{C_B}), E'_{P_R} (or E'_{C_R}) refer to gamma pre-corrected analogue signals.

Levels are specified in millivolts measured across a matched 75 Ω termination.

Item	Characteristics		
	Parameter	625/50/1:1	525/59.94/1:1
3.1	Primary signals nominal level, Standard colorimetry, E'_R, E'_G, E'_B :	Reference black: 0%, 0 mV Reference peak level: 100%, 700 mV	
3.2	Derivation of luminance component signal E'_Y ⁽¹⁾	$E'_Y = 0.299 E'_R + 0.587 E'_G + 0.114 E'_B$	
3.3	Derivation of colour-difference component signals E'_{P_B}, E'_{P_R} ⁽¹⁾	$E'_{P_B} = \frac{E'_B - E'_Y}{1.772}$ $= -0.169 E'_R - 0.331 E'_G + 0.500 E'_B$ $E'_{P_R} = \frac{E'_R - E'_Y}{1.402}$ $= 0.500 E'_R - 0.419 E'_G - 0.081 E'_B$	
3.4	Component signals nominal level, Standard and extended colorimetry, Luminance E'_Y : Colour difference E'_{P_B}, E'_{P_R} :	Reference black: 0%, 0 mV Reference White: 100%, 700 mV No signal: 0%, 0 mV Maximum colour difference: $\pm 50\%$, ± 350 mV	
3.5	Nominal signal bandwidth E'_R, E'_G, E'_B, E'_Y E'_{P_B}, E'_{P_R}	12 MHz 6 MHz	
3.6	Form of synchronizing signal on primary and component signals ⁽²⁾	Bi-level bipolar (Fig. 1)	
3.7	Horizontal sync timing reference	O_H (Fig. 1)	
3.8	Sync level (mV)	-300 ± 7.5 mV	
3.9	Inter-component timing accuracy	± 10 ns	
3.10	Horizontal sync and blanking interval signal timing	Fig. 1 and Table 1	
3.11	Vertical sync and blanking interval signal timing	Fig. 2 and Tables 2 and 3	

⁽¹⁾ The luminance and colour difference encoding equations used here are those currently recommended for conventional systems.

⁽²⁾ Addition of synchronizing signal on R, B, P_B and P_R signals is optional.

FIGURE 1

Horizontal synchronizing pulse

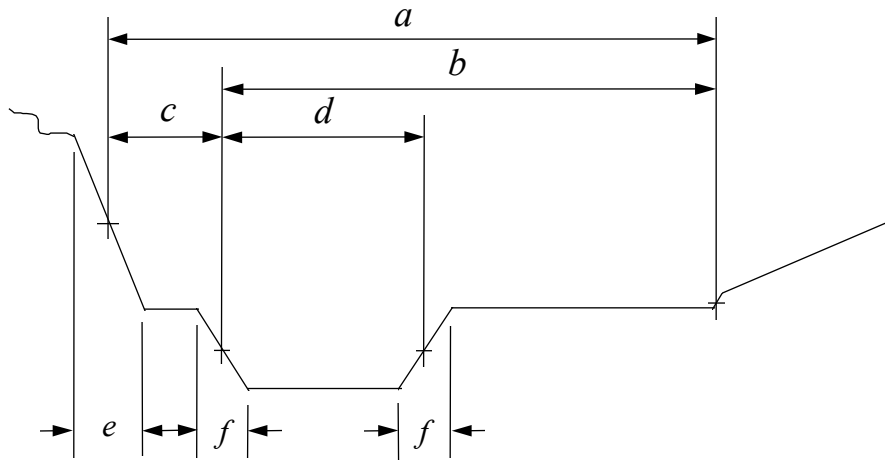

TABLE 1

Details of horizontal synchronizing signals

Symbol	Characteristics	625/50/1:1	525/59.94/1:1
H	Nominal line period (μs)	32	1001/31.5 (31.778)
<i>a</i>	Horizontal blanking interval (μs)	6.0 ± 1.5	$5.35 + 0.15$ -0.1
<i>b</i>	Interval between time datum (O_H) and back edge of horizontal blanking pulse (μs)	5.25	$4.6 + 0.1$ -0.05
<i>c</i>	Front porch (μs)	0.75 ± 0.15	0.75 ± 0.05
<i>d</i>	Synchronizing pulse (μs)	2.35 ± 0.1	2.35 ± 0.05
<i>e</i>	Build-up time (10 to 90%) of the edges of the horizontal blanking pulse (μs)	0.15 ± 0.05	0.07 ± 0.01
<i>f</i>	Build-up time (10 to 90%) of the edges of the horizontal synchronizing pulses (μs)	0.1 ± 0.05	0.07 ± 0.01

FIGURE 2

Vertical synchronizing pulses

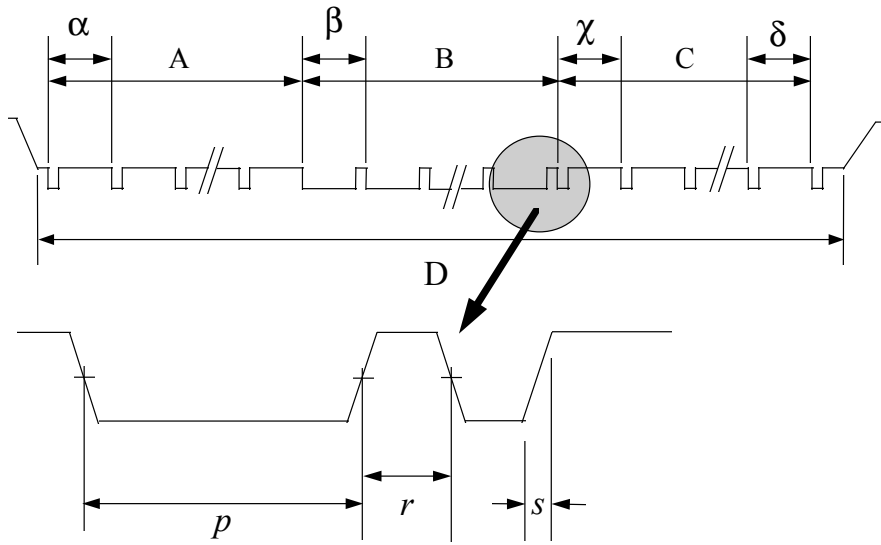

TABLE 2

Details of vertical synchronizing signals

Symbol	Characteristics	625/50/1:1	525/59.94/1:1
V	Nominal frame period (ms)	20	1001/60 (16.683)
D	Vertical blanking interval	$49H + a^{(1)}$	$42H + a^{(1)}$
–	Build-up time (10 to 90%) of the edges of vertical blanking pulse (μs)	0.15 ± 0.05	0.07 ± 0.01
A	Interval between front edge of vertical blanking interval and front edge of first vertical synchronizing pulse	$5H^{(1)}$	$6H^{(1)}$
C	Interval between back edge of last vertical synchronizing pulse and back edge of vertical blanking interval	$39H^{(1)}$	$30H^{(1)}$
B	Duration of sequence of vertical synchronizing pulses	$5H^{(1)}$	$6H^{(1)}$
p	Duration of vertical synchronizing pulse (μs)	29.65 ± 0.1	29.428 ± 0.05
r	Interval between vertical synchronizing pulse (μs)	2.35 ± 0.1	2.35 ± 0.05
s	Build-up time (10 to 90%) of the vertical synchronizing pulses (μs)	0.1 ± 0.05	0.07 ± 0.01

⁽¹⁾ For H and a , see Table 1.

TABLE 3

Vertical blanking interval line numbers

	Line number			
	α	β	χ	δ
625/50/1:1	621	1	6	44
525/59.94/1:1	1	7	13	42

4 Digital representation

The terms R , G , B , Y , C_B , C_R , refer to quantized and digitally encoded signals. These signals are obtained from gamma pre-corrected signals.

The digital representation in the following table follows Recommendation ITU-R BT.601 Part A which defines the 4:2:2 13.5 MHz standard for 4:3 and for wide-screen 16:9 aspect ratio systems. For 16:9 aspect ratio only, Recommendation ITU-R BT.601 Part B defining a higher horizontal resolution is equally valid and the appropriate values should be substituted from Recommendation ITU-R BT.601 as required.

Item	Parameter	Characteristics	
		625/50/1:1	525/59.94/1:1
4.1	Coded signal	R , G , B , or Y , C_B , C_R	
4.2	Sampling lattice R , G , B , Y	Orthogonal, line and picture repetitive	
4.3	Sampling lattice C_B , C_R	Orthogonal, line and picture repetitive, co-sited with odd (1st, 3rd, 5th, etc.) Y active samples in each line	
4.4	Sampling frequency R , G , B , Y Sampling frequency C_B , C_R	27 MHz \pm 3 ppm Half luminance sampling frequency 13.5 MHz \pm 3 ppm	
4.5	Number of samples per full line R , G , B , Y C_B , C_R	864 432	858 429
4.6	Number of samples per active line R , G , B , Y C_B , C_R	720 360	
4.7	Coding format ⁽¹⁾	Linear, 8 or 10 bits/sample for each primary and component signal	
4.8	Quantization: ⁽²⁾ Primary signals R , G , B :	$R, G, B = \text{INT} \left[(219 E'_{R, G, B} + 16) \cdot 2^{n-8} \right]$ 220 or 877 quantization levels with black level at 16 or 64 and peak white level at 235 or 940, respectively	

Item	Characteristics		
	Parameter	625/50/1:1	525/59.94/1:1
4.9	Quantization: ⁽²⁾ Component signal Y : Component signals C_B, C_R :	$Y = \text{INT} \left[(219 E'_Y + 16) \cdot 2^{n-8} \right]$ <p>220 or 877 quantization levels with black level at 16 or 64 and peak white level at 235 or 940, respectively</p> $C_B = \text{INT} \left[(224 E'_{P_B} + 128) \cdot 2^{n-8} \right]$ $C_R = \text{INT} \left[(224 E'_{P_R} + 128) \cdot 2^{n-8} \right]$ <p>225 or 897 quantization levels symmetrically disposed about zero signal at 128 or 512 respectively</p>	
4.10	Derivation of Y, C_B, C_R from quantized primary signals R, G, B : ⁽³⁾	$Y = \frac{76.50}{256} R + \frac{150.25}{256} G + \frac{29.25}{256} B$ $C_B = -\frac{44.25}{256} R - \frac{86.75}{256} G + \frac{131.00}{256} B + 128.00$ $C_R = \frac{131.00}{256} R - \frac{109.75}{256} G - \frac{21.25}{256} B + 128.00$	
4.11	Timing relationship between analogue sync reference (O_H) and video data	132 samples @ 27 MHz (Fig. 3)	122 samples @ 27 MHz (Fig. 3)
4.12	Quantization level assignment: Video data: Timing references:	<p>1.00 through 254.75 0.00 to 0.75 and 255.00 to 255.75</p>	
4.13	Filter characteristics ⁽⁴⁾ R, G, B, Y C_B, C_R	<p>Fig. 4 Fig. 5</p>	

- (1) To avoid confusion between 8-bit and 10-bit representations, the eight most-significant bits are considered to be an integer part while the two additional bits, if present, are considered to be fractional parts. For example, the bit pattern 10010001 would be expressed as 145d or 91h, whereas the pattern 1001000101 would be expressed as 145.25d or 91.4h. The fractional parts are shown here if valid, otherwise they are assumed to have the binary value 00. Levels are quoted for 8 and 10 bit quantization.
- (2) “ n ” denotes the number of the bit length of the quantized signal. The operator INT returns the value of 0 for fractional parts in the range of 0 to 0.49999.... and +1 for fractional parts in the range of 0.5 to 0.99999...., i.e., it rounds up fraction above 0.5.
- (3) Coefficients of length other than 8 or 10 may be used.
- (4) The filter templates are shown in Fig. 4 and Fig. 5 as a guideline.

FIGURE 3
Timing relationship between analogue sync reference (O_H) and video data

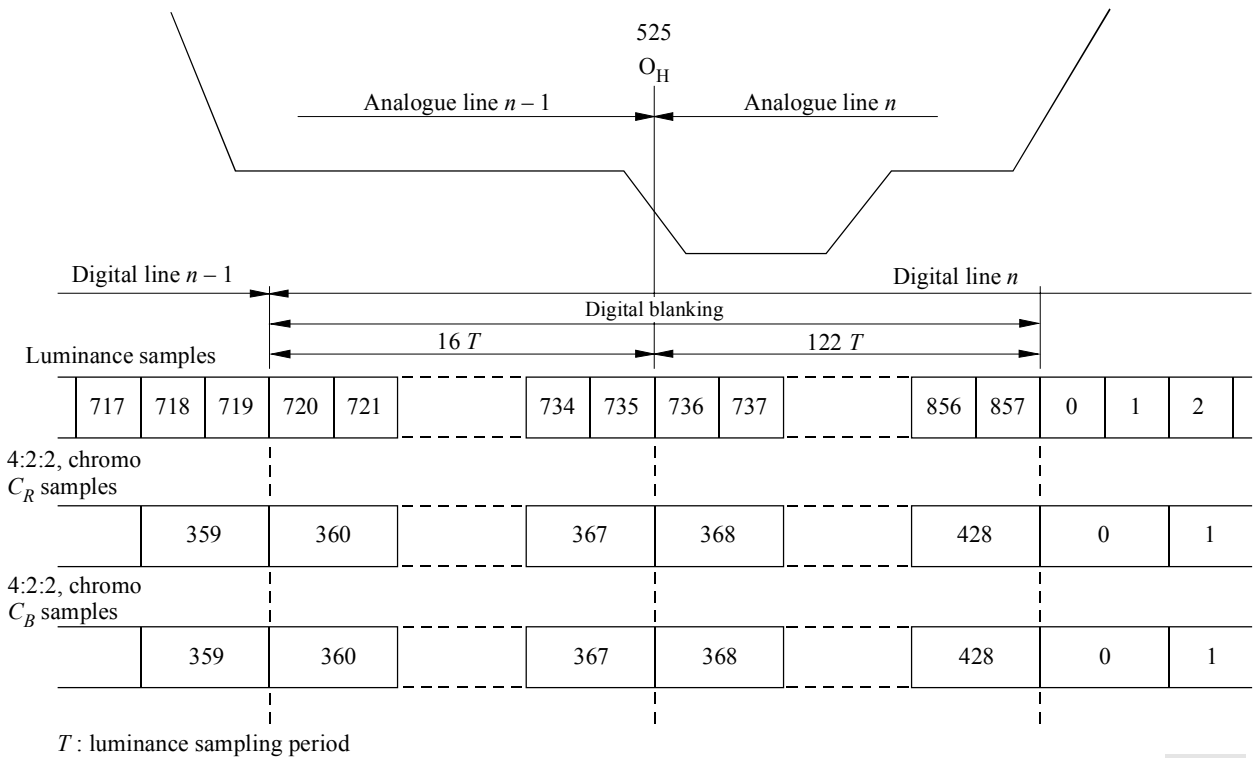
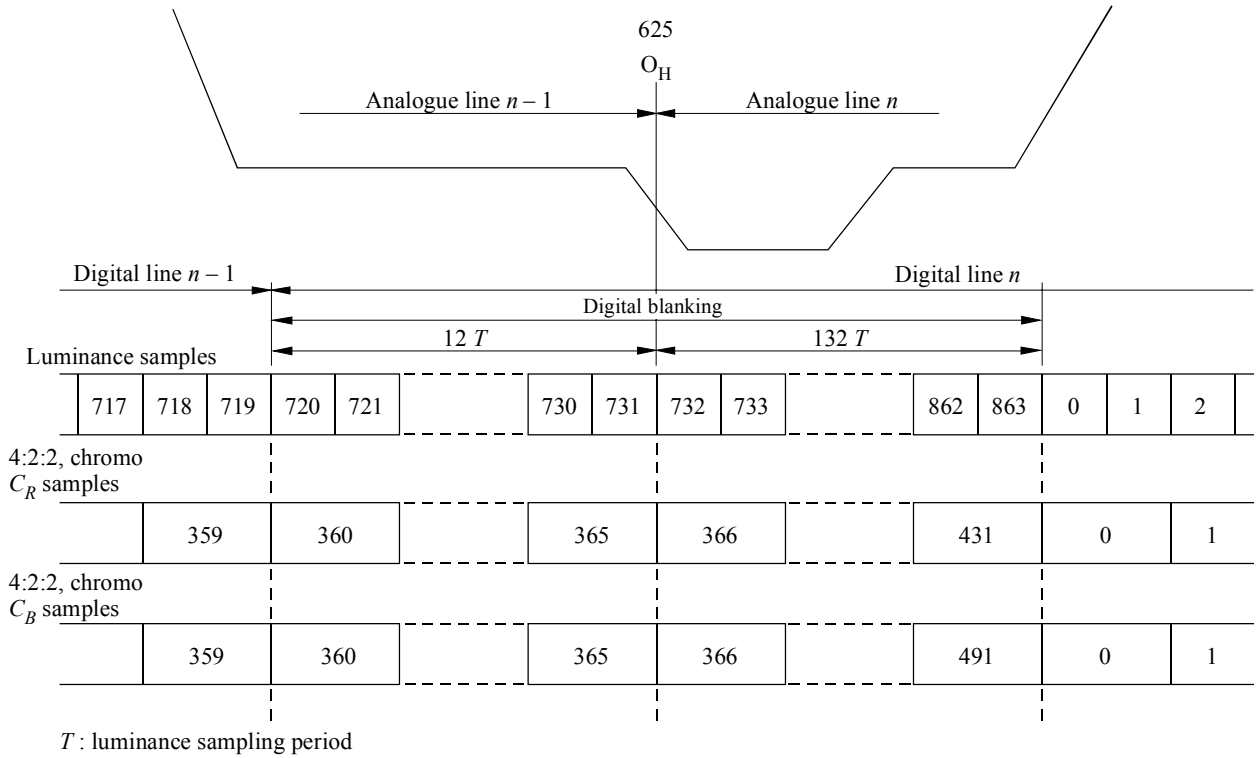
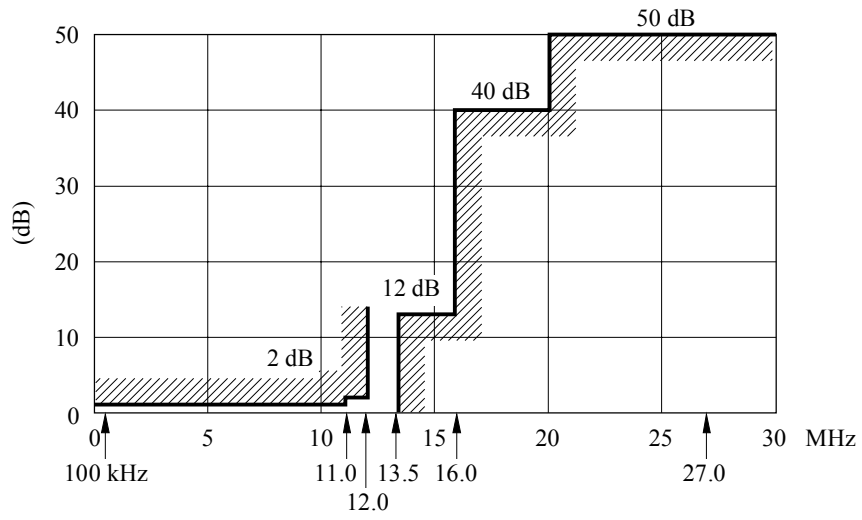
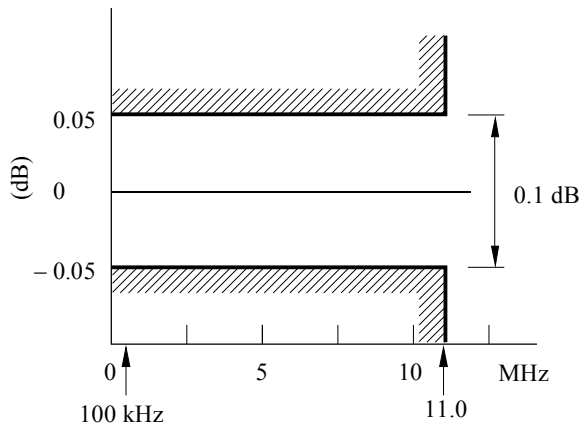

FIGURE 4
Filter templates for *R*, *G*, *B*, and *Y* signals



a) Template for insertion loss



b) Pass-band ripple tolerance

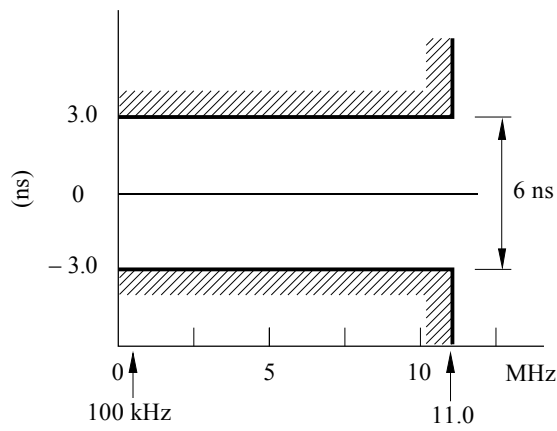

c) Passband group-delay tolerance

Note 1 – Ripple and group-delay are specified relative to values at 100 kHz.

FIGURE 5
Filter templates for P_B , P_R signals

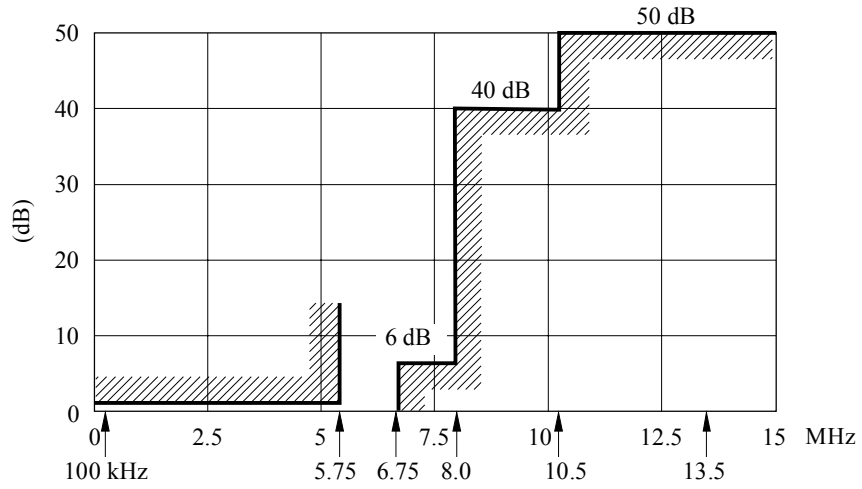

a) Template for insertion loss

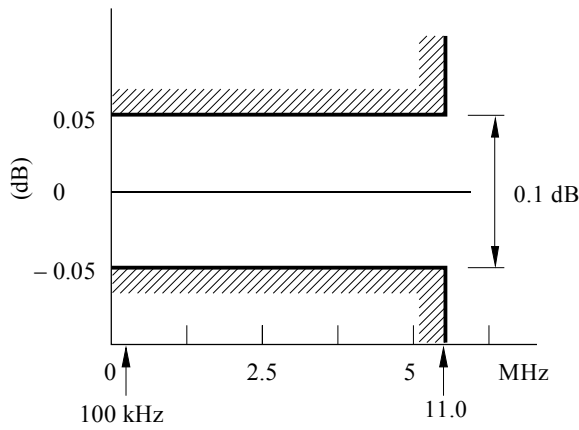

b) Pass-band ripple tolerance

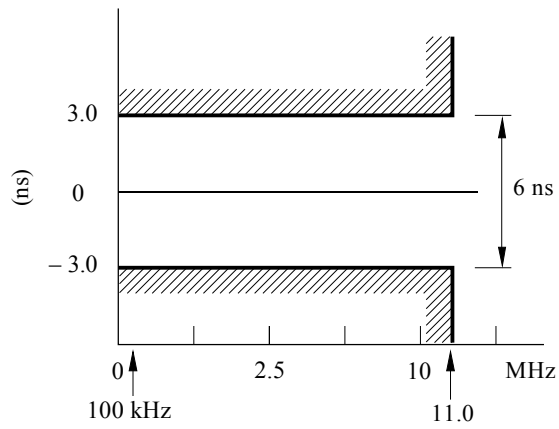

c) Passband group-delay tolerance

Note 1 – Ripple and group-delay are specified relative to values at 100 kHz.