



Recommendation ITU-R F.385-10
(03/2012)

**Radio-frequency channel arrangements for
fixed wireless systems operating in
the 7 110-7 900 MHz band**

F Series
Fixed service

Foreword

The role of the Radiocommunication Sector is to ensure the rational, equitable, efficient and economical use of the radio-frequency spectrum by all radiocommunication services, including satellite services, and carry out studies without limit of frequency range on the basis of which Recommendations are adopted.

The regulatory and policy functions of the Radiocommunication Sector are performed by World and Regional Radiocommunication Conferences and Radiocommunication Assemblies supported by Study Groups.

Policy on Intellectual Property Right (IPR)

ITU-R policy on IPR is described in the Common Patent Policy for ITU-T/ITU-R/ISO/IEC referenced in Annex 1 of Resolution ITU-R 1. Forms to be used for the submission of patent statements and licensing declarations by patent holders are available from <http://www.itu.int/ITU-R/go/patents/en> where the Guidelines for Implementation of the Common Patent Policy for ITU-T/ITU-R/ISO/IEC and the ITU-R patent information database can also be found.

Series of ITU-R Recommendations

(Also available online at <http://www.itu.int/publ/R-REC/en>)

Series	Title
BO	Satellite delivery
BR	Recording for production, archival and play-out; film for television
BS	Broadcasting service (sound)
BT	Broadcasting service (television)
F	Fixed service
M	Mobile, radiodetermination, amateur and related satellite services
P	Radiowave propagation
RA	Radio astronomy
RS	Remote sensing systems
S	Fixed-satellite service
SA	Space applications and meteorology
SF	Frequency sharing and coordination between fixed-satellite and fixed service systems
SM	Spectrum management
SNG	Satellite news gathering
TF	Time signals and frequency standards emissions
V	Vocabulary and related subjects

Note: This ITU-R Recommendation was approved in English under the procedure detailed in Resolution ITU-R 1.

Electronic Publication
Geneva, 2012

© ITU 2012

All rights reserved. No part of this publication may be reproduced, by any means whatsoever, without written permission of ITU.

RECOMMENDATION ITU-R F.385-10

**Radio-frequency channel arrangements for fixed wireless systems
operating in the 7 110-7 900 MHz band**

(Question ITU-R 247/5)

(1959-1963-1978-1982-1986-1990-1992-1994-2001-2005-2007-2012)

Scope

This Recommendation provides RF channel arrangements for fixed wireless systems (FWSs) operating in the 7 GHz band. The main text of as well as Annexes 1 to 5 to this Recommendation present a number of RF arrangements with channel separation of 3.5, 5, 7, 14, and 28 MHz (including the possible use of 2×28 MHz adjacent channels) in the frequency range 7 110-7 900 MHz.

The ITU Radiocommunication Assembly,

considering

- a) that FWSs at data rates up to 155 Mbit/s, including synchronous digital hierarchy bit rates, may operate in the 7 GHz band;
- b) that frequency bands 300 MHz wide may be available for such systems;
- c) that the availability of frequency bands in the range from 7 110 MHz to 7 990 MHz differs in various countries;
- d) that economy may be achieved if several go and return channels are connected to one common transmit-receive antenna;
- e) that many interfering effects can be minimized by a carefully planned arrangement of the radio frequencies in FWSs employing several RF channels;
- f) that digital techniques such as cross-polar interference cancellers (XPIC) may significantly contribute to the cross-polar discrimination improvement factor (XIF, defined in Recommendation ITU-R F.746), thus counteracting multipath propagation-induced depolarization;
- g) that, when very high capacity links (e.g. twice Synchronous Transfer Mode-1 (STM-1)) are required, further economy may be achieved using system bandwidths wider than the recommended channel separation, associated to high efficient modulation formats,

recommends

1 that the preferred RF channel arrangement for several FWSs, operating in the 7 GHz band, should be derived as follows (see Fig. 1 and Note 1):

Let f_0 be the frequency of the centre of the band of frequencies occupied (MHz);

f_n be the centre frequency of one RF channel in the lower half of this band (MHz);

f'_n be the centre frequency of one RF channel in the upper half of this band (MHz),

then the frequencies (MHz) of the individual channels with 7 MHz channel separation are expressed by the following relationships (see Fig. 1a):

$$\text{lower half of the band: } f_n = f_0 - 154 + 7n$$

$$\text{upper half of the band: } f'_n = f_0 + 7 + 7n$$

where:

$$n = 1, 2, 3, \dots, 20;$$

the frequencies (MHz) of the individual channels with 14 MHz channel separation are expressed by the following relationships (see Fig. 1b):

$$\text{lower half of the band: } f_n = f_0 - 157.5 + 14 n$$

$$\text{upper half of the band: } f'_n = f_0 + 3.5 + 14 n$$

where:

$$n = 1, 2, 3, \dots, 10;$$

the frequencies (MHz) of the individual channels with 28 MHz channel separation are expressed by the following relationships (see Fig. 1c):

$$\text{lower half of the band: } f_n = f_0 - 164.5 + 28 n$$

$$\text{upper half of the band: } f'_n = f_0 - 3.5 + 28 n$$

where:

$$n = 1, 2, 3, 4 \text{ and } 5;$$

FIGURE 1
RF channel arrangement for international connection of FWSs
operating in the 7 GHz band
(All frequencies in MHz)

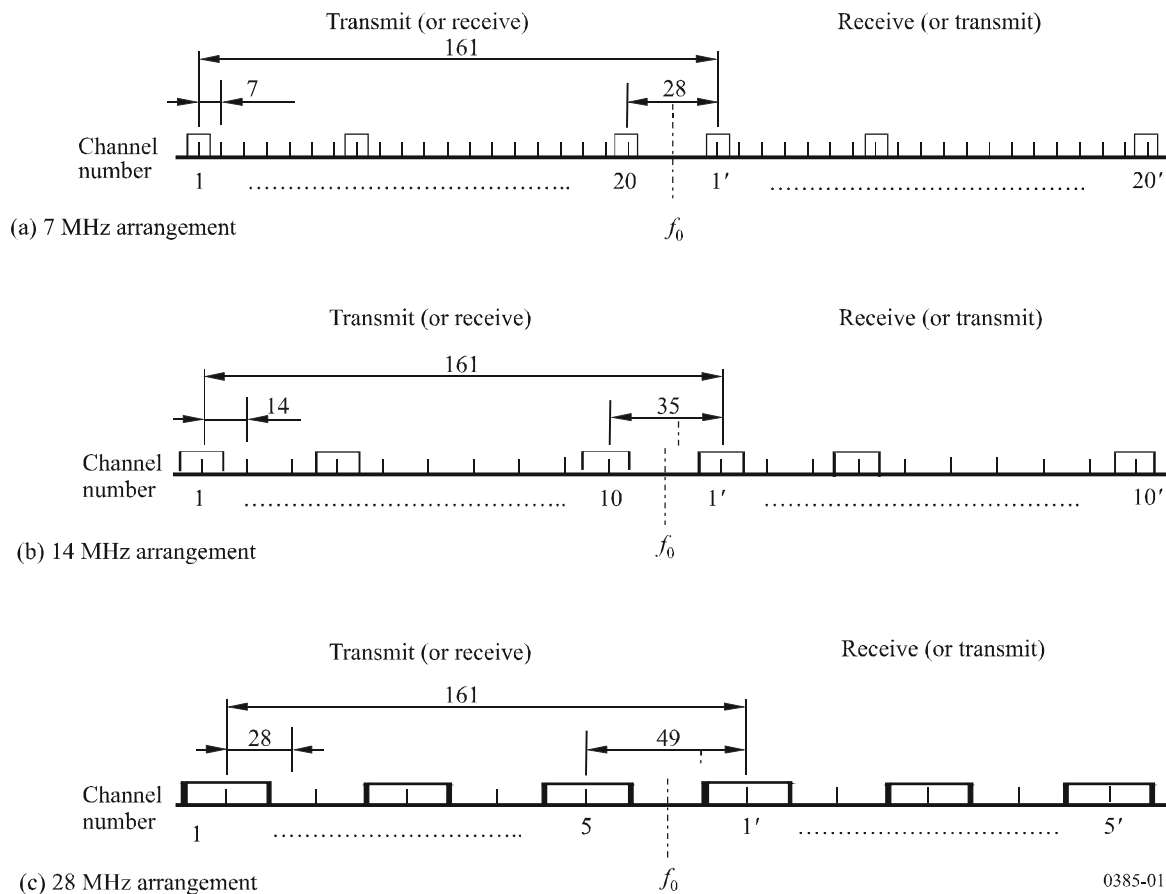

2 that, in a section over which the international connection is arranged, all the go channels should be in one half of the band and all the return channels should be in the other half of the band;

3 that for international connections, the centre frequency should preferably be:

$$f_0 = 7575 \text{ MHz for the band 7425 to 7725 MHz};$$

in addition, other centre frequencies may be used in certain geographical areas by agreement between the administrations concerned, e.g.:

$$f_0 = 7275 \text{ (for the band 7125 to 7425 MHz), } 7400 \text{ (for the band 7250 to 7550 MHz) or } 7700 \text{ MHz (for the band 7550 to 7850 MHz) (see Note 2);}$$

4 that the actual channel arrangement and antenna polarization should be agreed between the administrations concerned;

5 that Annexes 1 to 5 provide RF channel arrangements which may be considered for use by administrations;

6 that, when very high capacity links are required and network coordination permits, with the agreement of the administrations concerned, the use of any two adjacent 28 MHz channels specified in *recommends* 1 is possible, for wider bandwidth system, with centre frequency lying in the central point of the distance between the two 28 MHz adjacent channels;

NOTE 1 – Care should be taken to the outermost channels that might exceed the band limits.

NOTE 2 – The RF channel arrangement with $f_0 = 7700$ MHz overlaps some of the channel arrangements mentioned in Recommendation ITU-R F.386.

Annex 1

RF channel arrangement in the bands 7 125-7 425 MHz and 7 425-7 725 MHz

1 This Annex describes a RF channel arrangement for low, medium and high capacity digital FWSs, operating in the bands 7 125-7 425 MHz and 7 425-7 725 MHz. The RF channel arrangement is shown in Fig. 2 and is derived as follows:

Let f_0 be the frequency of the centre of the band of frequencies occupied (MHz);

f_n be the centre frequency of one RF channel in the lower half of the band (MHz);

f'_n be the centre frequency of one RF channel in the upper half of the band (MHz),

then the frequencies (MHz) of the individual channels, with duplex separation of 154 MHz, are expressed by the following relationships:

a) for channel spacing of 28 MHz (Notes 1 and 2):

$$\text{lower half of the band: } f_n = f_0 - 161 + 28 n$$

$$\text{upper half of the band: } f'_n = f_0 - 7 + 28 n$$

where:

$$n = 1, 2, 3, 4 \text{ and } 5.$$

b) for channel spacing of 14 MHz:

lower half of the band: $f_n = f_0 - 154 + 14 \cdot n$

upper half of the band: $f_n' = f_0 + 14 \cdot n$

where:

$$n = 1, 2, \dots, 10;$$

c) for channel spacing of 7 MHz:

lower half of the band: $f_n = f_0 - 150.5 + 7 \cdot n$

upper half of the band: $f_n' = f_0 + 3.5 + 7 \cdot n$

where:

$$n = 1, 2, \dots, 20;$$

d) for channel spacing of 3.5 MHz:

lower half of the band: $f_n = f_0 - 148.75 + 3.5 \cdot n$

upper half of the band: $f_n' = f_0 + 5.25 + 3.5 \cdot n$

where

$$n = 1, 2, \dots, 40;$$

e) for channel spacing of 1.75 MHz:

lower half of the band: $f_n = f_0 - 147.875 + 1.75 \cdot n$

upper half of the band: $f_n' = f_0 + 6.125 + 1.75 \cdot n$

where:

$$n = 1, 2, \dots, 80.$$

FIGURE 2
Occupied spectrum: 7 125-7 425 MHz and 7 425-7 725 MHz
(all frequencies in MHz)

Guard band	go(return) channels	Centre gap	return(go) channels	Guard band	
3 MHz	1.....5 (28 MHz)	14 MHz	1'.....5' (28 MHz)	3 MHz	
	1.....10 (14 MHz)		1'.....10' (14 MHz)		
	1.....20 (7 MHz)		1'.....20' (7 MHz)		
	1.....40 (3.5 MHz)		1'.....40' (3.5 MHz)		
	1.....80 (1.75 MHz)		1'.....80' (1.75 MHz)		
7 125	7 128	7 268	7 282	7 422	7 425
7 425	7 428	7 568	7 582	7 722	7 725

2 All go channels of the same link should be in one half of the band and all return channels should be in the other half of the band.

3 For adjacent RF channels in the same half of the band, different polarizations may be used for alternate channels or where it is possible, both polarizations may be utilized for each digital radio-frequency channel.

4 The preferred centre frequency f_0 is:
 7 275 MHz for the band 7 125-7 425 MHz;
 7 575 MHz for the band 7 425-7 725 MHz.

NOTE 1 – 56 MHz channels may be provided according to *recommends* 6 of the present Recommendation. Their centre frequencies may be calculated as follows:

$$\text{lower half of the band: } f_n = (f_0 - 147 + 28 \cdot n), \text{ MHz}$$

$$\text{upper half of the band: } f'_n = (f_0 + 7 + 28 \cdot n), \text{ MHz}$$

where: $n = 1, 2, \dots, 4$.

Their numbering is just for identification of the channelling. It should be noted, that adjacent channel numbers cannot be used on the same physical link due to channel overlap.

NOTE 2 – When additional digital radio frequencies interleaved 28 MHz channels between those of the main pattern of Fig. 2 are required, they can be realized using the same f_0 and the equation reported in Note 1.

Annex 2

RF channel arrangement in the band 7 435-7 750 MHz with channel spacings of 5, 10 or 20 MHz

1 This Annex describes a RF channel arrangement suitable for digital FWSs up to 19 Mbit/s (1.544×12) and allows coexistence of digital systems and medium capacity analogue systems spaced on a 20 MHz interval operating in the band 7 435-7 750 MHz. The RF channel arrangement is shown in Fig. 3 and is derived as follows:

Let f_0 be the frequency of the centre of the band of frequencies occupied (MHz);

f_n be the centre frequency of one RF channel in the lower half of the band (MHz);

f'_n be the centre frequency of one RF channel in the upper half of the band (MHz),

then the frequencies (MHz) of the individual channels are expressed by the following relationships:

$$\text{lower half of the band: } f_n = f_0 - 152.5 + 5 n$$

$$\text{upper half of the band: } f'_n = f_0 + 7.5 + 5 n$$

where:

$$n = 1, 2, 3, 4, 5, 6, \dots, 28.$$

FIGURE 3
RF channel arrangement for digital systems operating in the 7 GHz band
(All frequencies in MHz)

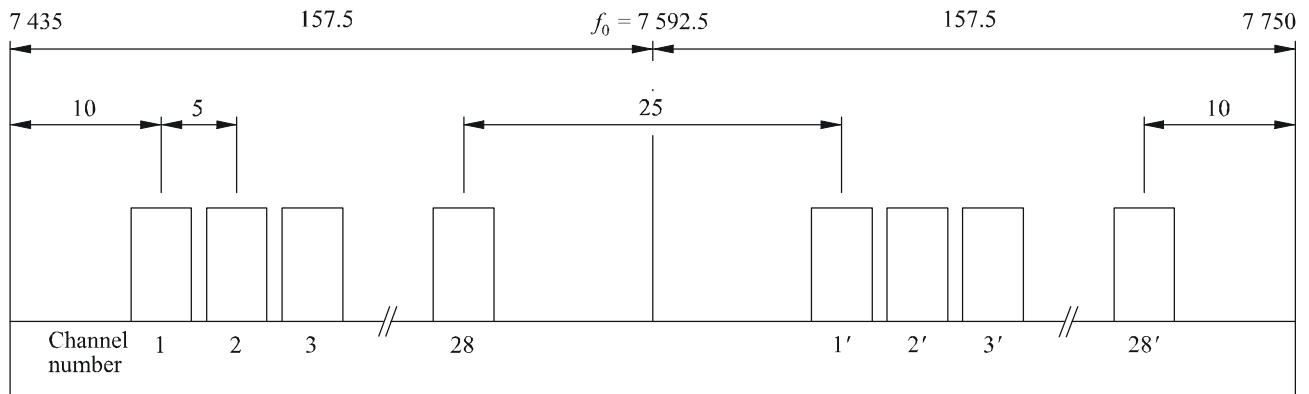

0385-03

2 All go channels should be in one half of the band and all return channels should be in the other half of the band.

3 The centre frequency f_0 is 7592.5 MHz.

4 For all RF channels in the same half of the band, the same polarization may be used or, where it is necessary because of the existence of interference, different polarizations may be utilized.

Where it is possible, both polarizations may be utilized for each digital RF channel.

5 Digital RF channels for 12.6 Mbit/s (1.544×8) or 19 Mbit/s (1.544×12) systems, can be realized by use of a 10 or 20 MHz interval.

Annex 3

RF channel arrangement in the band 7110-7750 MHz with a channel spacing of 28 MHz

This Annex describes a RF channel arrangement for the 7 GHz band.

The arrangement provides for up to ten go and ten return channels, each accommodating about 140 Mbit/s or the synchronous digital hierarchy bit rates subdivided in two groups of five go and five return channels relating to the lower part and the higher part of the band.

The RF channel arrangement is as shown in Fig. 4 and is derived as follows:

Let f_{0l} be the frequency at the centre of the lower part of the band:

$$f_{0l} = 7275 \text{ MHz,}$$

f_{0h} be the frequency at the centre of the higher part of the band:

$$f_{0h} = 7597 \text{ MHz,}$$

f_{nl} be the centre frequency of one RF channel in the lower half of the lower part of the band,

f'_{nl} be the centre frequency of one RF channel in the upper half of the lower part of the band,

f_{nh} be the centre frequency of one RF channel in the lower half of the higher part of the band,

f'_{nh} be the centre frequency of one RF channel in the upper half of the higher part of the band,

then the frequencies (MHz) of the individual channels are expressed by the following relationships:

$$f_{nl} = f_{0l} - 182 + 28 n$$

$$f'_{nl} = f_{0l} + 14 + 28 n$$

$$f_{nh} = f_{0h} - 168 + 28 n$$

$$f'_{nh} = f_{0h} + 28 n$$

where:

$$n = 1, 2, 3, 4, 5.$$

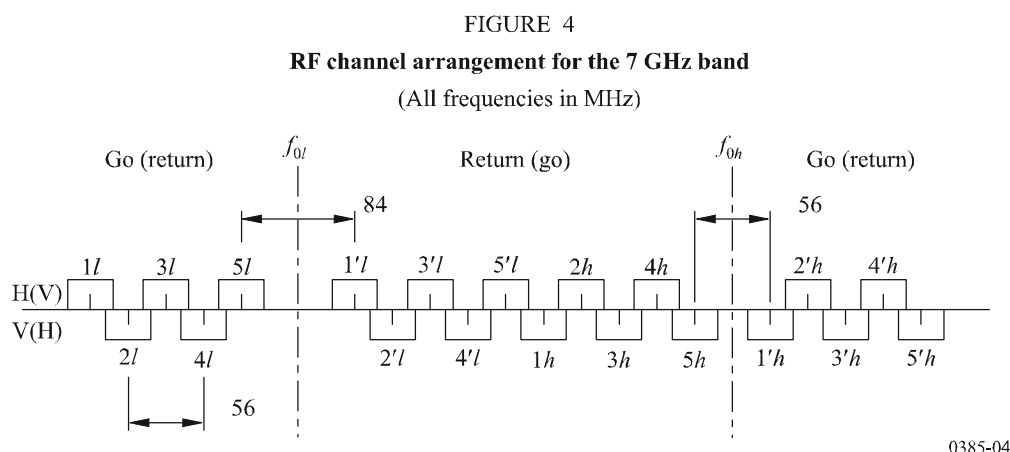

When the equipment and network characteristics permit, the co-channel frequency reuse arrangement can be employed, with the agreement of the administration concerned, for improving spectral efficiency.

Annex 4

RF channel arrangement in the band 7 425-7 900 MHz with a channel spacing up to 28 MHz¹

1 This Annex describes a RF channel arrangement suitable for digital FWSs with a channel spacing up to 28 MHz, and makes provision for eight 28 MHz channels.

¹ The frequency range in this Annex partly overlaps with the band 7 725-8 500 MHz mentioned in Recommendation ITU-R F.386.

The radio-frequency channel arrangement is shown in Fig. 5 and is derived as follows:

Let f_0 be the frequency of the centre of the band of frequencies occupied (MHz);
 f_n be the centre frequency of one RF channel in the lower half of the band (MHz);
 f'_n be the centre frequency of one RF channel in the upper half of the band (MHz),

then the frequencies (MHz) of individual 28 MHz channels are expressed by the following relationships:

$$f_n = f_0 - 248.5 + 28 n$$

$$f'_n = f_0 - 3.5 + 28 n$$

where:

$$n = 1 \text{ to } 8.$$

2 The eight channels with a spacing of 28 MHz can be subdivided to provide 16 channels with a spacing of 14 MHz or 32 channels with a spacing of 7 MHz. The 28 MHz and 14 MHz channels are centred on the 7 MHz pattern of *recommends* 1 and 4, whilst the 7 MHz channels are interleaved with an offset of 3.5 MHz.

FIGURE 5
 RF channel arrangement for digital systems operating in the band 7 425-7 900 MHz
 (All frequencies in MHz)

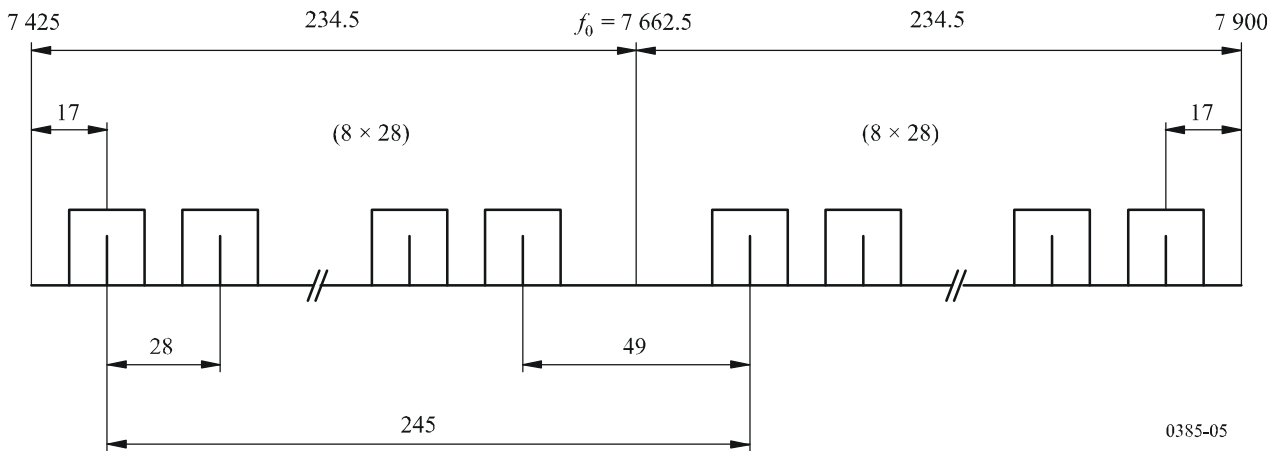

The frequencies (MHz) of individual channels are expressed by the following relationships:

for 14 MHz channels:

$$f_n = f_0 - 241.5 + 14 n$$

$$f'_n = f_0 + 3.5 + 14 n$$

where:

$$n = 1 \text{ to } 16$$

for 7 MHz channels:

$$f_n = f_0 - 238 + 7 n$$

$$f'_n = f_0 + 7 + 7 n$$

where:

$$n = 1 \text{ to } 32.$$

3 All go channels should be in one half of the band and all return channels should be in the other half of the band.

4 The centre frequency f_0 is 7 662.5 MHz.

NOTE 1 – The first five channels with a spacing of 28 MHz in the lower sub-band of the above channel arrangement align with those in Annex 1, covering the 7 425-7 725 MHz band. The go-return spacing is greater as a result of using the full 7 425-7 900 MHz band.

Annex 5

RF channel arrangement for FWSs operating in the 7 250-7 550 MHz band with channel spacings of 28, 14, 7 and 3.5 MHz

This Annex describes a RF channel arrangement suitable for digital FWSs with channel spacings of 28, 14, 7 and 3.5 MHz.

The RF channel arrangement is shown in Fig. 6 and is derived as follows:

Let f_0 be the frequency of the centre of the band of frequencies occupied (MHz);
 f_n be the centre frequency of one RF channel in the lower half of the band (MHz);
 f'_n be the centre frequency of one RF channel in the upper half of the band (MHz);
 $f_0 = 7 400$ MHz;
duplex spacing = 161 MHz.

Then the frequencies (MHz) of individual channels are expressed by the following relationships:

a) for a channel separation of 28 MHz:

$$\begin{aligned} f_n &= f_0 - 161 + 28 n \\ f'_n &= f_0 + 28 n \end{aligned} \quad \text{where } n = 1, 2, \dots, 5$$

b) for a channel separation of 14 MHz:

$$\begin{aligned} f_n &= f_0 - 154 + 14 n \\ f'_n &= f_0 + 7 + 14 n \end{aligned} \quad \text{where } n = 1, 2, \dots, 9$$

c) for a channel separation of 7 MHz:

$$\begin{aligned} f_n &= f_0 - 154 + 7 n \\ f'_n &= f_0 + 7 + 7 n \end{aligned} \quad \text{where } n = 1, 2, \dots, 20$$

d) for a channel separation of 3.5 MHz:

$$\begin{aligned} f_n &= f_0 - 150.5 + 3.5 n \\ f'_n &= f_0 + 10.5 + 3.5 n \end{aligned} \quad \text{where } n = 1, 2, \dots, 39$$

FIGURE 6
RF channel arrangement for FWSs operating in the 7 GHz band
with channel spacings of 28, 14, 7 and 3.5 MHz
 (All frequencies in MHz)

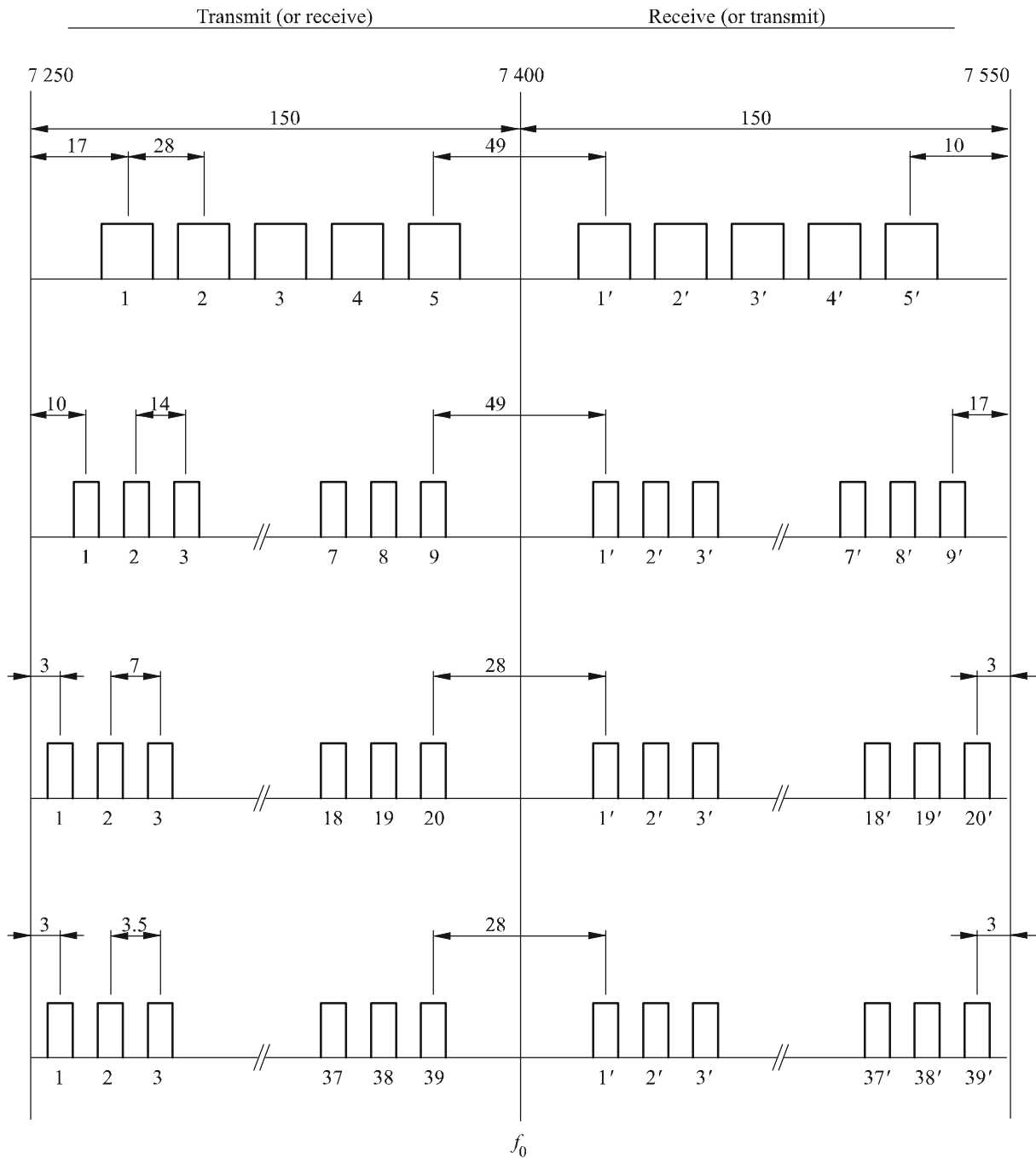

0385-06

NOTE 1 – For the channel spacing of 28 MHz, channel f'_5 may exceed the upper boundary of the 7250-7550 MHz band by 4 MHz, when a channel bandwidth of 28 MHz is used.

NOTE 2 – For the channel spacing of 7 MHz, channel f_1 may exceed the lower boundary and channel f'_{20} may exceed the upper boundary of the 7250-7550 MHz by 0.5 MHz, when a channel bandwidth of 7 MHz is used.