

RECOMMENDATION ITU-R F.757-3*

Basic system requirements and performance objectives for fixed wireless access using mobile-derived technologies offering telephony and data communication services

(Questions ITU-R 215/8 and 140/9)

(1992-1997-1999-2003)

The ITU Radiocommunication Assembly,

considering

- a) that mobile radiocommunication systems offering basic telephony services are already in wide use;
- b) that such systems are implemented both with analogue and digital technologies;
- c) that in some cases it may be desirable, for reasons of convenience and economy, to apply systems derived from mobile technologies for use as FWA (see Annex 2, § 5 for list of acronyms) in both rural and urban areas;
- d) that there is a need for fixed applications using mobile-derived technologies that provide an equivalent access function to metallic lines;
- e) that when used in fixed applications the radio links provided may form part of an international connection;
- f) that the introduction of FWA systems derived from digital mobile technologies will make it possible to offer various types of service including the local grade portion of an ISDN;
- g) that FWA applications using mobile-derived technologies may also operate in bands allocated to the fixed service,

noting

- a) that the terrestrial IMT-2000 radio interfaces supporting both mobile and FWA at user bit rates that include broadband capabilities are covered in Recommendation ITU-R M.1457 and are outside the scope of this Recommendation,

recommends

1 that systems using mobile-derived technologies in fixed applications provide services also available by metallic lines. These services include:

- individual customer telephone service;
- pay-phone service of various kinds;

* This Recommendation was jointly developed by Radiocommunication Study Groups 8 and 9 and any future revision should also be undertaken jointly.

- 4-wire service with and without receive and send “E AND M” signalling;
 - the capability to carry voice-band data signals including facsimile and other telematic services up to a data rate of 9.6 kbit/s;
- 2 that digital systems using mobile-derived technologies in fixed applications should provide the same ISDN access as digital mobile systems;
- 3 that, since such systems used as FWA may form part of an international connection, the relevant G-Series ITU-T Recommendations should be met;
- 4 that, a service quality comparable to that already provided to fixed end-users in urban areas should be offered, e.g. a grade of service better than 1% and should be calculated employing ITU-T Recommendations E.506, E.541 and Supplement No. 1 to the E-series Recommendations. Giving due regard to economical considerations, the grade of service (lost call probability) offered by such a system to an end-user should not normally be worse than 5%;
- 5 that the error performance and availability objectives of digital systems should generally be in accordance with Recommendations ITU-R F.697 and ITU-R F.1400;
- 6 that analogue systems should be designed to provide voice circuits with a noise level less than 1 000 pWp (before companding improvement is taken into account) in the unfaded condition, concerning which further information including availability consideration is provided in Annex 1;
- 7 that Annex 1 should be referred to for the application of mobile-derived technologies as FWA;
- 8 that Annex 2 should be referred to for characteristics of FWA systems based on mobile-derived technologies offering data communications.

Annex 1

Applications of mobile radiocommunication technologies for use as FWA offering basic telephony services

1 Introduction

Mobile radiocommunication systems are already in wide use. The technology for such systems is expanding rapidly.

It is technically feasible, and in some cases it may be desirable for reasons of convenience and economy, to apply mobile-derived radiocommunication systems for use as FWA. FWA systems using mobile technologies are useful in developing countries for reasons of convenience and economy. It is useful also in developed countries, especially where the existing mobile network has coverage and the fixed network needs enhancement (rural areas).

This Annex describes basic system requirements for such applications. Some applications deal with the connection of end-users to the telephone exchange and thereby into the switched network. Other applications include fixed and mobile users in the same network.

For brevity, the application of mobile radiocommunication technologies for use as FWA will be called simply “mobile-derived FWA”.

2 General considerations

The service to be provided forms a permanent, integral part of a communications network.

A number of administrations have already implemented such systems, for the provision of basic telephony services in rural areas. It is important, therefore, to establish the basic system requirements (e.g., performance objectives, frequency bands, implementation process and maintenance aspects) which permit such integration as effectively as possible without degrading overall network performance.

The general goal in rural and remote areas is to establish an overall quality of service equal or better to that achieved by wireline systems in well-served urban areas. A minimum objective towards this goal is to achieve service quality at least comparable to that offered in these urban areas, as proposed in the ITU-T (ex-CCITT) Handbook on Rural Telecommunications (Geneva, 1985) and in Recommendations ITU-R F.756 and UIT-R F.1400.

In some cases, it may be effective to use mobile-derived FWA systems not only in rural areas but also in urban areas, e.g., where the cable infrastructure is temporarily inadequate. The radio system has the advantage that it can be deployed rapidly compared with cable systems. Also it may be another attractive feature that the facilities can be easily converted for mobile use after the cable systems become available.

2.1 Basic approach

There are two basic approaches for mobile-derived FWA. One is to establish an entirely new mobile-derived FWA system, optimised for and dedicated to fixed use, and the other approach is to make minimum changes to the existing or planned mobile systems for adaptation to fixed use.

The former approach may be justified in some cases from the viewpoint of economic considerations. However, it should be taken into account that in many cases it may be desirable that a system can accommodate both mobile and fixed end-users. The latter approach seems preferable for these cases. It is therefore desirable that future mobile systems should include in their design considerations the possible application of the systems for FWA to satisfy its own performance criteria set by the mobile environment, and may well limit the performance achievable by the fixed station. For example, one administration operates mobile systems with a carrier to interference ratio of 18 dB at the edges of the cell. This provides an acceptable level of performance for a mobile system, but could result in unacceptable performance in the fixed service where the radio link is intended to be part of the telephone network and radio is used instead of wire or cable only for convenience and economy. Another factor is that mobile systems are normally optimised for low end-user traffic, 0.02 E, whereas fixed end-user traffic normally averages between 0.05 and 0.09 E.

2.2 Frequency bands

Frequency spectrum is a limited natural resource. Therefore, the frequency bands suitable for mobile communication should be primarily used for the mobile services or fixed applications complementing each other. For this reason, the application of mobile-derived systems for FWA may be justified mainly in rural areas where the demand for mobile communication is small and the provision of telecommunication services by means of wireline facilities is too costly. See also Recommendation ITU-R F.1401 – Frequency bands for fixed wireless access systems and the identification methodology.

If mobile systems are adapted for use as FWA, frequency bands should be the same as those for mobile systems.

Frequency bands commonly used for mobile radio are, for example, in the 400 MHz and 800/900 MHz band, generally below 3 GHz. Any of these bands are, in principle, also suitable for the provision of a fixed service; accordingly, the interference environment in any area where it is proposed to operate must now satisfy criteria for both the fixed service and the mobile service.

2.3 Operational aspects

As a matter of principle, all kinds of telecommunication services offered through wireline facilities could be made available through mobile-derived FWA systems. Most of the services are already provided by mobile systems. Among the services which are not usually provided by mobile systems is the pilot number service (multiple lines) which is essential for key telephones and private branch exchanges.

Some features of mobile systems are not necessary for mobile-derived FWA. Among them are roaming and handover capabilities. In addition, certain sub-systems of mobile systems may require modifications for adaptation to the FWA application. Most important are the numbering plan and charging sub-system. In particular, in cases where a system accommodates both mobile and mobile-derived FWA end-users, the numbering and charging sub-systems should be capable of handling the two categories of end-users, unless the regulation permits a common sub-system to be applicable to both mobile and mobile-derived FWA end-users.

One of the solutions for numbering and charging when mobile systems are introduced into an existing PSTN might be to adopt service control points with common channel signalling.

In providing telecommunications services, consideration must be given to the likely location of the end-user station. While it is possible to locate the end-user terminal at the customer's premises, this is not necessarily the best location for the radio antenna. In hilly terrain, houses are most often built in valleys or where some shielding is provided from the weather. This must be taken into account in the system design by, for example, adapting mobile equipment to feed a 650 Ω loop (including the telephone set) when used in the fixed service.

In some rural areas, the commercial alternating current power is either unavailable or is less reliable than that in urban or suburban areas. Substantial attention must be given to provide reliable power sources for the end-user units in rural areas. To equip a backup battery is one alternative.

2.4 Traffic capacity – grade of service

The grade of service or lost call probability is frequently designed to be of the order of 1%, but it is seldom as high as 5%, while some administrations set requirements in the range 0.1% to 0.5%, in order not to degrade the national network beyond the ITU-T recommended objective of 1%. Care must be taken to allow for appropriate growth in the number of end-users and the higher loss probability figures should, therefore, be avoided, since they will generally result in severe customer dissatisfaction. These probabilities are calculated in the usual manner, employing ITU-T Recommendations E.506, E.541, and Supplement No. 1 to the E-Series Recommendations, as well as Recommendation ITU-R F.756. Factors to consider include:

- the number of radio channels required,
- the number of end-users to be served, and
- the traffic intensity per end-user.

Average traffic intensities of 0.05 to 0.09 E per end-user have been used frequently for rural end-users. The loss probability for up to 6 RF channels is shown in graphical form in the ITU-T (ex-CCITT) Handbook on Rural Telecommunications (Geneva, 1985), page 84, Fig. 7-4(III).

3 Requirements for digital systems

3.1 General

Today's widespread use of digital mobile technologies has provided cost-effective radio equipment for FWA. Such systems have the following features:

- high system availability and good speech quality,
- shorter installation time,
- low initial cost in rural and suburban areas,
- easy maintenance and management of facilities,
- flexible access network construction to respond to changing demand,
- immunity against disasters.

Making use of the above advantages, digital mobile-derived FWA systems have been extensively introduced in many countries. Services provided by mobile-derived FWA systems include 2-wire telephone, public telephone, facsimile and data transmission using modems (up to 9.6 kbit/s). Future provision of ISDN (2B + D) connection is taken into account.

3.2 System configuration

System configuration of a FWA system is shown in Fig. 1. The major components of the system are adapters (ADPs), cell stations (CSs) and end-user stations or subscriber stations (SSs). Cables or radio systems are used for connections between ADPs and CSs. ADPs are positioned between the service node (SN) and the CSs. ADPs function to implement concentration, authentication and so on.

FIGURE 1
FWA system using mobile technologies

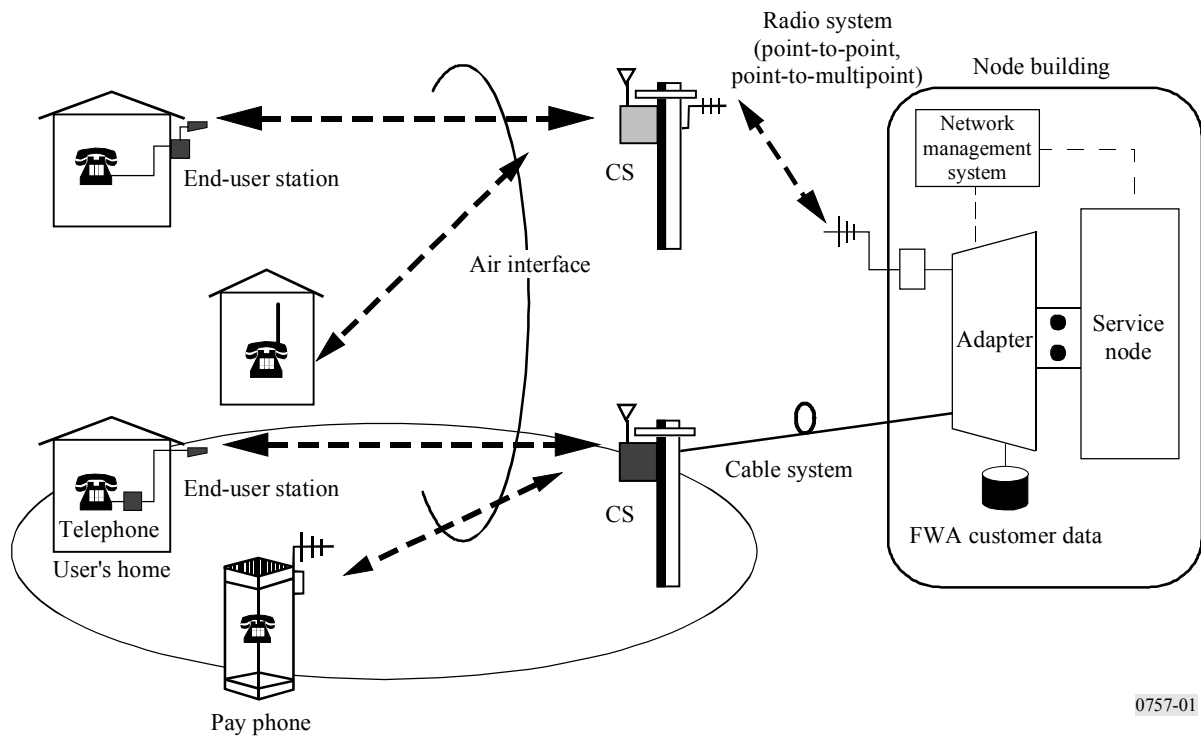

0757-01

Examples of interface between ADPs and CSs may be E1/T1 or those based on ITU-T Recommendations G.964/G.965. CSs are installed outdoors in such locations as at the top of poles. One CS can contain several radio units, each one having a number of message channels depending on the technology used. As a result one CS will provide message channels up to about several tens as well as one control channel. Service area radius of such FWA systems ranges from 0.1 to several tens of kilometres.

Main parameters of reported FWA applications using mobile-derived technologies are given in Table 1. The mobile technologies on which Table 1 is based are defined in Recommendations ITU-R M.1033 and ITU-R M.1073.

3.3 Performance and availability requirements

As specified in *recommends 5* in this Recommendation the error performance and availability objectives of digital FWA systems should generally be in accordance with Recommendations ITU-R F.697 and ITU-R F.1400. Since these Recommendations do not discriminate mobile-derived FWA systems from systems designed purely for fixed use, it is required for mobile-derived FWA systems to meet the objectives in these Recommendations. In particular, to realize the availability objectives in Recommendation ITU-R F.1400, i.e. 99.99% for medium quality applications and 99.999% for high quality applications, the mean time to repair (MTTR) should be sufficiently short in both urban and rural environments.

TABLE 1

Main parameters of reported FWA applications using digital mobile technologies

	D-AMPS-FWA 450/900	IS-95- CDMA-FWA	GSM-FWA 900/1 800	PHS-FWA	DECT-FWA	PDC-FWA 800/1 500
Frequency band (MHz)	440-450/485-495 824-849/869-894	824-849/869-894 1 750-1 780/1 840-1 870 1 850-1 910/1 930-1 990	890-915/935-960 1 710-1 785/1 805-1 880	1 893.5-1 919.6	DECT 1 880-1 900 or 1 900-1 920 FWA 1 910-1 930	810-828/940-958 1 429-1 453/1 477-1 501
Access	TDMA (FDD)	CDMA (FDD)	TDMA (FDD)	TDMA (TDD)	TDMA (TDD)	TDMA (FDD)
Service area radius (km)	Several tens	Up to 62.5	0.1 to 30/0.1 to 20	5	5	Up to 50
Voice coding scheme	IS-54 IS-136	QCELP 13.2 kbit/s EVRC 8 kbit/s	HR 5.6 kbit/s FR, EFR 13 kbit/s	ADPCM	ADPCM	VSELP 6.7 kbit/s PSI-CELP 3.45 kbit/s
Number of channels	(1)	20-30	124/374	348	120	216/288
Network interface ⁽²⁾	T1/E1 ⁽²⁾	T1/E1	E1	G.964/G.965 GR303/PSTN	E1	G.964, G.965 PSTN (analogue 2-wire)

⁽¹⁾ To be provided later.

⁽²⁾ E1 = 2 Mbit/s; T1 = 1.5 Mbit/s.

ADPCM: Adaptative differential pulse code modulation
D-AMPS-FWA: Digital advanced mobile telephone system FWA
DECT-FWA: Digital enhanced cordless telecommunications FWA
EVRC: Enhanced variable rate codec
FDD: Frequency division duplex
FDMA: Frequency division multiple access
GSM-FWA: Global system for mobility FWA
IS-95-CDMA-FWA: Interim Standard-95 code division multiple access FWA

PDC-FWA: Personal digital cellular FWA
PHS-FWA: Personal handyphone system FWA
PSI-CELP: Peripheral subsystem interface-code excited linear prediction
PSTN: Public switched telephone network
QCELP: Quadrature code excited linear prediction
T1/E1: Primary rate transmission system
TDD: Time division duplex
VSELP: Vector sum excited linear prediction

3.4 Implementation process

There are many possible ways to implement access facilities that include mobile-derived FWA systems, as shown in Fig. 2. In the Figure, typical wireless access system consists of ADP, CS, and SS (or end-user station). For example, in a large area accommodated by one SN, there will be a number of small sub-areas at different distances from the SN, having different numbers, densities, and growth-rates of end-users. Therefore, the most important question facing network operators is how to select the optimal (i.e. lowest-cost and highest-efficiency) implementation, given the conditions in each of the sub-areas in question.

FIGURE 2
The access facility forms

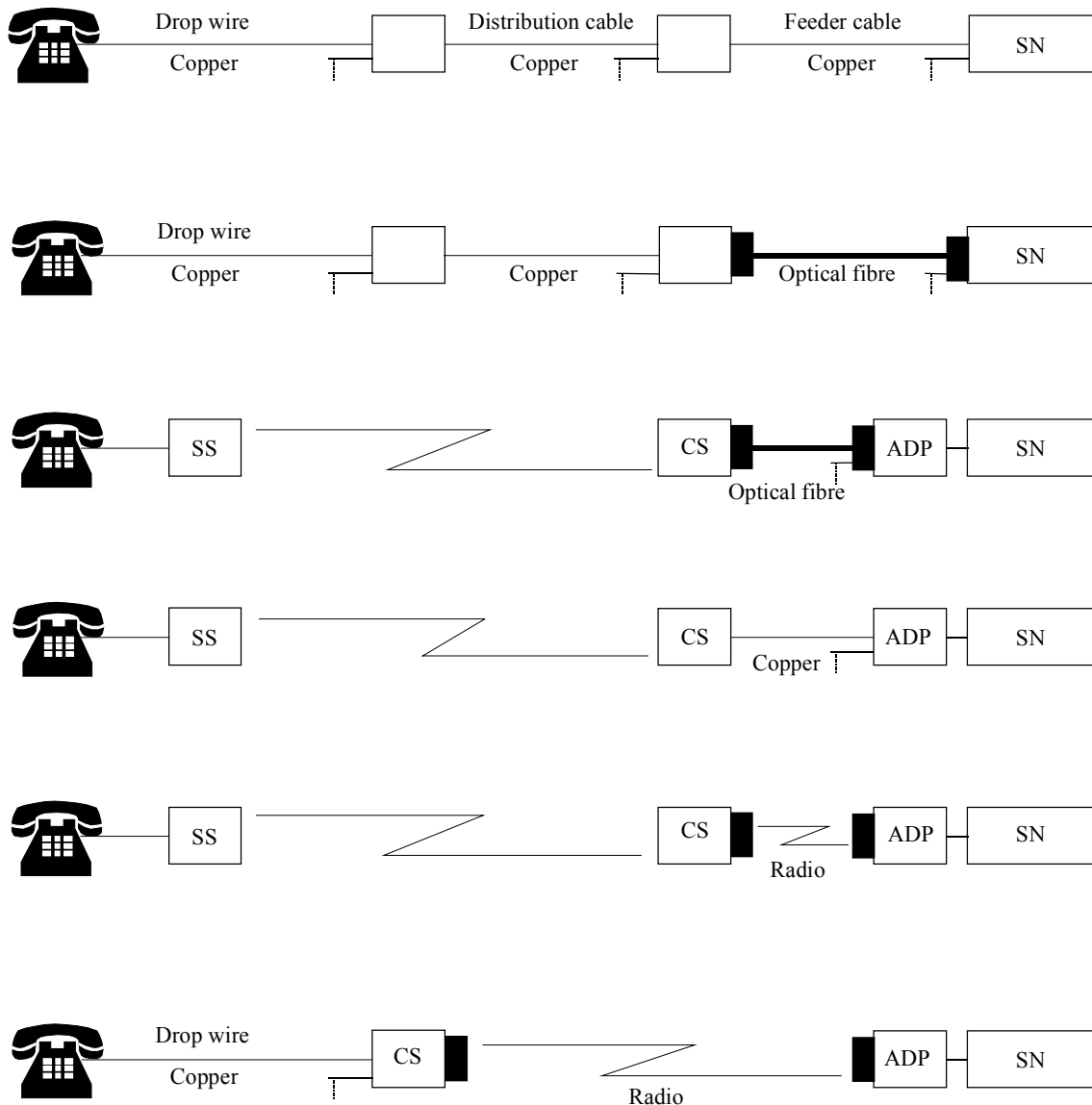

An outline of choosing the most suitable facility is described in Fig. 3.

FIGURE 3
Choosing the appropriate mobile-derived FWA systems

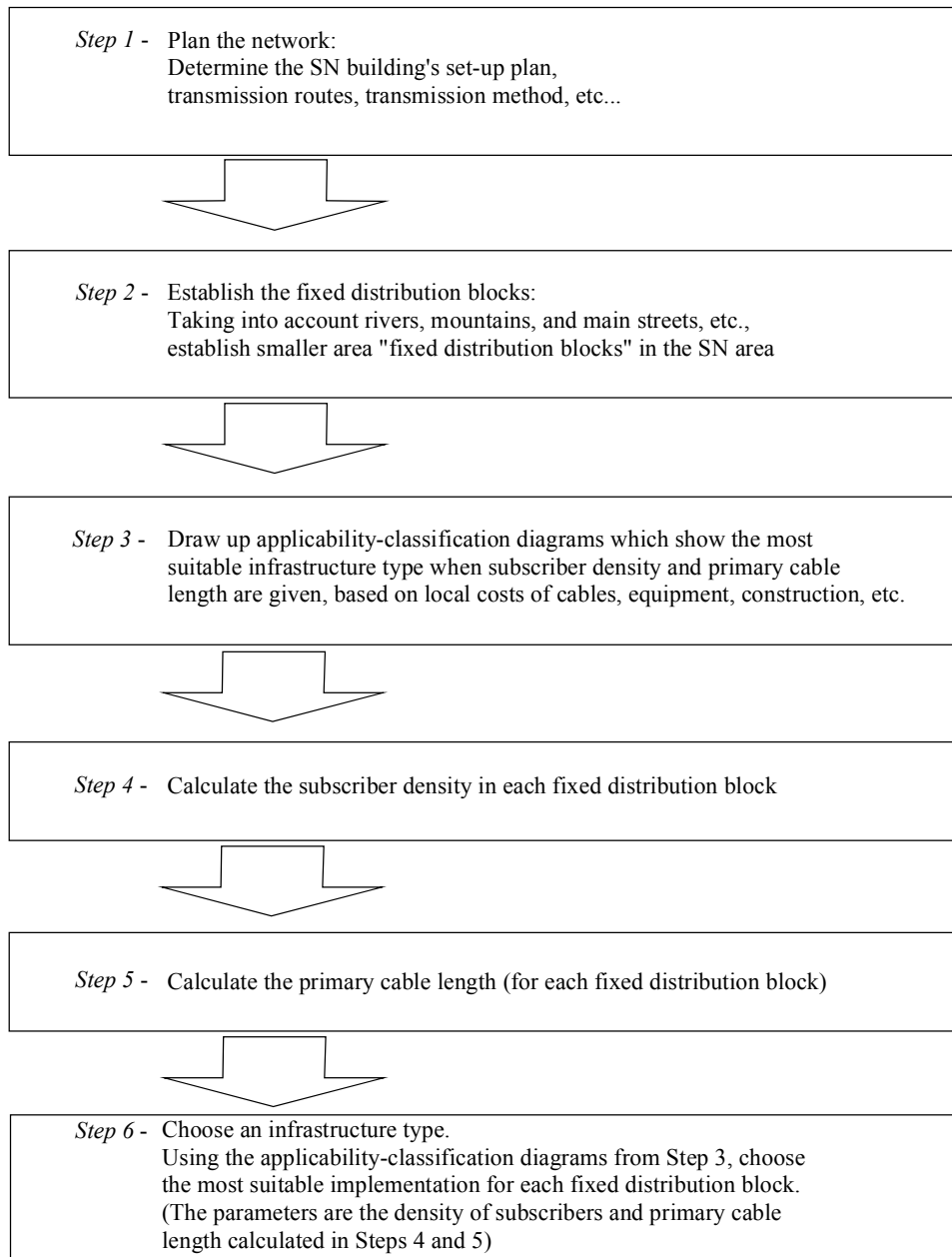

0757-03

3.5 Operation and maintenance aspects

Operators can control and manage several mobile-derived FWA systems from one operations centre. There are two choices of management architectures (tree or ring) for the system. They have different characteristics in terms of cost, reliability etc. and one can switch from one architecture to the other when expanding the system, equipment, or centre.

In terms of functions, there are three systems that constitute the NMS implement functions. The functions of each system is shown below:

- network operation and maintenance system for operations centre;
- facility engineering and management support system for local offices;
- service order system for customer service centre.

Each operations centre holds backup data (for customers, the system, traffic, etc.) fully mirroring one or more other operations centres, to provide protection in case of accidents. If one centre fails, data can be restored from another site or control can be switched to another site for continuous operations.

Relational DBMS provides fast and flexible searching of data, easy collection of statistics, and high-performance transaction processing for large quantities of data. It also supports various forms of data storage, such as floppy disk, magneto-optical disk, etc. Operators can easily manipulate the NMS, determine the current system status, and take appropriate measures using graphical user interface.

4 Summary

Mobile-derived FWA systems are capable of making telecommunication services available to end-users in rural areas and, in particular, to end-users.

Optimized fixed systems can offer, as should be expected, a higher level of performance and service features than might be achieved by the use of mobile radio. The level of performance offered by FWA systems may be acceptable, in some cases, to an administration that requires a basic telephone service for a few widely scattered end-users, especially if the service can be provided very economically within an existing mobile cell. An administration, however, should consider that the performance which can be achieved may degrade national or international connections beyond acceptable national or ITU-T objectives. As is always the case, a full evaluation of suitable radio techniques must be made which will include the consideration of ITU-T and ITU-R Recommendations, comparisons of achievable versus required performance, cost, the lifetime of the equipment, maintenance, reliability, suitability for the local physical environment, services offered, etc.

Annex 2

Characteristics of FWA systems based on mobile-derived technologies offering data communications

1 Introduction

FWA systems based on mobile-derived technologies have advanced significantly in recent years. Those based on digital cordless technologies were originally intended to construct PSTN access networks economically and quickly and such systems provide speech communications mainly using 32 kbit/s ADPCM. Advancements towards third-generation mobile systems have resulted in pre-IMT-2000 enhanced systems capable of offering bit rates of up to 40 kbit/s.

The need for data communications in addition to speech communications are increasing due to the spread of Internet and other multimedia services both in developing countries and developed countries.

This Annex describes data communication using FWA systems based on mobile-derived technologies.

2 General features of FWA systems based on mobile-derived technologies

Table 2 shows examples of FWA systems based on mobile-derived technologies. The mobile technologies on which Table 1 is based are defined in Recommendations ITU-R M.1033 and ITU-R M.1073.

NOTE 1 – The figures in Table 2 are representatives of the base station equipment parameters. Future revisions of this Recommendation will contain the customer premise equipment parameters.

TABLE 2

Examples of FWA systems based on mobile-derived technologies

Item	Specifications			
	PHS	GSM	IS-95	DECT
Frequency band	1.9 GHz band	a) 1.8 GHz band b) 1.9 GHz band	1.9 GHz band	1.9 GHz band
Access method	TDMA/TDD	TDMA/FDMA	CDMA	TDMA/TDD
TDMA frame	5 ms	4.615 ms	Not applicable	10 ms
Traffic channel/ RF carrier	4	8 full-rate	30 (usually adopted value)	Full slot: 12 duplex channels
Information transmission rate/traffic channel	32 kbit/s	Normal burst: 200 kbit/s	14.4 kbit/s 64 kbit/s (IS-95B)	64 kbit/s
Modulation method/ transmission rate	$\pi/4$ shift QPSK/ 384 kbit/s	GMSK/ 271 kbit/s	QPSK (spreading) BPSK (outbound); 64-ary orthogonal (inbound)/ 9.6 or 14.4 kbit/s per channel up to 921.6 kbit/s per IS-95 carrier	GFSK ($BT = 0.5$)/ 1 152 kbit/s
Speech codec	32 kbit/s ADPCM (64 kbit/s PCM)	Full-rate: RPE-LTP 13 kbit/s	QCELP 13.2 kbit/s EVRC 8 kbit/s	32 kbit/s ADPCM (64 kbit/s PCM)
Slots/frame	8	8 full-rate	Not applicable	12

TABLE 2 (end)

Item	Specifications			
	PHS	GSM	IS-95	DECT
Channel bandwidth	288 kHz	200 kHz	1 250 kHz	1.728 MHz
No. of channels	16 (per 4 carrier)	band-dependent: 122 per 25 MHz	61 (per RF carrier)	12
Spectrum efficiency (Erlang/sector/MHz)	7.8 @ 25.8 MHz band; 4 carrier/cell; 15 voice channels/cell; 0.05 E/cell (2% GoS)	2.4 @ 15 MHz Tx band; reuse factor = 4; 6 carrier/sector; 45 voice channels/sector; 35.6 E/sector (2% GoS)	9.5 @ 15 MHz Tx band; reuse factor = 1; 11 carriers/sector; 220 voice channels/sector; 143 E/sector (2% GoS)	
Maximum cell radius (km)	5	35	50	5
Peak transmitter power (dBm)	24	34~55 ⁽¹⁾	23	24
Antenna maximum gain (dBi)	12/3	12~18	16.6	12
Antenna side lobes (dB)	-25/0	-25	-25	-25
Sensitivity (dBm) BER = 1×10^{-3}	-86	-104 ⁽¹⁾	-104	-86
Service node interface	Digital/analogue	Digital/analogue	Digital/analogue	Digital/analogue

⁽¹⁾ ETSI TS 100 910 V.8 11. 0.

3 Data communication methods of FWA

3.1 Voice-band data transmission

There are ITU-T G Series Recommendations as the speech coding method used in the general switched telephone network, and ITU-T V Series Recommendations on data transmission using the general switched telephone network or 4-wire leased telephone-type circuits. The applicable Recommendations depend on the speech coding method. For example, when using ITU-T Recommendation G.726 (32 kbit/s ADPCM), the performance of voiceband data transmission is guaranteed up to 4 800 bit/s (V.27ter). Although it is dependent on the transmission condition, it may be able to communicate at 7 200 bit/s or 9 600 bit/s (see ITU-T Recommendation G.726).

3.2 Digital transmission

In digital transmission methods, the data transmission is the transparent transmission and the typical traffic channels are 14.4 kbit/s, 32 kbit/s and 64 kbit/s. It is possible to transmit at higher rates either using several traffic channels or using wider traffic channels. The transmission rate will be $M \times N$ kbit/s (M : transmission rate per traffic channel; N : number of allocated traffic channels). In an ISDN system, the channel structure is 2B + D and PHS always uses five traffic channels per one subscriber. In DECT wider traffic channels are used.

Examples of mobile-derived FWA are described in the ITU-R FWA Handbook (Second edition of Volume 1 of the ITU-R Land Mobile Handbook).

3.3 Facsimile transmission

There are the following ITU-T T Series Recommendations on facsimile transmission in public switched telephone networks (including ISDN):

- ITU-T Recommendation T.4 for Group 3 facsimile transmission;
- ITU-T Recommendation T.90 for Group 4 facsimile transmission.

These Recommendations are applicable to FWA, although the transmission speed depends on the speech coding and transmission conditions as in the voiceband data transmission for Group 3.

4 Usage pattern of each method and the technical comparisons

4.1 Usage pattern

The usage pattern of each method is shown in Fig. 4.

When using voiceband as in Fig. 4a), 32 kbit/s ADPCM is generally used for the radio section. There are two ways to connect to the PSTN; one is to use 2-wire analogue signals, and the other is to use multiple digital signals. In the latter type, the degradation of the transmission quality due to the analog/digital conversion is smaller.

When transmitting digital data as shown in Fig. 4b), the digital signals are transmitted transparently from end to end. The transmission speed depends on the capability of the FWA system, which might be 32 kbit/s, 64 kbit/s, or ISDN basic rate 2B + D. If error correction is not provided by the FWA system, then it depends on provision by the terminals.

Figure 4c) indicates that PHS Internet access forum standard (PIAFS) is used for FWA section. PIAFS is a data transmission procedure using PHSs 64 kbit/s/32 kbit/s unrestricted digital bearer. PIAFS is transformed when entering PSTN, and conventional modem transmission is realized in PSTN.

FIGURE 4

Usage pattern of data transmission

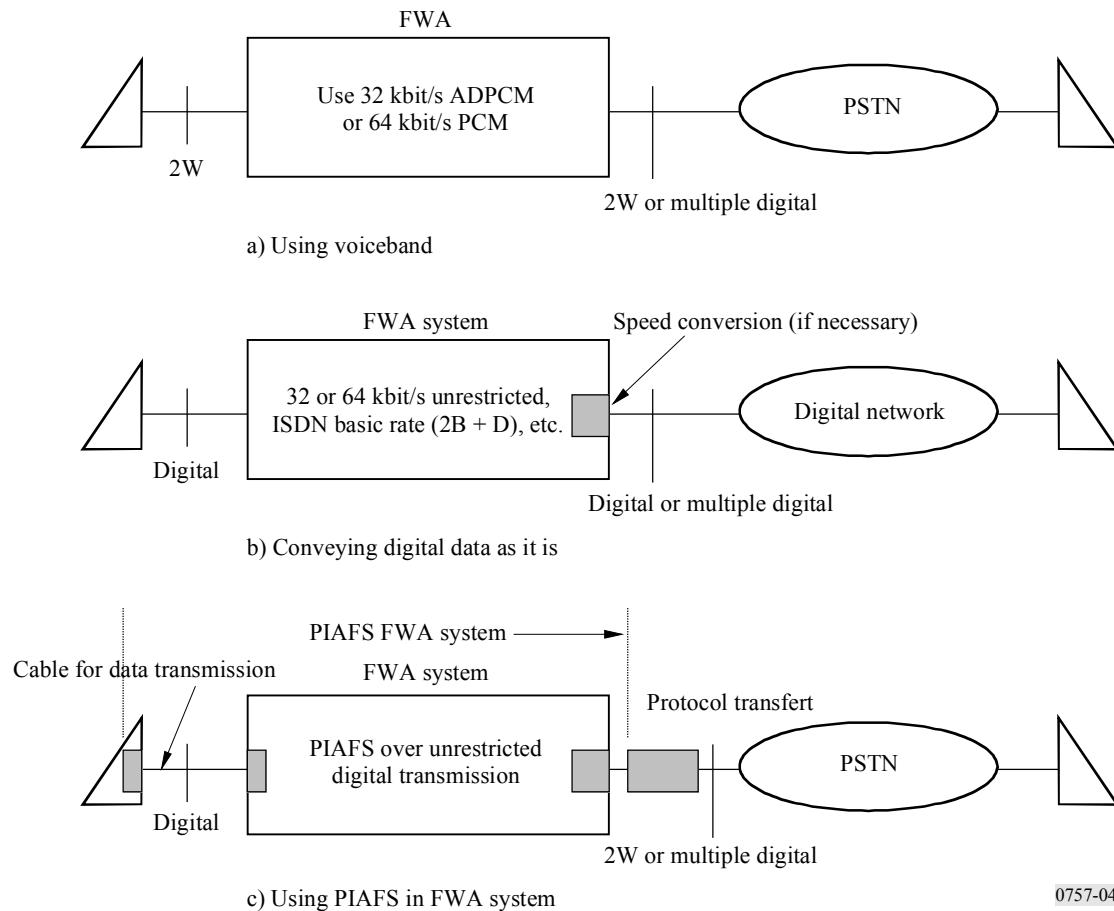

0757-04

4.2 Technical comparisons

Table 3 summarizes the characteristics of each pattern.

When using voiceband, there is basically no need for special adaptation from the FWA system designed for analogue telephone transmission, although the transmission speed is not so high. In order to improve the quality of data transmission, it is desirable that the interface to PSTN is multiple digital interface. Moreover, if the higher transmission speed is necessary, it can be dealt with by using 64 kbit/s PCM coding in FWA system.

When transmitting digital data as it is, a digital interface both to the terminal and to the digital network is necessary, and significant change from the analogue telephone system is necessary. Also, the terminal is limited to a digital terminal.

Use of error-correcting protocols in the FWA system will provide resistance to the effects of radio transmission disturbance. Albeit with a somewhat reduced maximum data rate. When using particular radio protocol in FWA system, new interface is necessary including the data cable for terminals and the protocol transfer equipment has to be attached in the network. However, the transmission is rather stable and not so much influenced by radio transmission disturbance. Also, the conventional terminals can be used. Just for reference, the PIAFS described in Table 3 is the particular transmission system for PHS. This provides transmission control procedures (comparable to OSI reference model layer 2) for high quality data transmission.

Considering the above characteristics of each pattern, the most appropriate data transmission system for the intended application should be chosen.

TABLE 3

Characteristics of each pattern

	Using voiceband	Digital data	Particular radio protocol (using PIAFS)
Data transmission speed (one traffic channel)	4.8 kbit/s, 9.6 kbit/s, etc.	32 kbit/s	29.2 kbit/s
Data transmission speed (multi-traffic channel)	56 kbit/s, etc.	64 kbit/s, 2B + D, etc.	58.4 kbit/s
Influence from the disturbance due to radio environment	Influenced	Influenced	Less influenced
Connectivity to terminal	Conventional modem	Digital terminal only	Conventional modem
Adaptation from FWA system designed for analogue telephone service	Basically no change	Addition of digital interface for terminal and digital network	<ul style="list-style-type: none"> – New interface including the data cable for terminals – Addition of protocol transfer equipment

5 List of acronyms

ADP	Adapter
ADPCM	Adaptive differential pulse code modulation
CELP	Code excited linear prediction
CS	Cell station
DBMS	Data base management system
DECT	Digital enhanced cordless telecommunication
ETSI	European Telecommunications Standards Institute
EVRC	Enhanced variable rate codec
E1 (2 Mbit/s)/ T1 (1.5 Mbit/s)	Primary rate transmission system
FM	Frequency modulation
FWA	Fixed wireless access
GFSK	Gaussian filtered minimum shift keying

GMSK	Gaussian minimum shift keying
GoS	Grade of service
GSM	Global system for mobile communications
ISDN	Integrated services digital network
ITU-R	ITU Radiocommunication Sector
ITU-T	ITU Telecommunication Standardization Sector
MOS	Mean opinion scores
MTTR	Mean time to repair
NMS	Network management system
PCM	Pulse code modulation
PHS	Personal handyphone system
PIAFS	PHS Internet access forum standard
PLMN	Public land mobile network
PSTN	Public switched telephone network
QPSK	Quadriphase pulse shift keying
RPE-LTP	Regular pulse excitation – linear predictive coding
SN	Service node
SS	Subscriber station (end-user station)
TDD	Time division duplex
TDMA	Time division multiple access.

6 References

6.1 ITU-R Recommendation

- Recommendation ITU-R F.395: Noise in the radio portion of circuits to be established over real radio-relay links for FDM telephony
- Recommendation ITU-R F.697: Error performance and availability objectives for the local-grade portion at each end of an integrated services digital network connection at a bit rate below the primary rate utilizing digital radio-relay systems
- Recommendation ITU-R F.754: Radio-relay systems in bands 8 and 9 for the provision of telephone trunk connections in rural areas
- Recommendation ITU-R F.756: TDMA point-to-multipoint systems used as radio concentrators
- Recommendation ITU-R F.1399: Vocabulary of terms for wireless access

- Recommendation ITU-R F.1400: Performance and availability requirements and objectives for fixed wireless access to public switched telephone network
- Recommendation ITU-R F.1402: Frequency sharing criteria between a landmobile wireless access system and a fixed wireless access system using the same equipment type as the mobile wireless access system
- Recommendation ITU-R F.1518: Spectrum requirement methodology for fixed wireless access and mobile wireless access networks using the same type of equipment, when coexisting in the same frequency band
- Recommendation ITU-R M.1033: Technical and operational characteristics of cordless telephones and cordless telecommunication systems
- Recommendation ITU-R M.1073: Digital cellular land mobile telecommunication systems.

6.2 ITU-T Recommendations

- ITU-T Recommendation E.506: Forecasting international traffic
- ITU-T Recommendation E.541: Overall grade of service for international connections (subscriber-to-subscriber)
- ITU-T Recommendation G.103: Hypothetical reference connections
- ITU-T Recommendation G.123: Circuit noise in national networks
- ITU-T Recommendation G.162: Characteristics of compandors for telephony
- ITU-T Recommendation G.165: Echo cancellers
- ITU-T Recommendation G.173: Transmission planning aspects of speech service in digital public land mobile networks
- ITU-T Recommendation G.711: Pulse code modulation (PCM) of voice frequencies
- ITU-T Recommendation G.726: 40, 32, 24, 16 kbit/s adaptive differential pulse code modulation (ADPCM)
- ITU-T Recommendation G.728: Coding of speech at 16 kbit/s using low-delay code excited linear prediction
- ITU-T Recommendation G.729: Coding of speech at 8 kbit/s using conjugate-structure algebraic-code-excited linear-prediction (CS-ACELP)
- ITU-T Recommendation G.964: V-Interfaces at the digital local exchange (LE) –V5.1 Interface (based on 2 048 kbit/s) for the support of access network (AN)

- ITU-T Recommendation G.965: V-Interfaces at the digital local exchange (LE) – V5.2 interface (based on 2 048 kbit/s) for the support of access network (AN)
- ITU-T Recommendation P.75: Standard conditioning method for handsets with carbon microphones
- ITU-T Recommendation P.76: Determination of loudness ratings; fundamental principles
- ITU-T Recommendation P.78: Subjective testing method for determination of loudness ratings in accordance with Recommendation P.76
- ITU-T Recommendation P.79: Calculation of loudness ratings for telephone sets
- ITU-T Recommendation T.4: Standardization of Group 3 facsimile terminals for document transmission
- ITU-T Recommendation T.90: Characteristics and protocols for terminals for telematic services in ISDN
- ITU-T Recommendation V.17: A 2-wire modem for facsimile applications with rates up to 14 400 bit/s
- ITU-T Recommendation V.21: 300 bits per second duplex modem standardized for use in the general switched telephone network
- ITU-T Recommendation V.22: 1 200 bits per second duplex modem standardized for use in the general switched telephone network and on point-to-point 2-wire leased telephone-type circuits
- ITU-T Recommendation V.22bis: 2 400 bits per second duplex modem using the frequency division technique standardized for use on the general switched telephone network and on point-to-point 2-wire leased telephone-type circuits
- ITU-T Recommendation V.23: 600/1 200-baud modem standardized for use in the general switched telephone network
- ITU-T Recommendation V.26bis: 2 400/1 200 bits per second modem standardized for use in the general switched telephone network
- ITU-T Recommendation V.26ter: 2 400 bits per second duplex modem using the echo cancellation technique standardized for use on the general switched telephone network and on point-to-point 2-wire leased telephone-type circuits
- ITU-T Recommendation V.27bis: 4 800/2 400 bits per second modem with automatic equalizer standardized for use on leased telephone-type circuits
- ITU-T Recommendation V.27ter: 4 800/2 400 bits per second modem standardized for use in the general switched telephone network
- ITU-T Recommendation V.29: 9 600 bits per second modem standardized for use on point-to-point 4-wire leased telephone-type circuits

- ITU-T Recommendation V.32: A family of 2-wire, duplex modems operating at data signalling rates of up to 9 600 bit/s for use on the general switched telephone network and on leased telephone-type circuits
- ITU-T Recommendation V.32*bis*: A duplex modem operating at data signalling rates of up to 14 400 bit/s for use on the general switched telephone network and on leased point-to-point 2-wire telephone-type circuits
- ITU-T Recommendation V.34: A modem operating at data signalling rates of up to 33 600 bit/s for use on the general switched telephone network and on leased point-to-point 2-wire telephone-type circuits
- ITU-T Recommendation V.90: A digital modem and analogue modem pair for use on the Public Switched Telephone Network (PSTN) at data signalling rates of up to 56 000 bit/s downstream and up to 33 600 bit/s upstream.

6.3 Other ITU publications

ITU-R Handbook on Land Mobile (including Wireless Access), Volume 1, Fixed Wireless Access – Second Edition, 2001.

ITU-T (ex-CCITT) Handbook on Rural Telecommunications (1985).
