



**Recommendation ITU-R M.1478-2**  
(01/2012)

**Protection criteria for Cospas-Sarsat search  
and rescue instruments in the band  
406-406.1 MHz**

**M Series**  
**Mobile, radiodetermination, amateur  
and related satellite services**

## Foreword

The role of the Radiocommunication Sector is to ensure the rational, equitable, efficient and economical use of the radio-frequency spectrum by all radiocommunication services, including satellite services, and carry out studies without limit of frequency range on the basis of which Recommendations are adopted.

The regulatory and policy functions of the Radiocommunication Sector are performed by World and Regional Radiocommunication Conferences and Radiocommunication Assemblies supported by Study Groups.

## Policy on Intellectual Property Right (IPR)

ITU-R policy on IPR is described in the Common Patent Policy for ITU-T/ITU-R/ISO/IEC referenced in Annex 1 of Resolution ITU-R 1. Forms to be used for the submission of patent statements and licensing declarations by patent holders are available from <http://www.itu.int/ITU-R/go/patents/en> where the Guidelines for Implementation of the Common Patent Policy for ITU-T/ITU-R/ISO/IEC and the ITU-R patent information database can also be found.

### Series of ITU-R Recommendations

(Also available online at <http://www.itu.int/publ/R-REC/en>)

Series	Title
<b>BO</b>	Satellite delivery
<b>BR</b>	Recording for production, archival and play-out; film for television
<b>BS</b>	Broadcasting service (sound)
<b>BT</b>	Broadcasting service (television)
<b>F</b>	Fixed service
<b>M</b>	<b>Mobile, radiodetermination, amateur and related satellite services</b>
<b>P</b>	Radiowave propagation
<b>RA</b>	Radio astronomy
<b>RS</b>	Remote sensing systems
<b>S</b>	Fixed-satellite service
<b>SA</b>	Space applications and meteorology
<b>SF</b>	Frequency sharing and coordination between fixed-satellite and fixed service systems
<b>SM</b>	Spectrum management
<b>SNG</b>	Satellite news gathering
<b>TF</b>	Time signals and frequency standards emissions
<b>V</b>	Vocabulary and related subjects

*Note: This ITU-R Recommendation was approved in English under the procedure detailed in Resolution ITU-R 1.*

Electronic Publication  
Geneva, 2012

© ITU 2012

All rights reserved. No part of this publication may be reproduced, by any means whatsoever, without written permission of ITU.

## RECOMMENDATION ITU-R M.1478-2

**Protection criteria for Cospas-Sarsat search and rescue instruments in the band 406-406.1 MHz**

(2000-2004-2011)

**Scope**

This Recommendation provides protection criteria for Cospas-Sarsat search and rescue instruments placed on-board satellites in geostationary, medium-Earth and low-Earth orbits (LEO) and receiving signals from emergency position indicating radio beacons (EPIRBs) and other distress beacons operating in the 406-406.1 MHz band.

The ITU Radiocommunication Assembly,

*considering*

- a) that the Cospas-Sarsat global satellite-based search and rescue system operates within an exclusive allocation in the band 406-406.1 MHz;
- b) the analysis provided in Annex 1 concerning maximum allowable spectral power flux-density (spfd) requirements of the Sarsat Search and Rescue Processor (SARP) against broadband out-of-band emissions and the upper bound on Doppler frequency shift associated with MSS transmissions received by Sarsat;
- c) the analysis provided in Annex 2 concerning maximum allowable power flux-density (pfd) requirements for the Sarsat SARP against narrow-band spurious emissions;
- d) that Annex 3 provides guidelines for using the protection requirements of the 406-406.1 MHz band for the Sarsat SARP instruments (on-board satellite equipment);
- e) that Annex 4 provides guidelines for protection of the primary safety services allocated in the band 406-406.1 MHz (C-S system) from non-GSO MSS downlink emissions below 406 MHz;
- f) that Annexes 5, 6 and 7 provide guidelines for the protection of 406-406.1 MHz search and rescue repeaters (SARR) on Sarsat LEO satellites, geostationary operational and environmental satellites (GOES) and meteosat second generation (MSG) satellites respectively;
- g) that Annexes 8 and 9 provide guidelines for the protection of 406-406.1 MHz search and rescue repeaters (SARR) on geostationary satellites (Electro) and navigational satellites (GLONASS) respectively,

*recommends*

- 1** that analysis to determine the effect upon Sarsat SARP instruments by systems using adjacent frequency bands should be based upon a maximum acceptable spfd at the Sarsat antenna of  $-198.6 \text{ dB(W/(m}^2 \cdot \text{Hz))}$ ;
- 2** that analysis to determine the effect upon the Sarsat SARP instruments from narrow-band spurious emissions (e.g. harmonic emissions, parasitic emissions, intermodulation products and frequency conversion products) should be based upon a maximum pfd of  $-166.2 \text{ dB(W/m}^2)$  at the Sarsat antenna within a resolution bandwidth of 19 Hz;
- 3** that analysis to determine the effect upon Cospas SARP instruments by systems using adjacent frequency bands should be based upon a maximum acceptable spfd at the Cospas antenna of  $-198.6 \text{ dB(W/(m}^2 \cdot \text{Hz))}$ ;

4 that analysis to determine the effect upon the Cospas SARP instruments from narrow-band spurious emissions (e.g. harmonic emissions, parasitic emissions, intermodulation products and frequency conversion products) should be based upon a maximum pfd of  $-170.6 \text{ dB(W/m}^2\text{)}$  at the Cospas antenna within a resolution bandwidth of 40 Hz;

5 that analysis to determine the effect upon Cospas-Sarsat non-GSO instruments by proposed MSS systems using the 405-406 MHz frequency band should utilize an upper bound Doppler shift of 20 kHz;

6 that analysis to determine the effect upon Sarsat LEO repeaters by systems using adjacent frequency bands should be based on a maximum spfd at the Sarsat antenna of  $-181.3 \text{ dB (W/(m}^2 \cdot \text{Hz))}$ ;

7 that analysis to determine the effect upon GOES GEO repeaters by systems using adjacent frequency bands should be based on a maximum spfd at the Sarsat antenna of  $-201.1 \text{ dB (W/(m}^2 \cdot \text{Hz))}$ ;

8 that analysis to determine the effect upon MSG GEO repeaters by systems using adjacent frequency bands should be based on a maximum spfd at the Sarsat antenna of  $-206.4 \text{ dB (W/(m}^2 \cdot \text{Hz))}$ ;

9 that analysis to determine the effect upon Electro GEO repeaters by systems using adjacent frequency bands should be based on a maximum spfd at the Cospas antenna of  $-198.7 \text{ dB (W/(m}^2 \cdot \text{Hz))}$ ;

10 that analysis to determine the effect upon GLONASS MEO repeaters by systems using adjacent frequency bands should be based on a maximum spfd at the Cospas antenna of  $-205.2 \text{ dB (W/(m}^2 \cdot \text{Hz))}$ .

## Annex 1

### Protection criteria for Cospas-Sarsat in the band 406-406.1 MHz against out-of-band broadband emissions

#### 1 Introduction

This Annex provides information relating to the C-S system and its protection requirements from broadband out-of-band emissions.

#### 2 Background

Other ITU texts provide substantial information concerning the following items:

- parameters of several non-GSO MSS networks;
- pfd threshold level of interference;
- search and rescue (SAR) protection using spectral shaping or filtering techniques.



**3 spfd threshold level of interference**

The addition of broadband noise to the Sarsat SARP will have the effect of increasing the system bit error ratio (BER), and therefore adversely affect its performance. As identified in ITU-R studies the maximum acceptable uplink BER for the Sarsat SARP cannot exceed  $5 \times 10^{-5}$ . Based upon this requirement, this analysis identifies the maximum acceptable pfd associated with broadband noise in the Sarsat SARP uplink channel. The analysis does not address the effect of narrow-band emissions (e.g. spectral lines), which will also adversely affect the SARP’s performance nor does it address the protection requirements for all C-S instruments (e.g. Sarsat search and rescue repeater, Cospas SARP).

Figure 1 shows the main hardware elements on board the NOAA satellites (and on the future METOP satellites).

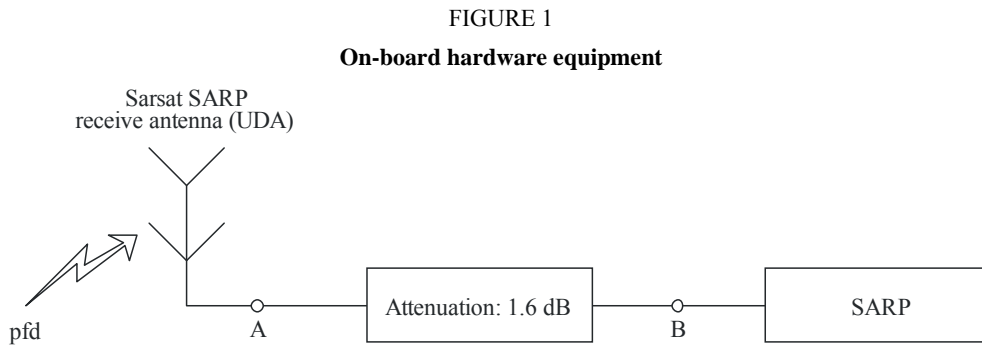

M.1478-01

The UDA antenna gain pattern specification is expressed according to the nadir angle in Table 1:

TABLE 1  
**SARP receive antenna (UDA) gain pattern**

Nadir satellite angle	62	59	54	47	39	31	22	13	5	0
Gain in RHCP	3.85	3.54	2.62	1.24	-0.17	-1.33	-2.24	-3.08	-3.80	-3.96
Gain in LHCP	-5.69	-6.23	-7.52	-9.39	-11.39	-13.12	-14.52	-15.77	-17.17	-18.00
Axial ratio	6.02	5.85	5.59	5.26	4.90	4.57	4.31	4.11	3.78	3.49

The specified figures in Table 1 are of the 406 MHz-Sarsat receive antenna pattern for the SARP, as they should be for the NOAA and METOP satellites.

The Sarsat typical figures are: noise figure = 2.5 dB (C-S SARP input parameter), nominal background noise temperature = 1 000 K (C-S input parameter), attenuation between the antenna and the SARP receiver = 1.6 dB. Thus, the system noise temperature at the input of the SARP receiver (point B on Fig. 1) equals 1010 K and therefore, the noise spectral density equals  $N_0 = -198.6$  dB(W/Hz).

The worst-case specification states that the SARP is designed to operate correctly when the received signal has a power  $C = -161$  dBW (minimum level of the received signal) at the input of the receiver, which provides an effective  $E_b/N_0 = 9.1$  dB in the bit detector of the SARP if we take into account the beacon waveform and the various losses. In this case, the corresponding BER equals  $2.6 \times 10^{-5}$ .

Therefore, in order to achieve a BER of  $5 \times 10^{-5}$  (which is an approximate doubling of the BER) the maximum acceptable degradation is 0.3 dB. At  $E_b/N_0 = 8.8$  dB, the BER equals  $4.8 \times 10^{-5}$ .

Hereunder, the additive noise corresponding to the 0.3 dB degradation for the  $C/N_0$  is calculated.

Let  $I_0$  represent the additive noise power density coming from the non-GSO MSS interferers.

The initial  $N_0$  noise becomes  $N_0 + I_0$ .

The signal-to-noise ratio  $C/N_0$  becomes  $C/(N_0 + I_0)$ .

The degradation is  $0.3 \text{ dB} = 10 \log ((C/N_0)/(C/(N_0 + I_0)))$ , thus  $I_0/N_0 = -11.5 \text{ dB}$  and  $I_0 = -210.1 \text{ dB(W/Hz)}$  which corresponds to a temperature of 70.8 K, and therefore an increase of 7% of the system noise temperature at the input of the SARP receiver.

Therefore, the maximum admissible level of noise density is  $I_0 = -210.1 \text{ dB(W/Hz)}$  (calculated for point B in Fig. 1).

As shown in Fig. 1, the noise density,  $I_0$ , takes into account the attenuation and the antenna gain. As the spfd is required, it is necessary to transform this figure in  $\text{dB(W/(m}^2 \cdot \text{Hz))}$ . The equivalent surface area of an antenna having a gain  $G$  is  $S = G \frac{\lambda^2}{4\pi}$ . Therefore, the corresponding spfd equals  $-210 + 1.6$  (losses)  $- 10 \log_{10} S = -198.6 \text{ dB(W/(m}^2 \cdot \text{Hz))}$ , taking into account the highest satellite nadir angle.

The maximum level of broadband noise interference in the band 406-406.1 MHz shall not exceed  $-198.6 \text{ dB(W/(m}^2 \cdot \text{Hz))}$  to protect the Sarsat SARP instrument.

#### 4 Upper bound on Doppler shift

Any proposed protection bandwidth should also account for the Doppler shifts. The value of the maximum Doppler shift must be carefully examined. The worst case occurs when the Sarsat and the non-GSO MSS satellites are located on the same orbit and travel in opposite directions. In this case, the analysis below applies.

The non-GSO MSS signal comes from point A. The Sarsat satellite is represented by point B. The Sarsat satellite is moving at a speed  $V_B$ . If the non-GSO MSS satellite is not moving, the received frequency at B is  $F_B = F_A (1 + \frac{V_B}{c})$  in the worst case. On the other hand, the received frequency at B has the same value if the Sarsat satellite is not moving and if the non-GSO MSS satellite is moving. If the altitude of the satellite equals 850 km, its speed is 7426 km/s.

As the two satellites are moving in opposite directions, the upper bound Doppler shift equals:

$$2F_A (V_B/c) = 20 \text{ kHz}$$

This is a worst-case situation and is not necessarily applicable to all the proposed MSS systems.

#### 5 Conclusions and recommendations

Following the above computations, the conclusions and recommendations regarding the impact of emissions from adjacent frequency bands on the Sarsat SARP are:

- the maximum level of broadband noise interference in the band 406-406.1 MHz shall not exceed  $-198.6 \text{ dB(W/(m}^2 \cdot \text{Hz))}$  to protect the Sarsat SARP instrument;
- the upper bound on Doppler shift is 20 kHz;

- it is recommended that further analyses be conducted to determine the impact on C-S from MSS occupying the 405-406 MHz band using an spfd of  $-198.6 \text{ dB(W/(m}^2 \cdot \text{Hz))}$ , an appropriate Doppler shift and accounting for the worst-case scenario associated with the entire MSS constellation as envisaged.

## Annex 2

### Protection criteria for C-S system in the band 406-406.1 MHz against narrow-band spurious emissions

#### 1 Introduction

This Annex provides information relating to the C-S system and its protection requirements against narrow-band spurious emissions.

#### 2 Background

Annex 1 contains the protection criteria for Sarsat SARP in the band 406-406.1 MHz to be used as a basis for analysis of interference from out-of-band emissions. This Annex provides protection requirements for the Sarsat SARP instrument in respect of interference from narrow-band spurious emissions (harmonic emissions, parasitic emissions, intermodulation products and frequency conversion products).

The terminology used in this Annex is derived from Recommendation ITU-R SM.328 – Spectra and bandwidth of emissions, and from Recommendation ITU-R SM.329 – Unwanted emissions in the spurious domain.

This Annex addresses protection criteria for only Sarsat SARP instruments and does not necessarily represent the protection criteria for all Cospas-Sarsat instruments.

#### 3 Protection requirement from narrow-band spurious emissions

Figure 1 shows the main Sarsat SARP hardware elements.

To better understand the rationale of this specification, it is necessary to briefly recall the functioning of the SARP instrument.

Sarsat distress beacon transmissions begin with 160 ms of unmodulated carrier to allow a phase-locked loop to lock more easily on the carrier. Figure 2 represents the C-S message format.

FIGURE 2  
C-S message format

160 ms carrier	Synchronization bits	Distress beacon message content bits
----------------	----------------------	---

A spectrum analyser in the SARP instrument continuously monitors the full coverage bandwidth in search of the pure carrier portion of distress beacon transmissions. When the spectrum analyser detects such a line, it considers that it is the beginning of a C-S message. The theory is based on the detection of a pure carrier wave (sine wave) in a white, additive and Gaussian noise environment. The power spectral density of the received signal (pure carrier + noise) is computed using fast Fourier transform techniques, and each signal above the system threshold is processed as if it were a distress beacon (see Fig. 3).

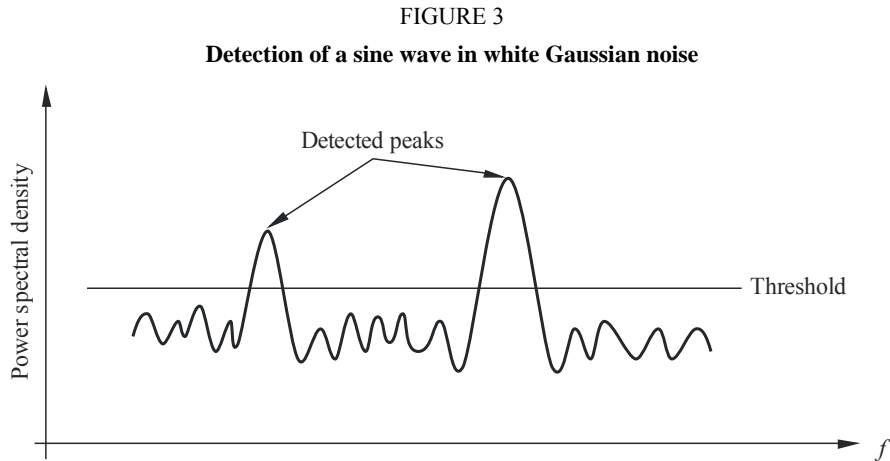

M.1478-03

Signals above the threshold level are assigned to an on-board data recovery unit (DRU) for further processing and transmission to the Earth on the mission telemetry channel (see Fig. 4).

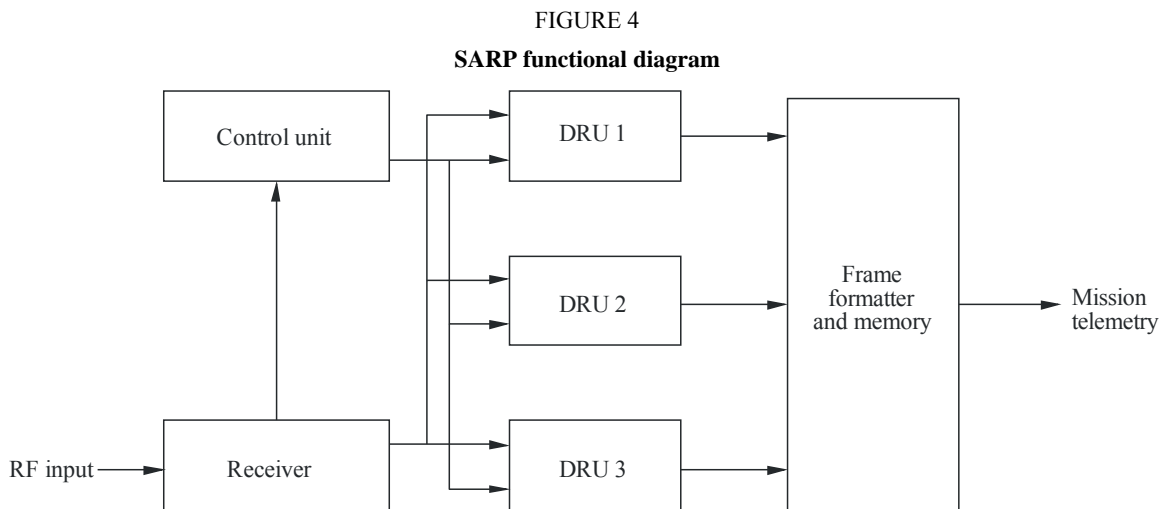

M.1478-04

In order to satisfy SAR performance requirements in respect of low power distress beacons, the Sarsat SARP instrument has been designed to detect and process extremely weak signals. Its performance is such that any signal,  $C_{min}$ , which exceeds the local noise density level by 21 dB(Hz) ( $C_{min}/N_0 > 21$  dB(Hz)) would be assigned to a DRU for additional processing. Consequently, narrow-band interfering signals meeting this criteria would cause a DRU to be assigned to it. The consequence would be that the performance of the SARP, in terms of capacity (e.g. the number of simultaneous distress messages that are able to be processed), would be seriously degraded.



The Sarsat typical figures are: noise factor = 2.5 dB (C-S SARP typical figure), nominal background noise temperature = 1 000 K (C-S input parameter), attenuation between the antenna and the SARP receiver = 1.6 dB. Thus, the system noise temperature at the input of the SARP receiver (point B on Fig. 1) equals 1010 K and therefore, the noise spectral density equals  $N_0 = -198.6$  dB(W/Hz).

As  $C_{min}/N_0 = 21$  dB(Hz),  $C_{min} = -177.6$  dBW. Therefore any narrow-band spurious emission greater than  $-177.6$  dBW at the input of the SARP (point B of Fig. 1), would result in a degradation to system capacity.

It is then necessary to compute this maximum admissible level of spectral line at the input of the Sarsat antenna.

The Sarsat SARP receive antenna gain pattern specification is expressed according to the nadir angle in Table 2.

TABLE 2  
SARP receive antenna (UDA) gain pattern

Nadir satellite angle	62	59	54	47	39	31	22	13	5	0
Gain in RHCP	3.85	3.54	2.62	1.24	-0.17	-1.33	-2.24	-3.08	-3.80	-3.96
Gain in LHCP	-5.69	-6.23	-7.52	-9.39	-11.39	-13.12	-14.52	-15.77	-17.17	-18.00
Axial ratio	6.02	5.85	5.59	5.26	4.90	4.57	4.31	4.11	3.78	3.49

Therefore, the maximum admissible power at point A of Fig. 1 equals  $-177.6 + 1.6$  (losses) =  $-176$  dBW, taking into account the highest satellite nadir angle. As the pfd is required, it is necessary to transform this figure in dB(W/m<sup>2</sup>). The equivalent surface area of an antenna having a gain  $G$  is  $S = G \frac{\lambda^2}{4\pi} = 0.105$  m<sup>2</sup> corresponding to the highest satellite nadir angle. Therefore, the corresponding pfd equals  $-176 - 10 \log_{10} S = -166.2$  dB(W/m<sup>2</sup>).

The required protection level is: no narrow-band spurious emission above  $-166.2$  dB(W/m<sup>2</sup>) at the input of any Sarsat SARP satellite antenna.

#### 4 Conclusion

Following the above computations, the conclusions and recommendations regarding the impact of spurious narrow-band emissions, on the Sarsat SARP shall not exceed  $-166.2$  dB(W/m<sup>2</sup>) at the input of any Sarsat SARP antenna.

## Annex 3

### Guidelines for using the protection requirements of the 406-406.1 MHz band (C-S system)

#### 1 Definitions of characteristics of emissions

##### 1.1 Out-of-band emission

Emission on a frequency or frequencies immediately outside the necessary bandwidth which results from the modulation process, but excluding spurious emissions.

##### 1.2 Spurious emission

Emission on a frequency, or frequencies, which are outside the necessary bandwidth and the level of which may be reduced without affecting the corresponding transmission of information. Spurious emissions include harmonic emissions, parasitic emissions, intermodulation products and frequency conversion products, but exclude out-of-band emissions.

##### 1.3 Unwanted emissions

Consist of spurious emissions and out-of-band emissions.

##### 1.4 Necessary bandwidth

For a given class of emission, the width of the frequency band which is just sufficient to ensure the transmission of information at the rate and with the quality required under specified conditions.

#### 2 Procedure for computing the level of unwanted emissions relating to the Sarsat SARP

##### 2.1 Out-of-band emissions

The unit of an unwanted out-of-band emission is  $\text{dB}(\text{W}/(\text{m}^2 \cdot \text{Hz}))$  (spfd). The overall spfd is in fact an aggregate spfd which is defined as the summation of all spfd coming from the whole potential sources of unwanted out-of-band emissions.

##### 2.2 Spurious emissions

The C-S receiver processors are designed to detect discrete spectral components (unmodulated beacon carrier). The protection requirement is expressed in terms of pfd, and the unit of a spurious emission is  $\text{dB}(\text{W}/\text{m}^2)$  (pfd).

The resolution bandwidth of the receiver of the Sarsat SARP instrument is 19 Hz. It means that the minimum frequency spacing between spectral lines (also called resolving power of the spectrum analysis) that the Sarsat SARP receiver may detect, equals 19 Hz. Consequently, a spurious emission level should be computed within a reference bandwidth of 19 Hz.

##### 2.3 Unwanted emission limits

Figure 5 recaps the values of unwanted emission limits.

FIGURE 5  
Levels of unwanted emissions

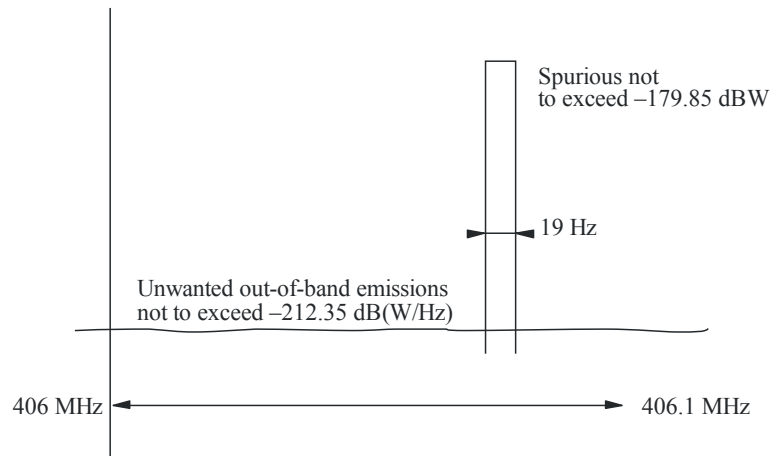

M.1478.05

The unwanted out-of-band emissions must not exceed  $-198.6 \text{ dB(W/(m}^2 \cdot \text{Hz))}$  at the input of any Sarsat SARP antenna: this figure can also be transformed into a spectral power density (dB(W/Hz)):

$$-210.1 \text{ dB(W/Hz)} \text{ (at the input of the SARP instrument)} + 1.6 \text{ (losses)} - 3.85 \text{ (antenna gain)} = -212.35 \text{ dB(W/Hz)} \text{ at the input of any Sarsat SARP antenna.}$$

The narrow-band spurious emission must not exceed  $-166.2 \text{ dB(W/m}^2)$  at the input of any Sarsat satellite antenna: this figure can also be transformed into a power level (dBW):

$$-177.6 \text{ dBW} \text{ (at the input of the SARP instrument)} + 1.6 \text{ (losses)} - 3.85 \text{ (antenna gain)} = -179.85 \text{ dBW} \text{ at the input of any Sarsat SARP antenna.}$$

All the above values are valid at the input of any Sarsat SARP antenna.

## Annex 4

### Protection of the primary safety services allocated in the band 406-406.1 MHz (C-S system) from non-GSO MSS downlink emissions below 406 MHz

#### 1 Introduction

The international C-S system has been operational since 1985 and has already contributed to saving thousands of lives worldwide. It is, therefore, essential to protect its proper operation.

## 2 Background

Other ITU texts provide substantial information regarding the following items:

- parameters of several non-GSO MSS networks;
- pfd threshold level of interference; and
- SAR protection using spectral shaping or filtering techniques.

Annex 1 provides protection criteria for Sarsat SARP in the band 406-406.1 MHz. This Annex provides additional information relating to Cospas SARP receiver protection requirements.

## 3 Protection criteria for Cospas SARP in the band 406-406.1 MHz against out-of-band broadband emissions

The performance of the SARP is expressed by its BER and is directly related to the signal-to-noise density ratio,  $C/N_0$  (dB(Hz)).

The Cospas receiver noise temperature is 300 K. The nominal background noise temperature varies from 300 K in Antarctica to 1000 K in highly populated areas. As a distress beacon signal can be originated from any point on the globe and its decoding should not be impaired by interference from MSS satellite, the most interference sensitive case occurs at the lowest background noise temperature i.e. 300 K.

The attenuation between the antenna and the Cospas SARP receiver is 1.6 dB. The cable noise temperature is 300 K. Thus, the system noise temperature at the input of the SARP receiver equals 600 K and, therefore, the noise spectral density,  $N_0$  is  $-200.82$  dB(W/Hz).

The specified Cospas SARP BER is less than  $1 \times 10^{-5}$ . In accordance with a theoretical BPSK modulation performance, this corresponds to  $E_b/N_0 = 9.6$  dB in the bit detector of the SARP.

As identified in ITU-R studies the maximum acceptable BER of the Cospas-Sarsat uplink should not exceed  $5 \times 10^{-5}$  which is achieved when  $E_b/N_0 = 8.8$  dB.

Therefore, the maximum acceptable degradation to the  $E_b/N_0$  is 0.8 dB, which corresponds to increase of noise density  $N_0 = 200.02$  dB(W/Hz).

If  $I$  is the additive noise power density contribution from non-GSO MSS interferers, then the value of noise density becomes  $N_0 + I$ , and the bit energy to noise density ratio becomes  $E_b/(N_0 + I)$ .

The acceptable degradation is  $0.8 \text{ dB} = 10 \log ((E_b/N_0)/(E_b/(N_0 + I)))$ . Thus  $I/N_0 = -6.94$  dB and  $I = -207.8$  dB(W/Hz) which corresponds to a noise temperature increase of 120.23 K (an increase of 20% of the system noise temperature at the input of the Cospas SARP receiver).

The maximum admissible level of noise density,  $I$ , is  $-207.8$  dB(W/Hz) at the input satellite receiver.

The noise density,  $I$ , takes into account the attenuation and the antenna gain. To express the figure in spfd, it is necessary to transform this value to dB(W/(m<sup>2</sup> · Hz)). The equivalent surface area of an

antenna having a gain  $G$  is  $S = G \frac{\lambda^2}{4\pi}$ . As the maximum gain of the spiral cone antenna installed on the Cospas spacecraft is 6 dB, then  $S = 0.174$  m<sup>2</sup>. Therefore, the corresponding spfd equals  $-207.8 + 1.6$  (losses)  $- 10 \log_{10} S = -198.6$  dB(W/(m<sup>2</sup> · Hz)).

The maximum level of broadband noise interference in the band 406-406.1 MHz shall not exceed  $-198.6$  dB(W/(m<sup>2</sup> · Hz)) in order to provide adequate protection for the Cospas SARP instrument.

#### 4 Protection criteria for Cospas SARP in the band 406-406.1 MHz against narrow-band spurious emissions

The Cospas SARP continuously scans the 406-406.1 MHz band (one scan duration is 60 ms) in search of beacon signals which exceed the SARP detection threshold. After a signal is detected the SARP DRU will be locked for at least 520 ms on the signal frequency. A single interfering signal from an MSS satellite in the 406-406.1 MHz band could capture both on board DRUs making a Cospas satellite unavailable for processing real beacon distress signals.

In order to satisfy SAR performance requirements in respect of low power distress beacons, the Cospas SARP instrument has been designed to detect and process extremely weak signals. Its performance is such that any emission ( $C_{min}$ ) at a power level which exceeds the power noise density level by 21 dB ( $C_{min}/N_0 > 21$  dB(Hz)) would be assigned to a DRU for additional processing. Consequently, any interfering signals in the processed bandwidth 406-406.1 MHz meeting this criteria would cause a DRU to be assigned to it. Therefore, a beacon message would be lost even if the narrow-band interfering signal did not affect the beacon signal directly.

The noise spectral density,  $N_0$ , was calculated to be  $-200.82$  dB(W/Hz).

As  $C_{min}/N_0 = 21$  dB(Hz),  $C_{min} = -179.82$  dBW. Therefore, any narrow-band spurious emission greater than  $-179.82$  dBW at the input of the SARP would degrade the Cospas SARP beacon processing capacity.

The Cospas SARP receive antenna maximum gain is 6 dB. Therefore, the maximum admissible power at the antenna input is equal to  $-179.82 + 1.6$  (losses) =  $-178.22$  dBW. As the pfd is required, it is necessary to transform this figure to dB(W/m<sup>2</sup>). The equivalent surface area of an

antenna having the gain  $G = 6$  dB is  $S = G \frac{\lambda^2}{4\pi} = 0.174$  m<sup>2</sup>. Therefore, the corresponding flux-density equals  $-178.2 - 10 \log_{10} S = -170.6$  dB(W/m<sup>2</sup>).

The maximum level of narrow-band spurious emissions should not exceed  $-170.6$  dB(W/m<sup>2</sup>) at the input of Cospas SARP satellite antenna in order to provide adequate protection for the Cospas SARP instrument.

The C-S receiver processors are designed to detect discrete spectral components (unmodulated beacon carrier). Therefore, the protection requirement is expressed in terms of power spectrum rather than power spectrum density, and the unit of spurious emission is dB(W/m<sup>2</sup>) (pfd). The resolution bandwidth of the receiver of the Cospas SARP instrument is 40 Hz. Therefore, the minimum frequency spacing between spectral lines (also called resolving power of the spectrum analysis) that the Cospas SARP receiver can detect is 40 Hz. Consequently, a spurious emission level should be computed within a reference bandwidth of 40 Hz.

#### 5 Desensitization and front-end burn out of the Cospas receiver

The Cospas satellites use high sensitivity receivers with wideband low noise amplifiers (LNAs) and could experience overload or, in the worst case, front-end burn out from non-GSO MSS emissions.

Blocking or desensitization are generally observed when the lack of RF filtering cause the saturation of the front stage LNA and thus a decrease in its gain and in the receiver sensitivity. Other effects such as the mixing of the interfering signal with the phase noise of the LNA can combine with the above. As a general observation, the experience shows that when a narrow-band transmitter operates close to a wideband receiver, the blocking or desensitization is often the dominant cause of interference problems.



Cospas 406 MHz receiver LNAs can withstand signals of  $-60$  dBW (front-end burn out) and  $-100$  dBW (desensitization). As the non-GSO MSS satellite power can be as high as 24 dBW it is clear that burn-out of Cospas satellite receivers could occur if not prevented by frequency separation.

The power level of non-GSO MSS signals at Cospas receiver input depends on many factors, the most important of which is the distance between the non-GSO MSS and Cospas satellites, which theoretically can be as small as zero for some of the anticipated non-GSO MSS satellite constellations. In view of the catastrophic consequences of the front-end burn out of Cospas receivers, the non-GSO MSS carrier frequencies should be selected to ensure that none of their declared bandwidth extends above 406 MHz. Table 3 presents the key factors for calculating the minimum guardband to protect Cospas receivers against burn out from non-GSO MSS satellite emissions.

TABLE 3

Doppler shift defined	20 kHz $2 \times 406\ 000 \times (7.4/300\ 000)$
Stability of Tx of space station for this band	8.12 kHz $20 \times 10^{-6} \times 406\ 000$
Stability of SARP receiver per year (in assumption of lifetime of satellite 12 years) (Sarsat-3 launched in 1986)	2.45 kHz
Non-GSO MSS declared bandwidth/2	1.2-500 kHz $(2.4-1\ 000)/2$
Guardband	31.8-530.6 kHz

The results presented in Table 3 indicate that, as a minimum, a 32 kHz guardband (405.968-406 MHz) would be required if the 405-406 MHz frequency band was allocated for use by non-GSO MSS.

## Annex 5

### Protection criteria in the 406-406.1 MHz band for Sarsat SARR instruments

#### 1 Minimum acceptable performance for the 406 MHz SARR channel in NOAA satellites

To reliably detect 406 MHz distress beacons using the Sarsat LEO 406 MHz satellite repeaters, the BER of the channel must not exceed  $5 \times 10^{-5}$ .

#### 2 Analysis of spfd that causes interference

The BER of a communications channel is derived from the ratio of the energy contained in each data bit,  $E_b$ , to the noise density, the noise density being comprised of the noise developed by Cospas-Sarsat equipment,  $N_0$ , and the noise caused by interference from other systems,  $I_0$ . Figure 6 depicts the LEO SARR 406 MHz channel with interference on the uplink.

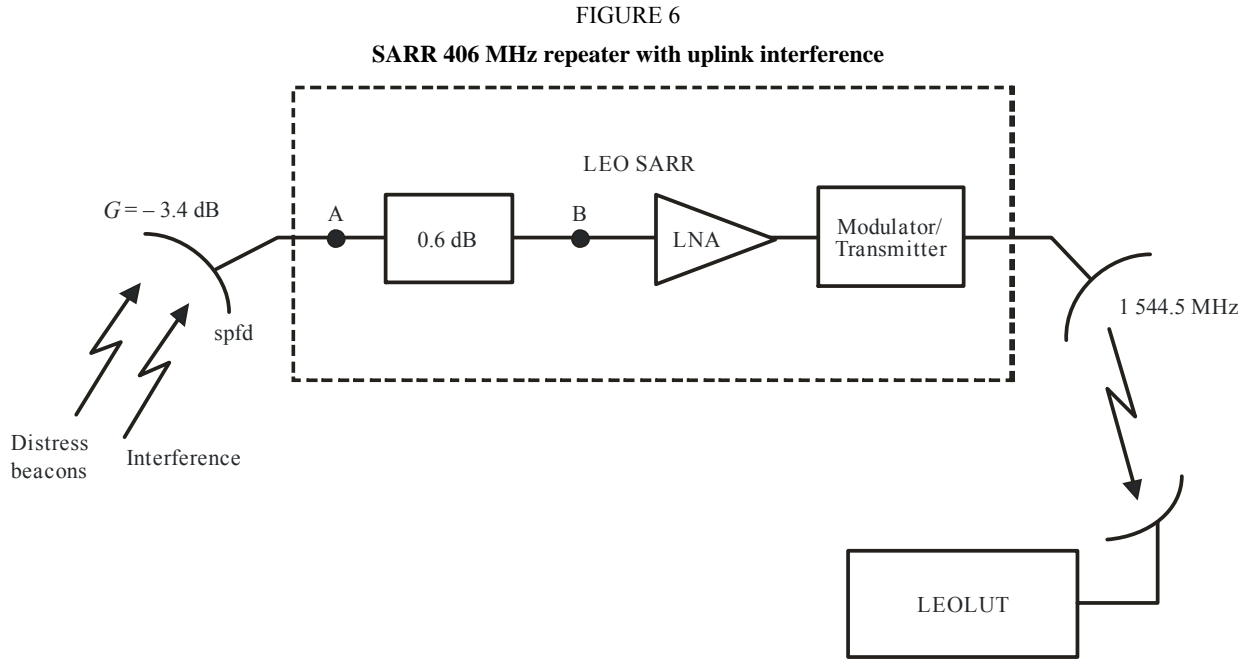

M.1478-06

To achieve a BER of  $5 \times 10^{-5}$ , the ratio of the energy per bit to noise plus interference density  $E_b/(N_0 + I_0)$  at the LEOLUT demodulator must equal or exceed 8.8 dB. This analysis determines the maximum amount of broadband noise-like interference specified as an spfd referenced to the input to the Sarsat LEO 406 MHz satellite antenna that could be accommodated without degrading the overall link  $E_b/(N_0 + I_0)$  below 8.8 dB.

As depicted in Fig. 6, 406 MHz distress beacon signals received by the LEO search and rescue repeater and phase modulated onto a 1 544.5 MHz downlink carrier for detection and processing by LEOLUTs. The antenna gain and system noise temperature for the satellite repeater is  $-4$  dB and 1 000 K at point B (Fig. 6).

This analysis assumes three simultaneously active beacons transmitting at the exact same time on three different frequencies in the 406-406.1 MHz band. The desired beacon has an elevation angle of  $5^\circ$  with respect to the spacecraft. The two other beacons are included in the analysis because they share the available satellite repeater power.

When no external sources of interference are present, the overall  $C/N_0$  is 38.8 dB(Hz), which equates to an  $E_b/N_0$  of 12.8 dB. Accounting for implementation and beacon data demodulation losses, the effective ratio of  $E_b/N_0$  is 10.8 dB. Since the channel requires an overall  $E_b/(N_0 + I_0)$  of at least 8.8 dB to reliably meet performance requirements, the accumulation of broadband interference on the uplink that reduces the overall carrier to noise plus interference density ratio by more than 2 dB cannot be accommodated.

Since the  $C/N_0$  overall in the absence of interference equates to 38.8 dB(Hz), broadband noise-like interference on the uplink that degrades the overall link by 2 dB, results in a  $(C/N_0)_{overall}$  of:

$$\begin{aligned} (C/N_0)_{overall \text{ with interference}} &= (C/N_0)_{OI} = (C/N_0)_{overall} - 2 \text{ dB} \\ (C/N_0)_{OI} &= 38.8 \text{ dB(Hz)} - 2 \text{ dB} \\ (C/N_0)_{OI} &= 36.8 \text{ dB(Hz)} \end{aligned} \tag{1}$$

The  $(C/N_0)_{OI}$  can be calculated from the carrier to noise plus interference density ratios of the uplink and downlink as indicated below:

$$(C/N_0)_{OI} = ((C/N_0)_{up \text{ with interference}}^{-1} + (C/N_0)_{down \text{ with interference}}^{-1})^{-1} \quad (\text{numeric}) \quad (2)$$

Since this analysis concerns interference on the uplink,  $(C/N_0)_{up \text{ with interference}}$  in equation (2) becomes:

$$(C/N_0)_{up \text{ with interference}} = (C_{\uparrow}/(N_0 + I_0)) \quad (\text{numeric}) \quad (3)$$

The interferer also affects the downlink carrier-to-noise density ratio,  $(C/N_0)_{\downarrow}$ , by increasing the total power shared within the SAR bandwidth. This increased total power decreases the power sharing loss and affects the  $(C/N_0)_{\downarrow}$  as follows:

$$(C/N_0)_{down \text{ with interference}} = (C/N_0)_{\downarrow} \times (Lpsi/Lps) \quad (\text{numeric}) \quad (4)$$

where  $Lps$  is the power sharing loss without interference and  $Lpsi$  is the power sharing loss with interference.  $Lpsi$  is calculated as follows:

$$Lpsi = C_{\uparrow}/C_{\uparrow} + 2 \times C_2 + N_{\uparrow} + I_0 B \quad (\text{numeric}) \quad (5)$$

where  $C_2$  is the power level from one of the two other beacon simultaneously received by the LEOSAR repeater.

Substituting equation (5) into equation (4) and then substituting equations (3) and (4) into equation (2) and solving for  $I_0$  results in the following formula:

$$I_0 = (C_{\uparrow}((C/N_0)_{OI}^{-1} - (C/N_0)_{\downarrow}^{-1}) - N_{0\uparrow}) / (1 + Lps(C/N)_{\downarrow}^{-1}) \quad (\text{numeric}) \quad (6)$$

$(C/N_0)_{OI}$  is 36.8 dB(Hz) (see equation (1)),  $C_{\uparrow}$  is -157.3 dB,  $(C/N_0)_{\downarrow}$  is 42.5 dB(Hz),  $N_{0\uparrow}$  is -198.6,  $Lps$  is -15.3, and  $(C/N)_{\downarrow}$  is 42.5 dB(Hz) minus  $10 \log(80 \text{ k})$  or -6.5 dB. Substituting these numeric values into equation (6) yields:

$$I_0 = -198.9 \text{ dB(W/Hz)}$$

It is desirable to characterize the protection criteria in terms of the spfd interference threshold specified in dB(W/(m<sup>2</sup> · Hz)) at the input to the satellite 406 MHz receive antenna. The effective aperture of an antenna,  $A_e$ , having a gain of  $G$  is  $A_e = G \lambda^2 / 4\pi$ . For a LEO receive antenna with the gain of -3.4 dB, the effective aperture is 0.02 m<sup>2</sup>. Therefore, the maximum acceptable aggregate interference specified as an spfd is:

$$spfd = I_0 - L_{Line} - A_e$$

Assuming line losses of 0.6 dB (see Fig. 6):

$$spfd = -198.9 + 0.6 - 10 \log(0.02) = -181.3 \text{ dB(W/(m}^2 \cdot \text{Hz))}$$

The maximum level of broadband noise-like interference in the 406-406.1 MHz band measured at the LEO satellite antenna shall not exceed -181.3 dB(W/m<sup>2</sup> · Hz).

### 3 Procedure for computing the level of interference to the 406 MHz LEOSAR repeater channel

Interference to Cospas-Sarsat is most often a result of out-of-band emissions from services in adjacent or near adjacent bands.

The emission bandwidth must be examined to determine if energy is transmitted in the 406-406.1 MHz band. Particular care must be taken when analysing the impact of mobile systems (e.g. non-geostationary satellites and airborne transmitters) to take into account the effects of the Doppler shift generated by their movement.

Compute the level of interference from all sources that transmit energy in the band 406-406.1 MHz expressed as an spfd level at the satellite antenna. The aggregate level for all interfering sources must not exceed  $-181.3 \text{ dB(W/(m}^2 \cdot \text{Hz))}$  anywhere in this range.

## Annex 6

### Protection criteria in the 406-406.1 MHz band for GOES GEOSAR services

#### 1 Minimum acceptable performance for the detection of EPIRB signals relayed through the GOES 406 MHz SARR channel

To reliably detect 406 MHz distress beacons using GOES 406 MHz satellite repeaters, the BER of the channel must not exceed  $5 \times 10^{-5}$ .

#### 2 Analysis of spfd that causes interference

The BER of a communications channel is derived from the ratio of the energy contained in each data bit,  $E_b$ , to the noise density. The noise density being comprised of the noise developed by Cospas-Sarsat equipment,  $N_0$ , and the noise caused by interference from other systems,  $I_0$ . Figure 7 depicts the GOES 406 MHz SARR channel with interference on the uplink.

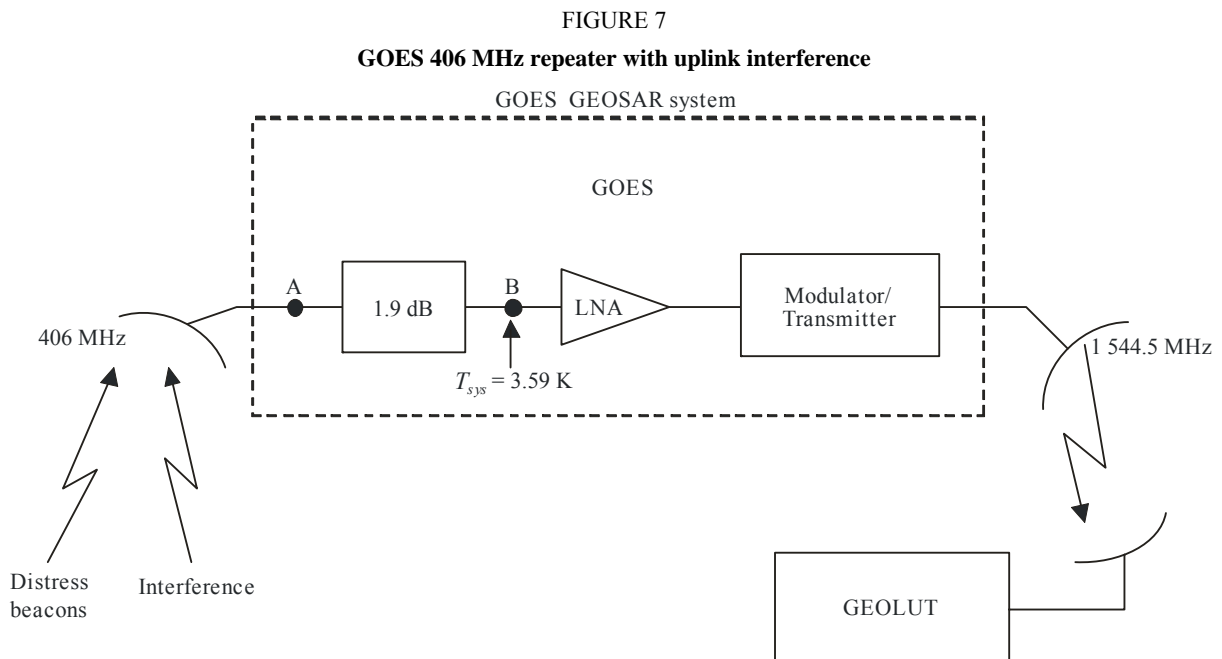

To achieve a BER of  $5 \times 10^{-5}$ , the ratio of the energy per bit to noise plus interference density  $E_b/(N_0 + I_0)$  at the GEOLUT demodulator must equal or exceed 8.8 dB. This analysis determines the maximum amount of broadband noise-like interference specified as an spfd referenced to the input to the GOES 406 MHz satellite antenna that could be accommodated without degrading the overall link  $E_b/(N_0 + I_0)$  below 8.8 dB.

As depicted in Fig. 7, 406 MHz distress beacon signals received by the GOES search and rescue repeater and phase modulated onto a 1544.5 MHz downlink carrier for detection and processing by GEOLUTs. The antenna gain and system noise temperature for the satellite repeater is 7.05 dB and 359 K at point B (Fig. 7). By using sophisticated digital signal processing and burst integration techniques, when there is no interference the overall carrier to noise density ratio,  $C/N_0$ , equals 31.1 dB(Hz).

This analysis assumes three simultaneously active beacons transmitting at the exact same time on three different frequencies in the 406-406.1 MHz band in order to represent a realistic operational environment. The desired beacon has an elevation angle of  $5^\circ$  with respect to the spacecraft. The two other beacons are included in the analysis because they share the available satellite repeater power.

When no external sources of interference are present, the overall  $C/N_0$  is 31.1 dB(Hz), which equates to an  $E_b/N_0$  of 5.1 dB. Accounting for implementation and beacon data demodulation losses and processing gain, the effective ratio of  $E_b/N_0$  is 10.1 dB. Since the channel requires an overall  $E_b/(N_0 + I_0)$  of at least 8.8 dB to operate effectively, the accumulation of broadband interference on the uplink that reduces the overall carrier-to-noise plus interference density ratio by more than 1.3 dB cannot be accommodated.

Since the  $C/N_0$  overall in the absence of interference equates to 31.1 dB(Hz), broadband noise-like interference on the uplink that degrades the overall link by 1.3 dB, would result in an  $(C/N_0)_{overall \text{ with interference}}$  of:

$$\begin{aligned} (C/N_0)_{overall \text{ with interference}} &= (C/N_0)_{OI} = (C/N_0)_{overall} - 1.3 \text{ dB} \\ (C/N_0)_{OI} &= 31.1 \text{ dB(Hz)} - 1.3 \text{ dB} \\ (C/N_0)_{OI} &= 29.8 \text{ dB(Hz)} \end{aligned} \quad (7)$$

The  $(C/N_0)_{OI}$  is calculated from the carrier to noise plus interference density ratios of the uplink and downlink as indicated below:

$$(C/N_0)_{OI} = ((C/N_0)_{up \text{ with interference}}^{-1} + (C/N_0)_{down \text{ with interference}}^{-1})^{-1} \quad (\text{numeric}) \quad (8)$$

Since this analysis concerns interference on the uplink,  $(C/N_0)_{up \text{ with interference}}$  in equation (8) becomes:

$$(C/N_0)_{up \text{ with interference}} = (C_{\uparrow}/(N_{0\uparrow} + I_0)) \quad (\text{numeric}) \quad (9)$$

The interferer also affects the downlink carrier to noise density ratio,  $(C/N_0)_{\downarrow}$ , by increasing the total power shared within the SAR bandwidth. This increased total power decreases the power sharing loss and affects the  $(C/N_0)_{\downarrow}$ , as follows:

$$(C/N_0)_{down \text{ with interference}} = (C/N_0)_{\downarrow} \times (L_{psi}/L_{ps}) \quad (\text{numeric}) \quad (10)$$



where  $Lps$  is the power sharing loss without interference and  $Lpsi$  is the power sharing loss with interference.  $Lpsi$  is calculated as follows:

$$Lpsi = C_{\uparrow} / (C_{\uparrow} + 2 \times C2 + N_{\uparrow} + I_0 B) \quad (\text{numeric}) \quad (11)$$

where  $C2$  is the power level from one of the two other beacon simultaneously received by the GOES SARR and  $B$  is the bandwidth of the GOES receiver.

Substituting equation (11) into equation (10) and then substituting equations (9) and (10) into equation (8) and solving for  $I_0$  results in the following formula:

$$I_0 = (C_{\uparrow} ((C/N_0)_{OI}^{-1} - (C/N_0)_{\downarrow}^{-1}) - N_{0\uparrow}) / (1 + Lps(C/N)_{\downarrow}^{-1}) \quad (\text{numeric}) \quad (12)$$

$(C/N_0)_{OI}$  is 29.8 dB(Hz) (see equation (7)),  $C_{\uparrow}$  is -171.7 dBW,  $(C/N_0)_{\downarrow}$  is 43.8 dB(Hz),  $N_{0\uparrow} = -203$  dB(W/Hz),  $Lps$  is -18.3 dB, and  $(C/N)_{\downarrow}$  is 43.8 dB(Hz) minus  $10 \log(80 \text{ k})$  or -5.2 dB. Substituting these numeric values into equation (12) yields:

$$I_0 = (10^{-171.7/10} (10^{-29.8/10} - 10^{-43.8/10}) - 10^{-203/10}) / (1 + 10^{-18.3/10} \times 10^{5.2/10})$$

or:

$$I_0 = -207.7 \text{ dB(W/Hz)}$$

It is desirable to characterize the protection criteria in terms of the spfd interference threshold specified in dB(W/(m<sup>2</sup> · Hz)) at the input to the satellite 406 MHz receive antenna. The effective aperture of an antenna,  $A_e$ , having a gain of  $G$  is  $A_e = G \lambda^2 / 4\pi$ . For a GOES receive antenna with the gain of 8.95 dB, the effective aperture is 0.341 m<sup>2</sup>. Therefore, the maximum acceptable aggregate interference specified as an spfd is:

$$spfd = I_0 - L_{line} - A_e$$

Assuming line losses of 1.9 dB (see Fig. 7):

$$spfd = -207.7 + 1.9 - 10 \log(0.341) = -201.1 \text{ dB(W/(m}^2 \cdot \text{Hz))}$$

The maximum level of broadband noise-like interference in the 406-406.1 MHz band measured at the GOES satellite antenna shall not exceed -201.1 dB(W/(m<sup>2</sup> · Hz)).

### 3 Procedure for computing level of interference to the GOES 406 MHz SARR channel

Interference to Cospas-Sarsat is most often a result of out-of-band emissions from services in adjacent or near adjacent bands.

The emission bandwidth must be examined to determine if energy is transmitted in the 406-406.1 MHz band. Particular care must be taken when analysing the impact of mobile systems (e.g. non-geostationary satellites and airborne transmitters) to take into account the effects of the Doppler shift generated by their movement.

Compute the level of interference from all sources that transmit energy in the band expressed as an spfd level at the satellite antenna. The aggregate level for all interfering sources must not exceed  $-201.1 \text{ dB(W/(m}^2 \cdot \text{Hz))}$  anywhere in this range.

## Annex 7

### Protection criteria in the 406-406.1 MHz band for MSG GEOSAR services

#### 1 Minimum acceptable performance for the detection of EPIRB signals relayed through the MSG 406 MHz SARR channel

To reliably detect 406 MHz distress beacons using MSG 406 MHz satellite repeaters, the BER of the channel must not exceed  $5 \times 10^{-5}$ .

#### 2 Analysis of spfd that causes interference

The BER of a communications channel is derived from the ratio of the energy contained in each data bit,  $E_b$ , to the noise density. The noise density being comprised of the noise developed by Cospas-Sarsat equipment,  $N_0$ , and the noise caused by interference from other systems,  $I_0$ . Figure 8 depicts the MSG 406 MHz SARR channel with interference on the uplink.

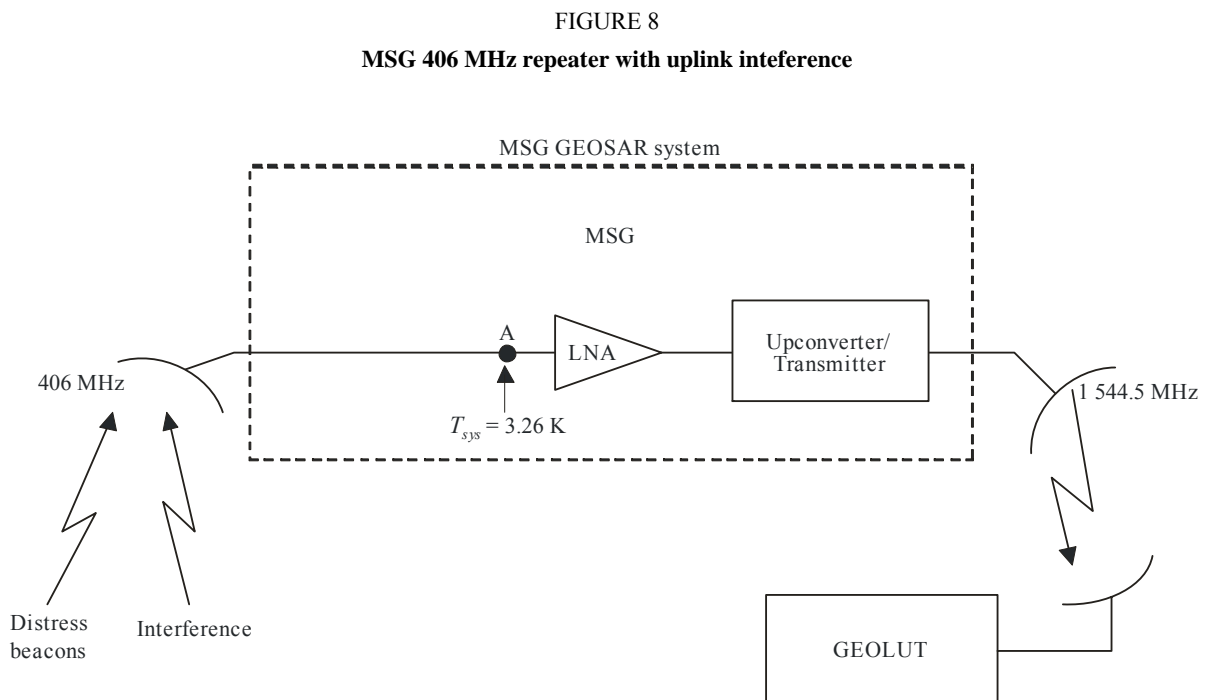

To achieve a BER of  $5 \times 10^{-5}$ , the ratio of the energy per bit to noise plus interference density  $E_b/(N_0 + I_0)$  at the GEOLUT demodulator must equal or exceed 8.8 dB. This analysis determines the maximum amount of broadband noise-like interference specified as an spfd referenced to the input to the MSG 406 MHz satellite antenna that could be accommodated without degrading the overall link  $E_b/(N_0 + I_0)$  below 8.8 dB.

As depicted in Fig. 8, 406 MHz distress beacon signals received by the MSG search and rescue repeater and phase modulated onto a 1 544.5 MHz downlink carrier for detection and processing by GEOLUTs. The antenna gain and system noise temperature for the satellite repeater is 3 dB and 326 K at point A (see Fig. 8). By using sophisticated digital signal processing and burst integration techniques, when there is no interference the overall carrier-to-noise density ratio,  $C/N_0$ , equals 27.4 dB(Hz).

This analysis assumes three simultaneously active beacons transmitting at the exact same time on three different frequencies in the 406-406.1 MHz band in order to represent a realistic operational environment. The desired beacon has an elevation angle of  $5^\circ$  with respect to the spacecraft. The two other beacons are included in the analysis because they share the available satellite repeater power.

When no external sources of interference are present, the overall  $C/N_0$  is 27.4 dB(Hz), which equates to an  $E_b/N_0$  of 1.4 dB. Accounting for implementation and beacon data demodulation losses and processing gain, the effective ratio of  $E_b/N_0$  is 8.9 dB. Since the channel requires an overall  $E_b/(N_0 + I_0)$  of at least 8.8 dB to operate effectively, the accumulation of broadband interference on the uplink that reduces the overall carrier to noise plus interference density ratio by more than 0.1 dB cannot be accommodated.

Since the  $C/N_0$  overall in the absence of interference equates to 27.4 dB(Hz), broadband noise-like interference on the uplink that degrades the overall link by 0.1 dB, would result in an  $(C/N_0)_{overall \text{ with interference}}$  of:

$$(C/N_0)_{overall \text{ with interference}} = (C/N_0)_{OI} = (C/N_0)_{overall} - 0.1 \text{ dB}$$

$$(C/N_0)_{OI} = 27.4 \text{ dB(Hz)} - 0.1 \text{ dB}$$

$$(C/N_0)_{OI} = 27.3 \text{ dB(Hz)}$$

The overall carrier-to-noise plus interference density ratio can be calculated from the carrier-to-noise plus interference density ratios of the uplink and downlink as indicated below:

$$(C/N_0 + I_0)_{overall} = ((C/N_0 + I_0)^{-1}_{\uparrow} + (C/N_0 + I_0)^{-1}_{\downarrow})^{-1}$$

Since this analysis only concerns interference on the uplink, it is assumed that there is no interference on the downlink, the equation simplifies to:

$$(C/N_0 + I_0)_{overall} = ((C/N_0 + I_0)^{-1}_{\uparrow} + (C/N_0)^{-1}_{\downarrow})^{-1}$$

Substituting the values for  $(C/N_0 + I_0)_{overall}$  (27.3 dB(Hz)) and  $(C/N_0)_{\downarrow}$  (35.5 dB(Hz)), the value of the worst-case acceptable carrier-to-noise plus interference density ratio  $((C/N_0 + I_0)_{\uparrow})$  is 28 dB(Hz):

$$C/(N_0 + I_0)_{\uparrow} = ((C/N_0 + I_0)_{overall}^{-1} - (C/N_0)_{\downarrow}^{-1})^{-1}$$

or:

$$C/(N_0 + I_0)_{\uparrow} = 10 \log((10^{-27.3/10} - 10^{-35.5/10})^{-1})$$

then:

$$C/(N_0 + I_0)_{\uparrow} = 28 \text{ dB(Hz)}$$

Solving for  $I_0$  yields:

$$I_0 = 10 \log(10^{(C_{\uparrow} - (C/(N_0 + I_0)_{\uparrow})/10)} - 10^{(N_0(\uparrow)/10)})$$

The noise power spectral density of the uplink without interference at point A is  $N_0 = k T$ , where  $k$  is Boltzmann's constant and  $T$  is the repeater noise temperature referenced to point A. Therefore,  $N_{0\uparrow} = -228.6 + 25.1 = -203.5 \text{ dB(W/Hz)}$ . The uplink carrier power is  $C_{\uparrow} = -175.7 \text{ dBW}$ . Therefore, the maximum acceptable value for the noise density in the uplink ( $I_0$ ) $_{\uparrow}$  is:

$$(I_0)_{\uparrow} = 10 \log(10^{(-175.7 - 28)/10} - 10^{(-203.5/10)})$$

or:

$$(I_0)_{\uparrow} = -217 \text{ dB(W/Hz)}$$

It is desirable to characterize the protection criteria in terms of the spfd interference threshold specified in  $\text{dB(W/m}^2 \cdot \text{Hz)}$  at the input to the satellite 406 MHz receive antenna. The effective aperture of an antenna,  $A_e$ , having a gain of  $G$  is  $A_e = G \lambda^2/4\pi$ . For MSG receive antennas with gains of 3 dB the effective aperture is  $0.087 \text{ m}^2$ . Therefore, the maximum acceptable aggregate interference specified as an spfd is:

$$\text{spfd} = I_0(\text{max}) - A_e$$

$$\text{spfd} = -217 - 10 \log(0.087) = -206.4 \text{ dB(W/(m}^2 \cdot \text{Hz))}$$

The maximum level of broadband noise-like interference in the 406-406.1 MHz band measured at the MSG satellite antenna shall not exceed  $-206.4 \text{ dB(W/(m}^2 \cdot \text{Hz))}$ .

### 3 Procedure for computing level of interference to the MSG 406 MHz SARR channel

Interference to Cospas-Sarsat is most often a result of out-of-band emissions from services in adjacent or near adjacent bands.

The emission bandwidth must be examined to determine if energy is transmitted in the 406-406.1 MHz band. Particular care must be taken when analysing the impact of mobile systems (e.g. non-geostationary satellites and airborne transmitters) to take into account the effects of the Doppler shift generated by their movement.

Compute the level of interference from all sources that transmit energy in the band expressed as an spfd level at the satellite antenna. The aggregate level for all interfering sources must not exceed  $-206.4 \text{ dB(W/(m}^2 \cdot \text{Hz))}$  anywhere in this range.

## Annex 8

### Protection criteria for Cospas-Sarsat search and rescue instruments in the band 406-406.1 MHz (SAR/Electro satellites)

#### 1 Introduction

Cospas-Sarsat search and rescue repeaters on board Electro satellites receive signals from 406 MHz distress beacons and relay the signals to Cospas-Sarsat GEOLUTs on downlink frequencies in the 1 544-1 545 MHz band. The analysis provided in this Annex establishes interference protection criteria in 406.0-406.1 MHz band for Electro GEOSAR services.

#### 2 Minimum acceptable performance for detection of 406 MHz distress beacon signals relayed through Electro satellites

To reliably detect 406 MHz distress beacons using Electro 406 MHz satellite repeaters, the BER of the channel must not exceed  $5 \times 10^{-5}$ .

#### 3 Analysis of interference spfd

The BER of a communication channel is derived from the ratio of the energy contained in each data bit,  $E_b$ , to the noise density. The total noise density is comprised of the noise developed by Cospas-Sarsat equipment,  $N_0$ , and noise caused by interference from other systems,  $I_0$ . Figure 9 depicts the Electro 406 MHz SAR payload channel with interference on the uplink.

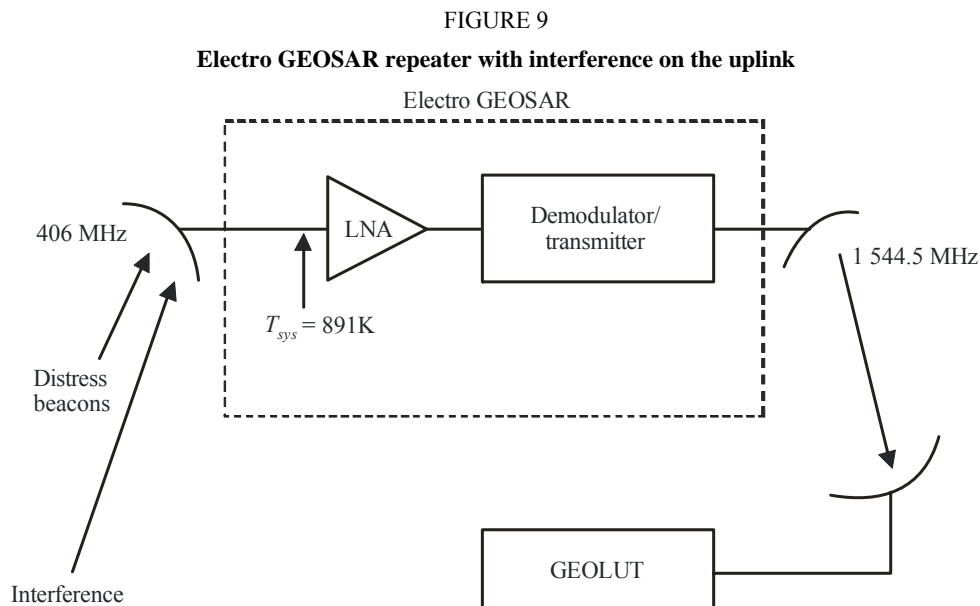



To achieve a BER of  $5 \times 10^{-5}$ , the ratio of the energy per bit to noise plus interference density ( $E_b/(N_0 + I_0)$ ) at the GEOLUT demodulator must equal or exceed 8.8 dB. This analysis determines the maximum amount of broadband noise-like interference specified as a spfd referenced to the input to the Electro 406 MHz satellite antenna, that could be accommodated without degrading the overall link  $E_b/(N_0 + I_0)$  below 8.8 dB.

This analysis assumes three simultaneously active beacons transmitting at the exact same time on three different frequencies in the 406.0-406.1 MHz band. The “low-level” beacon, which is the subject of the analysis, has an elevation angle of 5 degrees with respect to the spacecraft. The two other beacons transmit at “nominal levels” and at elevation angles of 40 degrees with respect to the spacecraft. The two “nominal level” beacons are included in the analysis because they share the available satellite repeater power, and therefore affect the link budget.

As seen in Figure 9, 406 MHz distress beacon signals are received by the Electro SAR. Payload phase modulated and transmitted to a downlink of 1 544.5 MHz for detection and processing by GEOLUTs. The antenna gain and system noise temperature for the satellite repeater are 12 dBi and 891 K (29.5 dB-K), respectively. The corresponding  $G/T$  is  $-17.5$  dB/K.

The beacon signal of 3 dBW e.i.r.p. has an elevation angle of  $5^\circ$  with respect to the spacecraft. When no external sources of interference are present, the overall  $C/N_0$  is 32.2 dB-Hz, for which 400 bit/s equates to an  $E_b/N_0$  of 6.2 dB (32.2 dB-Hz  $-$  26 dB/s). Accounting for implementation losses (1.0 dB), beacon data modulation losses (1.0 dB) and processing gain (7.0 dB) at the GEOLUT, results in an effective ratio of  $E_b/N_0$  of 11.2 dB. Since the channel requires an overall  $E_b/(N_0 + I_0)$  of at least 8.8 dB to reliably meet minimum performance, the accumulation of broadband interference on the uplink that reduces the overall carrier to noise plus interference density ratio by more than 2.4 dB cannot be accommodated.

Since the overall  $C/N_0$  in the absence of interference equates to 32.2 dB-Hz, broadband noise like interference on the uplink that degrades the overall link by 2.4 dB, would result in an  $(C/N_0)_{overall \text{ with interference}}$  of:

$$\begin{aligned} (C/N_0)_{overall \text{ with interference}} &= (C/N_0)_{OI} = (C/N_0)_{overall} - 2.4 \text{ dB} \\ &= 32.2 \text{ dB-Hz} - 2.4 \text{ dB} = 29.8 \text{ dB-Hz} \\ (C/N_0)_{OI} &= 29.8 \text{ dB-Hz} \end{aligned} \quad (1)$$

The  $(C/N_0)_{OI}$  is calculated from the carrier to noise plus interference density ratios of the uplink and downlink as indicated below:

$$(C/N_0)_{OI} = ((C/N_0)_{up \text{ with interference}}^{-1} + (C/N_0)_{down \text{ with interference}}^{-1})^{-1} \text{ (numeric)} \quad (2)$$

Since this analysis only concerns interference on the uplink,  $(C/N_0)_{up \text{ with interference}}$  in equation (2) becomes:

$$(C/N_0)_{up \text{ with interference}} = (C_\uparrow / (N_0\uparrow + I_0)) \text{ (numeric)} \quad (3)$$

The interferer also affects the downlink carrier to noise density ratio,  $(C/N)_\downarrow$ , by increasing the total power shared within the SAR bandwidth. This increased total power decreases the power sharing loss and affects the  $(C/N)_\downarrow$ , as follows:

$$(C/N_0)_{down \text{ with interference}} = (C/N)_\downarrow \times (L_{psi}/L_{ps}) \text{ (numeric)} \quad (4)$$

Where  $L_{ps}$  is the power sharing loss without interference and  $L_{psi}$  is the power sharing loss with interference.  $L_{psi}$  is calculated as follows:

$$L_{psi} = C_\uparrow / (C_\uparrow + 2 \times C_2 + N_\uparrow + I_0B) \text{ (numeric)} \quad (5)$$

where  $C_2$  is the power level from one of the two other beacons simultaneously received by the Electro SARR and  $B$  is the bandwidth of the Electro receiver.

Substituting equation (5) into equation (4) and then substituting equations (3) and (4) into equation (2) and solving for  $I_0$  results in the following formula:

$$I_0 = (C_{\uparrow} ((C/N_0)_{OI}^{-1} - (C/N_0)_{\downarrow}^{-1}) - N_{0\uparrow}) / (1 + Lps (C/N)_{\downarrow}^{-1}) \quad \text{(numeric)} \quad (6)$$

$C_2$  is  $-161.1$  dBW,  $B$  is  $80$  kHz,  $(C/N_0)_{OI}$  is  $29.8$  dB(Hz),  $C_{\uparrow}$  is  $-166.8$  dBW,  $(C/N_0)_{\downarrow}$  is  $48.5$  dB(Hz),  $N_{0\uparrow} = -199.1$  dB(W/Hz),  $Lps$  is  $-17.4$  dB, and  $(C/N)_{\downarrow}$  is  $48.5$  dB(Hz) minus  $10 \log(80k)$  or  $-0.53$  dB. Substituting these numeric values into equation (6) yields:

$$I_0 = (10^{-166.8/10} (10^{-29.8/10} - 10^{-48.5/10}) - 10^{-199.1/10}) / (1 + 10^{-17.4/10} \times 10^{0.53/10})$$

$$I_0 = -200.3 \text{ dB(W/Hz)}$$

It is desirable to characterize the protection criteria in terms of the spfd interference threshold specified in  $\text{dB(W/m}^2 \cdot \text{Hz)}$  at the input to the satellites  $406$  MHz antenna. The effective aperture of an antenna,  $A_e$ , having a gain of  $G$  is  $A_e = G\lambda^2/4\pi$ . Electro antenna has a gain of  $12$  dBi, therefore, the effective aperture is  $0.7 \text{ m}^2$ . The maximum acceptable aggregate interference specified as a spfd is:

$$spfd = I_0 - L_{Line} - A_e$$

Assuming  $L_{Line} = 0$ :

$$spfd = -200.3 - 0 - 10 \log(0.7)$$

$$spfd = -198.7 \text{ dB(W/(m}^2 \cdot \text{Hz))}$$

The maximum level of broadband noise-like interference in the  $406$ - $406.1$  MHz band measured at the Electro satellite antenna input shall not exceed  $-198.7 \text{ dB(W/(m}^2 \cdot \text{Hz))}$ .

#### 4 Procedure for computing the level of interference to the 406 MHz SAR/Electro channel

Interference to Cospas-Sarsat is most often a result of out-of-band emissions from services in adjacent or near adjacent bands.

The emission bandwidth must be examined to determine if energy is transmitted in the  $406$ - $406.1$  MHz band. Particular care must be taken when analysing the impact of mobile systems (e.g. non-geostationary satellites and airborne transmitters) to take into account the effects of the Doppler shift generated by their movement.

Compute the level of interference from all sources that transmit energy in the band  $406$ - $406.1$  MHz expressed as an spfd level at the satellite antenna. The aggregate level for all interfering sources must not exceed  $-198.7 \text{ dB(W/(m}^2 \cdot \text{Hz))}$  anywhere in this range.

## Annex 9

### Protection criteria for Cospas-Sarsat search and rescue instruments in the band 406-406.1 MHz (SAR/GLONASS)

#### 1 Introduction

Cospas-Sarsat search and rescue repeaters onboard GLONASS satellites receive signals from 406 MHz distress beacons and relay the signals to Cospas-Sarsat MEOLUTs on downlink frequencies in the 1 544-1 545 MHz band. The analysis provided in this Annex establishes interference protection criteria in the 406.0-406.1 MHz band for GLONASS MEOSAR services.

#### 2 Minimum acceptable performance for detection of 406 MHz distress beacon signals relayed through GLONASS satellites

To reliably detect 406 MHz distress beacons using GLONASS 406 MHz satellite repeaters, the BER of the channel must not exceed  $5 \times 10^{-5}$ .

#### 3 Analysis of interference spfd

The BER of a communication channel is derived from the ratio of the energy contained in each data bit,  $E_b$ , to the noise density. The total noise density is comprised of the noise developed by Cospas-Sarsat equipment,  $N_0$ , and noise caused by interference from other systems,  $I_0$ . Figure 10 depicts the GLONASS 406 MHz SAR payload channel with interference on the uplink.

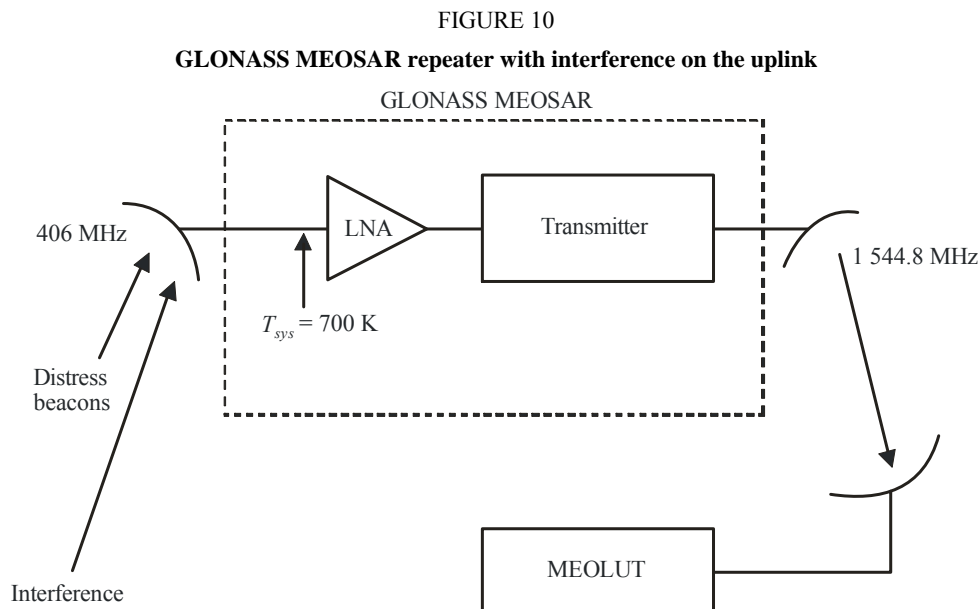

M.1478-10

To achieve a BER of  $5 \times 10^{-5}$ , the ratio of the energy per bit to noise plus interference density ( $E_b/(N_0 + I_0)$ ) at the MEOLUT demodulator must equal or exceed 8.8 dB. This analysis determines the maximum amount of broadband noise-like interference specified as a spfd referenced to the input to the GLONASS 406 MHz satellite antenna, that could be accommodated without degrading the overall link  $E_b/(N_0 + I_0)$  below 8.8 dB.

This analysis assumes three simultaneously active beacons transmitting at the exact same time on three different frequencies in the 406.0-406.1 MHz band. The “low-level” beacon, which is the subject of the analysis, has an elevation angle of 5 degrees with respect to the spacecraft. The two other beacons transmit at “nominal levels” and at elevation angles of 40 degrees with respect to the spacecraft. The two “nominal level” beacons are included in the analysis because they share the available satellite repeater power, and therefore affect the link budget.

As seen in Figure 10, 406 MHz distress beacon signals are received by the GLONASS SAR payload and transmitted to a downlink of 1 544.8 MHz for detection and processing by MEOLUTs. The antenna gain and system noise temperature for the satellite repeater are 11.5 dBi and 700 K (28.5 dB-K), respectively. The corresponding  $G/T$  is  $-17.0$  dB/K.

The beacon signal has an elevation angle of 5 degrees with respect to the spacecraft. When no external sources of interference are present, the overall  $C/N_0$  is 35.5 dB-Hz, which for 400 bit/s equates to an  $E_b/N_0$  of 9.5 dB (35.5 dB-Hz  $-$  26 dB/s). Accounting for implementation losses (1.0 dB), beacon data modulation losses (1.0 dB) and processing gain (2.0 dB) at the MEOLUT, results in an effective ratio of  $E_b/N_0$  of 9.5 dB. Since the channel requires an overall  $E_b/(N_0 + I_0)$  of at least 8.8 dB to reliably meet minimum performance, the accumulation of broadband interference on the uplink that reduces the overall carrier-to-noise plus interference density ratio by more than 0.7 dB cannot be accommodated.

Since the overall  $C/N_0$  in the absence of interference equates to 35.5 dB-Hz, broadband noise-like interference on the uplink that degrades it by 0.7 dB, would result in an overall carrier-to-noise plus interference density ratio  $(C/(N_0+I_0))_{overall}$  of:

$$\begin{aligned} (C/(N_0+I_0))_{overall} &= (C/N_0)_{overall} - 0.7 \text{ dB} \\ &= 35.5 \text{ dB-Hz} - 0.7 \text{ dB} \\ &= 34.8 \text{ dB-Hz} \end{aligned} \quad (1)$$

The  $(C/N_0)_{OI}$  is calculated from the carrier-to-noise plus interference density ratios of the uplink and downlink as indicated below:

$$(C/N_0)_{OI} = ((C/N_0)_{up \text{ with interference}}^{-1} + (C/N_0)_{down \text{ with interference}}^{-1})^{-1} \text{ (numeric)} \quad (2)$$

Since this analysis only concerns interference on the uplink,  $(C/N_0)_{up \text{ with interference}}$  in equation (2) becomes:

$$(C/N_0)_{up \text{ with interference}} = (C_{\uparrow}/(N_{0\uparrow} + I_0)) \text{ (numeric)} \quad (3)$$

The interferer also affects the downlink carrier-to-noise density ratio,  $(C/N)_{\downarrow}$ , by increasing the total power shared within the SAR bandwidth. This increased total power decreases the power sharing loss and affects the  $(C/N)_{\downarrow}$ , as follows:

$$(C/N_0)_{down \text{ with interference}} = (C/N)_{\downarrow} \times (Lpsi/Lps) \text{ (numeric)} \quad (4)$$

Where  $Lps$  is the power sharing loss without interference and  $Lpsi$  is the power sharing loss with interference.  $Lpsi$  is calculated as follows:

$$Lpsi = C_{\uparrow}/(C_{\uparrow} + 2 \times C_2 + N_{\uparrow} + I_0B) \text{ (numeric)} \quad (5)$$

where  $C_2$  is the power level from one of the two other beacon simultaneously received by the GLONASS SARR and  $B$  is the bandwidth of the GLONASS receiver.

Substituting equation (5) into equation (4) and then substituting equations (3) and (4) into equation (2) and solving for  $I_0$  results in the following formula:

$$I_0 = (C_{\uparrow}((C/N_0)_{OI}^{-1} - (C/N_0)_{\downarrow}^{-1}) - N_{0\uparrow}) / (1 + Lps(C/N)_{\downarrow}^{-1}) \text{ (numeric)} \quad (6)$$

$C_2$  is  $-158.5$  dBW,  $B$  is  $80$  kHz,  $(C/N_0)_{OI}$  is  $34.8$  dB(Hz),  $C_{\uparrow}$  is  $-164.3$  dBW,  $(C/N_0)_{\downarrow}$  is  $47.6$  dB(Hz),  $N_{0\uparrow} = -200.2$  dB(W/Hz),  $L_{ps}$  is  $-14.7$  dB, and  $(C/N)_{\downarrow}$  is  $47.6$  dB(Hz) minus  $10 \log(80k)$  or  $-1.4$  dB. Substituting these numeric values into equation (6) yields:

$$I_0 = (10^{-164.3/10} (10^{-34.8/10} - 10^{-47.6/10}) - 10^{-200.2/10}) / (1 + 10^{-14.7/10} \times 10^{1.4/10})$$

$$I_0 = -207.3 \text{ dB(W/Hz)}$$

It is desirable to characterize the protection criteria in terms of the spfd interference threshold specified in dB(W/m<sup>2</sup> · Hz) at the input to the satellites 406 MHz antenna. The effective aperture of an antenna,  $A_e$ , having a gain of  $G$  is  $A_e = G\lambda^2/4\pi$ . The GLONASS receive antenna has a gain of  $11.5$  dBi, therefore, the effective aperture is  $0.61$  m<sup>2</sup>. The maximum acceptable aggregate interference specified as a spfd is:

$$spfd = I_0 - L_{LINE} - A_e$$

Assuming  $L_{LINE} = 0$ :

$$spfd = -207.3 - 0 - 10 \log(0.61)$$

$$spfd = -205.2 \text{ dB(W/(m}^2 \cdot \text{Hz))}$$

The maximum level of broadband noise-like interference in the 406-406.1 MHz band measured at the GLONASS satellite antenna input shall not exceed  $-205.2$  dB(W/(m<sup>2</sup> · Hz)).

#### 4 Procedure for computing the level of interference to the 406 MHz SAR/GLONASS channel

Interference to Cospas-Sarsat is most often a result of out-of-band emissions from services in adjacent or near adjacent bands.

The emission bandwidth must be examined to determine if energy is transmitted in the 406-406.1 MHz band. Particular care must be taken when analysing the impact of mobile systems (e.g. non-geostationary satellites and airborne transmitters) to take into account the effects of the Doppler shift generated by their movement.

Compute the level of interference from all sources that transmit energy in the band 406-406.1 MHz expressed as spfd level at the satellite antenna. The aggregate level for all interfering sources must not exceed  $-205.2$  dB(W/(m<sup>2</sup> · Hz)) anywhere in this range.