



**Recommendation ITU-R M.493-13**  
**(10/2009)**

**Digital selective-calling system for use  
in the maritime mobile service**

**M Series**  
**Mobile, radiodetermination, amateur and related  
satellite services**

## Foreword

The role of the Radiocommunication Sector is to ensure the rational, equitable, efficient and economical use of the radio-frequency spectrum by all radiocommunication services, including satellite services, and carry out studies without limit of frequency range on the basis of which Recommendations are adopted.

The regulatory and policy functions of the Radiocommunication Sector are performed by World and Regional Radiocommunication Conferences and Radiocommunication Assemblies supported by Study Groups.

## Policy on Intellectual Property Right (IPR)

ITU-R policy on IPR is described in the Common Patent Policy for ITU-T/ITU-R/ISO/IEC referenced in Annex 1 of Resolution ITU-R 1. Forms to be used for the submission of patent statements and licensing declarations by patent holders are available from <http://www.itu.int/ITU-R/go/patents/en> where the Guidelines for Implementation of the Common Patent Policy for ITU-T/ITU-R/ISO/IEC and the ITU-R patent information database can also be found.

### Series of ITU-R Recommendations

(Also available online at <http://www.itu.int/publ/R-REC/en>)

Series	Title
<b>BO</b>	Satellite delivery
<b>BR</b>	Recording for production, archival and play-out; film for television
<b>BS</b>	Broadcasting service (sound)
<b>BT</b>	Broadcasting service (television)
<b>F</b>	Fixed service
<b>M</b>	<b>Mobile, radiodetermination, amateur and related satellite services</b>
<b>P</b>	Radiowave propagation
<b>RA</b>	Radio astronomy
<b>RS</b>	Remote sensing systems
<b>S</b>	Fixed-satellite service
<b>SA</b>	Space applications and meteorology
<b>SF</b>	Frequency sharing and coordination between fixed-satellite and fixed service systems
<b>SM</b>	Spectrum management
<b>SNG</b>	Satellite news gathering
<b>TF</b>	Time signals and frequency standards emissions
<b>V</b>	Vocabulary and related subjects

*Note: This ITU-R Recommendation was approved in English under the procedure detailed in Resolution ITU-R 1.*

Electronic Publication  
Geneva, 2009

© ITU 2009

All rights reserved. No part of this publication may be reproduced, by any means whatsoever, without written permission of ITU.

## RECOMMENDATION ITU-R M.493-13\*

**Digital selective-calling system for use in the maritime mobile service**

(1974-1978-1982-1986-1990-1992-1994-1995-1997-1997-2000-2004-2007-2009)

**Scope**

This Recommendation describes the digital selective-calling (DSC) system for use in the maritime mobile service covering general purpose and simplified versions of DSC equipment. A description of a generalized user interface as well as an automated procedure for the operation of shipborne equipment are also included.

The ITU Radiocommunication Assembly,

*considering*

- a) that selective-calling in the shore-to-ship, ship-to-ship and ship-to-shore directions would expedite the handling of traffic in the maritime mobile service;
- b) that the International Maritime Organization (IMO) has listed a number of operational requirements that should be taken into account when designing a general purpose selective-calling system;
- c) that Chapter IV of the International Convention for the Safety of Life at Sea (SOLAS), 1974, as amended, requires the use of digital selective calling (DSC) for distress alerting and safety calling in the Global Maritime Distress and Safety System (GMDSS);
- d) that neither the selective-calling system described in Recommendation ITU-R M.257, nor that forming part of the systems described in Recommendations ITU-R M.476 and ITU-R M.625, can fully meet the IMO performance standards for shipborne equipment;
- e) that the DSC system should be applicable to the maritime mobile service, both for international and national needs;
- f) that it is desirable that the DSC system fulfils the requirements of all types of vessels desiring to use it;
- g) that after experience gained, a need exists to reduce unnecessary alarms and simplify operation of shipborne equipment;
- h) that in certain applications there may be a need to disable DSC automatic channel switching when there is a requirement for vessels to maintain continuous radio watch on a specific radio telephony channel (e.g. port traffic control, bridge-to-bridge communications),

---

\* This Recommendation should be brought to the attention of the International Maritime Organization (IMO).

*recommends*

- 1 that DSC equipment should be designed in response to the operational requirements specified within Recommendation ITU-R M.541;
- 2 that where there is a need for a general purpose DSC system, the system should be designed in accordance with the characteristics given in Annex 1;
- 3 that where there is a need for simplified versions of DSC equipment, they should be designed in accordance with Annex 2;
- 4 that in a GMDSS coast radio station installation, sufficient separation should be provided between the DSC distress channel receiver antennas and any transmitting antennas within the installation. This is to avoid any de-sensitization of the DSC distress channel receivers if any transmitter is used at full power on any designated transmit frequency other than the DSC distress frequencies;
- 5 that shipborne DSC equipment should be designed to provide a simplified user interface, following the examples of good practice set out in Annexes 3 and 4.

## Annex 1

### General purpose equipment characteristics

#### 1 General

1.1 The system is a synchronous system using characters composed from a ten-bit error-detecting code as listed in Table 1.

1.1.1 The first seven bits of the ten-bit code of Table 1 are information bits. Bits 8, 9 and 10 indicate, in the form of a binary number, the number of B elements that occur in the seven information bits, a Y element being a binary number 1 and a B element a binary number 0. For example, a BYY sequence for bits 8, 9 and 10 indicates 3 ( $0 \times 4 + 1 \times 2 + 1 \times 1$ ) B elements in the associated seven information bit sequence; and a YYB sequence indicates 6 ( $1 \times 4 + 1 \times 2 + 0 \times 1$ ) B elements in the associated seven information bit sequence. The order of transmission for the information bits is least significant bit first but for the check bits it is most significant bit first.

1.2 Time diversity is provided in the call sequence as follows:

1.2.1 Apart from the phasing characters, each character is transmitted twice in a time-spread mode; the first transmission (DX) of a specific character is followed by the transmission of four other characters before the re-transmission (RX) of that specific character takes place, allowing for a time-diversity reception interval of:

1.2.1.1 400 ms for HF and MF channels, and

1.2.1.2  $33\frac{1}{3}$  ms for VHF radio-telephone channels.

**1.3** The classes of emission, frequency shifts and modulation rates are as follows:

**1.3.1** F1B or J2B 170 Hz and modulation rate of 100 Bs (bit/s)  $\pm 30 \times 10^6$  for use on HF and MF DSC calling channels. When frequency-shift keying is effected by applying audio signals to the input of single-sideband transmitters (J2B), the centre of the audio-frequency spectrum offered to the transmitter is 1 700 Hz. When a DSC call is transmitted on HF and MF working channels for public correspondence, the class of emission is J2B. In this case, audio tones with frequencies 1 700 Hz  $\pm 85$  Hz and modulation rate 100 Bs (bit/s)  $\pm 30 \times 10^6$  are used in order for the DSC call to be transmitted.

**1.3.2** Frequency modulation with a pre-emphasis of 6 dB/octave (phase modulation) with frequency-shift of the modulating sub-carrier for use on VHF channels:

- frequency-shift between 1 300 and 2 100 Hz; the sub-carrier being at 1 700 Hz;
- the frequency tolerance of the 1 300 and 2 100 Hz tones is  $\pm 10$  Hz;
- the modulation rate is 1 200 B s (bit/s)  $\pm 30 \times 10^6$ ;
- the index of modulation is  $2.0 \pm 10\%$ .

**1.3.3** The radio-frequency tolerances of new designs of both transmitters and receivers in the MF and HF bands should be:

- coast station:  $\pm 10$  Hz,
- ship station:  $\pm 10$  Hz,
- receiver bandwidth: should not exceed 300 Hz.

**1.4** The higher frequency corresponds to the B-state and the lower frequency corresponds to the Y-state of the signal elements.

**1.5** The information in the call is presented as a sequence of seven-bit combinations constituting a primary code.

**1.5.1** The seven information bits of the primary code express a symbol number from 00 to 127, as shown in Table 1, and where:

**1.5.1.1** the symbols from 00 to 99 are used to code two decimal figures according to Table 2;

**1.5.1.2** the symbols from 100 to 127 are used to code service commands (see Table 3).

**1.6** Where the distress alert repetitions described in § 11 apply, the following conditions are considered necessary:

**1.6.1** the transmitter encoder must provide repetitive transmission of the call sequence in accordance with § 11; and

**1.6.2** the receiver decoder should provide maximum utilization of the received signal, including use of the error-check character and by using an iterative decoding process with adequate memory provision.

**1.7** When the transmission of a DSC distress alert is automatically repeated, ships' DSC equipments must be capable of automatically receiving a subsequent distress acknowledgement (see Recommendation ITU-R M.541, Annex 1, § 3.1.3.1, 3.1.3.2 and 3.3.5).

TABLE 1  
Ten-bit error-detecting code

Symbol No.	Emitted signal and bit position 12345678910	Symbol No.	Emitted signal and bit position 12345678910	Symbol No.	Emitted signal and bit position 12345678910
00	BBBBBBBYYY	43	YYBYBYBBYY	86	BYYBYBYBY
01	YBBBBBBYB	44	BBYYBYBYBB	87	YYYBYBYBY
02	BYBBBBBYB	45	YBYBYBBYY	88	BBYYBYBYB
03	YYBBBBBYB	46	BYYYBYBBYY	89	YBBYYBYBY
04	BBYBBBBYB	47	YYYYBYBBYB	90	BYBYBYBY
05	YBYBBBBYB	48	BBBBYYBYBY	91	YYBYBYBYB
06	BYYBBBBYB	49	YBBYYBYBB	92	BBYYBYBY
07	YYYBBBBYB	50	BYBBYYBYBB	93	YBYYBYBYB
08	BBYBBBBYB	51	YYBBYYBBYY	94	BYYYYBYBY
09	YBBYBBYBY	52	BBYBYBYBB	95	YYYYBYBBY
10	BYBYBBYBY	53	YBYYYBBYY	96	BBBBYYBYB
11	YYBYBBYBB	54	BYYBYBBYY	97	YBBBBYYBB
12	BBYBBYBYB	55	YYYBYBBYB	98	BYBBBBYYB
13	YBYBBYBB	56	BBYYBYBB	99	YBBBBYYBY
14	BYYYYBBYB	57	YBBYYBBYY	100	BBYBBYYBB
15	YYYYBBBYY	58	BYYYBBYY	101	YBYYBYBY
16	BBBBYBBYB	59	YYBYYBBYB	102	BYYBBYBY
17	YBBYBBYBY	60	BBYYBBYY	103	YYYBBYBYB
18	BYBBYBBYB	61	YBYYBBYB	104	BBBYBYBYB
19	YYBBYBBYB	62	BYYYYBBYB	105	YBBYBYBY
20	BBYBYBBYB	63	YYYYBBBYY	106	BYBYBYBY
21	YBYBYBBYB	64	BBBBBBYYYB	107	YYBYBYBYB
22	BYYBYBBYB	65	YBBBBBYBY	108	BBYYBYBY
23	YYYBYBBYY	66	BYBBBBYYBY	109	YBYBYBYB
24	BBYBYBBYB	67	YBBBBYYBB	110	BYYBYBYB
25	YBBYBBYBB	68	BBYBBYBY	111	YYYYBYBBY
26	BYBYBBYBB	69	YBYBBYBB	112	BBBBYYBYB
27	YYBYBBYY	70	BYBBYYBB	113	YBBBBYYBY
28	BBYYBBYBB	71	YYYBBYBY	114	BYBBYYBY
29	YBYYBBYY	72	BBYBBYBY	115	YBBYYBYB
30	BYYYYBBYY	73	YBBYBBYBB	116	BBYBYBY
31	YYYYBBBYB	74	BYBYBBYBB	117	YBYBYBYB
32	BBBBBYBYB	75	YYBYBBYBY	118	BYYBYBYB
33	YBBBBYBYB	76	BBYYBBYBB	119	YYYBYBYBY
34	BYBBYBYBY	77	YBYBBYBY	120	BBYYBYBY
35	YYBBYBYBB	78	BYYBBYBY	121	YBBYYBYB
36	BBYBYBYBY	79	YYYBBYBYB	122	BYBYBYBYB
37	YBYBYBYBB	80	BBBYBYBY	123	YYBYBYBY
38	BYYBYBYBB	81	YBBYBYBB	124	BBYYBYBYB
39	YYYBYBBYY	82	BYBBYYBB	125	YBBBBYYBY
40	BBBYBYBYB	83	YBBYBYBY	126	BYYYYYYBY
41	YBBYBYBYB	84	BBYBYBYBB	127	YYYYYYBBB
42	BYBYBYBYB	85	YBYBYBYBY		

B = 0

Y = 1

Order of bit transmission: bit 1 first.

TABLE 2  
Packing table for decimal numbers into ten-bit characters

The digits for the									
Thousands of millions D2	Hundreds of millions D1	Tens of millions D2	Millions D1	Hundreds of thousands D2	Tens of thousands D1	Thousands D2	Hundreds D1	Tens D2	Units D1
Character 5		Character 4		Character 3		Character 2		Character 1	

NOTE 1 – Character 1 is the last character transmitted.

The digit sequence D2-D1 varies from 00 to 99 inclusive in each character (character 1 to 5 inclusive). The character that represents a particular two-decimal figure is transmitted as the symbol number (see Table 1) that is identical to that particular two-decimal figure.

When the number consists of an odd number of decimal digits, a zero shall be added in front of the most significant position to provide an integral number of ten-bit characters.

TABLE 3  
Use of symbol Nos. 100 to 127

Symbol No.	Phasing and unique functions	Format specifier <sup>(1)</sup>	Category <sup>(1)</sup>	Nature of distress <sup>(1)</sup>	First telecommand <sup>(1)</sup>	Second telecommand <sup>(1)</sup>
100			Routine	Fire, explosion	F3E/G3E All modes TP	No reason given <sup>(2)</sup>
101				Flooding	F3E/G3E duplex TP	Congestion at maritime switching centre
102		Geographical area		Collision		Busy <sup>(2)</sup>
103		<sup>(3)</sup>	<sup>(3)</sup>	Grounding	Polling	Queue indication <sup>(2)</sup>
104	Phasing RX-0 position			Listing, in danger of capsizing	Unable to comply	Station barred <sup>(2)</sup>
105	Phasing RX-1 position			Sinking	End of call <sup>(4)</sup>	No operator available <sup>(2)</sup>
106	Phasing RX-2 position		<sup>(6)</sup>	Disabled and adrift	Data	Operator temporarily unavailable <sup>(2)</sup>
107	Phasing RX-3 position			Undesignated distress		Equipment disabled <sup>(2)</sup>
108	Phasing RX-4 position		Safety	Abandoning ship		Unable to use proposed channel <sup>(2)</sup>
109	Phasing RX-5 position			Piracy/armed robbery attack	J3E TP	Unable to use proposed mode <sup>(2)</sup>
110	Phasing RX-6 position	<sup>(5)</sup>	Urgency	Man overboard	Distress acknowledgement	Ships and aircraft of States not parties to an armed conflict

TABLE 3 (end)

Symbol No.	Phasing and unique functions	Format specifier <sup>(1)</sup>	Category <sup>(1)</sup>	Nature of distress <sup>(1)</sup>	First telecommand <sup>(1)</sup>	Second telecommand <sup>(1)</sup>
111	Phasing RX-7 position				<sup>(6)</sup>	Medical transports (as defined in 1949 Geneva Conventions and additional Protocols)
112		Distress	Distress	EPIRB emission	Distress relay	Pay-phone/public call office
113					F1B/J2B TTY-FEC	Facsimile/data according to Recommendation ITU-R M.1081
114		Ships having common interest				
115					F1B/J2B TTY-ARQ	<sup>(6)</sup>
116		All ships <sup>(7)</sup>			<sup>(6)</sup>	<sup>(6)</sup>
117	Ack. RQ (EOS)				<sup>(6)</sup>	<sup>(6)</sup>
118					Test	<sup>(6)</sup>
119					<sup>(6)</sup>	<sup>(6)</sup>
120		Individual stations			<sup>(6)</sup>	<sup>(6)</sup>
121		Reserved for national non-calling purposes e.g. Report ITU-R M.1159			Ship position or location registration updating	<sup>(6)</sup>
122	Ack. BQ (EOS)				<sup>(6)</sup>	<sup>(6)</sup>
123		Individual station semi-automatic/automatic service			<sup>(6)</sup>	<sup>(6)</sup>
124		<sup>(5)</sup>			<sup>(6)</sup>	<sup>(6)</sup>
125	Phasing DX position				<sup>(6)</sup>	<sup>(6)</sup>
126	*				No information	No information
127	EOS				<sup>(6)</sup>	<sup>(6)</sup>

TP: Telephony

TTY: Direct printing

ARQ: Rec. ITU-R M.476 or Rec. ITU-R M.625 equipment

- <sup>(1)</sup> Unassigned symbols should be rejected. The DSC equipment should take no action.
- <sup>(2)</sup> Currently unassigned when used with first telecommands other than symbol No. 104 – for future use.
- <sup>(3)</sup> Used for selective call to a group of ships in a specified VTS area (Rec. ITU-R M.825). Reception of calls having format specifier 103, for (or) category shall not activate any alarms on shipborne DSC controller. Should not be used in any future expansion.
- <sup>(4)</sup> Only used for semi-automatic/automatic service.
- <sup>(5)</sup> Used in the automatic VHF/UHF service (Rec. ITU-R M.586). Should not be used in any future expansion.
- <sup>(6)</sup> Should not be used in any future expansion.
- <sup>(7)</sup> MF/HF used only for distress alert acknowledgment and coast station receive (see Table 4).



## 2 Technical format of a call sequence

2.1 The technical format of the call sequence is:

Dot pattern See § 3	Phasing sequence See § 3	Call content See Tables 4.1 to 4.10.2	Closing sequence See § 9, § 10 and Fig. 1
------------------------	-----------------------------	--	--

0493-00

2.2 Examples of typical call sequences and the construction of the transmission format are given in Figs. 1 to 3.

2.3 The flow charts illustrating the operation of the DSC system are shown in Figs. 4 and 5.

## 3 Dot pattern and phasing

3.1 The phasing sequence provides information to the receiver to permit correct bit phasing and unambiguous determination of the positions of the characters within a call sequence (see Note 1).

NOTE 1 – Acquisition of character synchronization should be achieved by means of character recognition rather than, for example, by recognizing a change in the dot pattern, in order to reduce false synchronization caused by a bit error in the dot pattern.

3.2 The phasing sequence consists of specific characters in the DX and RX positions transmitted alternatively. Six DX characters are transmitted.

3.2.1 The phasing character in the DX position is symbol No. 125 of Table 1.

3.2.2 The phasing characters in the RX position specify the start of the information sequence (i.e. the format specifier) and consist of the symbol Nos. 111, 110, 109, 108, 107, 106, 105 and 104 of Table 1, consecutively.

3.3 Phasing is considered to be achieved when two DXs and one RX, or two RXs and one DX, or three RXs in the appropriate DX or RX positions, respectively, are successfully received. These three phasing characters may be detected in either consecutive or non-consecutive positions but in both cases all bits of the phasing sequence should be examined for a correct 3-character pattern. A call should be rejected only if a correct pattern is not found anywhere within the phasing sequence.

3.4 To provide appropriate conditions for earlier bit synchronization and to allow for scanning methods to monitor several HF and MF frequencies by ship stations, the phasing sequence should be preceded by a dot pattern (i.e. alternating B-Y or Y-B sequence bit synchronization signals) with duration of:

### 3.4.1 200 bits

At HF and MF for:

- distress alerts;
- distress acknowledgements;
- distress relays addressed to a geographic area;
- distress relay acknowledgements addressed to all ships;
- all calls addressed to a ship station other than those specified in § 3.4.2.

### 3.4.2 20 bits

At HF and MF, for all acknowledgements to individual calls having format specifiers 120 and 123 and for all calling to coast stations. At VHF for all calls.

## 4 Format specifier

**4.1** The format specifier characters which are transmitted twice in both the DX and RX positions (see Fig. 1) are:

**4.1.1** symbol No. 112 for a “distress” alert; or

**4.1.2** symbol No. 116 for an “all ships” call; or

**4.1.3** symbol No. 114 for a selective call to a group of ships having a common interest (e.g. belonging to one particular country, or to a single ship owner, etc.); or

**4.1.4** symbol No. 120 for a selective call to a particular individual station; or

**4.1.5** symbol No. 102 for a selective call to a group of ships in a particular geographic area; or

**4.1.6** symbol No. 123 for a selective call to a particular individual station using the semi-automatic/automatic service.

**4.2** It is considered that receiver decoders must detect the format specifier character twice for “distress” alerts and “all ships” calls to effectively eliminate false alerting. For other calls, the address characters provide additional protection against false alerting and, therefore, single detection of the format specifier character is considered satisfactory (see Table 3).

## 5 Address

**5.1** “Distress” alerts and “all ships” calls do not have addresses since these calls are implicitly addressed to all stations (ship stations and coast stations).

**5.2** For a selective call directed to an individual ship, to a coast station or to a group of stations having a common interest, the address consists of the characters corresponding to the station’s maritime mobile service identity, the sequence consisting of characters coded in accordance with Table 2 (see Note 1).

NOTE 1 – According to RR Article 19, maritime mobile service identities are formed of a series of nine digits, consisting of three digits of the Maritime Identification Digits (MID) and six more digits.

These identities are included in the address and self-identification parts of the call sequence and are transmitted as five characters  $C_5C_4C_3C_2C_1$ , comprising the ten digits of:

$$(X_1, X_2) (X_3, X_4) (X_5, X_6) (X_7, X_8) \text{ and } (X_9, X_{10})$$

respectively, whereas digit  $X_{10}$  is always the figure 0 unless the equipment is also designed in accordance with Recommendation ITU-R M.1080.

*Example:*

MID  $X_4 X_5 X_6 X_7 X_8 X_9$  being the ship station identity is transmitted by the DSC equipment as:

$$(M, I) (D, X_4) (X_5, X_6) (X_7, X_8) (X_9, 0)$$

**5.3** For a selective call directed to a group of ships in a particular geographic area a numerical geographic coordinates address consisting of ten digits (i.e. 5 characters), is constructed as follows (see Fig. 6 and Note 1):

NOTE 1 – In order to comply with commonly accepted practice, the order of entry and read-out should be: first latitude and then longitude.

- 5.3.1 the designated geographic area will be a rectangle in Mercator projection;
- 5.3.2 the upper left-hand (i.e. North-West) corner of the rectangle is the reference point for the area;
- 5.3.3 the first digit indicates the azimuth sector in which the reference point is located, as follows:
  - 5.3.3.1 quadrant NE is indicated by the digit “0”,
  - 5.3.3.2 quadrant NW is indicated by the digit “1”,
  - 5.3.3.3 quadrant SE is indicated by the digit “2”,
  - 5.3.3.4 quadrant SW is indicated by the digit “3”;
- 5.3.4 the second and third digits indicate the latitude of the reference point in tens and units of degrees;
- 5.3.5 the fourth, fifth and sixth digits indicate the longitude of the reference point in hundreds, tens and units of degrees;
- 5.3.6 the seventh and eighth digits indicate the vertical (i.e. North-to-South) side of the rectangle,  $\Delta\phi$ , in tens and units of degrees;
- 5.3.7 the ninth and tenth digits indicate the horizontal (i.e. West-to-East) side of the rectangle,  $\Delta\lambda$ , in tens and units of degrees.

## 6 Category

- 6.1 The “category” information is coded as shown in Table 3 and defines the degree of priority of the call sequence.
- 6.2 For a “distress” alert the priority is defined by the format specifier and no category information is included in the call sequence.
  - 6.2.1 For distress relays, distress relay acknowledgements and distress acknowledgements the category is distress.
- 6.3 For safety related calls, the “category” information specifies:
  - 6.3.1 urgency; or
  - 6.3.2 safety.
- 6.4 For other calls, the “category” information specifies:
  - 6.4.1 routine.

## 7 Self-identification

- 7.1 The maritime mobile service identity (MMSI) assigned to the calling station, coded as indicated in § 5.2 and its Note 1, is used for self-identification.

## 8 Messages

The messages that are included in a call sequence contain the following message elements, which are listed in the order in which they would appear in each message. All message formats are explicitly defined in Tables 4.1 through 4.10.2:

**8.1** For a “distress” alert (see Table 4.1) the distress information is contained in four messages in the following order:

**8.1.1** Message 1 is the “nature of distress” message, coded as shown in Table 3, i.e.:

**8.1.1.1** fire, explosion;

**8.1.1.2** flooding;

**8.1.1.3** collision;

**8.1.1.4** grounding;

**8.1.1.5** listing, in danger of capsizing;

**8.1.1.6** sinking;

**8.1.1.7** disabled and adrift;

**8.1.1.8** undesignated distress;

**8.1.1.9** abandoning ship;

**8.1.1.10** piracy/armed robbery attack;

**8.1.1.11** man overboard;

**8.1.1.12** emergency position-indicating radiobeacon (EPIRB) emission.

**8.1.2** Message 2 is the “distress coordinates” message, consisting of ten digits indicating the location of the vessel in distress, coded on the principles described in Table 2, in pairs starting from the first and second digits (see Note 1 to § 5.3):

**8.1.2.1** The first digit indicates the quadrant in which the incident has occurred, as follows:

**8.1.2.1.1** quadrant NE is indicated by the digit “0”,

**8.1.2.1.2** quadrant NW is indicated by the digit “1”,

**8.1.2.1.3** quadrant SE is indicated by the digit “2”,

**8.1.2.1.4** quadrant SW is indicated by the digit “3”.

**8.1.2.2** The next four figures indicate the latitude in degrees and minutes.

**8.1.2.3** The next five figures indicate the longitude in degrees and minutes.

**8.1.2.4** If “distress coordinates” cannot be included, or if the position information has not been updated for 23½ h, the 10 digits following the “nature of distress” should be automatically transmitted as the digit 9 repeated 10 times.

**8.1.3** Message 3 is the time indication (UTC) when the coordinates were valid consisting of four digits coded on the principles described in Table 2, in pairs starting from the first and second digits.

**8.1.3.1** The first two digits indicate the time in hours.

**8.1.3.2** The third and fourth digits indicate the part of the hours in minutes.

**8.1.3.3** If the time cannot be included the four time indicating digits should be transmitted automatically as “8 8 8 8”.

**8.1.4** Message 4 is a single character to indicate the type of communication (telephone or FEC teleprinter) which is preferred by the station in distress for subsequent exchange of distress traffic. This character is coded as shown in Table 3 first telecommand.

**8.2** For a distress relay, distress relay acknowledgement, distress acknowledgement (see Tables 4.2, 4.3 and 4.4) the distress information is contained in five messages in the following order:

**8.2.1** Message 0 is the “MMSI” of the vessel in distress.

**8.2.2** Message 1 is the “nature of distress” message, coded as shown in Table 3, i.e.:

**8.2.2.1** fire, explosion;

**8.2.2.2** flooding;

**8.2.2.3** collision;

**8.2.2.4** grounding;

**8.2.2.5** listing, in danger of capsizing;

**8.2.2.6** sinking;

**8.2.2.7** disabled and adrift;

**8.2.2.8** undesignated distress;

**8.2.2.9** abandoning ship;

**8.2.2.10** piracy/armed robbery attack;

**8.2.2.11** man overboard;

**8.2.2.12** emergency position-indicating radiobeacon (EPIRB) emission.

**8.2.3** Message 2 is the “distress coordinates” message, consisting of ten digits indicating the location of the vessel in distress, coded on the principles described in Table 2, in pairs starting from the first and second digits (see Note 1 to § 5.3):

**8.2.3.1** The first digit indicates the quadrant in which the incident has occurred, as follows:

**8.2.3.1.1** quadrant NE is indicated by the digit “0”,

**8.2.3.1.2** quadrant NW is indicated by the digit “1”,

**8.2.3.1.3** quadrant SE is indicated by the digit “2”,

**8.2.3.1.4** quadrant SW is indicated by the digit “3”.

**8.2.3.2** The next four figures indicate the latitude in degrees and minutes.

**8.2.3.3** The next five figures indicate the longitude in degrees and minutes.

**8.2.3.4** If “distress coordinates” cannot be included, or if the position information has not been updated for 23½ h, the 10 digits following the “nature of distress” should be automatically transmitted as the digit 9 repeated 10 times.

**8.2.4** Message 3 is the time indication (UTC) when the coordinates were valid consisting of four digits coded on the principles described in Table 2, in pairs starting from the first and second digits.

**8.2.4.1** The first two digits indicate the time in hours.

**8.2.4.2** The third and fourth digits indicate the part of the hours in minutes.

**8.2.4.3** If the time cannot be included the four time indicating digits should be transmitted automatically as “8 8 8 8”.

**8.2.5** Message 4 is a single character to indicate the type of communication (telephone or FEC teleprinter) which is preferred by the station in distress for subsequent exchange of distress traffic. This character is coded as shown in Table 3 first telecommand.

**8.3** For other types of calls (see Table 4.5 through 4.10.2 and Figs. 2 and 3) messages are included in the following order:

**8.3.1** Message 1 is the “telecommand” information and consists of 2 characters (first and second telecommand) coded as shown in Table 3;

**8.3.1.1** if no information additional to that conveyed by the first telecommand character is required, then the second telecommand signal should be symbol No. 126 (no information) (see Table 3);

**8.3.1.2** if no telecommand information is used, symbol No. 126 is transmitted twice.

**8.3.1.3** If the telecommand 1 is “F3E/G3E duplex TP” (symbol 101) in a request, which can be complied with, the telecommand 1 “F3E/G3E all modes TP” (symbol 100) should be used in the acknowledgement.

**8.3.2** Message 2 may contain two “channel or frequency message” elements, each of which always consists of three characters, “character 1”, “character 2” and “character 3”, indicating the proposed working frequency (in the F1B/J2B mode the assigned frequency should be used) in multiples of 100 Hz or the channel number (coded in accordance with Table 5) or the ship’s position. The first frequency element (the RX field) in the call indicates the called station receive frequency and the second frequency element (the TX field) indicates the called station transmit frequency. In acknowledgements the RX and TX fields indicate the receive and transmit frequency of the acknowledging station respectively (see also Fig. 2 and Note 1).

NOTE 1 – If only one channel or frequency message element is used, this indicates the called station receive channel or frequency or a two-frequency (paired) channel. A second channel or frequency message element may be used to designate the called station transmit channel or frequency. If the calling station indicates only the called station receive frequency (for broadcast mode transmissions) then the symbol No. 126 repeated three times should be transmitted instead of the called station transmit channel or frequency message element. If no “channel or frequency message” elements are used, the symbol No. 126 is transmitted six times. For calls using the semi-automatic/automatic VHF service (see Table 4.10.1) then only one “channel or frequency message” element is transmitted which indicates the paired channel number. In the absence of this element the symbol No. 126 should be transmitted three times.

### **8.3.2.1 Frequency information**

The frequency (in the F1B/J2B mode the assigned frequency should be used) in multiples of 100 Hz may only be indicated as such when the frequency is below 30 MHz. The three characters provide for the required six decimal digits. Character 1 represents the units (U) and tens (T) of 100 Hz, character 2 the hundreds (H) and thousands (M) and character 3 the tens of thousands (TM) and hundreds of thousands (HM) of 100 Hz. For MF/HF DSC, use frequency selection mode, vice channel selection mode, to ensure international interoperability.

### **8.3.2.2 Channel information**

#### **8.3.2.2.1 HF and MF channels**

If the HM digit is 3, this indicates that the number represented by the digits TM, M, H, T and U is the HF/MF working channel number (either single frequency or two frequency channels). This mode should only be used for decoding received calls, to ensure interoperability with older equipment.

### 8.3.2.2.2 VHF channels

If the HM digit is 9, this indicates that the number represented by the values of the digits M, H, T and U is the VHF working channel number. If the M digit is 1, this indicates that the ship stations transmitting frequency is being used as a simplex channel frequency for both ship and coast stations. If the M digit is 2, this indicates that the coast stations transmitting frequency is being used as a simplex channel frequency for both ship and coast stations.

### 8.3.2.3 Ship's position information

**8.3.2.3.1** For MF/HF calls, Message 2 may contain the ship's position, consisting of the digit 5 repeated two times and ten digits (five characters) indicating this position, coded in accordance with § 8.1.2 to § 8.1.2.3 (see Table 6).

**8.3.2.3.2** For position requests message 2 consists of 6 no information symbols (symbol No. 126).

**8.3.2.3.3** In acknowledgements to a call requesting ship's position (see Fig. 3d)) message 2 consists of twelve digits (six symbols), the first of which should be coded in accordance with § 8.1.2 to § 8.1.2.3 followed by one symbol No. 126.

Message 3 follows message 2 in this case and contains the time (UTC) when the coordinates were valid, coded as indicated in § 8.1.3 to § 8.1.3.3.

**8.3.3** Message 3 follows message 2 when using the DSC system for calls initiated by ship stations requiring a semi-automatic or automatic connection (see Table 4.10.1 and 4.10.2) and contains the public switched network number (e.g. telephone number). In this case the format specifier used is symbol No. 123.

**8.3.3.1** This number is coded by up to nine symbols in a manner similar to that shown in Table 2, except that the first character transmitted should be either symbol No. 105 or No. 106 to indicate whether the network number contains an odd or even number of significant digits. As an example, the number 0012345 would be coded as symbol numbers 105 00 01 23 45 whereas the number 00123456 should be coded as symbol numbers 106 00 12 34 56.

**8.4** For "distress relay" including shore-to-ship alerts, "distress relay acknowledgement" and "distress acknowledgement" calls, the message formats are indicated in Tables 4.3, 4.4 and 4.2 respectively.

**8.4.1** When sending a distress alert on behalf of another ship which is unable to send its own alert, and where the identity of the station in distress is unknown, the distress relay call should contain the symbol No. 126 transmitted five times for the "identification of the station in distress".

## 8.5 Test calls

Test calls on the distress and safety frequencies for MF and HF and VHF channel 70 may be conducted using the test call sequence in Table 4.7.

## 9 End of sequence

The "end of sequence" (EOS) character is transmitted three times in the DX position and once in the RX position (see Fig. 1b)). It is one of the three unique characters corresponding to symbol Nos. 117, 122 and 127 as follows:

**9.1** symbol No. 117 if the call requires acknowledgement (Acknowledge RQ), used for individual and automatic/semiautomatic calls only;

**9.2** symbol No. 122 if the sequence is an answer to a call that requires acknowledgement (Acknowledge BQ), used for individual and automatic/semiautomatic calls and all distress relay acknowledgements;

**9.3** symbol No. 127 for all other calls.

## **10 Error-check character**

**10.1** The error-check character (ECC) is the final character transmitted and it serves to check the entire sequence for the presence of errors which are undetected by the ten-unit error-detecting code and the time diversity employed.

**10.2** The seven information bits of the ECC shall be equal to the least significant bit of the modulo-2 sums of the corresponding bits of all information characters (i.e. even vertical parity). The format specifier and the EOS characters are considered to be information characters. The phasing characters and the retransmission (RX) characters shall not be considered to be information characters. Only one format specifier character and one EOS character should be used in constructing the ECC. The ECC shall also be sent in the DX and RX positions.

**10.3** Automatic acknowledgement transmissions should not start unless the ECC is received and decoded correctly. A received ECC which does not match that calculated from the received information characters may be ignored if this was due to an error detected in the ten-unit error-detecting code of the information characters which was correctable by use of the time diversity code.

**10.4** The receiver decoder should provide maximum utilization of the received signal, including use of the error-check character.

## **11 Distress alert attempt**

**11.1** Distress alerts may be transmitted as a single frequency or a multi-frequency call attempt preceded by a dot pattern. MF/HF equipment should be capable of using both single and multi-frequency call attempts. Where a distress alert attempt contains more than one consecutive distress alert on the same frequency (see Recommendation ITU-R M.541, Annex 1, § 3.1.3), these consecutive alerts should be transmitted with no gap between the end of one call and the start of the dot pattern of the following call to enable bit synchronization to be maintained (see Fig. 1c)). Multi-frequency call attempts should always include at least the MF and HF 8 MHz band DSC distress and safety frequencies.

**11.2** A distress alert should be activated only by means of a dedicated distress button which should be clearly identified and be protected against inadvertent operation with a spring loaded lid or cover. The initiation of a distress alert should at least require two independent actions.

**11.3** Calls with format specifier “distress” or category “distress”, “urgency” and “safety” should be initiated manually only. This applies also for ships equipped for automatic DSC operation. For automatic repetition of distress alerts see Recommendation ITU-R M.541, Annex 1, § 3.1.3 and 3.3.5.

**11.4** Immediately following a distress alert a DSC expansion message giving enhanced position resolution according to Recommendation ITU-R M.821 should be transmitted in the following manner.

**11.4.1** For a single frequency distress alert attempt the expansion message should be transmitted immediately after the last of five consecutive distress alerts.



**11.4.2** For a multi-frequency distress alert attempt the expansion message should be transmitted immediately after each distress alert.

## **12 Shipborne human machine interface (HMI)**

### **12.1 Shipborne aural alarm**

Shipborne alarms should start softly and increase in volume if not silenced by the operator. This will give the operator the opportunity to acknowledge the alarm without interrupting the ship's current communications. It should be possible for the operator to disable all audible alarms except those of distress, priority and urgency.

Distress and urgency calls should have a distinctive two tone alarm. The alarm should consist of two substantially sinusoidal audio-frequency tones, transmitted alternately. One tone should have a frequency of 2 200 Hz and the other a frequency of 1 300 Hz. The duration of each tone should be 250 ms.

Distress calls and urgency calls should activate an alarm. For HF and MF distress calls, the alarm should activate only when a distress alert, distress acknowledgement, or a distress relay is received and the distress position is within 500 nm (926 km) of the receiving vessel's position, or if the distress position is in the polar areas (latitude greater than 70° N or 70° S). The alarm should also activate when the call is received and the distance between the vessel in distress and the receiving vessel cannot be determined.

NOTE 1 – Disabling of aural alarm does not affect handling of call.

For geographic area calls, the alarm appropriate to the category should activate when the receiving station's position is within the area specified by the call or the receiving station's position is not known. The alarm should not be activated where duplicate distress relay calls are received within one hour. A duplicate distress relay call is one having format specifier all ships or geographic area that contains identical message information, as defined in § 8.1 and an identical distress MMSI.

### **12.2 Inactivity timer**

During normal operation, the equipment should include an inactivity timer to return the DSC system display to default or standby mode if the operator is in a menu where DSC call reception is disabled and does not make any selections or changes for 10 min.

### **12.3 Display**

The information on the display should be visible in all shipboard lighting conditions. It should have the means to display, in plain language, the information contained in the received call. For Class A/B DSC equipment, the display should have a minimum of 160 characters in two or more lines.

### **12.4 MMSI**

DSC equipment should not transmit any DSC call until own ship's MMSI allocated to the ship by the relevant administration has been configured and stored in the DSC equipment. Once stored, it should not be possible for the user to change the MMSI without advice from the manufacturer.

The DSC equipment should display own ship's MMSI on start-up unless the MMSI has not been configured. If the MMSI has not been configured, the equipment will display a warning that the unit will not transmit any DSC calls until own ship's MMSI is entered. The equipment should stay in this state until the operator confirms he has read the display and input own ship's MMSI.

The MMSI should be readily displayed on the HMI when the DSC equipment is on.

### **12.5 Disabling of DSC automatic channel switching function on VHF**

Automatic switching to a subsequent communications channel on receipt of a DSC call might in some cases disrupt important ongoing communications. Where such capability exists, a means for disabling that function should therefore be provided for all calls other than individual station calls of category distress or urgency. The DSC equipment should provide visual indication that the automatic switching function is disabled.

### **12.6 Data interface**

DSC equipment should be provided with facilities for exchange of data from shipborne navigational equipment or systems, or other shipborne equipment as necessary in accordance with IEC 61162 for purposes including automatic position updating.

### **12.7 Position updating**

DSC equipment should accept valid IEC 61162 position information including the time at which the position was determined, from an external source utilizing the data interface described in § 12.6, for automatic update of own ship's DSC position.

The DSC equipment may also be provided with an internal electronic position fixing device. In which case, the DSC equipment should automatically switch to the internal source if the external IEC 61162 position information is not valid or not available.

If the automatic position update is not available, a displayed and audible reminder to manually update the position should occur before the position information is 4 h old. The displayed reminder should remain until position updating has been carried out. Any position information not updated for more than 23½ h should automatically be erased.

Own ship's DSC position information and the source of that information (external, internal, or manually entered) should be displayed on the DSC equipment.

### **12.8 Geographic area entry**

DSC equipment should be provided with means for transforming a geographical area specified by the user as a centre point and a range to the corresponding Mercator area call format specified in § 5.3. The centre point should default to the ship's position information and the range should default to 500 nm (926 km). The transformation of the entered range and centre-point should result in the minimum rectangular area that encompasses the entered data.

### **12.9 Medical transport and neutral ships and aircraft**

The capability of using second telecommands "Ships and aircraft of States not parties to an armed conflict" and "Medical Transports" should not be available by default but only after changing relevant parameters in the setup menu.



FIGURE 2  
Examples of a calling sequence and reply sequences for typical individual calls

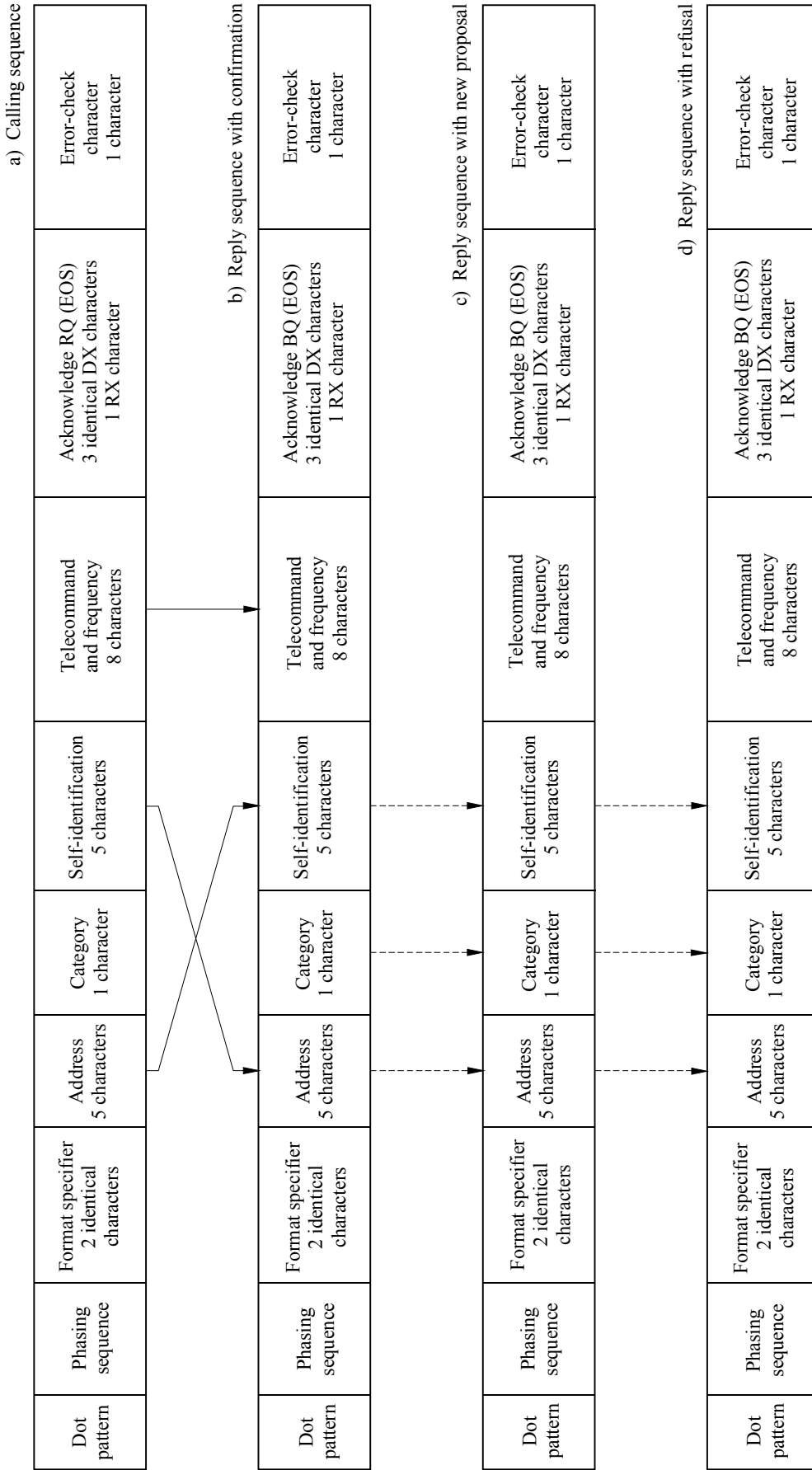
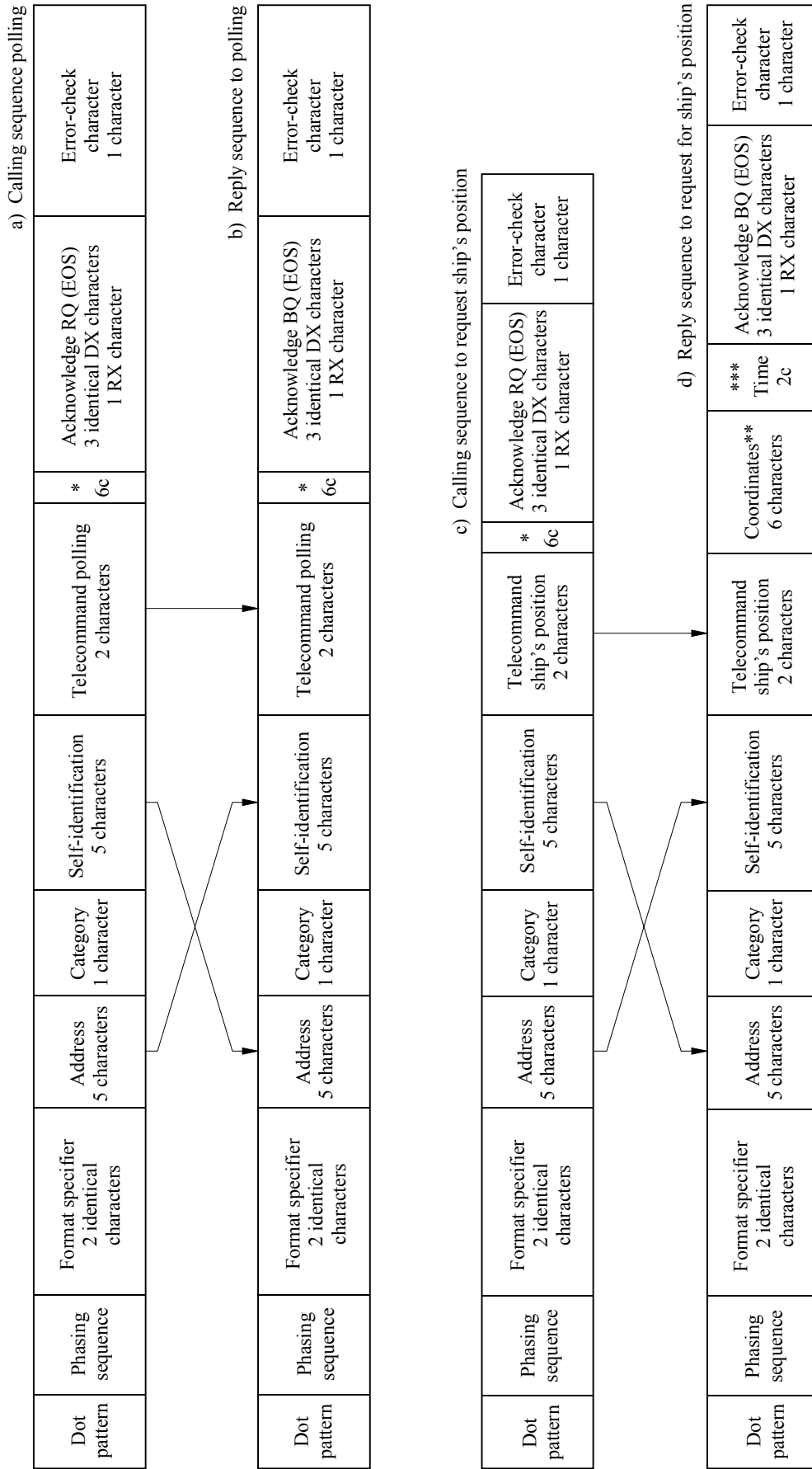

FIGURE 3

Calling sequences and reply sequences for polling and ship's position



\* The symbol No. 126 repeated six times should be included (see § 8.3.2, Note 1).

\*\* See § 8.3.2.3.3 (6 characters).

\*\*\* See § 8.3.2.3.2 (2 characters).

FIGURE 4  
Example of operational flow chart

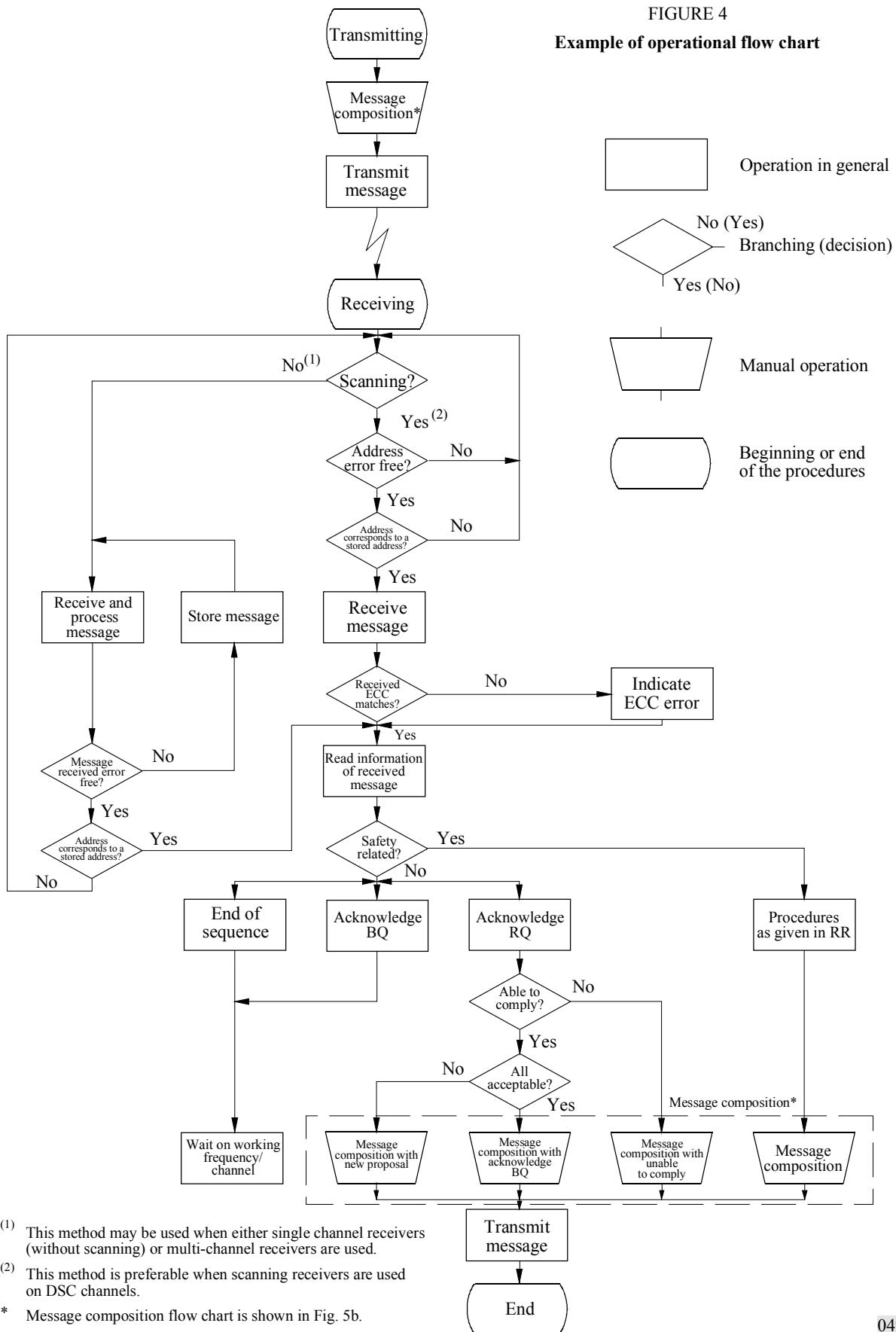

(1) This method may be used when either single channel receivers (without scanning) or multi-channel receivers are used.

(2) This method is preferable when scanning receivers are used on DSC channels.

\* Message composition flow chart is shown in Fig. 5b.

Note – This chart is informative only.

FIGURE 5

Example of message composition flow chart

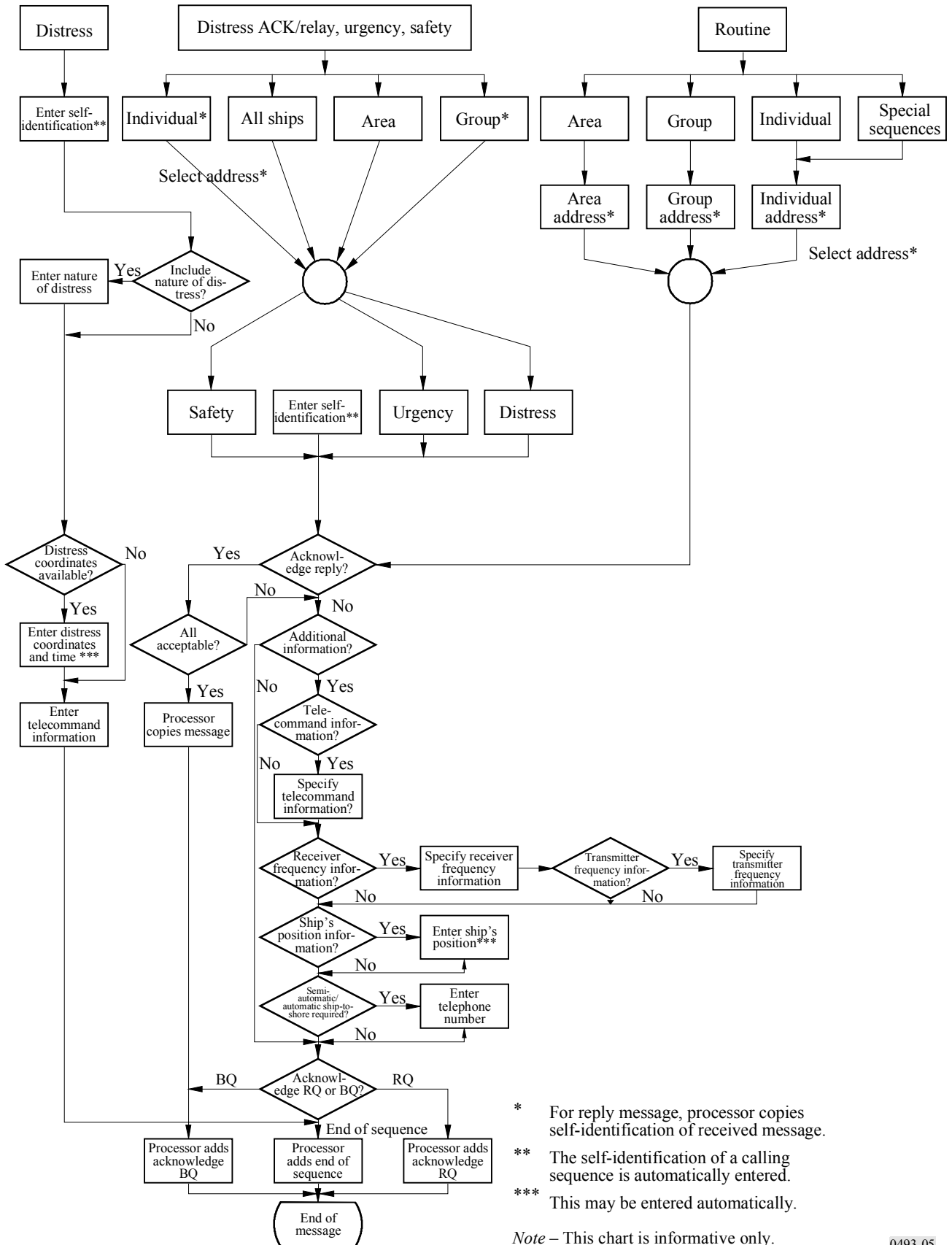
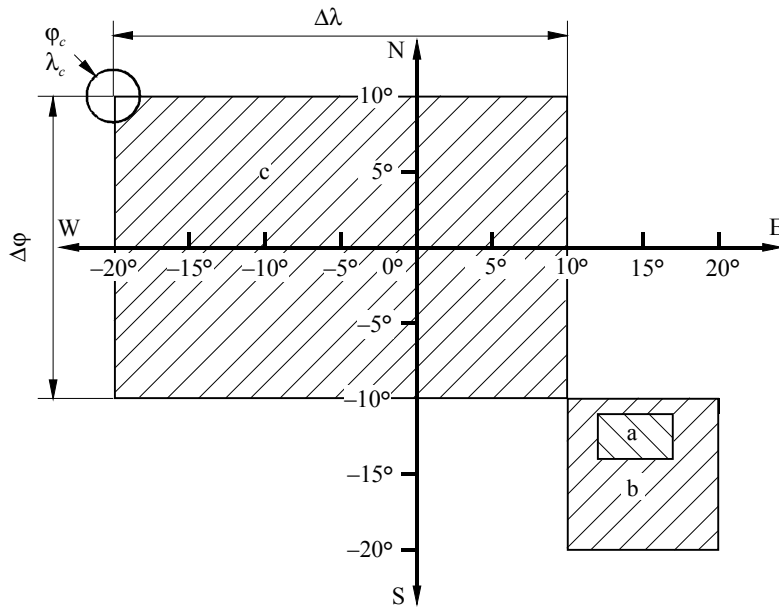

FIGURE 6  
Geographic coordinates



a)  $\phi_a = -11^\circ$  (South)     $\lambda_a = 12^\circ$  (East)     $\Delta\phi = 3^\circ$      $\Delta\lambda = 5^\circ$

Format specifier	2	1	1	0	1	2	0	3	0	5	Category
	Sector		$\phi_a$		$\lambda_a$		$\Delta\phi$		$\Delta\lambda$		

b)  $\phi_b = -10^\circ$  (South)     $\lambda_b = 10^\circ$  (East)     $\Delta\phi = 10^\circ$      $\Delta\lambda = 10^\circ$

Format specifier	2	1	0	0	1	0	1	0	1	0	Category
------------------	---	---	---	---	---	---	---	---	---	---	----------

c)  $\phi_c = 10^\circ$  (North)     $\lambda_c = -20^\circ$  (West)     $\Delta\phi = 20^\circ$      $\Delta\lambda = 30^\circ$

Format specifier	1	1	0	0	2	0	2	0	3	0	Category
------------------	---	---	---	---	---	---	---	---	---	---	----------



**Legend for Tables 4.1 to 4.10.2**

<b>Symbol/expression</b>	<b>Meaning</b>
●	Required
■	Required for backward compatibility
Symbols 100-127	Symbols in accordance with Table 3
Area	Coded in accordance with Annex 1, § 5.3
Frequency	Coded in accordance with Annex 1, § 8.2.2
MMSI	Coded in accordance with Annex 1, § 5.2
Pos1	Coded in accordance with Annex 1, § 8.1.2
Pos2	Coded in accordance with Annex 1, § 8.3.2.3.1
Pos3	Coded in accordance with Annex 1, § 8.3.2.3.2
Pos4	Coded in accordance with Annex 1, § 8.3.2.3.3
Pos5	Coded in accordance with Recommendation ITU-R M.821
UTC	Coded in accordance with Annex 1, § 8.1.3
n/a	This field is not included in this call
ECC	Coded in accordance with Annex 1, § 10.2
expa1	Expansion sequence 1
expa2	Expansion sequence 2
expa3	Expansion sequence 3
	Does not apply

NOTE 1 – For Class A and B all functions are identical for VHF and MF. HF does not apply to Class B.

TABLE 4.1  
Distress alerts

Frequency band	Type	Applicable to								Technical format of call sequence								Rec. ITU-R M.821 expansion sequence (9)	
		Ship station Class A/B		Ship station Class D		Ship station Class E		Coast station		Format specifier (2 identical)	Self-ID (5)	Message				EOS (1)	ECC (1)		EOS (2 identical)
		Tx	Rx	Tx	Rx	Tx	Rx	Tx	Rx			1	2	3	4				
												Nature of distress (1)	Distress coordinates (5)	Time (2)	Subsequent communications (1)				
VHF	Distress (RT)	•	•	•	•				•	112	MMSI	100 to 111	Pos1	UTC	100	127	ECC	127	expan1
	Distress (EPIRB)		•		•				•	112	MMSI	112	Pos1	UTC	126	127	ECC	127	expan1
MF/HF	Distress (RT)	•	•			•	•		•	112	MMSI	100 to 111	Pos1	UTC	109	127	ECC	127	expan1
	Distress (FEC)	•	•				•		•	112	MMSI	100 to 111	Pos1	UTC	113	127	ECC	127	expan1

Rec. ITU-R M.821 expansion sequence					
Type	Expansion data specifier (1)	Enhanced position resolution (4)	EOS (1)	ECC (1)	EOS (2 identical)
expan1	100	Pos5	127	ECC	127

TABLE 4.2  
Distress acknowledgements

Frequency band	Type	Applicable to								Technical format of call sequence											Rec. ITU-R M.821 expansion sequence (9)	
		Ship station Class A/B		Ship station Class D		Ship station Class E		Coast station		Format specifier (2 identical)	Category (1)	Self-ID (5) <sup>(1)</sup>	Tele-command (1)	Message					EOS (1)	ECC (1)		EOS (2 identical)
		Tx	Rx	Tx	Rx	Tx	Rx	Tx	Rx					0	1	2	3	4				
														Distress MMSI (5)	Nature of distress (1)	Distress coordinates (5)	Time (2)	Subsequent communications (1)				
VHF	Distress acknowledgement (RT)	●	●	·	●	·	·	●	●	116	112	MMSI	110	MMSI	100 to 111	Pos1	UTC	100	127	ECC	127	expan1
	Distress acknowledgement (EPIRB)	●	●	·	●	·	·	●	●	116	112	MMSI	110	MMSI	112	Pos1	UTC	126	127	ECC	127	expan1
MF	Distress acknowledgement (RT)	●	●	·	·	·	●	●	●	116	112	MMSI	110	MMSI	100 to 111	Pos1	UTC	109	127	ECC	127	expan1
	Distress acknowledgement (FEC)	●	●	·	·	·	●	●	●	116	112	MMSI	110	MMSI	100 to 111	Pos1	UTC	113	127	ECC	127	expan1
HF	Distress acknowledgement (RT)	·	●	·	·	·	●	●	●	116	112	MMSI	110	MMSI	100 to 111	Pos1	UTC	109	127	ECC	127	expan1
	Distress acknowledgement (FEC)	·	●	·	·	·	●	●	●	116	112	MMSI	110	MMSI	100 to 111	Pos1	UTC	113	127	ECC	127	expan1

<sup>(1)</sup> Distress acknowledgments where the transmitting MMSI and ship in distress MMSI are the same, the message should be interpreted as a self Cancel operation. This should be displayed on all receiving stations. The function should be implemented on new equipment. (NOTE 1 – Class D and E equipment should be capable of transmitting a self cancel.)

The message should match the received distress alert information, except for manually generated distress acknowledgements by coast stations.

Rec. ITU-R M.821 expansion sequence					
Type	Expansion data specifier (1)	Enhanced position resolution (4)	EOS (1)	ECC (1)	EOS (2 identical)
expan1	100	Pos5	127	ECC	127

TABLE 4.3  
Distress relays

Frequency band	Type	Applicable to								Technical format of call sequence											Rec. ITU-R M.821 expansion sequence (9)		
		Ship station Class A/B		Ship station Class D		Ship station Class E		Coast station		Format specifier (2 identical)	Address (5)	Category (1)	Self-ID (5)	Tele-command (1)	Message					EOS (1)		ECC (1)	EOS (2 identical)
		Tx	Rx	Tx	Rx	Tx	Rx	Tx	Rx						0	1	2	3	4				
VHF	Individual (RT)	●	●	● <sup>(1)</sup>	·	·	●	●	120	MMSI	112	MMSI	112	MMSI	100 to 111	Pos1	UTC	100	117	ECC	117	expan2	
	Individual (EPIRB)	●	●	·	● <sup>(1)</sup>	·	·	●	●	120	MMSI	112	MMSI	112	MMSI	112	Pos1	UTC	126	117	ECC	117	expan2
	Geographic area (RT)	·	■	·	■ <sup>(1)</sup>	·	·	·	■	102	Zone	112	MMSI	112	MMSI	100 à 111	Pos1	UTC	100	127	ECC	127	expan1
	Geographic area (EPIRB)	·	■	·	■ <sup>(1)</sup>	·	·	·	■	102	Zone	112	MMSI	112	MMSI	112	Pos1	UTC	126	127	ECC	127	expan1
	All ships (RT)	●	●	·	● <sup>(1)</sup>	·	·	●	●	116	n/a	112	MMSI	112	MMSI	100 to 111	Pos1	UTC	100	127	ECC	127	expan1
	All ships (EPIRB)	●	●	·	● <sup>(1)</sup>	·	·	●	●	116	n/a	112	MMSI	112	MMSI	112	Pos1	UTC	126	127	ECC	127	expan1
MF/HF	Individual (RT)	●	●	·	·	·	●	●	●	120	MMSI	112	MMSI	112	MMSI	100 to 111	Pos1	UTC	109	117	ECC	117	expan2
	Individual (FEC)	●	●	·	·	·	●	●	●	120	MMSI	112	MMSI	112	MMSI	100 to 111	Pos1	UTC	113	117	ECC	117	expan2
	Geographic area (RT)	●	●	·	·	·	●	●	●	102	Zone	112	MMSI	112	MMSI	100 to 111	Pos1	UTC	109	127	ECC	127	expan1
	Geographic area (FEC)	●	●	·	·	·	●	●	●	102	Zone	112	MMSI	112	MMSI	100 to 111	Pos1	UTC	113	127	ECC	127	expan1

<sup>(1)</sup> This call is not applicable to hand-held equipment.

TABLE 4.3 (end)

Frequency band	Type	Applicable to								Technical format of call sequence											Rec. ITU-R M.821 expansion sequence (9)		
		Ship station Class A/B		Ship station Class D		Ship station Class E		Coast station		Format specifier (2 identical)	Address (5)	Category (1)	Self-ID (5)	Tele-command (1)	Message					EOS (1)		ECC (1)	EOS (2 identical)
		Tx	Rx	Tx	Rx	Tx	Rx	Tx	Rx						0	1	2	3	4				
															Distress MMSI (5)	Nature of distress (1)	Distress coordinates (5)	Time (2)	Subsequent communications (1)				
MF/HF (End)	All ships (RT)	·	■	·	·	·	■	·	■	116	n/a	112	MMSI	112	MMSI	100 to 111	Pos1	UTC	109	127	ECC	127	expan1
	All ships (FEC)	·	■	·	·	·	■	·	■	116	n/a	112	MMSI	112	MMSI	100 to 111	Pos1	UTC	113	127	ECC	127	expan1
														The message should match the received distress alert information, except for manually generated relays observed or notified by non-DSC means.									

Rec. ITU-R M.821 expansion sequence					
Type	Expansion data specifier (1)	Enhanced position resolution (4)	EOS (1)	ECC (1)	EOS (2 identical)
expan1	100	Pos5	127	ECC	127
expan2	100	Pos5	117	ECC	117

TABLE 4.4

Distress relay acknowledgements

Frequency band	Type	Applicable to								Technical format of call sequence											Rec. ITU-R M.821 expansion sequence (9)		
		Ship station Class A/B		Ship station Class D		Ship station Class E		Coast station		Format specifier (2 identical)	Address (5)	Category (1)	Self-ID (5)	Tele-command (1)	Message					EOS (1)		ECC (1)	EOS (2 identical)
		Tx	Rx	Tx	Rx	Tx	Rx	Tx	Rx						0	1	2	3	4				
															Distress MMSI (5)	Nature of distress (1)	Distress coordinates (5)	Time (2)	Subsequent communications (1)				
VHF	Individual (RT)	●	●	●	● <sup>(1)</sup>	·	·	●	●	120	MMSI	112	MMSI	112	MMSI	100 to 111	Pos1	UTC	100	122	ECC	122	expan3
	Individual (EPIRB)	●	●	·	● <sup>(1)</sup>	·	·	●	●	120	MMSI	112	MMSI	112	MMSI	112	Pos1	UTC	126	122	ECC	122	expan3
	All ships (RT)	·	●	·	● <sup>(1)</sup>	·	·	●	●	116	n/a	112	MMSI	112	MMSI	100 to 111	Pos1	UTC	100	122	ECC	122	expan3
	All ships (EPIRB)	·	●	·	● <sup>(1)</sup>	·	·	●	●	116	n/a	112	MMSI	112	MMSI	112	Pos1	UTC	126	122	ECC	122	expan3
MF/HF	Individual (RT)	●	●	·	·	●	●	●	●	120	MMSI	112	MMSI	112	MMSI	100 to 111	Pos1	UTC	109	122	ECC	122	expan3
	Individual (FEC)	●	●	·	·	·	●	●	●	120	MMSI	112	MMSI	112	MMSI	100 to 111	Pos1	UTC	113	122	ECC	122	expan3
	All ships (RT)	·	■	·	·	·	●	●	●	116	n/a	112	MMSI	112	MMSI	100 to 111	Pos1	UTC	109	122	ECC	122	expan3
	All ships (FEC)	·	■	·	·	·	●	●	●	116	n/a	112	MMSI	112	MMSI	100 to 111	Pos1	UTC	113	122	ECC	122	expan3

<sup>(1)</sup> This call is not applicable to hand-held equipment.

The message should match the received distress relay call information.

· · · · ·

Rec. ITU-R M.821 expansion sequence					
Type	Expansion data specifier (1)	Enhanced position resolution (4)	EOS (1)	ECC (1)	EOS (2 identical)
expan3	100	Pos5	122	ECC	122

TABLE 4.5  
Urgency and safety calls – All ships

Frequency band	Type	Applicable to								Technical format of call sequence								
		Ship station Class A/B		Ship station Class D		Ship station Class E		Coast station		Format specifier (2 identical)	Category (1)	Self-ID (5)	Message		EOS (1)	ECC (1)	EOS (2 identical)	
		Tx	Rx	Tx	Rx	Tx	Rx	Tx	Rx				1					Frequency (6)
													1st tele-command (1)	2nd tele-command (1)				
VHF	All modes RT	●	●	● <sup>(2)</sup>	●	·	·	●	●	116	108 or 110	MMSI	100	126	Frequency	127	ECC	127
	Duplex RT <sup>(1)</sup>	·	■	·	■	·	·	·	■	116	108 or 110	MMSI	101	126	Frequency	127	ECC	127
	Medical transports	●	●	·	·	·	·	·	●	116	110	MMSI	100	111	Frequency	127	ECC	127
	Ships and aircraft (Res. 18)	●	●	·	·	·	·	·	●	116	110	MMSI	100	110	Frequency	127	ECC	127
MF/HF	J3E RT	·	·	·	·	·	·	·	■	116	108 or 110	MMSI	109	126	Frequency	127	ECC	127
	F1B FEC	·	·	·	·	·	·	·	■	116	108 or 110	MMSI	113	126	Frequency	127	ECC	127

<sup>(1)</sup> See § 8.3.1.3.

<sup>(2)</sup> This call is not applicable to hand-held equipment.

TABLE 4.6  
Urgency and safety – Geographic area calls

Frequency band	Type	Applicable to								Technical format of call sequence									
		Ship station Class A/B		Ship station Class D		Ship station Class E		Coast station		Format specifier (2 identical)	Address (5)	Category (1)	Self-ID (5)	Message			EOS (1)	ECC (1)	EOS (2 identical)
		Tx	Rx	Tx	Rx	Tx	Rx	Tx	Rx					1		2			
														1st tele-command (1)	2nd tele-command (1)				
MF/HF	J3E (RT)	●	●	·	·	●	●	●	●	102	Area	108 or 110	MMSI	109	126	Frequency	127	ECC	127
	F1B (FEC)	●	●	·	·	·	·	●	●	102	Area	108 or 110	MMSI	113	126	Frequency	127	ECC	127
	Medical transports	●	●	·	·	·	·	·	●	102	Area	110	MMSI	109 or 113	111	Frequency	127	ECC	127
	Ships and aircraft (Res. 18)	●	●	·	·	·	·	·	●	102	Area	110	MMSI	109 or 113	110	Frequency	127	ECC	127



TABLE 4.7  
 Urgency and safety – Individual calls and their acknowledgements

Frequency band	Type	Applicable to								Technical format of call sequence										
		Ship station Class A/B		Ship station Class D		Ship station Class E		Coast station		Format specifier (2 identical)	Address (5)	Category (1)	Self-ID (5)	Message			EOS (1)	ECC (1)	EOS (2 identical)	
		Tx	Rx	Tx	Rx	Tx	Rx	Tx	Rx					1		2				3
														1st tele-command (1)	2nd tele-command (1)	Frequency or pos number (6)				Time (2)
VHF	All modes RT	●	●	·	●	·	·	●	●	120	MMSI	108 or 110	MMSI	100	126	Frequency	n/a	117	ECC	117
	Duplex RT <sup>(1)</sup>	·	■		·	·	·	·	■	120	MMSI	108 or 110	MMSI	101	126	Frequency	n/a	117	ECC	117
	RT acknowledgement	●	●	●	·	·	·	●	●	120	MMSI	108 or 110	MMSI	100	126	Frequency	n/a	122	ECC	122
	Unable to comply acknowledgement	●	●	●	·	·	·	●	●	120	MMSI	108 or 110	MMSI	104	100 to 109	Frequency	n/a	122	ECC	122
	Position request	●	●	·	·	·	·	●	·	120	MMSI	108	MMSI	121	126	Pos3	n/a	117	ECC	117
	Position acknowledgement	●	●	·	·	·	·	·	●	120	MMSI	108	MMSI	121	126	Pos4	UTC	122	ECC	122
	Test	●	●	●	●	·	·	●	●	120	MMSI	108	MMSI	118	126	126	n/a	117	ECC	117
	Test acknowledgement	●	●	●	●	·	·	●	●	120	MMSI	108	MMSI	118	126	126	n/a	122	ECC	122

TABLE 4.7 (end)

Frequency band	Type	Applicable to								Technical format of call sequence										
		Ship station Class A/B		Ship station Class D		Ship station Class E		Coast station		Format specifier (2 identical)	Address (5)	Category (1)	Self-ID (5)	Message				EOS (1)	ECC (1)	EOS (2 identical)
		1		2		3														
		1st tele-command (1)	2nd tele-command (1)	Frequency or pos number (6)	Time (2)															
Tx	Rx	Tx	Rx	Tx	Rx	Tx	Rx													
MF/HF	J3E RT	●	●	·	·	·	●	●	●	120	MMSI	108 or 110	MMSI	109	126	Frequency	n/a	117	ECC	117
	J3E RT with pos number	●	·	·	·	·	·	·	●	120	MMSI	108 or 110	MMSI	109	126	Pos2	n/a	117	ECC	117
	J3E RT acknowledgement	●	●	·	·	●	·	●	●	120	MMSI	108 or 110	MMSI	109	126	Frequency	n/a	122	ECC	122
	F1B FEC or ARQ	●	●	·	·	·	·	●	●	120	MMSI	108 or 110	MMSI	113 or 115	126	Frequency	n/a	117	ECC	117
	F1B FEC or ARQ with pos number	●	·	·	·	·	·	·	●	120	MMSI	108 or 110	MMSI	113 or 115	126	Pos2	n/a	117	ECC	117
	F1B FEC or ARQ acknowledgement	●	●	·	·	·	·	●	●	120	MMSI	108 or 110	MMSI	113 or 115	126	Frequency	n/a	122	ECC	122
	Unable to comply acknowledgement	●	●	·	·	●	·	●	●	120	MMSI	108 or 110	MMSI	104	100 to 109	Frequency	n/a	122	ECC	122
	Position request	●	●	·	·	·	·	●	·	120	MMSI	108	MMSI	121	126	Pos3	n/a	117	ECC	117
	Position acknowledgement	●	●	·	·	·	·	·	●	120	MMSI	108	MMSI	121	126	Pos4	UTC	122	ECC	122
	Test	●	●	·	·	●	●	●	●	120	MMSI	108	MMSI	118	126	126	n/a	117	ECC	117
Test acknowledgement	●	●	·	·	●	●	●	●	120	MMSI	108	MMSI	118	126	126	n/a	122	ECC	122	

(1) See § 8.3.1.3.

TABLE 4.8  
Routine group calls

Frequency band	Type	Applicable to								Technical format of call sequence									
		Ship station Class A/B		Ship station Class D		Ship station Class E		Coast station		Format specifier (2 identical)	Address (5)	Category (1)	Self-ID (5)	Message			EOS (1)	ECC (1)	EOS (2 identical)
		Tx	Rx	Tx	Rx	Tx	Rx	Tx	Rx					1		2			
														1st tele-command (1)	2nd tele-command (1)	Frequency (6)			
VHF	All mode RT	●	●	●	●	·	·	●	●	114	MMSI	100	MMSI	100	126	Frequency	127	ECC	127
	Duplex RT <sup>(1)</sup>		■	·	·	·	·		■	114	MMSI	100	MMSI	101	126	Frequency	127	ECC	127
MF/HF	J3E RT	●	●	■	■	●	●	●	●	114	MMSI	100	MMSI	109	126	Frequency	127	ECC	127
	F1B FEC	●	●	·	·	·	·	●	●	114	MMSI	100	MMSI	113	126	Frequency	127	ECC	127

<sup>(1)</sup> See § 8.3.1.3.

TABLE 4.9  
Routine individual calls and their acknowledgements

Frequency band	Type	Applicable to								Technical format of call sequence									
		Ship station Class A/B		Ship station Class D		Ship station Class E		Coast station		Format specifier (2 identical)	Address (5)	Category (1)	Self-ID (5)	Message			EOS (1)	ECC (1)	EOS (2 identical)
		Tx	Rx	Tx	Rx	Tx	Rx	Tx	Rx					1		2			
														1st tele-command (1)	2nd tele-command (1)				
VHF	All mode RT	●	●	●	●	·	·	●	●	120	MMSI	100	MMSI	100	126	Frequency	117	ECC	117
	Duplex RT <sup>(1)</sup>		■			·	·		■	120	MMSI	100	MMSI	101	126	Frequency	117	ECC	117
	RT acknowledgement	●	●	●	●	·	·	●	●	120	MMSI	100	MMSI	100	126	Frequency	122	ECC	122
	Data	●	●	·	·	·	·	●	●	120	MMSI	100	MMSI	106	126	Frequency	117	ECC	117
	Data acknowledgement	●	●	·	·	·	·	●	●	120	MMSI	100	MMSI	106	126	Frequency	122	ECC	122
	Unable to comply acknowledgement	●	●			·	·	●	●	120	MMSI	100	MMSI	104	100 to 109	Frequency	122	ECC	122
	Polling	·	●	·	·	·	·	●	■	120	MMSI	100	MMSI	103	126	126	117	ECC	117
	Polling acknowledgement	●	·	·	·	·	·	■	●	120	MMSI	100	MMSI	103	126	126	122	ECC	122

TABLE 4.9 (end)

Frequency band	Type	Applicable to								Technical format of call sequence									
		Ship station Class A/B		Ship station Class D		Ship station Class E		Coast station		Format specifier (2 identical)	Address (5)	Category (1)	Self-ID (5)	Message			EOS (1)	ECC (1)	EOS (2 identical)
		Tx	Rx	Tx	Rx	Tx	Rx	Tx	Rx					1		Frequency or pos number (6)			
														1st tele-command (1)	2nd tele-command (1)				
MF/HF	J3E RT	●	●	·	·	●	●	●	●	120	MMSI	100	MMSI	109	126	Frequency	117	ECC	117
	J3E RT with pos number	●	·	·	·	●	·	·	●	120	MMSI	100	MMSI	109	126	Pos2	117	ECC	117
	J3E RT acknowledgement	●	●	·	·	●	●	●	●	120	MMSI	100	MMSI	109	126	Frequency	122	ECC	122
	F1B FEC, ARQ or data	●	●	·	·	·	·	●	●	120	MMSI	100	MMSI	113, 115, 106	126	Frequency	117	ECC	117
	FEC, ARQ or data with pos number	●	·	·	·	·	·	·	●	120	MMSI	100	MMSI	113, 115, 106	126	Pos2	117	ECC	117
	F1B FEC, ARQ or data acknowledgement	●	●	·	·	·	·	●	●	120	MMSI	100	MMSI	113, 115, 106	126	Frequency	122	ECC	122
	Unable to comply acknowledgement	●	●			·	·	●	●	120	MMSI	100	MMSI	104	100 à 109	Frequency	122	ECC	122
	Polling	·	●	·	·	·	·	●	■	120	MMSI	100	MMSI	103	126	126	117	ECC	117
	Polling acknowledgement	●	·	·	·	·	·	■	●	120	MMSI	100	MMSI	103	126	126	122	ECC	122

<sup>(1)</sup> See § 8.3.1.3.

TABLE 4.10.1  
Semi/auto VHF (optional)

Type	Applicable to								Technical format of call sequence										
	Ship station Class A/B		Ship station Class D		Ship station Class E		Coast station		Format specifier (2 identical)	Address (5)	Category (1)	Self-ID (5)	Message				EOS (1)	ECC (1)	EOS (2 identical)
	1		2		3														
	1st tele-command (1)	2nd tele-command (1)	Frequency (3)	Number (2-9)															
Tx	Rx	Tx	Rx	Tx	Rx	Tx	Rx												
Request	●	●	● <sup>(2)</sup>	● <sup>(2)</sup>	.	.	●	●	123	MMSI	100	MMSI	100, 101, 106	126	Frequency	Number	117	ECC	117
Able to comply acknowledgement	●	●	● <sup>(2)</sup>	● <sup>(2)</sup>	.	.	●	●	123	MMSI	100	MMSI	100, 101, 106	126	Frequency	Number	122	ECC	122
Start of call (on working channel)	●	.	● <sup>(2)</sup>	.	.	.	.	●	123	MMSI	100	MMSI	100, 101, 106	126	Frequency	Number	127	ECC	127
Unable to comply acknowledgement	●	●	● <sup>(2)</sup>	● <sup>(2)</sup>	.	.	●	●	123	MMSI	100	MMSI	104	100-109	Frequency	Number	122	ECC	122
End of call request (on working channel)	●	.	● <sup>(2)</sup>	.	.	.	.	●	123	MMSI	100	MMSI	105	126	Frequency	Number	117	ECC	117
End of call acknowledgement (on working channel) <sup>(1)</sup>	.	●	.	● <sup>(2)</sup>	.	.	●	.	123	MMSI	100	MMSI	105	126	Duration	Number	122	ECC	122

<sup>(1)</sup> Upon call completion the coast station may send the end of call acknowledgement without a request from the ship station. The EOS symbol being 127.

<sup>(2)</sup> This call is not applicable to hand-held equipment.

NOTE 1 – See Recommendation ITU-R M.689.

NOTE 2 – For Class D symbol 123 does not need to be displayed.

TABLE 4.10.2  
Semi/auto MF/HF (optional)

Type	Applicable to								Technical format of call sequence										
	Ship station Class A/B		Ship station Class D		Ship station Class E		Coast station		Format specifier (2 identical)	Address (5)	Category (1)	Self-ID (5)	Message			EOS (1)	ECC (1)	EOS (2 identical)	
													1		2				3
	Tx	Rx	Tx	Rx	Tx	Rx	Tx	Rx					1st tele command (1)	2nd tele-command (1)	Frequency or pos number (6)				Number (2-9)
J3E RT/F1B FEC/ARQ	.	.	.	.	.	.	.	.											
Request coast station	.	●	.	.	.	●	●	.	123	MMSI	100	MMSI	109, 113, 115	126	Frequency	Number	117	ECC	117
Request ship station	●	.	.	.	●	.	.	●	123	MMSI	100	MMSI	109, 113, 115	126	126 or Pos2	Number	117	ECC	117
Able to comply acknowledgement	●	●	.	.	●	●	●	●	123	MMSI	100	MMSI	109, 113, 115	126	Frequency	Number	122	ECC	122
Signal strength test by ship (on working channel) <sup>(1)</sup>	●	.	.	.	●	.	.	●	123	MMSI	100	MMSI	109, 113, 115	126	Frequency	Number	117	ECC	117
Coast station acknowledgement with new working frequency <sup>(1)</sup>	.	●	.	.	.	●	●	.	123	MMSI	100	MMSI	109, 113, 115	126	New frequency	Number	122	ECC	122
Call start: Coast station acknowledgement with same working frequency <sup>(1)</sup>	.	●	.	.	.	●	●	.	123	MMSI	100	MMSI	109, 113, 115	126	Same frequency	Number	122	ECC	122
Unable to comply	●	●	.	.	●	●	●	●	123	MMSI	100	MMSI	104	100 a 109	Frequency	Number	122	ECC	122
End of call request (on working channel)	●	.	.	.	●	.	.	●	123	MMSI	100	MMSI	105	126	Frequency	Number	117	ECC	117
End of call acknowledgement (on working channel) <sup>(2)</sup>	.	●	.	.	.	●	●	.	123	MMSI	100	MMSI	105	126	Duration	Number	122	ECC	122

<sup>(1)</sup> This call involves signal strength testing. The ship requests call by sending the coast station its position. Once the ship or coast station is able to comply the ship station sends test DSCs on the working frequency. If the coast station acknowledges with a new working frequency, the ship station sends a test DSC on the new frequency. When the coast station acknowledges with an unchanged frequency, the subsequent communication may begin.

<sup>(2)</sup> Upon call completion the coast station may send the end of call acknowledgement without a request from the ship station. The EOS symbol being 127.

NOTE 1 – See Recommendation ITU-R M.1082.

NOTE 2 – For Class E symbol 123 does not need to be displayed.

TABLE 5

## Frequency or channel information

Frequency	0 1 2	X X X	X X X	X X X	X X X	X X X	The frequency in multiples of 100 Hz as indicated by the figures for the digits HM, TM, M, H, T, U. This should be used for MF, HF equipment.
Channels	3	X	X	X	X	X	The HF/MF working channel number indicated by the values of the digits TM, M, H, T and U. This should be used for backward compatibility in receive only mode.
	8	X	X	X	X	X	Only used for Recommendation ITU-R M.586 equipment.
	9	0	X <sup>(1)</sup>	X	X	X	The VHF working channel number indicated by the values of the digits M, H, T and U.
	HM	TM	M	H	T	U	
	Character 3	Character 2		Character 1 <sup>(2)</sup>			

- (1) If the M digit is 1 this indicates that the ship stations transmitting frequency is being used as a simplex channel frequency for both ship and coast stations. If the M digit is 2 this indicates that the coast stations transmitting frequency is being used as a simplex channel frequency for both ship and coast stations. If the M digit is 0, this indicates the frequency being used is in accordance with RR Appendix 18 for both single and two frequency channels.
- (2) Character 1 is the last character transmitted.

TABLE 6

## Position information (Annex 1, § 8.3.2.3)

	Quadrant digit NE = 0 NO = 1 SE = 2 SO = 3	Latitude				Longitude				
		Tens of degrees	Units of degrees	Tens of minutes	Units of minutes	Hundre ds of degrees	Tens of degrees	Units of degrees	Tens of minutes	Units of minutes
55	X	X	X	X	X	X	X	X	X	X
Character 6	Character 5		Character 4		Character 3		Character 2		Character 5 <sup>(1)</sup>	

- (1) Character 1 is the last character transmitted.



## Annex 2

### Equipment classes

#### 1 Equipment classes only apply to shipborne equipment

Class A equipment, which includes all the facilities defined in Annex 1, will comply with the IMO GMDSS carriage requirements for MF/HF installations and/or VHF installations.

Class B equipment providing minimum facilities for equipment on ships not required to use Class A equipment and complying with the minimum IMO GMDSS carriage requirements for MF and/or VHF installations.

Class D equipment is intended to provide minimum facilities for VHF DSC distress, urgency and safety as well as routing calling and reception, not necessarily in full accordance with IMO GMDSS carriage requirements for VHF installations.

Class E equipment is intended to provide minimum facilities for MF and/or HF DSC distress, urgency and safety as well as routine calling and reception, not necessarily in full accordance with IMO GMDSS carriage requirements for MF/HF installations.

Class A and Class B equipment may support the optional semi-automatic/automatic service in accordance with Recommendations ITU-R M.689, ITU-R M.1082 and Tables 4.10.1 and 4.10.2 and are encouraged to do so.

Class D and Class E equipment may also support the optional semi-automatic/automatic service.

NOTE 1 – Class C, F and G equipment as defined in earlier versions of this Recommendation (e.g., Recommendations ITU-R M.493-5 (Geneva, 1992) and ITU-R M.493-7 (Geneva, 1995)) did not provide vital minimum DSC functions (transmitting and receiving distress alerts) and have therefore been withdrawn.

#### 2 Class requirements for B, D and E are given in § 3, 4 and 5 (See Tables 4.1 to 4.10.2 for technical requirements)

#### 3 Class B (MF and/or VHF only)

##### 3.1 Transmit capabilities

3.1.1 Format specifier:

- Distress
- All ships
- Geographic area
- Individual station
- Semi-automatic/automatic service
- Ships having common interest (group).

3.1.2 The numerical identification of the called station (address).

3.1.3 Category:

- Distress
- Urgency
- Safety
- Routine.

3.1.4 Self-identification (automatically inserted).

### 3.1.5 Messages

#### 3.1.5.1 For distress alerts:

Message 1: Nature of distress, defaulting to undesignated distress

Message 2: Distress coordinates

Message 3: Time for last position update

Message 4: Type of subsequent communication:

MF: J3E

VHF: F3E/G3E simplex.

#### 3.1.5.2 For distress relay calls:

First telecommand: Distress relay

Identification of the ship: As defined in Annex 1

Messages 1 to 4: As § 3.1.5.1.

#### 3.1.5.3 For distress acknowledgement calls:

First telecommand: Distress acknowledgement

Identification of the ship: As defined in Annex 1

Messages 1 to 4: As § 3.1.5.1.

#### 3.1.5.4 For all other calls:

First telecommand: Unable to comply.

MF: For individual station calls, J3E or “test” (see Annex 1 § 8.4); for calls using the semi-automatic/automatic MF-services, J3E or “end of call”.

VHF: For individual station calls, F3E/G3E or “polling” (see Annex 1 § 8.4); for calls using the semi-automatic/automatic VHF-services F3E/G3E or “end of call”.

Second telecommand: No information.

Frequency/channel or ship’s position: As defined in Annex 1.

Selection information (semi-automatic/automatic service): Telephone number of public telephone subscriber.

#### 3.1.6 End of sequence character: As defined in Annex 1.

### 3.2 Receive capabilities

**3.2.1** Receive and be capable of displaying all the information in calls listed in § 3.1 plus all distress relay calls having the format specifier “geographical area calls”, all distress acknowledgement calls and all “unable to comply” calls.

**3.2.2** Audible alarm upon reception of any DSC call.

## 4 Class D (VHF only)<sup>1</sup>

### 4.1 Transmit capabilities

4.1.1 Format specifier: Distress  
All ships  
Individual station  
Ships having common interest (group).

4.1.2 The numerical identification of the called station (address).

4.1.3 Category: Distress  
Urgency  
Safety  
Routine.

4.1.4 Self-identification (automatically inserted).

### 4.1.5 Messages

4.1.5.1 For distress calls:

Message 1: Nature of distress, defaulting to undesignated distress

Message 2: Distress coordinates

Message 3: Time for last position update

Message 4: Type of subsequent communication: F3E/G3E simplex.

4.1.5.2 For all other calls:

First telecommand: F3E/G3E simplex  
Unable to comply  
Polling.

Second telecommand: No information.

Frequency/channel information: VHF working channel, defaulting to channel 16 for urgency and safety calls and a recognized intership channel (RR Appendix 18) for all other calls.

4.1.6 End of sequence character: As defined in Annex 1.

### 4.2 Receive capabilities

Receive and be capable of displaying all the information in calls listed in § 4.1 plus all distress relay calls except those having the format specifier “geographical area calls”, all distress acknowledgement calls and all “unable to comply” calls.

---

<sup>1</sup> Requirements for sub-category hand-held equipment are specified in Annex 1 Tables 4.1 to 4.10.2.

## 5 Class E (MF and/or HF only)

### 5.1 Transmit capabilities

5.1.1 Format specifier: Distress  
Geographic area  
Individual station  
Ships having common interest (group).

5.1.2 The numerical identification of the called station (address).

5.1.3 Category: Distress  
Urgency  
Safety  
Routine.

5.1.4 Self-identification (automatically inserted).

### 5.1.5 Messages

5.1.5.1 For distress calls:

Message 1: Nature of distress, defaulting to undesignated distress

Message 2: Distress coordinates

Message 3: Time for last position update

Message 4: Type of subsequent communication J3E.

5.1.5.2 For all other calls:

First telecommand: J3E telephony  
Unable to comply  
Test.

Second telecommand: No information.

Frequency/channel information: MF/HF working channel, on MF defaulting to 2 182 kHz for urgency and safety calls.

5.1.6 End of sequence character: As defined in Annex 1.

### 5.2 Receive capabilities

Receive and be capable of displaying all the information in calls listed in § 5.1 plus all distress relay calls having the format specifier “geographical area calls”, all distress acknowledgement calls and all “unable to comply” calls.

## Annex 3

### Design example

#### User interface for simplified operation of shipborne equipment

##### 1 General

The user interface for operation of the DSC equipment should be so designed that it will be easy for the operator onboard the ship to operate the equipment and to compose and initiate the types of DSC messages provided for by the equipment. The equipment software should allow the operator to only compose the types of DSC messages which are specified in Tables 4.1-4.10.2. These tables indicate which DSC messages are applicable for each class of DSC equipment.

##### 2 Definitions

**2.1 Automated procedure:** the term given to describe the set of actions necessary to complete the objective of an initiating DSC message or non-DSC communication event. Four DSC automated procedures are designed to process these. They are the receiving of distress DSC messages, the receiving of non-distress DSC messages, the sending of distress DSC alert attempts and the sending of non-distress DSC messages. In addition a fifth procedure is designed to handle non-DSC communication events.

These automated procedures are called:

- Received distress automated procedure
- Sending distress automated procedure
- Received non-distress automated procedure
- Sending non-distress automated procedure
- Communications automated procedure.

**2.2 default:** a value selected or an action taken by the equipment software in the absence of any operator input.

**2.3 DROBOSE:** distress relay on behalf of someone else.

**2.4 engaged:** the term used to indicate that the equipment is busy handling an automated procedure.

**2.5 factory default:** a default value that is set by the manufacturer such that the field or behaviour is defined prior to any operator intervention.

**2.6 standby:** the term used to indicate that the equipment is not handling an automated procedure, either active or on hold, but is able to receive DSC messages.

**2.7 top level:** top level means that items, buttons, or functions are present and visible without requiring any action by the operator (such as scrolling, opening up menus, or removing any obscuring covers, etc.).

### 3 Controls

**3.1 Dedicated distress button** to initiate the sending of the distress alert attempt. This button should have at least two independent actions. Lifting of the protective lid is considered the first action. Pressing the distress button is considered as the second independent action. This button should be red in colour and marked “DISTRESS”. Where a non-transparent protective lid or cover is used, it should also be marked “DISTRESS”. The cover should be protected against inadvertent operation with a spring loaded lid or cover permanently attached to the equipment by e.g. hinges. It should not be necessary for the user to remove seals or to break the lid or cover in order to operate the distress button. This button should be used only for this purpose and it should be able to perform this function at all times. Use of the button without any previous operator actions to compose the alert should initiate the default distress alert attempt. The “default distress alert attempt” consists of “undesigned” for the nature of distress, radiotelephony for the communication mode, and on HF the transmission of the attempt uses the multifrequency method including all six bands.

The distress button should have priority over all DSC procedures.

**3.2** The following controls, buttons or functions should be provided and visible at the top level while the equipment is in standby:

**3.2.1 Distress function** for composing distress alert attempts other than the default distress alert attempt where the operator is able to:

- select the nature of distress (the factory default should be undesigned distress),
- on HF select the communication mode (the factory default should be telephone),
- on HF select the method and frequencies of transmission (the factory default should be the multifrequency method on all six bands),
- check the content of the position and time of position information and to manually enter this information if not correct,

prior to initiating the sending of the distress alert attempt with the dedicated distress button.

**3.2.2 Call function** for composing non-distress DSC messages.

**3.2.3 Distress relay on behalf of someone else function** for composing and relaying the occurrence of a distress event obtained by non-DSC means.

**3.3** The following controls, buttons or functions should be provided and be visible as noted:

**3.3.1 Cancel/esc/exit/or equivalent** for returning to a previous menu level from any state of the equipment.

**3.3.2 Enter/accept/next/touch/press or equivalent** for

**3.3.2.1** Accepting a menu item, or

**3.3.2.2** Going to the next step.

### 4 Display of messages in plain language

The headings and content of messages should be shown in plain language, for example:

- “Radiotelephone” instead of J3E,
- “busy” instead of “telecommand 2: 102”.

## 5 Transmission of DSC messages

### 5.1 DSC message composition features

The facilities for choosing and composing DSC messages should be so arranged that it is possible for the operator quickly and precisely to:

- 5.1.1 compose the content of the DSC message,
- 5.1.2 review and correct, if needed, the content before transmitting the DSC message.

### 5.2 Operational guidance to the operator

5.2.1 The operator should only be able to compose the types of DSC messages which are specified in Tables 4.1-4.10.2.

5.2.2 The equipment should automatically propose the next step for composing the DSC message, for example, when pressing the enter/accept/next/touch/press button or equivalent, if not visible from the context or on the display.

### 5.3 Defaults

Where options for the items in the DSC message exist (see Annex 1, Tables 4.1-4.10.2), the factory default values should be as follows:

After the operator selects the option to compose a non-distress DSC message:

- if the operator has the option to select a format (destination address) the default format should be “individual (120)”,
- if the format (destination address) is either individual (120), a group of ships (114), or a semi-automatic phone call (123), the default MMSI should be some internal indicator that the MMSI is invalid and needs to be entered before transmission can occur,
- if the format (destination address) is an area (102), the default area should be a circle of radius 500 nautical miles centred on the ship,
- if the operator has the option to select a category (priority) the default category should be “routine” unless the routine priority is not allowed (such as in an area or all-ships DSC message) in which case it should be “safety”,
- if the operator has the option to select the type of subsequent communication the default value should be radiotelephony,
- if the operator has the option to select a frequency or channel for the subsequent communication the default value should be a non-distress frequency or channel consistent with the means of subsequent communication and on MF/HF in the same band as the DSC message transmission,
  - on MF/HF if the operator has the option to select the frequency of the DSC transmission, default value should be 2 177 kHz,
  - on MF if the operator has the option to select the frequency of the DSC transmission, default value should be 2 177 kHz,
  - on HF if the operator has the option to select the frequency of the DSC transmission, default value should be in the 8 MHz band,
- all other parameters, for example the position, self ID, time of position, and end of sequence character, should be automatically entered by the equipment,

- the category should not be “remembered” when the call composition option is selected at a later time but should be reset to the factory default; this requirement does not mean the equipment is unable to provide the operator with the option to send pre-composed, customized DSC messages with a single action,
- for example, if there is only a single “call” button, menu selection, or equivalent for initiating a non-distress DSC message, the default DSC message should have format “individual” and category “routine”.

After the operator selects the option to compose a distress relay on behalf of someone else (DROBOSE):

- if the operator has the option to select a format (destination address) the default format should be “individual (120)”,
- if the format (destination address) is individual (120), the default MMSI should be some internal indicator that the MMSI is invalid and needs to be entered before transmission can occur,
- if the format (destination address) is an area (102), the default area should be a circle of radius 500 nautical miles centred on the ship,
- the default nature of distress should be “undesignated (107)”,
- the default MMSI for the vessel in distress should be “unknown (five 126s)”,
- the default position and time of position should be unknown,
- the default means of subsequent communication should be radiotelephony,
  - on MF/HF the default band of the DSC transmission should be on the 2 MHz band,
  - on MF the default band of the DSC transmission should be on the 2 MHz band,
  - on HF the default band of the DSC transmission should be on the 8 MHz band,
- all other parameters, for example the, self ID, the distress relay telecommand 1 parameter, the category (distress), and end of sequence character should be automatically entered by the equipment,
- the format, MMSI of the vessel in distress, the nature of distress, the position and time of position should not be “remembered” when the DROBOSE composition option is selected at a later time but should be reset to the defaults.

## 5.4 Other items

**5.4.1** If the called station is a ship station or a group of ship stations the equipment should request input of a channel number (frequency in case of MF). The equipment should assist the operator by suggesting a suitable inter-ship channel; on VHF for example channel 6.

**5.4.2** Automated HF subsequent communication channel selection for non-distress DSC messages. There is a simplex set and duplex set (contains the distress channels) for HF for both voice (3 000 Hz) and data (500 Hz) communication modes. Selection of the appropriate channel from these sets should follow the following steps:

- The band of the communication channel should be the band of the DSC message.
- The telecommand 1 parameter determines the choice of voice or data channels.
- DSC messages directed to a coast station (i.e. MMSI commencing 00) should let the coast station decide.
- All other DSC messages should select a channel from the simplex frequencies.

**5.4.3** Use of the distress channels should be avoided and for routine communications use of the distress channels should not be allowed.



## Annex 4

### Design example

#### Automated procedures for simplified operation in shipborne equipment

##### 1 General

The equipment software should allow the operator to only compose the types of DSC messages which are specified in Tables 4.1-4.10.2. These tables indicate which DSC messages are applicable for each class of DSC equipment.

Automated procedures are the incorporation of ITU-R recommended DSC operational procedures into equipment software.

The equipment should initiate (start) one of five automated procedures whenever the equipment becomes engaged in a new communication event. Four of these automated procedures handle events initiated by sent and received DSC messages and the fifth automated procedure handles radiotelephony established by non-DSC means. One of these five automated procedures is initiated by:

- a) sending a distress alert,
- b) receiving a DSC message containing distress information,
- c) sending an individually addressed relay containing distress information,
- d) sending distress relay on behalf of someone else,
- e) sending a DSC message containing no distress information,
- f) receiving a DSC message containing no distress information,
- g) engaging in traffic initiated by non-DSC means.

Once initiated by any of the events listed in a)-g), the automated procedure should handle all the tasks required to satisfy the objectives of the initiating event. These tasks should include the handling of any subsequent DSC messages that may be pertinent (relevant) to the objectives of the automated procedure and appropriately updating the automated procedure, providing the operator with any possible options, and keeping the operator informed of the progress until either the operator terminates the automated procedure or conditions warrant that the automated procedure self terminates. Automated procedures should be able to be run in parallel. Whereas all DSC automated procedures continuously monitor the watch receiver only one active automated procedure has control of the transmitter and general receiver. The reception of any DSC message not pertinent to an automated procedure should not disrupt that procedure but should be appropriately allocated to the appropriate ongoing automated procedure or initiate a new automated procedure.

##### 2 Definitions

**2.1 acknowledged:** when used to describe an automated procedure it indicates that the objective of the initial DSC message has been achieved.

**2.2 active:** the term used to describe an automated procedure which has control of the general receiver and transmitter and is thus able to engage in subsequent communications and receive DSC messages on both the watch receiver and general receiver.

**2.3 automated procedure:** the term given to describe the set of actions necessary to complete the objective of an initiating DSC message or non-DSC communication event. Four DSC automated procedures are designed to process these. They are the receiving of distress DSC messages, the receiving of non-distress DSC messages, the sending of distress DSC alert attempts and the sending of non-distress DSC messages. In addition a fifth procedure is designed to handle non-DSC communication events.

These automated procedures are called:

- Received distress automated procedure
- Sending distress automated procedure
- Received non-distress automated procedure
- Sending non-distress automated procedure
- Communications automated procedure.

**2.4 critical errors:** a set of information characters obtained from one or more received DSC messages is considered to have critical errors if the automated procedure needs information characters from that set in order to proceed or perform any task, but the required information characters are in error (for example, an acknowledgement cannot be composed to an individual DSC message that has errors in the sender's MMSI).

**2.5 default:** a value selected or an action taken by the equipment software in the absence of any operator input.

**2.6 distress DSC message:** A DSC message or acknowledgement containing the distress information.

**2.7 distress event:** a unique distress situation identified by two (VHF) or three (MF/HF) parameters of the distress information; the MMSI of the vessel in distress and the nature of distress and on MF/HF the mode of subsequent communication.

**2.8 distress information:** the symbols within a DSC message describing a distress situation consisting of the MMSI of the vessel in distress, the nature of distress, the position of the vessel in distress, the UTC time of that position, and the mode of subsequent communication.

**2.9 DROBOSE:** distress relay on behalf of someone else.

**2.10 DX/RX:** a notation used to describe the time diversity structure of DSC messages (see Fig. 1). One has to be careful not to confuse the "RX" notation when used to indicate the symbol position in the DSC message structure (as in § 4.1 of Annex 1) with its use to indicate reception (as in § 8.3.2 of Annex 1).

**2.11 engaged:** the term used to indicate that the equipment is busy handling an automated procedure.

**2.12 factory default:** A default value that is set by the manufacturer such that the field or behaviour is defined prior to any operator intervention.

**2.13 general receiver:** this unit is the receiver part of the transceiver used for the reception of all subsequent communications and on HF the reception of non-distress DSC acknowledgements. It is important to distinguish this unit from the watch receiver (see below).

**2.14 identical:** a set of information characters is considered identical to another set of information characters if all pairs of corresponding information characters are equal or, if a pair of corresponding information characters is not equal, one of the pair is in error.

**2.15 information characters:** the set of symbols in the DSC message that contain the items of interest for the recipient and is used to compute the ECC symbol that terminates the message. These symbols are repeated in the DX/RX time diversity pattern.

**2.16 initial DSC message:** the DSC message that starts an automated procedure.

**2.17 non-distress DSC message:** DSC messages and acknowledgments that do not contain the distress information.

**2.18 objective:** when in reference to a DSC message or automated procedure it is the goal or intent of the item; usually this goal or intent is to establish subsequent communications or request information.

**2.19 on hold:** the term used to describe an automated procedure which does not have access to the transmitter and general receiver and therefore cannot engage in subsequent communications and is only able to receive DSC messages on the watch receiver.

**2.20 operator options:** are any choices the operator can make while the automated procedure is engaged.

**2.21 parallel event handling:** the background process of handling a received DSC message that is not pertinent to the active automated procedure.

**2.22 pertinent to the automated procedure:** an expression used primarily with reference to DSC messages to indicate that the message has something to do with the procedure and is therefore “handled” by the procedure. A DSC message is pertinent to an automated procedure if the set of information characters in the DSC message has the correct values.

**2.23 standby:** the term used to indicate that the equipment is not handling an automated procedure, either active or on hold, but is able to receive DSC messages.

**2.24 two-tone alarm:** an alarm consisting of a repetition of the 2 200 Hz frequency for 250 ms followed by a 1 300 Hz frequency for 250 ms. This alarm is used for the initiation of the received distress DSC automated procedure. The characteristics of this alarm should not be able to be altered.

**2.25 urgency alarm:** an alarm consisting of a repetition of the 2 200 Hz frequency for 250 ms followed by 250 ms period of silence. This alarm is used for the initiation of the received non-distress DSC automated procedure when the category of the initiating DSC message is “urgency”. The characteristics of this alarm should not be able to be altered.

**2.26 watch receiver:** this unit is the separate receiver in DSC radios that continuously monitors the DSC distress frequencies on MF/HF, 2 187.5 kHz on MF, and channel 70 on VHF. On MF/HF it is sometimes referred to as the scanning receiver.

### 3 Tasks of automated procedures

#### 3.1 Tasks common to all automated procedures handling DSC messages

##### 3.1.1 Handling alarms

**3.1.1.1** The sounding of any alarm should simultaneously display the reason for the alarm and the means to silence it.

**3.1.1.2** Alarms should sound appropriate to the automated procedure when a received DSC message either initiates or acknowledges the automated procedure with the two-tone alarm being reserved for the initiation of the received distress procedure, and the urgency alarm being reserved for the initiation of the received non-distress procedure when the category of the initiating DSC message is “urgency”.

**3.1.1.3** Only the **first** occurrence of a received DSC message should sound the alarms described in § 3.1.1.2.

**3.1.1.4** All received DSC messages that do not sound an alarm as specified in § 3.1.1.2 should sound a brief, self-terminating alarm to inform the operator of the reception.

### **3.1.2 Displaying stages of the automated procedure**

The automated procedure should display the stages and/or activity in order to indicate the progress of the procedure.

### **3.1.3 Tuning the radio**

**3.1.3.1** Tuning of the general receiver and transmitter for reception or transmission of required acknowledgments, repeat transmissions, relays, or subsequent communications should be handled automatically.

**3.1.3.2** Any automated tuning action that could potentially disrupt ongoing subsequent communications should provide the operator with at least a 10 s warning. The operator should then be provided with the opportunity to pause the action. In the absence of operator intervention the automated action should proceed.

### **3.1.4 Displaying operator options**

Options should only be provided at those times the option is appropriate.

### **3.1.5 Handling DSC messages not pertinent to the active procedure**

The received DSC message is either allocated to the correct automated procedure running in the background on hold or initiates a new automated procedure on hold.

### **3.1.6 Displaying warnings**

Warnings should be displayed when the operator attempts to do anything that does not follow the guidelines given by ITU and IMO. The operator should have the option to go back to the stage of the automated procedure where the action was taken that caused the warning.

### **3.1.7 Handling DSC messages containing errors**

**3.1.7.1** A DSC message with errors is pertinent to an automated procedure if the set of information characters in the DSC message is **identical** as defined in the “definitions” section to the set of information characters normally used to determine pertinence.

**3.1.7.2** Automated procedures initiated by DSC messages with critical errors should sound the same alarm they would sound if the DSC message were received error free but the alarm should self-terminate.

**3.1.7.3** Automated procedures are encouraged to utilize subsequent DSC messages pertinent to the automated procedure to reduce the number of receive errors in the set of information characters that are important to the automated procedure. In no case should the reception of subsequent DSC messages increase the number of errors in the set of information characters important to the automated procedure.

**3.1.7.4** No automated procedure should allow the transmission of further DSC messages with errors.

**3.1.7.5** If critical errors prevent an automated procedure from setting up an operator option or performing any automated action, that option should be disabled or that action not performed.

**3.1.7.6** Automated procedures should not be considered acknowledged until all the critical errors in the set of acknowledgement information characters have been received correctly or corrected by repeat reception.

**3.1.7.7** Information that is normally displayed that contains errors should be displayed to the full extent possible; for example, digits in the MMSI or position information that are received correctly should be displayed in their correct positions and those that are not should be indicated by some special error symbol.

### **3.1.8 Transmission of DSC messages**

Transmission of DSC messages should use a prioritized wait scheme. If the channel is not free, and the DSC message is a distress alert, the alert should be transmitted as soon as the channel becomes free or after 10 s on MF or HF or 1 s on VHF, whichever occurs first. For all other DSC messages, the automated procedure should wait for the channel to become free and then delay transmission of the DSC message for a specified wait time. Distress DSC messages (except for alerts), urgency, safety, routine and test DSC messages should wait one, two, three, and four “fixed” units of time plus a random addition described below, respectively, before attempting to transmit. Transmission occurs if and only if the channel is still free after this wait time has elapsed, otherwise the process is repeated. The fixed “unit” of time should be 100 ms on MF and HF and 50 ms on VHF. The randomly generated component should be some positive integer with resolution in milliseconds between zero and the fixed interval. On MF/HF the channel is considered free if the receiver hardware or DSP software is unable to recognize the DSC tones.

### **3.1.9 Automated termination**

**3.1.9.1** Automated procedures should have an automated termination timer whose factory default values can be changed by the operator. It should be possible to disable this timer. Unacknowledged sending distress automated procedures should **not** have a termination timer, however after acknowledgement a termination timer is optional.

**3.1.9.2** At least 10 s prior to automatic termination, a warning with a discrete aural alarm should be displayed giving the operator the opportunity to stop the termination.

## **3.2 Tasks specific to certain automated procedures**

### **3.2.1 Tasks of automated procedures initiated by receiving non-distress DSC messages**

#### **3.2.1.1 Display of elapsed time**

The elapsed time since receiving the initiating DSC message should be displayed or after any requested acknowledgment has been sent, the elapsed time since sending the acknowledgement should be displayed. Sending repeat acknowledgments should not affect the time display.

#### **3.2.1.2 Handling acknowledgments**

**3.2.1.2.1** If the equipment has been set up to automatically acknowledge individually addressed polling, position request, or test DSC messages, no alarm should sound and the automated procedure should self-terminate.

**3.2.1.2.2** All individually addressed DSC messages with subsequent communications should be automatically acknowledged as a default. In this case the alarm should sound after the acknowledgement is sent.

**3.2.1.2.3** Acknowledgement options should only be made available to the operator when the received DSC message requests an acknowledgement.

**3.2.1.2.4** When acknowledgments are requested the automated procedure should provide the operator with up to three possible acknowledgement options based upon the received DSC message as follows:

**3.2.1.2.4.1** Able to comply: This option should be provided if the frequencies and mode of subsequent communication are provided by the received DSC message and the equipment is capable of handling the requested communications, or if the received DSC message is a polling, position request, or test that has not been automatically acknowledged.

**3.2.1.2.4.2** Able to comply with a mode or frequency change: This option should be provided if the received DSC message requests subsequent communications.

**3.2.1.2.4.3** Unable to comply: This option should be provided if the received DSC message contains subsequent communications or is a position request. The sending of this acknowledgement indicates a refusal and should terminate the automated procedure.

**3.2.1.2.5** The automated procedure should automatically compose the acknowledgement messages based upon the received DSC message as shown in Fig. 2 and Fig. 3.

**3.2.1.2.5.1** “Able to comply” acknowledgments should be composed in entirety by the automated procedure.

**3.2.1.2.5.2** “Able to comply with a mode or frequency change” acknowledgments should only require the entry/selection of a new mode and/or frequency.

**3.2.1.2.5.3** “Unable to comply” acknowledgments to DSC messages containing subsequent communications should only require the entry/selection of one of the ten telecommand 2 “reason” symbols specified in Table 3.

**3.2.1.2.5.4** “Unable to comply” acknowledgments to position requests if implemented should only require a single action by the operator to send. The procedure should automatically place the “no information symbol” in the position and time messages of the acknowledgement.

**3.2.1.2.6** The operator should be able to resend a duplicate of the first acknowledgement in automated procedures that have subsequent communications.

## **3.2.2 Tasks of automated procedures initiated by sending a non-distress DSC message**

### **3.2.2.1 Display of elapsed time**

The elapsed time since sending the initial DSC message should be displayed or after the automated procedure has received a requested acknowledgment, the elapsed time since acknowledgement should be displayed. Receiving repeat acknowledgments should not affect the time display.

### **3.2.2.2 Resending the initial DSC message**

**3.2.2.2.1** If no acknowledgement is requested the option to resend the initial DSC message should remain available until the procedure is terminated.

**3.2.2.2.2** If an acknowledgement is requested the option to resend the initial DSC message should remain available until the acknowledgment has been received.

### **3.2.2.3 Handling the reception of a delayed acknowledgement**

If an acknowledgement appropriate to this automated procedure is received but the operator has terminated the automated procedure prematurely, the appropriate automated procedure should be reconstructed based on the acknowledgement and the operator informed of the situation.

## **3.2.3 Tasks of automated procedures initiated by receiving a distress DSC message or sending a distress relay on behalf of someone else**

### **3.2.3.1 Display of elapsed time**

The elapsed time since receiving the initial DSC message should be displayed or after the automated procedure has been acknowledged, the elapsed time since acknowledgement should be displayed. Receiving repeat acknowledgments should not affect the time display.

### **3.2.3.2 Determining operator options**

**3.2.3.2.1** On HF the operator should have the option to set the general receiver and transmitter to any one of the six distress frequencies of subsequent communication.

**3.2.3.2.2** The option to send a relay should always be available until the automated procedure is terminated.

### **3.2.3.2.3 Distress alert acknowledgments and relay acknowledgement options**

**3.2.3.2.3.1** These options should not be made available until a DSC message has been received that can respond to the acknowledgement.

**3.2.3.2.3.2** These options should be available immediately after reception of the appropriate DSC messages and **not** wait until certain conditions for their use, such as time limits, are fulfilled.

**3.2.3.2.3.3** Once these options are available, they should remain available until the automated procedure is terminated.

### **3.2.3.3 DSC message composition**

**3.2.3.3.1** The automated procedure should automatically compose relays, distress alert acknowledgments and relay acknowledgments based upon the received DSC messages.

**3.2.3.3.1.1** The distress information should be taken from the distress DSC message which has the latest UTC time stamp.

**3.2.3.3.1.2** Distress alert acknowledgements and relay acknowledgements should require no data entry by the operator except on HF where the frequency of the DSC message may be selected.

**3.2.3.3.2** Relays should only allow the entry of the addressing mode (format) and destination address and on HF, the mode of subsequent communication and the frequency of the DSC message.

**3.2.3.3.3** On HF the automated procedure should indicate those frequencies on which DSC messages pertinent to the automated procedure have been received as the preferred choices, however the operator should be allowed to choose any of the six distress frequencies.

### **3.2.3.4 Tuning of the radio after acknowledgment on HF**

The automated tuning should cease upon reception or sending of a distress alert acknowledgement or a distress relay acknowledgment addressed to multiple stations. However, the operator should be provided with sufficient information to manually tune to the working frequencies of the most recently received DSC message.

### **3.2.3.5 Handling individually addressed relays**

**3.2.3.5.1** The sending or receiving of individually addressed relays should initiate their own automated procedure separate from the automated procedure that may be handling distress DSC messages concerning the same distress event.

**3.2.3.5.2** The option to send a distress alert acknowledgement should never be available during this automated procedure.

### **3.2.3.6 Handling DSC messages with critical errors**

If the subsequent communication parameter of the distress information is received in error, radiotelephone should be assumed and an indication that the parameter was received in error should be made known to the operator.

### **3.2.3.7 Handling the self-addressed distress alert acknowledgement**

If the MMSI of the sender of a distress alert acknowledgement is the same as the MMSI of the vessel in distress, the automated procedure should recognize the message as an attempt to cancel the distress alert and inform the operator accordingly.

### **3.2.3.8 Extended DSC sentences**

The automated procedure should be able to successfully receive and decode single frequency alert attempts that have extended sentence information at the end of some or all of the individual alerts.

### **3.2.3.9 MF/HF only scanning for distress DSC messages**

The received distress automated procedure should scan all six distress DSC channels if not already doing so.

## **3.2.4 Tasks of automated procedures initiated by sending a distress alert attempt**

### **3.2.4.1 Display of elapsed time**

**3.2.4.1.1** The time remaining to the sending of the next distress alert attempt should be displayed prior to acknowledgment by DSC.

**3.2.4.1.2** The elapsed time since acknowledgement should be displayed after acknowledgment by DSC. Receiving repeat acknowledgments should not affect the time display.

### **3.2.4.2 Resending of the distress alert attempt**

**3.2.4.2.1** The unacknowledged distress alert attempt should be automatically resent after a 3.5 to 4.5 min wait.

**3.2.4.2.2** The automatic resending of the distress alert attempt should automatically terminate after acknowledgement by DSC.

**3.2.4.2.3** Resent distress alert attempts should contain updated position and time of position information.

### **3.2.4.3 Determining operator options**

**3.2.4.3.1** The option to manually resend the distress alert attempt at any time should remain available until the distress alert has been acknowledged by DSC.

**3.2.4.3.2** On HF the operator should have the option to change the frequencies of the distress alert attempt and the option to select between the single frequency or multifrequency method.



**3.2.4.3.3** The option to pause the countdown to the next distress alert attempt should be available prior to acknowledgement by DSC.

**3.2.4.3.4** The option to cancel the distress alert should be available prior to acknowledgement by DSC.

**3.2.4.3.5** The option to terminate the procedure should only be available after acknowledgment by DSC.

#### **3.2.4.4 The distress alert cancel procedure**

The *cancel procedure* consists of the *cancel operation* on all bands utilized by the distress alert attempts (on VHF and MF there is only one *cancel operation* whereas on MF/HF there may be up to six). The *cancel operation* consists of a DSC cancel message (a self-addressed distress alert acknowledgement) followed by a *voice cancel* on the corresponding frequency of subsequent communication. The phrase “*voice cancel*” refers to the part of the cancel done over the subsequent communication frequencies whether it is by radiotelephony or on MF and MF/HF by data.

**3.2.4.4.1** Upon selection of the cancel option the sending distress automated procedure should provide an explanation of the *cancel procedure* to the operator and provide the option to either continue or return and not do the cancel.

**3.2.4.4.2** If the operator selects to proceed with the *cancel procedure* the sending distress automated procedure should pause the countdown to the next automated sending of the distress alert attempt and wait (if necessary) until any alert within an attempt is transmitted to completion before allowing the operator to initiate the first *cancel operation*.

**3.2.4.4.3** The operator options during the *cancel procedure* should be to terminate the cancel procedure and to start the *cancel operation*.

**3.2.4.4.4** If the *cancel procedure* is terminated before the first *cancel operation* is started, the sending distress automated procedure should resume from where it left off. However, once the *cancel operation* is started, the option to terminate the *cancel procedure* should not be available until the *cancel procedure* is completed.

**3.2.4.4.5** The status of the *cancel procedure* should be displayed.

**3.2.4.4.6** The operator should be provided with the appropriate text for the *voice cancel* at the time of the *voice cancel*.

**3.2.4.4.7** The *cancel operation* should be able to be repeated on any band but a warning should be provided that the cancel has already been done on this band.

#### **3.2.4.4.8 Special considerations for MF/HF**

**3.2.4.4.8.1** The status of each of the bands should be displayed;

**3.2.4.4.8.2** Once one band is cancelled the option to end the *cancel procedure* should not be available until ALL utilized bands are cancelled;

**3.2.4.4.8.3** When the *cancel procedure* is completed, the sending distress automated procedure should be considered acknowledged and the fact that a cancel was performed should be displayed.

#### **3.2.4.5 MF/HF only scanning for distress alert acknowledgements**

The sending distress automated procedure should scan all six distress DSC channels if not already doing so.

### **3.2.5 Radiotelephone communications automated procedure**

The equipment should also be provided with a communications function for radiotelephony that is compatible with the DSC automated procedures described in this Annex. This automated procedure should have:

- 3.2.5.1 the ability to switch between being active or being on hold at the discretion of the operator,
- 3.2.5.2 the ability to be terminated at the discretion of the operator,
- 3.2.5.3 the ability to select the channels for the communications, and

### **3.2.6 Other non-DSC automated procedures**

Any other non-DSC functionality that is included in the equipment should:

- 3.2.6.1 be able to be activated or placed on hold at the discretion of the operator,
- 3.2.6.2 never control the watch receiver such that DSC automated procedures, either active or on hold, are unable to receive DSC messages on the watch receiver,
- 3.2.6.3 be able to be terminated by the operator.

## **3.3 Tasks concerning multiple automated procedures**

### **3.3.1 Number of simultaneous automated procedures**

Facilities should be provided to handle a minimum of seven simultaneous automated procedures including a reserve of one. The initiation of the reserve automated procedure should:

- warn the operator that the equipment cannot handle another automated procedure and that one automated procedure should be terminated,
- prevent the operator from initiating any new automated procedures except for the sending of a distress alert and,
- warn the operator that the reception of an additional DSC message that would initiate an automated procedure if the equipment were in standby will result in the automatic and immediate termination of an inactive automated procedure where,
- the automatic and immediate termination should be based upon age and priority.

### **3.3.2 Sending distress automated procedure**

When initiating a sending distress automated procedure, automatic immediate termination of all other automated procedures (if any) is encouraged but not required.

### **3.3.3 Operator options**

3.3.3.1 The operator should be able to freely navigate between the automated procedures except when engaged in an unacknowledged sending distress automated procedure.

3.3.3.2 When the operator makes any one of the automated procedures on hold active, the automated procedure that was active (if any) should automatically go on hold.

### **3.3.4 Unacknowledged poll, test, or position request automated procedures received on hold**

If any of these automated procedures is set to automatically acknowledge, it should automatically acknowledge and self terminate as soon as all remaining automated procedures are on hold.

### 3.4 Warnings

Warnings should be provided when the *operator* attempts to do the following:

- 3.4.1 send a relay before three minutes have elapsed since the automated procedure started,
  - 3.4.2 send a non-individually addressed relay,
  - 3.4.3 send a distress alert acknowledgement (requires coast station permission),
  - 3.4.4 send an all stations (116 format) distress relay acknowledgement (should be sent by coast station only),
  - 3.4.5 send an acknowledgement to a DSC message containing no distress information that is not individually addressed,
  - 3.4.6 cancel a distress alert,
  - 3.4.7 send any DSC message after the objective of the automated procedure has been obtained,
  - 3.4.8 terminate the automated procedure before the objective has been reached,
  - 3.4.9 terminate the automated procedure if engaged in subsequent communications.
-