

International Telecommunication Union

**ITU-R**  
Radiocommunication Sector of ITU

**Recommendation ITU-R SM.1541-6**  
(08/2015)

**Unwanted emissions in the  
out-of-band domain**

**SM Series**  
**Spectrum management**

**150**   
1865-2015

 **ITU**  
International  
Telecommunication  
Union

## Foreword

The role of the Radiocommunication Sector is to ensure the rational, equitable, efficient and economical use of the radio-frequency spectrum by all radiocommunication services, including satellite services, and carry out studies without limit of frequency range on the basis of which Recommendations are adopted.

The regulatory and policy functions of the Radiocommunication Sector are performed by World and Regional Radiocommunication Conferences and Radiocommunication Assemblies supported by Study Groups.

## Policy on Intellectual Property Right (IPR)

ITU-R policy on IPR is described in the Common Patent Policy for ITU-T/ITU-R/ISO/IEC referenced in Resolution ITU-R 1. Forms to be used for the submission of patent statements and licensing declarations by patent holders are available from <http://www.itu.int/ITU-R/go/patents/en> where the Guidelines for Implementation of the Common Patent Policy for ITU-T/ITU-R/ISO/IEC and the ITU-R patent information database can also be found.

### Series of ITU-R Recommendations

(Also available online at <http://www.itu.int/publ/R-REC/en>)

Series	Title
<b>BO</b>	Satellite delivery
<b>BR</b>	Recording for production, archival and play-out; film for television
<b>BS</b>	Broadcasting service (sound)
<b>BT</b>	Broadcasting service (television)
<b>F</b>	Fixed service
<b>M</b>	Mobile, radiodetermination, amateur and related satellite services
<b>P</b>	Radiowave propagation
<b>RA</b>	Radio astronomy
<b>RS</b>	Remote sensing systems
<b>S</b>	Fixed-satellite service
<b>SA</b>	Space applications and meteorology
<b>SF</b>	Frequency sharing and coordination between fixed-satellite and fixed service systems
<b>SM</b>	<b>Spectrum management</b>
<b>SNG</b>	Satellite news gathering
<b>TF</b>	Time signals and frequency standards emissions
<b>V</b>	Vocabulary and related subjects

*Note: This ITU-R Recommendation was approved in English under the procedure detailed in Resolution ITU-R 1.*

Electronic Publication  
Geneva, 2015

© ITU 2015

All rights reserved. No part of this publication may be reproduced, by any means whatsoever, without written permission of ITU.

## RECOMMENDATION ITU-R SM.1541-6\*, \*\*

**Unwanted emissions in the out-of-band domain\*\*\***

(2001-2002-2006-01/2011-09/2011-2013-2015)

**Scope**

This Recommendation provides out-of-band (OoB) domain emission limits for transmitters in the frequency range of 9 kHz to 300 GHz.

**Keywords**

Unwanted emissions, out-of-band domain, emission limits

The ITU Radiocommunication Assembly,

*considering*

- a) that Recommendation ITU-R SM.329 – Unwanted emissions in the spurious domain, relates to the effects, measurements and limits to be applied to unwanted emissions in the spurious domain;
- b) that Recommendations ITU-R SM.329 and ITU-R SM.1539 provide guidance for determining the boundary between the out-of-band (OoB) and spurious domains in a transmitted radio frequency spectrum;
- c) that considerations of OoB domain and necessary bandwidths are included by necessity in Recommendation ITU-R SM.328 – Spectra and bandwidth of emissions;
- d) that unwanted emissions occur after a transmitter is brought into operation and can be reduced by system design;
- e) that OoB domain emission limits have been successfully used as national or regional regulations in areas having a high radiocommunications density; such limits are generally designed according to specific and detailed local needs for coexistence with other systems;
- f) that nevertheless there is a need, for each service, for a limited number of a more broadly generic ITU-R OoB domain emission limits, generally based on an envelope of the least restrictive OoB domain emission limits described in the above *considering* e);
- g) that where frequency assignments are provided to the Radiocommunication Bureau (BR) in accordance with Appendix 4 of the Radio Regulations (RR), the necessary bandwidth of an emission with a single carrier is given by the bandwidth portion of the emission designator;
- h) that the necessary bandwidth, referred to in RR Appendix 4 is for a single carrier transmission, and may not adequately cover the case of systems with multiple carriers,

---

\* This Recommendation should be brought to the attention of Radiocommunication Study Groups 4, 5, 6 and 7.

\*\* Radiocommunication Study Group 1 made editorial amendments to this Recommendation in the year 2019 in accordance with Resolution ITU-R 1.

\*\*\* Although OoB emissions are generally predominant in the OoB domain, spurious emissions may also occur in the OoB domain. It is important to note that the limits in this Recommendation apply to all the unwanted emissions in the OoB domain, both OoB emissions and spurious emissions.

*recognizing*

that the following terms are defined in the RR.

### **Unwanted emissions**

«1.146 unwanted emissions\*: Consist of spurious emissions and out-of-band emissions.»

### **Spurious emission**

«1.145 *spurious emission*\*: Emission on a frequency or frequencies which are outside the *necessary bandwidth* and the level of which may be reduced without affecting the corresponding transmission of information. Spurious emissions include harmonic *emissions*, parasitic *emissions*, intermodulation products and frequency conversion products, but exclude *out-of-band emissions*.»

### **Out-of-band emission**

«1.144 *out-of-band emission*\*: Emission on a frequency or frequencies immediately outside the *necessary bandwidth* which results from the modulation process, but excluding *spurious emissions*.»

### **Occupied bandwidth**

«1.153 *occupied bandwidth*: The width of a frequency band such that, below the lower and above the upper frequency limits, the *mean powers* emitted are each equal to a specified percentage  $\beta/2$  of the total *mean power* of a given *emission*.

Unless otherwise specified in an ITU-R Recommendation for the appropriate *class of emission*, the value of  $\beta/2$  should be taken as 0.5%.»

### **Necessary bandwidth**

«1.152 *necessary bandwidth*: For a given *class of emission*, the width of the frequency band which is just sufficient to ensure the transmission of information at the rate and with the quality required under specified conditions.»

### **Assigned frequency band**

«1.147 *assigned frequency band*: The frequency band within which the *emission* of a *station* is authorized; the width of the band equals the *necessary bandwidth* plus twice the absolute value of the *frequency tolerance*. Where *space stations* are concerned, the assigned frequency band includes twice the maximum Doppler shift that may occur in relation to any point of the Earth's surface.»

### **Assigned frequency**

«1.148 *assigned frequency*: The centre of the frequency band assigned to a *station*.»

*noting*

a) that Recommendation ITU-R SM.1540 additionally covers cases of unwanted emissions in the OoB domain falling into adjacent allocated bands;

b) that the studies required by Question ITU-R 222/1, approved by Radiocommunication Assembly 2000, could have formal and substantial impact to basic definitions used in this Recommendation. It may be necessary to revise this Recommendation in the future to reflect the results of these studies,

*recommends*

## **1 Terminology and definitions**

that the following additional terms and definitions should be used:

### **1.1 Spurious domain<sup>1</sup>**

(of an emission): the frequency range beyond the OoB domain in which spurious emissions generally predominate.

### **1.2 OoB domain<sup>1</sup>**

(of an emission): the frequency range, immediately outside the necessary bandwidth but excluding the spurious domain, in which OoB emissions generally predominate.

### **1.3 dBsd and dBasd**

**dBsd:** decibels relative to the maximum value of power spectral density (psd) within the necessary bandwidth. The maximum value of psd of a random signal is found by determining the mean power in the reference bandwidth when that reference bandwidth is positioned in frequency such that the result is maximized. The reference bandwidth should be the same regardless of where it is centred and is as specified in § 1.6.

**dBasd:** decibels relative to the average value of psd within the necessary bandwidth. The average value of psd of a random signal is found by computing the mean power in the reference bandwidth and averaging that result over the necessary bandwidth. The reference bandwidth is as specified in § 1.6.

### **1.4 dBc**

Decibels relative to the unmodulated carrier power of the emission. In the cases which do not have a carrier, for example in some digital modulation schemes where the carrier is not accessible for measurement, the reference level equivalent to dBc is dB relative to the mean power  $P$ .

### **1.5 dBpp**

Decibels relative to the maximum value of the peak power, measured with the reference bandwidth within the occupied bandwidth. The in-band peak power is expressed in the same reference bandwidth as the OoB peak power. Both the in-band and the unwanted emissions should be evaluated in terms of peak values. For radar systems, the reference bandwidth should be selected according to Recommendation ITU-R M.1177.

---

<sup>1</sup> The terms “OoB domain” and “spurious domain” have been introduced in order to remove some inconsistency now existing between, on one hand, the definition of the terms “out-of-band emission” and “spurious emission” in RR Article 1 and, on the other hand, the actual use of these terms in RR Appendix 3, as revised by World Radiocommunication Conference (Istanbul, 2000) (WRC-2000). OoB and spurious limits apply, respectively, to all unwanted emissions in the OoB and spurious domains.

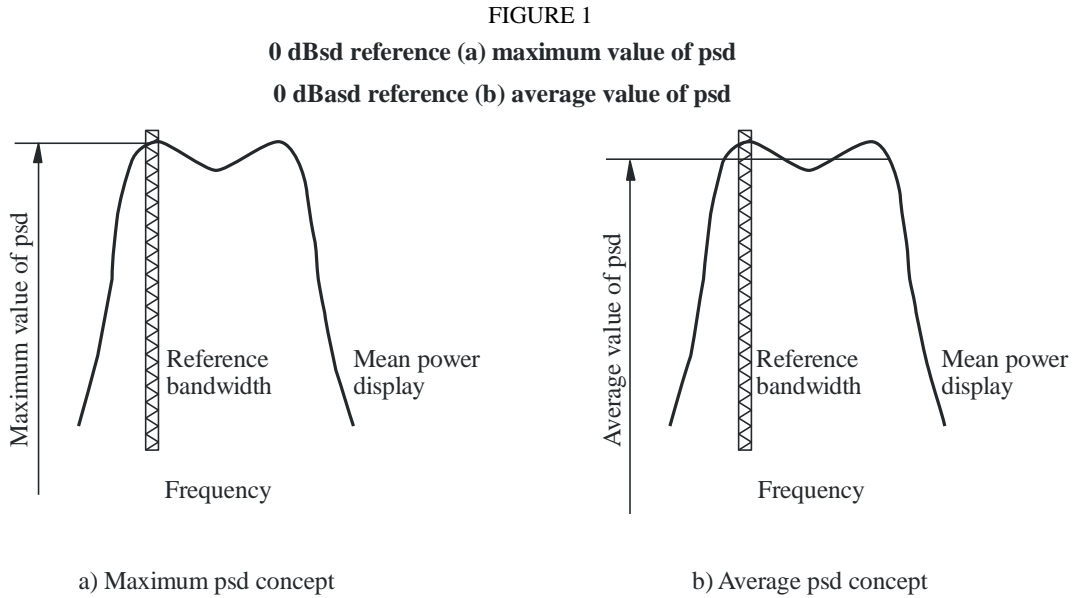

SM1541-01

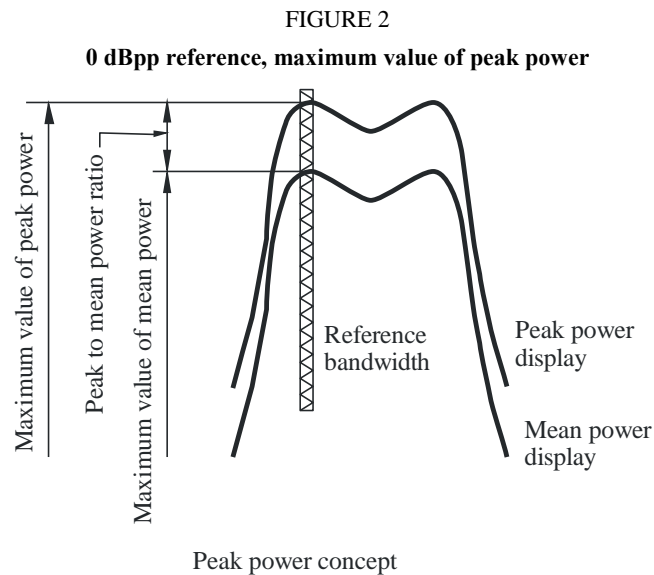

SM1541-02

## 1.6 Reference bandwidth

The bandwidth required for uniquely defining the OoB domain emission limits. If not explicitly given with the OoB domain emission limit, the reference bandwidth should be 1% of the necessary bandwidth. For radar systems the reference bandwidth should be selected in line with Recommendation ITU-R M.1177.

## 1.7 Measurement bandwidth

The bandwidth which is technically appropriate for the measurement of a specific system. In common spectrum analysers this is generally referred as the resolution bandwidth.

NOTE 1 – The measurement bandwidth may differ from the reference bandwidth, provided the results can be converted to the required reference bandwidth.

## **1.8 psd**

For the purpose of this Recommendation, psd is the mean power per reference bandwidth.

## **1.9 Mean power**

Power integrated over a specified frequency band using measurements of the psd or an equivalent method.

## **1.10 Adjacent channel mean power**

Power integrated over the bandwidth of a channel adjacent to an occupied channel using measurements of the psd or an equivalent method.

## **1.11 Peak power**

Power measured with the peak detector using a filter the width and shape of which is sufficient to accept the signal bandwidth.

## **1.12 Adjacent channel peak power**

Peak power measured in the bandwidth of a channel adjacent to an occupied channel using a specified channel filter.

## **1.13 Total assigned band**

Sum of contiguous assigned bands of a system consistent with the RR Appendix 4 data provided to the BR and as authorized by an administration.

NOTE 1 – For space services, when a system has multiple transponders/transmitters that operate in adjacent bands separated by a guardband, the total assigned band should include the guardbands. In such cases, the guardbands should be a small percentage of the transponder/transmitter bandwidth.

## **1.14 Total assigned bandwidth**

The width of the total assigned band;

## **2 Application of definitions**

that, when applying this Recommendation, guidance should be taken from the following:

### **2.1 OoB domain emissions**

Any emission outside the necessary bandwidth which occurs in the frequency range separated from the assigned frequency of the emission by less than 250% of the necessary bandwidth of the emission will generally be considered an emission in the OoB domain. However, this frequency separation may be dependent on the type of modulation, the maximum symbol rate in the case of digital modulation, the type of transmitter, and frequency coordination factors. For example, in the case of some digital, broadband, or pulse modulated systems, the frequency separation may need to differ from the 250% factor.

Transmitter non-linearities may also spread in-band signal components into the frequency band of the OoB frequency ranges described in Annex 1, § 1.3. Further, transmitter oscillator sideband noise also may extend into that frequency range described in Annex 1, § 1.3. Since it may not be practical to isolate these emissions their level will tend to be included during OoB power measurements.

## 2.2 Spurious domain emissions

For the purpose of this Recommendation all emissions, including intermodulation products, conversion products and parasitic emissions, which fall at frequencies separated from the centre frequency of the emission by 250% or more of the necessary bandwidth of the emission will generally be considered as emissions in the spurious domain. However, this frequency separation may be dependent on the type of modulation, the maximum symbol rate in the case of digital modulation, the type of transmitter, and frequency coordination factors. For example, in the case of some digital, broadband, or pulse-modulated systems, the frequency separation may need to differ from the 250% factor.

For multichannel or multicarrier transmitters/transponders, where several carriers may be transmitted simultaneously from a final output amplifier or an active antenna, the centre frequency of the emission is taken to be the centre of either the assigned bandwidth of the station or of the  $-3$  dB bandwidth of the transmitter/transponder, using the lesser of the two bandwidths.

## 2.3 Necessary bandwidth and OoB domain

In the case of narrow-band or wideband emissions (as defined in Recommendation ITU-R SM.1539), the extent of the OoB domain should be determined by using Table 1.

TABLE 1  
Start and end of OoB domain

Type of emission	If necessary bandwidth $B_N$ is:	Offset ( $\pm$ ) from the centre of the necessary bandwidth for the start of the OoB domain	Frequency separation between the centre frequency and the spurious boundary
Narrow-band	$< B_L$ (see Note 1)	$0.5 B_N$	$2.5 B_L$
Normal	$B_L$ to $B_U$	$0.5 B_N$	$2.5 B_N$
Wideband	$> B_U$	$0.5 B_N$	$B_U + (1.5 B_N)$

NOTE 1 – When  $B_N < B_L$ , no attenuation of unwanted emissions is recommended at frequency separations between  $0.5 B_N$  to  $0.5 B_L$ .

NOTE 2 –  $B_L$  and  $B_U$  are given in Recommendation ITU-R SM.1539.

### 2.3.1 Single carrier emissions

The value of necessary bandwidth that should be used for checking whether a single carrier emission complies with limits in the OoB domain should coincide with the value in the emission designator provided to the BR in accordance with RR Appendix 4.

Some systems specify the OoB mask in terms of channel bandwidth or channel separation. These may be used as a substitute for necessary bandwidth provided they are found in ITU-R Recommendations or in relevant regional and national regulations.

### 2.3.2 Multicarrier emissions

Multicarrier transmitters/transponders are those where multiple carriers may be transmitted simultaneously from a final amplifier or an active antenna.

For systems with multiple carriers, the OoB domain should start at the edges of the total assigned bandwidth. For satellite systems, the necessary bandwidth used in the OoB masks provided in Annex 5 of this Recommendation and to determine the width of the OoB domain should be taken to



be the lesser of 3 dB transponder bandwidth or the total assigned bandwidth (Annex 2 provides two examples showing how to calculate the start and end of the OoB domain for multicarrier systems with single and multiple transponders per satellite).

For space services, the above definition of necessary bandwidth applies when all or some of the carriers are being transmitted simultaneously.

## **2.4 Considerations on dBsd, dBc, and dBpp**

### **2.4.1 Positive and negative signs for dBsd, dBc, and dBpp**

Since dBsd is defined as relative to some reference power spectral density, the OoB dBsd value is expressed using a negative number (for the usual case where the OoB psd is lower than the reference psd). However, if a term such as “dBsd below” or “Attenuation (dBsd)” is used, then the OoB domain emission value is expressed using a positive number.

Since dBc is defined as relative to some reference power, the OoB dBc value is expressed using a negative number. However, if a term such as “dBc below” or “Attenuation (dBc)” is used, then the OoB domain emission value is expressed using a positive number.

Since dBpp is defined as relative to some reference peak power, the OoB dBpp value is expressed using a negative number. However, if a term such as “dBpp below” or “Attenuation (dBpp)” is used, then the OoB domain emission value is expressed using a positive number.

Annex 3 provides the way to label X and Y axes on dBc and dBsd masks.

### **2.4.2 Comparisons of dBsd and dBc**

Since dBsd and dBc do not have the same 0 dB reference, the same numeric dB value may cause dBsd emission limits that are more stringent than dBc emission limits. The chosen reference bandwidth will affect the amount of this difference. Thus, the type of mask, reference bandwidth, and mask values need to be established together.

### **2.4.3 Practical application of dBsd, dBc, and dBpp limits**

dBsd may be more practical for the following applications:

- digital modulation;
- modulation formats in which measurement of the carrier is impractical.

dBc may be more practical for the following applications:

- analogue modulation;
- specific digital modulation systems;
- subsidiary limits for discrete emissions contained in the OoB domain when spectral density is specified in dBsd values.

dBpp may be more practical for the following applications:

- specific pulsed modulation systems, e.g. radar, and certain specific analogue transmission systems;

## **3 Methods to determine conformance to OoB domain emission limits**

that the adjacent channel and alternate adjacent channel power method or the OoB spectrum mask method described in Annex 1 should be used to determine conformance to OoB domain emission requirements;

#### 4 OoB domain emission limits for transmitters in the range of 9 kHz to 300 GHz<sup>2</sup>

that the spectrum limits specified in this Recommendation should be regarded as generic limits, which generally constitute the least restrictive OoB emission limits successfully used as national or regional regulations. These are sometimes called safety net limits. They are intended for use in bands where tighter limits are not otherwise required to protect specific applications (e.g. in areas having a high radiocommunications density).

On this basis, the OoB domain emissions, to be applied to transmitters in the range of 9 kHz to 300 GHz, should be limited as given in Table 2.

The applicability of Recommendations ITU-R SM.1541 and ITU-R SM.1540 is described in Annex 14.

The development of more specific OoB domain emission limits for each system and in each frequency band should be encouraged by administrations. These limits would take into account the actual application, modulation, filtering capabilities of the system and would take care about co-frequency or adjacent bands operating systems, with a view to enhancing compatibility with other radio services.

Examples of ITU-R Recommendations providing such more specific OoB emission limits for some systems in some frequency bands are listed in Annex 4.

TABLE 2

#### OoB domain emission spectrum limiting curves

Service category in accordance with RR Article 1, or equipment type	Emission mask
Space services (earth and space stations)	See Annex 5
Broadcast television	See Annex 6
Sound broadcasting	See Annex 7
Radar	See Annex 8
Amateur services	See Annex 9
Land mobile service	See Annex 10
Maritime and aeronautical mobile services	See Annex 11
Fixed service	See Annex 12

Compliance with emission limits contained in this Recommendation may not preclude the occurrence of interference. Therefore, compliance with the standard does not obviate the need for cooperation in resolving and implementing engineering solutions to harmful interference problem;

#### 5 Adaptation of OoB masks provided in Annexes 5 to 12 in the cases of narrow-band and wideband systems

- a) that in cases where the necessary bandwidth  $B_N$  is less than  $B_L$  as defined in Recommendation ITU-R SM.1539, the OoB mask should be scaled. This can be done by replacing  $B_N$  by  $B_L$ ;
- b) in cases where the necessary bandwidth  $B_N$  is greater than  $B_U$  as defined in Recommendation ITU-R SM.1539, the value of  $B_N$  will remain unchanged in the application of the OoB mask

<sup>2</sup> OoB domain emission limits apply to unwanted emissions (both OoB and spurious emissions) in the OoB domain.

but the mask should be truncated. Accordingly, the OoB mask will only be applicable from 50% of  $B_N$  to  $(150 + 100 B_U/B_N)\%$  of  $B_N$ ;

## 6 Measurement methods

that the methods for measurement of OoB described in detail in Annex 13 should be used.

# Annex 1

## Methods to determine conformance to OoB domain emission limits

Two possible methods can be used to quantify the OoB emission energy. Section 1 provides a method by which the power is measured in an adjacent channel. Section 2 discusses a method of assessment based on the determination of the power spectral density in the OoB domain.

### 1 Adjacent channel and alternate adjacent channel power method

This methodology is based on the concept defined in Recommendation ITU-R SM.328 – Spectra and bandwidth of emissions, § 1.12 and has become popular since the commercial availability of spectrum analysers with digital signal processing capability which can perform numerical integration within a specified bandwidth.

A limit for permissible OoB domain power can be derived from the limits imposed by a permissible OoB spectrum mask by integrating the mathematical expression for the curve over a specified frequency band. An example of this translation is provided in Appendix 1 for an example emission mask used in the land mobile service, the primary user of this method. Comparisons of limits so derived with actual limits adopted in mobile service standards reveal that mobile radio industry practice has been to establish limits significantly more stringent than those derived from an OoB mask in order to achieve spectrum efficiency.

One key advantage of this method in a defined bandwidth approach is that the same approach is defined in Recommendation ITU-R SM.329 for limits of the power of spurious domain emissions displaced relatively far in the frequency spectrum from a transmitter's assigned frequency band (i.e. channel).

Another advantage is that it tends to facilitate frequency management if the reference bandwidth is chosen comparable to that of receivers used in the assigned frequency bands adjacent to that of a transmitter as this leads to more efficient use of the electromagnetic spectrum. This can be especially significant in new channel splitting "refarming" environments wherein the close packing of channels in an allocated band has resulted in frequency assignment coordination based on adjacent channel considerations in addition to co-channel considerations. It also provides a convenient means of assessing the interference potential between two different modulation methods used on adjacent channels or bands. This has proved useful in spectrum allocation planning in various countries to determine compatible neighbouring technologies and link directions.

#### 1.1 Parameters to be measured

The parameters to be measured are the occupied bandwidth of an emission, and the mean power in several defined bands. The same modulation condition is employed for all measurement bands.

The maximum value of 99% power occupied bandwidth permitted by a particular emission mask can be determined by calculating the frequency difference between the 23 dB attenuation levels for any emission mask.

## 1.2 Units of measurement

The units of power measurement are the same as those used for measurement of spurious domain emissions, as given in Annex 1 of Recommendation ITU-R SM.329 (mean power is specified for most measurements). Appropriate conversion factors (discussed in more detail in § 1.1.1 and § 1.1.2 of Annex 13) must be used to correct for differences between:

- the detection method employed in the signal analyser used to perform a measurement and the detection method specified for the limits; as well as
- the resolution bandwidth of the filter contained in the signal analyser used to perform a measurement and the detection method specified for the limits.

## 1.3 Measurement bands

Figure 3 graphically portrays the succeeding band descriptions.

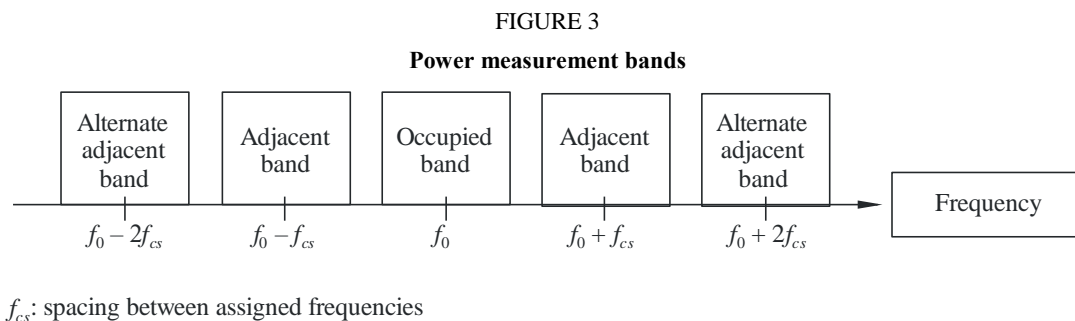

SM.1541-03

### 1.3.1 Adjacent band

The band properties follow, which provide several means for assessment of the amount of interference power that might be intercepted by a receiver on the adjacent channel. The power in this band is termed the adjacent band power (ABP).

#### 1.3.1.1 Location of the adjacent band

This band is centred on the adjacent assigned frequency band in the allocated band in which the transmitter operates.

For worst-case considerations, this band is located closer to the transmitter by an amount equal to that of the permissible frequency drift of the transmitter, plus any Doppler frequency difference.

#### 1.3.1.2 Bandwidth of the adjacent band

Its width is equal to the equivalent noise bandwidth of the adjacent channel receiver. If not known then the default value should be equal to the transmitter's occupied bandwidth.

### 1.3.2 Alternate adjacent band

This band is centred relative to the adjacent band in the same manner in which the adjacent band is centred relative to the assigned frequency band. Its width equals that of the adjacent band.

In some services (e.g. FM broadcast) channels are assigned by alternating two interlaced sets of assigned frequency band plans so this provides an assessment of the amount of interference power that might be intercepted by a receiver on the adjacent authorized channel. The power in this band is termed the alternate ABP.

For worst-case considerations, the centre of this band is located closer to the transmitter by an amount equal to that of the permissible frequency drift of the transmitter, plus that of a typical receiver used on the adjacent channel, plus any Doppler frequency difference.

#### 1.4 Adjacent band power ratio (ABPR)

ABPR is calculated in the following manner:

- in power, as  $ABPR = P/P_{ad}$
- in decibels, as  $ABPR = P - P_{ad}$  (dB)

where:

$P$ : transmitter mean power

$P_{ad}$ : mean power in the adjacent frequency band.

This calculation is performed as a routine operation automatically on many modern spectrum analysers equipped with digital signal processing capabilities.

The concept of measuring the power in the bandwidth of an adjacent channel can be extended to neighbouring bands in an allocated band which are  $N$  times further displaced than the adjacent band, where  $N$  is an integer multiple of the assigned frequency band. The designation  $ABPR_N$  should be used to denote the power of the OoB emission in the  $N$ -th adjacent channel.

## 2 OoB mask method

This methodology is based on the concept defined in Recommendation ITU-R SM.328 § 1.10.

### 2.1 Parameters to be measured

The transmitter spectrum should be measured using a measurement bandwidth in line with *recommends* 1.7 and should be characterized in terms of dBsd, dBc or dBpp.

### 2.2 Measurement range

Measurements are to be conducted in the OoB domain which is between the assigned frequency band boundary and the boundary between the OoB and spurious domains.

### 2.3 OoB mask

In accordance with Note 1 of § 1.10 of Recommendation ITU-R SM.328, the mask does not limit emissions within the necessary bandwidth as it is applicable in the OoB domain of the spectrum.

NOTE 1 – Within the OoB domain, there may be line spectra present at levels higher than the OoB mask. A mask which allows for these individual spectra might not be stringent enough. Therefore an approach may need to be considered for some emissions which allows for a limited number of such spectra at given levels above the mask; those specific limits, when necessary, are specified in the relevant Annexes dealing with specific radiocommunication services.

## Appendix 1 to Annex 1

### Example calculation of a permissible OoB power ratio and power limits from a permissible OoB mask

#### 1 Introduction

Integration of an OoB mask over a specific frequency range permits calculation of the maximum permitted OoB domain power in that band permitted by that mask and serves to relate the two methods used for limiting OoB domain emissions. This relationship may be calculated using either a discrete method or a continuous method. The former method emulates the manner in which a spectrum analyser or a vector signal analyser with digital power measurement capability functions while the latter provides a purely mathematical approach. Due to advances in digital technology this capability is now available in many commercially available spectrum analyser families. Both methods are valid and lead to the same resultant within negligible difference as will be demonstrated in the following examples.

The examples will utilize the digital emission mask formula described in Table 3 used in many countries, sometimes referred to as emission mask G. This example calculates the total power in an adjacent band of 25 kHz width. Simple adjustment of the integration range limits permit calculation for other bandwidths.

TABLE 3

**Attenuation equations for emission mask G**  
(used in some countries for non-voice transmitters used with 25 kHz  
channel spacing (based on RBW = 300 Hz))

Frequency range	Attenuation limits (dB)
$5 \text{ kHz} <  fd  < 10 \text{ kHz}$	$83 \log (fd/5)$
$10 \text{ kHz} <  fd  < 2.5 \times \text{ABW}$	The lesser of $116 \log (fd/6.1)$ dB, or $50 + 10 \log (P)$ dB, or 70 dB

ABW: authorized bandwidth (larger of either occupied bandwidth or necessary bandwidth).

$fd$ : displacement frequency from carrier frequency (kHz).

RBW: reference bandwidth in which the power of the OoB domain emissions is specified.

Discontinuities in the mask formula (i.e. breakpoints) of  $P = 1 \text{ W}$  transmitter occur, as evident in Table 4 and Fig. 4, necessitating integration over multiple ranges.

TABLE 4

**Breakpoints in OoB mask G**  
(based on RBW = 300 Hz)

Frequency displacement from carrier (kHz)	Attenuation (dB)
12.5	36.14
16.46	50

The G mask is graphically portrayed in Fig. 4.

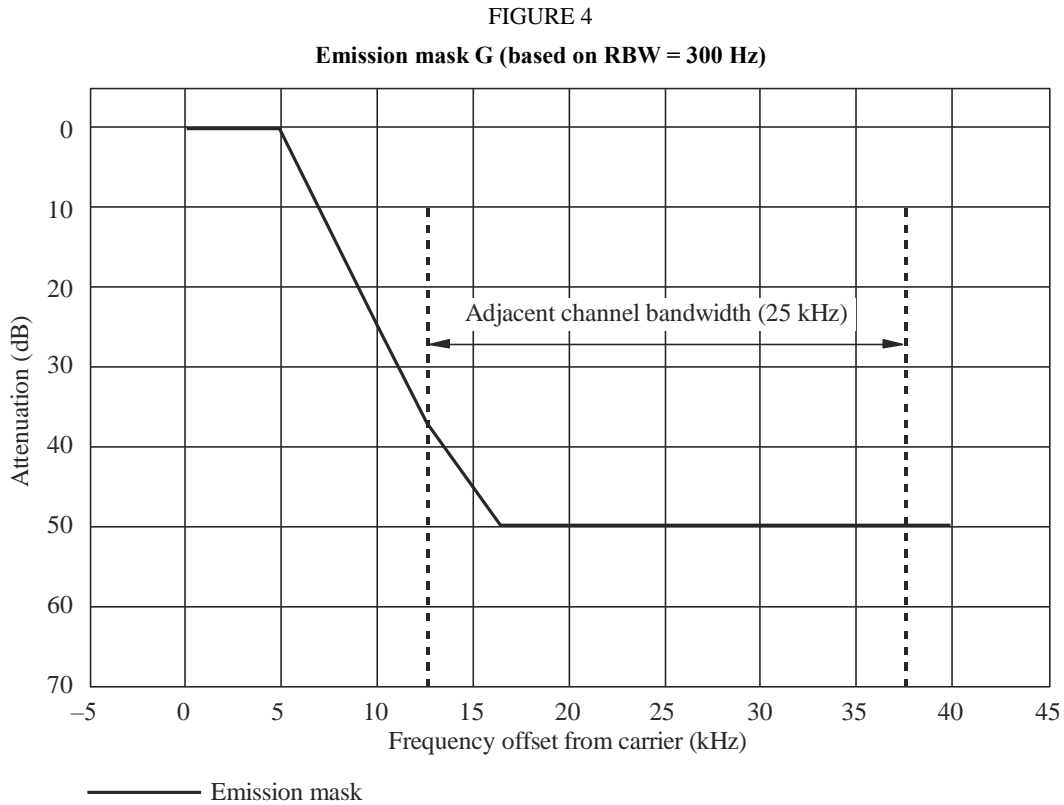

SM1541-04

## 2 Discrete method

This example is for a 1 W transmitter and notation follows that is used in a software program to calculate the results. This mask has a transition in the midst of the adjacent frequency band, and 2 breakpoint frequency displacements from the centre of the emission need to be determined. First is a transmitter power level dependent frequency breakpoint at which attenuation reaches  $50 + 10 \log (P)$  dB, where  $P$  is the transmitter power (W). Second is the breakpoint at which attenuation equals 70 dB. For the side of the adjacent band which is nearest the emission, the power level independent attenuation formula for the example power spectral density attenuation mask is given in equation (1), while equation (11) contains the power level dependent formula for the frequency range on the far side of the appropriate breakpoint frequency. Power in both regions must be summed to determine the total adjacent band power.

In the following equations the notation “:=” means “defined as” and “[ ]”, when used in mathematical equations, are not temporary but agreed text.

The near side attenuation equation is represented in this Appendix by:

$$AN(fd) := 116 \log (fd / 6.1) \quad \text{dB} \quad (1)$$

where  $fd$  is the frequency displacement (kHz) from the centre of the emission.

To determine the adjacent band power it is necessary to convert this logarithmic representation of the permissible emission spectral power density limit to a linear representation, so the attenuation can be integrated or summed over the frequency range of the adjacent band, using:

$$an(fd) := 10^{-AN(fd)/10} \quad (2)$$

To determine the power limited by the mask, the attenuation must be summed at equal intervals equal to the resolution bandwidth specified for emission mask measurements (i.e. numerical integration) over the frequency band being assessed. For this mask:

$$RBW := 0.3 \quad \text{kHz} \quad (3)$$

and the adjacent band is assigned a bandwidth of 25 kHz. The adjacent band is centred at a displacement of 25 kHz, thus the adjacent assigned band starts at a frequency displacement of  $25 - 25/2 = 12.5$  kHz and ends at 37.5 kHz. However, an adjustment equal to half the bandwidth of the resolution filter bandwidth is needed to preclude inclusion of energy outside the adjacent band, so power summation needs to begin at  $12.5 + 0.3/2 = 12.65$  kHz. The power level dependent breakpoint frequency,  $fb$ , is given by rearranging equation (1) to be:

$$fb := 6.1 \times 10^{\left[\frac{50 + 10 \log(P)}{116}\right]} \quad (4)$$

For a  $P = 1$  W transmitter the 50 dB breakpoint lies at 16.46 kHz. The 70 dB breakpoint, which applies as well to all transmitters of 100 W or more power, occurs at 24.48 kHz.

The power attenuation in the near side region of the adjacent band may then be determined by summing over the frequency displacement range 12.65 kHz to 16.46 kHz which, after adjustment, is represented by:

$$fd := 12.65, 12.95, \dots, 16.31 \quad \text{kHz} \quad (5)$$

The near side portion of the emission mask in the adjacent band logarithmically appears in Fig. 5:

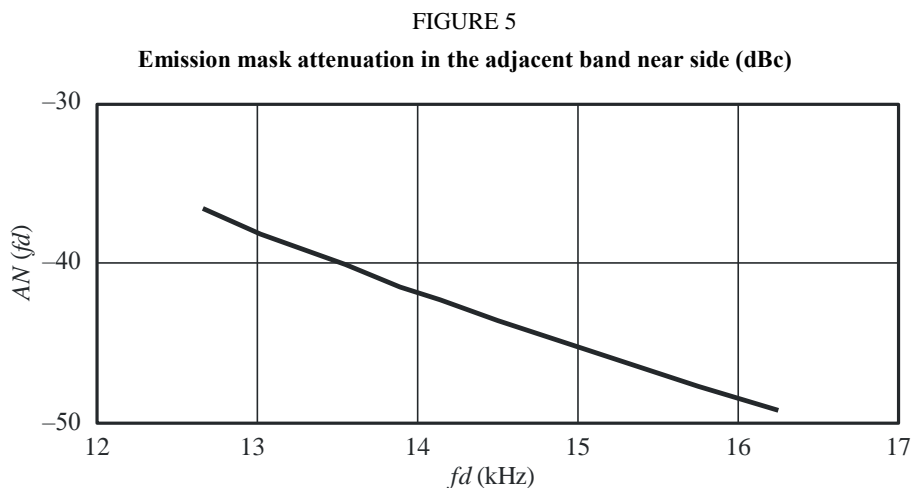



and the linear representation for this mask follows in Fig. 6.

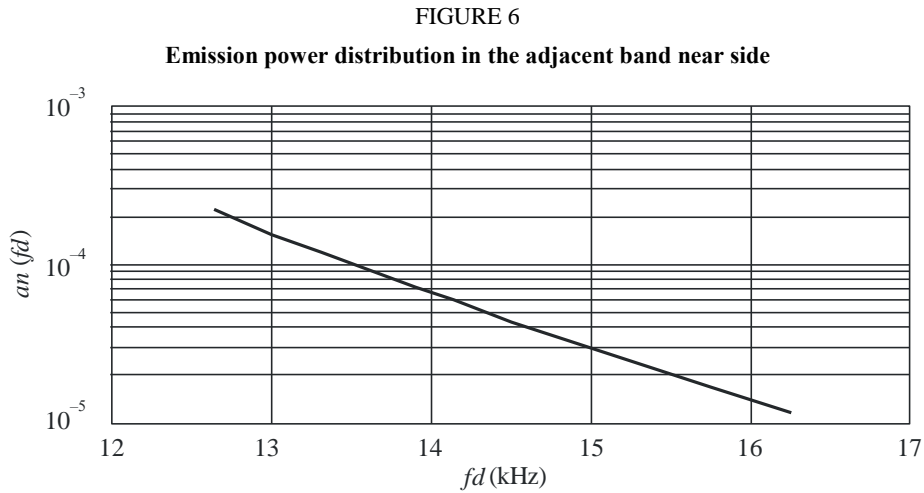

SM1541-06

The total adjacent band power relative to the total emission power is a ratio which is determined by summing the power in the adjacent band bandwidth shown in Fig. 6 using the following equation:

$$abprn := \sum_{fd} an(fd) \tag{6}$$

This equates to:

$$abprn = 8.99 \times 10^{-4} \tag{7}$$

This can be converted back to attenuation for the adjacent band power limit (dB) using:

$$ABPRN := 10 \log(abprn) \tag{8}$$

which evaluates as:

$$ABPRN = -30.46 \quad \text{dB} \tag{9}$$

The formula for the example psd attenuation mask in the far side region of the adjacent frequency band for a 1 W radio is:

$$AF(fd) := 50 + 10 \log(1) \quad \text{dB} \tag{10}$$

where *fd* is the frequency displacement in kHz from the centre of the emission.

To determine the adjacent band power it is necessary to convert this logarithmic representation of the emission psd to a linear representation, so the power can be integrated or summed over the frequency range of the adjacent band, using:

$$af(fd) := 10^{\frac{-AF(fd)}{10}} \tag{11}$$

To determine the power limited by the mask the power must be summed at equal intervals equal to the resolution bandwidth specified for emission mask measurements (i.e. numerical integration) over the frequency band being assessed. For this mask:

$$RBW := 0.3 \quad \text{kHz} \quad (12)$$

The adjacent band power limit relative to the total emission power may then be calculated by summing the attenuation over the range 16.46 kHz to 37.5 kHz which, after adjustment, is represented in this Appendix by:

$$fd := 16.61, 16.91, \dots, 37.35 \quad \text{kHz} \quad (13)$$

The far side of the emission mask in the adjacent band logarithmically appears in Fig. 7.

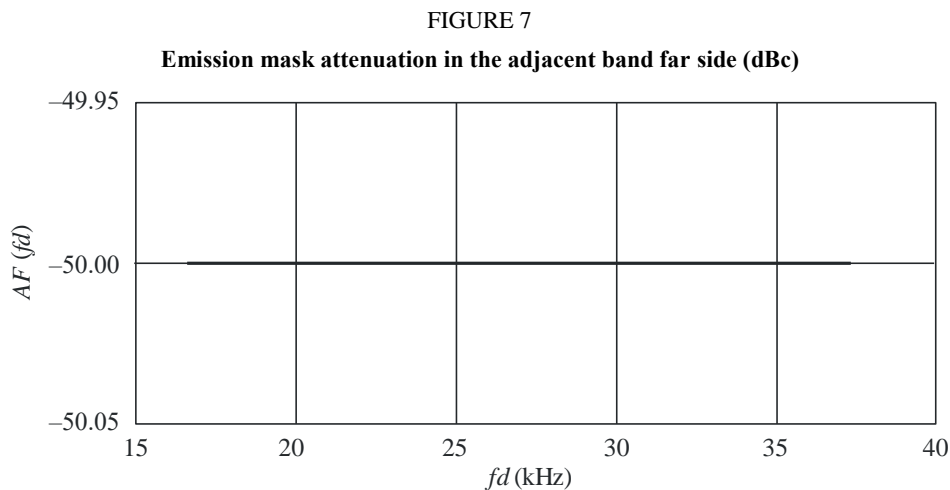

SM.1541-07

The total ABP relative to the total emission power is a ratio which is determined by summing the power in the adjacent band bandwidth using the following formulation:

$$abprf := \sum_{fd} af(fd) \quad (14)$$

This equates to:

$$abprf = 7 \times 10^{-4} \quad (15)$$

and evaluates as:

$$ABPRF = -31.55 \quad \text{dB} \quad (16)$$

The total power is the sum of those in equations (6) and (14):

$$abpr = abprn + abprf \quad (17)$$

which evaluates to:

$$abpr = 15.99 \times 10^{-4} \quad (18)$$

This translates to:

$$ABPR := -10 \log (abpr) \quad \text{dB} \quad (19)$$

which evaluates as:

$$ABPR = 27.96 \quad \text{dB} \quad (20)$$

This attenuation establishes  $ABPR_1 = +30 \text{ dBm} - 27.96 \text{ dB}$ , i.e. 2.04 dBm.

### 3 Continuous method

In general, the emission mask curves have several line segments and the power spectral density can be represented by a linear equation on each segment.

$$S_{\text{dB}}(f) = af + b \quad (21)$$

To calculate the unwanted power levels injected into the adjacent band, it is needed to relate spectra measured with 300 Hz bandwidth, denoted by  $G$ , to the true power spectral density, denoted by  $S$ . If we assume that power levels of  $G$  are also represented by a linear equation  $G = a'f + b'$ , the problem is to relate the linear line coefficients  $a'$  and  $b'$  of the  $G$  function behaviour to the  $S$  function coefficients  $a$  and  $b$ . The relationship between  $G(f_c)$  and  $S(f_c)$  can be represented as follows:

$$\begin{aligned} G(f_c) &= \int_{f_c-B/2}^{f_c+B/2} S(f) df \\ &= \int_{f_c-B/2}^{f_c+B/2} 10^{[S_{\text{dB}}(f)/10]} df = \int_{f_c-B/2}^{f_c+B/2} 10^{[(af+b)/10]} df = \int_{f_c-B/2}^{f_c+B/2} e^{\ln 10[(af+b)/10]} df \\ &= \int_{f_c-B/2}^{f_c+B/2} \exp(k(af+b)) df = \frac{1}{ka} e_{kb} [e_{kaf}]_{f_c-B/2}^{f_c+B/2} \\ &= \exp(k(af_c+b)) \frac{\sinh(\alpha B)}{\alpha} \end{aligned} \quad (22)$$

where  $k = \ln(10)/10$ ,  $\alpha = ka/2$  and  $f_c$  is the centre frequency of resolution bandwidth  $B$ . Also the measured power spectral density in decibels based on resolution bandwidth is calculated by equation (23) and equating the coefficients yields (24) and (25).

$$G_{\text{dB}}(f_c) = 10 \log(G(f_c)) = \frac{1}{k} \ln(G(f_c)) = a'f_c + b' \quad (23)$$

$$a = a' \quad (24)$$

$$b = b' - \frac{1}{k} \ln\left(\frac{\sinh(\alpha B)}{\alpha}\right) \quad (25)$$

If  $a'$  approaches zero, the equation for  $b$  becomes:

$$b = b' - \frac{1}{k} \ln(B) \quad (26)$$

To calculate the permissible OoB domain power using the above procedure, one must first derive the equation  $S_{dB}(f) = af + b$  and integrate this equation over the adjacent channel bandwidth.

$$\text{Permissible out-of-band domain power} = \int_W 10^{[S_{dB}(f)/10]} df$$

where  $W$  is the adjacent channel bandwidth.

Using transmitter power  $P$  equal to 1 W in a 25 kHz band system, based on a resolution bandwidth of 300 Hz the emission mask appears as shown in Fig. 5. Also, the breakpoint reference levels of emission mask are given in Table 4 so the calculation interval can be divided into two sub intervals adjacent channel bandwidth according to the emission curve shape, that is, (12.5 kHz-16.46 kHz) and (16.46 kHz-37.5 kHz). From Table 3, we can get a linear function equation (27) based on Table 4 breakpoints (12.5 kHz, -36.14 dB) and (16.46 kHz, -50 dB). And also, in the frequency range larger than 16.46 kHz, a constant level of -50 dB results as given by equation (28).

$$\text{For } 12.5 \text{ kHz} \leq f \leq 16.46 \text{ kHz} \quad G_{dB}(f) = 7.61 - 3.5 f \quad (27)$$

$$\text{For } 12.46 \text{ kHz} \leq f \leq 37.5 \text{ kHz} \quad G_{dB}(f) = -50 \quad (28)$$

Equations (27) and (28) can be converted to the following equations using (24), (25) and (26).

$$\text{For } 12.5 \text{ kHz} \leq f \leq 16.46 \text{ kHz} \quad S_{dB}(f) = 12.84 - 3.5 f \quad (29)$$

$$\text{For } 12.46 \text{ kHz} \leq f \leq 37.5 \text{ kHz} \quad S_{dB}(f) = -44.77 \quad (30)$$

The total power levels in adjacent channel bandwidth are the summation of two integration results over respective sub intervals.

Permissible OoB emission attenuation:

$$\begin{aligned} &= \int_{12.5}^{16.46} 10^{[(12.84-3.5f)/10]} df + \int_{16.46}^{37.5} 10^{[-44.77/10]} df \\ &= 0.00095 + 0.0007 = 0.00165 \end{aligned} \quad (31)$$

In decibels, the above attenuation requirement is converted as follows:

$$10 \log(0.00165) = -27.8 \quad \text{dB} \quad (32)$$

This attenuation establishes  $ABP_1 = +30 \text{ dBm} - 27.8 \text{ dB}$ , i.e. 2.2 dBm, a result very close to that obtained using the discrete method.

## Annex 2

### Calculation of the start and end of the OoB domain for multicarrier systems with single and multiple transponders per satellite

This annex provides two examples showing how to calculate the start and end of the OoB domain for multicarrier systems with single and multiple transponders per satellite.

#### 1 Example 1: Multiple transponders per satellite serving the same service area

Figure 8 is one example of a satellite with multiple transponders. In this example, the width of the band in which the satellite is licensed or authorized to transmit is 20 MHz, the 3 dB bandwidth of the transponder is 5 MHz, and the necessary bandwidth of a single carrier emission is 1 MHz.

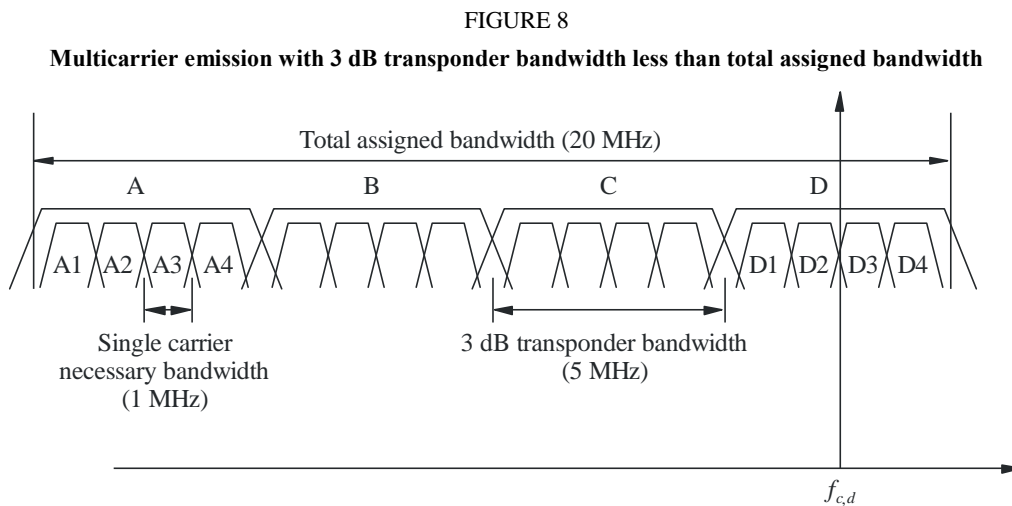

SM.1541-08

This Recommendation equates necessary bandwidth,  $B_N$ , of a multicarrier emission to the lesser of the  $-3$  dB bandwidth of the transponder and of total assigned bandwidth. Hence, for the example above, the necessary bandwidth would be 5 MHz. The OoB domain begins at the edges of each total assigned bandwidth that is part of the band over which the system is authorized.

The OoB domain is taken to be those frequencies that are separated from the centre frequency by more than 50% of the necessary bandwidth and less than 250% of the necessary bandwidth (the bandwidth of transponders A and D). Consequently, the width of the OoB domain is 200% of the necessary bandwidth. So for the example shown in Fig. 9, the width of OoB domain above  $f_{AU}$  and below  $f_{AL}$  is 10 MHz. The OoB and spurious domains are shown in Fig. 9.

FIGURE 9

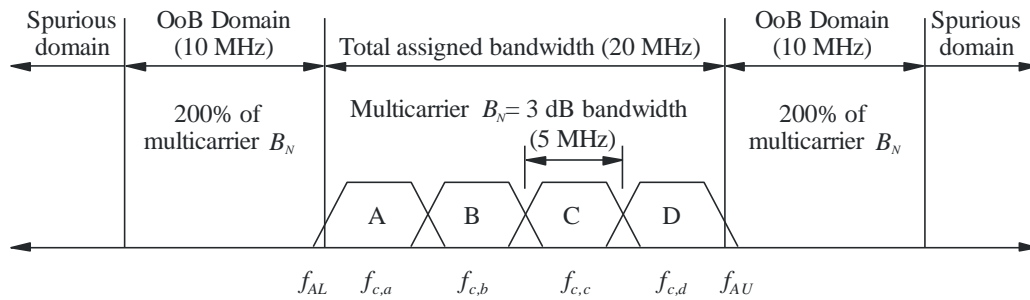
**OoB and spurious emission domains for multicarrier system shown in Fig. 8**

SM1541-09

**2 Example 2: Single transponder per satellite**

When all carriers in Fig. 8, A1 through D4, are passed through a single transponder the OoB domain should start at the edges of the total assigned bandwidth and the width of the OoB domain should equal 200% of the necessary bandwidth where the necessary bandwidth is set to the minimum of the total assigned bandwidth and 3 dB transponder bandwidth.

**Annex 3****Graph labelling for dBc and dBsd masks**

This annex shows the way to label the axes of dBc and dBsd spectrum masks.

**1 Y-axis labelling of OoB masks**

Figure 10 shows the preferred way to label the Y-axis on dBc and dBsd spectrum masks, where negative relative level values are used. Figure 11 shows an alternate way using positive attenuation values. Note that the masks for symmetric limits are drawn the same in Figs 10 and 11; only the labelling of the Y-axis is different. For dBsd graphs, the reference bandwidth should be included in the label, e.g. dBsd (BW = 50 kHz).

The convention of having zero at the top of the Y-axis follows the usual industry practice for specifying limit masks and displaying spectra on spectrum analysers and other test equipment.

FIGURE 10

Examples of preferred Y-axis labelling of symmetric OoB masks, using relative levels

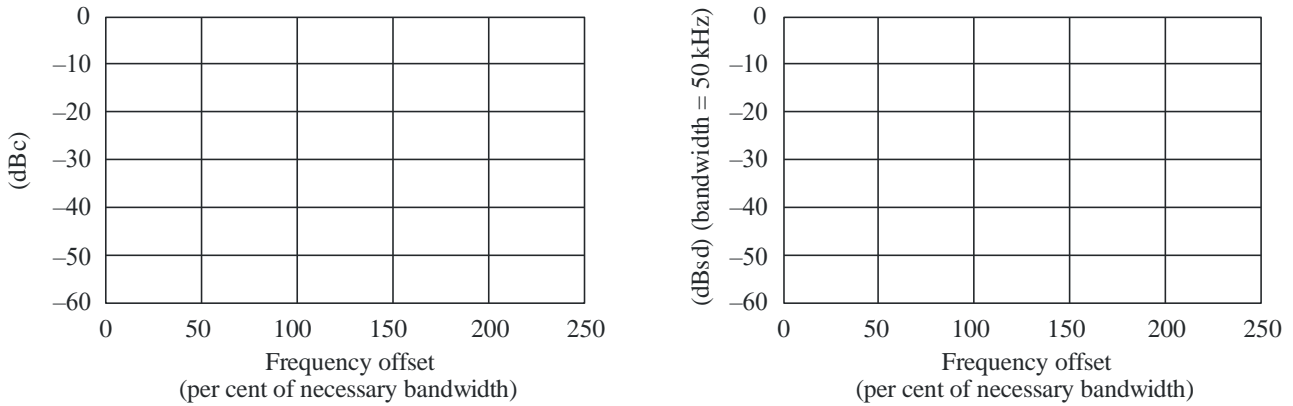

SM1541-10

FIGURE 11

Examples of alternate Y-axis labelling of symmetric OoB masks, using attenuation levels

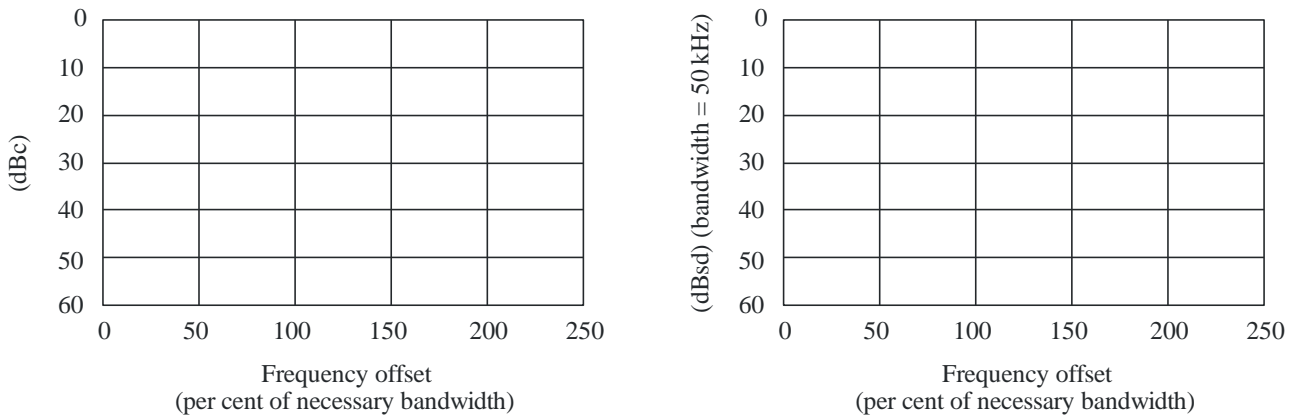

SM1541-11

## 2 X-axis labelling of OoB masks

The frequency offset is usually given as the per cent of necessary bandwidth, but sometimes it may be more convenient to give it as a per cent of channel bandwidth. The frequency offset may also be given in absolute units of kHz or MHz.

Usually, the mask limits are symmetric about the centre frequency, and only positive frequency offset values are shown; which are interpreted to be absolute values that represent both positive and negative frequency offsets. In this case, only the positive frequency offset values are shown. However, for limits that are asymmetric about the centre frequency, the X-axis needs to include both positive and negative frequency offsets. Figure 12 shows an example graph that can be used for either asymmetric or symmetric limits.

FIGURE 12

Example of graph labelling of asymmetric or symmetric OoB masks

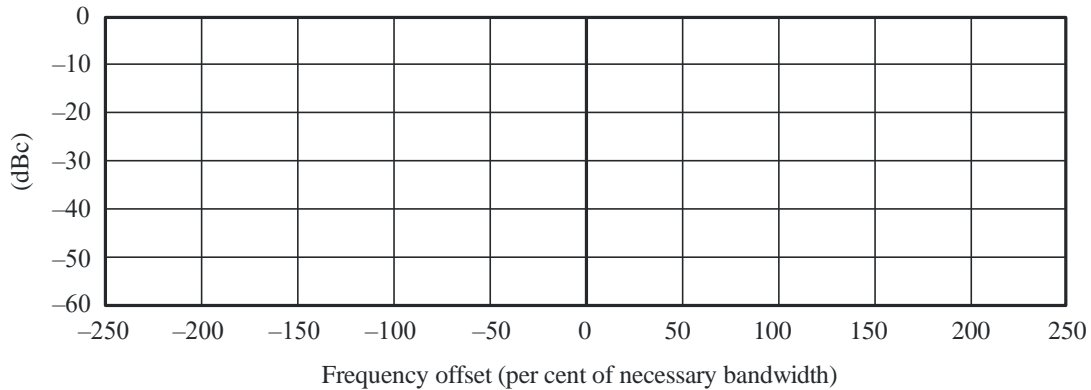

SM1541-12

## Annex 4

### List of ITU-R texts concerning OoB domain emissions related to specific services

Recommendation ITU-R F.1191 – Necessary and occupied bandwidths and unwanted emissions of digital fixed service systems

Recommendation ITU-R M.478 – Technical characteristics of equipment and principles governing the allocation of frequency channels between 25 and 3 000 MHz for the FM land mobile service

Recommendation ITU-R M.1580 – Generic unwanted emission characteristics of base stations using the terrestrial radio interfaces of IMT-2000

Recommendation ITU-R M.1581 – Generic unwanted emission characteristics of mobile stations using the terrestrial radio interfaces of IMT-2000

Report ITU-R M.2014 – Digital land mobile systems for dispatch traffic

Recommendation ITU-R BS.1114 – Systems for terrestrial digital sound broadcasting to vehicular, portable and fixed receivers in the frequency range 30-3 000 MHz

Recommendation ITU-R BT.1206 – Spectrum limit masks for digital terrestrial television broadcasting

Recommendation ITU-R M.1480 – Essential technical requirements of mobile earth stations of geostationary mobile-satellite systems that are implementing the global mobile personal communications by satellite (GMPCS) – Memorandum of understanding arrangements in parts of the frequency bands 1-3 GHz

Recommendation ITU-R M.1343 – Essential technical requirements of mobile earth stations for global non-geostationary mobile-satellite service systems in the bands 1-3 GHz

NOTE 1 – Recommendation ITU-R M.1343 could be applied also to terminals in regional non-geostationary satellite systems, although the title refers to global systems.



**Annex 5**

**OoB domain emission limits for space services (earth and space stations)**

**1 Introduction**

In certain cases, it has been deemed that the OoB masks (of sections 2 through 4) should not apply. For the case of a single satellite operating with more than one transponder in the same service area, and when considering the limits for OoB emissions described below, OoB emissions from one transponder may fall on a frequency at which a second companion transponder is transmitting. In these situations, the level of OoB emissions from the first transponder is well exceeded by fundamental emissions of the second transponder. Therefore, the limits below should not be applied to those OoB emissions of a satellite which fall within the necessary bandwidth of another transponder, on the same satellite, into the same service area.

FIGURE 13  
**Example of applicability of OoB limits to a satellite transponder**  
 (this Figure is not drawn to scale)

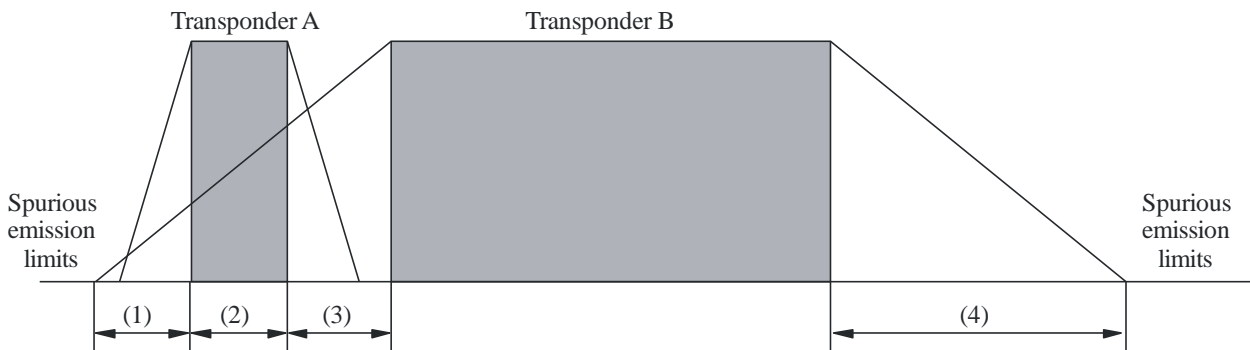

SM.1541-13

Transponders A and B are operating on the same satellite in the same service area. Transponder B is not required to meet OoB domain emission limits in frequency range 2 but is required to meet them in frequency ranges 1, 3 and 4. In frequency range 3, OoB domain emission limits do not apply if it is a guardband.

**2 OoB masks for fixed-satellite service (FSS) earth and space stations**

The OoB domain emissions of a station operating in the bands allocated to the FSS should be attenuated below the maximum psd, in a reference bandwidth of 4 kHz (for systems operating above 15 GHz a reference bandwidth of 1 MHz may be used in place of 4 kHz) within the necessary bandwidth, by the following:

$$40 \log \left( \frac{F}{50} + 1 \right) \quad \text{dBsd}$$

where  $F$  is the frequency offset from the edge of the total assigned band, expressed as a percentage of necessary bandwidth. It is noted that the OoB emission domain starts at the edges of the total assigned band.

FIGURE 14

**Example 1: OoB mask assuming the spurious limit is equivalent to 25 dBsd**  
 (attenuation no greater than the spurious limit)

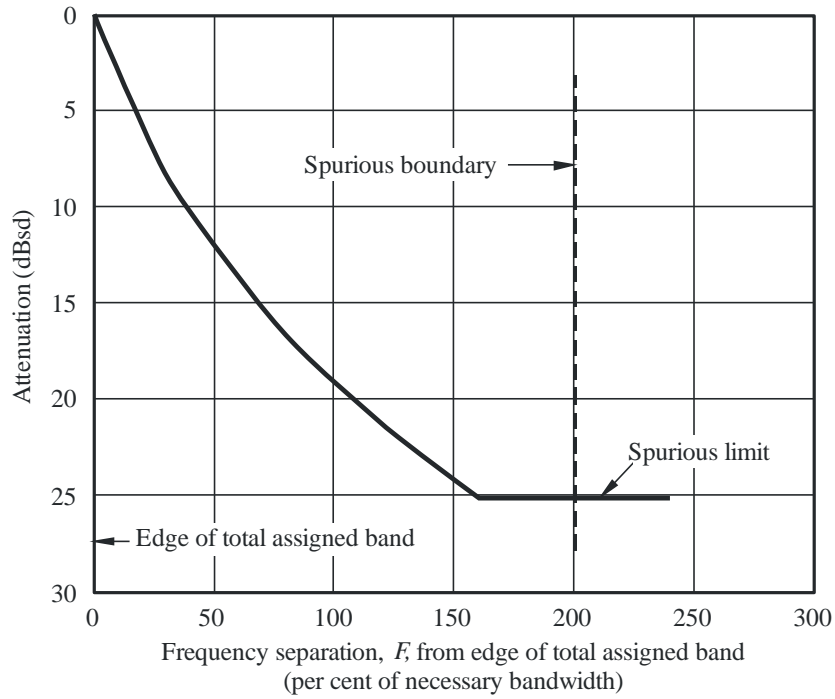

SM1541-14

FIGURE 15

**Example 2: OoB mask assuming the spurious limit is equivalent to 40 dBsd**  
 (mask truncated at the spurious boundary)

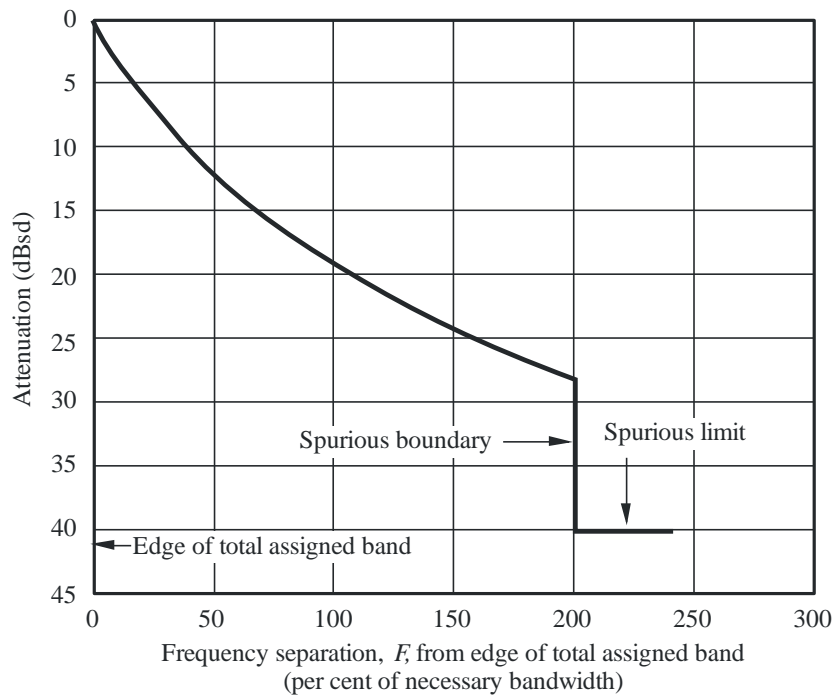

SM1541-15

Care should be taken in cases where OoB masks have been proposed to apply to both earth stations and space stations. This is because, for multicarrier applications, the necessary bandwidth, upon which the masks are based, is defined to be that of the final amplifier of the transmitter. Earth stations often have amplifiers with much wider bandwidth than those of space stations.

### 3 OoB masks for mobile-satellite service (MSS) earth and space stations

The masks contained in Recommendation ITU-R M.1480 can be used for mobile earth stations of geostationary-satellite orbit (GSO) MSS systems implementing the GMPCS memorandum of understanding in parts of the frequency band 1-3 GHz.

The masks contained in Recommendation ITU-R M.1343, representing non-GSO mobile earth stations in the band 1-3 GHz can form one input for the mobile earth station data.

For earth stations not covered in the above-mentioned Recommendations and for all space stations, the following generic OoB mask, considered as an upper bound for MSS systems, is to be used:

Attenuation of OoB emissions in the reference bandwidth of 4 kHz for MSS systems below 15 GHz (otherwise in reference bandwidth of 1 MHz for MSS systems above 15 GHz) is:

$$40 \log \left( \frac{F}{50} + 1 \right) \quad \text{dBsd}$$

where  $F$  is the frequency offset from the edge of the total assigned band, expressed as a percentage of necessary bandwidth, which will range from 0% to the spurious boundary (which is usually 200%).

The above-proposed mask may not be applicable in detailed examination of adjacent band compatibility.

### 4 OoB masks for broadcasting-satellite service (BSS) space stations

The OoB emissions of a station operating in the bands allocated to the broadcasting-satellite service should be attenuated below the maximum power spectral density, in a reference bandwidth of 4 kHz (for systems operating above 15 GHz a reference bandwidth of 1 MHz may be used in place of 4 kHz), within the necessary bandwidth, by the following:

$$32 \log \left( \frac{F}{50} + 1 \right) \quad \text{dBsd}$$

where  $F$  is the frequency offset from the edge of the total assigned band, expressed as a percentage of necessary bandwidth. It is noted that the OoB domain starts at the edges of the total assigned band.

## 5 OoB mask for the space research service (SRS), space operations service (SOS), and Earth exploration-satellite service (EESS) telecommunication space-to-Earth links operating in the 1-20 GHz band

### 5.1 Introduction

This Annex provides an OoB mask for the SRS, SOS, and EESS space-ground links operating in the 1-20 GHz bands. The mask is not applicable to deep space stations, active sensors, or space-to-space links.

## 5.2 OoB masks for SRS, SOS and EESS systems operating in the space-to-Earth and Earth-to-space directions

The mask shown in Fig. 16 applies to single carrier emissions from SRS, SOS, and EESS earth stations and space stations operating at centre frequencies between 1 GHz and 20 GHz.

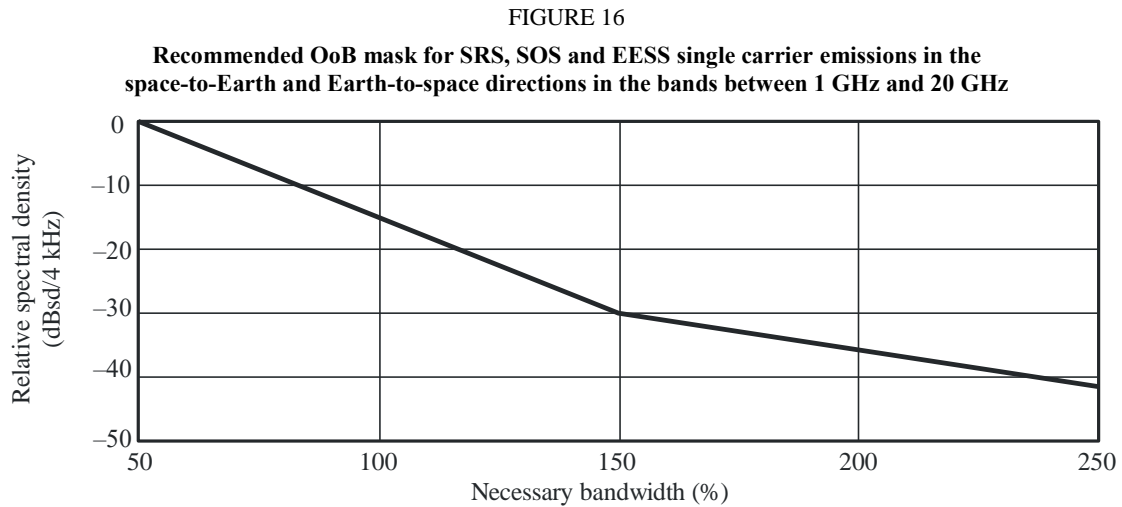

*Note 1* – The emission mask generally extends to 250% of the necessary bandwidth. However, the outer edge of the OoB domain for narrow-band and wideband systems is modified as indicated in Recommendation ITU-R SM.1539.

SM1541-16

### 5.2.1 Emission mask parameters

The emission mask is specified in dBsd units measured in a 4 kHz reference bandwidth.

The emission mask is defined to be:

$$\text{Attenuation} = -15 + 15 (X / 50\%) \quad \text{dBsd} \quad \text{for } 50\% < X \leq 150\% \quad (33)$$

$$\text{Attenuation} = +12 + 6 (X / 50\%) \quad \text{dBsd} \quad \text{for } 150\% < X \leq 250\% \quad (34)$$

where  $X$  is specified as a percentage of the necessary bandwidth.

### 5.2.2 Emission mask applicability

The emission mask herein is only applicable to single-carrier emissions in the space research, space operation and Earth exploration-satellite stations in bands between 1 GHz and 20 GHz. It does not apply to emissions of deep space stations, stations operating space-to-space links (SSLs), or active sensors. Emission masks for SSLs and space-to-ground links below 1 GHz and above 20 GHz require further study.

### 5.2.3 Basis for the emission masks

The emission mask given by equations (33) and (34) was selected because simulations show that the emission mask can be met without unnecessarily constraining SRS, SOS and EESS ground stations and spacecraft. Furthermore, it generally provides sufficient protection against unwanted emissions. Further, the mask is consistent with the safety net concept, i.e. that the general OoB recommended limits will generally be a worst-case envelope based on least restrictive OoB emission limits successfully used as national or regional regulations and they will not include more stringent regional or national limits.

## 6 Standard frequency and time signals (SFTS) services

### 6.1 SFTS services operating below 30 MHz

#### Band 7 (2.5 to 25 MHz)

Emissions in band 7 from 2.5 to 25 MHz by the SFTS service typically include time-division multiplexing of voice announcements, tone bursts and time codes. Each signal is impressed upon the carrier using double-sideband amplitude modulation.

The SFTS spectrum limit masks are calculated according to Recommendation ITU-R SM.328, § 6.3.3 of Annex 1, using the channel bandwidths given above, since sound broadcasting is the determining signal for necessary bandwidth.

If the frequency is plotted as the abscissa in logarithmic units and if the power densities are plotted as ordinates (dB) the curve representing the OoB spectrum should lie below two straight lines starting at point  $(+0.5 \times \text{channel bandwidth}, 0 \text{ dB})$  or at point  $(-0.5 \times \text{channel bandwidth}, 0 \text{ dB})$  and finishing at point  $(+0.7 \times \text{channel bandwidth}, -35 \text{ dB})$  or  $(-0.5 \times \text{channel bandwidth}, -35 \text{ dB})$  respectively. Beyond these points and down to the level of  $-60 \text{ dB}$ , this curve should lie below two straight lines starting from the latter points and having a slope of  $12 \text{ dB/octave}$ . Thereafter, the same curve should lie below the level  $-60 \text{ dB}$ .

The reference level,  $0 \text{ dB}$ , corresponds to the power density that would exist if the total power, excluding the power of the carrier, were distributed uniformly over the necessary bandwidth.

The ordinate of the curve so defined represents the average power intercepted by an analyser with an r.m.s. noise bandwidth of  $100 \text{ Hz}$ , the frequency of which is tuned to the frequency plotted on the abscissa.

## Annex 6

### OoB domain emission limits for television broadcasting systems

This Annex provides the OoB domain emission limits to be applied to broadcast television systems. According to the safety net principle (see *recommends* 4), it should be noted that more stringent limits are not affected in cases where special agreements for the broadcasting services for coordination and compatibility reasons exist. The more stringent limits specified in the relevant agreements and standards shall be used in all cases where a special need can be indicated and the scope of an agreement would be affected.

NOTE 1 – All the masks presented are overall emission masks inclusive of OoB domain emission limits.

### 1 Digital TV – 6 MHz channelling to Recommendation ITU-R BT.1306

#### 1.1 6 MHz DVB-T systems

For 6 MHz digital television, the OoB domain extends from  $\pm 3 \text{ MHz}$  (i.e.  $\pm 0.5 \times 6 \text{ MHz}$ ) to  $\pm 15 \text{ MHz}$  (i.e.  $\pm 2.5 \times 6 \text{ MHz}$ ).

For 6 MHz DVB-T, a  $4 \text{ kHz}$  measurement bandwidth is used to measure spectrum limits. The  $0 \text{ dB}$  reference level corresponds to the mean output power measured in the channel bandwidth.

Spectrum limit mask for 6 MHz DVB-T systems is shown in Fig. 17. The graph is drawn to represent the spectrum limits for transmitters in the output power range 39 dBW to 50 dBW. Associated with each graph is a table of break points and a table of end point and next-to-end point values, together with the corresponding spurious levels, for a range of transmitter output powers.

FIGURE 17

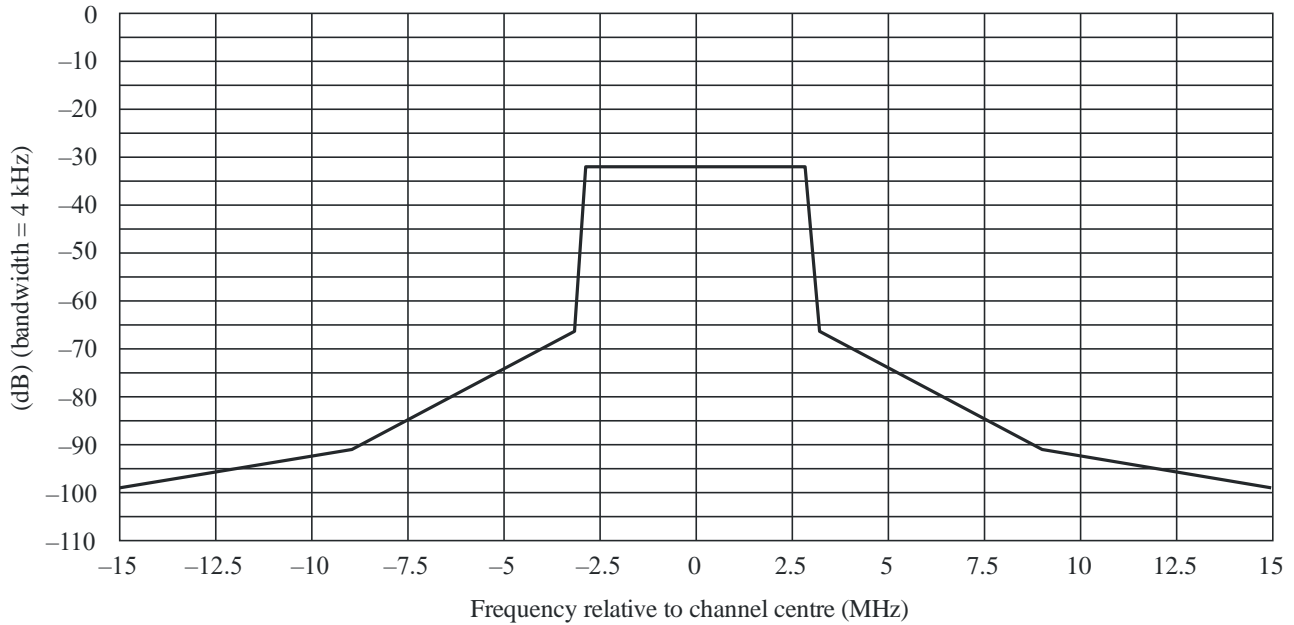
Spectrum limit mask for 6 MHz DVB-T (for  $P=39$  to 50 dBW)

SM1541-17

TABLE 5

Table of break points corresponding to Fig. 17 for 6 MHz DVB-T systems

Frequency relative to the centre of the 6 MHz channel (MHz)	Relative level in a 4 kHz measurement bandwidth (dB)
-15	-99
-9	-91
-3.2	-66.5
-2.86	-31.5
2.86	-31.5
3.2	-66.5
9	-91
15	-99

TABLE 6

Table of end point value and next-to-end point values to be used in conjunction with Fig. 17 and Table 5, applicable to a range of transmitter output powers, for 6 MHz DVB-T systems

End point value <sup>(1)</sup> (4 kHz measurement bandwidth) (dB)	Power range (dBW)	Corresponding spurious level (100 kHz measurement bandwidth)
$-89 - (P - 9)$	$P \leq 9$	-36 dBm
-89	$9 < P \leq 29$	75 dBc
$-89 - (P - 29)$	$29 < P \leq 39$	-16 dBm
-99	$39 < P \leq 50$	85 dBc
$-99 - (P - 50)$	$50 \leq P$	-5 dBm

(1) The next-to-end point value is 8 dB higher than the end point value and all of these values are subject to an upper limit equal to -66.5 dB.

**1.2 6 MHz channelling ISDB-T systems**

For 6 MHz ISDB-T systems, the OoB domain extends from ±3 MHz (i.e.  $\pm 0.5 \times 6$  MHz) to ±15 MHz (i.e.  $\pm 2.5 \times 6$  MHz) relative to channel centre.

Spectrum limit mask for a 6 MHz ISDB-T system is shown in Fig. 18. The related break points are given in Table 7. The relative power level is defined in a reference bandwidth of 4 kHz. The 0 dB reference level corresponds to the mean output power measured in the channel bandwidth. These emission limits apply when transmitter power is above 39 dBW.

FIGURE 18  
Spectrum limit mask for 6 MHz ISDB-T (for  $P > 39$  dBW)

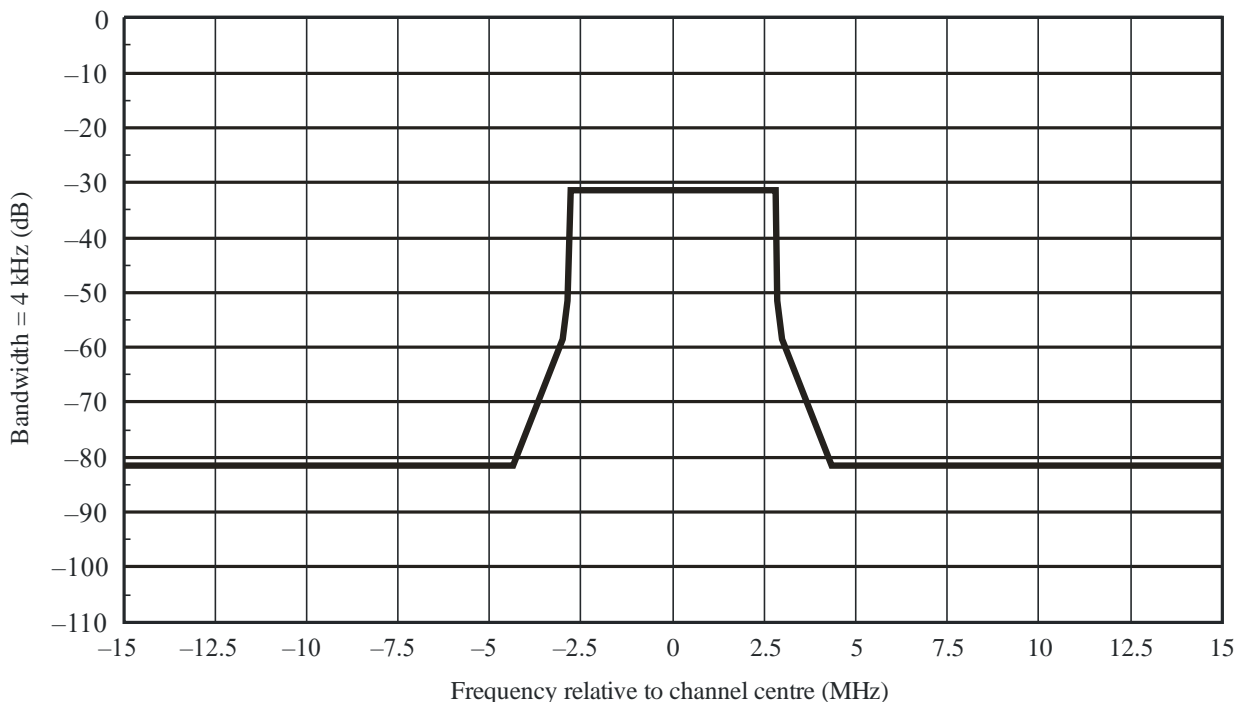

TABLE 7

## Break points for 6 MHz ISDB-T systems

Frequency relative to the centre of the 6 MHz channel	Relative level in 4 kHz reference bandwidth (dB)
-15.0	-81.4
-4.36	-81.4
-3.00	-58.4
-2.86	-51.4
-2.79	-31.4
+2.79	-31.4
+2.86	-51.4
+3.00	-58.4
+4.36	-81.4
+15.00	-81.4

### 1.3 6 MHz channelling DTMB systems

For 6 MHz DTMB systems, the OoB domain extends from  $\pm 3$  MHz (i.e.  $\pm 0.5 \times 6$  MHz) to  $\pm 15$  MHz (i.e.  $\pm 2.5 \times 6$  MHz) relative to channel centre.

Spectrum limit mask for a 6 MHz DTMB system is shown in Fig. 19. The related break points are given in Table 8. The relative power level is defined in a reference bandwidth of 4 kHz. The 0 dB reference level corresponds to the mean output power measured in the channel bandwidth. These emission limits apply when transmitter power is above 39 dBW.

FIGURE 19

## Spectrum limit masks for 6 MHz channelling system D (DTMB)

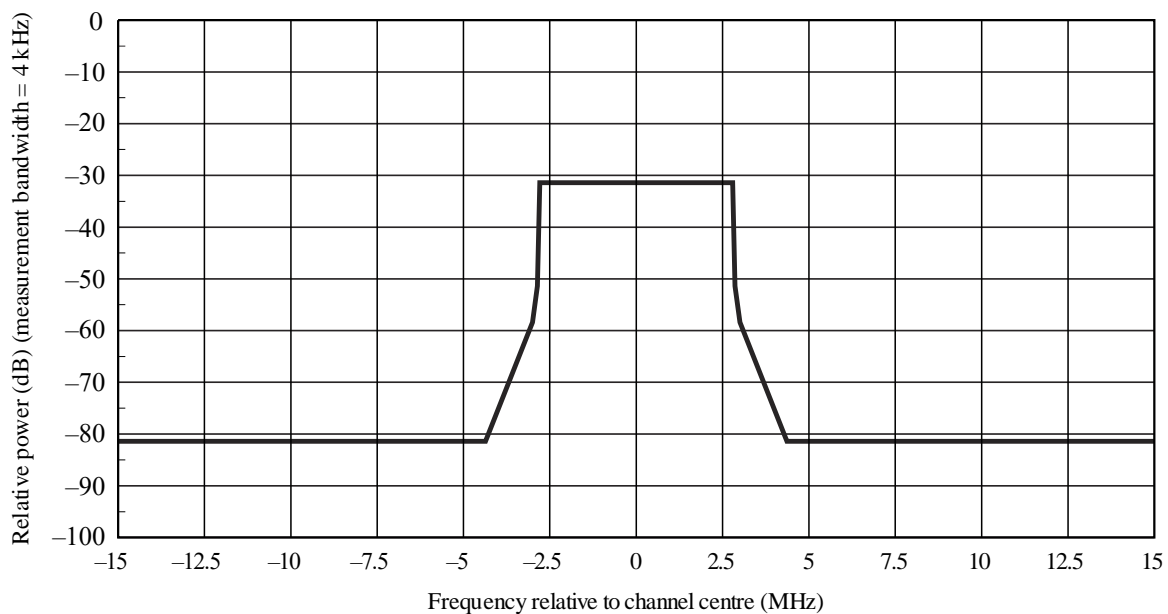



TABLE 8

**Table of break points corresponding to Fig. 19 for 6 MHz channelling system D (DTMB)**

Frequency relative to the centre of the 8 MHz channel (MHz)	Relative level in a 4 kHz measurement bandwidth (dB)
-15	-85
-9	-85
-4.5	-85
-3.15	-73
-2.85	-31.4
2.85	-31.4
3.15	-73
4.5	-85
9	-85
15	-85

#### 1.4 Other 6 MHz digital television systems

OoB domain emission limits for other 6 MHz digital television systems should be based on the national rules of the country using such systems.

## 2 Spectrum masks for 7 and 8 MHz channelling analogue and digital television systems

### 2.1 Analogue television systems

Spectrum limit masks for analogue television are shown in Figs 20, 21 and 22. A generic approach is used to cover the following types of system:

- 7 MHz analogue television, negative modulation, 0.75 MHz vestigial side-band (VSB);
- 8 MHz analogue television, negative modulation, 0.75 and 1.25 MHz VSB;
- 8 MHz analogue television, positive modulation, 0.75 and 1.25 MHz VSB.

Each graph is drawn to represent the spectrum limits for transmitters in the output power range 39 dBW to 50 dBW. Associated with each graph is a table of break points and a table of end point values, together with the corresponding spurious levels, for a range of transmitter output powers.

For 7 MHz analogue television, the OoB domain extends from  $\pm 3.5$  MHz (i.e.  $\pm 0.5 \times 7$  MHz) to  $\pm 17.5$  MHz (i.e.  $\pm 2.5 \times 7$  MHz).

For 8 MHz analogue television, the OoB domain extends from  $\pm 4$  MHz (i.e.  $\pm 0.5 \times 8$  MHz) to  $\pm 20$  MHz (i.e.  $\pm 2.5 \times 8$  MHz).

For both 7 MHz and 8 MHz analogue television, a 50 kHz measurement bandwidth is used to measure unwanted emission levels. The 0 dB reference level corresponds to the peak synch power for negative modulation television systems, or the peak white power for positive modulation television systems. The highest mean power for negative modulation is assumed to be 2.5 dB below peak synch power, and for positive modulation it is assumed to be 1.2 dB below peak white power.

FIGURE 20

Spectrum limit mask for 7 MHz analogue television, negative modulation 0.75 MHz VSB (for  $P=39$  to 50 dBW)

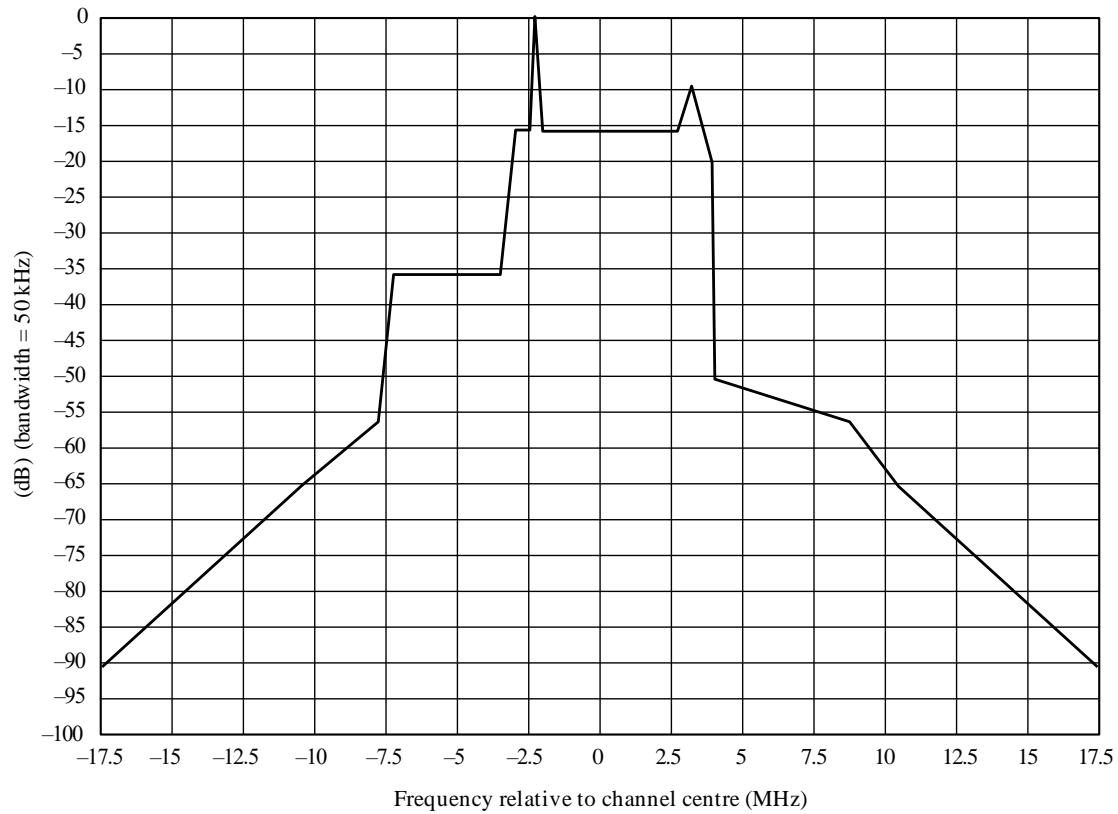

SM.1541-20

Table 9 provides break points corresponding to the graph shown in Fig. 20 for 7 MHz analogue television, negative modulation, 0.75 MHz VSB.

TABLE 9

Break points for 7 MHz analogue television, negative modulation, 0.75 MHz VSB

Frequency relative to the vision carrier frequency	Frequency relative to the centre of the 7 MHz channel	Relative level in 50 kHz measurement bandwidth (dB)
-15.25	-17.5	-90.5
-8.25	-10.5	-65.5
-5.5	-7.75	-56
-5	-7.25	-36
-1.25	-3.5	-36
-0.75	-3	-16
-0.18	-2.43	-16
0	-2.25	0
0.18	-2.07	-16
5	2.75	-16
5.435	3.185	-10

TABLE 9 (*end*)

Frequency relative to the vision carrier frequency	Frequency relative to the centre of the 7 MHz channel	Relative level in 50 kHz measurement bandwidth (dB)
5.565	3.315	-10
6.1	3.85	-20
6.28	4.03	-50
11	8.75	-56
12.75	10.5	-65.5
19.75	17.5	-90.5

Table 10 provides end point values to be used in conjunction with Table 10 and Fig. 20, applicable to a range of transmitter output powers, for 7 MHz analogue television, negative modulation, 0.75 MHz VSB.

TABLE 10

**End point values for 7 MHz analogue television, negative modulation, 0.75 MHz VSB**

End point value <sup>(1)</sup> (50 kHz measurement bandwidth) (dB)	Power range (dBW)	Corresponding spurious level (in 100 kHz measurement bandwidth)
$-80.5 - (P - 9)$	$P \leq 9$	-36 dBm
-80.5	$9 < P \leq 29$	75 dBc
$-80.5 - (P - 29)$	$29 < P \leq 39$	-16 dBm
-90.5	$39 < P \leq 50$	85 dBc
$-90.5 - (P - 50)$	$50 < P$	-5 dBm

<sup>(1)</sup> The end point value is subject to an upper limit of 65.5 dB.

Table 11 provides break points corresponding to the graph shown in Fig. 21, for 8 MHz analogue television, negative modulation, 0.75 MHz and 1.25 MHz VSB.

FIGURE 21

Spectrum limit mask for 8 MHz analogue television, negative modulation (for  $P=39$  to 50 dBW)

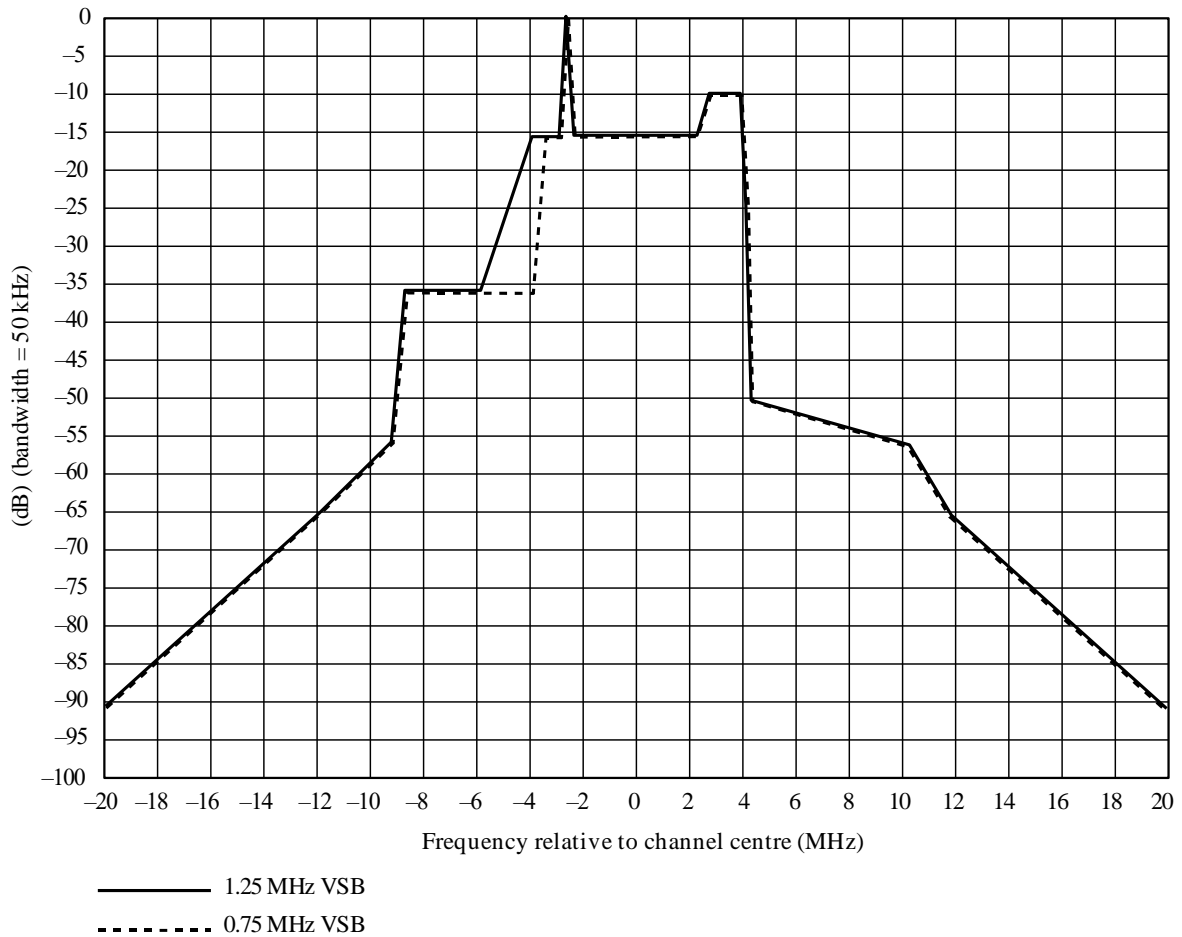

SM.1541-2 1

TABLE 11

Break points for 8 MHz analogue television, negative modulation,  
0.75 MHz and 1.25 MHz VSB

Frequency relative to the vision carrier frequency	Frequency relative to the centre of the 8 MHz channel	Relative level in 50 kHz measurement bandwidth 0.75 MHz VSB (dB)	Relative level in 50 kHz measurement bandwidth 1.25 MHz VSB (dB)
-17.25	-20	-90.5	-90.5
-9.25	-12	-65.5	-65.5
-6.5	-9.25	-56	-56
-6	-8.75	-36	-36
-3	-5.75	-36	-36
-1.25	-4	-36	-16
-0.75	-3.5	-16	-16

TABLE 11 (*end*)

Frequency relative to the vision carrier frequency	Frequency relative to the centre of the 8 MHz channel	Relative level in 50 kHz measurement bandwidth 0.75 MHz VSB (dB)	Relative level in 50 kHz measurement bandwidth 1.25 MHz VSB (dB)
-0.18	-2.93	-16	-16
0	-2.75	0	0
0.18	-2.57	-16	-16
5	2.25	-16	-16
5.435	2.685	-10	-10
6.565	3.815	-10	-10
6.802	4.052	-25	-25
6.94	4.19	-50	-50
13	10.25	-56	-56
14.75	12	-65.5	-65.5
22.75	20	-90.5	-90.5

Table 12 provides end point values to be used in conjunction with Table 11 and Fig. 21, applicable to a range of transmitter output powers, for 8 MHz analogue television, negative modulation.

TABLE 12

**End point values for 8 MHz analogue television, negative modulation**

End point value <sup>(1)</sup> (50 kHz measurement bandwidth) (dB)	Power range (dBW)	Corresponding spurious level (in 100 kHz measurement bandwidth)
$-80.5 - (P - 9)$	$P \leq 9$	-36 dBm
-80.5	$9 < P \leq 29$	75 dBc
$-80.5 - (P - 29)$	$29 < P \leq 39$	-16 dBm
-90.5	$39 < P \leq 50$	85 dBc
$-90.5 - (P - 50)$	$50 < P$	-5 dBm

<sup>(1)</sup> The end point value is subject to an upper limit of 65.5 dB.

Table 13 provides break points corresponding to the graph shown in Fig. 22, for 8 MHz analogue television, positive modulation, 0.75 MHz and 1.25 MHz VSB.

FIGURE 22

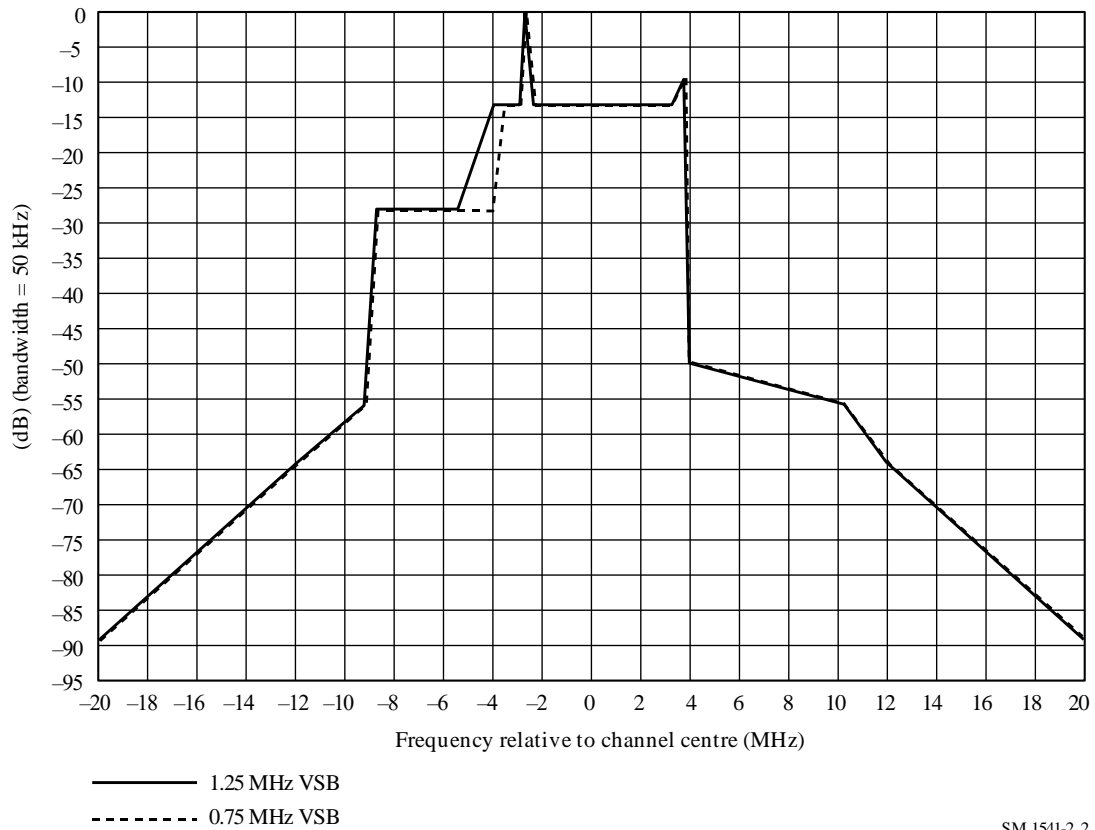
Spectrum limit mask for 8 MHz analogue television, positive modulation (for  $P = 39$  to  $50$  dBW)

SM.1541-2 2

TABLE 13

Break points for 8 MHz analogue television, positive modulation,  
0.75 MHz and 1.25 MHz VSB

Frequency relative to the vision carrier frequency	Frequency relative to the centre of the 8 MHz channel	Relative level in 50 kHz measurement bandwidth 0.75 MHz VSB (dB)	Relative level in 50 kHz measurement bandwidth 1.25 MHz VSB (dB)
-17.25	-20	-89.2	-89.2
-9.25	-12	-64.2	-64.2
-6.5	-9.25	-56	-56
-6	-8.75	-28	-28
-2.7	-5.45	-28	-28
-1.25	-4	-28	-13
-0.75	-3.5	-13	-13
-0.18	-2.93	-13	-13
0	-2.75	0	0
0.18	-2.57	-13	-13
6	3.25	-13	-13
6.435	3.685	-10	-10

TABLE 13 (*end*)

Frequency relative to the vision carrier frequency	Frequency relative to the centre of the 8 MHz channel	Relative level in 50 kHz measurement bandwidth 0.75 MHz VSB (dB)	Relative level in 50 kHz measurement bandwidth 1.25 MHz VSB (dB)
6.565	3.815	-10	-10
6.75	4	-50	-50
13	10.25	-56	-56
14.75	12	-64.2	-64.2
22.75	20	-89.2	-89.2

Table 14 provides end point values to be used in conjunction with Table 13 and Fig. 22, applicable to a range of transmitter output powers, for 8 MHz analogue television, positive modulation.

TABLE 14

**End point values for 8 MHz analogue television, positive modulation**

End point value <sup>(1)</sup> (50 kHz measurement bandwidth) (dB)	Power range (dBW)	Corresponding spurious level (in 100 kHz measurement bandwidth)
$-79.2 - (P - 9)$	$P \leq 9$	-36 dBm
-79.2	$9 < P \leq 29$	75 dBc
$-79.2 - (P - 29)$	$29 < P \leq 39$	-16 dBm
-89.2	$39 < P \leq 50$	85 dBc
$-89.2 - (P - 50)$	$50 < P$	-5 dBm

<sup>(1)</sup> The end point value is subject to an upper limit of 64.2 dB.

## 2.2 Digital television systems

### 2.2.1 7 and 8 MHz DVB-T systems

For 7 MHz digital television, the OoB domain extends from  $\pm 3.5$  MHz (i.e.  $\pm 0.5 \times 7$  MHz) to  $\pm 17.5$  MHz (i.e.  $\pm 2.5 \times 7$  MHz).

For 8 MHz digital television, the OoB domain extends from  $\pm 4$  MHz (i.e.  $\pm 0.5 \times 8$  MHz) to  $\pm 20$  MHz (i.e.  $\pm 2.5 \times 8$  MHz).

For both 7 MHz and 8 MHz digital television, a 4 kHz measurement bandwidth is used to measure unwanted emission levels. The 0 dB reference level corresponds to the mean output power measured in the channel bandwidth.

Spectrum limit masks for 7 MHz and 8 MHz DVB-T systems are shown in Figs 23 and 24 respectively. Each graph is drawn to represent the spectrum limits for transmitters in the output power range 39 dBW to 50 dBW. Associated with each graph is a table of break points and a table of end point and next-to-end point values, together with the corresponding spurious levels, for a range of transmitter output powers.

FIGURE 23

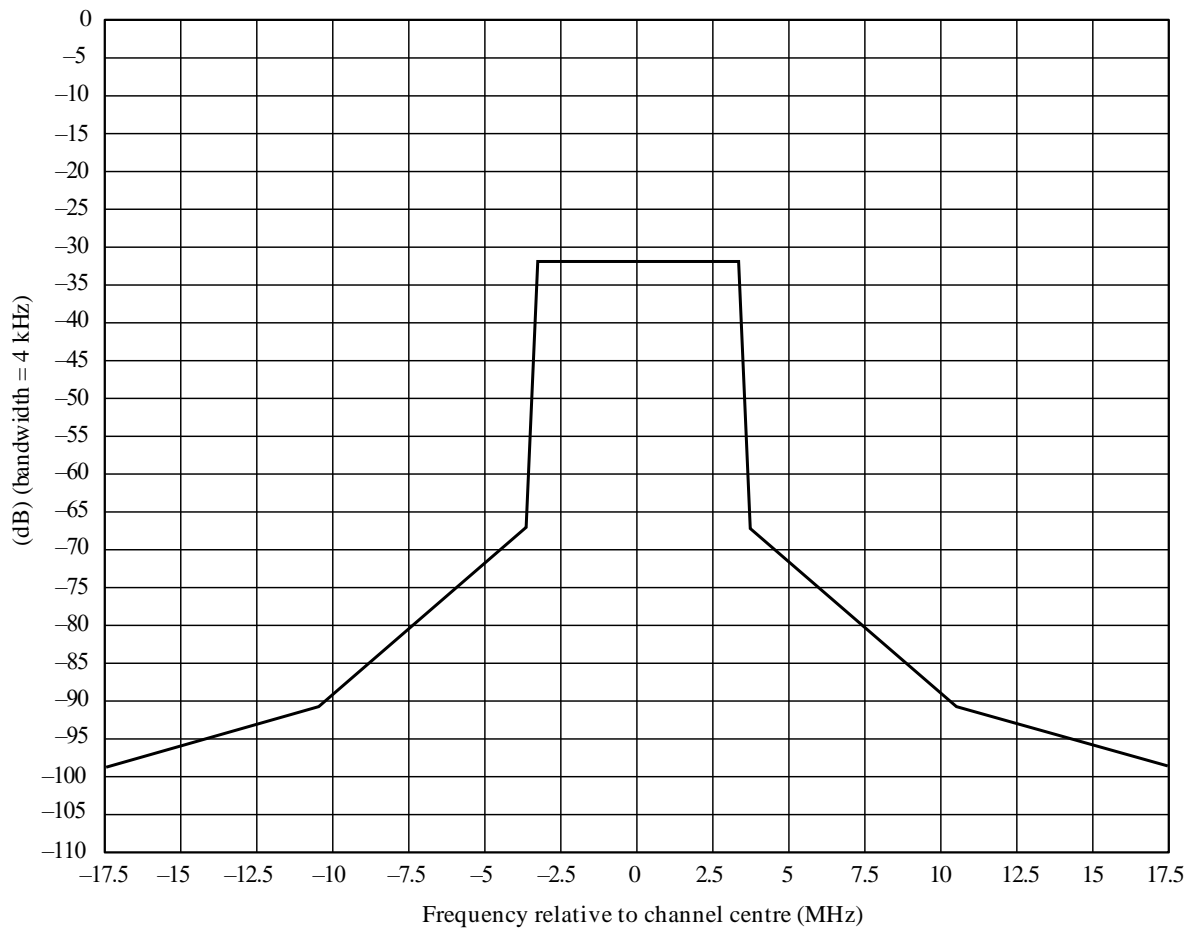
Spectrum limit mask for 7 MHz DVB-T systems (for  $P=39$  to 50 dBW)

SM.1541-2 3

Table 15 provides break points corresponding to Fig. 23, for 7 MHz DVB-T systems.

TABLE 15

Break points for 7 MHz DVB-T systems

Frequency relative to the centre of the 7 MHz channel	Relative level in 4 kHz measurement bandwidth (dB)
-17.5	-99
-10.5	-91
-3.7	-67.2
-3.35	-32.2
3.35	-32.2
3.7	-67.2
10.5	-91
17.5	-99

Table 16 provides end point value and next-to-end point values to be used in conjunction with Fig. 23 and Table 15, applicable a range of transmitter output powers, for 7 MHz DVB-T systems.



TABLE 16  
 End point value and next-to-end point values  
 for 7 MHz DVB-T systems

End point value <sup>(1)</sup> (4 kHz measurement bandwidth) (dB)	Power range (dBW)	Corresponding spurious level (100 kHz measurement bandwidth)
$-89 - (P - 9)$	$P \leq 9$	-36 dBm
-89	$9 < P \leq 29$	75 dBc
$-89 - (P - 29)$	$29 < P \leq 39$	-16 dBm
-99	$39 < P \leq 50$	85 dBc
$-99 - (P - 50)$	$50 \leq P$	-5 dBm

<sup>(1)</sup> The next-to-end point value is 8 dB higher than the end point value and all of these values are subject to an upper limit equal to -67.2 dB.

Table 17 provides break points corresponding to Fig. 24, for 8 MHz DVB-T systems.

FIGURE 24  
 Spectrum limit mask for 8 MHz DVB-T (for  $P = 39$  to 50 dBW)

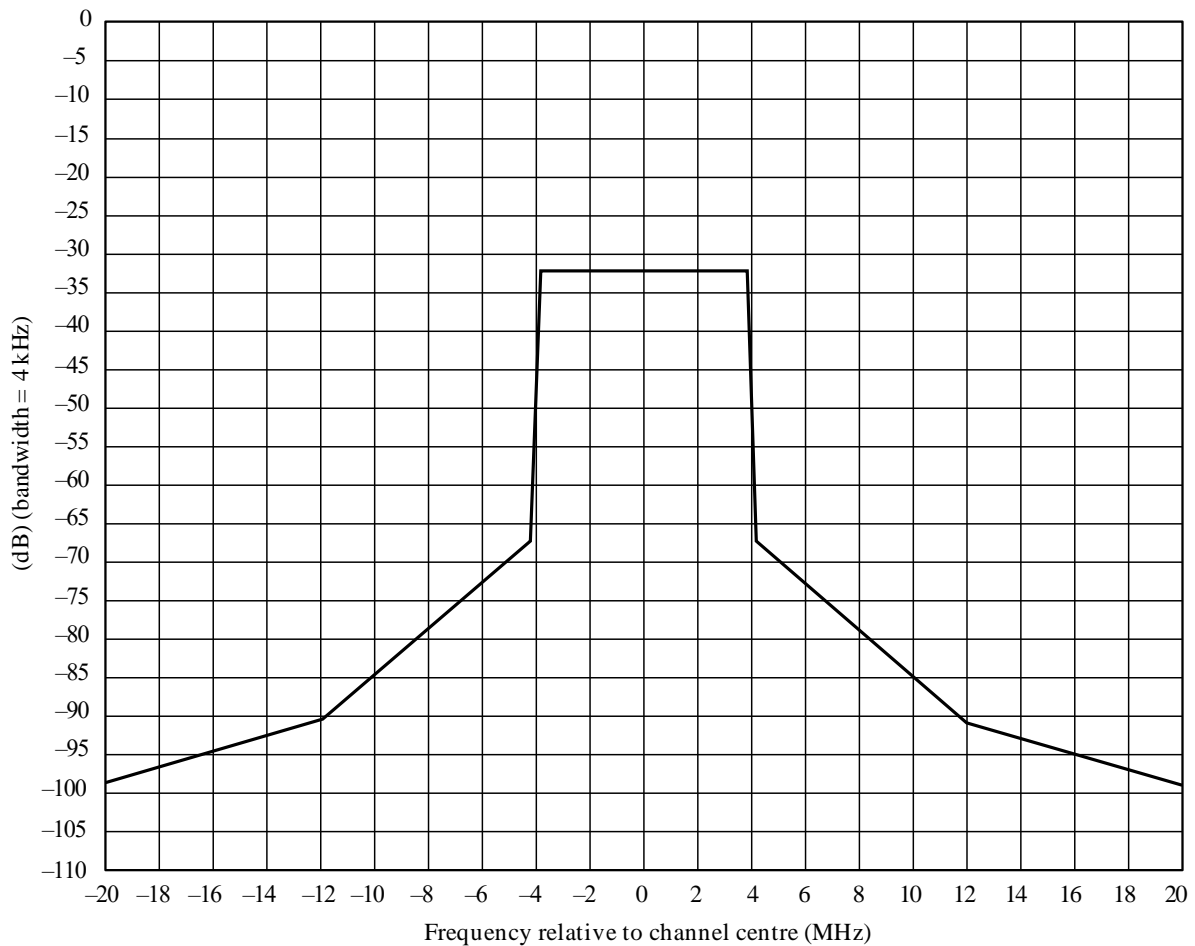

TABLE 17

**Break points for 8 MHz DVB-T systems**

Frequency relative to the centre of the 8 MHz channel	Relative level in 4 kHz measurement bandwidth (dB)
-20	-99
-12	-91
-4.2	-67.8
-3.81	-32.8
3.81	-32.8
4.2	-67.8
12	-91
20	-99

Table 18 provides end point value and next-to-end point values to be used in conjunction with Fig. 24 and Table 17, applicable to a range of transmitter output powers, for 8 MHz DVB-T systems.

TABLE 18

**End point value and next-to-end point values for 8 MHz DVB-T systems**

End point value <sup>(1)</sup> (4 kHz measurement bandwidth) (dB)	Power range (dBW)	Corresponding spurious level (100 kHz measurement bandwidth)
$-89 - (P - 9)$	$P \leq 9$	-36 dBm
-89	$9 < P \leq 29$	75 dBc
$-89 - (P - 29)$	$29 < P \leq 39$	-16 dBm
-99	$39 < P \leq 50$	85 dBc
$-99 - (P - 50)$	$50 \leq P$	-5 dBm

<sup>(1)</sup> The next-to-end point value is 8 dB higher than the end point value and all of these values are subject to an upper limit equal to -67.8 dB.

**2.2.2 7 and 8 MHz ISDB-T systems**

For 7 MHz digital television, the OoB domain extends from  $\pm 3.5$  MHz (i.e.  $\pm 0.5 \times 7$  MHz) to  $\pm 17.5$  MHz (i.e.  $\pm 2.5 \times 7$  MHz).

For 8 MHz digital television, the OoB domain extends from  $\pm 4$  MHz (i.e.  $\pm 0.5 \times 8$  MHz) to  $\pm 20$  MHz (i.e.  $\pm 2.5 \times 8$  MHz).

Spectrum limit masks for 7 MHz and 8 MHz ISDB-T systems are shown in Figs 25 and 26 respectively. Tables 19 and 20 provide break points corresponding to Figs 25 and 26, respectively. The relative power level is defined in a reference bandwidth of 4 kHz. The 0 dB reference level corresponds to the mean output power measured in the channel bandwidth. These emission limits apply when transmitter power is above 39 dBW.

FIGURE 25

Spectrum limit mask for 7 MHz ISDB-T (for  $P > 39$  dBW)

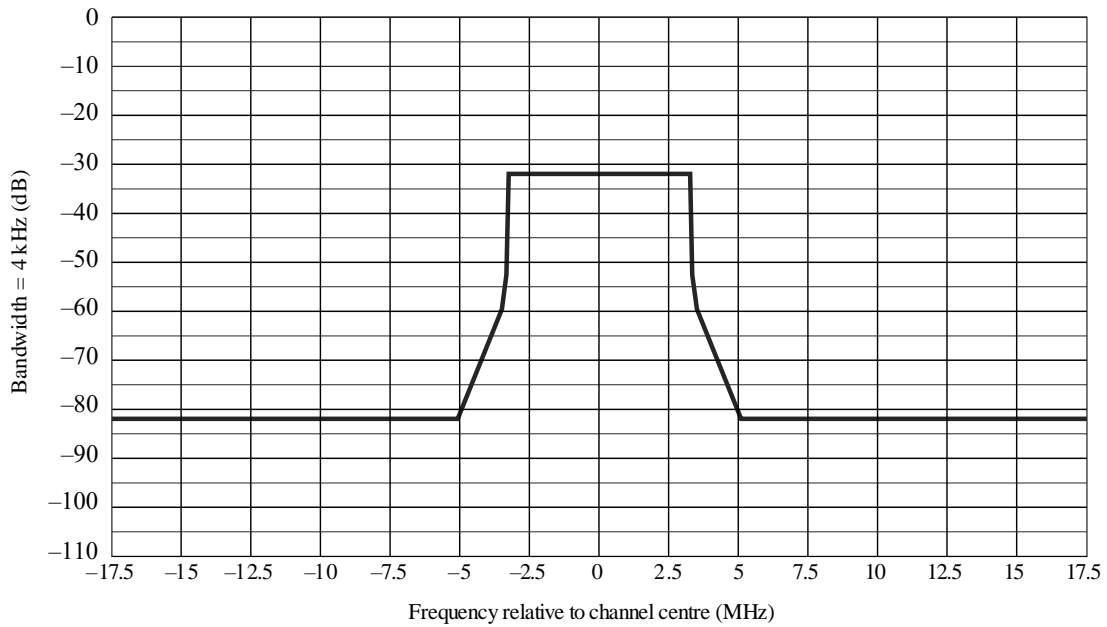

SM.1541- 25

TABLE 19

Table of break points corresponding to Fig. 25 for 7 MHz ISDB-T systems

Frequency relative to the centre of the 7 MHz channel (MHz)	Relative level in a 4 kHz reference bandwidth (dB)
-17.5	-82.1
-5.09	-82.1
-3.50	-59.1
-3.34	-52.1
-3.26	-32.1
+3.26	-32.1
+3.34	-52.1
+3.50	-59.1
+5.09	-82.1
+17.5	-82.1

FIGURE 26

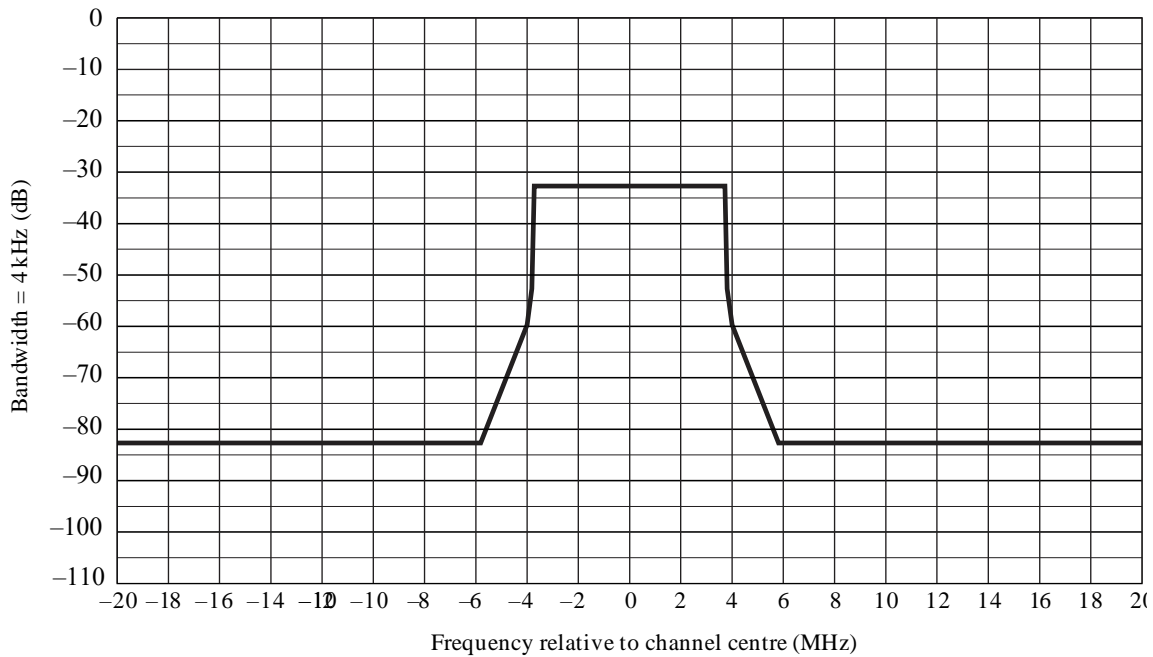
Spectrum limit mask for 8 MHz ISDB-T (for  $P > 39$  dBW)

SM.1541-6

TABLE 20

Table of break points corresponding to Fig. 26 for 8 MHz ISDB-T systems

Frequency relative to the centre of the 8 MHz channel (MHz)	Relative level in a 4 kHz reference bandwidth (dB)
-20.0	-82.7
-5.81	-82.7
-4.00	-59.7
-3.81	-52.7
-3.72	-32.7
+3.72	-32.7
+3.81	-52.7
+4.00	-59.7
+5.81	-82.7
+20.0	-82.7

### 2.2.3 7 and 8 MHz DTMB systems

For 7 MHz digital television, the OoB domain extends from  $\pm 3.5$  MHz (i.e.  $\pm 0.5 \times 7$  MHz) to  $\pm 17.5$  MHz (i.e.  $\pm 2.5 \times 7$  MHz).

For 8 MHz digital television, the OoB domain extends from  $\pm 4$  MHz (i.e.  $\pm 0.5 \times 8$  MHz) to  $\pm 20$  MHz (i.e.  $\pm 2.5 \times 8$  MHz).

Spectrum limit masks for 7 MHz and 8 MHz DTMB systems are shown in Figs 27 and 28 respectively. Tables 21 and 22 provide break points corresponding to Figs 27 and 28, respectively. The relative power level is defined in a reference bandwidth of 4 kHz. The 0 dB reference level

corresponding to the mean output power measured in the channel bandwidth. These emission limits apply when transmitter power is above 39 dBW.

FIGURE 27  
Spectrum limit masks for 7 MHz DTMB

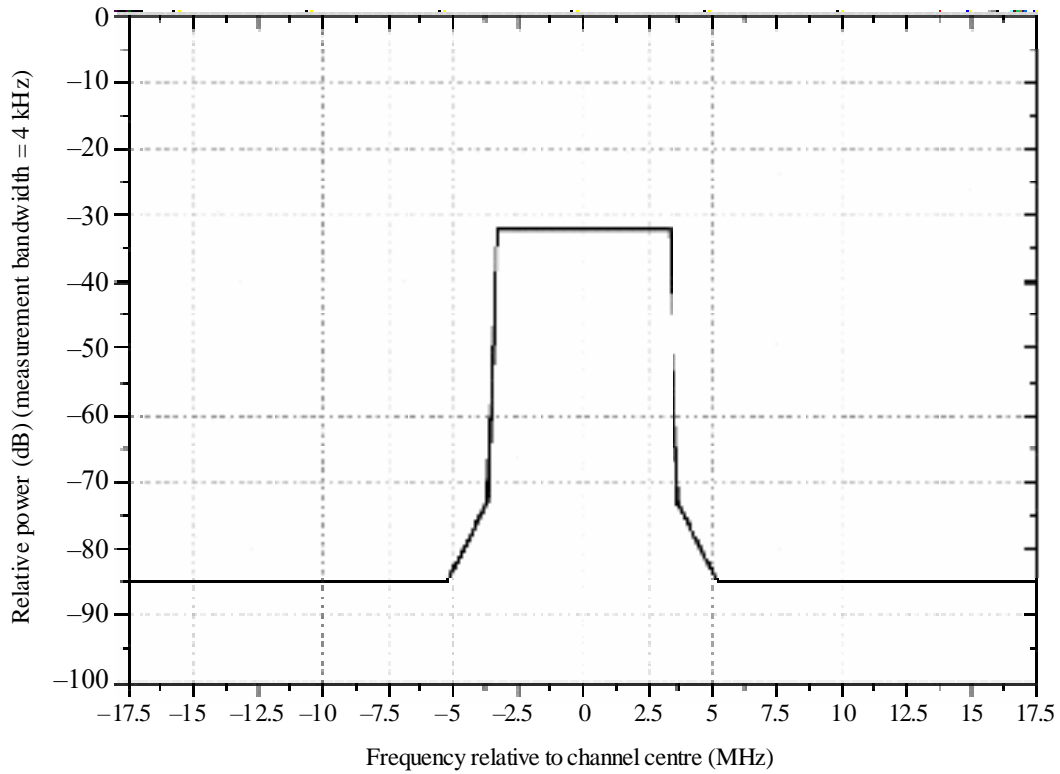

SM.1541-27

TABLE 21

Table of break points corresponding to Fig. 27 for 7 MHz DTMB system

Frequency relative to the centre of the 7 MHz channel (MHz)	Relative level in a 4 kHz measurement bandwidth (dB)
-17.5	-85
-10.5	-85
-5.25	-85
-3.7	-73
-3.33	-32.1
+3.33	-32.1
+3.7	-73
+5.25	-85
+10.5	-85
+17.5	-85

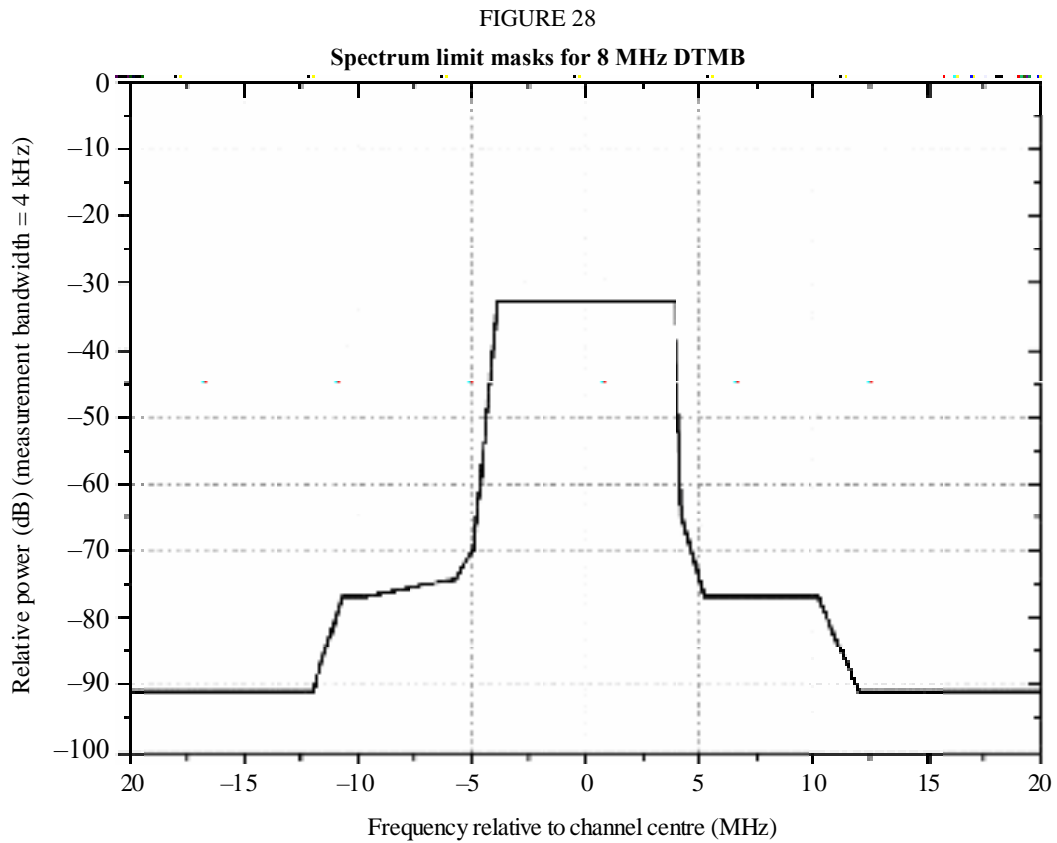

TABLE 22

Table of break points corresponding to Fig. 28 for 8 MHz DTMB system

Frequency offset to the central frequency (MHz)	Relative level (dB)
-20	-91
-12	-91
-10.75	-76.9
-9.75	-76.9
-5.75	-74.2
-4.94	-69.9
-3.9	-32.8
+3.9	-32.8
+4.25	-64.9
+5.25	-76.9
+6.25	-76.9
+10.25	-76.9
+12	-91
+20	-91

## Annex 7

### OoB domain emission limits for sound broadcasting systems

This Annex provides the OoB domain emission limits to be applied to sound broadcasting. According to the safety net principle (see *recommends* 4), it should be noted that more stringent limits are not affected in cases where special agreements for the broadcasting services for coordination and compatibility reasons exist. The more stringent limits specified in the relevant agreements and standards shall be used in all cases where a special need can be indicated and the scope of an agreement would be affected.

#### 1 VHF FM sound broadcasting

The spectrum limit mask for VHF FM sound broadcasting is shown in Fig. 29. The related break points are given in Table 23.

For 200 kHz channelling VHF FM sound broadcasting, the OoB domain extends from  $\pm 100$  kHz (i.e.  $\pm 0.5 \times 200$  kHz) to  $\pm 500$  kHz (i.e.  $\pm 2.5 \times 200$  kHz).

Power level is measured in a 1 kHz bandwidth. The 0 dB reference level corresponds to the mean output power measured in the channel bandwidth (200 kHz).

FIGURE 29

Spectrum limit mask for VHF FM sound broadcasting transmitters (preliminary proposal)

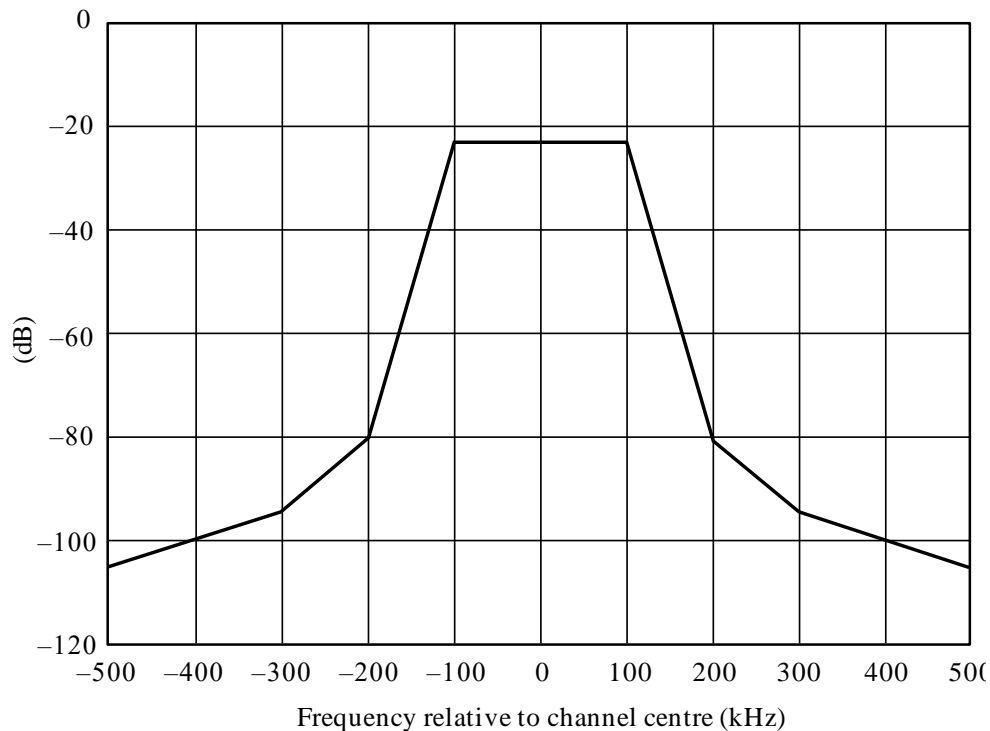

TABLE 23

**Break points of spectrum limit mask  
for VHF FM sound broadcasting**

Frequency relative to the centre of the 200 kHz channel (kHz)	Relative level (dB)
-0.5	-105
-0.3	-94
-0.2	-80
-0.1	-23
0.1	-23
0.2	-80
0.3	-94
0.5	-105

## 2 Sound broadcasting below 30 MHz

OoB domain emissions for double-sideband and single-sideband sound broadcasting transmitter operating below 30 MHz are estimated from Recommendation ITU-R SM.328.

### 2.1 Digital Radio Mondiale systems

For Digital Radio Mondiale (DRM) systems, the OoB domain extends:

- for 4.5 kHz channelling, from  $\pm 2.25$  kHz (i.e.  $\pm 0.5 \times 4.5$  kHz) to  $\pm 11.25$  kHz (i.e.  $\pm 2.5 \times 4.5$  kHz);
- for 5 kHz channelling, from  $\pm 2.5$  kHz (i.e.  $\pm 0.5 \times 5$  kHz) to  $\pm 12.5$  kHz (i.e.  $\pm 2.5 \times 5$  kHz);
- for 9 kHz channelling, from  $\pm 4.5$  kHz (i.e.  $\pm 0.5 \times 9$  kHz) to  $\pm 22.5$  kHz (i.e.  $\pm 2.5 \times 9$  kHz);
- for 10 kHz channelling, from  $\pm 5$  kHz (i.e.  $\pm 0.5 \times 10$  kHz) to  $\pm 25$  kHz (i.e.  $\pm 2.5 \times 10$  kHz).

Recommendation ITU-R BS.1615 – “Planning parameters” for digital sound broadcasting at frequencies below 30 MHz (§ 2.2) provides guidance for defining the DRM spectrum limit masks.

The DRM spectrum limit masks are calculated according to Recommendation ITU-R SM.328, § 6.3.3 of Annex 1, using the channel bandwidths given above. This includes a 30 dB attenuation at  $\pm 0.53 \times$  channel bandwidth; beyond this point there is a slope of  $-12$  dB/octave to  $-60$  dB. The relative power level is defined in a reference bandwidth of 100 Hz. The 0 dB reference level corresponds to the mean output power measured in the channel bandwidth.

An example of a spectrum limit mask for 10 kHz channelling DRM system is shown in Fig. 30.



FIGURE 30

Spectrum limit mask for 10 kHz channelling DRM system

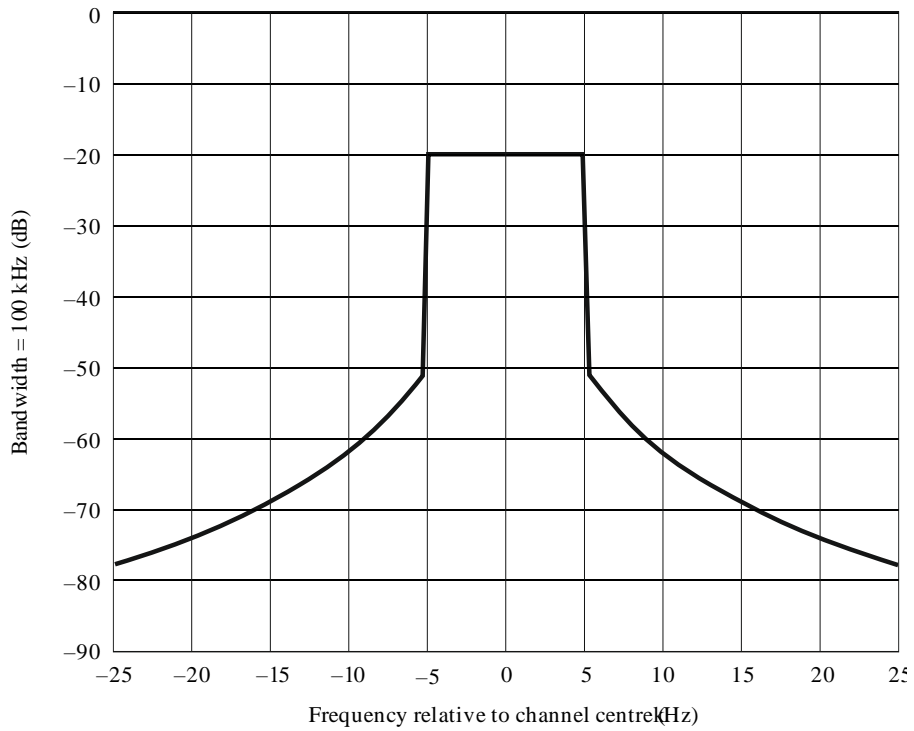

SM.1541-30

### 3 Digital sound broadcasting

#### *Digital System A*

The spectrum limit mask for Digital System A is shown in Fig. 31. The related break points are given in Tables 24 and 25.

For 1.54 MHz channelling Digital System A, the OoB domain extends from  $\pm 0.77$  MHz (i.e.  $\pm 0.5 \times 1.54$  MHz) to  $\pm 3.85$  MHz (i.e.  $\pm 2.5 \times 1.54$  MHz).

For Digital System A, a 4 kHz measurement bandwidth is used. The 0 dB reference level corresponds to the mean output power measured in the channel bandwidth (1.54 MHz).

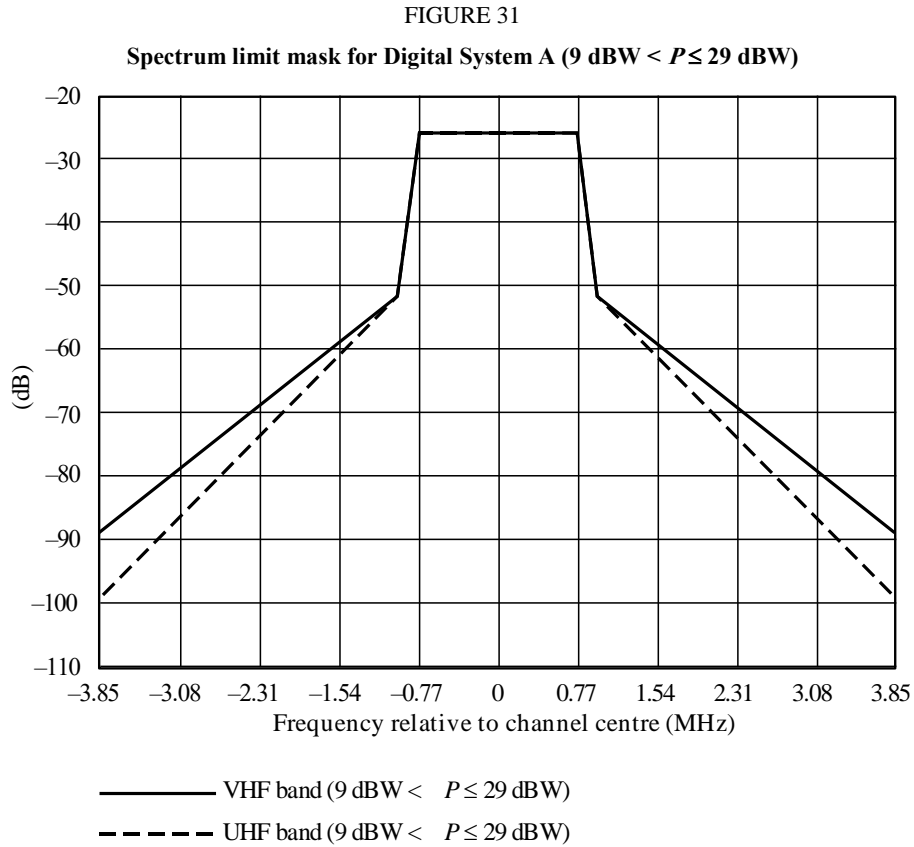

SM.1541- 31

Table 25 provides end point values to be used in conjunction with Table 24 and Fig. 31, applicable to a range of transmitter output powers, for Digital System A.

TABLE 24  
Break points of spectrum limit mask for Digital System A,  
all transmission modes ( $9 \text{ dBW} < P \leq 29 \text{ dBW}$ )

Frequency relative to the centre of the 1.54 MHz channel (MHz)	Relative level (dB)
-3.85	-89
-0.97	-52
-0.77	-26
0.77	-26
0.97	-52

TABLE 25

End point values to be used in conjunction with Table 24

Digital System A operating in the bands 47-68 MHz and 174-240 MHz		
End point value <sup>(1)</sup> (dB/4 kHz)	Power range (dBW)	Corresponding spurious level (100 kHz measurement bandwidth)
$-89 - (P - 9)$	$P \leq 9$	-36 dBm
-89	$9 < P \leq 29$	75 dBc
$-89 - (P - 29)$	$29 < P \leq 39$	-16 dBm
-99	$39 < P \leq 50$	85 dBc
$-99 - (P - 50)$	$50 < P$	-5 dBm
Digital System A operating in the band 1 452-1 467.5 MHz		
End point value <sup>(1)</sup> (dB/4 kHz)	Power range (dBW)	Corresponding spurious level (1 MHz measurement bandwidth)
$-99 - (P - 9)$	$P \leq 9$	-36 dBm
-99	$9 < P \leq 29$	75 dBc
$-99 - (P - 29)$	$29 < P \leq 39$	-16 dBm
-106	$39 < P \leq 50$	85 dBc
-106	$50 < P$	-5 dBm

<sup>(1)</sup> The end point value is subject to an upper limit equal to -52 dB and a lower limit equal to -106 dB.

## Annex 8

### OoB domain emission limits for primary radar systems

#### 1 Introduction

The RR define “primary radar” as “A *radiodetermination* system based on the comparison of reference signals with radio signals reflected from the position to be determined”.

Terrestrial primary radars operate in the radionavigation service (air surveillance radars and navigation radars on aircraft and ships), the meteorological aids service (weather radars), and the radiolocation service (most other terrestrial radars). Space-based radars include active remote sensing satellites operating in the SRS (active) and EESS (active), and other radars in the SRS.

The following limits are not applicable inside exclusive radiodetermination and/or EESS (active) and SRS (active) bands, but do apply at the band edges. The topic of primary radar emission limits within these exclusive service bands will be the subject of further studies.

Several categories of primary radars are not included in the OoB emission limits defined in this Annex. These include pulsed radars with rated peak power of 1 kW or less, non-pulsed radars with

rated average power of 40 W or less, radars operating above 40 GHz, man-portable radars, and expendable radars on missiles. These categories of radars will also be the subject of further studies to establish the appropriate limits.

Throughout this Annex, in all formulas, bandwidth ( $B_N$ ,  $B_c$ ,  $B_s$ ,  $B_d$ ,  $B_{-40}$ ,  $B_{rise}$ ,  $B_{fall}$ ,  $B_{rise\&fall}$ ,  $B_R$ ) is expressed in Hertz, while pulse duration and rise/fall time are expressed in seconds, unless otherwise noted.

## 2 Necessary bandwidth

Knowledge of the necessary bandwidth of a radar transmitter is required both for specifying the OoB domain emission limits and for specifying the boundary beyond which spurious limits apply.

Recommendation ITU-R SM.1138, to which the RR makes reference, provides formulas to be used to calculate the necessary bandwidth when required by the RR. However, the only formula applicable to radar gives results that can vary by a factor of ten based on a constant chosen by the user. Recommendation ITU-R SM.853, considering that the formulas in Recommendation ITU-R SM.1138 are incomplete, recommends numerous supplemental formulas.

### 2.1 Un-modulated radar pulses

Recommendation ITU-R SM.853 provides guidance for determining the necessary bandwidth (20 dB below the peak envelope value) for rectangular and trapezoidal pulses. For these systems, the necessary bandwidth  $B_N$  is the smaller of:

$$B_N = \frac{1.79}{\sqrt{t \cdot t_r}} \text{ or } \frac{6.36}{t} \quad (35)$$

where  $t$  is the pulse duration (at half amplitude) and  $t_r$  is the rise time, both in seconds<sup>3</sup>.

### 2.2 Other modulations

Necessary bandwidth formulas for frequency modulated pulse radars, frequency hopping radars, and CW radars, both un-modulated and frequency modulated are presented below. For frequency modulated pulse radars, the necessary bandwidth (20 dB bandwidth) formula exceeds the symmetrical trapezoidal pulse case (equation (35)) by twice the frequency deviation  $B_c$ <sup>4</sup>:

$$B_N = \frac{1.79}{\sqrt{t \cdot t_r}} + 2B_c \quad (36)$$

The formula for frequency hopping radars has an additional term  $B_s$ , the maximum range over which the carrier frequency will be shifted:

---

<sup>3</sup> The pulse duration is the time, (s) between the 50% amplitude (voltage) points. For coded pulses, the pulse duration is the interval between 50% amplitude points of one chip (sub-pulse). The rise time is the time taken (s) for the leading edge of the pulse to increase from 10% to 90% of the maximum amplitude on the leading edge. For coded pulses, it is the rise time of a sub-pulse; if the sub-pulse rise time is not discernible assume that it is 40% of the time to switch from one phase or sub-pulse to the next. When the fall time of the radar is less than the rise time, it should be used in place of the rise time in these equations. Using the smaller of the two expressions in equation (35) avoids excessively large calculated necessary bandwidth when the rise time is very short.

<sup>4</sup> This value is the total frequency shift during the pulse duration.

$$B_N = \frac{1.79}{\sqrt{t \cdot t_r}} + 2B_c + B_s \tag{37}$$

Although Recommendation ITU-R SM.1138 gives no formula under the heading of “continuous wave emission” (here meaning a carrier without modulation) a realistic value of necessary bandwidth for un-modulated continuous wave (CW) radars depends on the frequency tolerance and noise. For frequency modulated CW radars, the necessary bandwidth is twice  $B_d$ , the maximum frequency deviation:

$$B_N = 2B_d \tag{38}$$

### 2.3 Typical values of necessary bandwidth

Table 26 shows typical necessary bandwidths, followed by the ranges of the necessary bandwidth values, for four types of radars.

TABLE 26

Type of radar	Typical $B_N$ (MHz)	Range of $B_N$
Fixed radiolocation radar	6	20 kHz to 1.3 GHz
Mobile radiolocation radar	5.75	250 kHz to 400 MHz
Airport surveillance radar	6	2.8 MHz to 15 MHz
Weather radar	1	250 kHz to 3.5 MHz

## 3 OoB domain emission limits for primary radars

A major difficulty in establishing general OoB domain emission limits for primary radars is the diversity of systems and transmitted waveforms. OoB domain emission limits for primary radars are based on the 40 dB bandwidth ( $B_{-40}$ ) of the spectrum of the transmitted waveform.

### 3.1 Formulas for the $B_{-40}$ dB bandwidth

Since the ratio of the  $B_{-40}$  dB and necessary bandwidths is not in general a constant, a formula for the  $B_{-40}$  dB bandwidth is needed to relate the mask to necessary bandwidth. The following formulas for the  $B_{-40}$  dB bandwidth of primary radar transmitters have been established.

For non-FM pulse radars, including spread spectrum or coded pulse radars, the bandwidth is the lesser of:

$$B_{-40} = \frac{K}{\sqrt{t \cdot t_r}} \text{ or } \frac{64}{t} \tag{39}$$

where the coefficient  $K$  is 6.2 for radars with output power greater than 100 kW and 7.6 for lower-power radars and radars operating in the radionavigation service in the 2 900-3 100 MHz and

9 200-9 500 MHz bands<sup>5</sup>. The latter expression applies if the rise time  $t_r$  is less than about  $0.0094t$  when  $K$  is 6.2, or about  $0.014t$  when  $K$  is 7.6.

For FM-pulse radars, the  $B_{-40}$  dB bandwidth is:

$$B_{-40} = 1.5 \left\{ B_C + \sqrt{\pi} \cdot [\ln(B_C \cdot \tau)]^{0.53} \cdot [\text{Min}(B_{rise}, B_{fall}, B_{rise \& fall}) + \text{Max}(B_{rise}, B_{fall}, B_{rise \& fall})] \right\} \quad (40)$$

where:

$$B_{rise} = \frac{1}{\sqrt{\tau \cdot t_r}} \quad \text{to account for the rise time} \quad (41)$$

$$B_{fall} = \frac{1}{\sqrt{\tau \cdot t_f}} \quad \text{to account for the fall time} \quad (42)$$

$$B_{rise \& fall} = \frac{1}{\sqrt[3]{\tau \cdot t_r \cdot t_f}} \quad \text{to account for both the rise and fall times combination} \quad (43)$$

$\tau$ : pulse length including rise and fall times

$t_r$ : pulse rise time

$t_f$ : pulse fall time

$B_C$ : bandwidth of the frequency deviation (total frequency shift during the pulse generation)

$B_S$ : the maximum range over which the carrier frequency will be shifted,  $B_S$  equals zero for non-frequency hopping cases.

Equation (40) is valid only when the following conditions are met:

1. the product  $B_C \cdot \text{Minimum}(t_r, t_f)$  is greater than or equal to 0.10; and
2. that the product of  $B_C \cdot \tau$  or compression ratio must be greater than 10.

---

<sup>5</sup> These coefficients,  $K = 6.2$  or  $7.6$  and  $64$ , are related to theoretical values that would prevail in the case of constant frequency trapezoidal and rectangular pulses, respectively. Also, in the case of the trapezoidal pulses, the coefficient  $K$  has been increased somewhat to allow for implementing output device characteristics. For ideal rectangular pulses, the spectrum falls off at 20 dB per decade leading to a 20 dB bandwidth of  $6.4/t$  and a  $B_{-40}$  dB bandwidth ten times as large, i.e.  $64/t$ . To discourage the use of pulses with abrupt rise and fall times, no margin is allowed. The spectra of trapezoidal pulses fall off firstly at 20 dB per decade and then ultimately at 40 dB per decade. If the ratio of rise time to pulse width exceeds 0.008 the 40 dB points will fall on the 40 dB per decade slope, in which case the  $B_{-40}$  would be:

$$\frac{5.7}{\sqrt{t \cdot t_r}}$$

Allowance for unavoidable imperfections in implementation requires that the mask be based on values of at least:

$$\frac{6.2}{\sqrt{t \cdot t_r}} \quad \text{or} \quad \frac{7.6}{\sqrt{t \cdot t_r}}$$

depending upon the category of radar.

In all other cases, the following equations should be used:

$$B_{-40} = \frac{K}{\sqrt{t \cdot t_r}} + 2 \left( B_c + \frac{A}{t_r} \right) \quad (44)$$

where  $A^6$  is 0.105 when  $K = 6.2$ , and 0.065 when  $K = 7.6$ .

For FM-pulse radars with frequency hopping, the value of  $B_s$  needs to be added to the value of  $B_{-40}$  (equation (40) or equation (44)) for the frequency hopping radar  $B_{-40}$  dB bandwidth<sup>7</sup>.

For unmodulated CW radars, the  $B_{-40}$  dB bandwidth is:

$$B_{-40} = 0.0003 F_c \quad (45)$$

where  $F_c$  is the carrier frequency.

For frequency modulated continuous wave (FMCW) radars, two different  $B_{-40}$  dB bandwidth formulas apply. These are a general formula and a frequency hopping formula.

The general  $B_{-40}$  dB bandwidth formula for FMCW radars is:

$$B_{-40} = 1.2 B_R \left( 1 + \frac{200}{\pi \sqrt{B_R T}} \right)^{1/2} \quad (46)$$

where  $B_R$  is the total frequency deviation and  $T$  is the chirp period. This formula is based on linear FMCW and can also be applied to amplitude modulated linear FMCW, flyback FMCW, and non-linear FMCW.

For FMCW radars with frequency hopping, the value of  $B_s$  needs to be added to the  $B_{-40}$  dB bandwidth formula, where  $B_s$  is the maximum range over which the carrier frequency will be shifted.

For radars with multiple pulse waveforms, the  $B_{-40}$  dB bandwidth should be calculated for each individual pulse type and the maximum  $B_{-40}$  dB bandwidth obtained shall be used to establish the shape of the emission mask.

#### 4 OoB mask

The figures below show the OoB mask for primary radars, categorized by waveform types and specified in terms of psd and expressed in units of dBpp. The masks roll off from the  $B_{-40}$  dB bandwidth to the spurious level specified in RR Appendix 3<sup>8</sup>.

The  $B_{-40}$  dB bandwidth can be offset from the frequency of maximum emission level, but the necessary bandwidth (RR No. 1.152) and preferably the overall occupied bandwidth (RR No. 1.153) should be contained completely within the allocated band.

---

<sup>6</sup> The term  $A/t_r$  adjusts the value of  $B_{-40}$  to account for the influence of the rise time, which is substantial when the time-bandwidth product  $B_c t$ , is small or moderate and the rise time is short.

<sup>7</sup> This yields the total composite  $B_{-40}$  bandwidth of frequency hopping radar as if all channels included within  $B_s$  were operating simultaneously. For frequency hopping radars, the OoB emission mask falls off from the edge of the  $B_{-40}$  dB bandwidth as though the radar were a single frequency radar tuned to the edge of the frequency hopping range.

<sup>8</sup> RR Appendix 3 specifies a spurious attenuation of  $43 + 10 \log (PEP)$ , or 60 dB, whichever is less stringent. (PEP: peak envelope power.)

For guidance, the calculated value of the  $B_{-40}$  dB bandwidth should be contained completely within the allocated band.

#### 4.1 All waveforms listed in § 3

The roll-off for all waveforms listed in § 3, other than those listed in § 4.2, is 30 dB per decade, as shown in Fig. 32.

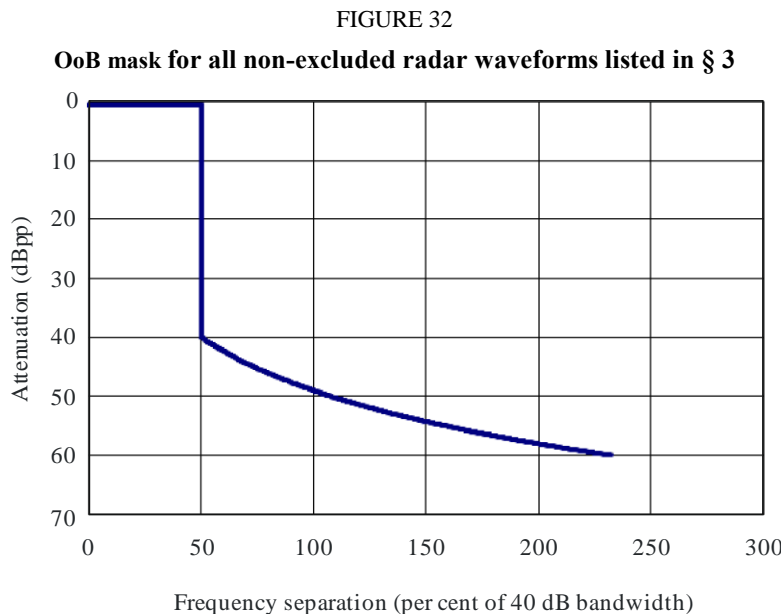

SM.1541-32

#### 4.2 Excluded waveforms

CW, FMCW, and phase coded waveforms are excluded from the applicability of § 4.1. The rate of roll off for these is 20 dB per decade, as shown in Fig. 33.

This exclusion should be reviewed in the study period before the 2016 Radiocommunication Assembly.

### 5 Boundary between the OoB and spurious domains

According to *recommends* 2.2 and RR Appendix 3, the spurious domain generally begins at a frequency separation equal to 250% of the necessary bandwidth, with exceptions for certain kinds of systems, including those with digital or pulsed modulation. However, it is difficult to apply the general boundary concept of 250% of the necessary bandwidth to primary radar stations in the radiodetermination and other services, such as the meteorological aids service, SRS and EESS.

For primary radar stations, the boundary between the OoB and spurious domains is defined as at the frequency where the OoB domain emission limits defined herein are equal to the spurious limit defined in Table II of RR Appendix 3.

The boundary between the OoB and spurious domains in the case of primary radars in the radiodetermination service and other relevant services can be defined as separated from the assigned frequency by  $2.5 \alpha B_N$ , where  $\alpha$  is a boundary correction factor depending on the total system configuration, in particular the modulation waveform and modulating technique, the radar output device, waveguide components and the antenna type and its frequency dependent characteristics. The value of  $\alpha$  will also depend on the way the necessary bandwidth is evaluated.



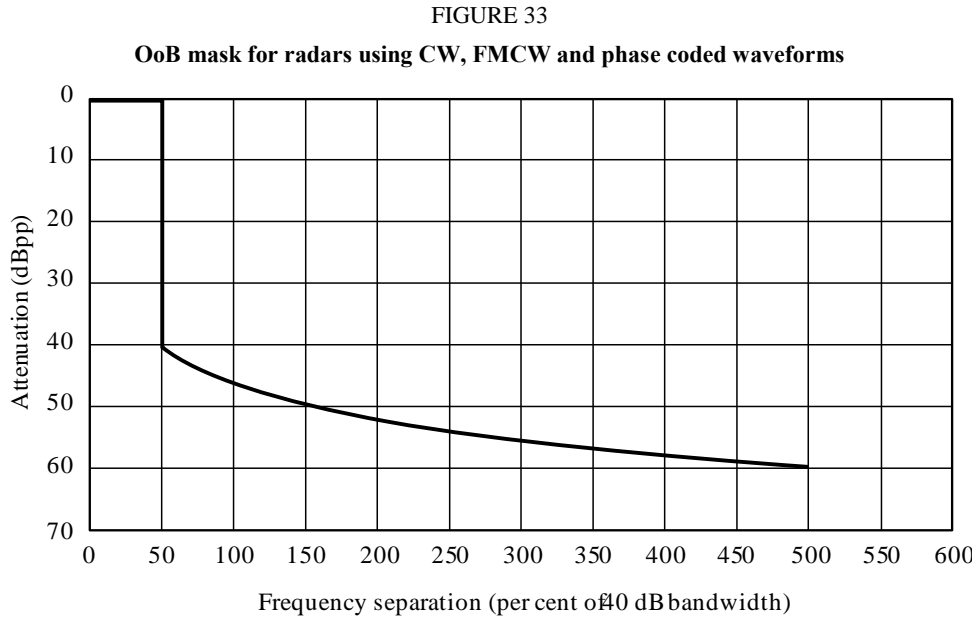

SM.1541-6

The values of  $\alpha$  corresponding to the mask in Fig. 33 can be determined by setting the 60 dB point equal to  $2.5 \alpha B_N$ . Assuming a 20 dB per decade roll-off:

$$5B_{-40} = 2.5\alpha B_N \rightarrow \alpha = 2 \frac{B_{-40}}{B_N} \quad (47)$$

Using the examples above,  $\alpha$  would be about 2.0 for the linear FM pulse radar and about 8.5 for the non-FM pulse radar. This equation does not apply to the frequency hopping case.

Assuming that the necessary bandwidth is evaluated as the 20 dB bandwidth, technical information available so far has indicated that, for existing and planned primary radars, the value of  $\alpha$  would range from 1 to 10, or more.

From the standpoint of effective use of spectrum, it can be questioned:

- whether the future primary radars will be able to meet an  $\alpha$  value closer to 1 or not;
- whether  $\alpha$  should be different depending on whether the boundary between the OoB and spurious domains will be inside, outside or close to a primary radar allocated band.

Further studies need to be conducted within the ITU-R to specify the definition of the necessary bandwidth to be used in the calculation of the boundary and to define the values of  $\alpha$  for the different type of radars, missions and platforms.

For non-FM pulsed radars, in a few exceptional cases where the system architecture permits the use of filters and unusual performance trade-offs can be tolerated, the value of  $\alpha$  may approach 1. Also, for wideband frequency agile radars, the value of  $\alpha$  may be close to 1.5.

## 6 Design objective

The preceding sections of this annex are based on the safety-net principle of OoB domain emission limits. It is recognized that it is desirable to reduce the levels of unwanted emissions to enhance compatibility with other services.

The mask in Fig. 34 is the objective for the design of radar systems. The mask rolls off at 40 dB per decade from the  $B_{-40}$  dB bandwidth to the spurious level specified in RR Appendix 3.

Radars should be designed to meet the requirement of the design objective mask. Where possible, radar design should avoid the use of technologies that are not capable of meeting the design objective.

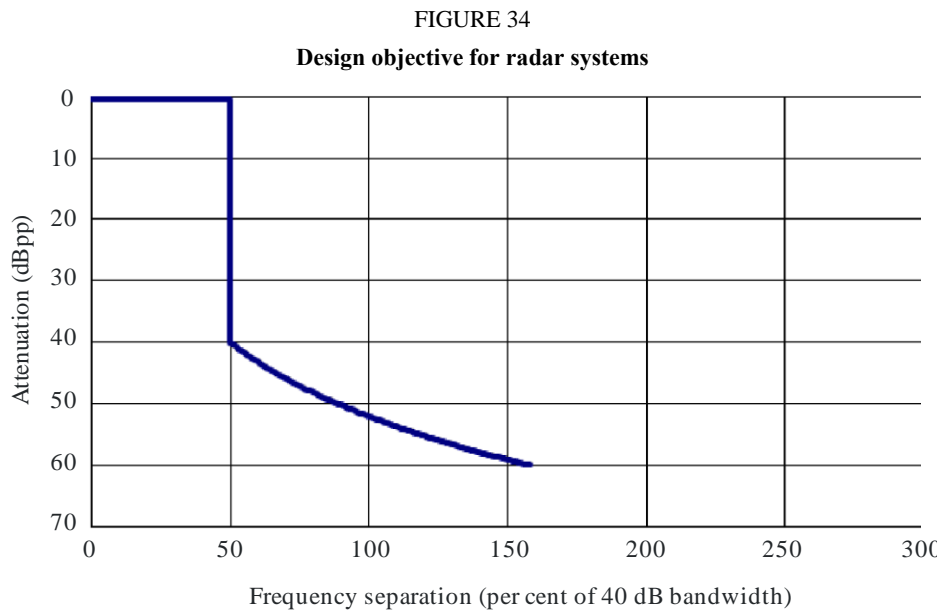

SM.1541-34

*Note 1* – The feasibility of this mask is to be investigated in future studies within ITU-R, taking account of the practical experience of its application to some types of radar systems and technical developments in radar technology. Inputs to ITU (study periods 2003-2007 and 2007-2011) have provided evidence that some types of radars can achieve the design objective. These include some klystron-based radars and some radars using strapped vane magnetrons below 100 kW as the output device.

*Note 2* – OoB domain emission limits within bands allocated to the radiodetermination service on an exclusive basis are the subject of further study. This study may result in a different design objective mask inside these bands.

*Note 3* – Some future systems may not be able to achieve the design objective taking account of such factors as:

- radar mission (safety of life, target size to be detected, etc.);
- type and size of the platform (e.g. fixed, mobile, ship-borne, airborne, etc.);
- available technologies and their state of evolution;
- affordability.

*Note 4* – The intention is that these studies will lead to the revision of this Recommendation to either replace the OoB masks in the preceding sections with the design objective mask; or to include other appropriate arrangements depending on the type of radar waveform by the 2016 Radiocommunication Assembly.

## 7 Measurement techniques

The most recent version of Recommendation ITU-R M.1177 provides guidance regarding the methods of measuring OoB domain emissions from radar systems.

Annex 9

OoB domain emission limits for the amateur services

Stations operating in the amateur and amateur satellite services should meet the limits contained in the following spectrum masks.

FIGURE 35  
Stations operating below 30 MHz in the normal or narrow-band cases of Recommendation ITU-R SM.1539

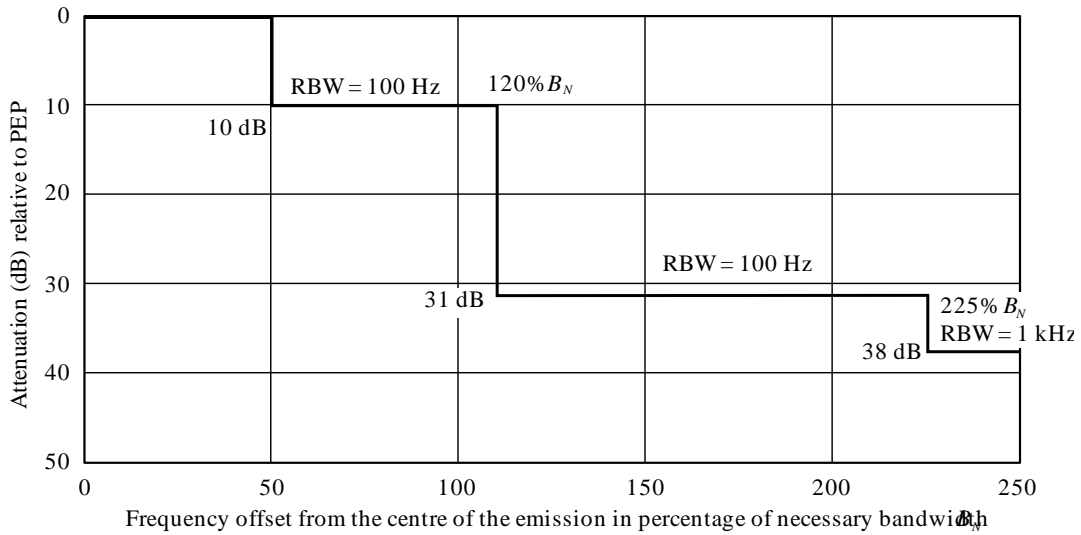

SM.1541-5

Where  $B_N < 4$  kHz, the value of  $B_L$  from Recommendation ITU-R SM.1539 is to be used instead of  $B_N$ .

FIGURE 36  
Stations operating below 30 MHz in the wideband cases of Recommendation ITU-R SM.1539

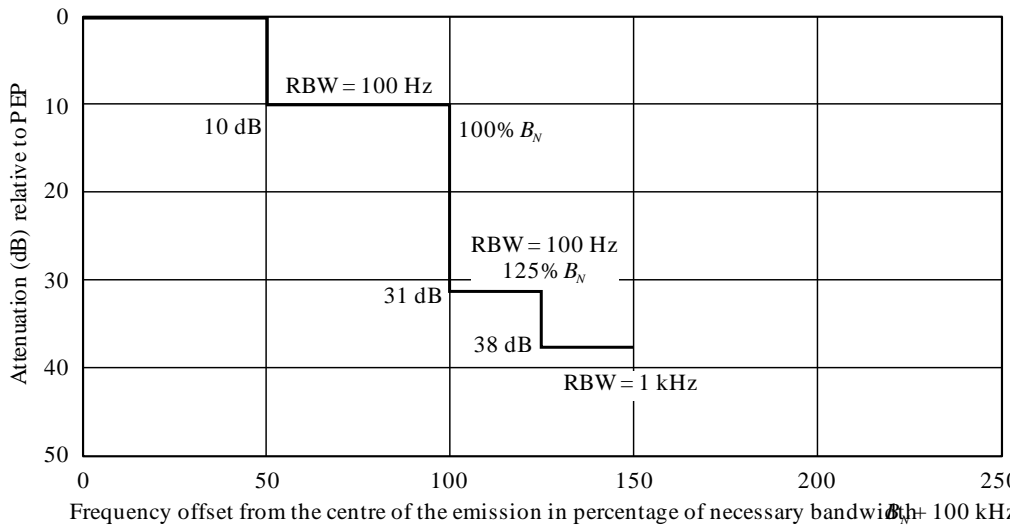

SM.1541-7

FIGURE 37

Stations operating above 30 MHz in the normal or narrow-band cases of Recommendation ITU-R SM.1539

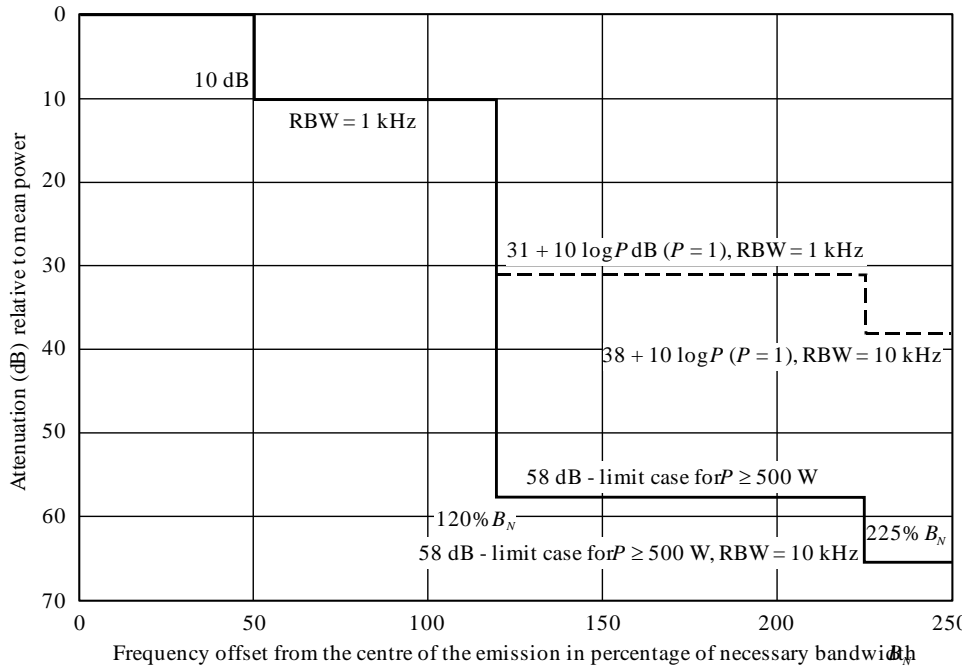

SM 1541-3

In the narrow-band case, the value of  $B_L$  derived from Recommendation ITU-R SM.1539 is to be used instead of  $B_N$ .

FIGURE 38  
**Stations operating above 30 MHz in the wideband cases of  
 Recommendation ITU-R SM.1539**

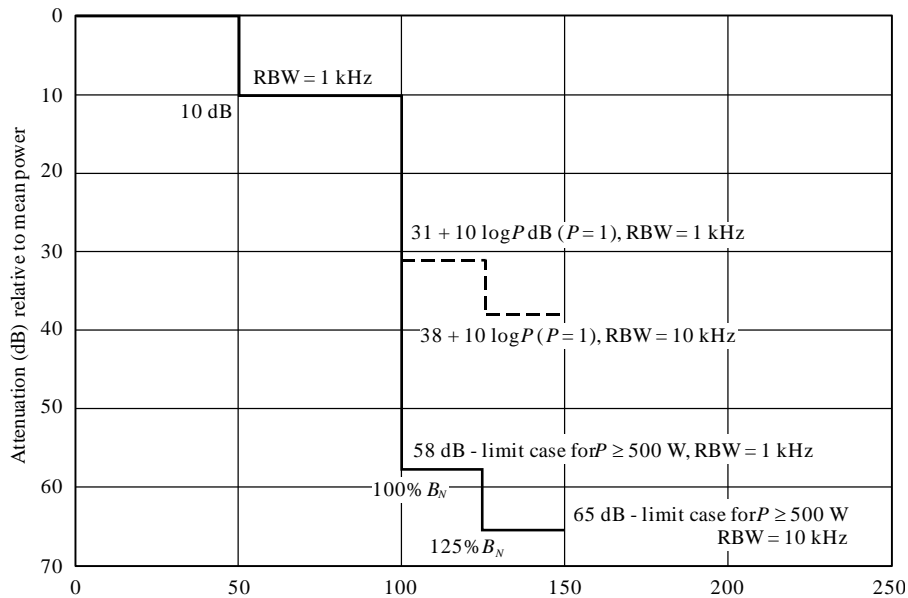

Frequency offset from the centre of the emission in percentage of necessary bandwidth to which the separation value given in Recommendation ITU-R SM.1539 is to be added to obtain the actual frequency offset.

PEP: peak envelope power (W) supplied to the antenna transmission line in accordance with RR No. 1.157

P: mean power (W) supplied to the antenna transmission line in accordance with RR No. 1.158

SM 1541 31

NOTE 1 – All classes of emission using single sideband (SSB) are included in the category SSB.

Where applicable, the modulation applied for test purposes is audio frequency tones of 1 100 and 1 700 Hz for SSB transmissions, with 1 kHz for emissions with a carrier, or in other cases, with modulation representative of normal use.

NOTE 2 – For stations using wideband frequency division multiple access (FDMA), such as space stations operating in the amateur satellite service, the necessary bandwidth shall be considered to be the 3 dB bandwidth of the transmitter final amplifier.

## Annex 10

### OoB domain emission limits land mobile radio services

The masks contained in this annex are examples of some OoB masks used for the land mobile service. A generic mask addressing all the systems in the land mobile service needs to be further studied. This service has indicated its preference to use adjacent band (or channel) power ratio limits rather than limit curves as it facilitates frequency coordination and system planning. Appendix 1 to Annex 1 shows how a band power limit can be derived from an emission mask.

Table 27 provides break points corresponding to the graph shown in Fig. 39 for 12.5 kHz channel bandwidth land mobile systems.

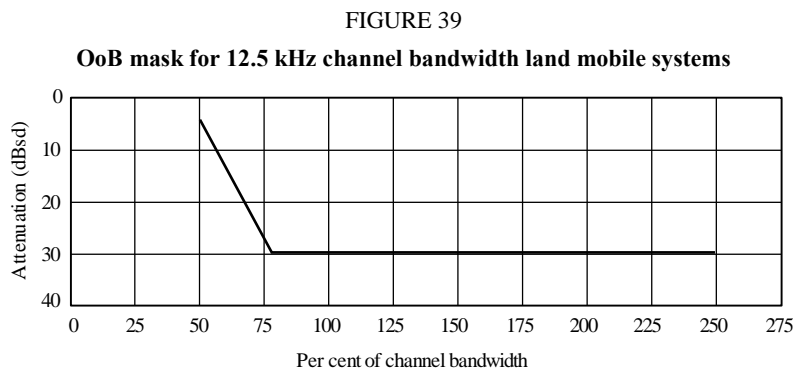

SM.1541- 39

TABLE 27

#### Break points

Frequency offset from the centre frequency (% of channel bandwidth)	Attenuation (dBsd)
50	3.5
78	29
250	29

Table 28 provides break points corresponding to the graph shown in Fig. 40 for 5 kHz channel bandwidth amplitude companded SSB.

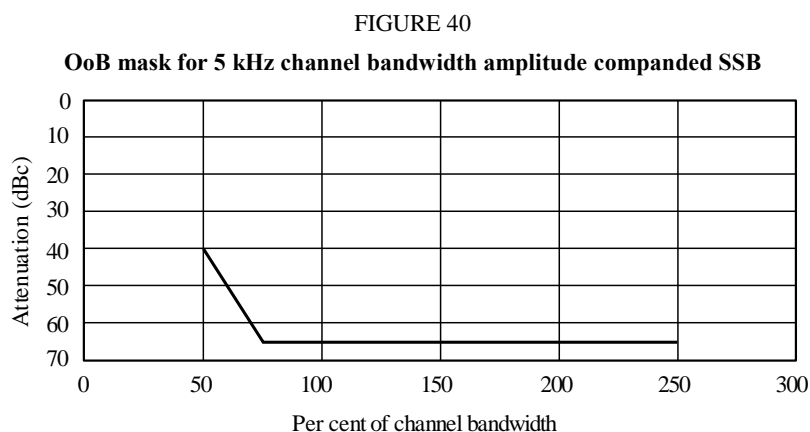

SM1541- 40

TABLE 28  
Break points

Frequency offset from the centre frequency (% of channel bandwidth)	Attenuation (dBc)
50	40
75	65
250	65

Table 29 provides break points corresponding to the graph shown in Fig. 41 for 6.5 kHz channel bandwidth land mobile systems.

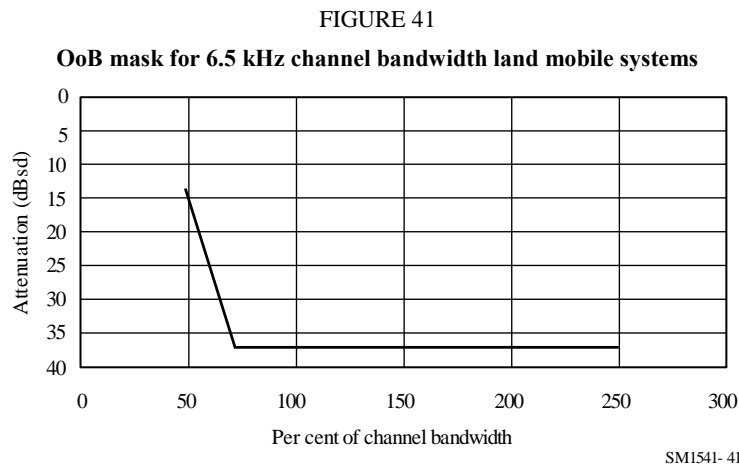

TABLE 29  
Break points

Frequency offset from the centre frequency (% of channel bandwidth)	Attenuation (dBsd)
50	14
72	37
250	37

Table 30 provides break points corresponding to the graph shown in Fig. 42 for 30 kHz channel bandwidth analogue cellular systems.

FIGURE 42

OoB mask for 30 kHz channel bandwidth analogue cellular systems

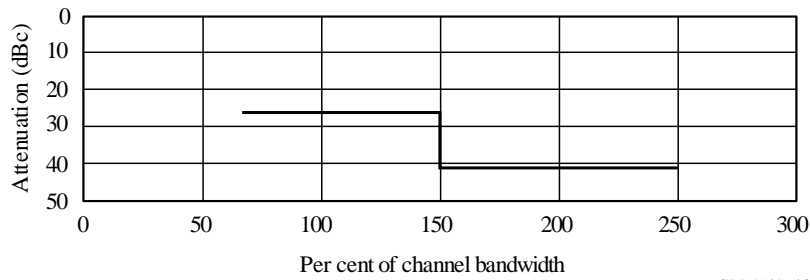

SM.1541- 42

TABLE 30

Break points

Frequency offset from the centre frequency (% of channel bandwidth)	Attenuation (dBc)
67	26
150	26
150	41
250	41

## Annex 11

### OoB domain emission limits for aeronautical-mobile and maritime-mobile services

These emission masks are specified in terms of power in a reference bandwidth relative to the total carrier power (dBc). OoB domain emissions are specified in a bandwidth of 4 kHz, except for those from single-sideband and aeronautical transmitters. Single-sideband emissions are specified in a narrower bandwidth and aeronautical telemetry emissions are specified in terms of the specific spectrum analyser settings: 10 kHz resolution bandwidth, 1 kHz video bandwidth and max hold. The boundary between the OoB and spurious domains for these emission masks is 250% of the necessary bandwidth, in agreement with RR Appendix 3.

#### 1 Aeronautical telemetry

For aeronautical telemetry transmitters, the limits of any emission in the OoB domain (50% to 250%) relative to the mean power of the transmitter, are:

$$-(55 + 10 \log P)$$

or

$$K + 90 \log R - 100 \log |f - fc| \quad \text{for } |f - fc| \geq \frac{R}{m}$$



where:

- $K = -20$ , for analogue signals
- $K = -28$ , for binary signals
- $K = -63$ , for quaternary signals (e.g. FQPSK-B)
- $f_c$ : transmitter centre frequency (MHz)
- $R$ : bit rate (Mbit/s) for digital signals or  $(\Delta f + f_{max})$  (MHz) for analogue FM signals
- $m$ : number of states in modulating signal
  - $m = 2$ , for binary signals
  - $m = 4$ , for quaternary signals and analogue signals
- $\Delta f$ : peak deviation
- $f_{max}$ : maximum modulation frequency

whichever is less restrictive.

Figure 43 shows examples of OoB masks for aeronautical telemetry, specified in terms of dBc. The occupied bandwidths used in generating Fig. 43 were 1.16 times the bit rate for binary signals and 0.78 times the bit rate for quaternary signals. Additional parameters used in Fig. 43 were power,  $P$ , of 10 W and bit rate,  $R$ , of 5 Mbit/s. These values vary from system to system and the resulting emission masks vary according to the equation presented above. The emission masks roll off at 100 dB/decade.

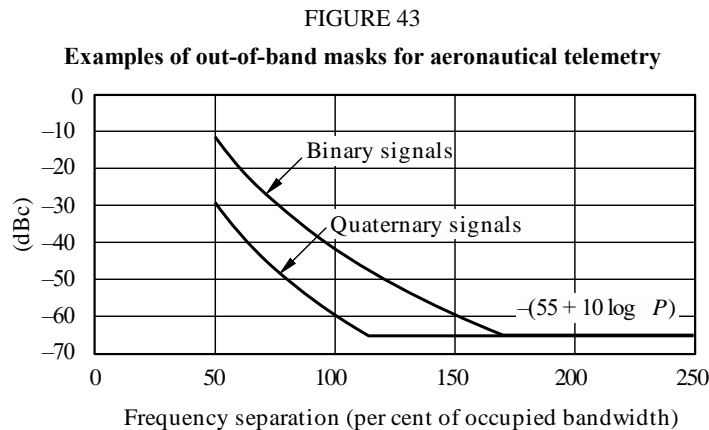

SM.1541- 43

## 2 Other aeronautical-mobile and maritime-mobile transmitters

For aeronautical-mobile and maritime-mobile transmitters other than aeronautical telemetry and exempted systems, the required attenuation of the mean power of any emission in the OoB domain, relative to the mean power of the transmitter, is:

50-150%	25 dBc
150-250%	35 dBc

FIGURE 44

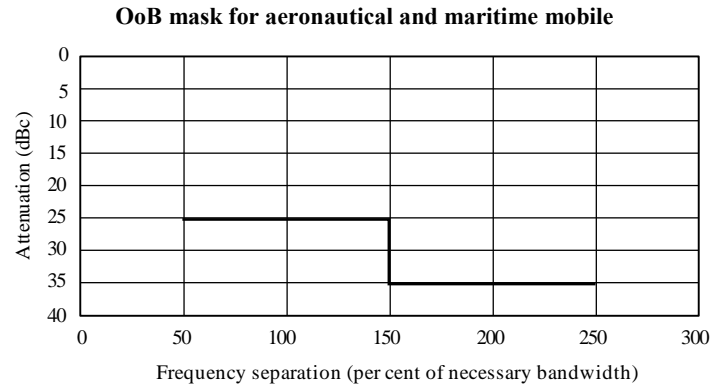

## Annex 12

### OoB domain emission limits for the fixed service

Recommendation ITU-R F.1191 requires that, for digital radio relay systems, operating on a specific radio-frequency channel arrangement, the frequency boundaries between spurious and OoB domains are  $\pm 250\%$  of the relevant channel separation (CS). Therefore, for the purpose of this Recommendation, the OoB domain emission limits of analogue and digital fixed service systems are defined, whenever applicable, up to the  $\pm 250\%$  of the relevant CS of the radio-frequency channel arrangement where the system is to be placed.

According to Recommendation ITU-R F.1191, the CS is taken as  $XS/2$  for alternated frequency channel arrangements and  $XS$  for co-channel and interleaved frequency channel arrangements as defined by Recommendation ITU-R F.746.

Where exclusive block assignments (see Note 1) are made, transmitters operating on sub-channels devised by the licensed operator could, in principle, be exempted, within the block, by the unwanted emissions limit required to be met outside the block; however at country borders this should require agreement between the administrations concerned due to the fact that they may have licensed the band in a different way.

The spectrum masks specified in this annex are intended as generic limits, which generally constitute the least restrictive OoB emission limits successfully used as national or regional regulations. These are sometimes called safety net limits. They are intended for use in bands where tighter masks are not otherwise required to protect specific applications.

These masks are a composite maximum limit for any application and frequency band of deployment in any climatic zone; however actual spectrum masks are usually designed more tightly according the adjacent channel interference rejection required by the specific application (e.g. frequency band, modulation format sensitivity and quality of service required) in different geo-climatic conditions ( $K$  factor as defined in Recommendation ITU-R P.530).

NOTE 1 – A block-assignment (see definition in Recommendation ITU-R F.1399) is the case of a block of spectrum assigned to one or more stations of an operator under a single exclusive licence (see examples in Recommendations ITU-R F.1488, ITU-R F.748 and ITU-R F.749). Inside a single block-assignment, the

operator may, in general, subdivide the block into suitable smaller sub-blocks or sub-channels in order to deploy a radio network in the geographical area where the assignment has been made.

## 1 Digital fixed service: spectrum emission masks

### 1.1 Systems operating above 30 MHz

Spectrum attenuation masks are shown in Fig. 45.

The 0 dBsd reference level is taken as the maximum value of the psd inside the occupied bandwidth.

For measurement purposes the resolution bandwidth used should be around 1% of the occupied bandwidth.

FIGURE 45  
Generic spectrum masks for digital fixed service operating above 30 MHz  
(see Table 31)

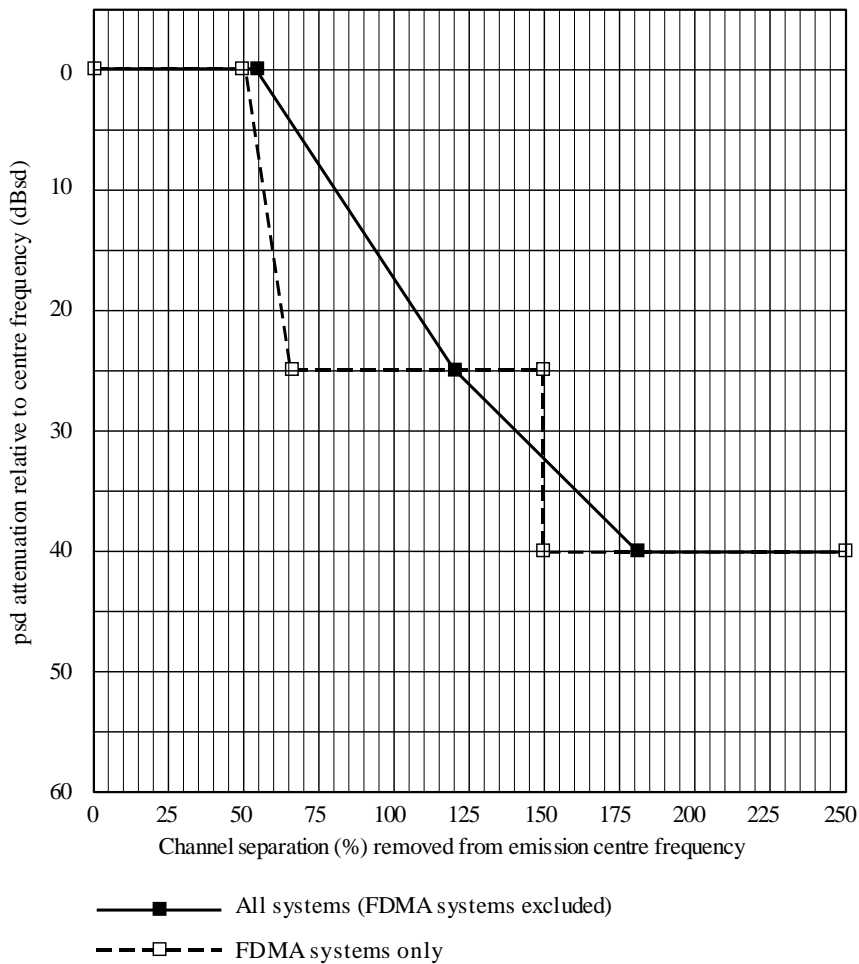

*Note 1* – The masks specified are expressed as function of CS percentage, however, for systems operating in frequency bands where no radio-frequency channel arrangement is established, the CS percentage should be substituted by necessary bandwidth percentage or, if applicable by the "lower threshold of necessary bandwidth" as defined by Recommendation ITU-R SM.1539. When not elsewhere specified in ITU-R Recommendations, the necessary bandwidth should be derived from Recommendation ITU-R F.1191.

TABLE 31

**Digital fixed service operating above 30 MHz**  
(Reference to Fig. 45)

All systems (FDMA excluded)		FDMA systems only	
Frequency offset (CS %)	Attenuation (dBsd)	Frequency offset (CS %)	Attenuation (dBsd)
0	0	0	0
55	0	50	0
120	25	65	25
180	40	150	25
250	40	150	40
		250	40

## 1.2 Systems operating below 30 MHz

Spectrum attenuation masks are shown in Fig. 46.

The 0 dBsd reference level is taken as the maximum value of the psd inside the occupied bandwidth.

FIGURE 46

**Generic spectrum masks for digital fixed service operating below 30 MHz**  
(see Table 32)

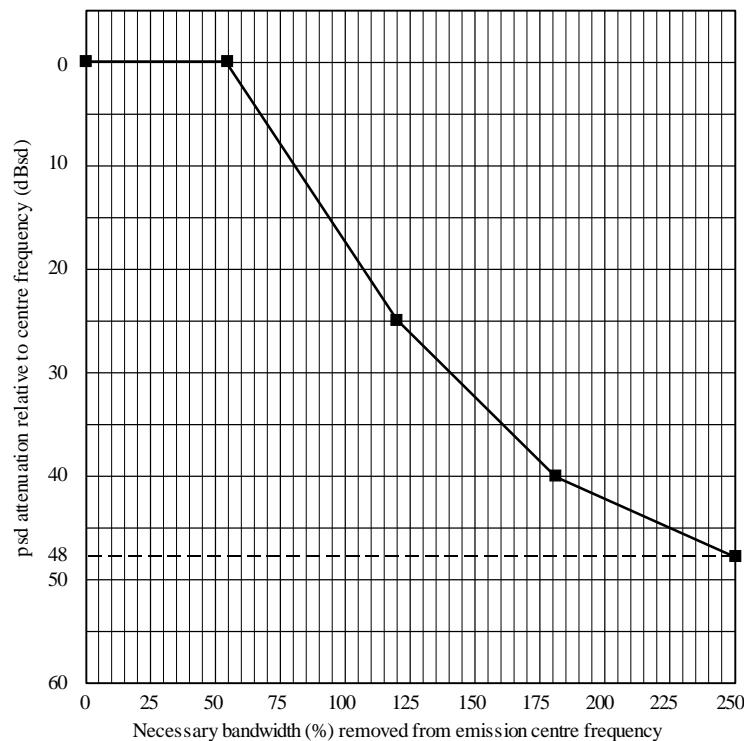

Necessary bandwidth (%) removed from emission centre frequency  
*Note 1* – When applicable, the lower threshold of necessary bandwidth, as defined by Recommendation ITU-R SM.1539 should be used. When not elsewhere specified in ITU-R Recommendations, the necessary bandwidth should be derived from Recommendation ITU-R F.1191.

TABLE 32

**Digital fixed service operating below 30 MHz**  
(Reference to Fig. 46)

All systems	
Frequency offset (CS %)	Attenuation (dBsd)
0	0
55	0
120	25
180	40
250	48

## 2 Digital fixed service: discrete spectral lines within OoB emission boundaries

Discrete spectral lines are not considered within spectral density masks but should be limited not to impair the unwanted emission power produced by the spectrum itself as follows:

### 2.1 Systems operating above 30 MHz

- Spectral lines inside  $\pm 50\%$  of channel separation: OoB domain emission limit is not applicable.
- Total mean power of all spectral lines between  $+50\%$  and  $+150\%$  or between  $-50\%$  and  $-150\%$  of channel separation: 23 dBc.
- Total mean power of all spectral lines between  $+150\%$  and  $+250\%$  or between  $-150\%$  and  $-250\%$  of Channel Separation: 45 dBc.

NOTE 1 – When no channel separation is defined the necessary bandwidth could be used.

### 2.2 Systems operating below 30 MHz

The spectral lines falling in the OoB domain, between  $+50\%$  and  $+250\%$  or between  $-50\%$  and  $-250\%$  of the necessary bandwidth should meet the spurious limit as defined by Recommendation ITU-R SM.329.

## 3 Analogue fixed service

Radiocommunication Study Group 9 – Fixed Service, decided in 1991 not to support any longer development of Recommendations on analogue systems (see Recommendation ITU-R F.745).

Even if still in operation, new development of analogue systems are not likely to happen; therefore there is no need for safety net masks in this Recommendation.

## Annex 13

### OoB domain emission measurements

#### 1 Measuring equipment

##### 1.1 Selective measuring receiver

A spectrum analyser or other suitable equipment with sufficient amplitude dynamic range to accurately perform measurements over the range of attenuation specified for the chosen method should be used for the measurement of power supplied to the antenna. If the dynamic range is not sufficient for the required measurements, filtering techniques (e.g. pre-selection or notch filters) may be applicable to solve the measurement of OoB domain emissions.

Principally there are two ways of specifying OoB domain emission limits, a) the spectrum mask method and b) the method of specifying adjacent channel and alternate adjacent channel powers.

- a) For measurements using the OoB mask method (see Annex 1), the measuring receiver needs the ability to simultaneously display the limiting curve and the emission psd. Also needed is the ability to enter the line segments needed to describe and store the various segments of the limit curves, some of which need an algebraic equation.
- b) For measurements using the adjacent-channel and alternate-adjacent-channel-power method (see Annex 1), the measuring receiver needs the ability to compute the power in a specified bandwidth using numerical summation of a set of measurements made in smaller sub-bands. An alternative method is the use of channel filters for direct power measurement in an adjacent or alternate adjacent channel. Also needed is the ability to enter, store and display the channel edges.

##### 1.1.1 Detectors of measurement equipment

The measurement receiver may include the root mean square (r.m.s.), sample and peak detector functions. It is important to note that these will generally not report the same value depending on the characteristics of the signal analysed so it is important to correct readings for the detector function (i.e. the signal processing) requirement for a specific measurement, if only one of the detectors is provided.

Many analysers use the conventional detector function of the signal passing through a logarithmic amplifier, then through an envelope detector. This results in a signal processing error for non CW signals, as the mean of the logarithmic value will not be equal to the logarithm of the mean value. When measuring Gaussian noise this results in the log average value reported to be low by 1.45 dB and a further additional 1.05 dB needs to be added to correct for the difference between the linear average value and the mean power of this signal characteristic. So, if the linear average value of Gaussian noise is measured instead of the r.m.s. value, this results in a systematic error of  $-2.5$  dB.

Those analysers which contain digital signal processing capability serve to eliminate the need to provide these corrections by performing a true mean power measurement function by prior digitizing of the incoming signal and performing the power conversion numerically.

Errors of this type may be minimized or eliminated if a power ratio is measured, rather than absolute power, if the settings remain constant. This condition generally exists with those analysers equipped with an adjacent channel power ratio capability. This however applies only where the signal statistics of the occupied channel and the adjacent channel are the same (e.g. Gaussian). Figure 47 gives an example where this is not the case.

FIGURE 47

Code division multiple access (IS95) uplink spectrum measured with true mean power measurement function (upper) and trace averaging (lower)

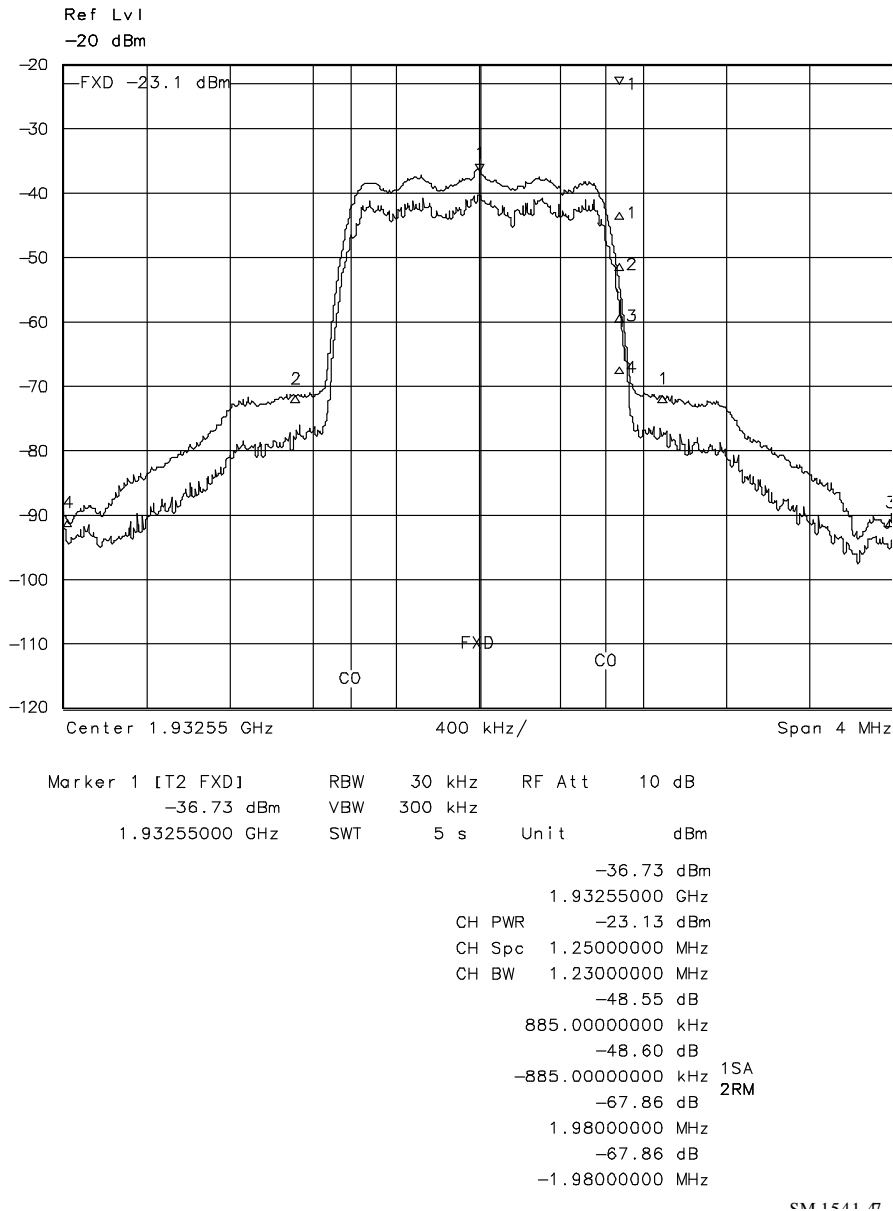

The level differences are different between the occupied and the adjacent channels.

### 1.1.2 Resolution bandwidths

The resolution bandwidth should be ideally the recommended value of the reference bandwidth. For the psd and the mean power (for dBc) the bandwidth should be the same for in-band and OoB measurements. However, the actual value of the resolution bandwidth of the IF filter used in an analyser may not be equal to that specified even though the setting may agree. This will result in an error needing correction, generally not exceeding 1.5 dB, for improved accuracy when measuring the psd of a signal in the bandwidth of the filter.

Since those analysers which containing digital signal processing functions also contain digital filtering, this type of analyser generally has a more accurate implementation of the filter bandwidth setting. Further any correction needed can be provided in the digital processing algorithm; for example, to correct for the effective noise bandwidth for the filter type employed in the analyser that is important to measuring noise-like emissions from digitally modulated transmissions.

Errors of this type may be minimized or eliminated if a power ratio is measured, rather than absolute power, if the settings remain constant. This condition generally exists in those signal analysers equipped with an adjacent channel power ratio capability. This however applies only where the signal statistics of the occupied channel and the adjacent channel are the same (e.g. Gaussian).

For the adjacent channel and alternate adjacent channel power method, high selectivity channel filters may be used for the measurement of the adjacent channel power.

NOTE 1 – If the measurement bandwidth differs from the reference bandwidth, then for conversion of the results to the reference bandwidth a methodology is required.

NOTE 2 – When using a measurement bandwidth in the order of  $n\%$  of the occupied bandwidth, an overload factor depending on the signal type to be measured, should be taken into consideration. This overload factor will roughly be  $(10 \log (100/n) + 14)$  dB for noise-like emissions and can be up to  $20 \log (100/n)$  dB for impulsive emissions (e.g. for radar).

### 1.1.3 Video bandwidth

For peak power measurements the video bandwidth must be at least as large as the resolution bandwidth, and preferably be three to five times as large as the resolution bandwidth. For adjacent and alternate adjacent channel peak power measurements the combination of highly selective channel filters and peak detection may be used.

For mean power measurement the use of a narrow-bandwidth filter (e.g. 10 Hz) involves logarithmic mean averaging. This means the mean power resultant is lower than the actual power, the error magnitude depending on the signal statistics. Analysers with true mean power measurement function can avoid this type of error. For the adjacent and alternate adjacent channel methods the use of highly selective channel filters or an integration approach can avoid this type of error.

### 1.1.4 Sweep time

Using narrow-band resolution filters involves slow sweep times. In addition, r.m.s. weighting needs time for the averaging of noise-like signals and peak detection needs time until the highest peak occurs at each frequency, which may increase the required sweep time by a factor of 10 or more.

Assuming a resolution bandwidth  $B_{res}$  of 1% and a frequency span of 500% of the occupied bandwidth, the minimum sweep time  $T_{smin}$  will be approximately:

$$T_{smin} = 1\,000 (1/B_{res})$$

e.g. for an occupied bandwidth of 10 kHz a resolution bandwidth of 100 Hz will be equal to the reference bandwidth. Consequently the minimum sweep time will be  $T_{smin} = 10$  s.

The sweep and averaging times can considerably be reduced by using fast Fourier transform (FFT) techniques especially for narrow-band signals and by using channel filters for direct power measurements in adjacent or alternate adjacent filters.

For deterministic impulsive signals (e.g. radar) at least one cycle time  $T_c$  has to be taken per measurement if synchronization between measurement and radar pulses occur. Assuming 500 measurements the minimum sweep or scan time  $T_{smin} = 500 T_c$ . If synchronization does not occur, the minimum sweep or scan time will have to be multiplied by a factor of 2.



## 1.2 Coupling device

Measurements are made using a directional coupler capable of handling the power of the fundamental emission as illustrated in Fig. 48. To assure attainment of the proper measurement result it is necessary that this coupler present the proper impedance required for both states when switching between the signal generator and the transmitter under test.

## 1.3 Terminal load

To measure the power of OoB domain emissions, while using measurement Method 1 (see § 3), the transmitter should be connected to a test load or terminal load. The level of spurious domain emission depends on proper impedance matching between the transmitter, the transmission line and the test load.

## 1.4 Measuring antenna

Measurements are using Method 2 made with a tuned dipole antenna or a reference antenna with a known gain referenced to an isotropic antenna.

## 1.5 Conditions of modulation

The modulation conditions may be critical in assessing equipment performance, and should be the same for both in-band and OoB power measurements. Whenever it is possible, the measurements are made in the presence of the maximum rated modulation under normal operating conditions. Some examples follow.

### 1.5.1 Analogue voice modulation (e.g. A3E, F3E and J3E emission designators)

#### 1.5.1.1 Amplitude voice modulation (A3E, B8E, H3E, J3E and R3E emission designators)

Coloured Gaussian noise test signals may be employed in accordance with Recommendation ITU-R SM.328, Annex 1. Some additional suggestions concerning adjustment of the input signal levels can be found in Annexes 2 and 5 of the same Recommendation.

However, a number of current international standards (e.g. European Telecommunication Standards Institute (ETSI) ETS 300 373) use multiple tones for testing, as does Annex 9 (OoB domain emissions limits for the amateur services) of this Recommendation on OoB domain emission limits.

#### 1.5.1.2 Frequency voice modulation (F3E and P3E emission designators)

For transmitters using narrow-band phase or frequency modulation, a single modulation frequency of e.g. 1 kHz may be used.

### 1.5.2 Digital modulation (e.g. F1E, F7W, F9W, G1E, G7W, D7W emission designators)

A pseudo-random signal pattern such as that described in ITU-T Recommendation O.153 should be employed at the maximum modulation level. This may require the simultaneous employment of a set of multiple specific Walsh codes for code division multiple access transmitters.

### 1.5.3 Other modulations

This subject is under study.

### 1.5.4 Test input for multicarrier channels

In cases where an amplifier will be used to transmit multiple carriers, care must be taken to use an input to the system under test that adequately characterizes the OoB performance. In such a case, the OoB performance can be assessed using two unmodulated tones at the input of the transmitter as a

worst-case test. Both tones should be set to have a power level 6 dB below the peak envelope power of the transmitter. Other inputs can be used if deemed appropriate.

## 2 Measurement limitations

### 2.1 Measurement time limitations

For any desired signal, where the psd changes with time (e.g. non-constant envelope modulation), ten or more averaged measurements should be used for consistency.

### 2.2 Time division multiple access signals

For time division multiple access signals, the adjacent channel power will have to be measured during time slots using gated measurements. A distinction will have to be made between:

- continuous modulation spectra and wideband noise, where averaging over a number of time slots is usually required; and
- switching transients spectra where peak hold will be required (see e.g. ETSI EN 301 087).

## 3 Methods of measurement

### 3.1 Introduction

There are two methods for measurement of in-band and OoB emissions described in this Annex. Method 2 is described in the International Special Committee on Radio Interference (CISPR) Publication 16-2. Care must be taken with Methods 1 and 2 that emissions from the test do not cause interference to systems in the environment, nor receive interference from the environment impacting the results of the test and care must also be taken to utilize the appropriate weighting function (see § 1.1.1 above).

- Method 1 is the measurement of emission power supplied to the antenna port of the equipment under test (EUT). This method should be used whenever it is practical and appropriate.
- Method 2 is the measurement of the equivalent isotropic radiated power (e.i.r.p.), using a suitable test site.

NOTE 1 – CISPR publication 16-2 describes the measurement of the effective radiated power (e.r.p.) in the frequency range 30 MHz to 18 GHz. Since for e.r.p. a tuned half-wave dipole is used as the reference antenna instead of the isotropic antenna, the e.r.p. is 2.1 dB lower than the e.i.r.p.

In most cases the radiated OoB emission measurements can be simplified to relative measurements, which do not require calibrated receiving antennas and the determination of the e.i.r.p. Care must however be taken when considering the use of active receiving antennas, since harmonics or intermodulation products might be generated at higher field strengths.

VLF/LF band transmitters should be measured using Method 2 since the boundary between the transmitter, feeder cable and antenna is not always clearly defined.

Method 2 can normally not be applied as an e.i.r.p. measurement in the frequency range below 30 MHz, since substitution antennas (such as tuned half-wave dipoles) do not exist. In most cases OoB domain emission measurements are relative measurements, they can be made in the near field. Moreover there is no need for *in situ* field-strength measurements for systems below 30 MHz, since transmitters and antenna systems are frequently from different

manufacturers. Measurements at the antenna port are generally acceptable and provide transmitter manufacturers with a means of meeting OoB emission limits.

### 3.2 Method 1 – Measurement of the in-band and OoB emission power supplied to the antenna port

No particular test site or anechoic chamber is required and electromagnetic interferences should not affect the results of the tests. Whenever it is possible, the measurement should include the feeder cable. This method does not take into account attenuation due to antenna mismatch and radiation inefficiencies presented to any OoB domain emissions, or the active generation of OoB domain emissions by the antenna itself. The block-diagram of the measurement set-up for the OoB domain emission power to the antenna port is shown in Fig. 48.

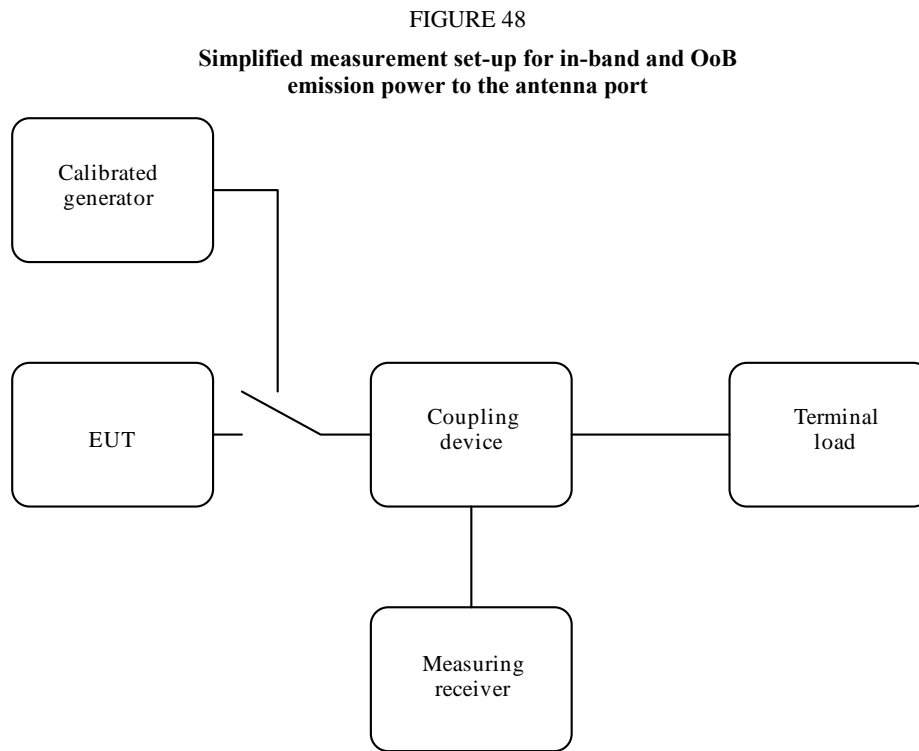

SM 15414R

#### 3.2.1 Direct conducted method

In this approach, it is required to calibrate all the measuring components individually (filter(s), coupler, cables), or to calibrate these connecting devices as a whole. In either case, the calibration is performed by using a calibrated adjustable level generator at the input of the measurement receiver. At each frequency,  $f$ , the calibration factor,  $k_f$ , is then determined as follows:

$$k_f = I_f - O_f$$

where:

$k_f$ : calibration factor at the frequency  $f$  (dB)

$I_f$ : input power (delivered by the calibrated generator) at the frequency  $f$  (dBW or dBm)

$O_f$ : output power (determined by the measurement receiver) at the frequency  $f$  (dBW or dBm).

This calibration factor represents the total insertion loss of all the devices connected between the generator and the measurement receiver.

If making individual device calibration measurements, calibration of the whole measurement set-up is derived by using the following formula:

$$k_{ms,f} = \sum_i k_{i,f}$$

where:

- $k_{ms,f}$ : calibration factor of the measurement set-up at the frequency  $f$  (dB)
- $k_{i,f}$ : individual calibration factor of each device in the measurement chain at the frequency  $f$  (dB).

During measurement of actual power levels,  $P_{r,f}$  (dBW or dBm) is the power (read on the measuring receiver) from the OoB domain emission at the frequency  $f$ , the OoB domain emission power  $P_{s,f}$  (same unit as  $P_{r,f}$ ) at the frequency,  $f$ , is calculated by using the following formula:

$$P_{s,f} = P_{r,f} + k_{ms,f}$$

### 3.2.2 Substitution method

This method does not require calibration of all measuring components. Instead, the output power is recorded from the measuring receiver. Then this power level is matched by a signal of the appropriate bandwidth from a calibrated signal generator which is substituted for the EUT. The power supplied by the generator is then equal to the power of the OoB domain emission.

### 3.2.3 Specific measurements

Methodology follows for modulation and intermodulation generated emissions.

#### 3.2.3.1 Occupied bandwidth

- Activate the transmitter into a matched load using the appropriate modulation condition (see § 1.5).
- Using a spectrum analyser coupled to measure the power into the load, display the emission psd characteristic for a span equal to 500% of the emission necessary bandwidth. In that bandwidth integrate the total emission power throughout the whole frequency span and designate the result as  $P_{REF}$ .  
NOTE 1 – The resolution bandwidth should be as close as possible to the reference bandwidth, but in any case be less than 5% of the occupied bandwidth if the measurement is to be used to verify an emission designator.
- Note the frequency above the emission centre frequency at which the total power above that frequency is generally equal to 0.5% of  $P_{REF}$ .
- Note the frequency below the emission centre frequency at which the total power below that frequency is generally equal to 0.5% of  $P_{REF}$ .

The difference between these frequencies is the occupied bandwidth measured for this emission.

### 3.2.3.2 OoB emissions due to modulation

FIGURE 49

Simplified method of measurement block diagram

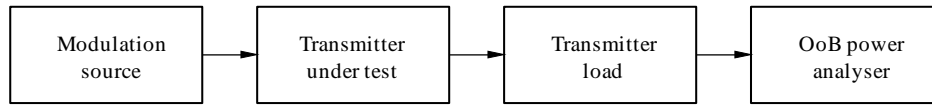
SM:15414<sup>6</sup>

- a) Connect the equipment as illustrated in Fig. 49. The transmitter is set to produce rated at the assigned frequency.
- b) The measurement bandwidth settings and markers of the analyser should be centred at the transmitter operating frequency, and simultaneously, at both the upper and lower adjacent band frequencies. The resolution and video bandwidths should be set appropriate to the bandwidth of the modulation.
- c) Activate the transmitter into a matched load using the appropriate modulation condition (see § 1.5).
- d) The power should be measured on the adjacent band power analyser in the transmitter authorized bandwidth, and should be recorded as  $P_{REF}$ .
- e) The power should then be measured on the adjacent band power analyser in the specified measurement bandwidth centred at both the upper and lower adjacent band frequencies. The lower frequency value should be recorded as  $P_{ADJL}$ , and the upper frequency value should be recorded as  $P_{ADJU}$ .
- f) Calculate the lower adjacent band power ratio,  $ABPR_L$ , as follows:

$$ABPR_L = P_{REF} - P_{ADJL}$$

- g) Calculate the upper adjacent channel power ratio,  $ABPR_U$ , as follows:

$$ABPR_U = P_{REF} - P_{ADJU}$$

- h) The adjacent band power ratio  $ABPR_1$  is the lesser of  $ABPR_L$  or  $ABPR_U$ .
- i) Repeat the above steps for the  $N$ -th adjacent band.

### 3.2.3.3 Measurement of the power spectral density

This measurement employs a spectrum analyser to simultaneously compare the psd of an emission with a set of limit line segments to verify that the emission does not exceed any limit at any given frequency in the measurement frequency range.

## 3.3 Method 2 – Measurement of the in-band and OoB e.i.r.p.

The block diagram of the measuring set-up for the OoB emission e.i.r.p. is shown in Fig. 50.

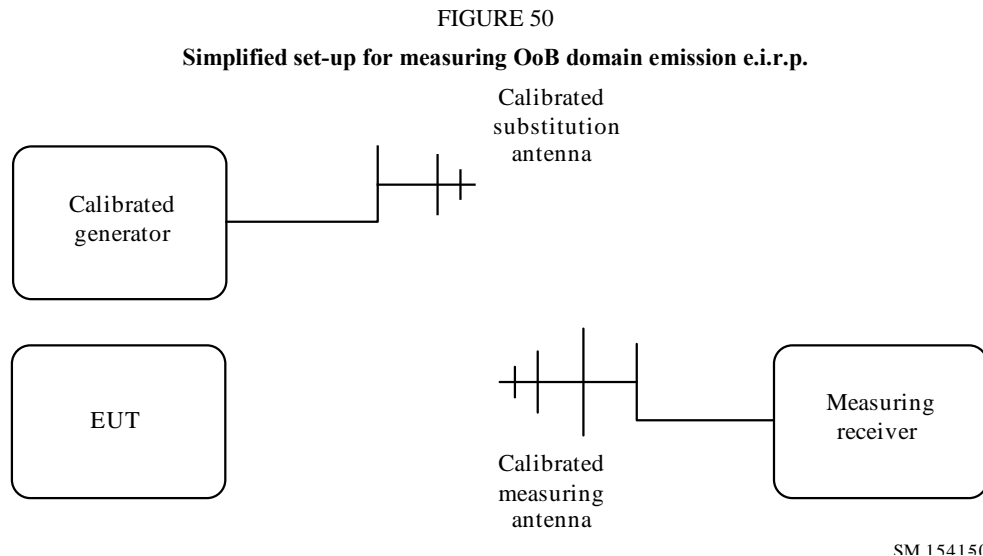

The OoB domain emission measurements may be made in the far field, but also in the near field, since in relatively narrow bands, the radiation conditions do not vary substantially and since only relative measurements have to be performed. The measurements of the e.i.r.p. of OoB domain emissions in any direction, in two polarizations and for any frequency could be very time consuming, although techniques to check compliance using relative measurements may reduce this workload. The use of this method to measure radars should be guided by Recommendation ITU-R M.1177.

### 3.3.1 Test sites for radiated emission measurements

#### 3.3.1.1 Test site for the frequency range below 30 MHz

Below about 30 MHz, usually *in-situ* measurements are conducted instead of measurements on a test site.

#### 3.3.1.2 Test site for radiated measurements in the frequency range 30 to 1 000 MHz

The test site is to be validated by making site attenuation measurements for both horizontal and vertical polarization fields as described in CISPR Publication 16-1:1999-10. A measurement site is to be considered acceptable if the horizontal and vertical site attenuation measurements are within  $\pm 4$  dB of the theoretical site attenuation.

The test site is to be characteristically flat, free of overhead wires and nearby reflecting structures, sufficiently large to permit antenna placement at the specified distance and provide adequate separation between antenna, EUT and reflecting structures. Reflecting structures are defined as those whose construction material is primarily conductive. The test site is to be provided with a horizontal metal ground-plane. Since for OoB domain emission, only relative measurements are made, the measurement task is substantially alleviated.

Tests may also be conducted in an absorber lined shielded room. In that case, the walls and the ceiling of a shielded room are covered with absorber materials that ensure low reflections of power. Validation measurements of such anechoic chambers are very important to ensure that the site attenuation measurements can be performed within the  $\pm 4$  dB criteria (see also International Electrotechnical Committee (IEC)/CISPR Publications 16-1 and 22).

A conducting ground-plane is to extend at least 1 m beyond the periphery of the EUT and the largest measuring antenna, and cover the entire area between the EUT and the antenna. It should be of metal with no holes or gaps, having dimensions larger than one-tenth of the wavelength at the highest frequency of measurement. A larger size conducting ground-plane may be required if the site

attenuation requirements of the test site are not satisfied. These requirements are also applicable in the case of semi-anechoic chambers.

Additional equipment is becoming available as the site for spurious domain emission measurements. These are various chambers, such as fully anechoic rooms (FAR), stirred mode chambers (SMC), and transverse electromagnetic (TEM) or Gigahertz TEM (GTEM) systems. The SMC is described in IEC/CISPR Publication 16-1. Drafts have been published (in autumn 2000) for IEC 61000-4-20 (TEM) and IEC 61000-4-21 (SMC).

### 3.3.1.3 Test site for the frequency range above 1 GHz

(See CISPR Publication 16-1:1999-10, validation requirements are under consideration.)

Tests may be made in a fully anechoic chamber. Reverberation chambers are also becoming available.

### 3.3.2 Direct method

In this approach, it is required to calibrate all the measuring components individually (filter(s), cables), or to calibrate the whole measuring set. See the direct approach in § 3.2.1 for the determination of the calibration factor of the measuring set at the frequency  $f$ .

The OoB domain emission e.i.r.p.,  $P_{s,f}$ , at the frequency  $f$ , is given for free space conditions by the following formula:

$$P_{s,f} = P_{r,f} + k_{ms,f} - G_f + 20 \log f + 20 \log d - 27.6$$

where:

- $P_{r,f}$ : power of the OoB domain emission read on the measuring receiver at the frequency  $f$  (dBW or dBm, same units as  $P_{s,f}$ )
- $k_{ms,f}$ : calibration factor of the measuring set-up at the frequency  $f$  (dB)
- $G_f$ : gain of the calibrated measuring antenna at the frequency  $f$  (dBi)
- $f$ : frequency of the OoB domain emission (MHz)
- $d$ : distance (m) between the transmitting antenna and the calibrated measuring antenna.

### 3.3.3 Substitution method

In this approach, a calibrated substitution antenna and a calibrated generator are used, the test source being adjusted for the same received OoB signal (see CISPR Publication 16-2:1996-11 for details).

## Annex 14

## Application of Recommendations ITU-R SM.1540 and ITU-R SM.1541

These generic OoB masks are intended to be applied both:

- outside the band assigned to the system whose OoB domain emissions are considered, but within the band allocated to the service in which the system considered operates; and
- within the adjacent allocated bands. Recommendation ITU-R SM.1540 provides guidance in the case of emissions that are very close to the edges of the total assigned band and that have OoB domain emissions falling into an adjacent band allocated to another service.

This is summarized in Fig. 51.

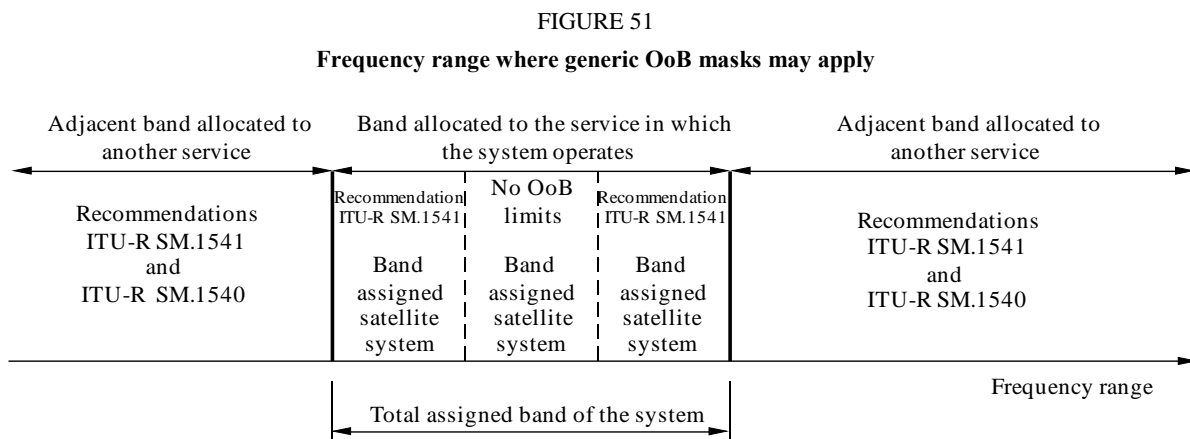

*Note 1* – This Recommendation on OoB domain emissions applies from the end of the total assigned band up to the beginning of the spurious domain.