

International Telecommunication Union

ITU-R
Radiocommunication Sector of ITU

Recommendation ITU-R SM.329-10
(02/2003)

Unwanted emissions in the spurious domain

SM Series
Spectrum management



Foreword

The role of the Radiocommunication Sector is to ensure the rational, equitable, efficient and economical use of the radio-frequency spectrum by all radiocommunication services, including satellite services, and carry out studies without limit of frequency range on the basis of which Recommendations are adopted.

The regulatory and policy functions of the Radiocommunication Sector are performed by World and Regional Radiocommunication Conferences and Radiocommunication Assemblies supported by Study Groups.

Policy on Intellectual Property Right (IPR)

ITU-R policy on IPR is described in the Common Patent Policy for ITU-T/ITU-R/ISO/IEC referenced in Annex 1 of Resolution ITU-R 1. Forms to be used for the submission of patent statements and licensing declarations by patent holders are available from <http://www.itu.int/ITU-R/go/patents/en> where the Guidelines for Implementation of the Common Patent Policy for ITU-T/ITU-R/ISO/IEC and the ITU-R patent information database can also be found.

Series of ITU-R Recommendations

(Also available online at <http://www.itu.int/publ/R-REC/en>)

Series	Title
BO	Satellite delivery
BR	Recording for production, archival and play-out; film for television
BS	Broadcasting service (sound)
BT	Broadcasting service (television)
F	Fixed service
M	Mobile, radiodetermination, amateur and related satellite services
P	Radiowave propagation
RA	Radio astronomy
RS	Remote sensing systems
S	Fixed-satellite service
SA	Space applications and meteorology
SF	Frequency sharing and coordination between fixed-satellite and fixed service systems
SM	Spectrum management
SNG	Satellite news gathering
TF	Time signals and frequency standards emissions
V	Vocabulary and related subjects

Note: This ITU-R Recommendation was approved in English under the procedure detailed in Resolution ITU-R 1.

Electronic Publication
Geneva, 2010

© ITU 2010

All rights reserved. No part of this publication may be reproduced, by any means whatsoever, without written permission of ITU.

RECOMMENDATION ITU-R SM.329-10

Unwanted emissions in the spurious domain*

(Question ITU-R 211/1)

(1951-1953-1956-1959-1963-1966-1970-1978-1982-1986-1990-1997-2000-2001-2003)

The ITU Radiocommunication Assembly,

considering

- a) that Recommendation ITU-R SM.328 gives definitions and explanatory notes which should be used when dealing with bandwidth, channel spacing and interference scenarios; when distinguishing between out-of-band emissions and spurious emissions; and when specifying limits for out-of-band domain emissions;
- b) that a difficulty faced in applying the limits for unwanted emissions in the spurious domain is knowing precisely the value of the necessary bandwidth and exactly where in the spectrum the limits for spurious domain should begin to apply, particularly for services using broadband or digitally-modulated emissions which may have both noise-like and discrete spurious components;
- c) that limitation of the maximum permitted level of spurious domain emissions¹ at the frequency, or frequencies, of each spurious domain emission is necessary to protect all radio services;
- d) that stringent limits may lead to an increase in size or in complexity of radio equipment, but will in general increase protection of other radio services from interference;
- e) that every effort should be made to keep limits for unwanted emissions in out-of-band and spurious domains, both for existing and new services, at the lowest possible values taking account of the type and nature of the radio services involved, economic factors, and technological limitations, and the difficulty of suppressing harmonic emissions from certain high power transmitters;
- f) that there is a need to define the methods, units of measurements and bandwidth, and the bandwidths to be used for measurement of power at frequencies other than the centre frequency. This will encourage the use of rational, simple, and effective means of reducing unwanted emissions;
- g) that the relation between the power of the spurious domain emission supplied to a transmitting antenna and the field strength of the corresponding signals, at locations remote from the transmitter, may differ greatly, due to such factors as antenna characteristics at the frequencies

* The limits in this Recommendation apply to any out-of-band or spurious emissions in the spurious domain. Spurious emissions are generally predominant in the spurious domain.

¹ Spurious domain emissions are unwanted emissions at frequencies within the spurious domain.

of the spurious domain emissions, propagation anomalies over various paths and radiation from parts of the transmitting apparatus other than the antenna itself;

h) that field-strength or pfd measurements of unwanted emissions, at locations distant from the transmitter, are recognized as the direct means of expressing the intensities of interfering signals due to such emissions;

j) that in dealing with emissions on the centre frequencies, administrations customarily establish the power supplied to the antenna transmission line, and may alternatively or in addition measure the field strength or pfd at a distance, to aid in determining when a spurious domain emission is causing interference with another authorized emission, and a similar, consistent procedure would be helpful in dealing with spurious domain emissions (see Article 15, No. 15.11 of the RR);

k) that for the most economical and efficient use of the frequency spectrum, it is necessary to establish general maximum limits of spurious domain emissions, while recognizing that specific services in certain frequency bands may need lower limits of spurious domain emissions from other services for technical and operational reasons as may be recommended in other ITU-R Recommendations (see Annex 4);

l) that transmitters operating in space stations are increasingly employing spread-spectrum and other broadband modulation techniques that can produce out-of-band and spurious emissions at frequencies far removed from the carrier frequency, and that such emissions may cause interference to passive services, including the radio astronomy service, recognizing however, that spectrum shaping techniques, which are widely used to increase the efficiency of spectral usage, result in an attenuation of side band emissions;

m) that spurious domain emission limits applicable to transmitters are a function of:

- the radiocommunication services involved and the minimum protection ratio determined in every frequency band;
- the type of environment where transmitters could be found (urban, suburban, rural, etc.);
- the type of transmitter;
- the minimum distance between the transmitter in question and the potential victim radio receiver;
- all possible decouplings between the antenna of the interfering transmitting antenna at the reception frequency and the receiving antenna of the radio receiver including the propagation model, polarization decoupling and other decoupling factors;
- the probability of occurrence of the spurious radiation of the transmitter when the receiver is active;
- the fact that a transmitter is active or idle, or that there are simultaneous active transmitters;

n) that some space stations have active antennas and the measurement of power as supplied to the antenna transmission line cannot cover emissions created within the antenna. For such space stations, the determination of field strength or pfd at a distance should be established by administrations to aid in determining when an emission is likely to cause interference to other authorized services;

- o) that spurious domain emissions may exist in the whole radio spectrum, but practical difficulties may dictate a frequency limit above which they need not to be measured;
- p) that Recommendation ITU-R SM.1539 deals with variation of the boundary between the out-of-band and spurious domains,

noting

- a) that the studies required by the new Question ITU-R 222/1, approved by the Radiocommunication Assembly 2000, could have formal and substantial impact to basic definitions used in this Recommendation. It may be necessary to revise this Recommendation in the future to reflect the results of these studies,

recommends

that the following should be used when spurious domain emission limits, and their methods of measurement, are applied:

1 Terminology and definitions

The following terms and definitions complement those already defined in the RR. (Definitions shown in *italics* are a direct quotation from the RR for completeness.)

1.1 Spurious emission (RR Article 1, No. 1.145)

Emission on a frequency, or frequencies, which are outside the necessary bandwidth and the level of which may be reduced without affecting the corresponding transmission of information. Spurious emissions include harmonic emissions, parasitic emissions, intermodulation products and frequency conversion products but exclude out-of-band emissions.

1.1.1 Harmonic emissions

Spurious emissions at frequencies which are whole multiples of the centre frequency emissions.

1.1.2 Parasitic emissions

Spurious emissions, accidentally generated at frequencies which are independent both of the carrier or characteristic frequency of an emission and of frequencies of oscillations resulting from the generation of the carrier or characteristic frequency.

1.1.3 Intermodulation products

Spurious intermodulation products result from intermodulation between:

- the oscillations at the carrier, characteristic, or harmonic frequencies of an emission, or the oscillations resulting from the generation of the carrier or characteristic frequency; and
- oscillations of the same nature, of one or several other emissions, originating from the same transmitting system or from other transmitters or transmitting systems.

1.1.4 Frequency conversion products

Spurious emissions, not including harmonic emissions, at the frequencies, or whole multiples thereof, or sums and differences of multiples thereof, of any oscillations generated to produce the carrier or characteristic frequency of an emission.

1.1.5 Broadband and narrow-band emission with respect to the measurement apparatus

A broadband emission is an emission which has “a bandwidth greater than a particular measuring apparatus or receiver” (see the International Electrotechnical Vocabulary (IEV)/International Electrotechnical Commission (IEC) 161-06-11).

A narrow-band emission is an emission which has “a bandwidth less than a particular measuring apparatus or receiver” (see IEV/IEC, 161-06-13).

1.2 Out-of-band emission (RR Article 1, No. 1.144)

Emission on a frequency or frequencies immediately outside the necessary bandwidth which results from the modulation process, but excluding spurious emissions.

1.3 Unwanted emissions (RR Article 1, No. 1.146)

Consist of spurious emissions and out-of-band emissions.

1.3bis Out-of-band domain²

(of an emission): The frequency range, immediately outside the necessary bandwidth but excluding the *spurious domain*, in which *out-of-band emissions* generally predominate.

NOTE 1 – Out-of-band *emissions*, defined based on their source, occur in the out-of-band domain and, to a lesser extent, in the spurious domain. Spurious emissions likewise may occur in the out-of-band domain as well as in the spurious domain.

1.3ter Spurious domain²

(of an emission): The frequency range beyond the *out-of-band domain* in which *spurious emissions* generally predominate.

1.4 Necessary bandwidth (RR Article 1, No. 1.152)

For a given class of emission, the width of the frequency band which is just sufficient to ensure the transmission of information at the rate and with the quality required under specified conditions.

For application to multi-channel or multi-carrier transmitters/transponders, where several carriers may be transmitted simultaneously from a final output amplifier or an active antenna, the necessary bandwidth is taken to be the transmitter or transponder bandwidth, as its 3 dB bandwidth. This does not apply to base stations in the mobile service or to fixed wireless access base stations using mobile technology.

² The terms “out-of-band domain” and “spurious domain” have been introduced in order to remove some inconsistency now existing between, on one hand, the definitions of the terms “out-of-band emission” and “spurious emission” in RR Article 1 and, on the other hand, the actual use of these terms in RR Appendix 3, as revised by the World Radiocommunication Conference (Istanbul, 2000) (WRC-2000). Out-of-band domain emission and spurious domain emission limits apply, respectively, to all unwanted emissions in the out-of-band and spurious domains.

For fixed service, Recommendation ITU-R F.1191 is to be used to calculate the necessary bandwidth in the case of fixed digital radio multi-carrier systems.

For the radiodetermination service, the necessary bandwidth of frequency-agile radars is taken to be the part of the allocated band over which the carrier frequencies of those radars tune.

1.5 Active state of a transmitter

That state of a transmission station which produces the authorized emission.

1.6 Idle or standby state of a transmitter

That state of a transmission station where the transmitter is available for traffic but is not in active state.

Primary radars are not considered to operate in a standby state since the transmitter is in an active state during operation. Also, pulsed radar systems are not considered to be in the standby state during their interpulse intervals. Neither are time division communication systems to be considered to be in the idle or standby state in the interval between time slots.

2 Application of limits

2.1 The levels of spurious domain emissions could be expressed in terms of the peak envelope power or in terms of the mean power supplied by the transmitter to the antenna feeder line at the frequencies of the emission concerned, within a defined reference bandwidth, depending on the nature of the radio service of the transmitter.

2.2 Alternatively the levels of spurious domain emissions could be expressed in terms of the field strength or pfd on the surface of the Earth, at the frequencies of the spurious domain emission concerned.

2.3 According to the principles stated in Appendix 3 to the RR, the spurious domain generally consists of frequencies separated from the centre frequency of the emission by 250% or more of the necessary bandwidth of the emission. However, this frequency separation may be dependent on the type of modulation used, the maximum bit rate in the case of digital modulation, the type of transmitter, and frequency coordination factors. For example, in the case of some digital, broadband or pulse-modulated systems, the frequency separation may need to differ from the $\pm 250\%$ factor. As the RR forbid any radio service to cause harmful interference outside its allocated band, transmitter frequencies should be determined so that out-of-band emissions do not cause harmful interference outside the allocated band in accordance with RR No. 4.5.

Alternatively, the $\pm 250\%$ may apply to channel separation instead of the necessary bandwidth. As an example, for frequency coordination of the digital fixed service, Recommendation ITU-R F.1191 recommends the use of $\pm 250\%$ of the channel separation of the relevant radio-frequency channel arrangement as frequency boundaries between the out-of-band and spurious domains.

In case of very narrow or wide bandwidth, this method of determining the spurious domain might not be appropriate and Recommendation ITU-R SM.1539 provides further guidance.

Additional guidance concerning the necessary bandwidth required for determining the boundary between the out-of-band and spurious domains can be found in *recommends* 2.3 of Recommendation ITU-R SM.1541.

2.4 Where a transmitting system comprises more than one transmitter connected to the same antenna the limits specified in § 3 should apply, as far as practicable, to the intermodulation products related to the use of several transmitters.

2.5 Limits on spurious domain emissions for radio equipments are considered here to be applicable to the range 9 kHz to 300 GHz.

However, for practical measurement purposes only, the frequency range of the spurious domain may be restricted. As guidance for practical purposes, the following frequency ranges of measurement, as given in Table 1, are normally recommended.

TABLE 1

Frequency range for measurement of unwanted emissions

Fundamental frequency range	Frequency range for measurements	
	Lower limit	Upper limit (The test should include the entire harmonic band and not be truncated at the precise upper frequency limit stated)
9 kHz-100 MHz	9 kHz	1 GHz
100 MHz-300 MHz	9 kHz	10th harmonic
300 MHz-600 MHz	30 MHz	3 GHz
600 MHz-5.2 GHz	30 MHz	5th harmonic
5.2 GHz-13 GHz	30 MHz	26 GHz
13 GHz-150 GHz	30 MHz	2nd harmonic
150 GHz-300 GHz	30 MHz	300 GHz

There will be cases where it is necessary, in order to protect specific services, to extend the range of test frequencies to the 3rd or higher harmonic for systems with fundamental frequency above 13 GHz. The parameters in Table 1 reflect the increasing practical difficulty of conducting tests by extending upwards in frequency the conventional microwave measurement techniques described in Annex 2 to frequencies above 110 GHz. At such frequencies and higher, it may be more practicable to adopt bolometric measurement techniques used at infra-red frequencies. For example, for vehicular radars at 76-77 GHz, it is appropriate that the 3rd harmonic be measured, around 220 GHz, and here, conventional microwave test methods are probably inappropriate.

In any case, systems having an integral antenna incorporating a waveguide section, or with an antenna connection in such form, and of unperturbed length equal to at least twice the cut-off wavelength, do not require spurious domain emission measurements below 0.7 times the waveguide cut-off frequency.

2.6 Spurious domain emission from any part of the installation, other than the antenna system (the antenna and its feeder) should not have an effect greater than would occur if this antenna system were supplied with the maximum permissible power at that spurious domain frequency.

2.7 Transient emissions caused by switching in time division multiple access (TDMA) systems should, where possible meet the spurious domain emission suppression requirement.

3 Limits of spurious domain emissions

3.1 The limits should improve the operation of radiocommunication services in all bands.

3.2 The different units for expressing spurious domain emission and the conversion Table given in Annex 1 should be used.

3.3 The definition of the categories of spurious domain emission limits are shown below, including RR Appendix 3 limits, examples of more stringent limits and limits applying to information technology equipment (ITE).

Category A	Category A limits are the attenuation values used to calculate maximum permitted spurious domain emission power levels. RR Appendix 3 is derived from Category A limits. These limits are given in § 4.2.
Category B	Category B limits are an example of more stringent spurious domain emission limits than Category A limits. They are based on limits defined and adopted in Europe and used by some other countries. These limits are given in § 4.3.
Category C	Category C limits are an example of more stringent spurious domain emission limits than Category A limits. They are based on limits defined and adopted in the United States of America and Canada and used by some other countries. These limits are given in § 4.4.
Category D	Category D limits are an example of more stringent spurious domain emission limits than Category A limits. They are based on limits defined and adopted in Japan and used by some other countries. These limits are given in § 4.5.
Category Z	Radiation limits for ITE specified by the International Special Committee on Radio Interference (CISPR). These limits are given in § 4.6.

NOTE 1 – Category B, C and D limits are more stringent than Category A limits and each represents a compromise between lower unwanted emissions and the cost of equipment. Currently, all are successfully used as national or regional regulations including in areas having a high radiocommunication density and using equipment representing a significant portion of the radiocommunications manufacturing base.

Tables of emission limits (see *recommends* 4) represent recommended limits for each of these categories by frequency band and type of transmitters for the protection of all radiocommunication services.

4 Tables of emission limits

4.1 Recommended reference bandwidths

A reference bandwidth is a bandwidth in which spurious domain emission levels are specified. The following reference bandwidths are recommended:

- 1 kHz between 9 and 150 kHz,
- 10 kHz between 150 kHz and 30 MHz,
- 100 kHz between 30 MHz and 1 GHz,
- 1 MHz above 1 GHz.

As a special case, the reference bandwidth of all space service spurious domain emissions should be 4 kHz.

For Category B limits, narrower reference bandwidth are specified close to the carrier for fixed and land mobile services.

The reference bandwidths required for proper measurement of radar spurious domain emissions must be calculated for each particular radar system, and the measurement methods should be guided by Recommendation ITU-R M.1177.

NOTE 1 – The reference bandwidth is a bandwidth in which the spurious domain emission limit is specified, but does not mean a bandwidth in which spurious domain emissions should be measured. Annex 2 describes the resolution bandwidth in which spurious domain emissions should be measured. As a general guideline, the resolution bandwidth should be equal to the reference bandwidth. However, to improve measurement accuracy, sensitivity and efficiency, the resolution bandwidth can be different from the reference bandwidth as described in Annex 2.

4.2 Category A limits

Table 2 indicates the maximum permitted levels of spurious domain emissions, appearing in RR Appendix 3, in terms of power of any unwanted component supplied by a transmitter to the antenna transmission line, except for space services which are currently shown as design limits; for the implementation date for the radiodetermination service; for deep space stations and for amateur stations. Some notes to Appendix 3 give specific direction on the application of the limits.

Spurious domain emission from any part of the installation other than the antenna and its transmission line should not have an effect greater than would occur if this antenna system were supplied with the maximum permitted power at that spurious domain emission frequency.

For technical or operational reasons, more stringent levels than those specified in Table 2 may be applied to protect specific services in certain frequency bands. The levels applied to protect these services should be those agreed upon by the appropriate WRC. More stringent levels may also be fixed by specific agreements between the administrations concerned. Additionally, special consideration of transmitter spurious domain emissions is required for protection of radio astronomy and other passive services.

Sample calculations and Category A maximum absolute spurious domain power levels, derived from Table 2 values, can be found in Annex 5.

TABLE 2

Spurious domain emission limits – Category A

(Recommended attenuation values used to calculate maximum permitted spurious domain emission power levels intended for use with radio equipment by all countries)

Service category in accordance with RR Article 1, or equipment type ^{(1), (2)}	Attenuation (dB) below the power (W) supplied to the antenna transmission line
All services except those services quoted below	43 + 10 log P , or 70 dBc, whichever is less stringent
Space services (mobile earth stations) ^{(3), (4)}	43 + 10 log P , or 60 dBc, whichever is less stringent
Space services (fixed earth stations) ^{(3), (4)}	43 + 10 log P , or 60 dBc, whichever is less stringent
Space services (space stations) ^{(3), (5), (6)}	43 + 10 log P , or 60 dBc, whichever is less stringent
Radiodetermination ⁽⁷⁾	43 + 10 log PEP , or 60 dB, whichever is less stringent
Broadcast television ⁽⁸⁾	46 + 10 log P , or 60 dBc, whichever is less stringent, without exceeding the absolute mean power level of 1 mW for VHF stations or 12 mW for UHF stations. However greater attenuation may be necessary on a case-by-case basis
Broadcast FM	46 + 10 log P , or 70 dBc, whichever is less stringent; the absolute mean power level of 1 mW should not be exceeded
Broadcasting at MF/HF	50 dBc and the absolute mean power level of 50 mW should not be exceeded
SSB from mobile stations ⁽⁹⁾	43 dB below PEP
Amateur services operating below 30 MHz (including with SSB) ⁽⁹⁾	43 + 10 log PEP , or 50 dB, whichever is less stringent
Services operating below 30 MHz, except space, radiodetermination, broadcast, those using SSB from mobile stations, and amateur ⁽⁹⁾	43 + 10 log X , or 60 dBc, whichever is less stringent where: $X = PEP$ for SSB modulation, $X = P$ for other modulation
Low power device radio equipment ⁽¹⁰⁾	56 + 10 log P , or 40 dBc, whichever is less stringent
Emergency position-indicating radio beacon (EPIRB), emergency locator transmitter (ELT), personal location beacon (PLB), search and rescue transponder (SART), ship emergency, lifeboat, and survival craft transmitters, land, aeronautical or maritime transmitters when used in emergency	No limit

Notes to Table 2:

P: mean power (W) at the antenna transmission line, in accordance with RR No. 1.158. When burst transmission is used, the mean power *P* and the mean power of any spurious domain emissions are measured using power averaging over the burst duration.

PEP: peak envelope power (W) at the antenna transmission line, in accordance with RR No. 1.157.

When the term *P* is used, both the power supplied to the antenna transmission line and spurious domain emissions should be evaluated in terms of mean power and mean power in the reference bandwidth respectively. When the term *PEP* is used, both the power supplied to the antenna transmission line and spurious domain emissions should be evaluated in terms of peak envelope power and peak envelope power in the reference bandwidth respectively. However, when measurement of spurious domain emission in terms of *PEP* is difficult due to the nature of spurious domain emission (e.g. Gaussian noise), it is allowed to evaluate both power supplied to the antenna transmission line and spurious domain emission power in terms of mean power (see Annex 2).

dBc: decibels relative to the unmodulated carrier power of the emission. In the cases which do not have a carrier, for example in some digital modulation schemes where the carrier is not accessible for measurement, the reference level equivalent to *dBc* is decibels relative to the mean power *P*.

- (1) In some cases of digital modulation and narrow-band high power transmitters for all categories of services, there may be difficulties in meeting limits close to $\pm 250\%$ of the necessary bandwidth.
- (2) Use the e.i.r.p. method shown in Annex 2, § 3.3, when it is not practical to access the transition between the transmitter and the antenna transmission line.
- (3) Spurious domain emission limits for all space services are stated in a 4 kHz reference bandwidth.
- (4) Earth stations in the amateur-satellite service operating below 30 MHz are in the service category "Amateur services operating below 30 MHz (including with SSB)".
- (5) For the case of a single satellite operating with more than one transponder in the same service area, and when considering the limits for spurious domain emissions as indicated in Table 2, spurious domain emissions from one transponder may fall on a frequency at which a second, companion transponder is transmitting. In these situations, the level of spurious domain emissions from the first transponder is well exceeded by the fundamental or out-of-band domain emissions of the second transponder. Therefore, the limits should not apply to those spurious domain emissions of a satellite that fall within either the necessary bandwidth or the out-of-band domain of another transponder on the same satellite, in the same service area (see RR Appendix 3).
- (6) Space stations in the space research service intended for operation in deep space as defined by RR No. 1.177 are exempt from spurious domain emission limits.
- (7) For radiodetermination systems (radar as defined by RR No. 1.100), spurious domain emission attenuation (dB) shall be determined for radiated emission levels, and not at the antenna transmission line. The measurement method for determining the radiated spurious domain emission levels from radar systems should be guided by Recommendation ITU-R M.1177.
- (8) For analogue television transmissions, the mean power level is defined with a specified video signal modulation. This video signal has to be chosen in such a way that the maximum mean power level (e.g., at the video signal blanking level for negatively modulated television signals) is provided to the antenna transmission line.

Notes to Table 2 (continued):

- (9) All classes of emission using SSB are included in the category “SSB”.
- (10) Low power radio device having a maximum output power of less than 100 mW and intended for short range communication or control purposes. (Such equipment is in general exempt from individual licensing.)

4.3 Category B limits

Table 3 indicates the maximum permitted levels of spurious domain emissions, in terms of power level, of any unwanted component supplied by a transmitter to the antenna transmission line for Category B equipment. For all services/systems not quoted in this Table, Category A limits are applicable.

TABLE 3
Category B limits
 (See definitions in *recommends 3.3*)

Type of equipment	Limits
Fixed service ^{(1), (2)}	-50 dBm for 30 MHz ≤ <i>f</i> < 21.2 GHz ⁽³⁾ -30 dBm for 21.2 GHz ≤ <i>f</i> < (see <i>recommends 2.5</i>) ⁽³⁾
Fixed service – Terminal station (out station with subscriber equipment interfaces) ⁽¹⁾	-40 dBm for 30 MHz ≤ <i>f</i> < 21.2 GHz ⁽³⁾ -30 dBm for 21.2 GHz ≤ <i>f</i> < (see <i>recommends 2.5</i>) ⁽³⁾
Land mobile service (mobiles and base stations)	-36 dBm for 9 kHz ≤ <i>f</i> < 30 MHz -36 dBm for 30 MHz ≤ <i>f</i> < 1 GHz ⁽⁴⁾ -30 dBm for 1 GHz ≤ <i>f</i> < (see <i>recommends 2.5</i>) ⁽⁴⁾
VSAT (very small aperture terminal)	See limits in Recommendation ITU-R S.726
FM broadcasting	87.5 MHz ≤ <i>f</i> ≤ 137 MHz: -36 dBm for <i>P</i> < 9 dBW 75 dBc for 9 dBW ≤ <i>P</i> < 29 dBW -16 dBm for 29 dBW ≤ <i>P</i> < 39 dBW 85 dBc for 39 dBW ≤ <i>P</i> < 50 dBW -5 dBm for 50 dBW ≤ <i>P</i> 30 MHz < <i>f</i> < 87.5 MHz and 137 MHz < <i>f</i> < (see <i>recommends 2.5</i>): -36 dBm for <i>P</i> < 4 dBW 70 dBc for 4 dBW ≤ <i>P</i> < 40 dBW 0 dBm for 40 dBW ≤ <i>P</i>
Radar systems in the radiodetermination service: Fixed radiodetermination stations ^{(5), (6), (7), (8)} (wind profiler, multifrequency and active array radars are excluded)	-30 dBm or 100 dB attenuation below the PEP, whichever is less stringent

TABLE 3 (end)

Type of equipment	Limits	
Short range devices operating below 30 MHz	29 – 10 log(f (kHz)/9) dB(μ A/m) at 10 m for 9 kHz < f < 10 MHz	
	–1 dB(μ A/m) at 10 m for 10 MHz < f < 30 MHz	
	–36 dBm	for 30 MHz \leq except frequencies below < 1 GHz
	–54 dBm	for f within the bands 47-74 MHz, 87.5-118 MHz, 174-230 MHz, 470-862 MHz
	–30 dBm	for 1 GHz $\leq f$ < (see <i>recommends 2.5</i>)
Short range device above 30 MHz, Radio local area networks, Citizens band (CB), cordless telephones, and radio microphones	–36 dBm	for 9 kHz \leq except frequencies below < 1 GHz
	–54 dBm	for f within the bands 47-74 MHz, 87.5-118 MHz, 174-230 MHz, 470-862 MHz
	–30 dBm	for 1 GHz $\leq f$ < (see <i>recommends 2.5</i>)

P : mean power (W) at the antenna transmission line, in accordance with RR No. 1.158. When burst transmission is used, the mean power, P and the mean power of any spurious domain emissions are measured using power averaging over the burst duration.

Spurious domain emissions should be evaluated in terms of mean power except for the radiodetermination service where spurious domain emission should be evaluated in terms of PEP. However, when measurement of spurious domain emission in terms of PEP is difficult due to the nature of spurious domain emission (e.g. Gaussian noise), it is allowed to evaluate both power supplied to the antenna transmission line and spurious domain emission power in terms of mean power (see Annex 2).

f : frequency of the spurious domain emissions.

- (1) Fixed wireless access (FWA) systems using cellular type mobile technologies, described in Recommendation ITU-R F.757, when administrations allows their usage in the same bands locally assigned to land mobile systems or to FWA using a specific land mobile technology, should be subjected to the land mobile service spurious domain emission limits.
- (2) Category A limits apply to HF fixed service.
- (3) A reduced reference bandwidth is allowed on both sides of the emission from 250% of the necessary bandwidth (see Annex 6).
- (4) A reduced reference bandwidth is allowed on both sides of the emission from 250% of the necessary bandwidth (see Annex 7).
- (5) For radiodetermination systems (radar as defined by RR No. 1.100), spurious domain emission attenuation (dB) shall be determined for radiated emission levels, and not at the antenna transmission line. The measurement method for determining the radiated spurious domain emission levels from radar systems should be guided by Recommendation ITU-R M.1177.
- (6) European and some other countries have determined that insofar as they are concerned, Category B spurious domain emission limits for radar systems should apply to transmitters used in those countries and installed after 1 January 2006.
- (7) On a site-by-site basis, administrations may permit the use of maritime mobile radar equipment in fixed installations (e.g. vessel traffic services radar), using the appropriate limits for mobile radars.
- (8) Further study is to be undertaken by the relevant regional body, any interference will be handled on a case-by-case basis.

4.4 Category C limits

Table 4 indicates the maximum permitted levels of spurious domain emissions, in terms of power level, of any spurious component supplied by a transmitter to the antenna transmission line for Category C equipment. For all services/systems not quoted in this Table, Category A limits are applicable.

TABLE 4

Category C limits

(See definitions in *recommends* 3.3)

Type of equipment	Attenuation below the power supplied to the antenna transmission line ⁽¹⁾
Land mobile service (150-174 MHz and 421-512 MHz)	50 + 10 log P or 70 dBc for 12.5 kHz channels, whichever is less stringent 55 + 10 log P or 65 dBc for 6.5 kHz channels, whichever is less stringent
Aeronautical telemetry ⁽²⁾	55 + 10 log P
HF broadcasting	80 dBc
AM and FM broadcasting	43 + 10 log P or 80 dBc, whichever is less stringent
Non-GSO mobile earth terminals (mobile-satellite service, 1 610-1 660.5 MHz (limits apply to spurious domain emissions in the 1 559-1 605 MHz band)) ⁽³⁾	-70 dB(W/MHz) e.i.r.p., and -80 dBW e.i.r.p. in any 300 Hz bandwidth

P : mean power (W) at the antenna transmission line, in accordance with RR No. 1.158. When burst transmission is used, the mean power P and the mean power of any spurious domain emissions are measured using power averaging over the burst duration.

- (1) For mobile earth terminals, the limits shown represent absolute e.i.r.p. levels rather than attenuation.
 (2) As a special case, the reference bandwidth should be 3 kHz.
 (3) Proposed.

4.5 Category D limits

Table 5 indicates the maximum permitted levels of spurious domain emissions, in terms of power level, of any unwanted component supplied by a transmitter to the antenna transmission line for Category D equipment. For all services/systems and output power range not quoted in the Table, Category A limits are applicable.

TABLE 5

Category D Limits

(See definitions in *recommends* 3.3)

Type of equipment	Limits
Fixed service 30 MHz < f_0 ≤ 335.4 MHz 335.4 MHz < f_0 ≤ 470 MHz	60 dBc for $P < 50$ W 0 dBm for $10 \text{ kW} \leq P$ -26 dBm for $P < 25$ W 70 dBc for $25 \text{ W} \leq P < 10 \text{ kW}$ 0 dBm for $10 \text{ kW} \leq P$
Maritime mobile service ⁽¹⁾ 30 MHz < f_0 ≤ 335.4 MHz	146 MHz < f ≤ 162.0375 MHz -26 dBm for $P < 20$ W 69 dBc for $20 \text{ W} \leq P < 400 \text{ W}$ $f \leq 146 \text{ MHz}$ and $162.0375 \text{ MHz} < f$ -20 dBm for $P < 20$ W 63 dBc for $20 \text{ W} \leq P < 100 \text{ W}$
Aeronautical mobile service ⁽²⁾ 118 MHz < f_0 ≤ 142 MHz 335.4 MHz < f_0 ≤ 470 MHz 830 MHz < f_0 ≤ 887 MHz ⁽²⁾	-16 dBm for $P \leq 25$ W 60 dBc for $P < 50$ W 0 dBm for $10 \text{ kW} \leq P$ -26 dBm for $P \leq 25$ W 70 dBc for $25 \text{ W} < P$
SSB (Fixed and land stations excluding coast stations) $f_0 \leq 30$ MHz	50 dBc for $P < 5$ W
Land mobile service (Analogue systems for portable/auto-mobile telephones) (Digital cordless telephones and PHS) 1 893.65 MHz < f_0 ≤ 1 919.45 MHz	60 dBc for $P < 50$ W 1 893.5 MHz < f ≤ 1 919.6 MHz -36 dBm $f \leq 1 893.5 \text{ MHz}$ and $1 919.6 \text{ MHz} < f$ -26 dBm

P : mean power (W) at the antenna transmission line, in accordance with RR No. 1.158. When burst transmission is used, the mean power P and the mean power of any spurious domain emissions are measured using power averaging over the burst duration

f : frequency of the spurious domain emissions

f_0 : fundamental frequency.

(1) For F3E emission and for ship stations or on-board communication stations.

(2) For aircraft radiotelephony.

4.6 Category Z limits

Table 6 contains Category Z limits for Class A (industrial) and B (domestic) ITE. Category Z equipment is defined as that which combines ITE with a radio transmitting function. If the information technology portion can be detached and still operate independently, then each part should be tested separately in conformity with the pertinent ITU-R spurious domain emission limit or the CISPR limit. If the information technology portion cannot be independently operated, then the ITU-R Category A, B, C or D limits should be applied while testing in the transmitting mode and the CISPR limits should apply in the standby or idle mode. Values are taken from CISPR Publication No. 22 for frequencies below 1 GHz. Limits for frequencies above 1 GHz are under consideration within CISPR.

TABLE 6

Category Z limits

(Radiation limits for ITE specified by CISPR)

Frequency (MHz)	E_{max} (dB(μ V/m))	Distance of measurement (m)	Corresponding e.i.r.p. (dBm)
Class A: applicable to ITE intended for industrial environment			
30-230	40	10	-49
230-1 000	47	10	-42
Class B: applicable to ITE intended for a domestic environment			
30-230	30	10	-59
230-1 000	37	10	-52

Conversion in terms of e.i.r.p. is provided for information by assuming that the maximum field strength is to be measured in a semi-anechoic chamber or in an open area test site according to the CISPR measurement method. This is approximately 4 dB above a measurement with free-space condition (this value is in agreement with CISPR studies).

5 Measurement method

The measurement methods of spurious domain emissions are described in detail in Annex 2.

6 Protection of radio astronomy service and space services using passive sensors

Protection criteria for the radio astronomy service and Earth exploration-satellite and meteorological satellite services using passive sensors should be taken into account when applying spurious domain emission limits. All of these services can be particularly sensitive to interference.

6.1 Radio astronomy service

Radio astronomy, because of its passive nature and because of the sensitivity of its measurements, needs special consideration as far as spurious domain emissions are concerned; radio astronomers routinely encounter signal-to-noise ratios of -30 to -60 dB using long integration intervals. Administrations are urged, as far as practicable, to take into consideration the need to avoid spurious domain emissions which could cause interference to radio astronomy operating in accordance with RR Article 29. In bringing new satellite services into operation, administrations are urged to note that transmitters on satellites can cause severe interference to radio astronomy through their spurious and out-of-band emissions, including far sidebands which result from digital modulation techniques. The threshold levels of interference for radio astronomy as given in Recommendation ITU-R RA.769 should be taken into account. An extract from the Table of Recommendation ITU-R RA.769 is contained in Annex 3. The levels in this Table are listed for reference and are not intended for general application as mandatory limits.

For transmitters on the Earth's surface, if limits on unwanted emissions do not afford sufficient protection for radio astronomy, mitigation of interference can, in some cases, be provided, for example, through terrain shielding; by the establishment by administrations of coordination, protection or exclusion zones; and by other provisions of RR Articles 15 and 29 relative to radio astronomy observatories.

6.2 Earth exploration-satellite and meteorological satellite services using passive sensors

Passive remote sensing from satellites is becoming increasingly important for the retrieval of atmospheric parameters including temperature, water vapour content, concentration of ozone and other gases, as well as examination of the surface of the Earth. Recommendation ITU-R SA.1029 contains the threshold levels of interference for satellite passive remote sensing. An extract from Recommendation ITU-R SA.1029 is contained in Annex 3. The levels contained in this table are for reference and are not intended as mandatory limits.

Annex 1

Expression and units for spurious domain emissions

1 Expression of spurious domain emissions

Spurious domain emissions levels are generally expressed in terms of power, field strength measured at a given distance, or a pfd also measured at a given distance, all measured in a given bandwidth.

Even if the field strength at a given distance from the transmitting antenna is the more significant value to assess and measure spurious domain emissions, it is considered sufficient for a while, to identify the power parameters of the transmitters in order to work on radio interference and electromagnetic compatibility.

1.1 Power values

Many expressions related to the radiated power are useful to evaluate spurious domain emissions. They all present advantages and difficulties, linked to current measurement capabilities as well as to the interpretation of the measured values.

1.1.1 Power supplied to the antenna (p.s.a.)

Often used below 30 MHz and for equipment above 30 MHz having an antenna connector, this power is generally easy to measure except when a transmitter has an integral antenna or for high powered ELF/LF systems.

This power measurement represents the actual capability of the transmitter to feed an antenna with spurious signals, but does not take account of the antenna itself and its capability to radiate radio emissions at frequencies other than those for which it has been designed.

1.1.2 Equivalent isotropic radiated power (e.i.r.p.)

Mainly used above 30 MHz (most of the time above 80 MHz), this power gives a better knowledge of the capability of the transmitter system (including the antenna) to radiate the power of unwanted emissions and to possibly produce harmful interference to other radio services. The relation between the power at the antenna port or connector and the e.i.r.p. is not easy to derive, as the characteristics of antennas outside their design band are generally not known.

For equipment having integral antennas, it is the main known power parameter which characterizes spurious domain emissions.

1.1.3 Effective radiated power (e.r.p.)

The only difference from e.i.r.p. is that e.r.p. refers to the radiation of a half wave tuned dipole instead of an isotropic antenna. There is a constant difference of 2.15 dB between e.i.r.p. and e.r.p.

$$e.i.r.p. \text{ (dBm)} = e.r.p. \text{ (dBm)} + 2.15$$

1.2 Field strength

The interfering field strength, E or H , at the victim receiver antenna is, in principle, the required characteristic for the spurious domain emission effect to be known. The relation, however, between the e.i.r.p. and the field strength in all possible situations is quite difficult to determine, because of radiowave propagation and other radio coupling phenomena (diffraction from buildings, effects of masks etc.), even if the derivation of spurious domain emission limits take into account only some basic/worst-case situations that can occur.

Field strength is a value that is usually measured on a test site, at a given distance. For disturbance and interference measurement purposes of non intentionally radiating devices and particularly ITE, CISPR recommends typical field-strength measurements at 10 m on a calibrated open area test site (OATS) with a reflecting ground plane.

1.3 pfd

pfd is generally evaluated and measured above 1 GHz, for satellite radio links, and radio astronomy.

2 Units

2.1 Power units

Even though the International System (IS) power unit is the Watt (W), the telecommunication publications express spurious domain emissions p.s.a., e.i.r.p. or e.r.p. in various units including dBpW, nW, dBm or dBW or equivalent expressions of power density per any reference bandwidth.

2.2 Field strength units

The electric field strength unit, E , is the V/m. Most of the telecommunication publications express electric field strength in $\mu\text{V/m}$ or $\text{dB}(\mu\text{V/m})$.

The magnetic field strength unit, H , is the A/m. Most of the telecommunication publications express electric field strength in $\mu\text{A/m}$ or $\text{dB}(\mu\text{A/m})$.

2.3 pfd units

The pfd unit is the W/m^2 . Most of the telecommunication publications express pfd in $\text{dB}(\text{W/m}^2)$ or in mW/cm^2 .

3 Relation between power, electric field strength, E , and pfd

A simple relation can be established for perfect, ideal cases (which means free space, far field conditions) between E (V/m), D distance between the transmitting radio equipment and the point of measurement (m), e.i.r.p. (W) and pfd (W/m^2).

$$E = \frac{\sqrt{30 (e.i.r.p.)}}{D}$$

A maximum value of E can be calculated, representing the maximum reading obtainable on an OATS by adjustment of the measurement antenna height. It is:

$$E_{max} \cong 1.6 E$$

This represents a site gain of 4 dB. The field strength as E (V/m) can be converted to $\text{dB}(\mu\text{V/m})$ as follows:

$$E (\text{dB}(\mu\text{V/m})) = 120 + 20 \log E$$

the pfd (W/m^2) is:

$$pfd = E^2/(120\pi)$$

and the pfd ($\text{dB}(\text{W/m}^2)$) is:

$$pfd = 10 \log pfd$$

Table 7 shows the correspondence between the power values (e.i.r.p., e.r.p.), the field strength (E , E_{max}) and the pfd for different units.

TABLE 7

Correspondence between e.i.r.p., e.r.p., field strength, E , and pfd

e.i.r.p. (dBm)	e.i.r.p. (nW)	e.i.r.p. (dB(pW))	e.i.r.p. (dBW)	e.r.p. (dBm)	E field free space (dB(μ V/m)) at 10 m	E_{max} OATS (dB(μ V/m)) at 10 m	pfd free space (dB(W/m ²)) at 10 m	pfd maximum OATS (dB(W/m ²)) at 10 m
-90	0.001	0	-120	-92.15	-5.2	-1.2	-151.0	-147.0
-80	0.01	10	-110	-82.15	4.8	8.8	-141.0	-137.0
-70	0.1	20	-100	-72.15	14.8	18.8	-131.0	-127.0
-60	1	30	-90	-62.15	24.8	28.8	-121.0	-117.0
-50	10	40	-80	-52.15	34.8	38.8	-111.0	-107.0
-40	100	50	-70	-42.15	44.8	48.8	-101.0	-97.0
-30	1 000	60	-60	-32.15	54.8	58.8	-91.0	-87.0
-20	10 000	70	-50	-22.15	64.8	68.8	-81.0	-77.0
-10	100 000	80	-40	-12.15	74.8	78.8	-71.0	-67.0
0	1 000 000	90	-30	-2.15	84.8	88.8	-61.0	-57.0

Annex 2

Methods of measurement of spurious domain emissions

1 Measuring equipment

1.1 Selective measuring receiver

Either a selective receiver or a spectrum analyser may be used for the measurement of spurious power supplied to the antenna and cabinet radiation.

1.1.1 Weighting functions of measurement equipment

It is recommended that all measurement receivers be procured with both the mean and peak weighting functions.

1.1.2 Resolution bandwidths

As a general guideline, the resolution bandwidths (measured at the -3 dB points of the final IF filter) of the measuring receiver should be equal to the reference bandwidths as given in *recommends* 4.1. To improve measurement accuracy, sensitivity and efficiency, the resolution bandwidth can be different from the reference bandwidth. For instance, narrower resolution bandwidth is sometimes necessary for emissions close to the centre frequency. When the resolution bandwidth is smaller than the reference bandwidth, the result should be integrated over the reference bandwidth (the integration should be made on the basis of a power sum unless the spurious signal is known to be additive in voltage or with intermediate law, see Note 1). When the resolution bandwidth is greater than the reference bandwidth, the result for broadband spurious domain emissions should be normalized to the bandwidth ratio. For discrete (narrow-band) spuri, normalization is not applicable.

A correction factor to the resolution bandwidth should be introduced depending on the actual resolution bandwidth of the measuring receiver (e.g. -6 dB resolution bandwidth) and on the nature of the measured spurious domain emission (e.g. pulsed signal or Gaussian noise).

NOTE 1 – When spurious domain emission is measured in terms of PEP with a resolution bandwidth narrower than the reference bandwidth, the power sum might not be appropriate. If the addition rule is not known, the total spurious domain emission in the reference bandwidth should be evaluated using both power and voltage sum rules. In every case, if the total spurious domain emission using voltage sum rule is lower than the specified limit, then the limit is met. If the total spurious domain emission using power sum rule is higher than the specified limit, then the limit is not met.

1.1.3 Video bandwidth

The video bandwidth must be at least as large as the resolution bandwidth, and preferably be three to five times as large as the resolution bandwidth.

1.1.4 Measurement receiver filter shape factor

Shape factor is a selectivity parameter of a band-pass filter and is usually defined as the ratio of the desired rejection bandwidth to the desired pass bandwidth. In an ideal filter this ratio would be 1. However, practical filters have attenuation roll-off far from this ideal. For example, spectrum analysers which approximate Gaussian filters by using multi-tuned filters to respond to signals while in swept mode, typically define a -60 dB to -3 dB ratio ranging from 5:1 to 15:1.

1.2 Fundamental frequency rejection filter

The ratio of the power of the fundamental frequency to the power of the spurious domain emissions may be of the order of 70 dB or more. A ratio of this order may often result in an input at the fundamental frequency of a sufficient level to generate non-linearities in the selective receiver. Hence, a rejection filter to attenuate the fundamental frequency at the input of the measuring device is usually required (if the spurious domain emission frequency is not too close to the fundamental frequency). For frequency ranges well above the fundamental frequency (for harmonic frequencies

for example), it is also possible to use a band-pass or high-pass filter. The insertion loss of this filter for spurious domain emission frequencies must not be too high. However, the frequency response of the filter has to be very well characterized.

Typical variable frequency, lumped circuit rejection filters at the VHF/UHF range have only 3-5 dB insertion loss, and less, about 2-3 dB loss above 1 GHz.

Tuneable quarter wave bandpass cavity filters are available for frequency ranges above about 50 MHz because of their physical size and have insertion losses on the order of less than 1 dB. Cavity notch filters will have about the same loss once the frequency of interest is more than about 10% away from the notch frequency.

Receivers that have to cover many bands usually require variable filtering which tracks the tuned frequency of the system being measured. The types of variable filters that are adequate for spurious measurements are either varactor tuners or yttrium-iron-garnet (YIG) filters. These filters have more insertion loss than fixed filters, but have smaller passbands which allows measurement of signals that are closer in frequency to the transmitter frequencies.

Varactor tuners typically are recommended for frequencies between 50 MHz and 1 GHz. They provide a 3 dB bandwidth that is about 5% of the tuned frequency and have about 5-6 dB insertion loss.

YIG filters typically are recommended for frequencies between about 1-18 GHz. They provide a 3 dB bandwidth that is about 15 MHz at 2 GHz RF, and about 30 MHz wide at 18 GHz RF. The insertion loss is about 6-8 dB.

1.3 Coupling device

Measurements are made using a directional coupler capable of handling the power of the fundamental emission. The impedance of this coupler must match the transmitter impedance at the fundamental frequency.

1.4 Terminal load

To measure the power of spurious domain emissions, while using measurement Method 1, the transmitter shall be connected to a test load or terminal load. The level of spurious domain emission depends on proper impedance matching between the transmitter final stage, the transmission line and the test load.

1.5 Measuring antenna

Measurements are made with a tuned dipole antenna or a reference antenna with a known gain referenced to an isotropic antenna.

1.6 Condition of modulation

Whenever it is possible, the measurements are made in the presence of the maximum rated modulation under normal operating conditions. It may sometimes be useful to start the measurements without applying the modulation, in order to detect some particular spurious frequencies. In this case, it must be pointed out that all spurious domain emission frequencies may not be detected and switching the modulation on may produce other spurious frequency components.

2 Measurement limitations

2.1 Bandwidth limitations

The limits of $\pm 250\%$ of the necessary bandwidth establish the start of the measurement frequency band for spurious domain emissions in accordance with *recommends* 2.3 of this Recommendation. In some cases this is not possible because significant measurement errors may result due to the inclusion of non-spurious domain emissions. In order to establish a new boundary for the spurious domain measurement bandwidth (BW), a new frequency separation other than $\pm 250\%$ of the necessary bandwidth can be justified. Alternatively a smaller resolution bandwidth may be used with the $\pm 250\%$ of the necessary bandwidth.

The new boundary and resolution bandwidth (BW) are related by the following equation:

$$\text{Resolution BW} \times \{(\text{shape factor} - 1)\} \leq 2 \{(\text{boundary, i.e. between the out-of-band domain and spurious domain}) - (\text{necessary BW})/2\}$$

From the above equation, it is clear that if the resolution bandwidth cannot be changed, then a new boundary should be calculated. The opposite case is also true.

Consider a signal with a 16 kHz necessary bandwidth, and a $\pm 250\%$ boundary (i.e. 40 kHz) which cannot be changed. If the measuring resolution bandwidth filter has a shape factor of 15:1 and the required rejection of the carrier in-band power is 60 dB then the resolution bandwidth has to be approximately 4.5 kHz, from:

$$\text{Required resolution BW} \leq 2 \{(\text{boundary}) - (\text{necessary BW})/2\}/(\text{shape factor} - 1)$$

therefore:

$$\text{Required resolution BW} \leq 2 (40 - 16/2)/(15 - 1)$$

therefore:

$$\text{Required resolution BW} < 4.5 \text{ kHz}$$

On the other hand, given the same signal and measurement receiver parameters, if the resolution bandwidth is fixed at 100 kHz then a new boundary is calculated by rearranging the above formula and solving for the new boundary. In this case, if the resolution bandwidth is fixed at 100 kHz, then the new boundary is 708 kHz.

2.2 Sensitivity limitation

Under certain conditions, the sensitivity of commercially available spectrum analysers, together with transition and cable losses might lead to insufficient measurement sensitivity. This may be overcome by the use of a low noise amplifier.

In extreme cases, typically above 26 GHz and mostly due to the use of external mixers in the test set-up, it still may not be possible to achieve enough sensitivity to verify that the equipment under test (EUT) conforms to the specification requirement under modulated condition. The spurious domain emission measurement in the CW condition may be corrected, for those emissions that are subject to the modulation process, by an amount equal to the modulation loss of the EUT.

2.3 Time limitations

For any desired signal, where the output amplitude changes with time (e.g. non constant envelope modulation), ten or more averaged measurement may be used for consistency.

3 Methods of measurement

3.1 Introduction

There are two basic methods for measurement of spurious domain emissions described in this Annex. Method 2 is described in CISPR Publication No. 16. Care must be taken with Methods 1 and 2 that emissions from the test do not cause interference to systems in the environment, and care must also be taken to utilize the weighting function (see § 1.1.1 above) that matches the power specified in Categories A, B, C, D and Z.

- Method 1a is the measurement of spurious domain emission power supplied to the antenna port of the EUT. This method should be used whenever it is practical and appropriate.
- Method 1b is the measurement of spurious domain emission power supplied to the antenna port of the EUT. This method may be used when the fundamental rejection filter is not available and the dynamic range of the measurement receiver (possibly equipped with a preselector) is adequate.
- Method 2 is the measurement of the spurious e.i.r.p., using a suitable test site.

Systems using waveguides should use Method 2, since terminating waveguides in a transition device can cause many testing problems. If the antenna port is a waveguide flange, distant spurious domain emissions might be greatly attenuated by the waveguide to coaxial transition, unless specific tapered waveguide sections are placed in the measurement line so that Method 1 may be utilized. Similarly, VLF/LF band transmitters should also be measured using Method 2 since the boundary between the transmitter, feeder cable and antenna is not always clearly defined.

The measurement method for radar systems should be guided by Recommendation ITU-R M.1177. For those systems for which acceptable methods of measurement do not exist, all practical measures should be taken to meet the appropriate limits of the power of spurious domain emissions.

3.2 Method 1 – Measurement of the spurious domain emission power supplied to the antenna port

No particular test site or anechoic chamber is required and electromagnetic interference (EMI) should not affect the results of the tests. Whenever it is possible, the measurement should include the feeder cable. This method does not take into account attenuation due to antenna mismatch and radiation inefficiencies presented to any spuri, or the active generation of spuri by the antenna itself.

3.2.1 Method 1a – Measurement using a fundamental rejection filter

The block-diagram of the measurement set-up for the spurious domain emission power to the antenna port is shown in Fig. 1a.

FIGURE 1a

Method 1a: Measurement set-up for the spurious domain emission power to the antenna port using a fundamental rejection filter

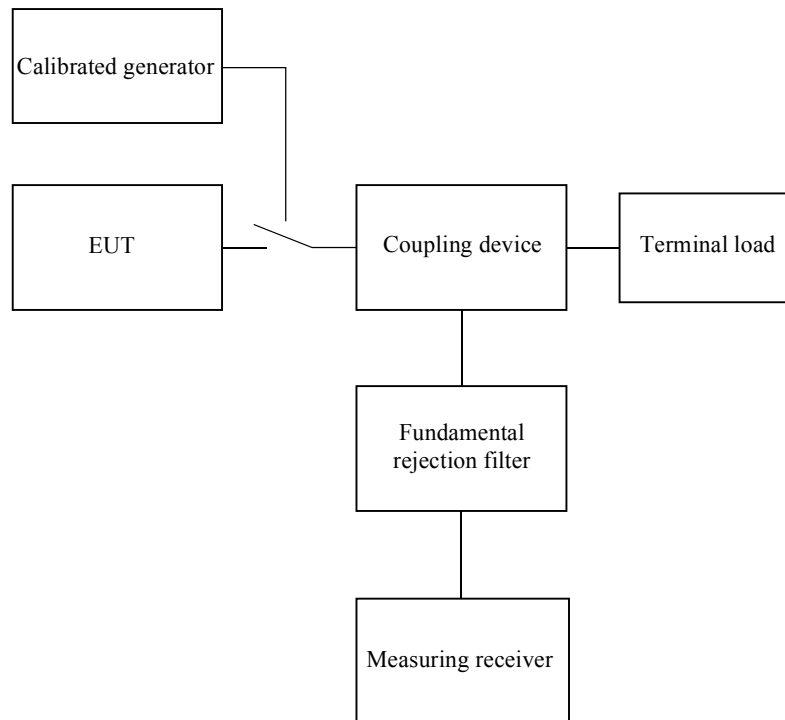

0329-01a

3.2.1.1 Direct conducted approach

In this approach, it is required to calibrate all the measuring components individually (filter(s), coupler, cables), or to calibrate these connecting devices as a whole. In either case, the calibration is performed by using a calibrated adjustable level generator at the input of the measurement receiver. At each frequency, f , the calibration factor k_f is then determined as follows:

$$k_f = I_f - O_f$$

where:

- k_f : calibration factor (dB) at the frequency, f
- I_f : input power (delivered by the calibrated generator) (dBW) or (dBm), at the frequency, f
- O_f : output power (determined by the measurement receiver) in the same unit as I_f , at the frequency, f .

This calibration factor represents the total insertion loss of all the devices connected between the generator and the measurement receiver.

If making individual device calibration measurements, calibration of the whole measurement set-up is derived by using the following formula:

$$k_{ms,f} = \sum_i k_{i,f}$$

where:

- $k_{ms,f}$: calibration factor (dB) of the measurement set-up, at the frequency, f
- $k_{i,f}$: individual calibration factor (dB) of each device in the measurement chain, at the frequency, f .

During measurement of actual spurious levels, $P_{r,f}$ (dBW) or (dBm) is the power (read on the measuring receiver) from the spurious domain emission at the frequency, f , the spurious domain emission power, $P_{s,f}$ (same unit as $P_{r,f}$) at the frequency, f , is calculated by using the following equation:

$$P_{s,f} = P_{r,f} + k_{ms,f}$$

NOTE 1 – Individual component calibration will normally lead to further measurement uncertainty because of mismatch loss.

3.2.1.2 Substitution approach

This method does not require calibration of all measuring components. Instead, the spurious output power is recorded from the measuring device. Then this power level is matched by a signal from a calibrated signal generator which is substituted for the EUT. The power supplied by the generator is then equal to the power of the spurious domain emission.

3.2.2 Method 1b – Measurement without a fundamental rejection filter

This approach provides an easy way of making a measurement in cases where no fundamental rejection filter is available. The block diagram of the measurement set-up for the spurious domain emission power to the antenna port is shown in Fig. 1b.

FIGURE 1b

Method 1b: Measurement set-up for the spurious domain emission power to the antenna port without using a fundamental rejection filter

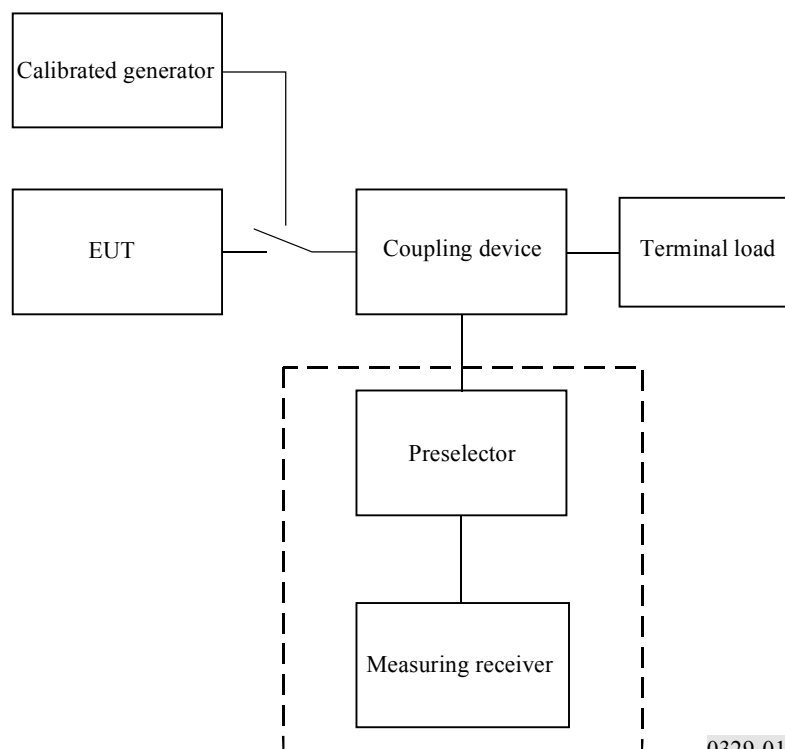

3.2.2.1 Direct conducted approach

The measurement result can be directly given by using the following procedure:

- a) Measuring the relative level for the type of equipment in Category A

Attenuation relative to total mean or peak envelope power = $B - D$

where:

B : mean or peak envelope power of the fundamental emission read on the measuring receiver

D : maximum power of the spurious domain emission read on the measuring receiver; the value of $(B - D)$ can be directly compared with the relative limits in Category A.

- b) Measuring the absolute level for types of equipment in Category A and B

The spurious domain emission power = $D + C$

where:

C : coupling factor of coupling device at the frequency of the spurious domain emission

D : maximum power of the spurious domain emission read on the measuring receiver.

The value of $(D + C)$ can be directly compared with absolute limits in Category A and B.

3.2.2.2 Substitution approach

Method 1b may also make use of the substitution approach described in § 3.2.1.2 for absolute level measurements.

3.3 Method 2 – Measurement of the spurious domain emission e.i.r.p.

The block-diagram of the measuring set-up for the spurious domain emission e.i.r.p. is shown in Fig. 2.

The measurements must be made in the far field, which is often difficult for very low frequencies or for certain combinations of frequency and antenna size (e.g. transmissions at 14 GHz using a 1.2 m dish requires about 140 m to reach the far field). The measurements of the e.i.r.p. of the spurious domain emissions in any direction, in several polarizations and for any frequency could be very time consuming, although techniques to check compliance may reduce this workload. The use of this method to measure radars should be guided by Recommendation ITU-R M.1177.

FIGURE 2
Measuring set-up for the spurious domain emission e.i.r.p.

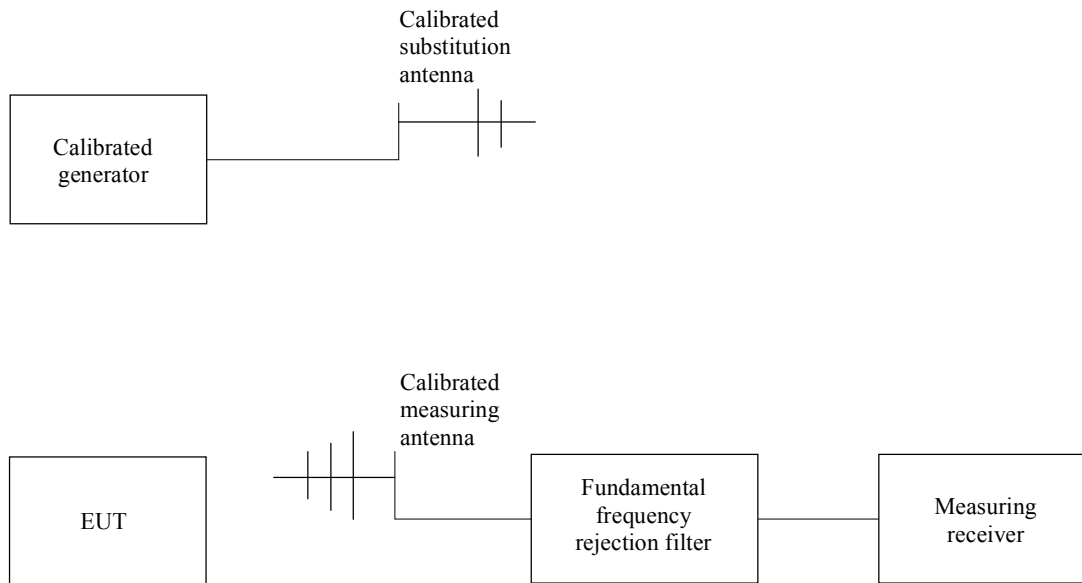

0329-02

3.3.1 Measurement sites for radiated measurements

In the frequency range 30 to 1 000 MHz, test sites shall be validated by making site attenuation measurements for both horizontal and vertical polarization fields. A measurement site shall be considered acceptable if the horizontal and vertical site attenuation measurements are within ± 4 dB of the theoretical site attenuation.

The test site shall characteristically be flat, free of overhead wires and nearby reflecting structures, sufficiently large to permit antenna placement at the specified distance and provide adequate separation between antenna, EUT and reflecting structures. Reflecting structures are defined as those whose construction material is primarily conductive. The test site shall be provided with a horizontal metal ground-plane. The test site shall satisfy the site attenuation requirements of IEC/CISPR Publication No. 16-1 for OATS.

Tests may also be conducted in a semi-anechoic room (SAR). In that case, the walls and the ceiling of a shielded room are covered with absorber materials that ensure low wave reflection. Validation measurements of such anechoic chambers are very important to ensure that the site attenuation measurements can be performed within the ± 4 dB criteria (see also IEC/CISPR Publications Nos. 16-1 and 22).

For both OATS and SAR a conducting ground-plane shall extend at least 1 m beyond the periphery of the EUT and the largest measuring antenna, and cover the entire area between the EUT and the antenna. It should be of metal with no holes or gaps, having dimensions larger than one tenth of the wavelength at the highest frequency of measurement. A larger size conducting ground-plane may be required if the site attenuation requirements of the test site are not satisfied. These requirements are also applicable in the case of semi-anechoic chambers.

Additional equipment is becoming available as the site for spurious domain emission measurements. These are various chambers, such as fully anechoic rooms (FAR), stirred mode chambers (SMC), and transverse electromagnetic (TEM) or Gigahertz TEM (GTEM) systems. The SMC is described in IEC/CISPR Publication No. 16-1. These relatively new measurement systems are not universally accepted as yet by all standardization bodies. Drafts have been published (in Autumn 2000) for IEC 61000-4-20 (TEM) and IEC 61000-4-21 (SMC). The techniques used with these systems should be re-examined when this Recommendation is updated in the future, with a view towards incorporating details of their use.

3.3.2 Direct approach

In this approach, it is required to calibrate all the measuring components individually (filter(s), cables), or to calibrate the whole measuring set. See § 3.2.1 on direct approach for the determination of the calibration factor of the measuring set at the frequency, f .

The spurious domain emission e.i.r.p., $P_{s,f}$, at the frequency f , is given for free space conditions by the following equation:

$$P_{s,f} = P_{r,f} + k_{ms,f} - G_f + 20 \log f + 20 \log d - 27.6$$

where:

- $P_{r,f}$: power of the spurious domain emission read on the measuring receiver at the frequency, f (dBW or dBm, same units as $P_{s,f}$)
- $k_{ms,f}$: calibration factor of the measuring set-up at the frequency, f (dB), (generally positive)
- G_f : gain of the calibrated measuring antenna at the frequency, f (dBi)
- f : frequency of the spurious domain emission (MHz)
- d : distance (m) between the transmitting antenna and the calibrated measuring antenna.

In addition the reflection gain has to be taken into consideration when an OATS is used.

3.3.3 Substitution approach

In this approach, a calibrated substitution antenna and a calibrated generator are used, the test source being adjusted for the same received spurious signal.

3.4 Special cabinet radiation measurement

To provide a means of measuring cabinet radiation, Method 2 can be used to measure transmitter cabinet spurious radiation. This method requires replacing the EUT antenna with a calibrated terminal load, and proceeding with the approaches listed above for Method 2, to obtain case e.i.r.p. The terminating dummy load should be placed in a small, separate shielded enclosure so that re-radiation from the load does not interfere with the measuring of radiation from the cabinet under test. Additionally, connecting cables may radiate and adversely affect the measurements, so care must be taken to prevent this by using double shielded cables or using the shielded enclosure for the cables also.

Annex 3

Threshold levels of interference for the radio astronomy service and space services using passive sensors

1 Introduction

Threshold levels of interference for the radio astronomy service, Earth exploration-satellite and meteorological-satellite services using passive sensors can be found in Recommendations ITU-R RA.769 and ITU-R SA.1029. This Annex summarizes the levels provided in these Recommendations.

2 Radio astronomy service (Recommendation ITU-R RA.769)

Table 8 gives the threshold levels of pfd for interference detrimental to the radio astronomy service as it appears in Recommendation ITU-R RA.769 for those frequency bands listed in this Recommendation; this includes all bands allocated to the radio astronomy service on a primary basis, except the eight bands allocated via RR No. 5.555. These are calculated for observations with a single antenna and reception in sidelobes of gain 0 dBi and an integration time of 2000 s. The values of pfd given in Table 8 apply generally, except for GSO satellites for which the pfd is 15 dB more stringent than shown (see Recommendation ITU-R RA.769).

Annex 1 to Recommendation ITU-R RA.769 describes the methodology for calculating the sensitivity of various radio astronomy systems currently in use. It also provides, for assumed values of system parameters, tabulated levels of aggregate interference which are detrimental to both continuum and spectral-line measurements for various bands allocated to the radio astronomy service.

The assumed parameters used to derive these levels are representative of many types of radio astronomy systems and measurements and are an agreed acceptable standard within the radio astronomy service. However, there may be circumstances in coordination with a specific radio astronomy system, operating at a particular time and location in a particular band, where other values of these parameters may be used with the same methodology to derive a more appropriate level of detrimental interference. In addition, for consideration of interference from specific types of systems (e.g. GSO satellites or multiple-satellite systems) a systematic adjustment of the levels in Recommendation ITU-R RA.769 may be warranted. Accordingly, when the levels contained in Table 8 are applied or referred to, account should be taken of the assumptions used to derive them.

TABLE 8

**Threshold levels of pfd of interference detrimental
to the radio astronomy service***

Radio astronomy band ⁽¹⁾ (MHz)	Continuum observations		Spectral lines observations	
	pfd (dB(W/m ²))	Assumed bandwidth (MHz)	pfd (dB(W/m ²))	Assumed spectral line channel bandwidth (kHz)
13.36-13.41	-201	0.05	(2)	(2)
25.55-25.67	-199	0.120	(2)	(2)
73.0-74.6	-196	1.6	(2)	(2)
150.05-153.0	-194	2.95	(2)	(2)
322.0-328.6	-189	6.6	-204	10
406.1-410.0	-189	3.9	(2)	(2)
608-614	-185	6	(2)	(2)
1 400-1 427	-180	27	-196	20
1 610.6-1 613.8	(3)	(3)	-194	20
1 660-1 670	-181	10	-194	20
2 690-2 700	-177	10	(2)	(2)
4 990-5 000	-171	10	(2)	(2)
(GHz)				
10.6-10.7	-160	100	(2)	(2)
15.35-15.4	-156	50	(2)	(2)
22.21-22.5	(3)	(3)	-162	250
23.6-24.0	-147	400	-161	250
31.3-31.8	-141	500	(2)	(2)
42.5-43.5	-137	1 000	-153	500
86-92	-125	6 000	-144	1 000
105-116	-121	11 000	-141	1 000
164-168	-120	4 000	(2)	(2)
182-185	(3)	(3)	-136	1 500
217-231	-114	14 000	-133	2 500
265-275	-113	10 000	-131	2 500

* The levels are calculated under specific assumptions given in Recommendation ITU-R RA.769, in particular with an integration time of 2 000 s.

(1) These are the frequency bands listed in Recommendation ITU-R RA.769; eight further bands are allocated to the radio astronomy service on a primary basis via RR No. 5.555.

(2) Not listed in Table 2 of Recommendation ITU-R RA.769.

(3) Not listed in Table 1 of Recommendation ITU-R RA.769.

3 Earth exploration-satellite and meteorological-satellite passive sensing (Recommendation ITU-R SA.1029)

The permissible interference levels given in Table 9 are based on Recommendation ITU-R SA.1029. They refer to power levels at the receiver input and do not include characteristics of the receiving antenna. The gain of the receiving antenna may be inferred from the values of resolution (km) given in Table 2 of Recommendation ITU-R SA.515 and the knowledge that a typical orbital altitude for spaceborne remote sensors can be taken as 500 km. Note that for spaceborne remote sensing, the sensor antenna is normally directed at the Earth's surface. Note that the levels in Table 9 are described as permissible in the context that they meet the interference criteria of passive sensors. However, use of permissible may not necessarily conform with a strict regulatory definition.

TABLE 9

Permissible interference levels at the receiver input for passive sensing

Frequency (GHz)	Interference level (dBW)	Interference reference bandwidth (MHz)
1.4-1.427	-171	27
2.69-2.7	-174	10
4.2-4.4	-161	100
6.5-6.7	-164	100
10.6-10.7	-163	20
15.2-15.4	-166	50
18.6-18.8	-155 ⁽¹⁾	100
21.2-21.4	-163	100
22.21-22.5	-160	100
23.6-24	-163	100
31.3-31.8	-163	100
36-37	-156	100
50.2-50.4	-161/-166 ⁽²⁾	100
52.6-59	-161/-166 ⁽²⁾	100
60.3-61.3	-161/-166 ⁽²⁾	100
86-92	-153	200
100-102	-160	200
105-126	-160	200
150-151	-160	200
155.5-158.5	-160	200
164-168	-160	200
175-192	-160	200

TABLE 9 (*end*)

Frequency (GHz)	Interference level (dBW)	Interference reference bandwidth (MHz)
200-202	-160	200
217-231	-160	200
235-238	-160	200
250-252	-160	200
275-277	-160	200
300-302	-160	200
324-326	-160	200
345-347	-160	200
363-365	-160	200
379-381	-160	200

⁽¹⁾ This value is under study.

⁽²⁾ Second number for pushbroom sensors.

Annex 4

List of ITU-R Recommendations relating to spurious emissions for some specific services

Recommendation ITU-R SM.239	Spurious emissions from sound and television broadcast receivers
Recommendation ITU-R S.726	Maximum permissible level of spurious emissions from very small aperture terminals (VSATs)
Recommendation ITU-R RA.611	Protection of the radioastronomy service from spurious emissions
Recommendation ITU-R M.1177	Techniques for measurement of unwanted emissions of radar systems
Recommendation ITU-R F.1191	Bandwidths and unwanted emissions of digital fixed service systems
Recommendation ITU-R BT.803	The avoidance of interference generated by digital television studio equipment
Recommendation ITU-R M.478	Technical characteristics of equipment and principles governing the allocation of frequency channels between 25 and 3 000 MHz for the FM land mobile service
Recommendation ITU-R M.1343	Essential technical requirements of mobile earth stations for global non-geostationary mobile-satellite service systems in the bands 1-3 GHz

Annex 5

Examples of applying $43 + 10 \log P$ to calculate attenuation requirements

All unwanted emissions are to be at least x dB down from the total mean power P , i.e. $-x$ dBc. The power P (W) is to be measured in a bandwidth wide enough to include the total mean power. The spurious domain emissions are to be measured in the reference bandwidths given in this Recommendation. The measurement of the spurious domain emission power is independent of the value of necessary bandwidth. Note that the attenuation of $43 + 10 \log P$ always results in an absolute spurious domain emission power level of -43 dBW or -13 dBm. Because this absolute emission power limit can become too stringent for high power transmitters, alternate relative powers are also provided in Table 2.

Example 1:

A land mobile transmitter, with any value of necessary bandwidth, must meet a spurious domain emission attenuation of $43 + 10 \log P$, or 70 dBc, whichever is less stringent. To measure spurious domain emissions in the frequency range between 30 and 1 000 MHz, *recommends* 4.1 indicates use of a reference bandwidth of 100 kHz. For other frequency ranges, the measurement must use the appropriate reference bandwidths given in *recommends* 4.1.

With a measured total mean power of 10 W:

Attenuation relative to total mean power = $43 + 10 \log 10 = 53$ dB

The 53 dBc is less stringent than 70 dBc, so the 53 dBc value is used.

Therefore:

Spurious domain emissions must not exceed 53 dBc in a 100 kHz reference bandwidth, or converting to an absolute level

Spurious domain emissions must not exceed $10 \text{ dBW} - 53 \text{ dBc} = -43 \text{ dBW}$ in a 100 kHz reference bandwidth.

With a measured total mean power of 1 000 W:

Attenuation relative to total mean power = $43 + 10 \log 1\,000 = 73$ dB

The 73 dBc is more stringent than 70 dBc limit, so the 70 dBc value is used.

Therefore:

Spurious domain emissions must not exceed 70 dBc in a 100 kHz reference bandwidth, or converting to an absolute level

Spurious domain emissions must not exceed $30 \text{ dBW} - 70 \text{ dBc} = -40 \text{ dBW}$ in a 100 kHz reference bandwidth.

Example 2:

A space services transmitter, with any value of necessary bandwidth, must meet a spurious domain emission attenuation of $43 + 10 \log P$, or 60 dBc, whichever is less stringent. To measure spurious domain emissions at any frequency, footnote⁽³⁾ of Table 2 indicates using a reference bandwidth of 4 kHz.

With a measured total mean power of 20 W:

Attenuation relative to total mean power = $43 + 10 \log 20 = 56$ dB

The 56 dBc is less stringent than the 60 dBc limit, so the 56 dBc value is used.

Therefore:

Spurious domain emissions must not exceed 56 dBc in a 4 kHz reference bandwidth or converting to an absolute level

Spurious domain emissions must not exceed $13 \text{ dBW} - 56 \text{ dBc} = -43 \text{ dBW}$ in a 4 kHz reference bandwidth.

TABLE 10

Absolute levels of spurious domain emissions – Category A

Service category in accordance with RR Article 1 or equipment type ^{(1), (2)}	Maximum permitted spurious domain emission power in the relevant reference bandwidth (see recommends 4.1) (dBm) with P , PEP or X (W)	
All services except those services quoted below	-13 dBm $10 \log P - 40$	if $P \leq 500 \text{ W}$ if $P > 500 \text{ W}$
Space services (mobile earth stations) ^{(3), (4)}	-13 dBm $10 \log P - 30$	if $P \leq 50 \text{ W}$ if $P > 50 \text{ W}$
Space services (fixed earth stations) ^{(3), (4)}	-13 dBm $10 \log P - 30$	if $P \leq 50 \text{ W}$ if $P > 50 \text{ W}$
Space services space stations ^{(3), (5), (6)}	-13 dBm $10 \log P - 30$	if $P \leq 50 \text{ W}$ if $P \geq 50 \text{ W}$
Radiodetermination ⁽⁷⁾	-13 dBm $10 \log PEP - 30$	if $PEP \leq 50 \text{ W}$ if $PEP > 50 \text{ W}$
Broadcast TV ⁽⁸⁾ VHF transmitters	-16 dBm $10 \log P - 30$ 0 dBm	if $P \leq 25 \text{ W}$ if $25 \text{ W} < P \leq 1\,000 \text{ W}$ if $P > 1\,000 \text{ W}$
Broadcast TV ⁽⁸⁾ UHF transmitters	-16 dBm $10 \log P - 30$ 10.8 dBm	if $P \leq 25 \text{ W}$ if $25 \text{ W} < P \leq 12\,000 \text{ W}$ if $P > 12\,000 \text{ W}$

TABLE 10 (*end*)

Service category in accordance with RR Article 1 or equipment type ^{(1), (2)}	Maximum permitted spurious domain emission power in the relevant reference bandwidth (see <i>recommends</i> 4.1) (dBm) with P , PEP or X (W)	
Broadcast FM	-16 dBm $10 \log P - 40$ 0 dBm	if $P \leq 250$ W if $250 \text{ W} < P \leq 10\,000$ W if $P > 10\,000$ W
Broadcast MF/HF	$10 \log P - 20$ 17 dBm	if $P \leq 5\,000$ W if $P > 5\,000$ W
SSB from mobile stations ⁽⁹⁾	$10 \log PEP - 13$	
Amateur services operating below 30 MHz (including with SSB) ⁽⁹⁾	-13 dBm $10 \log PEP - 20$	if $PEP \leq 5$ W if $PEP > 5$ W
Services operating below 30 MHz, except space, radiodetermination, broadcast, those using SSB from mobile stations, and amateur ⁽⁹⁾	-13 dBm $10 \log X - 30$ where:	if $X \leq 50$ W if $X > 50$ W $X = PEP$ for SSB modulation $X = P$ for other modulation
Low power device radio equipment ⁽¹⁰⁾	-26 dBm $10 \log P - 10$	if $P \leq 0.025$ W if $0.025 \text{ W} < P < 0.100$ W
EPIRB, ELT, PLB, SART, ship emergency, lifeboat, and survival craft transmitters, land, aeronautical or maritime transmitters when used in emergency	No limit	

P : mean power (W) at the antenna transmission line, in accordance with RR No. 1.158. When burst transmission is used, the mean power P and the mean power of any spurious domain emissions are measured using power averaging over the burst duration.

PEP : peak envelope power (W) at the antenna transmission line, in accordance with RR No. 1.157.

When the term P is used, both the power supplied to the antenna transmission line and spurious domain emissions should be evaluated in terms of mean power and mean power in the reference bandwidth respectively. When the term PEP is used, both the power supplied to the antenna transmission line and spurious domain emissions should be evaluated in terms of peak envelope power and peak envelope power in the reference bandwidth respectively. However, when measurement of spurious domain emission in terms of PEP is difficult due to the nature of spurious domain emission (e.g. Gaussian noise), it is allowed to evaluate both power supplied to the antenna transmission line and spurious domain emission power in terms of mean power (see Annex 2).

Notes to Table 10 (continued):

dBc: decibels relative to the unmodulated carrier power of the emission. In the cases which do not have a carrier, for example in some digital modulation schemes where the carrier is not accessible for measurement, the reference level equivalent to dBc is decibels relative to the mean power, P.

- (1) In some cases of digital modulation and narrow-band high power transmitters for all categories of services, there may be difficulties in meeting limits close to $\pm 250\%$ of the necessary bandwidth.
- (2) Use the e.i.r.p. method shown in Annex 2, § 3.3, when it is not practical to access the transition between the transmitter and the antenna transmission line.
- (3) Spurious domain emission limits for all space services are stated in a 4 kHz reference bandwidth.
- (4) Earth stations in the amateur-satellite service operating below 30 MHz are in the service category "Amateur services operating below 30 MHz (including with SSB)".
- (5) For the case of a single satellite operating with more than one transponder in the same service area, and when considering the limits for spurious domain emissions as indicated in Table 10, spurious domain emissions from one transponder may fall on a frequency at which a second, companion transponder is transmitting. In these situations, the level of spurious domain emissions from the first transponder is well exceeded by the fundamental or out-of-band domain emissions of the second transponder. Therefore, the limits should not apply to those spurious domain emissions of a satellite that fall within either the necessary bandwidth or the out-of-band domain of another transponder on the same satellite, in the same service area (see RR Appendix 3).
- (6) Space stations in the space research service intended for operation in deep space as defined by RR No. 1.177 are exempt from spurious domain emission limits.
- (7) For radiodetermination systems (radar as defined by RR No. 1.100), spurious domain emission attenuation (dB) shall be determined for radiated emission levels, and not at the antenna transmission line. The measurement method for determining the radiated spurious domain emission levels from radar systems should be guided by Recommendation ITU-R M.1177.
- (8) For analogue television transmissions, the mean power level is defined with a specified video signal modulation. This video signal has to be chosen in such a way that the maximum mean power level (e.g., at the video signal blanking level for negatively modulated television signals) is provided to the antenna transmission line.
- (9) All classes of emission using SSB are included in the category SSB.
- (10) Low power radio device having a maximum output power of less than 100 mW and intended for short range communication or control purposes (Such equipment is in general exempt from individual licensing.).

Annex 6

**Reference bandwidth for Category B limits
Case of the fixed service**

Analogue and digitally modulated radio-relays although generally providing a good spectrum efficiency, are unable to comply with the Category B limits for close-in frequencies due to the wideband noise generated by such systems. It is therefore necessary to provide generic steps of reference bandwidth in order to produce suitable transition area for the spectral density.

The generic reference mask is shown in Fig. 3, with breakpoints function of the channel separation (CS) or the necessary bandwidth (NB) referred to in Table 11.

FIGURE 3
Generic Category B fixed service mask for unwanted emissions in the spurious domain
(refer to Table 11)

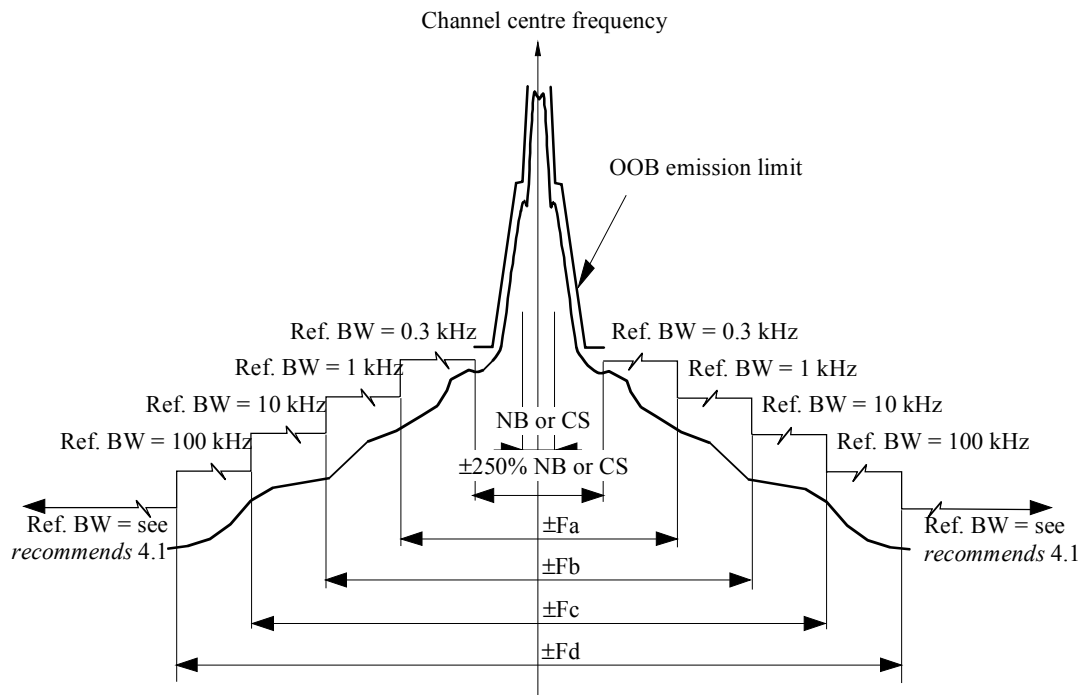

Note 1 – $\pm F_d$ frequency steps are not applicable if lower than 1 GHz.
 $\pm F_c$ frequency steps are not applicable if lower than 30 MHz.
 $\pm F_b$ frequency steps are not applicable if lower than 150 kHz.

TABLE 11

**Generic Category B fixed service mask for unwanted emissions
in the spurious domain**

(refer to Fig. 3)

Fundamental emission frequency	CS (MHz)	Typical symbol frequency (~Mbit/s)	Ref. BW 0.3 kHz	Ref. BW 1 kHz	Ref. BW 10 kHz	Ref. BW 100 kHz
			Fa (MHz)	Fb (MHz)	Fc (MHz)	Fd (MHz)
Below 21.2 GHz (terminal stations)	$0.01 \leq CS < 1$	$F_s \cong 0.006 - 0.8$	–	–	14	70
	$1 \leq CS < 10$	$F_s \cong 0.6 - 8$	–	–	28	70
	$CS \geq 10$	$F_s \sim > 6$	–	–	49 ⁽¹⁾	70 ⁽¹⁾
Below 21.2 GHz (other stations)	$0.01 \leq CS < 1$	$F_s \cong 0.006 - 0.8$	3.5	7	14	70
	$1 \leq CS < 10$	$F_s \cong 0.6 - 8$	–	14 ⁽¹⁾	28	70
	$CS \geq 10$	$F_s \sim > 6$	–	–	49 ⁽¹⁾	70 ⁽¹⁾
Above 21.2 GHz (all stations)	$1 \leq CS < 10$	$F_s \cong 0.6 - 8$	–	–	–	70
	$CS \geq 10$	$F_s > \sim 6$	–	–	–	–

⁽¹⁾ Not applicable for CS which 250% exceed these values.

Annex 7

Reference bandwidth for Category B limits Case of the land mobile service

Narrow-band analogue modulated systems of the land mobile service, with output power higher than 1 W and operated above 30 MHz, and digitally modulated systems of the land mobile service, although generally providing a good spectrum efficiency, are unable to comply with the Category B limits for close-in frequencies due to the wideband noise generated by such systems. It is therefore necessary to provide generic steps of reference bandwidth in order to produce suitable transition area for the spectral density.

The generic reference bandwidth mask is shown in Fig. 4, with breakpoints function of the CS or the NB referred to in Table 12, for frequencies below 1 GHz and in Fig. 5, with breakpoints function of the CS or the NB referred to in Table 13, for frequencies above 1 GHz.

These masks shall apply to both mobile terminals and base stations.

FIGURE 4
Generic Category B land mobile service mask below 1 GHz for unwanted emissions in the spurious domain
 (refer to Table 12)

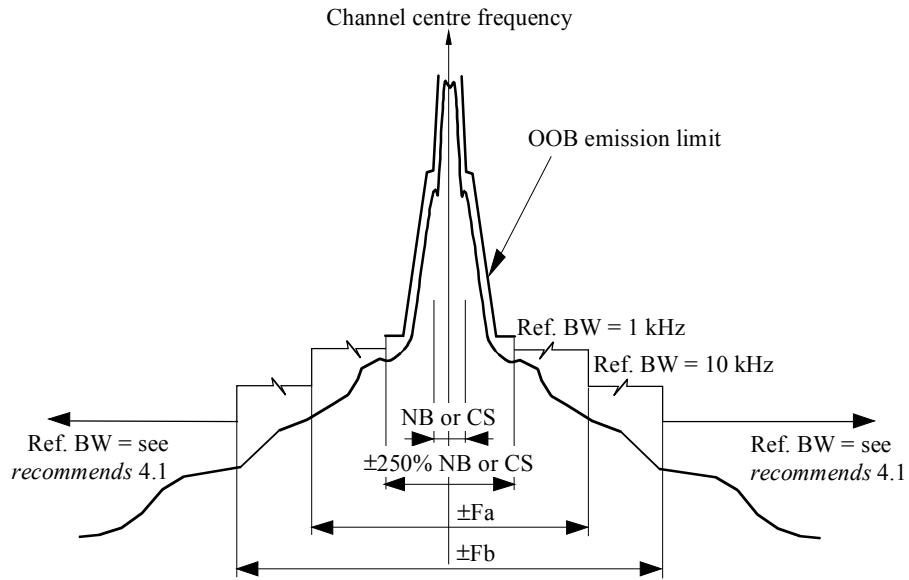

0329-04

TABLE 12
Generic Category B land mobile service mask below 1 GHz
for unwanted emissions in the spurious domain

(refer to Fig. 4)

Fa	100 kHz or 4 times NB, whichever is the greater
Fb	500 kHz or 10 times NB, whichever is the greater

FIGURE 5
Generic Category B land mobile service mask above 1 GHz for unwanted emissions in the spurious domain
 (refer to Table 13)

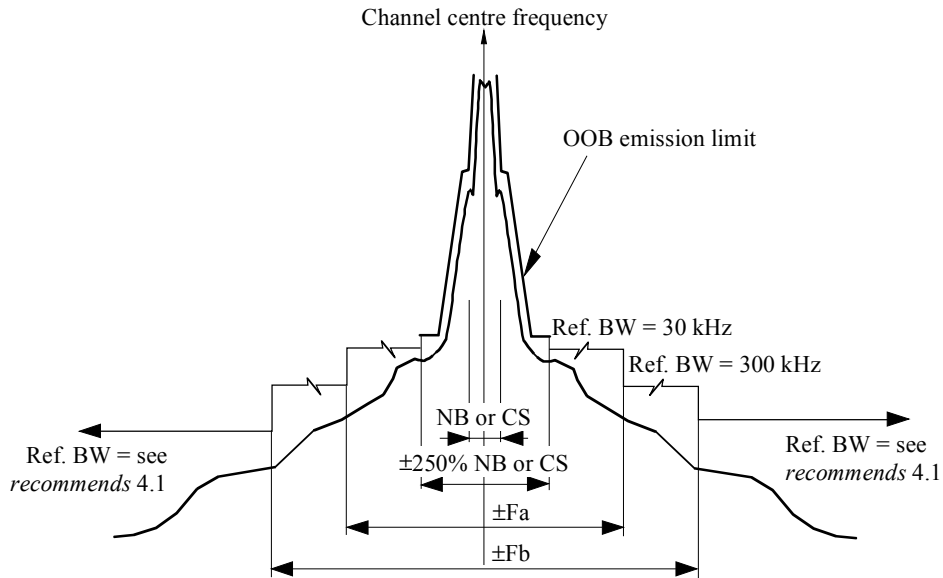

0329-05

TABLE 13
**Generic Category B land mobile service mask above 1 GHz
 for unwanted emissions in the spurious domain.**

(refer to Fig. 5)

Fa	500 kHz or 10 times NB, whichever is the greater
Fb	1 MHz or 12 times NB, whichever is the greater

