

Technical Specifications for Interoperability

International Specifications and National Standards

Keith Mainwaring

Ukrainian National Information Systems (UNIS)

Trinidad & Tobago, 2 – 4 December 2014



Why standardisation?

- **Interoperability**
 - Compatibility between equipment from different sources
 - Manufacturers
 - Users (Network Operators)
 - Interface characteristics & system behaviour
 - Between systems
 - Between components within a system

International Organisation for Standardisation (ISO)

- Organisation of National Standardisation Institutes
 - ◆ Member Bodies (119)
 - e.g. Trinidad & Tobago Bureau of Standards (TTBS)
 - Tunisia - Institut National de la Normalisation et de la Propriété Industrielle (INNORPI)
 - ◆ Correspondent Members (42)
 - e.g. Zambia Bureau of Standards (ZABS)
 - ◆ Subscriber Members (4)
 - e.g. Lao People's Democratic Republic Department of Intellectual Property, Standardization and Metrology (DISM)

International Electrotechnical Committee (IEC)

- Organisation of National Standardisation Institutes
 - ◆ Full Member (60)
 - ◆ Associate Member (23)
 - e.g. Tunisia
- Note: Trinidad & Tobago, Zambia & Laos are not members)

Regional Standardisation Organisations (Africa & Americas)

- African Organisation for Standardisation (ARSO)
- South African Development Community Cooperation in Standardisation (SADCSTAN)
- Pan American Standards Commission (COPANT)
- AMN - Asociación MERCOSUR de Normalización (MERCOSUR Association for Standardization)
- CARICOM Regional Organisation for Standards and Quality (CROSQ)

International Telecommunications Union (ITU)

- Member States (193)
- ITU-T, ITU-R, ITU-D
 - Sector Members
 - Associate Members
 - Academia

The Traditional Standardisation Process

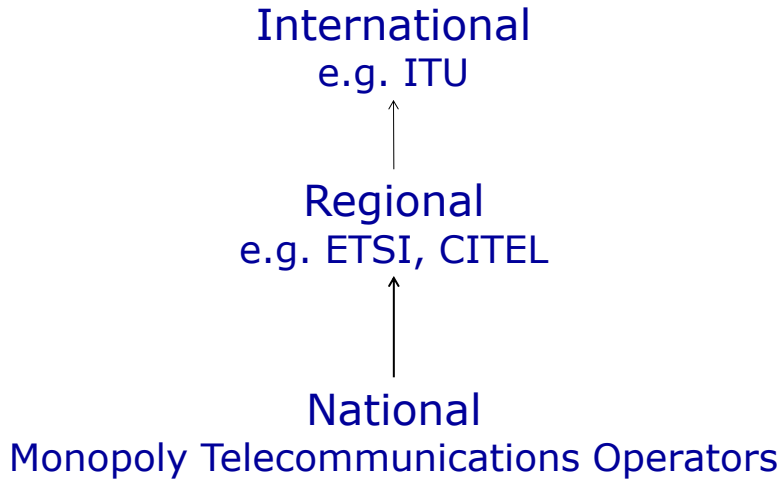

Telecommunications Standardisation in Practice Today



Advancing open standards for the information society

An array of "international" forums

Due to:

- Competition in telecommunications markets
- Technological change (Internet & Mobile)

But still

- Some international / regional organisations
- Some mandatory standards set by international / regional organisations (e.g. the European Union)
- National standards (in particular for equipment approval for access to the market)

ITU Recommendations suitable for conformity assessment & interoperability testing



ITU-T Recommendations

- **Methodology**
- Recommendations X.290 Series - OSI conformance testing methodology and framework for protocol Recommendations for ITU-T applications
- X.290 General concepts
- X.291 Abstract test suite specification
- X.292 The Tree and Tabular Combined Notation (TTCN)
- X.293 Test Realization
- X.294 Requirements on test laboratories and clients for the conformance assessment process
- X.295 Protocol profile test specification
- X.296 Implementation conformance statements
- Z.100 – Z.109 Specification and Description Language (SDL)
- Z.110 – Z.119 Application of formal description techniques
- Z.120 – Z.129 Message Sequence Chart (MSC)
- Z.150 – Z. 159 User Requirements Notation (URN)
- Z.160 – Z.179 Testing and Control Notation (TTCN-3)



ISDN Test Specifications

- Q.765bis – SS7 Application transport mechanism: Test suite structure and test purposes (TSS & TP)
- Q.780 Signalling System No. 7 test specification – General description
- Q.781 MTP level 2 test specification
- Q.782 MTP level 3 test specification
- Q.783 TUP test specification
- Q.784 ISUP basic call test specification
- Q.784.1 ISUP basic call test specification: Validation and compatibility for ISUP'92 and Q.767 protocols
- Q.784.2 ISUP basic call test specification: Abstract test suite for ISUP'92 basic call control procedures
- Q.784.3 ISUP basic call test specification: ISUP '97 basic call control procedures – Test suite structure and test purposes (TSS & TP)
- Q.785 ISUP protocol test specification for supplementary services
- Q.785.2 ISUP'97 supplementary services – Test suite structure and test purposes (TSS & TP)
- Q.786 SCCP test specification
- Q.787 Transaction capabilities (TC) test specification
- Q.788 User-network-interface to user-network-interface compatibility test specifications for ISDN, non-ISDN and undetermined accesses interworking over international ISUP
- Q.921bis Abstract test suite for LAPD conformance testing
- Q.933bis Abstract test suite – Signalling specification for frame mode basic call control conformance testing for permanent virtual connections (PVCs)

ISDN

- Q.703 (1996-07) MTP signaling link
- Q.704 (1996-07) MTP Signalling network functions and messages
- Q.706 (1993-03) Message transfer part signalling performance
- Q.707 (1988-11) MTP Testing and maintenance
- Q.711 (2001-03) Functional description of the signalling connection control part
- Q.712 (1996-07) Definition and function of Signalling connection control part messages
- Q.713 (2001-03) Signalling connection control part formats and codes
- Q.714 (2001-05) Signalling connection control part procedures
- Q.721 (1988-11) Functional description of the Signalling System No. 7 Telephone User Part (TUP)
- Q.722 (1988-11) General function of telephone messages and signals
- Q.723 (1988-11) Telephone user part formats and codes
- Q.724 (1988-11) Telephone user part signalling procedures
- Q.730 (1988) ISUP supplementary services (1988 version covered by test specification – latest version of Q.730 1999-12)
- Q.761 (1999-12) SS7 ISDN User Part functional description
- Q.762 (1999-12) SS7 ISDN User Part general functions of messages and signals
- Q.763 (1999-12) SS7 ISDN User Part formats and codes
- Q.764 (1999-12) SS7 ISDN User Part signalling procedures
- Q.765 (2000-06) SS7 application transport mechanism
- Q.767 (1991-02) Application of the ISDN User Part of CCITT signalling system No. 7 for international ISDN interconnections
- Q.771 (1993) Functional description of transaction capabilities (93 version covered by test specification – latest version of Q.771 – Q.774 1997-06)
- Q.772 (1993) Transaction capabilities information element definitions
- Q.773 (1993) Transaction capabilities formats and encoding
- Q.774 (1993) Transaction capabilities procedures
- Q.921 (1997-09) ISDN user-network interface – Data link layer specification

SIP-ISDN interworking

- Q.1912.5 (2004-03) Interworking between Session Initiation Protocol (SIP) and Bearer Independent Call Control protocol or ISDN User Part
 - ▶ *[Conformance test suites in Q.3900 Series Recommendations]*

NGN Testing (1)

- Q.3900: Methods of testing and model network architecture for NGN technical means testing as applied to public telecommunication network
- Q.3901: Testing topology for networks and services based on NGN technical means
- Q.3902: Operational parameters to be monitored when implementing NGN technical means in public telecommunication networks
- Q.3903: Formalized presentation of testing results
- Q.3904: Testing principles for IMS model networks, and identification of relevant conformance, interoperability and functionality tests
- Q.3906.1: Test scenarios and catalogue for testing fixed-broadband access networks using a model network – Part I
- Q.3909: The framework and overview of NGN conformance and interoperability testing
- Q.3910: Parameters for monitoring NGN protocols
- Q.3911: Parameters for monitoring voice services in NGN
- Q.3912: Set of parameters for monitoring next generation network streaming services
- Q.3913: Set of parameters for monitoring internet of things devices
- Q.3925: Traffic flow types for testing quality of service parameters on model networks

NGN Testing (2)

- Q.3930: Performance testing of distributed systems - Concepts and terminology
- Q.3931.1: Performance benchmark for the PSTN/ISDN emulation subsystem of an IP multimedia system – Part 1: Core concepts
- Q.3931.2: Performance benchmark for the PSTN/ISDN emulation subsystem of an IP multimedia system - Part 2: Subsystem configurations and benchmarks
- Q.3931.3: Performance benchmark for the PSTN/ISDN emulation subsystem of an IP multimedia system - Part 3: Traffic Sets and Traffic Profiles
- Q.3940: NGN/IMS interconnection tests between network operators at the IMS 'Ic' interface and NGN NNI / SIP-I
- Q.3941.1: Network integration testing between SIP and ISDN/PSTN network signalling protocols – Part 1: Test suite structure and test purposes for SIP-ISDN
- Q.3941.2: Network integration testing between SIP and ISDN/PSTN network signalling protocols – Part 2: Abstract test suite and partial protocol implementation extra information for testing proforma specification for SIP-ISDN
- Q. 3941.3: Network integration testing between SIP and ISDN/PSTN network signalling protocols – Part 3: Test suite structure and test purposes for SIP-SIP
- Q. 3941.4: Network integration testing between SIP and ISDN/PSTN network signalling protocols – Part 4: Abstract test suite and partial protocol implementation extra information for testing proforma specification for SIP-SIP

NGN Testing (3)

- Q.3942.1: Conformance test specification for the terminating identification restriction using IP multimedia core network subsystem – Part 1: Protocol implementation conformance statement
- Q.3943.1: Conformance tests specification for the originating identification presentation and originating identification restriction using the IP multimedia core network subsystem – Part 1: Protocol
- Q.3943.2: Conformance tests specification for the originating identification presentation and originating identification restriction using the IP multimedia core network subsystem – Part 2: Network side – Test suite structure and test purposes
- Q.3943.3: Conformance tests specification for the originating identification presentation and originating identification restriction using the IP multimedia core network subsystem – Part 3: User side – Test suite structure and test purposes
- Q.3945: Test specifications for next generation network services on model networks - Test set 1
- Q.3946.1: Conformance Tests Specification for the session initiation protocol - Part 1: Protocol Implementation Conformance Statement (PICS) proforma
- Q.3946.2: Conformance test specification for the session initiation protocol – Part 2: Test suite structure and test purposes
- Q.3946.3: Conformance Tests Specification for the session initiation protocol - Part 3: Abstract Test Suite (ATS) and partial Protocol Implementation eXtra Information for Testing (PIXIT) proforma

NGN Testing (4)

- Q.3948: Service testing framework for VoIP at NGN UNI
- Q.3949: Real-time multimedia service testing framework at the user-to-network interface of next generation networks
- Q.3950: Testing and model network architecture for tag-based identification systems and functions

G.Series specifications of testing methods

- G.650.1 Definitions and test methods for linear, deterministic attributes of single-mode fibre and cable
- G.650.2 Definitions and test methods for statistical and non-linear related attributes of single-mode fibre and cable
- G.650.3 Test methods for installed single-mode optical fibre cable links
- G.661 Definitions and test methods for the relevant generic parameters of optical amplifier devices and subsystems
- G.976 Test methods applicable to optical fibre submarine cable systems
- G.996.1 Test procedures for digital subscriber line (DSL) transceivers
- G.996.2 Single-ended line testing for digital subscriber lines (DSL)
- G.Supplement 44 Test plan to verify B-PON interoperability
- G.Supplement 46 G-PON interoperability test plan between optical line terminations and optical network units

ITU-T specifications for testing of:

Optical fibre cables

- G.652 (2009-11) Characteristics of a single-mode optical fibre and cable
- G.653 (2010-07) Characteristics of a dispersion-shifted, single-mode optical fibre and cable
- G.654 (2010-07) Characteristics of a cut-off shifted, single-mode optical fibre and cable
- G.655 (2009-11) Characteristics of a non-zero dispersion-shifted single-mode optical fibre and cable
- G.656 (2010-07) Characteristics of a fibre and cable with non-zero dispersion for wideband optical transport
- G.657 (2009-11) Characteristics of a bending-loss insensitive single-mode optical fibre and cable for the access network

Characteristics of optical components and subsystems

- G.662 (2005-07) Generic characteristics of optical amplifier devices and subsystems
- G.663 (2011-04) Application related aspects of optical amplifier devices and subsystems
- G.664 (2006-03) Optical safety procedures and requirements for optical transport systems
- G.665 (2005-01) Generic characteristics of Raman amplifiers and Raman amplified systems
- G.666 (2011-02) Characteristics of PMD compensators and PMD compensating receivers
- G.667 (2006-12) Characteristics of adaptive chromatic dispersion compensators

Optical fibre submarine cable systems

- G.973 (2010-07) Characteristics of repeaterless optical fibre submarine cable systems
- G.974 (2007-07) Characteristics of regenerative optical fibre submarine cable systems
- G.975.1 (2004-02) Forward error correction for high bit-rate DWDM submarine systems
- G.977 (2011-04) Characteristics of optically amplified optical fibre submarine cable systems
- G.978 (2010-07) Characteristics of optical fibre submarine cables

and

Coding of voice and audio signals

- G.711 (1988-11) Pulse code modulation (PCM) of voice frequencies
- G.722 (1988-11) 7 kHz audio-coding within 64 kbit/s
- G.723.1 (2006-05) Dual rate speech coder for multimedia communications transmitting at 5.3 and 6.3 kbit/s
- G.726 (1990-12) 40, 32, 24, 16 kbit/s Adaptive Differential Pulse Code Modulation (ADPCM)
- G.727 (1990-12) 5-, 4-, 3- and 2-bit/sample embedded adaptive differential pulse code modulation (ADPCM)
- G.728 (1992-09) Coding of speech at 16 kbit/s using low-delay code excited linear prediction
- G.729 (2007-01) Coding of speech at 8 kbit/s using conjugate-structure algebraic-code-excited linear prediction (CS-ACELP)

[The G.7xx speech and audio codec Recommendations contain either a set of test vectors or reference ANSI C source code that can be used to verify compliance with the Recommendation. The reference C code for Recommendations G.711 (compliance is verified in accordance with G.712), G.726, G.727, G.722 and G.728 are in the ITU-T software tools library (G.191 Annex A) and those for G.729 and G.723.1 are integral parts of those Recommendations.]

and

Coding of moving video

- H.264 (2010-03) Advanced video coding for generic audiovisual services
 - ◆ *[Conformance specification and C source code reference in H.264.1 and H.264.2.]*

Protection against interference - resistibility

- K.20 (2008-04) Resistibility of telecommunication equipment installed in a telecommunications centre to overvoltages and overcurrents
- K.21 (2008-04) Resistibility of telecommunication equipment installed in customer premises to overvoltages and overcurrents
- K.45 (2008-04) Resistibility of telecommunication equipment installed in the access and trunk networks to overvoltages and overcurrents

Voice terminal characteristics

- P.310 (2009-06) Transmission characteristics for narrow-band digital handset and headset telephones
- P.311 (2011-03) Transmission characteristics for wideband digital handset and headset telephones
- P.313 (2007-03) Transmission characteristics for cordless and mobile digital terminals

and

Image compression – JPEG 2000

- T.800 (2002-08) JPEG 2000 image coding system: Core coding system
- T.802 (2002-08) Motion JPEG-2000
 - ◆ *[T.803 defines the conformance testing of T.800 JPEG-2000 image coding. Recommendation T.802 (Motion JPEG-200) includes test vectors.*
 - ◆ *The following T.Series Recommendations are concerned with conformance testing:*
 - ◆ *T.83 – Compliance testing of digital compression and coding of continuous-tone still images;*
 - ◆ *T.834 – Conformance testing of JPEG XR still image compression; and*
 - ◆ *T.Supplement 1 – Conformance testing requirements for Recommendations in the T.170-series (multimedia and hypermedia).]*

WTSA-2008 Resolution 76

“very few of the current ITU-T Recommendations identify interoperability or conformance testing requirements”

Why so few ITU-T Test Specs?



Advancing open standards for the information society

Convergence on IP technology has led to a situation in which many standardisation organisations are involved

Example: Next Generation Networks & the IP Multimedia Subsystem (IMS)

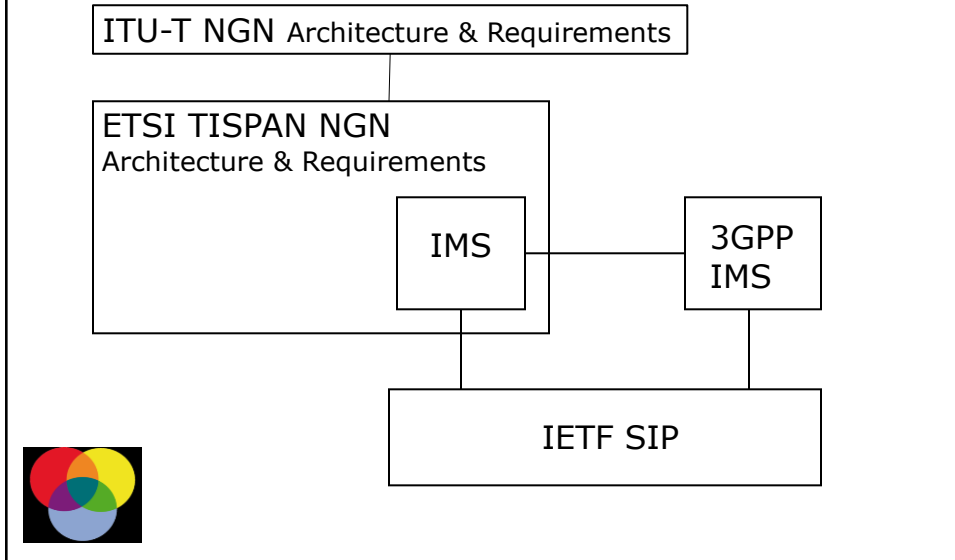

Test specifications from other SDOs (1)

- H.248 (Gateway Control Protocol)
 - *[MSF has developed some H.248 interoperability agreements]*
- H.262 (Generic coding of moving pictures and associated audio information: Video)
 - *[Conformance testing and software simulation are available in ISO/IEC 13818-4:2004 and ISO/IEC TR 13818-5:2005, respectively.]*



Test specifications from other SDOs (2)

CableLabs

- J.83 Digital multi-programme systems for television, sound and data services for cable distribution
- J.112 Transmission systems for interactive cable television services
- J.122 Second-generation transmission systems for interactive cable television services – IP cable modems
- J.125 Link privacy for cable modem implementations
- J.126 Embedded Cable Modem device specification
- J.127 Transmission protocol for multimedia webcasting over TCP/IP networks
- J.128 Set-top gateway specification for transmission systems for interactive cable television services
- J.161 Audio and video codec requirements and usage for the provision of bidirectional audio services over cable television networks using cable modems
- J.162 Network call signalling protocol for the delivery of time-critical services over cable television networks using cable modems
- J.163 Dynamic quality of service for the provision of real-time services over cable television networks using cable modems
- J.164 Event message requirements for the support of real-time services over cable television networks using cable modems
- J.166 IP-Cablecom Management Information Base (MIB) framework
- J.167 Media terminal adapter (MTA) device provisioning requirements for the delivery of real-time services over cable television networks using cable modems
- J.170 IP-Cablecom security specification
- J.171.0 IP-Cablecom trunking gateway control protocol (TGCP): Profiles overview
- J.172 IP-Cablecom management event mechanism
- J.179 IP-Cablecom support for multimedia
- J.191 IP feature package to enhance cable modems
- J.192 A residential gateway to support the delivery of cable data services
- J.199 Battery backup for cable-based devices
- J.202 Harmonization of procedural content formats for interactive TV applications
- J.204 Metrics gathering specification
- J.210 Downstream RF interface for cable modem termination systems
- J.211 Timing interface for cable modem termination systems
- J.212 Downstream external Physical layer interface for modular cable modem termination systems
- J.215 Client digital program insertion API

Test specifications from other SDOs (3)

CableLabs (continued)

- J.222.1 Third-generation transmission systems for interactive cable television services – IP cable modems: Physical layer specification
- J.222.2 Third-generation transmission systems for interactive cable television services – IP cable modems: MAC and Upper Layer protocols
- J.222.3 Third-generation transmission systems for interactive cable television services – IP cable modems: Security services
- J.361 IP-Cablecom2 codec and media
- J.365 IP-Cablecom2 application manager interface
- J.366.0 IP-Cablecom2 IP Multimedia Subsystem (IMS): Delta Recommendations overview
- J.366.2 IP-Cablecom2 IP Multimedia Subsystem (IMS): Session handling – IM call model – Stage 2 specification
- J.366.3 IP-Cablecom2 IP Multimedia Subsystem (IMS): Stage 2 specification
- J.366.4 IP-Cablecom2 IP Multimedia Subsystem (IMS): Session Initiation Protocol (SIP) and Session Description Protocol (SDP) – Stage 3 specification
- J.366.7 IP-Cablecom2 IP Multimedia Subsystem (IMS): Access security for IP-based services
- J.366.8 IP-Cablecom2 IP Multimedia Subsystem (IMS): Network domain security specification
- J.366.9 IP-Cablecom2 IP Multimedia Subsystem (IMS): Generic authentication architecture specification (3GPP TS 33.220)
- J.368 IP-Cablecom2 quality of service specification
- J.369 IP-Cablecom2 E-UE provisioning framework specification
- J.370 IP-Cablecom2 embedded user equipment provisioning data model specification
- J.602 Network service operator's requirements for real-time transmission of exLSDI signals under parallel processing functionality

Test specifications from other SDOs (4) Broadband Forum

- G.991.2 Single-pair high-speed digital subscriber line (SHDSL) transceivers
- G.992.1 Asymmetric digital subscriber line (ADSL) transceivers
- G.992.2 Splitterless asymmetric digital subscriber line (ADSL) transceivers
- G.992.3 Asymmetric digital subscriber line transceivers 2 (ADSL2)
- G.992.5 Asymmetric digital subscriber line (ADSL) transceivers – Extended bandwidth ADSL2 (ADSL2plus)
- G.993.2 Very high speed digital subscriber line transceivers 2 (VDSL2)
- G.994.1 Handshake procedures for digital subscriber line (DSL) transceivers
- G.997.1 Physical layer management for digital subscriber line (DSL) transceivers

National Standardisation

■ Example

- NICC (UK) Ethernet Active Line Access (ALA)

Mandatory Conformity Assessment

Examples

- USA
- Canada
- EU

USA

- The FCC oversees the authorization of equipment using the radio frequency spectrum in the USA [<http://transition.fcc.gov/oet/ea/>].
- Such equipment may not be imported or marketed unless it meets the technical standards specified by the FCC. Depending upon its capabilities equipment may be subject to:
 - **verification** (in which manufacturers test the device),
 - **declaration of conformity** (which requires testing by an accredited test laboratory) or
 - **certification** (which is issued by the FCC or a designated Telecommunications Certification Body based on test results submitted by the supplier).
- FCC provides a database on equipment authorisations
 - [<https://apps.fcc.gov/oetcf/eas/reports/GenericSearch.cfm>]

Canada

- The Certification and Engineering Bureau of Industry Canada [<http://www.ic.gc.ca/eic/site/ceb-bhst.nsf/eng/Home>] provides a certification service for radio and terminal equipment in Canada.
- The Industry Canada Certification and Engineering Bureau maintain lists of terminal equipment http://www.ic.gc.ca/eic/site/ceb-bhst.nsf/eng/h_tt00050.html and radio equipment http://www.ic.gc.ca/eic/site/ceb-bhst.nsf/eng/h_tt00020.html that has been certified for use in Canada.

European Union

- The Radio and Telecommunications Terminal Equipment (R&TTE) Directive (1999/5/EC) [http://ec.europa.eu/enterprise/sectors/rtte/index_en.htm] defines a harmonised regulatory framework for the approval of terminal equipment in the European Union.
- It is based on supplier declaration of conformity to basic requirements intended to ensure that the equipment is safe to use and does not cause interference with other equipment.
- The Croatian Post and Electronic Communications Agency provides a database of equipment approved in accordance with the EU R&TTE directive [<http://www.hakom.hr/default.aspx?id=561>]

Conclusions / Summary

- Traditional telecommunications standardisation process has been impacted by:
 - ◆ Liberalisation (introduction of competition)
 - ◆ Technological change (especially Internet)
- But standardisation is still necessary at a regional or national level to ensure:
 - ◆ Safety
 - ◆ No harm to network
 - ◆ Effective competition
 - or
 - ◆ If no international standard is available

Thank You!

keith.mainwaring@ukrainsystems.com