



RECEIVABILITY OF THE SPACE NOTICES

Attila MATAS
Head, SPR - BR/SSD

International Telecommunication Union

WORLD
RADIOCOMMUNICATION
SEMINAR 2014

GENEVA, 8-12 DECEMBER 2014

www.itu.int/go/ITU-R/WRS-14

Organised by:

150 1865 2015

ITU

ITU

ITU

The poster features a photograph of the Jet d'Eau fountain in Geneva, Switzerland, set against a blue sky and a cityscape. The bottom half of the poster is red and contains the ITU logo, the event title, dates, website, and anniversary information.

RECEIVABILITY OF THE NOTICES

- **Entry examination of the notice received by the Bureau**
 - Submission of information in electronic format (**RES 55**)
 - Application of the Radio Regulations (RR)
<http://www.itu.int/pub/R-REG-RR/en>
 - Application of the Rules of Procedures (RoP)
<http://www.itu.int/pub/R-REG-ROP/en>
concerning the **Receivability** of forms of notice
 - **its completeness** (Annex 2 of AP 4) and
 - **its correctness** - **use of the BR validation software by the ADM**
- **Result of the entry examination**
 - **Acknowledgment** by the Bureau
 - Confirmation of the Bureau registry date - establishment of the **formal regulatory date of receipt**

RECEIVABILITY OF THE NOTICES

Basic ROP related to the Receipt of notices - BR registry date

- **ROP 2** - *It is incumbent on all ADM to meet deadlines established in the RR and, accordingly, to take account of possible mail delays, holidays or periods during which ITU may be closed. (see the latest **CR/395**)*

ITU-R CR letters: <http://www.itu.int/md/R00-CR-CIR/en>

- Mail received through the postal service shall be recorded as received on the first working day following period of closure
 - E-mail or telefax documents shall be recorded as received on the actual date of receipt
 - *In the case of E-mails, an administration is required to send, within 7 days of the date of the E-mail, a confirmation by either telefax or mail which shall be regarded as being received on the same date as the original E-mail.*
- ❖ *Administration shall not use the BR staff E-mail address for submission of their notices to the BR Registry.*

Basic ROP related to submission of the notices

- All mail must be sent to the following address:
ITU Radiocommunication Bureau
Place des Nations
CH-1211 Geneva 20
Switzerland
- All telefaxes must be sent to: **+41 22 730 5785** (several lines)
- All E-mail must be sent to: ***brmail@itu.int***
 - Information received in the BR Registry by E-mail shall be acknowledged immediately by E-mail from the BR mail server
- ❖ **As of xx.2015 API submission** subject to coordination procedure under Section II of Article 9, **shall be made exclusively via the ITU web interface SpaceWISC:**
<https://extranet.itu.int/itu-r/spacewisc>
- **For more information see:**
<http://www.itu.int/go/spacewisc>

RECEIVABILITY OF THE NOTICES

Communication problems with the BR registry?

- Official e-mail address for receiving communication from the Bureau in case of communication problems
see CR/366
- The Bureau has been facing difficulties in informing administrations of its actions in application of the Radio Regulations through telefaxes. The telefax could not be successfully sent to some administrations when using the telefax numbers which have been formally communicated to the Bureau. *Under this circumstance, the Bureau has no other option than to send the same information by surface mail.*
- In addition to the surface mail, *the Bureau is ready to send an e-mail with PDF attachment (scanned telefax) to all administrations whose official e-mail address has been communicated to the Bureau* whenever the communication through telefax would not be successful
- *Correspondences to be sent by administrations to the Bureau should continue to use telefax or surface mail* except the cases where a request for electronic format communication is mentioned in the RR or in the RoP

Establishment of Date of Receipt (1)

- If a notice does not contain all of the mandatory information as defined in the AP 4 of the RR, or for example - the email from ADM is without attached data or a letter with an empty CD-ROM etc..., further processing of the notice will remain in abeyance and a date of receipt will not be established until the missing information is received
- If all mandatory data have been submitted and further clarification is required concerning the correctness of the mandatory data, the Bureau shall request the ADM to provide the clarification within 30 days
- If the information is received within the 30 days period, the original date of receipt is retained, otherwise, a new date of receipt will be established

Establishment of Date of Receipt (2)

- Nevertheless, for replies received within the above period of 30 days, **a new formal date of receipt (and cost recovery)** is established in those cases (or for the concerned part of the network) where the information submitted subsequently is **outside the scope and beyond the objective** of the Bureau's enquiry, if the **new or modified data has impact on the regulatory and technical examination**, irrespective of whether the newly provided information adds new affected administrations or not.

Establishment of Date of Receipt (3)

- When a *Coordination request* or *Notification* is communicated to the BR at the same time as the **API**, the **formal date of receipt** of this information (No. **9.1**) is established as follows:
 - For the Assignments that require coordination under Sect II of Article **9**
 - 6 months after the **date of receipt** of **API**
 - For the Assignments that do not require coordination under Sect II of Article **9**
 - 6 months after the **date of publication** of **API**

List of "as received"

- Coordination Requests or Notifications
"as received" are made available by the BR within 30 days (RES **55**)
 - BR IFIC (Space services) DVD-ROM
 - This information can also be monitored through the ITU website ITU → Radiocommunication → Space Services → BR IFIC → List of information "as received" → **SNL PART-C** at:
<http://www.itu.int/ITU-R/space/snl/>
 - This advance version of the information received from the ADM is not to be confused with the official publication of the relevant PART or Special section which is yet to occur

Processing of Satellite Network Filings - *RECEIVABILITY*

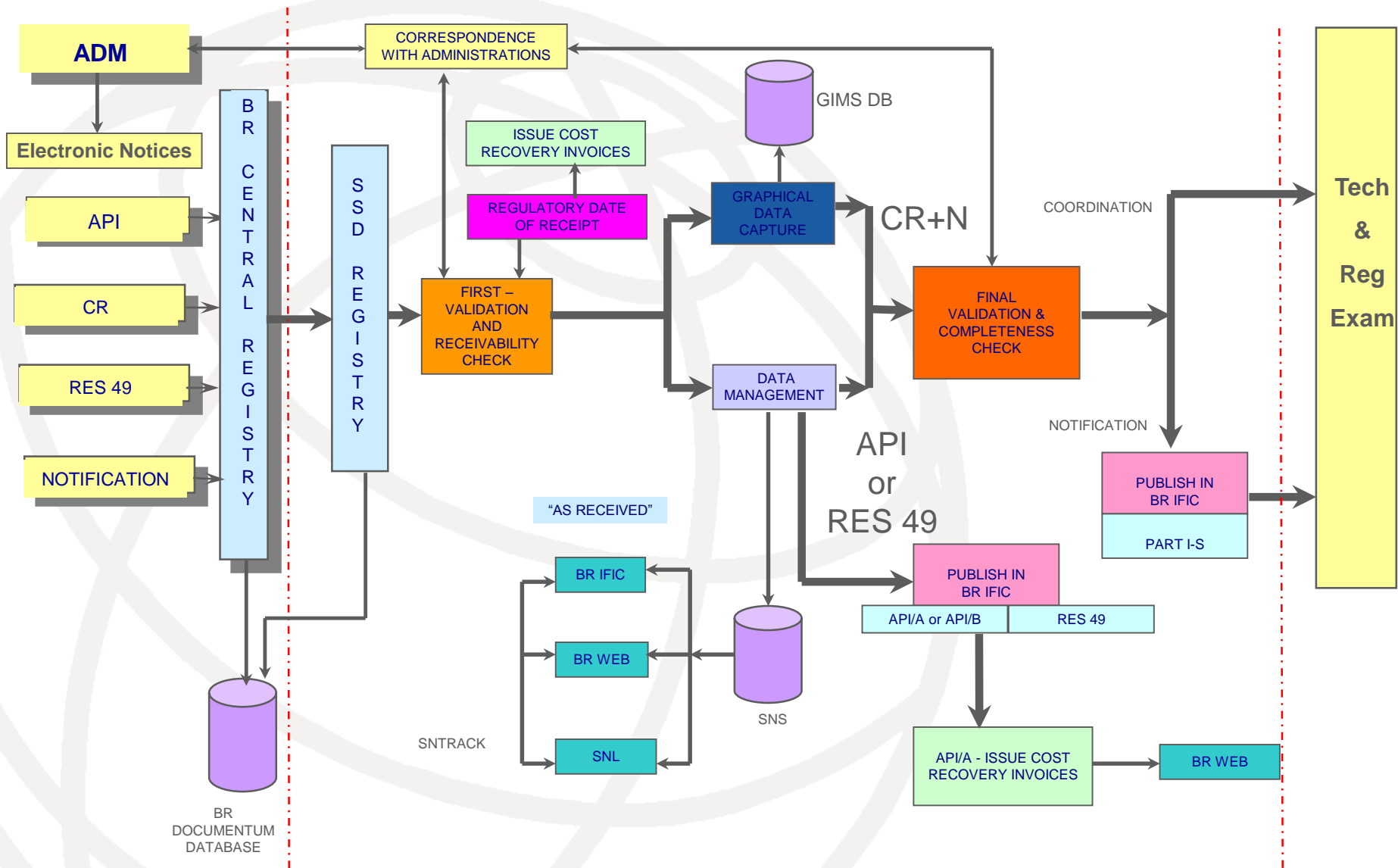

Processing of Satellite Network Filings – *PUBLICATION*

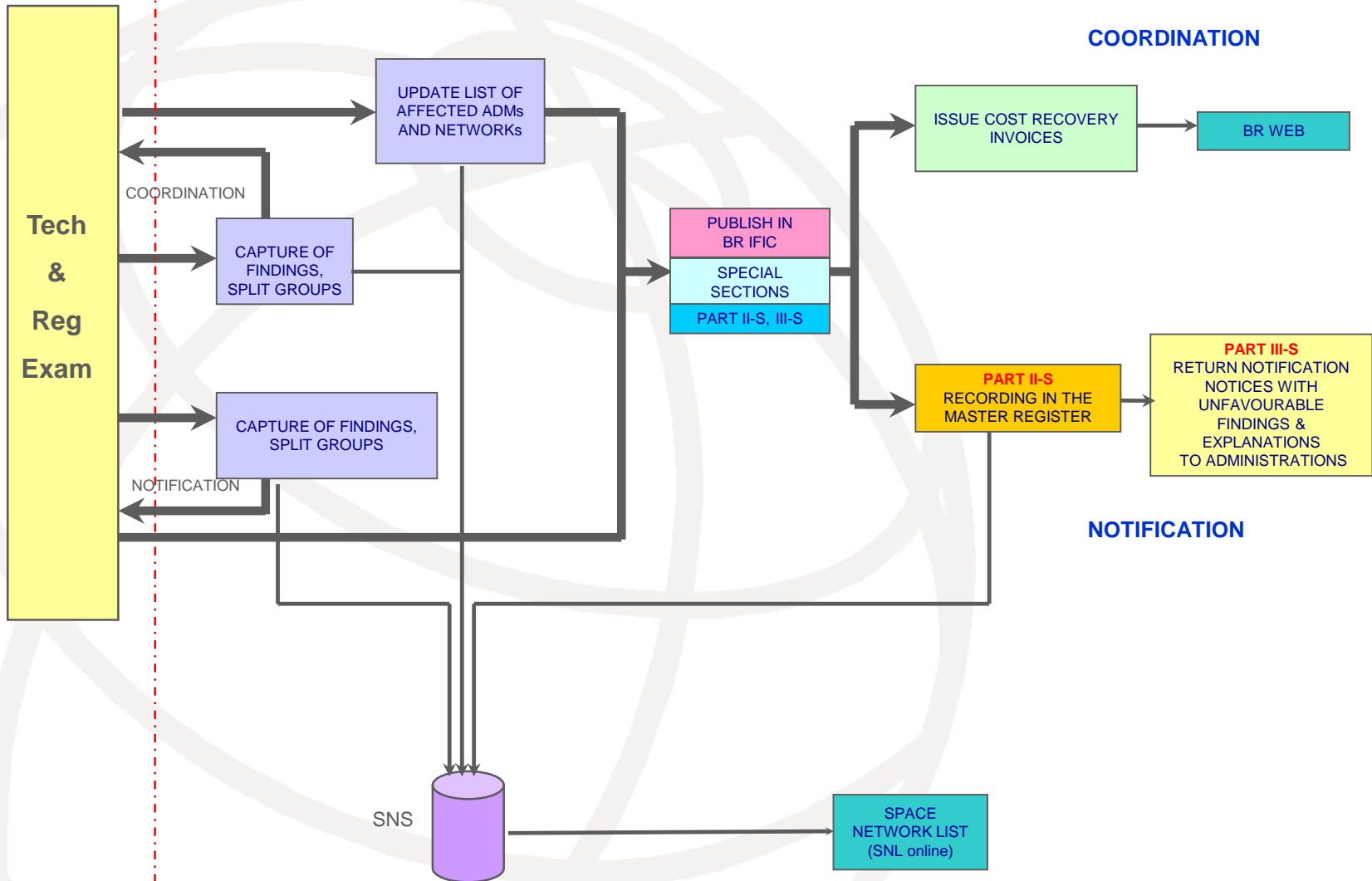

API (1)

- API phase is ***obligatory***, before coordination phase or notification
- No priority in being first to start advance publication
- ***Formal date of receipt of the API*** (No.9.1) starts the "***regulatory clock***" – ***Ds***
- Where to find the Formal Date of Receipt?

API publication



Ds

UNION INTERNATIONALE DES TELECOMMUNICATIONS
BUREAU DES RADIOCOMMUNICATIONS

INTERNATIONAL TELECOMMUNICATION UNION
RADIOCOMMUNICATION BUREAU

UNION INTERNACIONAL DE TELECOMUNICACIONES
OFICINA DE RADIOCOMUNICACIONES

IFIC / DATE IFIC / DATE IFIC / FECHA	2460 / 08.01.2002	SECTION SPECIALE N° SPECIAL SECTION No. SECCIÓN ESPECIAL N.º	API/A/832 MOD-1
RESEAU(X) A SATELLITE SATELLITE NETWORK(S) RED(ES) DE SATÉLITE	ROSCOM-2	ADMINISTRATION RESPONSABLE RESPONSIBLE ADMINISTRATION ADMINISTRACIÓN RESPONSABLE	RUS
RENSEIGNEMENTS REÇUS PAR LE BUREAU LE INFORMATION RECEIVED BY THE BUREAU ON INFORMACIÓN RECIBIDA POR LA OFICINA EL		21.11.2001	

Ces renseignements concernant les réseaux à satellite régis par l'article S9, sous-section 1B, sont publiés par le Bureau des radiocommunications en application du No. S9.2B. Ils font l'objet de la(les) procédure(s) suivante(s), indiquée(s) ci-dessous par un X dans la case pertinente.
(voir les commentaires du Bureau des radiocommunications)

This information on satellite networks covered under Article S9, Sub-Section 1B, is published by the Radiocommunication Bureau in accordance with No. S9.2B. It is subject to the procedure(s) indicated below by an X in the relevant box.
(see comments of the Radiocommunication Bureau)

Esta información relativa a las redes de satélite regidas por el Artículo S9, sub-sección 1B, se publica por la Oficina de Radiocomunicaciones en virtud del No. S9.2B. Está sujeta al (los) procedimiento(s) siguiente(s), señalado(s) con una X en la casilla apropiada.
(véanse las observaciones de la Oficina de Radiocomunicaciones)

<input type="checkbox"/>	Les renseignements ont été reçus conformément au No. S9.1	The information has been received pursuant to No. S9.1	La información ha sido recibida de conformidad con No. S9.1
<input checked="" type="checkbox"/>	Les renseignements ont été reçus conformément au No. S9.2	The information has been received pursuant to No. S9.2	La información ha sido recibida de conformidad con No. S9.2
	Toute administration estimant que ses réseaux à satellite, ses systèmes à satellites ou ses stations de terre, selon le cas, existants ou en projet, sont affectés, peut envoyer ses observations à l'administration qui a demandé la publication des renseignements, avec copie au Bureau des radiocommunications.	Any administration which considers that its existing or planned satellite systems or networks or terrestrial stations, as appropriate, are affected, may send its comments to the administration which has requested publication of the information, with a copy of such comments to the Radiocommunication Bureau.	Cualquier administración que considere que sus sistemas o redes de satélites o estaciones terrenales, según el caso, existentes o planificados se verán afectados, podrá comunicar sus comentarios a la administración que haya solicitado la publicación de la información, enviando una copia de dichos comentarios a la Oficina de Radiocomunicaciones.

Information aussi disponible sur le / Information also available on the / Información también disponible en:

Space Network Systems Online Service : <http://www.br/sns/advpub.html>

© I.T.U.

RECEIVABILITY OF THE NOTICES

API (2)

- Relevant Rules of Procedure (ROP) on *Receivability*
 - **1**: electronic filing (*resolves 5 of RES55*)
 - **3.2**: **completeness** (Annex 2 of AP **4**) and **correctness** of the information
 - **3.4**: Administrations are encouraged to run the validation software themselves in order to overcome any difficulties in the notices before they are submitted to the Bureau.

- Select the proper notice form
 - AP4/V: coordination not required (non-GEO)
 - AP4/VI: coordination required (GEO, non-GEO)
 - [mixed]

RECEIVABILITY OF THE NOTICES

API (3)

- Submission of MOD is requiring that the **API** have to be recorded with a

new date of receipt (No. 9.2):

- for *new frequency band(s)*
- for a change of GSO orbital location by *more than +/- 6 degrees*
- if *no CR within 24 months* from **API** receipt (No. **9.5D** apply)
- for **API** where coordination is not required by Section II of Article **9**, the *modification of the reference body* or the *modification of the direction of transmission for a space station using a non-GEO satellite orbit (WRC-12)*

RECEIVABILITY OF THE NOTICES

Coordination Request - CR (1)

- No. **9.1** - CR shall be considered as having been received not earlier than 6 months after date of reception of the **API**
- No. **9.2** - Check if the CR frequency bands are covered by the **API**. If **no**, *will require the application of the API for this band and new CR date +6 months (and cost recovery)*
- No. **9.2** - Check modification of the orbital position whether *not more than +/-6 degrees* vis-à-vis the **API**

RECEIVABILITY OF THE NOTICES

Coordination Request - CR (2)

Time Limit *check* of No. 9.5D

- Coordination information (No. **9.30**) must be sent within **24 Months** from the formal date of Receipt of API in BR (Ds)
- BR sends a reminder (CT ITU), 3 months before the end of the regulatory date
- If received beyond the Time Limit, BR will cancel the API. If the administration wishes the Coordination information will be considered as a new API and Coordination data sent at the same time (RoP under No. **9.5D**)

RECEIVABILITY OF THE NOTICES

Frequency Vs Time (Limit) - No.9.5D

For **part of the band** not covered by the CR/C within 24 months - Start API fresh before submitting Coordination information.

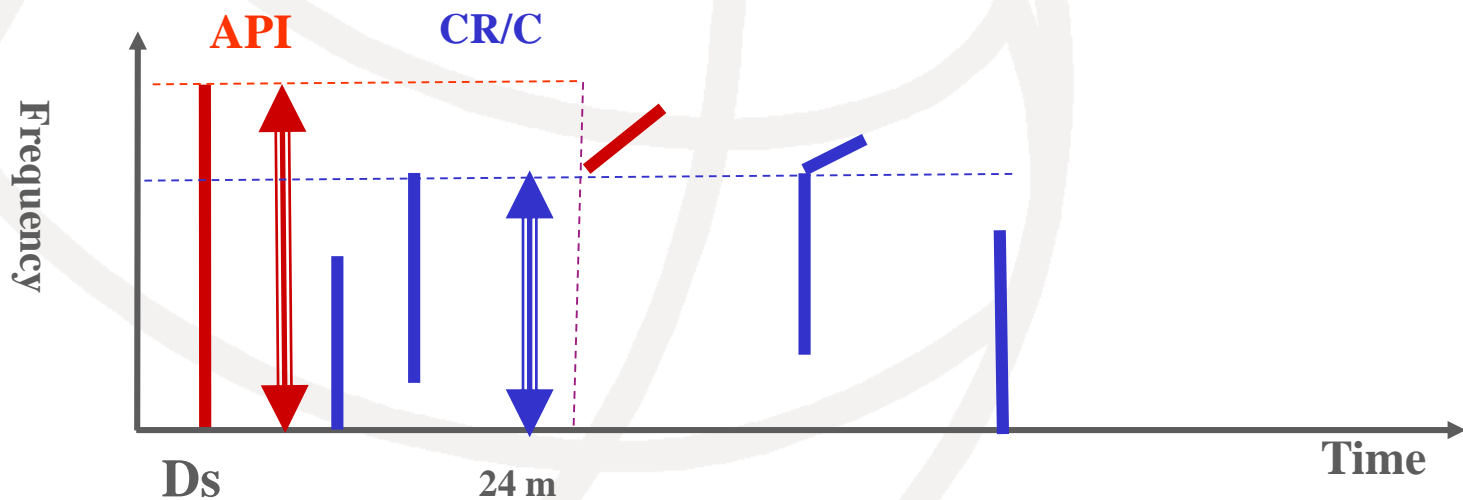

RECEIVABILITY OF THE NOTICES

Coordination Request - CR (3)

- **Validation of graphical data**
 - ART **5** (Regional service area restrictions)
 - Steerable beams (No. **1.191**, AP4 B.3.b)
 - The maximum co-polar isotropic gain is required where a steerable beam is used
 - GSO diagrams (AP4 B.3.e)
 - if the space station is operating in a band allocated in the Earth-to-space direction and in the space-to-Earth direction
 - Check with respect to **ROP**
 - No. **21.16** – PFD limits for steerable beams
 - No. **23.13** - Disagreement by and ADM on the inclusion of its territory in the service area of a BSS (except sound broadcasting) network

Notification (1)

- Notification **not** earlier than ***3 years before dBiU*** (No. **11.25**)
- Relevant AP4 data have to be provided – see No. **11.15** (WRC-07) – RES-55 apply. **No more “only changes” to No. 9.29 (CR)**
- **ROP 4.3** multiple procedures (**API – (C) – N**)
 - previously applicable procedures have to be effected
 - for earth station: associated space station supported by an **API**
 - assignments that require coordination under Sect II of Article **9** is not supported by a publication of coordination request (CR/C)
 - assignments that do not require coordination under Sect II of Article **9** is not supported by an **API**

Notification (2) - Publication of Complete Notification

- Complete notices are published in **PART I-S** of the BR IFIC (Space services) with the date of receipt. **This publication shall constitute the acknowledgement to the notifying ADM of receipt of its notice.**
- PART I-S notices will be used for further technical and regulatory examination by the Bureau

RECEIVABILITY OF THE NOTICES

Time Limit under RES49

- *ADM shall submit Space Craft Manufacturer and Launch Service provider details with frequency bands... **Before** = **Ds + 7 years**;*
or
- **Before** the date of bringing into use if notified earlier (para 12 of Annex 1 of RES49)
- **In the absence of RES49 information beyond 7 years notice will become unreceivable; or provisional recording will be deleted and assignments will not be taken into account by BR and Administrations (para 11 of Annex 1 of RES49)**
- BR Sends Reminders 6 month before this date

RECEIVABILITY OF THE NOTICES

Frequency vs Time (Limits) Nos. 11.44/11.44.1/RS49

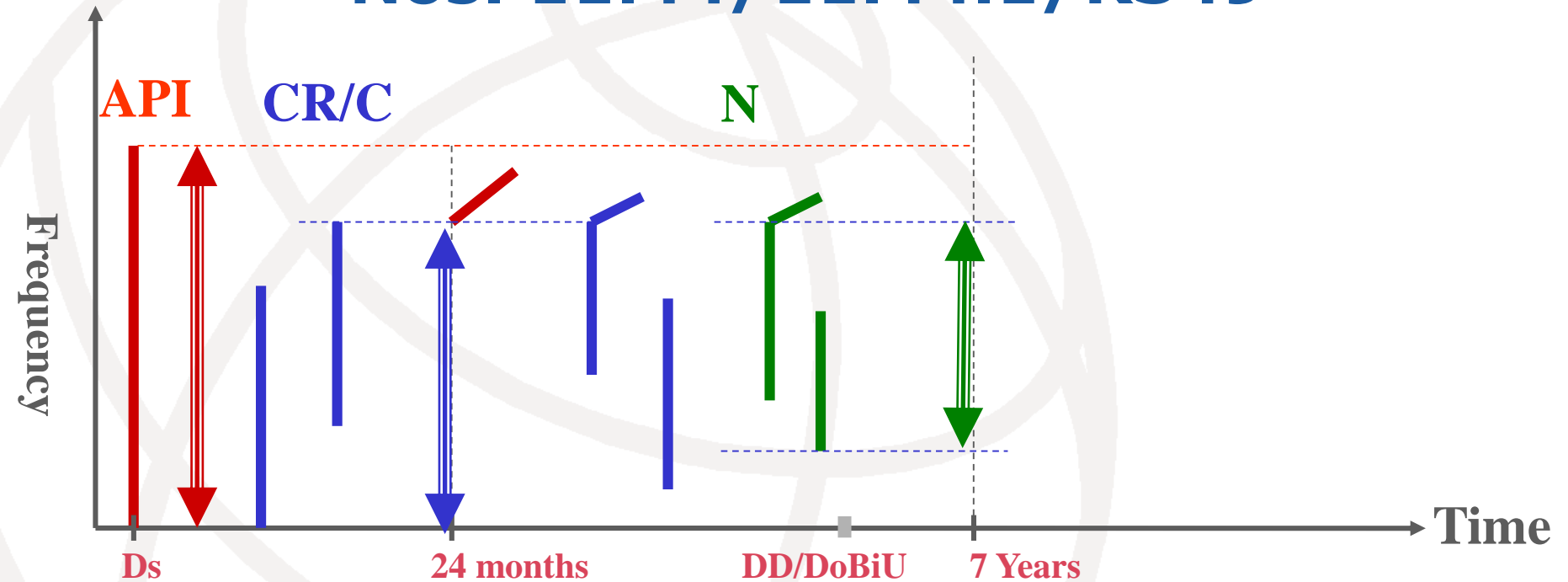

Time Limit for Resubmission No. 11.46

- Date before which Notice has to be Resubmitted after return by the BR in the PART III-S under Nos. **11.37/11.38**

= **Dr** (Date stamped on the Return letter by BR) + **6 months**

- **If resubmitted after 6 months BR advises to restart API procedure when** period for submission under No. **11.44.1** of first notice **has expired**



Time Limit for Resubmission Under No. 11.46

- If resubmitted after 6 months it will be treated as first submission (cost recovery fee) and shall comply with provisions of No. 11.44.1
- The submission is accepted as valid first Notice **ONLY** within 7 year period

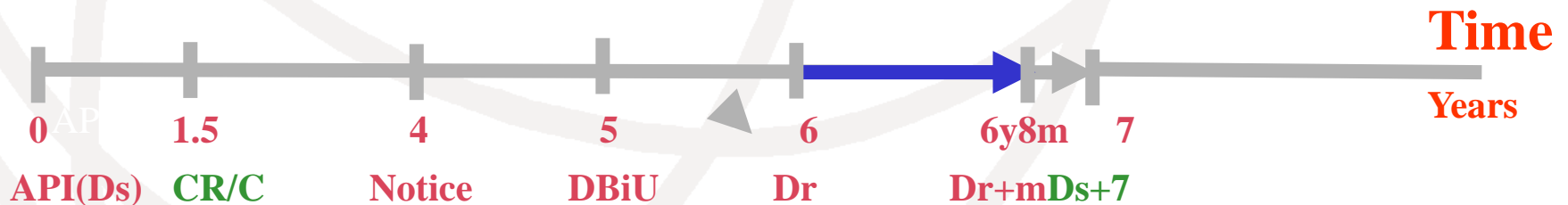

RECEIVABILITY OF THE NOTICES

RECAPITULATION -Time Limits

- BR SNS online HELP - **query/view the critical *regulatory dates*** for a selected satellite network
 - ***Date of receipt*** of the **API** - "***regulatory clock***"
 - ***Frequency bands*** published in the **API(s)**
 - CR ***due date*** (No. **9.5D**)
 - Notified ***date of bringing into use*** - "***final***" regulatory date (Nos. **11.44, 11.44.1**)

RECEIVABILITY OF THE NOTICES

RECAPITULATION (3) -Time Limits

BR SNS Online HELP - API regulatory dates summary:

<http://www.itu.int/sns/advpub.html>

SUMMARY INFORMATION						
Satellite name	Longitude	Category	Adm	Ntwk Org	Provn	Date of receipt of last modification by Adm
USOBO-8	87.500	A	USA	-	9.1/IB	23.09.2003
Download notice into MS/ACCESS	<input type="text" value="2000"/>	<input type="button" value="GO"/>	<input type="button" value="?"/>			

Download results to:



table/worksheet:
api_geo_sum

DETAILED INFORMATION

DATE OF RECEIPT	FREQUENCY FROM [MHz]	FREQUENCY TO [MHz]	CLASS OF STATION	NATURE OF SERVICE	PLANNED DATE OF BRINGING INTO USE	SERVICE AREA	IFIC/WIC NBR	H DATE (CR DUE DATE 9.5D)	G DATE REGULATORY DEADLINE 11.44, 11.44.1
15.06.2001	1215.6	1239.6	EN	CO	02.05.2006	SPACE-TO-SPACE	2517	15.06.2003	15.06.2008
15.06.2001	1563.42	1587.42	EN	CO	02.05.2006	SPACE-TO-SPACE	2517	15.06.2003	15.06.2008
03.05.1999	1750	1850	EK	CO	02.05.2006	GUM	2517	03.05.2001	03.05.2006
03.05.1999	2200	2230	ER	CO	02.05.2006	MWM	2517	03.05.2001	03.05.2006
23.09.2003	2230	2235	ER	CO	02.05.2006	MWM	2537	23.09.2005	23.09.2010
03.05.1999	2235	2290	ER	CO	02.05.2006	MWM	2517	03.05.2001	03.05.2006
03.05.1999	20200	21200	EI	CO	02.05.2006	MWM	2517	03.05.2001	03.05.2006
03.05.1999	43300	45500	EI	CO	02.05.2006	MWM	2517	03.05.2001	03.05.2006

RECEIVABILITY OF THE NOTICES

Recapitulation - Time Limits

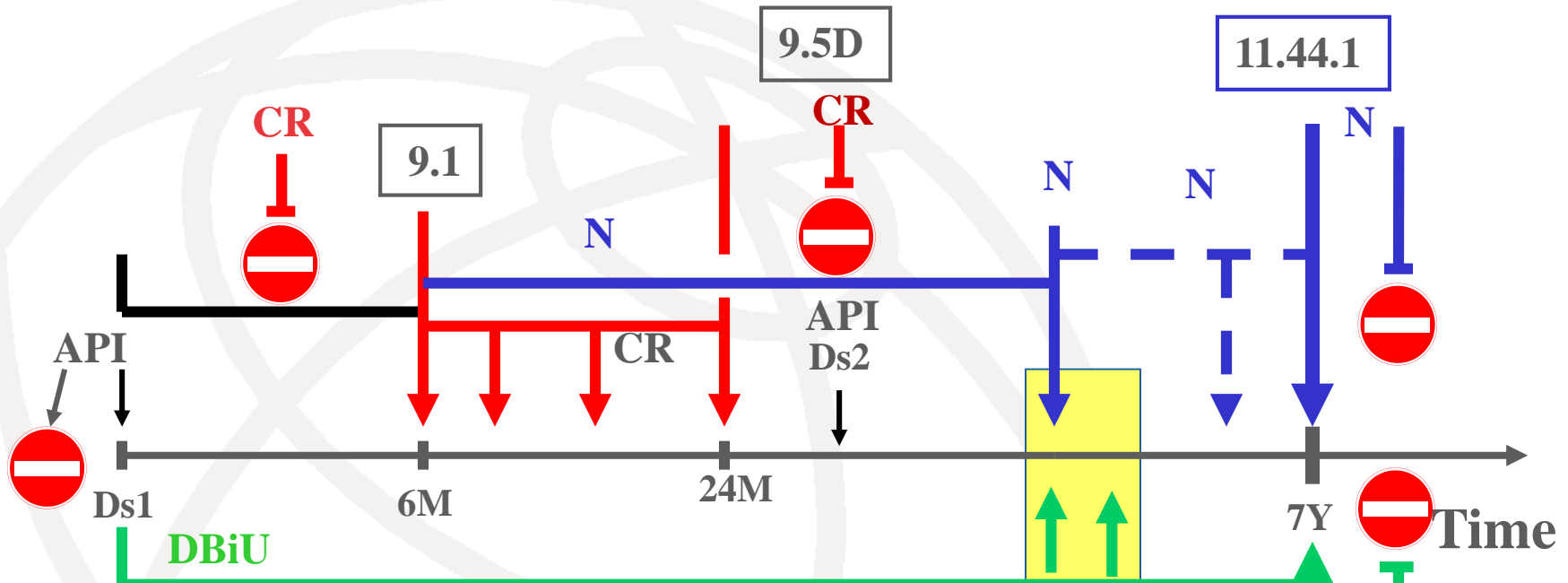

API – Advance Publication of Info

CR – Coordination Request (Art. 9)

N – Notification (Art. 11)

DBiU –Date of Bringing into Use

DD – Due Diligence

Conclusions 1

- It is and take extremely important to keep track action *within the Time Limits* for your networks.
- *Valuable time will be lost (and cost recovery fee)* in applying the procedure all over again ***if the time limits are not respected***
- BR may send telefax and Circular Telegrams to remind administrations

Conclusions 2

- However, **administrations are strongly encouraged** to keep track of the regulatory Time Limit, **on their own**, without waiting for the reminder from BR
- The Board may not accept non-receipt of reminders as a good reason for consideration.
- The BR is now posting only CTs and **not individual telefaxes** on the WEB in the following address:
<http://www.itu.int/md/R00-CTITU-CIR/en>

RECEIVABILITY OF THE NOTICES

Attila MATAS

BR SSD-SPR

Questions ?