



valladoli+D
adelante AGENCIA DE INNOVACIÓN
Y DESARROLLO ECONÓMICO
DE VALLADOLID

SUSTAINABLE MOBILITY

Jeronimo Hinojosa

Técnico Superior de Gestión de Proyectos Smart City

jhinojosa@ava.es







03 **Octubre** 2019

9^a Semana de las **Normas Verdes**
1-4 Octubre 2019
VALENCIA, ESPAÑA

Conectando las
ciudades inteligentes y sostenibles
con los
Objetivos de Desarrollo Sostenible

AGENDA

-  RECI: GTIV: Movilidad Sostenible
-  Valladolid: Planes estratégicos
-  Valladolid: Proyectos de Innovación
-  **ODS: la transformación ineludible.**

Estrategia Española de Desarrollo Sostenible

Movilidad Sostenible ↔ REMOURBAN

GT4-SubGT1 PLATAFORMAS INTELIGENTES E INFRAESTRUCTURAS	GT4S1_01 BIGDATA	GT4S1_01	Datos Abiertos. Desarrollo del portal multimodal de datos abiertos del Transporte (Alineado con el Plan Nacional del Transporte)
		GT4S1_02	Caracterización de Fuentes de Datos en Transporte (Resultados proyecto TT)
	SGT4_02 MODELIZACIÓN Y PREDICCIÓN	GT4S1_03	Proyecto piloto de modelo predictivo de demanda de transporte
	GT4S1_03 IoT	GT4S1_04	Despliegue de plataformas IoT. Experiencias (Lugo, Valencia, Las Palmas, ...)

GT4-SubGT2 EFICIENCIA Y SOSTENIBILIDAD	GT4S2_01 Descarbonización	GT4S2_01	Plan del Grupo Fomento para la Infraestructura del Vehículo Eléctrico y otros Vehículos con Energías Alternativas (Piloto del Plan Nacional del Transporte)
	GT4S2_02 Restricciones por contaminación.	GT4S2_02	Experiencias MADRID y VALLADOLID

GT4-SubGT3 POLÍTICAS, REGULACIÓN NORMATIVA	GT4S3_01 VMP	GT4S3_01	Transposición DGT – Instrucción 16/V-124 a EELL
		GT4S3_02	Ordenanzas: Caso MADRID / Sevilla /...
	GT4S3_02 Logística y Mercancías	GT4S3_03	Implantación de Soluciones (TIC) en última milla (Área DUM, Valladolid, ...)

Valladolid de un vistazo

Valladolid is the capital city of **Castilla y Leon**, a Region in the Northwest part of Spain.

Población: 302,884 habitantes (415.000 en zona metropolitana)

Historia: fundada en 1072, cuenta con una dilatada y rica historia

Location of the Province of Valladolid Location of the city of Valladolid

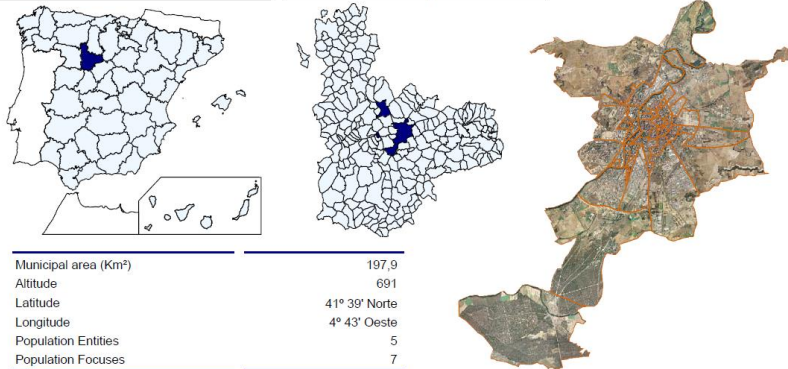

Estructura de la población

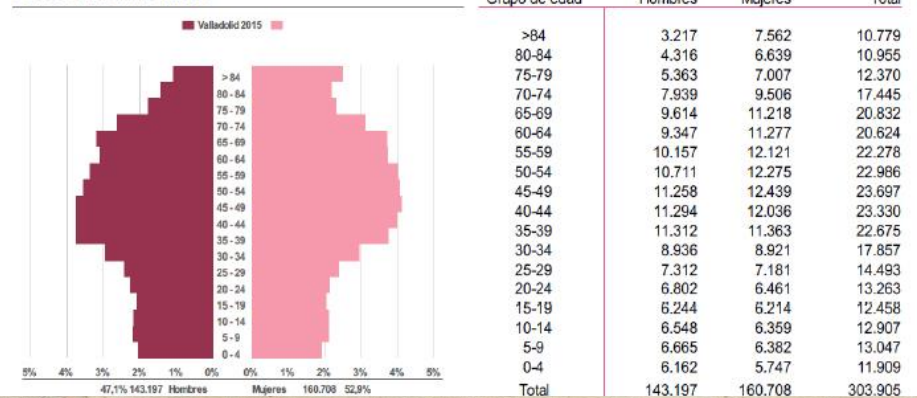

ECOSISTEMA DE INNOVACIÓN

PLACES

GREEN CITY

- Urban Mobility Centre
- Bike-Sharing: VALLABICI
- Sustainable Mobility



INSPIRING PLACES

- Millenium Square
- Valladolid. Rivers of Light

EASY ACCESS

- "Eliminando Barreras—Incluyendo personas"

CULTURAL INNOVATION

- Valladolid's Arts Laboratory
- CreART project



PEOPLE

SOCIAL INNOVATION

- Software Developer Community
- OLIDLAB. Living Lab
- INTERACTIVE PEOPLE



CDIT—Municipal Centre for the Promotion of Technology
 O-GOVERNMENT: www.valladolid.gob.es
 Urban Observatory—Open Data: www.valladolidencifras.es



INNOVATION AGENCY: OPEN TO CITIZEN

- Job Opportunities: Training and networking, Helping people into work
- Permanent headquarters: "Fundación Wikimedia España", "Amigos de Renault", "FILIN"

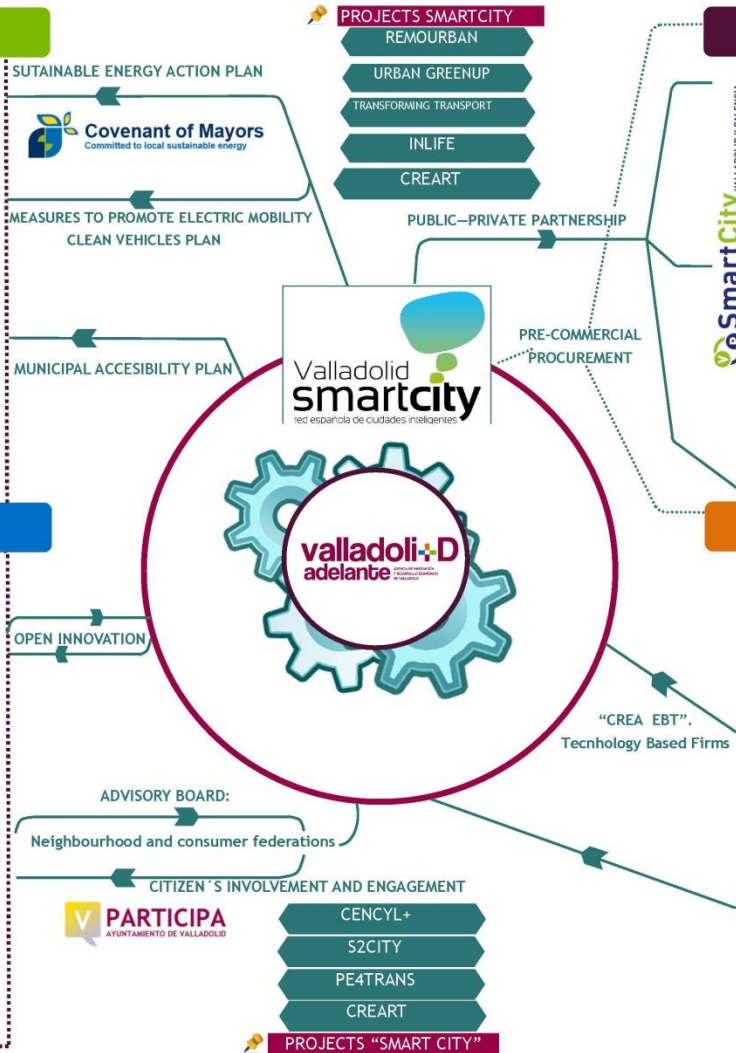

PRIVATE

GLOBAL CORPORATIONS



AND MORE

SMES



AND MORE

ENTREPRENEURSHIP "CREA"

- Places for development business ideas
- Integral Assistance and Support
- Financing

PUBLIC

RESEARCH & INNOVATION CENTRE



UNIVERSITY OF VALLADOLID



SCIENCE CENTRE



PROYECTOS DE INNOVACIÓN: EVOLUCIÓN

ANTECEDENTES

INTEGRATED SUSTAINABLE URBAN DEVELOPMENT STRATEGY

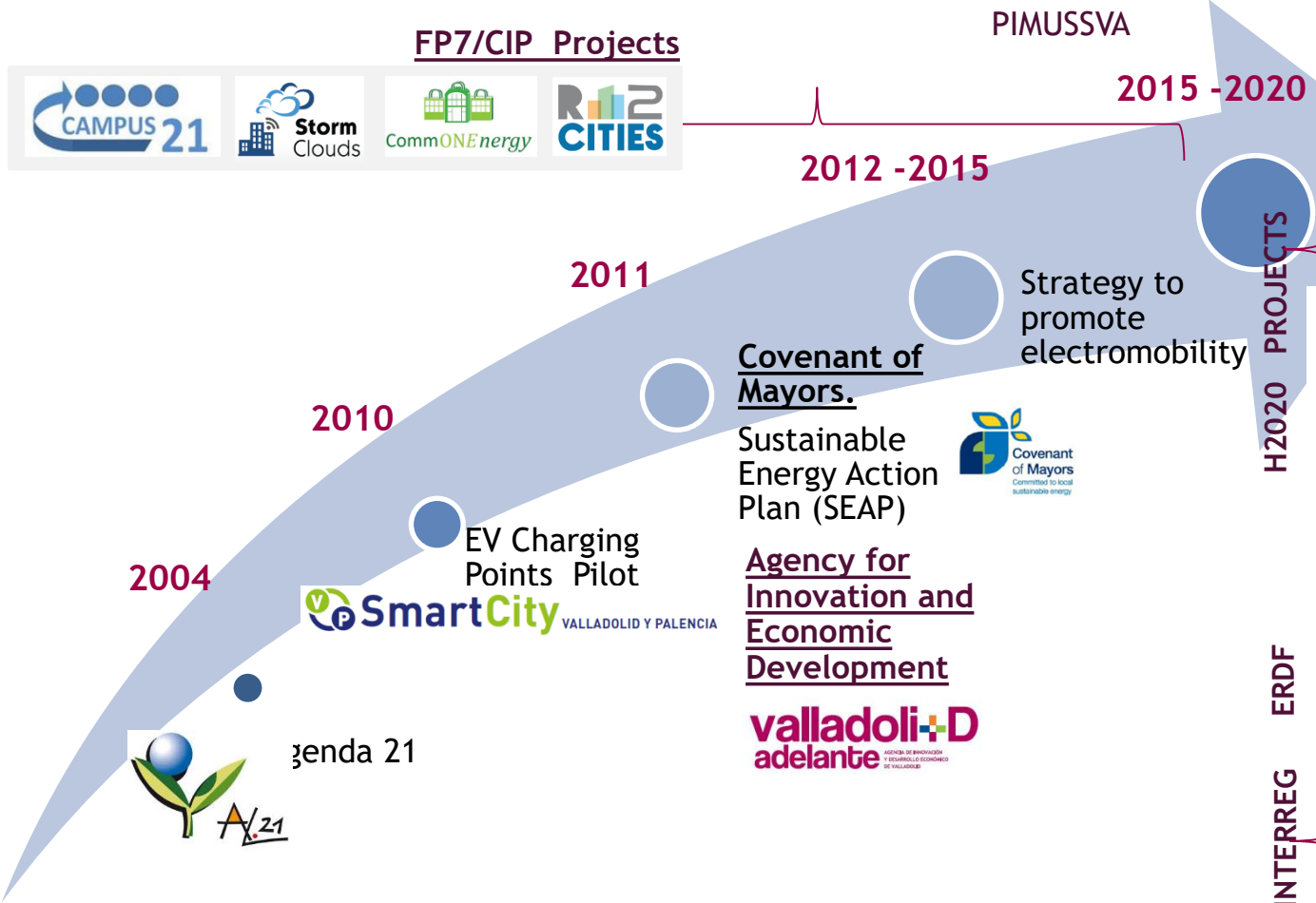

H2020 PROJECTS

REMO URBAN
Lighthouse
H2020-SCC-2014-2015: Smart Cities and Communities
H2020-SCC-02-2016-2017- Demonstrating innovative nature-based solutions in cities
H2020-ICT-15-2016-2017- Big Data PPP: Large Scale Pilot actions in sectors best benefitting from data-driven innovation

URBAN GREEN UP
TRANSFORMING TRANSPORT
H2020-ICT-24- Gaming and Gamification

inlife
Incubate a New Learning and Inspiration Framework for Education

S2CITY
ERDF - Smart growth 2014-2020 OP

CENCYL
Interreg 2014-2020 España- Portugal

PE4Trans
Interreg Europe - Low-carbon economy

PROJECTS

Smart & Sustainable Mobility

REMOURBAN (Phase 2)



PROJECTS

Smart & Sustainable Mobility

REMOURBAN (Phase 2)

City Information Platform - REMOURBAN



ICT measures for mobility: charging infrastructure, electric buses, parking, electric vehicles, public bicycles

ICT measures for city management: traffic sensor network, air quality, noise, weather stations

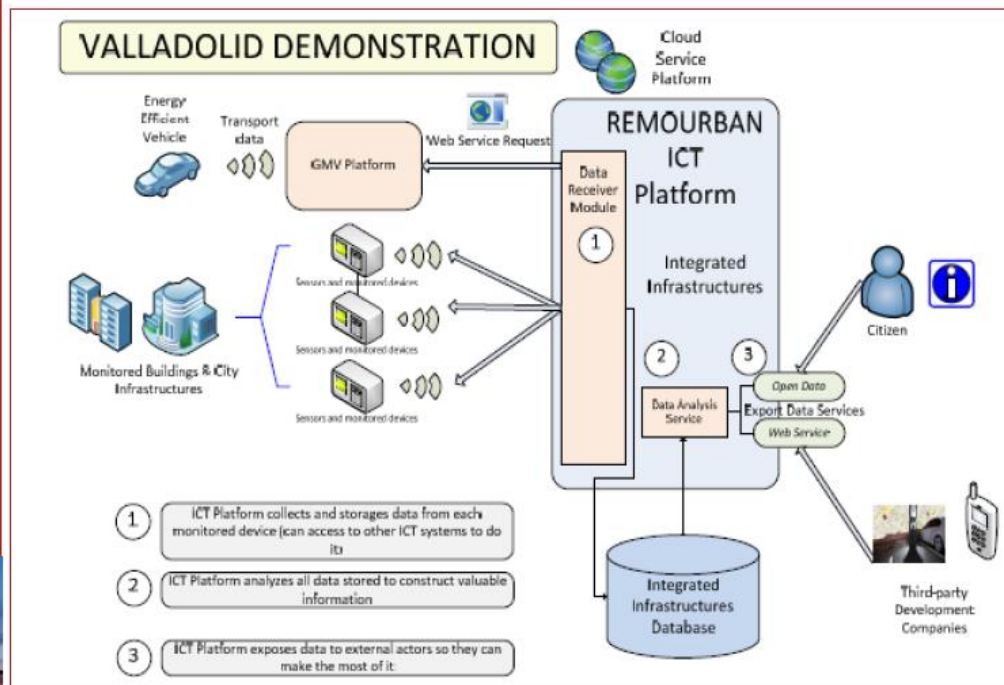

VA CIUDAD CONECTADA Y SOSTENIBLE

SEGURO SALUDABLE INTELIGENTE

Ayuntamiento de Valladolid **valladolid+D adelante**

Incentivos vehículo eléctrico

2017-2018 407.750 € **45** Nuevos vehículos eléctricos

2019 350.000 € **75** Nuevos vehículos eléctricos, de los cuales **25 motos**

RECOGIDA DE DATOS

SECTOR SERVICIOS **138** Usuarios RECARGA 2020

AUTOTAXI REPARTO URBANO DE ÚLTIMA MILLA FLOTAS EMPRESAS EXPERIENCIA DE USUARIO

BONIFICACIONES FISCALES

Exentos en tasas de LICENCIAS TAXI Y VEHÍCULOS ALQUILER ESTACIONAMIENTO

Bonificación del **75%** IVTM para VE

Bonificación del **50%** LICENCIAS ACTIVIDAD DE MANTENIMIENTO, REPARACIÓN Y RECICLAJE DE BATERÍAS
Incentivos compatibles con otros planes

2019 Flota municipal 24 Vehículos eléctricos

11 AUTOBUSES
6 RENAULT TWIZY
7 OTROS VEHÍCULOS

PLATAFORMA DE 'CAR SHARING' entre servicios municipales

DISPOSITIVOS EMBARCADOS para la extracción de datos

RECOGIDA DE DATOS

Puntos de Recarga de Promoción Municipal

7,4 kW > 0,15 cts.€/kW **RECARGA NORMAL**

4 PUNTOS **22 kW** >> 0,15 cts.€/kW **RECARGA SEMIRÁPIDA**

1 PUNTO **50 kW** >>> 0,30 cts.€/kW **RECARGA RÁPIDA**

2 PANTÓGRAFOS AUTOBUSES ELÉCTRICOS **LÍNEA 7 | AUVASA**

412 Usuarios RECARGA 2020

EXENCIÓN ORA **251** Usuarios

94 Usuarios **345** Usuarios DISTINTIVOS ESPECIALES

2017 34 PUNTOS DE RECARGA
2018 63 PUNTOS DE RECARGA
2020 138 PUNTOS DE RECARGA

PROJECTS

e-Mobility: Interoperability

Phase 3

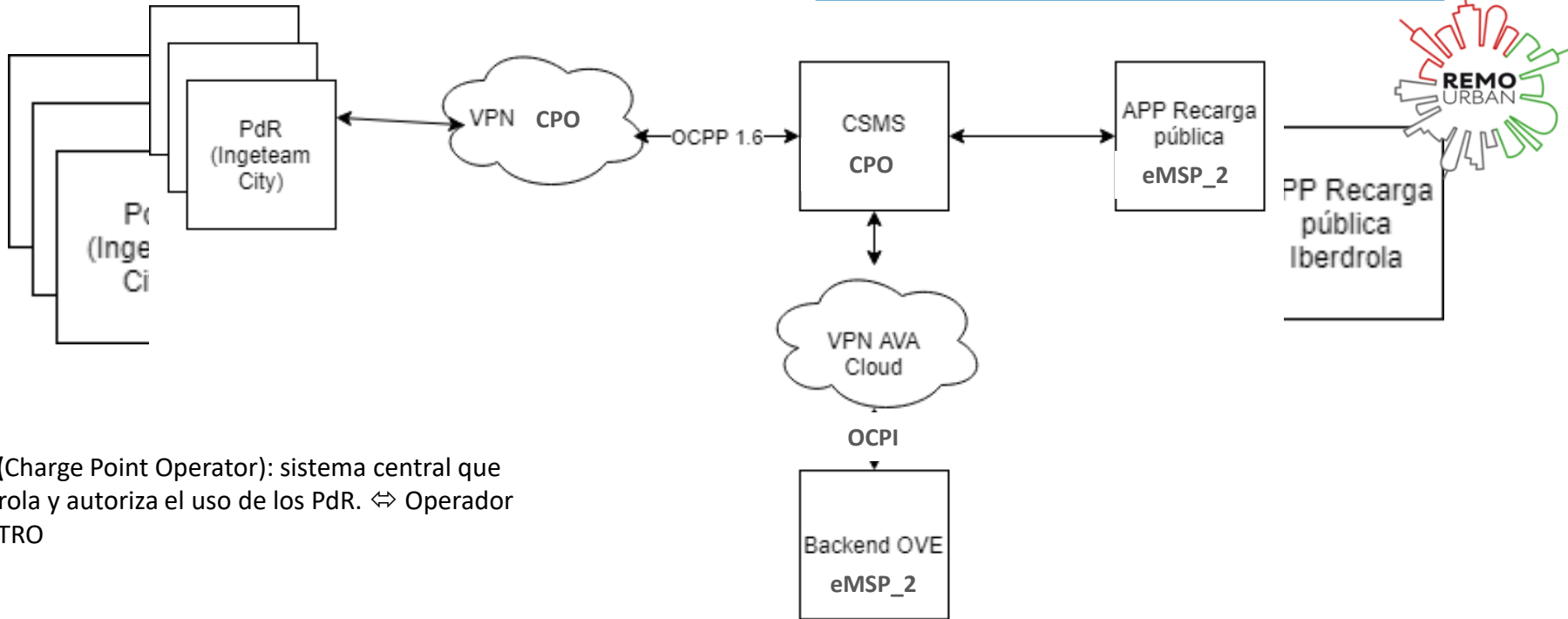

CPO(Charge Point Operator): sistema central que controla y autoriza el uso de los PdR. ⇔ Operador NEUTRO

CSMS (Charge Poi central que controla y autoriza el uso de los PdR. ⇔ Operador NEUTRO para PdR Municipales

eMSP (e-Mobility Service Provider): Permite a los usuarios de VE acceder a los servicios de recarga en PdR pública.



Ayuntamiento de **Valladolid**

PROJECTS

e-Mobility: Interoperability

Phase 3: Open Charge Point Interfase

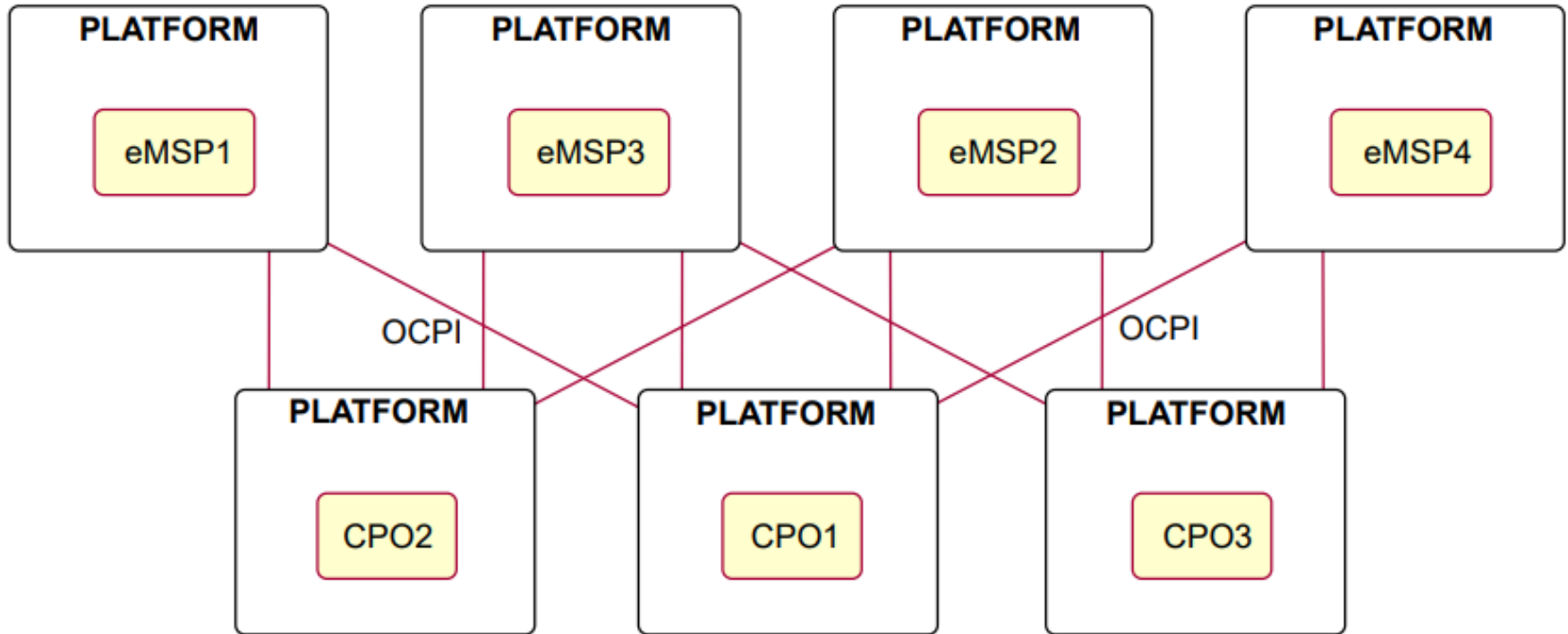

Fuente: <https://ocpi-protocol.org/>

PROJECTS

e-Mobility: Interoperability

ESTANDARIZACIÓN

IEC 63110: Management of Electric Vehicles charging and discharging infrastructures.

ISO 15118: Road vehicles -- Vehicle to grid communication interface

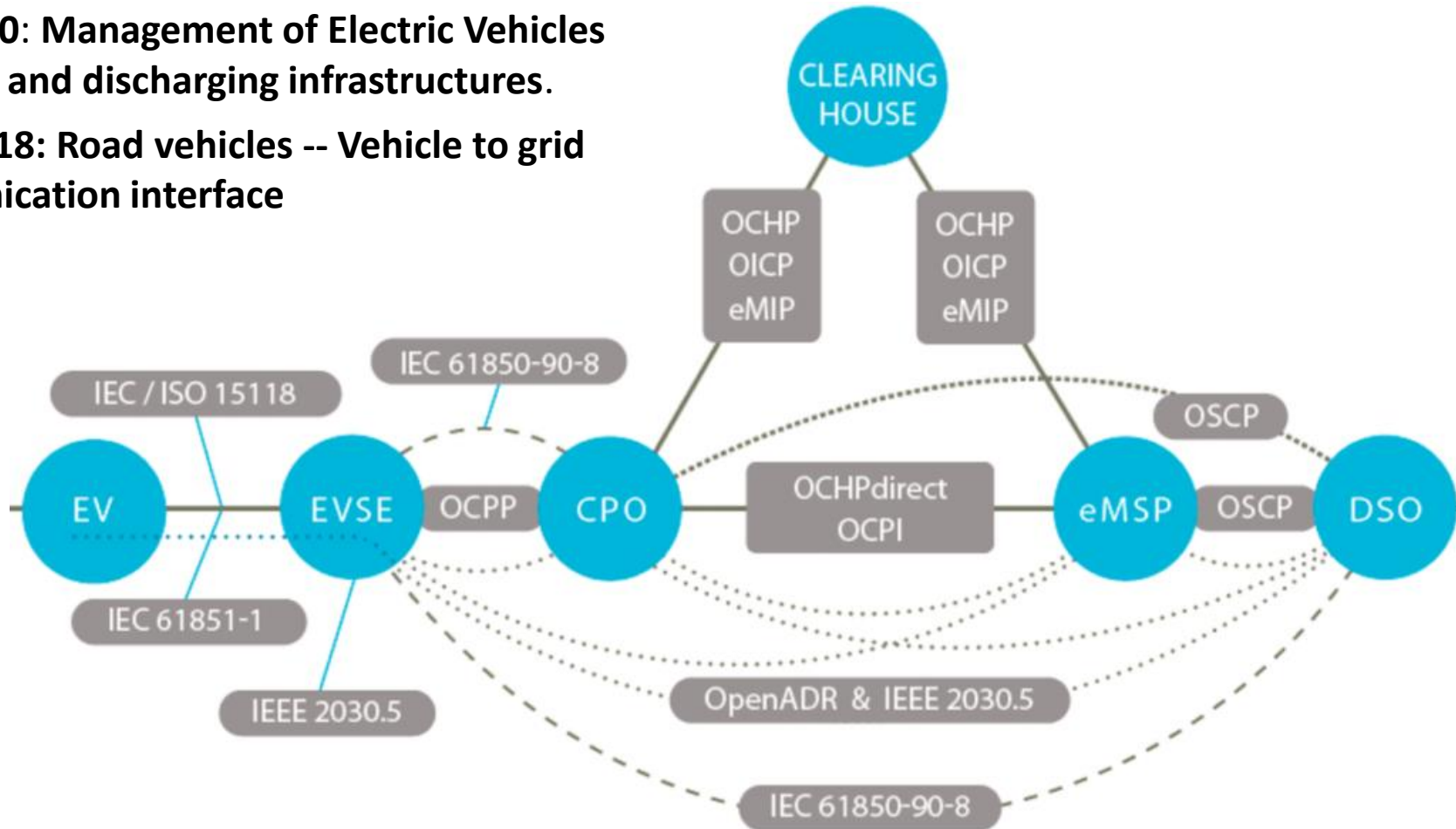

Protocols related to EV charging (Source: [ElaadNL](#))

PROJECTS

ICT - Smart Services

S2CITY

ERDF - Smart growth 2014-2020 OP

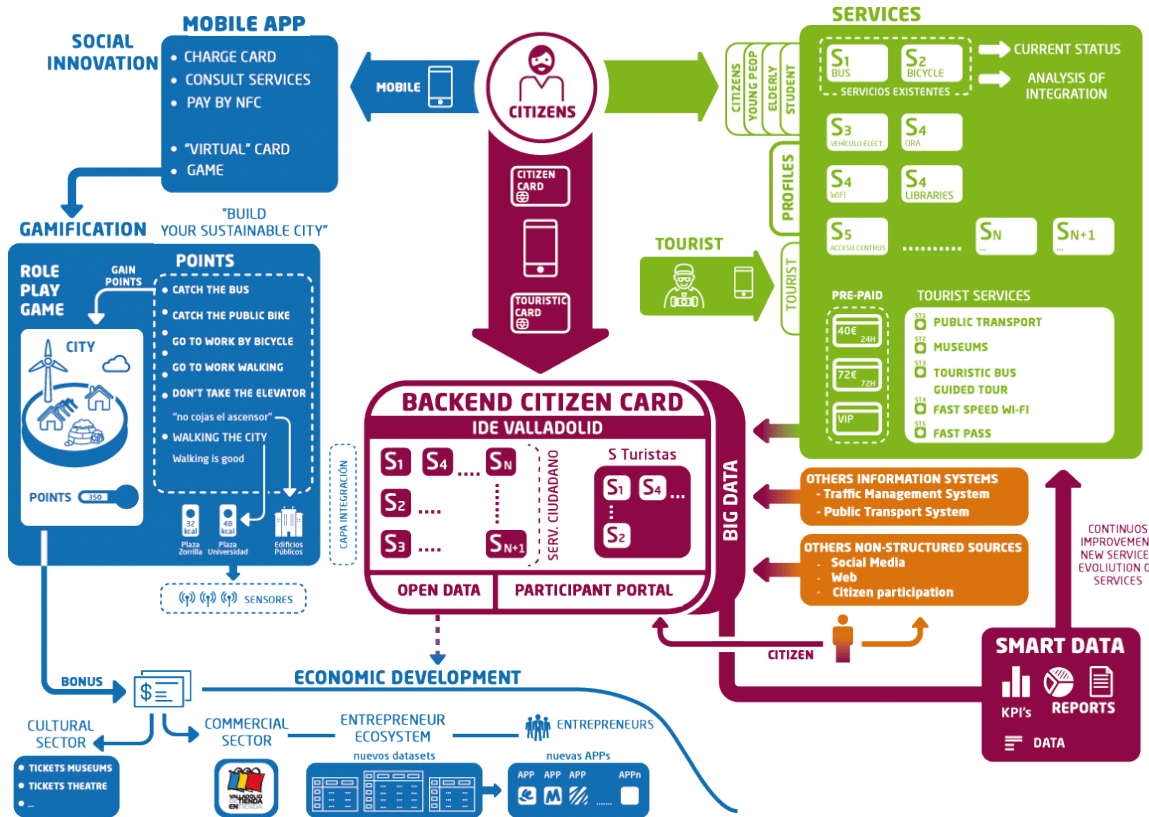

S2CITY is an innovative project in which smartphone and smart card are essential devices for enhancing the access to public services for citizens and tourists.

Within this project, the City Council gathers information of how citizens and tourists use the public services: bus public transport, public bikes, libraries, parking, among others. We use technologies of Business Intelligence, Gamification and Big data and we release the Data generated by S2CITY as Open Data

3,6M€ (70% co-financing)



KEYWORDS

#Smartphone #CitizenCard #TouristCard
 #Gamification #BusinessIntelligence #BIGData #OpenData

Gracias!

Jeronimo Hinojosa

Técnico Superior de Gestión de Proyectos Smart City

Agencia de Innovación y Desarrollo Económico

Ayuntamiento de Valladolid

[*jhinojosa@ava.es*](mailto:jhinojosa@ava.es)

W www.valladolidadelante.es

 @INNOLID

 @VLDAdeIante

 @VLDAdeIante

