

Challenges to establish a pool license for promoting standardized technology and fair competition in the market

Noriko Fukuoka
Executive Adviser
License Department
Panasonic IP Management Co., Ltd

The mechanism and structure of modern pool licenses was created to promote the MPEG 2 video standard into the market in 1993-1997

ISO/IEC Standardization

MPEG was established

Jan 1988

MPEG 1st Meeting

May 1988

MPEG2 Requirements were confirmed

Dec 1990

MPEG2 Final Draft

Jun 1994

Approved MPEG2Video

Nov 1994

If we do not solve the SEP problem, the MPEG 2 standard will end up with a paper standard.

SEP Holders

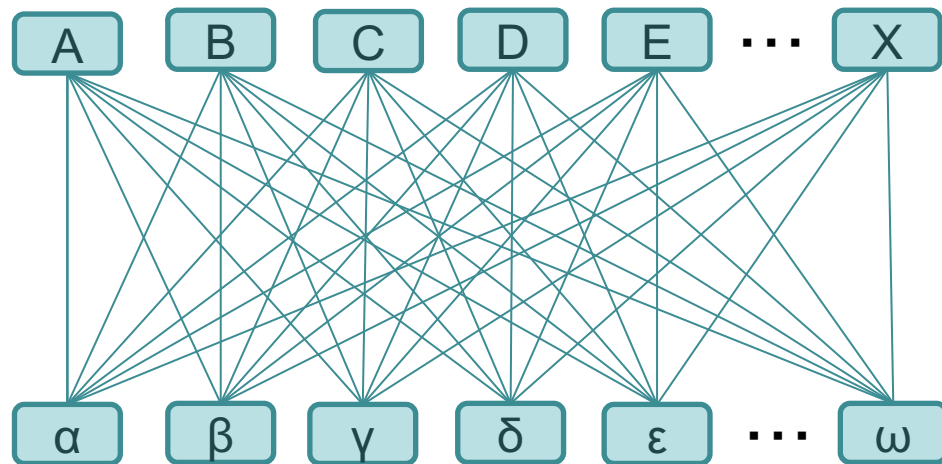

Implementers

$$\text{Royalty}(\text{total}) = R(A) + R(B) + R(C) + R(D) + R(E) + \dots + R(X)$$

It's impossible to predict or estimate final accumulate royalty amount. However, easy to predict a lot of time and money is required for license negotiations.

Wonders!

by Panasonic 2

The mechanism and structure of modern pool licenses was created to promote the MPEG 2 video standard into the market in 1993-1997

ISO/IEC Standardization

MPEG was established

Jan 1988

MPEG 1st Meeting

May 1988

MPEG2 Requirements were confirmed

Dec 1990

MPEG2 Final Draft

Jun 1994

Approved MPEG2Video

Nov 1994

July 1996

July 1997

SEP Holders

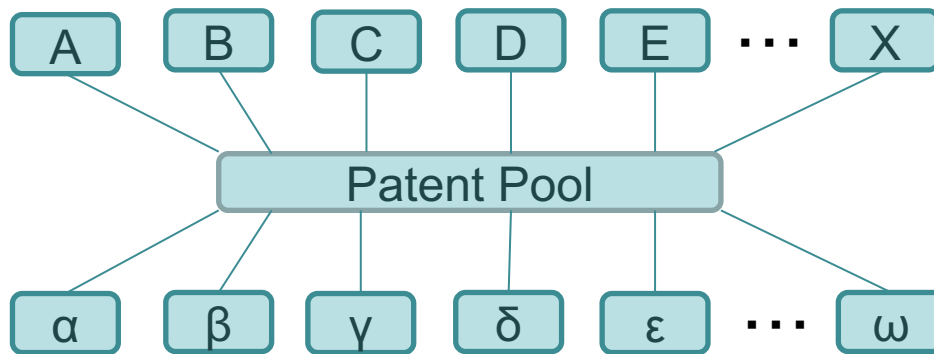

Implementers

MPEG2 IP WG was established voluntarily.

Research and evaluation of MPEG2 Video patents done by US expert.

10 SEP holders were selected

Matsushita(Panasonic), Sony, Mitsubishi, Fujitsu, Philips, Scientific Atlanta, General Instruments, Columbia University, Lucent technology, Thomson

Independent Licensing Company was established

Launch MPEG2 Pool License with 8 Licensors

Matsushita(Panasonic), Sony, Mitsubishi, Fujitsu, Philips, Scientific Atlanta, General Instruments, Columbia University

Wonders!

by Panasonic 3

MPEG2 Pool License was a Win-Win Solution for both Implementers and SEP Holders

License Start on July 1997



as of Jan 2010

- Fixed per unit royalty regardless of number of licensors and patents
- Neutral and independent patent evaluation system
- Getting more licensees invites more licensors and vice versa
- Minimize SEP risk by establishing MPEG2 FRAND benchmark
- Adequate award to SEP owners
- Establish Level Playing Field in MPEG2 market

Licensors	8 Licensors → 25 Licensors
Licensed Patents	<u>SEPs of MPEG-2 Video Standard</u> 27 patents → 772 patents
Royalty	<u>MPEG2 compliant products sold to end users</u> \$4/unit → \$2/unit \$0.04/title → \$0.0176/title
Licensees	7 Licensees → 1547 Licensees
Reciprocity	Grant-back clause : per patent royalty
Agent	MPEG LA, L.L.C (neutral & independent)
Evaluators	Independent experts in US, EU, Japan, Korea

Wonders!

by Panasonic 4

Major Pool License Programs

as of 2012	Standard	Agent	Royalty	Licensors	Licensees
Video	MPEG2	MPEG LA	\$2.0/unit	25 : Panasonic, Philips, Sony, Mitsubishi, Columbia Uni., Fujitsu, Cisco, GE...	1570
	MPEG-4 Visual	MPEG LA	\$0.25 /decoder	28 : Panasonic, Philips, Sony, NTT, GE, MS, Samsung, LGE...	695
	MPEG-4 AVC/H.264	MPEG LA	\$0.20-\$0.10 /codec	29 : Panasonic, Philips, Sony, Toshiba, Apple, MS, Samsung, LGE...	1132
	VC-1	MPEG LA	\$0.20-\$0.10 /codec	18 : Panasonic, Philips, Sony, MS...	275
Audio	AAC	Via Licensing	\$0.98-\$0.15 /unit	13 : Panasonic, Philips, Sony, Dolby, FHG, NTT, NEC...	662
Optical Disc	DVD	TDLS	4% min \$4.00/unit	9 : Panasonic, Toshiba, Hitachi, WB, Sharp, Mitsubishi, JVC, Samsung...	544
	Blu-ray Disc™ & DVD & CD	One-Blue	\$9.00/unit	15 : Panasonic, Philips, Sony, Hitachi, HP, DELL, Samsung...	36
TV	DVB-T	S.I.SV.EL.	€0.5/unit	5 : Panasonic, Philips, Orange, KPN...	235
	ATSC	MPEG LA	\$5.00/unit	8 : Panasonic, Philips, Zenith, LGE...	130
	ISDB	Uldage	\200/unit	14 : Panasonic, NHK, Sony, Mitsubishi, Toshiba, Sharp, Hitachi, Orange...	159

WORLDWIDE!

The most productive way to resolve FRAND dispute is “以和貴為,無忤為宗”
“Harmony should be valued and quarrels should be avoided”

Minimize
payment

Maximize
SEP Value



Stick on your position is not productive. Increasing cost and consuming time.

Let's find a solution to promote standardized technology and to create a future market, which is profitable for both of us.



We have enough intelligence to understand the other side and enough creativity to think of solutions together. **Wonders!**

Thank you
ご静聴有難うございました



Article 1 of the Seventeen-Article Constitution (established by Prince Shotoku in A.C 604 Japan)

Harmony should be valued and quarrels should be avoided. Everyone is apt to form a clique, and there are few people who are reasonable. Therefore some disobey their lords and fathers, and feud with their neighbors. But when superiors are in harmony and inferiors are friendly, then they discuss affairs in cooperation, everything will be reasonable spontaneously. Then there is nothing which cannot be accomplished.

Wonders!

by Panasonic 7