

International Telecommunication Union

ITU-T Technical Report

TELECOMMUNICATION
STANDARDIZATION SECTOR
OF ITU

(04 June 2020)

Focus Group on Vehicular Multimedia (FG-VM)

FGVM-01R2 **Use cases and requirements for the vehicular multimedia networks**

ITU-T

Acknowledgement

This Technical Report was prepared under the leadership of Mr Jun Li, Chair of ITU-T FG-VM (TIAA, China); Gaëlle Martin-Cocher, Chair of ITU-T FG-VM Working Group 1 (Blackberry, Canada); Kaname Tokita, Vice-chair of ITU-T FG-VM Working Group 1 (Honda, Japan); Lu Yu, Vice-chair of ITU-T FG-VM Working Group 1 (Changan Automobile Co, LTD, China); and Guo Yansong, Vice-chair of ITU-T FG-VM Working Group 1 (Great Wall Motors Co, LTD, China).

It is based on the contributions of numerous authors who participated in the Focus Group activities. Due credit is given to the following Focus Group participants representing their respective organizations:

Yajun Kou, Chen Jin, Jiali Cheng, Yufeng Xie, Guanbin Xing (Global Fusion Media Technology and Development Co., Ltd, China); Xiaofeng Yi, Yansong Guo, Srinivasagan Ayyappan (Great Wall Motor, China); Yong Wang, Jianxing Dai, Jinhui Zheng (Datang Microelectronics Technology Co., Ltd, China); Yuhua Deng (Huizhou Foryou General Electronics Co., Ltd, China); Gong Chen (Xiamen Yaxon Network, China); Pradipta Biswas (Indian Institute of Science); Hosein F. Badran (Badran Digital Consulting, Canada); Jun Xie (Desay SV Automotive Co., Ltd, China); Li Gao (Beijing Institute of Technology); Mark Every (Blackberry, Canada); Stephanie Schliffski (StratMa International Sarl); Yijie Kuang, Jin Qiu (WuHan Guo GuangTianYu Technology Co., Ltd) and Dimitri Konstantas (University of Geneva).

James Lepp (BlackBerry) served as the main editor of this technical report. Stefano Polidori (Advisor, ITU) and Mythili Menon (Project Officer, ITU) served as FG-VM Secretariat.

Summary

This document is the output of the ITU-T Focus Group on Vehicular Multimedia. It has been prepared by FG-VM/WG1 during its working sessions of 2018-2019.

This Technical Report describes the use cases and requirements for vehicular multimedia networks (VMN).

Keywords

ITS, multimedia, requirements, vehicle, use cases.

Change log

This document contains Rev.2 of the ITU-T Technical Report on "*Use Cases and Requirements for the Vehicular Multimedia Networks*". It was drafted by the editor as agreed at the ITU-T Focus Group on Vehicular Multimedia meeting held in December, Geneva, on 12-13 December 2019. Revision 2 was created in June 2020; it only adds the acknowledgment paragraph.

Editor:	James Lepp BlackBerry Canada	Tel: +1-613-595-4156 Fax: Email: jlapp@blackberry.com
----------------	------------------------------------	---

Table of Contents

		Page
1	Scope.....	1
2	References.....	1
3	Definitions	2
	3.1 Terms defined elsewhere	2
	3.2 Terms defined in this Technical Report	2
4	Abbreviations and acronyms	2
5	Conventions	4
6	Overview of the vehicular multimedia networks.....	4
	6.1 Relationship with SAE J3016 levels of driving automation	7
	6.1.1 Matching of generic multimedia use cases with driving levels.....	9
7	Connectivity.....	9
	7.1 Distinction between brought-in, built-in and hybrid connectivity	9
	7.1.1 Brought-in connectivity	9
	7.1.2 Built-in connectivity	10
	7.1.3 Hybrid connectivity	10
	7.2 Multiple network connectivity in the vehicular multimedia context.....	10
	7.2.1 Background.....	10
	7.2.2 Use-cases	11
	7.2.3 Characteristics of the VMN connectivity	12
	7.2.4 Requirements – VMS connectivity	12
	7.3 Network convergence transmission and onboard terminal processing	13
	7.3.1 Use cases	13
	7.3.2 Gap analysis.....	13
	7.3.3 Requirements – VMS converged network	14
	7.4 Networking connection among multiple terminals within the vehicle.....	14
	7.4.1 Use case A – Nomadic device connectivity	14
	7.4.2 Use case B – Screen casting	14
	7.4.3 Requirements – Display Screens and terminals connectivity.....	15
	7.4.4 Use case C – Comfort and well-being on board.....	15
	7.4.5 Use case D – On-demand functions for privately owned vehicle	16
	7.5 Continuous and consistent services across various networks and environment (from/to VMS).....	16
	7.5.1 Use case A – Continuity of service	16
	7.5.2 Use case B – Cloud based services.....	17
8	Intelligent human machine interfaces (HMI) for VMS	18
	8.1 The acoustic system in the vehicular multimedia.....	19
	8.1.1 Background.....	19
	8.1.2 Use-cases	20

8.1.3	Gap analysis.....	21
8.1.4	Requirements – Acoustic.....	21
8.2	Gesture control in vehicular multimedia system.....	22
8.3	Eye-movement control in vehicular multimedia system.....	22
8.3.1	Real time eye gaze tracking scenario	22
8.3.2	Use case – Gaze tracking.....	23
8.3.2.1	Requirements.....	23
8.3.3	Use case – Controllable camera through eyes.....	23
8.4	Data formats and storage	24
8.4.1	Use case and considerations	24
8.4.1.1	Requirements – Data format.....	24
9	Privacy considerations	24
9.1	Background.....	24
9.2	General privacy requirements.....	25
9.3	Use case – Private vehicle with one single user	26
9.3.1	Requirements.....	26
9.4	Use case – Long distance shared vehicle with multi users (shuttle all users are seated).....	26
9.4.1	Requirements.....	26
9.5	Use case – Public transportation shared vehicle with multi users (shuttle short distance trips – seated and standing users).....	27
9.5.1	Requirements.....	27
10	Content rights protection in a converged network environment	27
10.1	Background.....	27
10.2	Use cases	29
10.2.1	Use case A – VMS with flexible EMM.....	29
10.2.2	Use case B – VMS with extended EMM.....	30
10.3	Gap analysis.....	31
10.4	Requirements – Content rights protection requirements for CA.....	31
11	Copyright and rights management support for content delivery	32
11.1	Use case – Content payment and copyright protection	32
11.1.1	Requirements – Copy protection	32
11.2	Privilege and account management	32
11.2.1	Use cases	32
11.2.2	Requirements.....	34
11.3	Payment services in shared vehicle	34
11.3.1	Use case – Time shared vehicle.....	34
11.3.1.1	Proposed requirements	35
12	Security.....	35
12.1	Use Case – User data protection.....	35
12.1.1	Requirements.....	35

12.2	Use Case – VMN application security	35
12.2.1	Requirements	35
12.3	Use Case – VMS software security	36
12.3.1	Requirements	36
13	Safety	36
13.1	Use case – Driving safety: Speed control	36
14	Definition of vehicular multimedia configurations	36
14.1	Use case – Vehicular multimedia configurations	36
14.1.1	Requirements – Vehicular multimedia configurations	37
14.2	Example of VMS reference configuration	37
14.2.1	M0 configuration	38
14.2.2	M1 configuration	38
14.2.3	M2 configuration	38
14.2.4	M3 configuration	39
14.2.5	M4 configuration	40
14.2.6	M5 configuration	41
15	Vehicle domain service (VDS)	42
15.1	General	42
15.2	Vehicle domain service on vehicle multimedia service	43
15.2.2	Requirements – VDS use case in relation with VMS	45
16.	Matching of described use cases with driving levels	45
Annex A	Vehicle domain service requirements	47
A.1	Background	47
A.2	Proposed requirements	48

Technical Report ITU-T FGVM-01R2

Use cases and requirements for the vehicular multimedia networks

1 Scope

This document describes use-cases and requirements for converged network vehicular multimedia networks (VMNs), taking into account the autonomous levels defined by [SAE J3016] and used in conjunction with advanced driver assistance system (ADAS), automatic driving technologies, maps, voice commands or natural language processing.

2 References

- [ITU-T E.164] Recommendation ITU-T E.164 (2010), *The international public telecommunication numbering plan*.
- [ITU-T H.550] Recommendation ITU-T H.550 (2017), *Architecture and Functional Entities of Vehicle Gateway Platforms*.
- [ITU-T H.560] Recommendation ITU-T H.560 (2017), *Communications Interface between External Applications and a Vehicle Gateway Platform*.
- [ITU-T F.749.1] Recommendation ITU-T F.749.1 (2015), *Functional requirements for vehicle gateways*.
- [ITU-T F.749.2] Recommendation ITU-T F.749.2 (2017), *Service Requirements for Vehicle Gateway Platforms*.
- [ITU-R BS.2384] Report ITU-R BS.2384-1 (2019), *Implementation considerations for the introduction and transition to digital terrestrial sound and multimedia broadcasting*.
<https://www.itu.int/pub/R-REP-BT.2384>.
- [ITU-R BT-2052] Recommendation ITU-R BT-2052-1 (2015), *Planning criteria for terrestrial multimedia broadcasting for mobile reception using handheld receivers in VHF/UHF bands*.
<https://www.itu.int/rec/R-REC-BT.2052/en>.
- [ITU-R BT.2055-1] Recommendation ITU-R BT.2055-1(2018), *Content elements in multimedia broadcasting systems for mobile reception*.
- [ATSC] ATSC [Online]. Available: <https://www.atsc.org/wp-content/uploads/2015/03/Conditional-Access-System-for-Terrestrial-Broadcast.pdf>.
- [ChinaDRM] ChinaDRM [Online]. Available: <http://www.abp2003.cn/BZCX/BZCXDetail?PageCount=20&Page=3>.
- [CN-CAS] CN-CAS [Online]. Available: <http://www.abp2003.cn/BZCX/BZCXDetail?PageCount=20&Page=8>.
- [DoT PII-1] DoT PII [Online]. Available: https://www.its.dot.gov/factsheets/pdf/Privacy_factsheet.pdf.
- [DoT PII-2] GDPR (2018), *Reform of EU data protection rules* [Online]. Available: https://ec.europa.eu/commission/priorities/justice-and-fundamental-rights/data-protection/2018-reform-eu-data-protection-rules_en.

- [ETSI ETR 289] ETSI ETR 289 ed.1 (1996), *Digital Video Broadcasting (DVB); Support for use of scrambling and Conditional Access (CA) within digital broadcasting systems*. [Online]. Available: https://www.etsi.org/deliver/etsi_etr/200_299/289/01_60/etr_289e01p.pdf.
- [HongYan] HongYan [Online].
- [Hong Yun] Hong Yun Project [Online]. Available: <http://www.fyjs.casic.cn/n3933850/c10540840/content.html>.
- [IEEE 802.11p] 802.11bd, C-V2X (e.g., LTE-V (3GPP TS36.321), 5G PC5 (3GPP TR 38.885)).
- [IETF email] IETF email [Online]. Available: <https://tools.ietf.org/html/rfc5322#section-3.4>.
- [ISO 23239] ISO 23239-1:2018 *Road vehicles – Vehicle domain service (VDS) – Part 1: General information and use case definitions* [Online]. Available: <https://www.iso.org/standard/75045.html>.
- [OMA DRM] OMA DRM [Online]. Available: http://www.openmobilealliance.org/release/DRM/V2_2-20110419-C/.
- [OneWeb] OneWeb [Online]. Available: <https://www.fcc.gov/document/fcc-grants-oneweb-us-access-broadband-satellite-constellation>.
- [radiodns] radiodns [Online]. Available: <https://radiodns.org/>.
- [SAE J3016] SAE, Standard J3016 (2018), *Taxonomy and Definitions for Terms Related to Driving Automation Systems for On-Road Motor Vehicles* https://www.sae.org/standards/content/j3016_201806/.
- [Starlink] Starlink[Online]. Available: <https://www.fcc.gov/document/fcc-authorizes-spacex-provide-broadband-satellite-services>.

3 Definitions

3.1 Terms defined elsewhere

None.

3.2 Terms defined in this Technical Report

This Technical Report defines the following terms:

3.2.1 vehicular multimedia networks (VMN): The VMN consists of the vehicular multimedia service platform (VMSP), a variety of broadcast and communication networks and of the vehicle multimedia system (VMS) in the vehicle.

3.2.2 vehicle multimedia system (VMS): The VMS consists of vehicle multimedia system inputs (VM I/P), vehicle multimedia unit (VMU) and vehicle multimedia system outputs (VM O/P). It is also called an IVI.

3.2.3 vehicular multimedia networks services (VMNS): The VMNS are the services provided by service providers via the VMN.

3.2.4 VMN application: The VMN application uses the underlying VMS capabilities to consume and present a VMNS to end-user(s) in the vehicle.

4 Abbreviations and acronyms

This Technical Report uses the following abbreviations and acronyms:

ADAS	Advanced Driver Assistance System
AEC	Acoustic Echo Cancelation
AM	Amplitude Modulation
APP	Application
AR	Augmented Reality
BCM	Body Control Module
BT	Bluetooth
CA	Conditional Access
CW	Control Word
CDR	China Digital Radio
DAB	Digital Audio Broadcast
DRM	Digital Rights Management
DTMB	Digital Terrestrial Multimedia Broadcast
DVB	Digital Video Broadcasting
DVR	Digital Video Recorder
ECM	Entitlement Control Message
ECU	Electronic Control Unit
EMM	Entitlement Management Message
FG	Focus Group
FM	Frequency Modulation
GDPR	General Data Privacy Regulation
GNSS	Global Navigation Satellite System
HD	High Definition
HMI	Human Machine Interface
HUD	Heads Up Display
HUT	Infotainment Head Unit
ID	Identification
IVI	In Vehicle Infotainment
KWS	Keyword Spotter
LCD	Liquid Crystal Display
LEO	Low Earth Orbit (Satellite)
MMS	Multimedia Messaging Service
OLED	Organic Light Emitting Diode
PDK	Personal distribution key
PII	Personally Identifiable Information
PK	Personalisation Key
PK	Product Key

QoS	Quality of Service
RDS	Radio Data System
RF	Radio Frequency
SMS	Short Message Service
T-Box	Telematics System
TM-Box	Telematics Multimedia System
TS	Transport Stream
USB	Universal Serial Bus
VDS	Vehicle Domain Service
VDDM	Vehicle Domain Dynamic Map
VG	Vehicle Gateway
VGP	Vehicle Gateway Platform
VM I/P	Vehicle Multimedia System Inputs
VM O/P	Vehicle Multimedia System Outputs
VMN	Vehicular Multimedia Networks
VMNS	Vehicular Multimedia Networks Services
VMSP	Vehicular Multimedia Service Platform
VMS	Vehicle Multimedia System
VMU	Vehicle Multimedia Unit
VR	Virtual Reality
WLAN	Wireless Local Area Network
WG	Working Group
ZIC	Zone Interference Cancellation

5 Conventions

None.

6 Overview of the vehicular multimedia networks

As shown in Figure 1, vehicle multimedia networks (VMN) consist of the vehicular multimedia service platform (VMSP) in the cloud, a variety of broadcast and communication networks, and the vehicle multimedia system (VMS) in the vehicle.

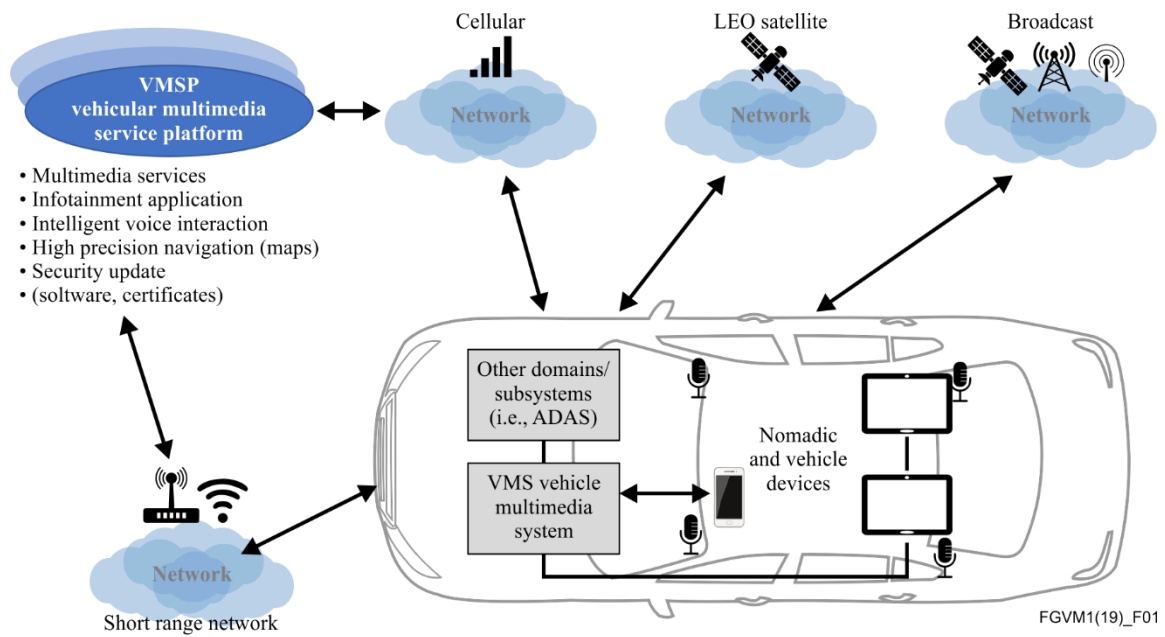

Figure 1 – Vehicle multimedia networks

A reference model of the VMS is shown in Figure 2, where the overall boundary of the VMS is given. The VMS consists of vehicle multimedia system inputs (VM I/P), vehicle multimedia unit (VMU) and vehicle multimedia system outputs (VM O/P).

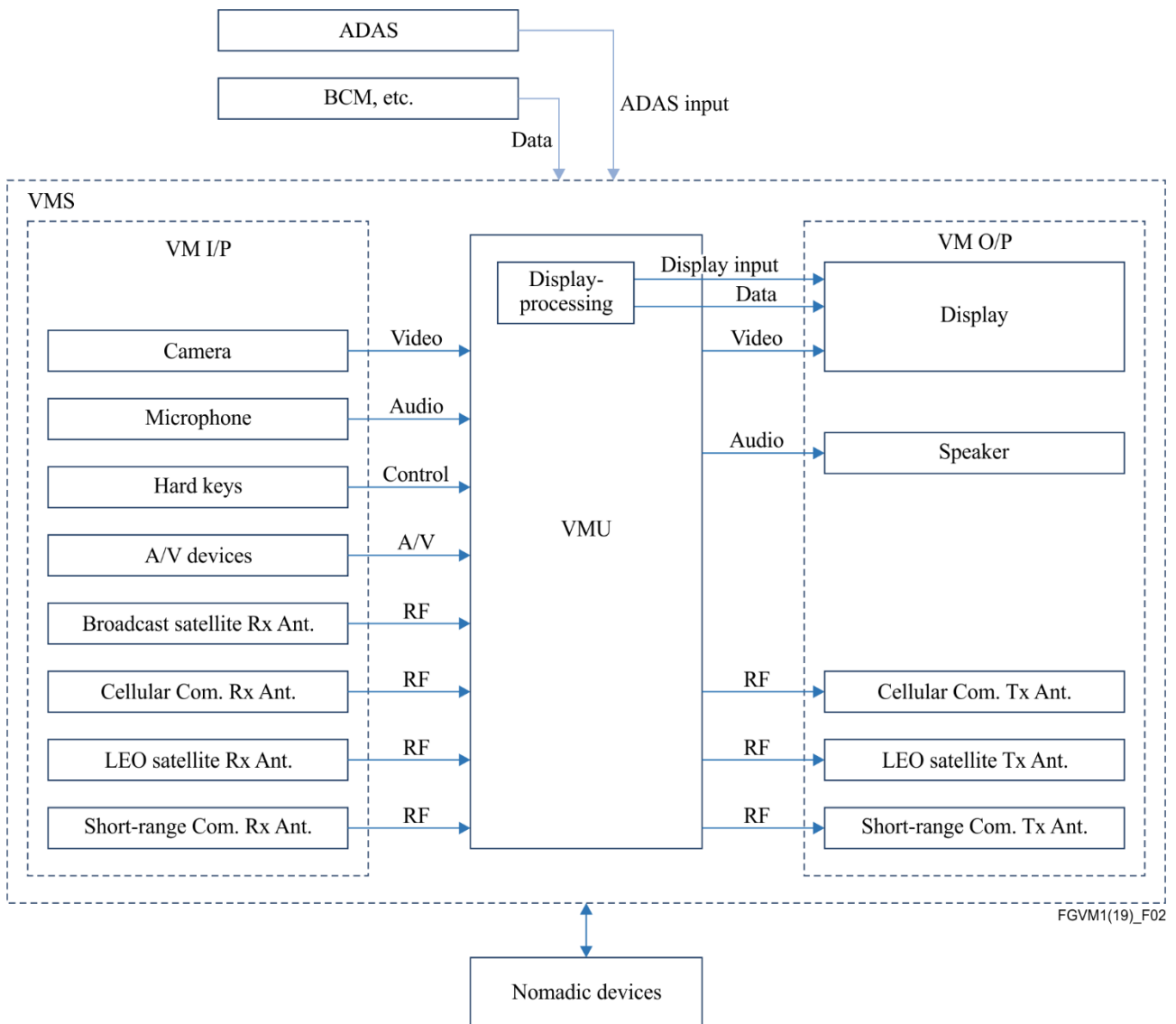

Figure 2 – A reference model for data input/output of the vehicle multimedia system

System inputs may include audio and video signals from camera, microphone and audio/video devices such as USB devices, Bluetooth devices, SD-Cards, CD/DVD/Blu-ray and Aux-In, control signals from hard keys, and RF signals from reception antennas. Note that the connectivity functions and the related recommendations for intelligent transport systems have been discussed in ITU-T SG16 Question 27 (Q.27). These functions and recommendations, as defined in Q.27 may be reused for the connectivity in vehicle multimedia systems.

VMU is a central processing unit that processes the received input and output audio via the speakers, video via displays, etc.

Antenna systems for cellular communications, low earth orbit (LEO) satellites and short-range communications are used for reception and transmission.

VMU is not a single physical unit. It may consist of multiple electronic control units (ECUs). Options include either (a) infotainment head unit (HUT) and telematics system (T-Box), (b) telematics multimedia system (TM-Box), and (c) any other integrated solutions customized by automotive manufacturers such as just a HUT.

Note that a T-box alone as defined in Q.27 could not satisfy the requirements of a vehicle multimedia system, which include but is not limited to the connectivity requirements and the multimedia processing requirements. Nevertheless, the connectivity capability of the T-box could be used to

partially satisfy the connectivity requirements of the vehicle multimedia system. In such a case, option (a) as described above is a sound solution for the vehicle multimedia system, where HUT together with T-Box fulfils all the requirements of a vehicle multimedia system.

A VMN application is either a pre-installed or a downloaded application on the VMS available in the vehicle. The VMS application makes use of the VMS capabilities to present the VMNS to end-user(s) in the vehicle. The VMN application is configured to retrieve the VMS capabilities and connect to the VMNS. There may be multiple VMN applications in a vehicle and at different seat/screen positions.

Other system inputs such as those from the advanced driver assistance system (ADAS), body control module (BCM), etc., are processed by the VMU mainly for display. Nevertheless, for autonomous driving capable vehicles, the interaction between autonomous driving domains/function blocks or ADAS and the VMS need to be addressed in detail in the future. For example, the system could limit some VMS functions (e.g., no broadcasting or no conference calls) based on ADAS domain input that the vehicle is operating at level 3 or below, while it would be allowed for level 4/5 particularly for the driver's position.

Nomadic devices such as mobile phones and handheld wireless devices are another group of devices whose data are processed by VMU for audio, video and control, but they are not part of the VMS.

With the development of ADAS and autonomous driving, the multimedia trend for a vehicular multimedia system includes:

- Multi-screens;
- Multi-instruments: e.g., glass to replace the screen of the in-vehicle infotainment;
- Multi-screen interaction;
- Multi-purpose: used for entertainment, official, social, gaming, etc;
- Holographic projection will be popular in the future.

6.1 Relationship with SAE J3016 levels of driving automation

For the purpose of a common understanding the [SAE J3016] "Levels of Driving Automation" responsibilities of the driver per driving level are explained in this clause. See also Figure 3.

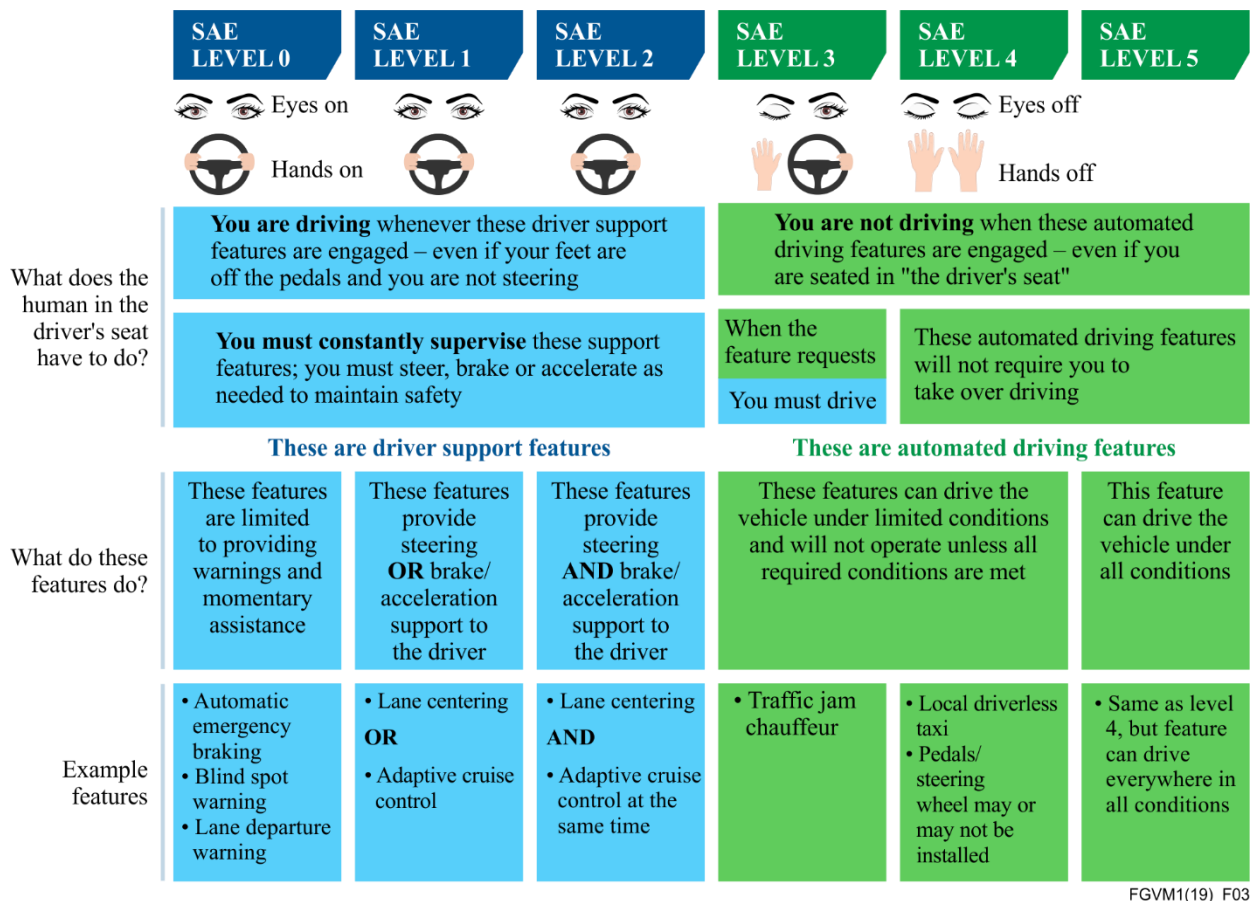

FGVM1(19)_F03

Figure 3 – SAE J3016 definition of driving levels

(Sources: SAE International Release update (11.12.2018), illustration Mike Lemanski (TRW, ZF) (16.04.2017))

In levels 0, 1 and 2 the driver has to keep the eyes on the road and the hands on the steering wheel. The driver is fully in charge of the vehicle.

In level 2 driving, safety features will support the driver in his driving tasks and will make driving safer by intervening with corrective actions if necessary, e.g., emergency braking or lane keeping. However, at no time the vehicle will drive autonomously.

Level 3 driving is a first level of partly automated driving. Due to available driving features and legal constraints those automated driving features are allowed for use in limited or geofenced areas, such as on highways, or under a certain speed, e.g., in traffic jams with a speed up to 40 km/h (when speed gets faster driver is requested to take over control again). However, due to legislation the driver is still fully in charge for the vehicle even when driving in autonomous mode. This means that even if the driver take the hands off the steering wheel while driving autonomously, the driver still needs to keep the eyes on the road and be able to take over control from the vehicle at any time and within a very short timeframe in case of unexpected situations.

In driving levels 4 and 5 vehicles no longer need steering wheels or pedals. Vehicles drive autonomously. All persons in the vehicle become passengers. The vehicle has no driver.

Level 5 is the highest level of automation allowing vehicles to drive autonomously in any condition and every geographic area. The vehicle can drive fully autonomously without having any persons on board.

Driving levels mainly apply to the driver and make a difference for him being in charge of the vehicle or not. However, all other persons on board of a vehicle no matter if on the front passenger seat or on rear seats are passengers no matter which driving level applies.

6.1.1 Matching of generic multimedia use cases with driving levels

The following table matches generic use cases and services with the driving levels. All activities that are mentioned in the table should be considered for a driving vehicle. When the vehicle parks or stands still, all services are available for the driver as well as for the passengers. Excluded in this case is a standing vehicle at traffic lights or other traffic signs as in this case the vehicle and the driver are still considered as active traffic participants similar to a driving car.

Within the driving levels a distinction on what drivers (D) and passengers (P) are allowed to do in the framework of these use cases and services is taken into consideration.

Use Case	SAE LEVEL 0		SAE LEVEL 1		SAE LEVEL 2		SAE LEVEL 3		SAE LEVEL 4		SAE LEVEL 5	
	D	P	D	P	D	P	D	P	D	P	D	P
Listen to audio services	✓	✓	✓	✓	✓	✓	✓	✓	✓	✓	✓	✓
Use video, TV and gaming services		✓		✓		✓		✓	✓	✓	✓	✓
Use mobile devices		✓		✓		✓	(✓)	✓	✓	✓	✓	✓
Use mobile devices through VMS	✓	✓	✓	✓	✓	✓	✓	✓	✓	✓	✓	✓
Phone conferencing (handsfree)	✓	✓	✓	✓	✓	✓	✓	✓	✓	✓	✓	✓
Video conferencing		✓		✓		✓		✓	✓	✓	✓	✓
Reading in vehicle (books, mails, news, etc.)		✓		✓		✓		✓	✓	✓	✓	✓
Getting read content (text-to-speech)	✓	✓	✓	✓	✓	✓	✓	✓	✓	✓	✓	✓
Working in vehicle (office applications)		✓		✓		✓		✓	✓	✓	✓	✓

FGVM1(19)_F04

- ✓ = Allowed
- (✓) = Partly allowed (in autonomous driving mode)

Figure 4 – Matching of generic multimedia use cases with SAE driving levels

The above table follows the guidelines of current legal framework in place in some jurisdiction. (e.g., US and EU. Note: Some other jurisdictions may use similar or different classifications than those in [SAE J3016]). However, from an ergonomic point of view phoning or getting read content while driving through text-to-speech can lead to a cognitive overload for the driver and can lead to critical driving situations. Therefore, for driving levels 0 to 3, it is suggested to integrate driver monitoring into the vehicle in order to measure the cognitive load of the driver and to adapt access and content to driving situations and distraction level.

In addition, driver monitoring in driving level 3 facilitates tracking if the driver has taken back control when requested or if alternative actions need to be taken in order to bring the vehicle to a safe stop.

7 Connectivity

7.1 Distinction between brought-in, built-in and hybrid connectivity

In-vehicle connectivity can be distinguished in three connectivity cases, that is, brought-in, built-in and hybrid connectivity.

7.1.1 Brought-in connectivity

The multi-media system of the vehicle is neither connected to the internet nor to other connected services and applications (maybe with the exception of radio FM). Due to legal requirements in certain jurisdictions the only VMS connectivity that is built-in might be for emergency calls.

However, the limited bandwidth for emergency calls might not allow access or stream to any other connected services and APPs.

The user can connect the VMS in this case through his mobile device that he brings into the vehicle. The mobile device will connect with the car through Bluetooth, USB or other connections.

Content of the mobile device like APPs and mobile services will be displayed on the VMS through MirrorLink, Apple CarPlay or Android Auto, for example.

All connected APPs and services are accessible through the VMS.

7.1.2 Built-in connectivity

The vehicle is fully connected to the Internet, APPs and connected services through its built-in connectivity.

All APPs and services can be accessed through the VMS.

7.1.3 Hybrid connectivity

Hybrid connectivity is a mixture of brought-in and built-in connectivity.

The vehicle has its own built-in connectivity. However, the user can bring-in additional connected services and APPs through its mobile devices. As for the brought-in connectivity, the mobile device connects to the vehicle through Bluetooth, USB or other types of connection and its services and APPs can be displayed on the VMS through MirrorLink, Apple CarPlay, or Android Auto. The user accesses all vehicle connected services and APPs through the VMS

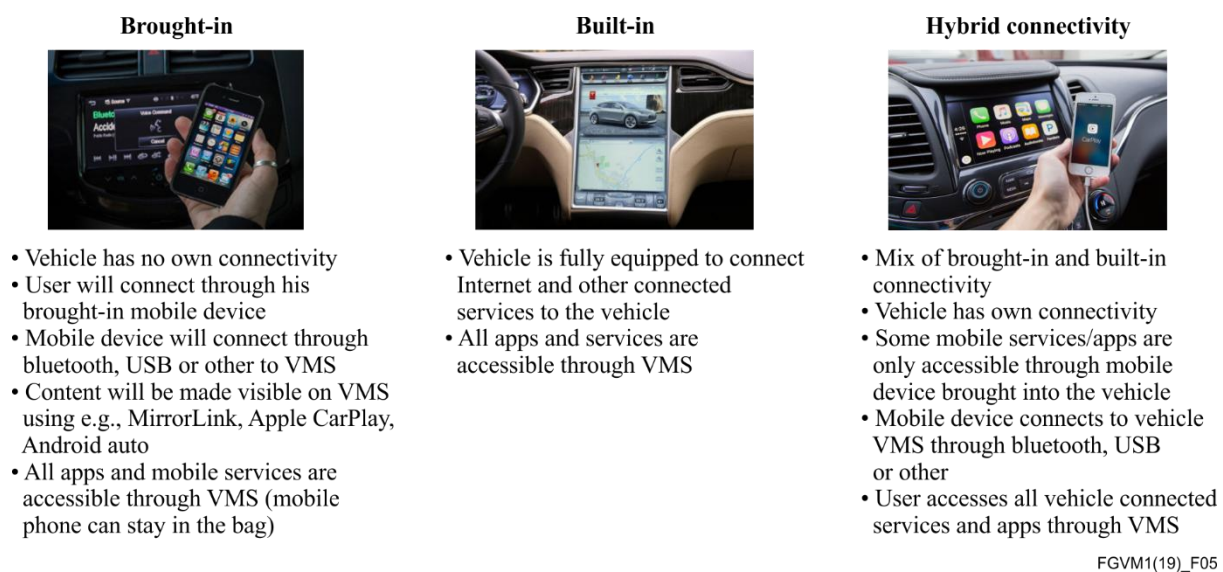

Figure 5 – Vehicle connectivity (with credit to Tesla, GM)

Ideally, in all the above cases, access to services, APPs and content displayed are adapted to driving situations and to the location of users within the vehicle in order to minimize distraction for the driver.

7.2 Multiple network connectivity in the vehicular multimedia context

7.2.1 Background

Most vehicular audio/video entertainment systems have at least FM/AM radio functions, while digital radio and sound broadcasting receivers are becoming more common [ITU-R BS.2384], due particularly to the European Union mandating DAB+ receiver in all new cars. With the improvements

of networking technologies, online radio and audio/video entertainment services in intelligent connected vehicles are becoming more and more popular.

On one hand, traditional one-way broadcasting systems, i.e., FM/AM, terrestrial digital broadcasting, and satellite broadcasting, only support one-way transmission mode. Hence, interactive and personalized services can hardly be achieved by such broadcasting networks.

On the other hand, mobile networks support two-way transmission modes. By using mobile network, online multimedia entertainment services can be provided to users to satisfy interactive and personalized demands. However, there are three drawbacks:

- 1) In certain situations, the cost of mobile Internet is an important factor impeding the wide deployment of VMNS in intelligent connected vehicles.
- 2) The wireless coverage of mobile networks is not fully guaranteed. For example, the signal strength can be limited or non-existent in certain locations, and, therefore, users may experience a poor connection and experience when at those locations.
- 3) The mobile network can be congested, which impacts the smoothness of online audio/video playback and degrades the user experience.

7.2.1.1 Converged network empowers migration to more advanced services

Network convergence transmission takes advantage of the complementary strengths of broadcasting and mobile Internet infrastructures to overcome their limitations. Based on the converged network transmission channels, the rich media contents and information can be delivered to all kinds of terminals in an efficient and timely manner, i.e., intelligent connected vehicles, personal mobile terminals, etc.

The VMS retrieves rich media contents from a VMSP through various networks and serves as a local infotainment centre. The VMS can not only play the contents locally on the built-in vehicle screens and speakers but can also share the contents with passengers' personal devices (for example, smartphones and tablets, using in-vehicle Wi-Fi connections).

The VMS seamlessly integrates the services received from various broadcasting networks and bi-directional networks. In particular, when the VMS is in-coverage of multiple broadcasting networks, it could intelligently select one of the broadcasting networks to receive the service. Such choice can be made based on various factors, such as network signal strength, terminal processing power, cost, etc.

7.2.2 Use-cases

7.2.2.1 Use case A – In-city commuting/native life service as driving purpose

1. Satisfy the needs of personalized and two-way interactions.
2. Provide undegraded quality of service (QoS) for audio/video streaming services.

The coverage of cellular mobile network in densely-populated city areas is fairly good. However, as more and more users are trying to access the cellular mobile network, the connection speed for each user becomes lower and lower. In such a case, mobile Internet by itself could not satisfy the user experience.

7.2.2.2 Use case B – Out-city driving

Traveling for long distances away from cities using family cars or SUVs during weekends or holidays becomes a common trend. In some regions, large population lives outside of the cities and using a vehicle is a necessity. In environments such as mountain valleys, forests or deserts, the mobile network coverage could be much poorer than in cities, which in turn cause the degradation of multimedia services.

7.2.3 Characteristics of the VMN connectivity

The VMN could have the following characteristics:

- 1) Be available on a connected vehicle (or/and autonomous vehicle).
- 2) Includes a connectivity layer allowing services to seamlessly use multiple bearers and protocols (satellite, cellular, short range / broadcast, streaming, download). That connectivity layer is usable by various sub-systems and services such as infotainment, maps or ADAS.
- 3) The VMS may connect to one or more communication networks, in particular:
 - 3G/4G/5G cellular networks.
 - Low Earth Orbit (LEO) bi-directional communication networks (e.g., [Starlink], [Onweb], [HongYan], [Hong Yun]).
 - Satellites (e.g., L Band Broadcast) with both broadcast and bi-directional communications.
 - Short range networks such as DSRC (e.g., IEEE 802.11p; 802.11bd), C-V2X (e.g., LTE-V (3GPP TS36.321), 5G PC5 (3GPP TR 38.885)).
 - Terrestrial broadcast networks (e.g., FM, DAB, HD radio, CDR, DTMB, DVB-T2 and upcoming FeMBMS).

Further, the following scenarios should be envisaged for VMN:

- The vehicle drives away from the coverage area of the wireless local area network (WLAN), but access to services continue to be available via cellular network or satellite network.
- The vehicle drives away from the coverage area of the cellular network, but access to services continue to be available via satellite communication.
- The vehicle drives away from the coverage area of the satellite network, but access to services continue to be available via cellular communication (e.g., entering an underground parking).
- The vehicle drives away from the coverage area of the mobile network in a region where satellite broadcasting systems are not deployed, but access to service continue to be available via terrestrial broadcast communication.
- The VMS may prefer that large downloads such as map updates and security updates be performed only on higher bandwidth network such as WLAN.
- Network connectivity may be billed to the driver, or it may be billed to the vehicle manufacturer. In either case, the driver/manufacturer may want to limit types of data transmitted over higher-cost networks. For example, diagnostic data can be uploaded at a later time when WLAN is available, whereas safety related information may be downloaded via any means available.
- The VMS may receive indicators over a broadcast network (e.g., radio data system (RDS) program identifier) and connect to a server over a cellular or short-range data connection to download metadata about the program [radiodns].
- The VMS may transmit/receive multimedia information such as image/video, voice and broadcast messages (such as emergency messages received and retransmitted to nearby vehicles) through wireless short-range communication networks (e.g., DSRC, C-V2X).

7.2.4 Requirements – VMS connectivity

CR1: The VMS should be designed to allow access via multiple communication networks.

CR2: The VMS may connect via multiple communication networks simultaneously.

CR3: The VMS may provide seamless handoffs between communication networks.

CR4: The VMS shall be inclusive of both bi-directional and broadcast communication networks.

CR5: The VMS shall allow the user to configure or limit types of data transmission over various communication networks.

7.3 Network convergence transmission and onboard terminal processing

The network architecture of convergence transmission, as shown in Figure 6, illustrates how the network convergence greatly improves system efficiency and user experience.

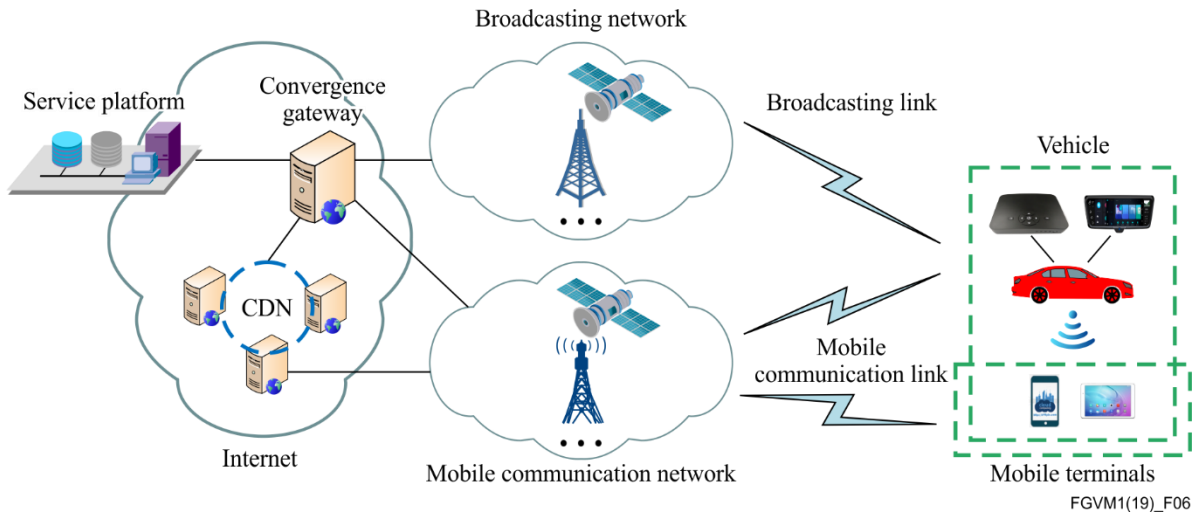

Figure 6 – The network architecture of convergence transmission

7.3.1 Use cases

Scenario 1: Vehicle A commutes in metropolitan areas with satellite broadcasting signal being intermittently blocked by high-rise buildings; vehicle B takes a weekend excursion to remote areas where 4G/5G cellular coverage is limited; vehicle C is on a long road trip across country during which favorite channels from home city are played throughout the whole trip. In either of the above cases, as long as one bearer of the converged networks has signal coverage, the services available are uninterrupted while the overall data charges are kept at minimum;

Scenario 2: Users enjoy rich media content and various services, such as live/on-demand audios and videos, pushed data, on-the-go Internet, emergency alert, global navigation satellite system (GNSS) etc., on one unified in-vehicle infotainment platform over converged networks, without having to care about the actual bearer that carries the service;

Scenario 3: The driver in a vehicle equipped with vehicular multimedia system can enjoy high-quality audio, videos and other value-added services through in-vehicle screen and speakers;

Scenario 4: Each passenger inside a vehicle equipped with VM system can enjoy their own choice of high-quality audio, video, and other value-added services on their personal smartphones or tablets through Wi-Fi access;

Scenario 5: Users who have downloaded the APP on their mobile phones/pads can continue enjoying the same program at the same quality of service using their own internet connections, when out of the vehicle Wi-Fi coverage.

7.3.2 Gap analysis

Various media services, i.e., live/on-demand audio/video service, pushed data service, on-the-go Internet service, shall be supported by the VMN and the vehicle VMS over a variety of underlying broadcast and communication networks. In order to guarantee the QoS of these services and improve the network efficiency, carefully designed transmission protocols and reception methods shall be pursued. Firstly, the transmission protocols and reception methods shall support various underlying physical-layer transmission standards, i.e., various wireless broadcast standards and wireless access

standards, so that the QoS of these media services can be guaranteed while the vehicle is roaming across different networks. Secondly, service providers may use different application layer protocols to support similar media services, i.e., either MPEG-DASH or HLS can be used to support streaming services. Therefore, the transmission protocols and reception methods shall be transparent to the upper layer protocols so that the vehicle multimedia network can be used by various service providers to run their own services. Thirdly, the transmission protocols and reception method shall be able to take full advantage of the characteristics of various wireless networks to improve the QoS of these media services, or to optimize the overall network efficiency.

At present, ITU-T SG16/Q27 has achieved important progress in the standardization of vehicle gateway (VG) and vehicle gateway platform (VGP). In the related Recommendations [ITU-T F.749.1] and [ITU-T H.560], functional requirements for VGs, service requirements for VGPs, architecture and functional entities of VGPs, and communications interface between external applications and VGPs are well defined with a focus on intelligent transportation services. However, none of these Recommendations provides transmission protocols or reception methods that can fulfill the vehicle media service requirements of clause 7.3.

- 1) Recommendation [ITU-T F.749.1], Functional Requirements for Vehicle Gateways.
- 2) Recommendation [ITU-T F.749.2], Service Requirements for Vehicle Gateway Platforms.
- 3) Recommendation [ITU-T H.550], Architecture and Functional Entities of Vehicle Gateway Platforms.
- 4) Recommendation [ITU-T H.560], Communications Interface between External Applications and a Vehicle Gateway Platform [ITU-T H.560].

7.3.3 Requirements – VMS converged network

The requirements on network convergence transmission and onboard terminal processing are listed as follows:

R1: Convergence network transmission and reception function of the VMS shall be agnostic to the underlying physical layer transmission standards and be transparent to the upper layer applications.

R2: The VMS should take full advantage of different network characteristics to ensure uninterrupted and seamless services (e.g., to keep the overall network costs minimum).

R3: The increase in the end-to-end system converged network transmission delays due to the VMS should be minimized.

R4: The increase in the overall system start-up and channel switching time due to the convergence network transmission and reception function of the VMS shall be minimized.

R5: The VMS shall require none or minimum modifications to the existing broadcasting and mobile communication infrastructures and shall be compatible with major media streaming and broadcasting protocols.

7.4 Networking connection among multiple terminals within the vehicle

7.4.1 Use case A – Nomadic device connectivity

The VMS provides in-vehicle media content distribution over a local wireless network (e.g., Wi-Fi, Bluetooth, etc.) Various types of terminal (such as various types of IVI screens, mobile phones, tablets, etc.) can connect to the vehicular multimedia system and receive content adapted to the characteristics of the different terminals.

7.4.2 Use case B – Screen casting

Support the interactive connection between the VMS and a user's mobile device. Mobile devices use a variety of existing screen casting systems, a non-exhaustive list includes technologies such as Wi-Fi

Alliance Miracast, CCC MirrorLink, Huawei Welink, Apple CarPlay, Baidu CarLife, Android Auto, etc.

7.4.3 Requirements – Display Screens and terminals connectivity

R1: The VMS should be able to connect to various terminals (such as different types of IVI screens, mobiles, tablets, etc.) based on their capabilities.

R2: The VMS should support the interactive connection with mobile devices.

R3: Upon detection of change of the VMS user, the VMS should wipe personal data transferred through the mobile device connected to the VMS in order to respect privacy of personal data.

7.4.4 Use case C – Comfort and well-being on board

The emotional and physical conditions of driver and passengers are measured either through smart watches connected with the VMS, through scanning of facial expressions and postures with cameras or other sensors on board (e.g., sensors integrated in steering wheel or seats) that are connected to the VMS. In order to stimulate the comfort and well-being of all passengers on board and to ensure the non-drowsiness and attentiveness of the driver, the senses of persons on board are stimulated through display content, ambient light, sound, scents, as well as air distribution and flow.

In case of critical situations, such as drowsiness or distraction of the driver, VMS displays alert messages, gives audible alerts or shuts down displays in case the driver is looking away from the road for a considerable long period of time.

The information collected for each passenger is integrated in each personal profile, possibly along with other environmental information (localization, number of persons aboard, air condition, temperature, vehicle telemetry etc.).

Over time, an individual evolution measured per passenger as well as an individual profile for well-being will be created with the help of artificial intelligence running in the background of the VMS and be deposited in the cloud.

The information collected by the vehicle VMS regarding the emotional and physical status of the users, can be made available to other well-being and health related value-added services to which the user has subscribed. These services can provide information on user well-being and health needs to the vehicle VMS.

7.4.4.1 Proposed requirements

R1: VMS should have or should be connected to sensors sensing the cognitive load of the driver, and the emotional and physical conditions of all vehicle users.

R2: VMS should have or be connected to all features that can change the ambience in the vehicle such as a library of music and messages, lighting, perfume deodorizer, etc.

R3: VMS should have integrated algorithms that react to and initiate actions instantaneously including outside of network coverage.

R4: VMS should be able to connect to external well-being and health services and transmit information collected regarding each user.

R5: VMS must have storage space to save each user profile data and to send them to the cloud when network coverage becomes available.

R6: Upon detection of change of the VMS user, the VMS should wipe personal data in order to respect privacy of the user.

R7: Each individual user should have the possibility to shut down or unsubscribe the function at any time temporarily or irrevocably.

7.4.5 Use case D – On-demand functions for privately owned vehicle

Through vehicle APPs available on smart devices and on the VMS, the vehicle user can demand vehicle functions that he can subscribe to against a fee for one-time use, a certain duration or over the vehicle's lifetime. Examples for such functions could be premium on-demand autonomous driving functions, longer battery range, on-demand navigation, 3D video, AR/VR games, digital radio, etc. The requirement is that safety functions should not be part of such on-demand functions.

Based on user interests, services can be proposed to the customer actively through the app. Some of these on-demand functions will be directly displayed or linked to the VMS.

In the vehicle the VMS displays a choice of on-demand functions. The passenger can choose a function and the duration of the subscription through interaction with the VMS. Based on the VMS payment profile for that user deposited in the cloud, a passenger can pay after secure identification through the VMS. Alternatively, payment may not require a user profile and/or an in-app payment could be used. VMS confirms the purchase and displays the chosen function that is ready for use.

7.4.5.1 Requirements

R1: The VMS should enable a centralized or individual access in a multi-passenger vehicle to the cloud with app for on-demand functions and payment functions.

R2: For on-demand functions and payment functions, the VMS in a multi-passenger vehicle should have access to the VMS user profiles at a centralized or individual position.

R3: VMS should be equipped with sensors allowing the identification passenger(s) at different positions for usage and payment functions or with an input function allowing the user to identify himself through a password.

R4: VMS should support on-demand functions that are meant to run locally on VMS such as on-demand navigation, 3D video, AR/VR games, digital radio, etc.

- VMS must have enough storage space
- VMS must have enough calculation power
- For multi-passenger vehicles individual VMS at each passenger seat should respond to these prerequisites.

7.5 Continuous and consistent services across various networks and environment (from/to VMS)

7.5.1 Use case A – Continuity of service

During breakfast, a person starts to watch a live streaming of a basketball game using an APP on a tablet through the Wi-Fi network at home. After breakfast, the video of the basketball game is paused. Meanwhile, the viewing records (i.e., the program that is being watched, the time when the video is paused, the preferred audio commentary track, etc.) are uploaded to a cloud database automatically. The individual steps into a waiting vehicle and subsequently decides to continue to watch the live broadcasting of the basketball game en route to the office with the in-vehicle display or windshield display through the converged network. In the vehicle, the individual may log into an application in the VMS with the same user account to continue viewing. Meanwhile, the viewing records are downloaded from the cloud database to the VMS. In such a case, the account information and viewing records can be used to support continuous and consistent services across various networks and on multiple screens providing an improved viewing experience. For example,

- 1) Suppose the live streaming of the basketball game is available on both satellite broadcast networks and cellular communication networks. If the person has a premium subscription, then the high-definition (HD) live broadcasting of the basketball game with HD surround sound available on the satellite broadcast network may be enjoyed. If the person has a

non-premium subscription, then the service could be a best-effort live streaming of the basketball game available on the cellular communication network.

- 2) If the person decides to resume the play of the basketball game from the time that the video was paused previously, then the buffered recording of the basketball game on the cellular communication network should be supported. Meanwhile, the live stream of the basketball game on the satellite network may be available in a picture-in-picture mode.
- 3) When the person resumes the video of the basketball game on the application in the VMS, it should automatically choose the preferred audio commentary track based on the viewing records.

7.5.1.1 Requirements

To support continuous and consistent services across various networks and on multiple screens, the following requirements are proposed:

R1: The VMSP and the VMS should allow a user to log in with the same user account by using various devices, i.e., VMS itself, mobile phones, tablets, etc.

R2: The VMSP and the VMS should support the uploading of the user's viewing records to the VMSP.

R2.1: The VMSP and the VMS should support the configuration, by the user, of the scope of his/her viewing records that are to be uploaded.

R2.2: The VMSP and the VMS should support the configuration, by the user, of the frequency of his/her viewing records that are to be uploaded.

R3: The VMSP and the VMS should support the download of the user's viewing records to various devices.

R3.1: The VMSP and the VMS should support the configuration, by the user, of the frequency of his/her viewing records that are to be downloaded.

R4: The VMS should support the reception, processing, and display of multiple media channels from various networks and on different screens simultaneously.

7.5.2 Use case B – Cloud based services

Seamless connectivity between home, office and in-vehicle services will allow users to always find the same software applications, user interfaces, language, etc., regardless of their location (home, in the vehicle or at the office). Multimedia content, office applications and services will be the same. However, for security and confidentiality reasons corporate data will not be made available or be transferred to a VMS centrally managed user profile.

The VMS displays this content once the user is identified and allows access to individual data from the cloud or from the user's mobile phone.

7.5.2.1 Requirements

R1: A central user profile with content, applications and services excluding any corporate data is deposited in the cloud or locally in the user's mobile phone. Each user can have different profile versions, depending on the roles he can assume (on business, on leisure, family, etc.).

R2: VMS will identify driver/passenger(s) through its mobile phone (NFC, Bluetooth, other) or cameras or sensors (scan of fingerprint, iris, face, other).

R3: VMS will identify which seat in the vehicle passenger has occupied in order to display the right content at the right place.

R4: VMS accesses cloud content of passenger or the user provided profile of the mobile phone, displays it at the place user is occupying in the vehicle and adapts the passenger comfort of the specific place (seat and screen positioning, audio levels, temperature etc.). In case of multiple user profiles,

the user will be asked to choose the profile to apply or the VMS will choose the one that corresponds to the current situation.

- Changes made to the profile on the VMS within the vehicle, e.g., new applications, user surfaces, comfort choices etc. will be sent back from the VMS to the cloud, or stored to the user's mobile phone, where they will be saved and are accessible later from any other vehicle, at home or at work.
- Access of VMS to passenger specific cloud data from anywhere must be secured against intrusion and cyber attacks.
- VMS must have storage space to save profile data and to send them to the cloud when network coverage becomes available.

R5: Upon detection of change of the VMS user, the VMS should wipe personal data in order to respect privacy of the user.

8 Intelligent human machine interfaces (HMI) for VMS

In keeping with current development trends of intelligent vehicles, the integration of various interactive control schemes for safe driving such as voice control, gesture control, eye movement control, etc., will become mainstream in the future.

When interacting with the VMS there should be a distinction between input and output devices. All input and output devices should be intuitive, easy to use and be placed preferably in ergonomically areas so that they are easy to reach and allow simple interaction. Especially in driving levels 0 to 3 driver distraction and cognitive overload for the driver should be avoided so that the driver can safely operate the vehicle in all driving situations (hands on the steering wheel and eyes on the road) [SAE J3016].

Input devices allow the driver and passengers to input data and information into the VMS by directly interacting with the vehicle. The following input devices can be distinguished:

- Center stack and tunnel area
 - Touch screen(s)
 - Touchpad
 - Push buttons
 - Turn-press-knob
- Interior camera(s) for
 - Person identification (e.g., eye scanner, facial recognition)
 - Gesture control
 - Gaze detection/eye tracking
 - Driver and passenger monitoring (sensing, e.g., of drowsiness, distraction, emotional state, etc.)
- (Natural) Speech recognition
- Driver area
 - Steering wheel buttons
 - Touch screen on steering wheel
 - Fingerprint sensor
- Passenger areas
 - Touch screens

- Push buttons
- Intelligent surfaces (e.g., fabrics, cockpit surface, windows)

Output devices can give information specific to the driver as well as for all other passengers on board the vehicle:

- Driver area
 - Head-up display (HUD) (limited to driver, or augmented over a big part or the whole windshield)
 - Instrument cluster (numeric, or digital display)
 - Touch screen in the steering wheel
- Loudspeakers either in doors, or passenger specific for individual sound bubbles in headrests
 - Acoustic warning signals
 - Text-to-speech (e.g., reading of messages, mails, other information)
 - Sound (e.g., multimedia content, phone/video conferencing)
- Center stack display(s)
- Passenger displays
- Intelligent surfaces (e.g., fabrics, cockpit surface, windows)
- Ambient lighting (light integrated, e.g., around steering wheel, in cockpit, doors, etc.)

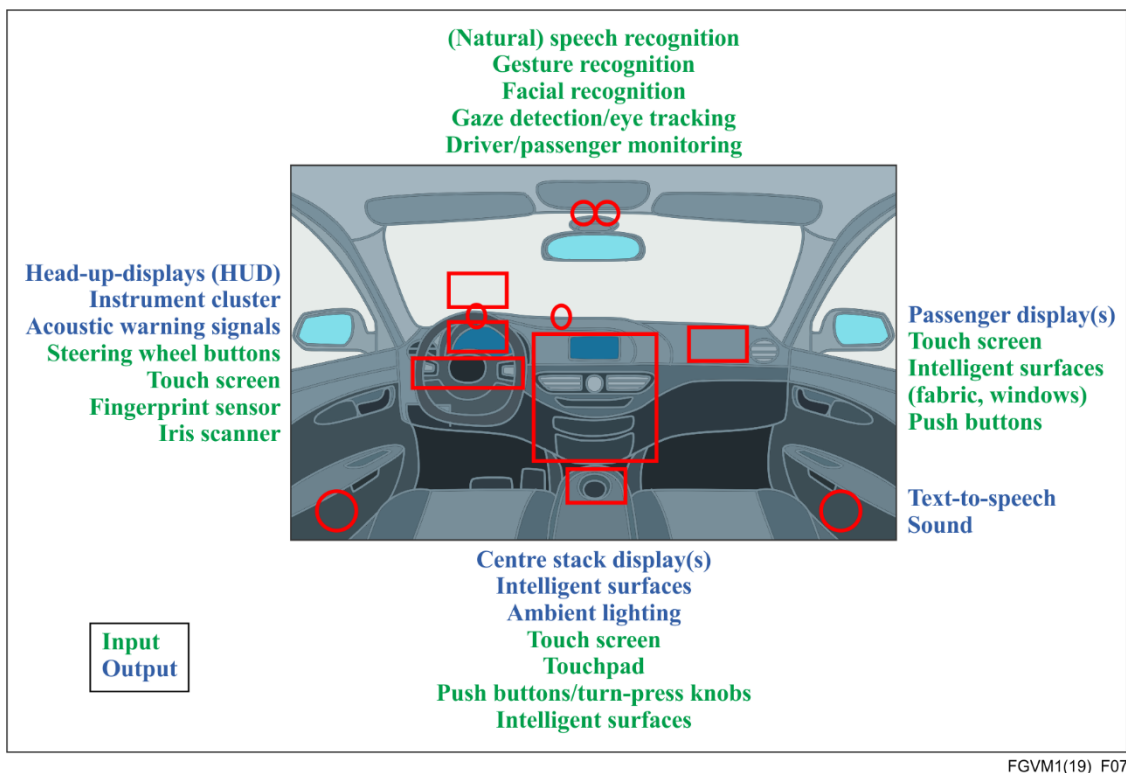

Figure 7 – VMS input and output devices, cockpit view

8.1 The acoustic system in the vehicular multimedia

8.1.1 Background

As stated in the terms of reference of the FG-VM, a vehicle may become a user's third entertainment space, and could be highly personalized. A VMS may support multiple screens and may be used not only to listen to radio but also possibly to watch television, movies, play games, either collectively or individually. At the same time a vehicle may comprise a voice recognition or natural language

processing system. It is expected that one or more multimedia sources and users interacting with one another or with a multimedia system will interfere with the voice commands.

It becomes apparent that the determination of the location (zone) of the various emitting sources (talkers) in the cabin and the acoustic treatment of each transmitted signal (voice command) from each location (zone) will facilitate the correct processing of voice commands by the voice recognition system.

8.1.2 Use-cases

8.1.2.1 Use case A – Initiating a voice recognition session

A person in a vehicle containing multiple occupants wishes to initiate a voice recognition session by uttering a keyword, such as "Hey Siri", "Alexa" or "Okay Google". Each occupant is in a separate zone of the cabin. The cabin may contain one or more microphones which may or may not be dedicated for each zone. Each microphone picks up the voice of the occupant, but also the voices of other occupants, or "interference speech". One or more multiple microphone signals (or audio channels) may be available to a keyword spotter (KWS), which must decide not only whether/when the keyword was spoken, but also from which zone the keyword was spoken.

The following problem scenarios may result in inadequate behavior of the KWS:

- A-1 If there is no dedicated microphone for each zone, or no means to identify the zone of the target talker, the command may not be detected, may be rejected or wrongly executed.
- A-2 Otherwise:
 - A-2-A Interfering speech may cause a KWS to fail to detect (false reject) the keyword spoken by the target talker in the target zone microphone.
 - A-2-B Concurrent sources (e.g., music, video) played into the vehicle, resulting in echo on the microphones, may cause a KWS to fail to detect (false reject) the keyword spoken by the target talker in the target zone microphone.
 - A-2-C Interference of the target talker onto microphones outside of the target zone may cause the KWS to detect the keyword but from the wrong zone.

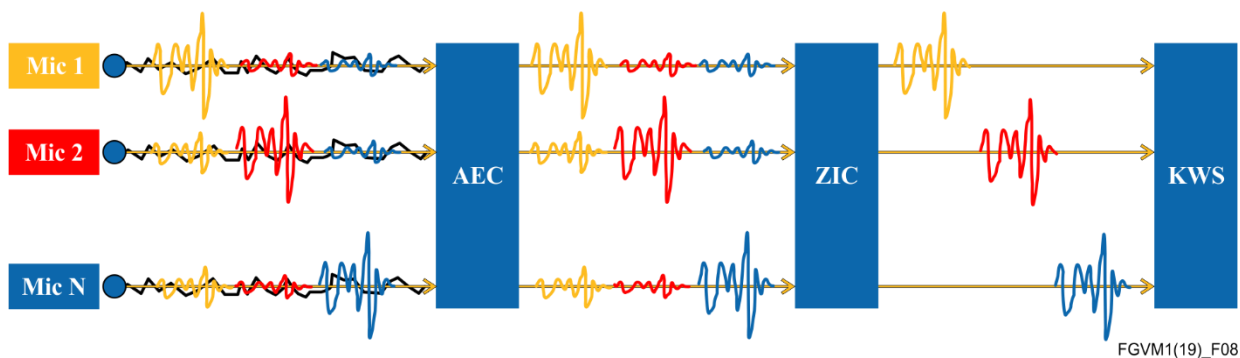

Figure 8 – Acoustic processing (AEC and ZIC) on each zone dedicated microphone

Figure 8 is an illustration of use case A-2 involving KWS with N microphones/zones in a vehicle, depicting the waveforms. Each microphone contains target speech, interfering speech and echo (black). Talker in zone 1 is yellow, talker in zone 2 is red and talker in zone 3 is blue. Acoustic echo cancellation (AEC) is used to subtract the echo from each microphone, and zone interference cancellation (ZIC) is used to isolate the target speech from interfering speech in each microphone.

8.1.2.2 Use case B – Interference during a voice recognition session

Once a voice recognition session has been initiated and the target zone has been identified (e.g., using KWS or push-to-talk), an occupant in the target zone will use voice commands to interact

with the voice recognition system. The target speech in the target zone will potentially be mixed with interfering speech from other zones, and echo from media sources playing into the cabin. These may result in incorrectly detected speech and difficulties in accomplishing the voice command.

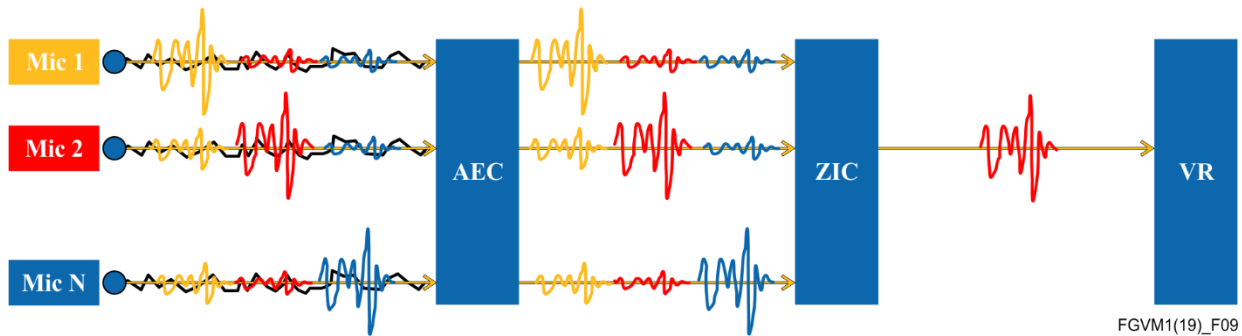

Figure 9 – Illustration of use case B, where zone 2 has been identified as the target zone

8.1.3 Gap analysis

ITU-T SG12 is currently working on a set of recommendations relevant for VMS:

- In car communication (P.ICC). P.ICC utilizes the integrated microphones and speakers in the motor vehicle cabin to amplify conversation to provide an improved communication between all occupants in a motor vehicle. Furthermore, it ensures the quality of voice such that the motor vehicle driver does not feel it necessary to turn their head to amplify their voice when talking to other passengers. However, it is not immediately apparent that P.ICC addresses the requirements associated with the use of voice recognition in a vehicular multimedia context.
- P11xx -00,10,20,30 series. Hands-free communications in vehicles for narrowband, wideband, super-wideband and full-band and associated subsystems provides useful conformance points to improve signal processing for hands-free communication within a vehicle. However, it is not immediately apparent that the P11xx series can address the use cases and requirements for multiple talkers, KWS, voice commands and voice recognition sessions.

8.1.4 Requirements – Acoustic

In order for a KWS, a voice recognition or natural language processing solution to operate effectively in a multiple-talker scenario with background media in a vehicle, the following requirements are proposed:

R1: It shall be possible to initiate a voice recognition session from any zone in the vehicle.

AR1.1: It shall be possible to initiate a voice recognition session from any zone in presence of speech interference and noise interference from the same or a different zone.

R2: The VMS or vehicle should provide at least one voice/speech/audio channel per zone (e.g., one microphone per zone).

R3: It shall be possible to process each channel/zone independently.

R4: It shall be possible to identify a target zone/target speech (e.g., scenario A-1).

R5: ZIC shall be performed to suppress interfering speech from a zone whilst preserving the target speech in that zone. (scenarios A-2-A, A-2-C and B).

R6: AEC shall be performed on each channel to suppress the echo of media sources that are picked up in each zone (scenario A-2-B).

R7: When interfacing with cloud recognition services that are not trained specifically with vehicle noise, it should be possible to perform noise reduction in the target zone to suppress road noise or wind noise.

8.2 Gesture control in vehicular multimedia system

Applying gesture recognition as part of intelligent human machine interface (HMI) and of ADAS can improve driving safety. Drivers can use gesture to control various functions, including in-vehicular multi-media functions, or change various settings, such as the temperature of air-conditioners or sound volume in the vehicle, thus paying more attention to the road and reducing the occurrence of traffic accidents.

Through a simple and easy to use gesture control system, drivers can interact with multimedia system functions while looking directly at the road ahead.

8.3 Eye-movement control in vehicular multimedia system

8.3.1 Real time eye gaze tracking scenario

Eye gaze tracking is the process of measuring either the point of gaze (where one is looking) or the motion of an eye relative to the head. An eye tracker is a device for measuring eye positions and eye movement. With the progress in processor speed and image processing algorithms, it is now also possible to use the gaze tracking technology in real time to control a screen pointer in a direct manipulation interface. Eye gaze tracking technology is well explored for consumer electronics and gradually making way to the automotive and aviation sector. It has already been explored for the attention analysis of drivers and pilots and designing cockpits to minimize eye gaze movement, highlighting critical elements and so on. The following use cases emphasize real time use of eye tracking in a moving vehicle as a direct controller of electronic displays inside a car and to analyse drivers' cognitive load while driving.

- Driver wants to change radio channel or accept a call. He does not need to take his eyes off the road nor look down at the dashboard, and neither to take his hands off the steering wheel. The whole dashboard is reflected on a heads up display and he operates the display just like any graphical user interface through fixating attention on the required icons. The fixation duration is less than 2 seconds and even when he is operating the display, he can use his peripheral vision to observe the road.
https://en.wikipedia.org/wiki/Two-second_rule
- Driver is distracted, feeling stressed or bored, eye tracker detects driver's state from ocular parameters like pupil dilation or fixation rate. Based on the gaze tracker inputs the ADAS system that will trigger the VMS to reduce secondary task load (e.g., VMS media playback) and alerts driver and passengers.
- Eye tracker tracks eyes of passengers of an autonomous vehicle. The VMS uses it to operate entertainment systems on back seats and can be used to alerts passengers if the passenger in driver's seat is distracted or stressed.



Figure 10: example of interactive eye gaze controlled HUD

8.3.1.1 Gap analysis

Required improvement for the use of eye gaze trackers in automotive environment includes:

- Commercial eye gaze trackers which have not yet been tested for automotive compliance
- Robust algorithm for affective state detection
- Improving accuracy and latency of commercial eye gaze trackers in automotive environment
- Combining eye gaze control system with other existing modalities
- Testing the accuracy of driver distraction and affective state detection system in automotive environment.

8.3.2 Use case – Gaze tracking

A dynamic HMI responds to the user's gaze. Elements of the UI can be configured to change based on whether or not the user is looking at them. For example, an element on the screen can be set to be transparent when the user is not looking at it, and immediately return to the visible state once the user is looking at it.

Controlling the vehicle multimedia by eye movement can be implemented to improve driving safety.

8.3.2.1 Requirements

R1: Accuracy and latency requirement for gaze control system integrated for use in the HMI of a VMS shall not require fixating attention for more than 2 seconds or the maximum time defined by local regulations in automotive environment on the HMI.

8.3.3 Use case – Controllable camera through eyes

Users can also control an external camera through their eyes, which is similar to the head-tracking camera.

NOTE – This is not a DVR camera which is mandated in certain country to record. DVR camera are not user controllable.

8.4 Data formats and storage

8.4.1 Use case and considerations

There is a need to define a minimum set of data formats to be supported by a VMS to allow for interoperability between different VMS and different VMNS providers. The following aspects should be considered:

- Codecs (and protocols) used by broadcast and interactive systems to and from a VMS.
- Contents on nomadic devices (mobile phones) when connecting to the VMS (e.g., to share content via the VMU).
- Existing codecs usually supported by current infotainment solution.
- Additional sensors and their storage/compression requirements for VM system services (e.g., maps, AR, telematics).

The main ECU may be built on a powerful processor, while processors with lower capabilities (e.g., limited set of codecs) may be available in the vehicle (e.g., with mounted display in back seat positions). As such, it can be desirable to transcode content received at the main ECU in formats supported throughout the vehicle.

Further, as the amount of data exchanged between device and infrastructure is becoming a bottleneck, evaluation of codec performances (compression, lossless/lossy capabilities) should be taken in account when deciding on codec support. In the context of a VMS, this data comprises at least audio, video, images and point-cloud (such as lidar) which can be used both for entertainment and safety purposes.

In addition, VMS and VMU will need to support software updates. These updates and software codecs should be securely provided. Their use and access by different VMNS may be restricted.

8.4.1.1 Requirements – Data format

For multimedia broadcasting services provided by a VMNS service provider, the media types, content navigation methods and interactivity methods supported by a VMS and VMNP shall be selected from the recommended format in [ITU-T BT.2055-1].

Additional media types may be supported by the VMS and the VMNP to address some regional requirements (e.g., support of AVS2 codecs in China).

A VMN application may support additional software codecs to address the need of a VMNS service provider.

For interactive, and non-broadcasted VMNS, the VMNP and VMS:

- Should support the same multimedia broadcast media types
- May support JPEG-XS
- May support MPEG-H 3D audio

NOTE – The selection of media types and transmission protocol formats (e.g., MPEG-DASH, MBMS, etc.) will be refined after the architecture phase.

9 Privacy considerations

9.1 Background

A VMS could have the following characteristics:

- 1) Be available on a connected vehicle (or/and autonomous vehicle)
- 2) Be personalizable, like a phone, a subscription or a service tailored to the user and to the user's interests

Countries and states have started to regulate connected vehicles or release broad privacy regulations. Among them:

- The US Department of Transport requires, among other things, that connected vehicle safety applications messages shall not contain any personally identifying information (PII). [DoT PII-1]
- In Europe, the general data privacy regulation (GDPR) came into effect in May 2018 and requires, among other things, that only the minimum necessary personal information are collected, consent shall be obtained in a clear manner, collected data shall be accessible by the user and data shall be deleted when no longer relevant or when consent is withdrawn [DoT PII-2]
- In China, the Cybersecurity Law of the People's Republic of China came into effect in June 2017 and requires that network operators collecting and using personal information shall abide by the principles of legality, propriety, and necessity. Besides, a guideline for Internet personal information security protection is being formulated to ensure that the rights of data subjects are not to be violated.

Further, the following scenario should be envisaged:

- The vehicle is owned by the user of the VMS
- The VMS may be temporarily used by different individuals (driver or passenger) of the vehicle, for instance in a family, shared car, rental car, or taxi model.
- The personalization of a VMS may be provided by a centralized service provider.

In network communication protocols, at various layers identifiers are used to identify software and hardware (e.g., IP address, MAC address, E.164 "phone number", etc.). Some of these identifiers constitute PII in some instances, and protocol designers in the past did not always take this into account. In the design of systems and protocols today, there needs to be intentional separation of PII identities (e.g., username, email address [IETF email] and [ITU-T E.164]) and non-PII identities (e.g., IP address, MAC address, etc.) used at various layers in the communication stack.

Further, user's privacy and PII (such as viewing history, history of interactions, profiles and preferences) needs also to be protected in interactive broadcasting system, both at the broadcast receiver (e.g., the VMS or VMS application), on the interactive link and at the service provider level as highlighted in [ITU-R BT.2052].

From the above it becomes apparent that VMNS needs to allow for different use cases under different regulatory requirements. The high-level privacy requirements in clause 9.2 are proposed:

9.2 General privacy requirements

R1: The VMN and VMS shall be designed to allow for its use under different privacy regulatory environments.

R2: The VMN and VMS shall prevent network-layer identifiers (such as MAC address) to be used as personally identifying information.

R3: The VMS shall protect any permanent hardware identifiers and only allow access for authentication purposes.

R4: In addition to the specified requirements for in-vehicle entertainment and multimedia systems, it is required that users' (driver, passengers) privacy be protected, and that private conversations not be directed to the voice-recognition system, be protected and that un-authorized sharing of such conversations be hindered.

R5: Consideration should be given to the case where the voice recognition system is in-vehicle or is cloud-based.

R6: The VMS should have the capability to wipe personal data transferred through the mobile device connected to the VMS in order to respect privacy of personal data.

9.3 Use case – Private vehicle with one single user

The end user is identified when entering his privately-owned vehicle. VMS cloud platform has access to the agenda of vehicle owner. It therefore knows if the user is driving to a meeting, a birthday party, a restaurant, etc., and the time of arrival at the destination. Based on the time of day and geo-localization of the vehicle, the platform sends proposals to the VMS that are displayed on the VMS or read to the end user through the VMS (text-to-speech) e.g., restaurant reservation before a meeting, buying flowers on the way to a dinner or a gift on the way to a birthday party, etc. The vehicle user can through direct interaction (voice recognition, touch screen, other) with the VMS make use of these proposals or deny proposals. Furthermore, having deposited payment preferences in the cloud, the vehicle owner can directly pay through the VMS. Based on the inputs into the VMS, the vehicle might be rerouted to another itinerary in order to pick up the goods or to go to the restaurant chosen during the ride.

9.3.1 Requirements

R1: VMSP should have access to a commercial platform linking location-based data with the information of shops, restaurants and current commercial offers.

R2: VMS should have access to personal payment data that are deposited in the cloud.

R3: VMS should have a feature for secure identification of the user before payment process (e.g., fingerprint sensor, iris scanner).

9.4 Use case – Long distance shared vehicle with multi users (shuttle all users are seated)

End users are identified when entering the shuttle. Each user of the shuttle has his own seat in the vehicle. VMS identifies where they are seated within the shuttle in order to adapt content, based on the capabilities of each seated position (some might have screen, some just audio, the possibility of seat comfort adaptation etc.). VMS has access to agenda or agenda parts of each shuttle user (either from the cloud, following authorization from the user, or from the user's mobile phone). The itinerary has been optimized in order to bring each vehicle user on an optimized route within the shortest time to its destination. In addition, due to the link of the cloud platform with the agenda of the multiple users, the VMS knows for each single user if he drives to a meeting, birthday party, etc. Based on optimization algorithms the VMS proposes services (restaurant reservations, buying flowers or a gift) to each individual shuttle user based on his respective agenda. Each vehicle user can pay through direct interaction with its VMS within the shuttle.

9.4.1 Requirements

R1: VMS should have the ability to identify the different users and retrieve their personal and payment data.

R2: VMS should support receiving agenda and personal information from user mobile devices.

R3: VMS can allow the user to enter destination without revealing his agenda and other personal information (via dedicated application, or in-vehicle screen with coordination and synchronization with user mobile phone).

R4: The VMSP with data concerning destination and agenda of all users of the shuttle and the commercial decisions all users take, should provide these data to the cloud navigation application and receive from it, an optimized proposal for the different users and for the routing of the shuttle.

R5: User can at any time change itinerary, overwriting agenda information and previous instructions in the VMS.

R6: Upon detection of change of the VMS user, the VMS should wipe personal data transferred through the mobile device connected to the VMS in order to respect privacy of personal data.

9.5 Use case – Public transportation shared vehicle with multi users (shuttle short distance trips – seated and standing users)

End users are identified when entering the shuttle (via RFID, mobile phone NFC, or face recognition for registered users). VMS identifies the position of the user in the vehicle.

VMS has access to agenda or agenda parts of each shuttle user (either from the cloud, following authorization from the user, or from the user's mobile phone). The itinerary has been optimized in order to bring each vehicle user on an optimized route within the shortest time to its destination.

VMS provides personalized information on the public display in the bus informing users when approaching their bus stop (by preserving their privacy). VMS can send messages to mobile or wearable devices of user with more private information, if this is authorized by the user.

VMS presents infotainment information on the public screens, based on interests of the user and their proximity to the screen. As the journey progress, information about the city, about events near to the route, about special offers of shops in the trajectory and other interesting information that are displayed on the public screen. User can also ask to send this information directly on their smart device while on board the vehicle.

9.5.1 Requirements

R1: VMSP should be able to push non- personalized messages on VMS or directly on user's mobile devices when users have opted in to the service.

R2: Connectivity from mobile devices to VMS is possible.

R3: VMS can receive agenda and personal information from user mobile devices.

R4: VMS can allow the user to enter destination without revealing his agenda and other personal information (via dedicated application, or in-vehicle screen with coordination and synchronization with user mobile phone).

R5: VMSP with data concerning the destination and agenda of all users of the shuttle must optimize content proposals to the different users and the routing of the shuttle.

R6: User can at any time change itinerary, overwriting agenda information and previous instructions via VMS or via their mobile phone.

R7: User should have the possibility to opt-in or opt-out of the service at any time either through an interface of the VMS or through its mobile device.

R8: Upon detection of change of the VMS user, the VMS should wipe personal data transferred through the mobile device connected to the VMS in order to respect privacy of personal data.

10 Content rights protection in a converged network environment

10.1 Background

The convergence of different networks combines features of uni-directional networks and bi-directional networks. Such converged networks provide a variety of advanced multimedia information services to vehicle terminals, i.e., live television service, online video streaming service, multimedia content delivery service, etc. The architecture of the converged networks is illustrated in Figure 11.

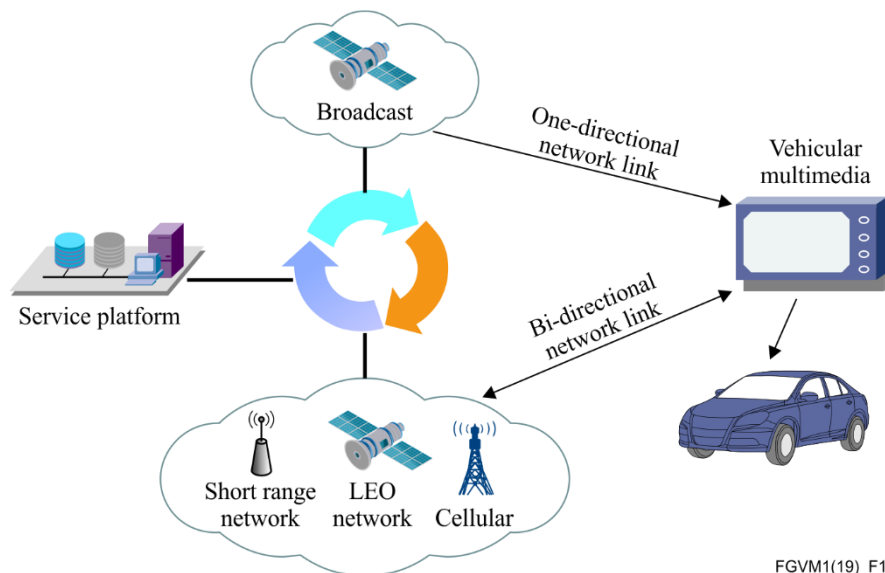

FGVM1(19)_F10

Figure 11 – Convergence of different networks for vehicular multimedia content

Consider live television service as an example. Currently, live television service is delivered solely by satellite broadcast network. To protect the television video content from being received at unauthorized terminals, the following conditional access (CA) technique is applied. The architecture of the satellite broadcast system with CA support is illustrated in Figure 11. At the head end, the multimedia stream for each channel is scrambled by a control word (CW). The CW is encrypted by the product key (PK) to obtain the entitlement control message (ECM). The PK is encrypted by the personal distribution key (PDK) to obtain the entitlement management message (EMM). Scrambled data, ECMs, and EMMs are multiplexed into a transport stream (TS) before it is transmitted over satellite broadcast channels. At the terminal, the transport stream is demultiplexed to recover the scrambled data, ECMs, and EMMs. Then, the PK is decrypted from the EMM by the PDK stored at the CA terminal. Next, the CW 1 for channel 1 is decrypted from the ECM by the PK. Finally, the multimedia stream for channel 1 can be obtained by descrambling the data for channel 1 with CW 1. Note that PDK is unique for each terminal, and, therefore, the EMM for a terminal would be different from those for other terminals. By using the above CA technique, for each terminal the access to the live television service can be controlled (i.e., access to the content is either allowed or denied).

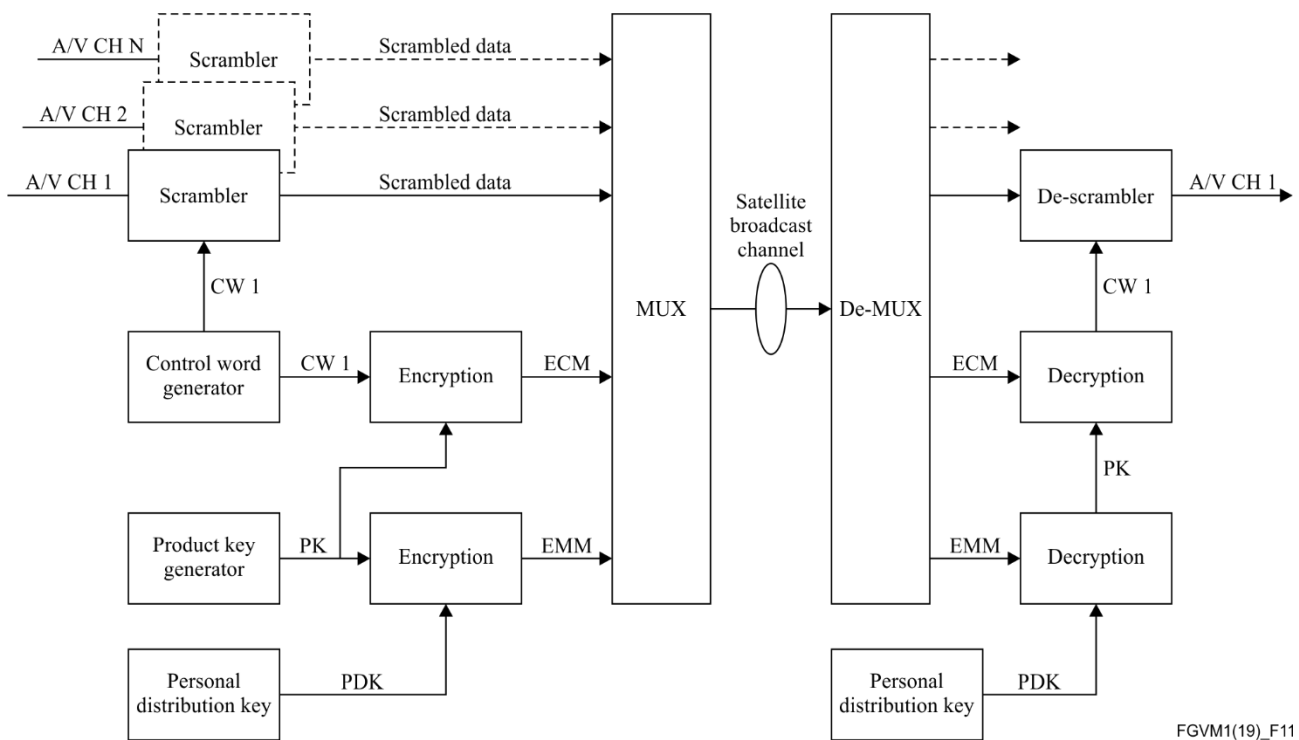

FGVM1(19)_F11

Figure 12 – Diagram of the satellite broadcast system with CA support

10.2 Use cases

The conditional access system shown in Figure 12 has several drawbacks. In the following use cases, the limits of the above conditional access system are analysed and solutions to improve the system performance with converged networks are described.

10.2.1 Use case A – VMS with flexible EMM

Consider a live television broadcast service delivered solely by satellite networks. In such a case, the scrambled multimedia data for each channel, ECM for each channel, and EMM for each terminal should be transmitted over the satellite broadcast channel. Typically, the size of an EMM is about dozens of bytes. If tens of thousands of new users are trying to activate their devices in a short period of time, then the bandwidth required for the transmission of the EMMs for these new devices may not be available in a satellite broadcast channel. As a result, some of these users may experience service activation delay or failure.

For a service operator with access to converged networks, such circumstance could be avoided by offloading the EMM transmission to the cellular communication network. The architecture of the multimedia system with flexible EMM transmission is illustrated in Figure 13, where the scrambled data and ECMs are transmitted over satellite broadcast channel and the EMMs are transmitted over cellular communication networks.

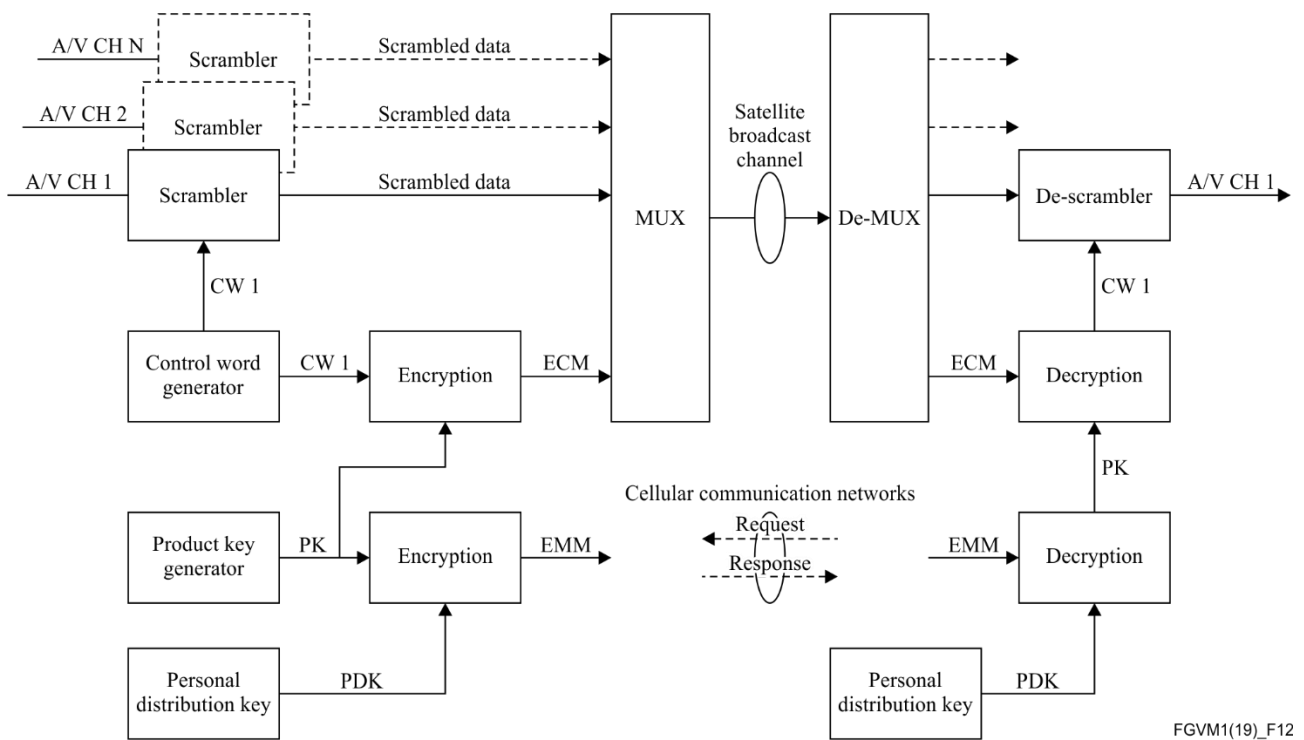

FGVM1(19)_F12

Figure 13 – Diagram of the multimedia system with flexible EMM transmission

10.2.2 Use case B – VMS with extended EMM

Bearing in mind that the conventional conditional access system could support simple access control at terminals, i.e., the play of multimedia streams can be either allowed or denied at a terminal. However, for vehicle multimedia service operator, more rights control options shall be available. The following should be noted for a live television programme:

- 1) the reception of this live television program should be controlled (i.e., allowed or denied);
- 2) the recording and local storage of this live television program should be controlled (i.e., allowed or denied);
- 3) if the recording and local storage of this live television program is allowed, then a maximum number of plays of the recorded video can be set;
- 4) the forwarding of this live television program to other nomadic devices in vehicle should be controlled (i.e., allowed or denied).

To support the above rights control options, rules shall be delivered from the head end to the terminals. For each terminal, specific rights rules may be applied. For example, specific to each terminal, the rights rules can be delivered together with the EMM over the cellular communication networks. A diagram of the multimedia system with extended EMM to support more rights control options is shown in Figure 14, where the scrambled data and ECMs are transmitted over satellite broadcast channel and the extended EMMs are transmitted over cellular communication networks. Note that this is a general framework and the specific scheme to achieve rights rule control at terminals is an implementation issue.

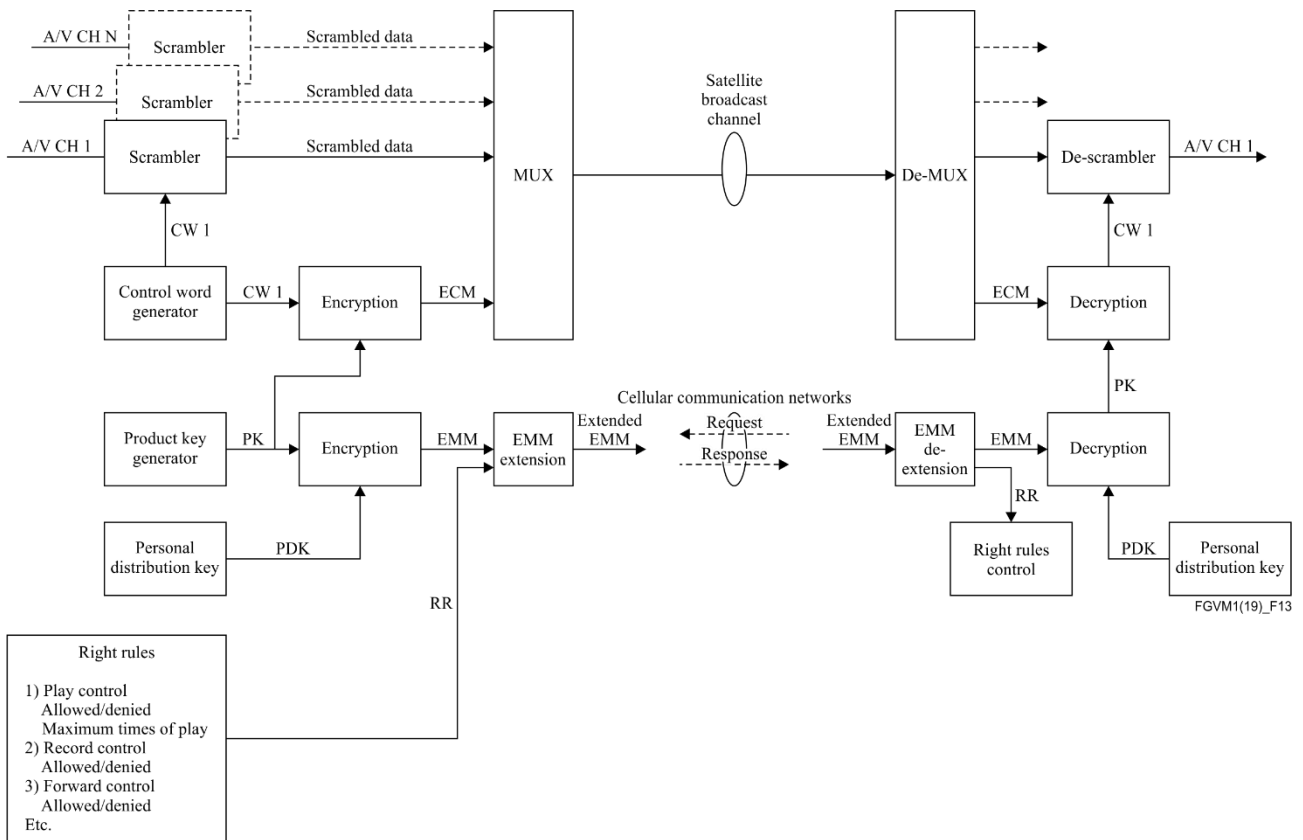

Figure 14 – Diagram of the multimedia system with extended EMM to support more rights control options

10.3 Gap analysis

At present, multimedia information service is mainly based on either the unidirectional network or bidirectional networks.

For multimedia information system based on unidirectional networks, the following conventional CA schemes can be applied to provide simple access control at terminals. Two major drawbacks for such systems have been analysed in clause 10.2.

- 1) ETSI Standard: Support for use of scrambling and Conditional Access (CA) within digital broadcasting systems ETSI ETR 289 ed.1 (1996-10) [ETSI ETR 289]
- 2) ATSC Standard: Conditional Access System for Terrestrial Broadcast (A/70 Part 1:2010) [ATSC]
- 3) China's radio and television industry standard: Specification of conditional access system for digital television broadcasting GY/Z 175-2001 [CN-CAS]

For multimedia information system based on bi-directional networks, the following conventional digital rights management (DRM) schemes can be applied. A major drawback of such schemes is that they cannot be seamlessly integrated with conventional conditional access schemes. Nevertheless, the concept of rights rules in these DRM schemes can be used to enhance the conventional CA schemes.

- 1) Open Mobile Alliance: OMA digital rights management (DRM) [OMA DRM]
- 2) ChinaDRM: Technical specification of digital rights management for internet television, GY/Z 277-2014 [ChinaDRM]

10.4 Requirements – Content rights protection requirements for CA

The requirements for the content rights protection in converged networks are as follows.

R1: Conventional conditional access schemes for unidirectional networks may be supported.

R2: Entitlement management messages in conventional CA schemes may be delivered over bidirectional networks.

- a) A CA agent on the VMS should support transmitting a request of its EMM to the head-end.
- b) The head-end should support transmitting a response with the EMM to a terminal.
- c) The head-end may push the EMM to a VMS without being requested.

R3: Rights rules for a terminal may be transmitted along with the EMM to the terminal.

R4: Rights rules for a terminal may be transmitted in an independent message to the terminal.

R5: The integrity of rights rules for a terminal shall be guaranteed during its transmission from the head-end to the terminal.

R6: The rights control options shall be extensible for additional rules to be added in the future.

11 Copyright and rights management support for content delivery

11.1 Use case – Content payment and copyright protection

For some content providers the in-vehicle-screen and mobile phones are two different distribution channels with different service cost and price offering. The price for an end-user to receive content in a vehicle can be different on a mobile phone than on the in-vehicle-screen. Sometimes the end-user should pay again to enjoy the same content in a vehicle while the content was already paid for by mobile phone consumption. Alternatively, a content provider may allow its users to enjoy the same content freely in vehicle if users have a paid content subscription for mobile phone consumption.

These different commercial policies across distribution channels should be enabled by the VMN and VMS. The VMN should enable content providers to manage content-services-fee-payment across distribution channels.

11.1.1 Requirements – Copy protection

R1: The design of the VMS should be capable of preventing multi-media contents distributed to the VMS from being copied from the VMS to mobile phones and/or be redistributed through the VMS hardware to external devices.

NOTE – This does not include the possibility that users record screens with other recording devices.

11.2 Privilege and account management

11.2.1 Use cases

11.2.1.1 Use case A – Parental control

Parental control may be enabled for children or teenager passengers to prevent access to restricted content.

An identification (ID) system (e.g., traditional ID such as mobile phone number or biometric technology ID such as face or voice recognition) and corresponding database may be necessary to carry out parental control. The passenger may be identified as either an adult or a child.

11.2.1.2 Use case B – Content classification

To enable content and services rights management, identifying content classification may be necessary to replicate common practice for multi-media content on other channels (e.g., movies in theatre versus DVD). Content and services can be classified into different categories, based on age or subscription status.

11.2.1.3 Use case C – Privilege management in single use vehicle

Depending on different business models, content and service privilege management may differ.

An original equipment manufacturer (OEM) vehicle maker may have a business agreement with a content or service provider. The OEM vehicle maker has paid for the subscription fee for its customers. The vehicle owner, upon acquiring the vehicle can receive the content subscription for personal use, but only in this very vehicle. In this situation, privilege management is based on hardware identification, as the objective of the OEM vehicle maker by paying for the subscription is to sell more vehicles by offering such services and entertainment content privilege.

11.2.1.4 Use case D – Privilege management in shared vehicle

In the car sharing industry, several different business models lead to differing requirements for the VMS. One vehicle will welcome many different passengers per day. There are two categories of companies in the car sharing industry:

Category A,

Rental companies who provide only vehicles without drivers may pay content/service subscriptions for their customer as a strategy to enhance their market competitive strength. In that situation, the subscription may be associated to a *vehicle hardware identifier*. In addition, such rental company can also allow users to log into their own third-party content providers accounts to guarantee a similar user experience on the rental car, consistent with the one on a user's own private vehicle.

Category B,

For taxi companies, who are not only providing vehicles but also drivers, the number of customers is higher than for companies in category A. It can be very difficult to satisfy all passengers by a content/service subscription tied to the vehicle hardware as it may be impossible to predict what kind of music the next passenger may enjoy or desire to hear. For these companies, a better system may be to enable access to cloud-based content/service by each customer based on a *user identifier*.

Independently of which taxi a user is sitting in, as long as the user logs into his or her account, the user can immediately enjoy the same services and the same user-experience in different vehicles. The VMS will retrieve the user history, default recommendations, and other user-specific data from the system.

11.2.1.5 Use case E – Privilege management for local media content

Hardware and/or software suppliers may pre-load content made by themselves into vehicles (local media content). User's privilege management for local media content could differ from third party's online media content.

11.2.1.6 Example of mapping of different ID system

Figure 15 is an example illustrating how two ID systems (User ID and IVI/hardware ID) can be used concurrently to provide a multimedia service.

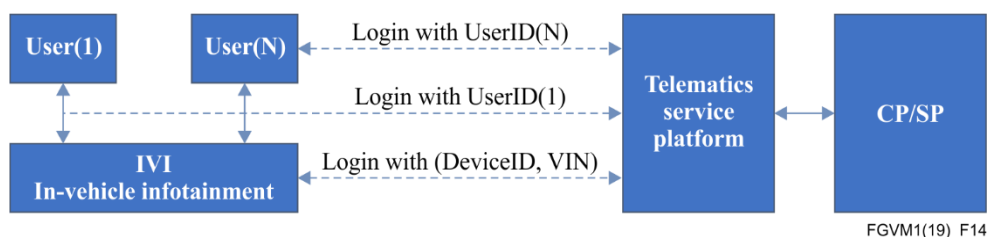

Figure 15 – ID systems

For devices, "Device ID" or "Vehicle Identification" (such as a VIN code) or other identifiers may be used to log into OEM vehicle maker management platforms (e.g., telematics service platform).

For end users, "User ID" may be used to access services and to obtain personalized content and recommendations.

NOTE – Privacy and regulatory aspects will need to be taken in account when selecting specific ID mechanisms.

11.2.2 Requirements

11.2.2.1 Privilege management requirements

R1: VMN should protect and manage all content copying on the platform.

R2: User classification (e.g., based on age) and content classification is needed to carry out multi-media service privilege management.

R3: VMN should support parental control function.

R4: VMN may support an ID system and corresponding database to enable content rights and privilege management and to provide customized services.

Example of user-ID may comprise mobile phone number and/or biometric (e.g., face recognition, voice recognition, or finger-print information, etc.).

R5: VMS should be able to apply privilege management to preloaded content associated with VMS hardware. When restrictions apply, the VMS should prevent copying the preloaded content to other devices.

NOTE – As long as there is a local record of a subscription on the VMS, user can enjoy the privilege in that vehicle.

11.2.2.2 Account management requirements

R1: The personalization of the multimedia portal should be enabled by the VMN account management system.

R2: The VMS should support multiple users to login concurrently in the same vehicle with different user IDs for personalization purposes.

R3: After logging in with different IDs, the displays of VMS for different users may be personalized, including greetings, interfaces and services.

R4: If one user logs into different vehicles with the same user ID, then the VMS may support retrieving and displaying the user personalized interfaces and recommended contents to ensure a consistent user experience across VMS enabled vehicles.

R5: The VMS should be capable of matching a vehicle hardware ID (such as key fobs or biometric based ID system) with user IDs to enable access to third party services (e.g., content provider or services provider). VMS should be able to access IDs available locally and in the cloud.

11.3 Payment services in shared vehicle

11.3.1 Use case – Time shared vehicle

Passengers of a time-shared vehicle in exclusive use (drivers and/or passengers, no additional passengers will be picked-up during the journey) are identified (for example by facial recognition, fingerprint, iris scan, RFID in personal ID card, etc.) when entering the vehicle and then identified at each individual seat by the VMS. These passengers have deposited their payment preferences in the cloud. The payment of services and goods like parking, fuel, charging of the EV, food at a drive-in, and usage fees for a shared vehicle will be executed after confirmation through the VMS based on person identification and payment preferences.

For multi-passengers in a shared vehicle the person who has initiated the process, e.g., parking, charging, refueling, drive-in will be asked by the VMS if he wants to pay individually or if he would

like to share costs with the other passengers. In case this person wants to share costs the VMS dispatches messages to the individual VMS's of the other passengers asking confirmation of the other passengers for participation in the payment. These passengers confirm or deny the payment at their individual VMS within the vehicle using, e.g., touch screens, voice, mobile phone confirmation or other available means (like scanning RFID identification card, replying to keyword challenge they have previously established).

11.3.1.1 Proposed requirements

R1: VMS may have access to different cloud platforms in which the different users have deposited their personal and payment data. In case user has no payment profile VMS should support payment through credit card.

R2: The VMS shall be able to dispatch VMS messages and processes to individual VMS terminals within the vehicle

R3: VMS should be able to connect to user personal mobile phone for personal information, communication, and confirmation in case vehicle would not be equipped at all seats with displays and vehicle VMS interfaces.

R4: Upon detection of change of the VMS user, the VMS should wipe personal data transferred through the mobile device connected to the VMS in order to respect privacy of personal data.

12 Security

12.1 Use Case – User data protection

As vehicles become connected and offer more interactive services, more user data and privacy-related information (such as users viewing preferences and habits) could be generated and stored in the VM system (vehicle) and in the VM service (cloud/servers). The user data and privacy-related information should not be transmitted between systems without user consent. Similarly, these data should not be accessed by another system without user consent. When the user data and privacy-related information are transmitted between systems, the protection of user data shall be ensured and becomes an important consideration in the performance and security evaluation of vehicle multimedia systems.

The system should guarantee that the user data cannot be given to third parties without explicit authorization from the user.

12.1.1 Requirements

R1: The in-vehicle multimedia platform should provide end-to-end data protection to ensure confidentiality and integrity of user data, including data protection at rest in local terminals, during transmission over different channels and when processed at the cloud platform.

12.2 Use Case – VMN application security

A VMN application should be securely developed according to best practices and applicable local regulations and not bring additional risks within the vehicle and should not be tampered with or corrupted.

12.2.1 Requirements

R1: In order to verify the application and to ensure its origin authorization, a VMN application should be signed.

R2: The VMS should be able to verify the signature of the VMN application in actual use prior to allowing access to APIs (e.g., communication APIs)

R3: It shall be possible to wipe all the data (application, content and data) on the VMS to return the VMS to its factory settings.

R4: It shall be possible to wipe a subset of the data on the VMS.

R5: The wipe shall be able to be performed by different authorised entities such as the VMNS service provider, the end-user or the VMS manufacturer.

12.3 Use Case – VMS software security

Due to increasing system complexity, software error or software fault may exist in VMS, which may cause crashes. The system should guarantee that such fault would not cause operation errors or abnormal stop that would threaten security, and would cause the entire vehicle system may not work properly.

12.3.1 Requirements

R1: The vehicular multimedia systems shall be segregated from other vehicular control systems to avoid the failure and system fault of the whole vehicle systems. The vehicular multimedia systems should also provide physical or logical access controls for the isolation of sensitive applications, application data, or systems.

13 Safety

13.1 Use case – Driving safety: Speed control

Before L4 and L5 autonomous vehicle are commercialized, consuming audio and video content in vehicles will easily be a cause for driver's distraction. In accordance with local regulation, when the vehicle speed reaches a certain threshold (it differs based on local regulation, for instance from 0 kilometer to 15 kilometers per hour), the VMS shall automatically block entertainment content on the driver-side display. Speed control is a common practice already in use in countries around the world.

Requirement:

R1: In accordance with local regulation, when the vehicle speed is above a given threshold, the VMS shall be able to automatically block entertainment content on the driver-side display.

14 Definition of vehicular multimedia configurations

As smart connected vehicles are more broadly available, vehicular multimedia services are becoming richer and more complex than before. Vehicular multimedia configurations for smart connected vehicle could be used to manufacture and qualify vehicles accordingly. Customers can know which multimedia capabilities his/her vehicle multimedia offers.

14.1 Use case – Vehicular multimedia configurations

Currently, when customers choose a vehicle to acquire, the vendor of the vehicle generally provides them with a limited configure sheet which may not have detailed information on the multimedia capability of the vehicle (e.g., FM/CD/DVD and some other storage disk such as USB disk/SD card/TF card). With the specification of VMS, and the deployment of smart connected vehicle/autonomous driving/ADAS, vehicular multimedia system (VMS) configurations should be

defined and include network connectivity, media display, HMI controls, PII protection and security capabilities.

1) Networks connectivity capabilities:

VMS configurations should support one or more of the following:

- 3G/4G/5G/ cellular networks.
- Low earth orbit bi-directional communication networks (e.g., Starlink, Oneweb, HongYan, Hong Yun).
- Satellites broadcast (e.g., L Band Broadcast).
- Satellites bi-directional communications (e.g., TIAN TONG No.1 Satellite).
- Short range networks such as WLAN or Wi-Fi.
- Terrestrial broadcast networks (e.g., FM, DAB, HD radio, CDR, DTMB).
- V2V and V2I networks (e.g., DSRC/LTE-V/5G PC5).
- Brought-in, built-in and hybrid connectivity.

2) Media display and media format capabilities:

VMS configurations should support one or more of:

- Text.
- Image.
- Audio: Normal audio and high fidelity audio.
- Video: Normal video, 4K/8K video, AR and VR.
- Holographic projection and image.

3) HMI control capabilities

VMS configurations should support one or more of the following:

- Button
- Touch screen
- Intelligent control (speech control/gesture control/eye movement control)

4) Personally identifying information protection capabilities

5) Security capabilities.

14.1.1 Requirements – Vehicular multimedia configurations

The above five capabilities may be considered as the main aspects to define a set of VMS configurations.

Moreover, different regions for the above aspects should be taken into consideration. The configurations should allow for geographic flexibilities to adapt to the regulatory requirements of different countries.

NOTE – Configurations may apply differently to public and private vehicle and to different levels of vehicle autonomous capabilities [SAE J3016].

14.2 Example of VMS reference configuration

M0-M5 configurations are example capabilities and use cases.

M0 and M1 are for after market solutions while M2 to M5 are embedded solutions with increasing capabilities.

14.2.1 M0 configuration

- ✓ Aftermarket VMS. Fitted after buying the car.
- ✓ Not connected to vehicle network.
- ✓ Brought-in connectivity. Mobile device connected to car through Bluetooth/USB
- ✓ Connected to vehicle only for the operating power requirements

Entertainment Capability	Social usage capability	Office use capability	Game play capability
1. Music playback: Local music/CD-AUX-SD-USB 2. Radio: FM-AM	1. Text social: Support for SMS. Received SMS displayed in VMS display using BT protocol feature, brought-in connectivity. 2. Communication social: Only single Bluetooth phones are supported, and only one person can be connected to at a time. Restricted by design.	Hands-free-phone thru the brought-in connectivity.	No. Restricted by design.

14.2.2 M1 configuration

Provides the following capabilities above M0:

- ✓ Provides advance mobile connectivity solutions such as CarPlay, screen mirroring
- ✓ Interactive applications and control sharing between VMS and brought-in connectivity.
- ✓ Connected to vehicle for power requirements and game control requirements

Entertainment Capability	Social usage capability	Office use capability	Game play capability
1. Music playback: Local music/CD-AUX-SD-USB 2. Radio: FM-AM 3. Video playback: Local video 4. Support mobile connectivity solutions such as CarLife/CarPlay 5. Screen casting.	1. Text and pictures social: Support for SMS and MMS. Received SMS and MMS displayed in VMS display using BT protocol feature 2. Communication social: Support for multi-way Bluetooth access and single-way telephone access dial-out, car can be connected at the same time, no need to reconnect	1. Hands-free-phone thru the brought-in connectivity. 2. Calendar events sync from mobile phone to VMS (viewable from car)	Interactive gaming

14.2.3 M2 configuration

- ✓ Connected to vehicle network
- ✓ Hybrid connectivity. Vehicle has its own built-in connectivity to access APPs and other services also possible to connect mobile phone connectivity thru Bluetooth/USB or other solutions
- ✓ Connectivity through 2G/3G/4G/5G
- ✓ Service continuity between different use places
- ✓ Voice interaction controls

Entertainment Capability	Social usage capability	Office use capability	Game play capability
<ol style="list-style-type: none"> 1. Music playback: Local music/CD-AUX-SD-USB 2. Radio: FM-AM/Online Internet radio 3. Video playback: Local video 4. Support for mobile connectivity solutions such as CarLife/CarPlay 5. Screen casting 6. Voice interaction: Specific instruction voice interaction 	<ol style="list-style-type: none"> 1. Text, pictures and voice social: Support for SMS, MMS and social media connectivity 2. Support for multi-channel Bluetooth access and headphone bone conduction calls (single person support) 3. Support for simple team travel: location real-time sharing 4. Continuity in service between different use places viz home/office/car using Wi-Fi, APP connectivity 	<ol style="list-style-type: none"> 1. Support multi-person car conference call 2. Calendar events sync from phone to car (viewable from car) 3. Nomadic devices connectivity. 4. Continuity in service between different use places viz home/office/car using Wi-Fi, APP connectivity 	Interactive gaming

14.2.4 M3 configuration

- ✓ Connected to vehicle network
- ✓ Hybrid connectivity. Vehicle has its own built-in connectivity to access APPs and other services possible to connect mobile phone connectivity thru Bluetooth/USB or other solutions
- ✓ Single display
- ✓ Continuity in service between different use places viz home/office/car using Wi-Fi, APP connectivity
- ✓ Advance voice control
- ✓ Shared mobility applications capabilities
- ✓ Build-in game applications capabilities
- ✓ Basic security capabilities

Entertainment Capability	Social usage capability	Office use capability	Game play capability
<ol style="list-style-type: none"> 1. Music playback: Local music/CD-AUX-SD-USB 2. Radio: FM-AM/DAB/Online Internet radio 3. Video playback: Local video 4. Support mobile connectivity solutions such as CarLife / CarPlay 5. Voice interaction: Smart voice interaction through Internet services 6. AR enhanced display APP on Centre Screen 7. Simple multi-screen interaction: Display entertainment function information on the instrument screen/HUD/air conditioning control screen, which can be easily interacted by protocol 8. Anthropomorphic interactions: Emotional interaction robots (e.g. NOMI, Small-scale car robots) 	<ol style="list-style-type: none"> 1. In-car social support is in the following formats: Text, pictures, voices, and small video social (e.g. Shake Tiktok) 2. Communication social: Support for Bluetooth phones and seat bone conduction calls (headphone-free, single-way calls) / headphone bone conduction calls (supporting single person) 3. Support complex group travel: positioning and navigation route sharing 	<ol style="list-style-type: none"> 1. Support for on-board video conference calls (support for live screen; no support for file picture sharing), support for voice memos, voice memos to text and memos to share to mail 2. Two-way synchronization of mobile phones and car for calendar events (not only can be seen on board, but can also be edited) 3. Support event trigger navigation 4. The computer can use the computer Wi-Fi internet, the computer 	<ol style="list-style-type: none"> 1. Mini-games (question-and-answer games based on voice interaction) 2. The on-board version of the online competitive game is supported when parking; 3. Support for action adventure game machine version when parking

		edited mail can be sent through the car network	
--	--	---	--

14.2.5 M4 configuration

- ✓ Connected to vehicle network
- ✓ Hybrid connectivity. Vehicle has its own built-in connectivity to access APPs and other services possible to connect mobile phone connectivity thru Bluetooth/USB or other solutions
- ✓ Higher display capability
- ✓ Multi screen interaction capability
- ✓ Continuity in service between different use places viz home/office/car using Wi-Fi, APP connectivity
- ✓ Occupant health and comfort monitoring capability
- ✓ Advance HMI capability
- ✓ Advanced integrated control capability for game play
- ✓ Shared mobility and connected cars applications capabilities
- ✓ PII protection and security capability

Entertainment Functions	Social use Functions	Office use Functions	Game play Functions
<ol style="list-style-type: none"> 1. Music playback: Local music/CD-AUX-SD-USB 2. Radio: FM-AM/DAB/SDARS/Online Internet radio 3. Video playback: Local video 4. Support mobile connectivity solutions such as CarLife/CarPlay 5. Voice interaction: Smart voice interaction to Get Through the Internet Service Ecology 6. Simple multi-screen interaction: Display entertainment function information on the instrument screen/HUD/air conditioning control screen, which can be easily interacted by protocol 7. Multimedia entertainment information system platform and rich content resources with the fusion of multi-satellite broadcasting network and terrestrial cellular networks 8. AR Enhanced display Application on HUD and Centre Screen 	<ol style="list-style-type: none"> 1. Pre-install edgy social software for the car, and the in-car social support is in the following formats: Text, pictures, voice, small video social (e.g. Sonic Tiktok) 2. Communication social: Support for Bluetooth phones and seat bone conduction calls (headphone-free, dual-way calls supported) and headphone bone conduction calls (single-supporting) 3. Support complex team travel: positioning, navigation route sharing, support mobile bus route planning sharing 	<ol style="list-style-type: none"> 1. Support for on-board video conference calls (support for live screen, no support for file picture sharing), support for voice memos, voice memos to text and memos shared to mail/social software (e.g. WeChat) Back support for hand-written board recording MEMO 2. Calendar event mobile phone, car two-way synchronization (the car can not only be seen, but also edited) 3. The rear screen of the car system supports checking and editing mail; 4. Support handwriting/review/forward mail when parking 	<ol style="list-style-type: none"> 1. Co-driver or main driver parking can support small games based on gesture recognition, such as cutting fruit; 2. Racing games based on the steering wheel when parking 3. Mini games (question and answer games based on voice interaction) 4. Parking support: on-board version of online competitive games;

<p>9. Holographic projection display in specific areas of the vehicle, but only for display and not for interaction</p>			
---	--	--	--

14.2.6 M5 configuration

- ✓ Connected to vehicle network
- ✓ Hybrid connectivity. Vehicle has its own built-in connectivity to access APPs and other services also possible to connect mobile phone connectivity thru Bluetooth/USB or other solutions
- ✓ Satellite media reception capability
- ✓ LCD screen support for hetero-shaped screen/OLED flexible screen/all-in-one screen
- ✓ Advanced multi display interaction and HMI capabilities such as gesture recognition, voice capability
- ✓ Continuity in service between different use places viz home/office/car using Wi-Fi, APP connectivity
- ✓ Advanced Audio, video formats playing capabilities
- ✓ Advanced connected car, shared mobility features
- ✓ PII protection and security capability(such as Driver monitoring cameras)

Entertainment Functions	Social use Functions	Office use Functions	Game play Functions
<p>1. Music playback: Local music/CD-AUX-SD-USB 2. Radio: FM-AM/Online Internet radio 3. Video playback: Local video 4. Support mobile connectivity solutions such as CarLife/ CarPlay 5. Voice interaction: Smart voice interaction to Get Through the Internet Service Ecology 6. Simple multi-screen interaction: Display entertainment function information on the instrument</p>	<p>1. Pre-installed customized social software for the car and in-car social support is in the following formats: text, pictures, voices, small video social (e.g., Tiktok) and Live social, interactive games social 2. Communication social: Support for Bluetooth phones (headphone-free,</p>	<p>1. Support for on-board video conferencing (supports real-time screens, does not support file picture sharing), voice memos, voice memos, text and voice memos, and memos shared to mail/social software (e.g. WeChat), Support for tablet recording memo 2. Calendar event phone, two-way synchronization (car cannot only see, but also can be edited)</p>	<p>1. Co-driver or main driver parking can support small games based on gesture recognition, such as cutting fruit; 2. Racing games based on the steering wheel when parking 3. Mini games (question and answer games based on voice interaction)</p>

<p>screen/HUD/air conditioning control screen, which can be easily interacted by protocol</p> <p>7. Multimedia entertainment information system platform and rich content resources with the fusion of satellite broadcasting networks multi-satellite and terrestrial cellular networks</p> <p>8. AR enhanced display can be applied on any screen, including HUD and Centre Screen</p> <p>9. Customized holographic projection, users can display the contents of the screen in multiple areas of the car, not only to support display, but also to support interaction, similar to virtual assistant</p> <p>10. Driver video recording, Driver Monitoring System, Around view Monitoring Cameras</p> <p>11. Gesture Recognition capability</p> <p>12. Voice Biometric identity</p>	<p>multiple-way calls, unheard-of content between different passengers) and headphone conduction calls (single support)</p> <p>3. Support complex team travel: positioning, navigation screen sharing, support mobile bus route planning sharing, route 3D visualization</p>	<p>3. The rear windshield supports the inspection and editing of mail;</p> <p>4. Support for handwriting/review/forwarding messages when parking</p> <p>5. Front row supports on-board custom office software operations based on holographic projection/gesture recognition/eye control (in conjunction with hardware)</p>	<p>4. Parking support: on-board version of online competitive games;</p> <p>5. Games that support holographic projection and holographic interaction</p>
---	--	---	--

15 Vehicle domain service (VDS)

15.1 General

Autonomous vehicles and high intelligent driver support systems will digitize the whole information around the vehicle. Plenty of data from sensors or lidar, meta data provided by image recognition of motion pictures taken by cameras installed outside the vehicle are integrated with communication data from neighbouring traffic participants around the vehicle in order to generate local map information surrounding the vehicle.

[ISO 23239], vehicle domain service will introduce such an information and recognition platform applied to autonomous vehicles and intelligent driver support systems. The basic definition of vehicle domain service is the service application provided by the vehicle server which is implemented in a vehicle. It will be applied in the area surrounding the vehicle (named as vehicle domain), which is the area identified by service connectivity between the domain master vehicle (server) and the domain actors (e.g. other vehicles, network infrastructure sensors, other participants), equipped (or not) with VDS. In this context, a basic service will be provided through communication exchanges between the master vehicle and the domain actors.

A basic vehicle domain service (VDS) scenario consists of one master vehicle and one domain actor; this is the most simple structure with minimum elements. A typical and valuable service consists of the capability of generating a high definition map including traffic-moving bodies surrounding the master vehicle with driving speed. This is known as 'vehicle domain dynamic map service', the most important use case of VDS.

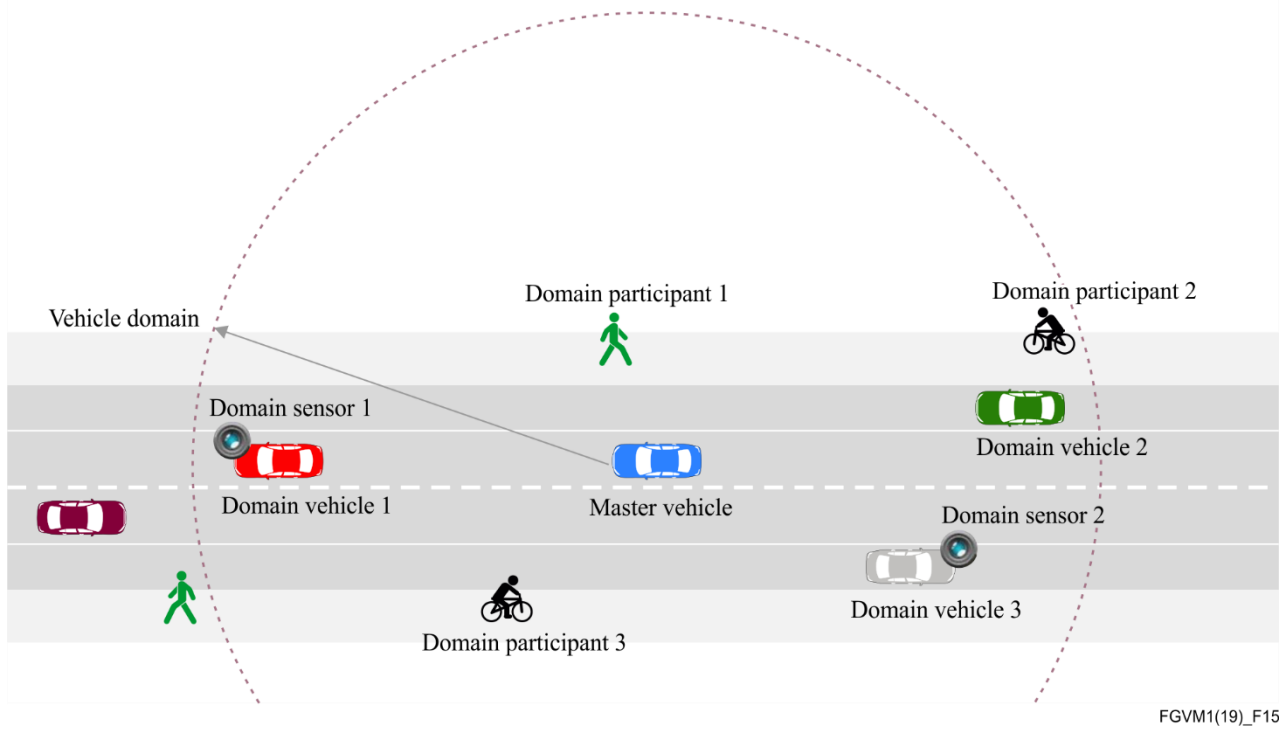

Figure 16 – Vehicle domain dynamic map service

This use case is carefully distinguished from the typical use case definition of vehicle multimedia service defined in this document. Figure 16 of vehicle domain dynamic map VDDMS shows the different actors and use case, intended to use VDS. VDDMS includes multiple inputs from outside sensors and cameras plus other information provided by communication networks.

15.2 Vehicle domain service on vehicle multimedia service

A typical vehicle domain dynamic map service collects sensor and communication data provided by sensors outside a vehicle and communication network. Information media, such as sensors and network channels could be shared between VDS and VMS, but some of the dedicated information for VDS will be sent directly and only to the VDS, as illustrated in Fig. 17. VDDMS, vehicle domain dynamic map service will generate dynamic traffic information based on high definition map around the master vehicle and send it to the vehicle human machine interactive interface. Desired language translation should be provided by VDS and VMS as a unique interface, as required by the driver.

15.2.1 Use case – VDS on VMS

Figure 17 shows the typical input/output model of the vehicle domain service (VDS) integrated with that of the vehicle multimedia service (VMS). The basic reference model of VMS is defined in Figure 2 of this document.

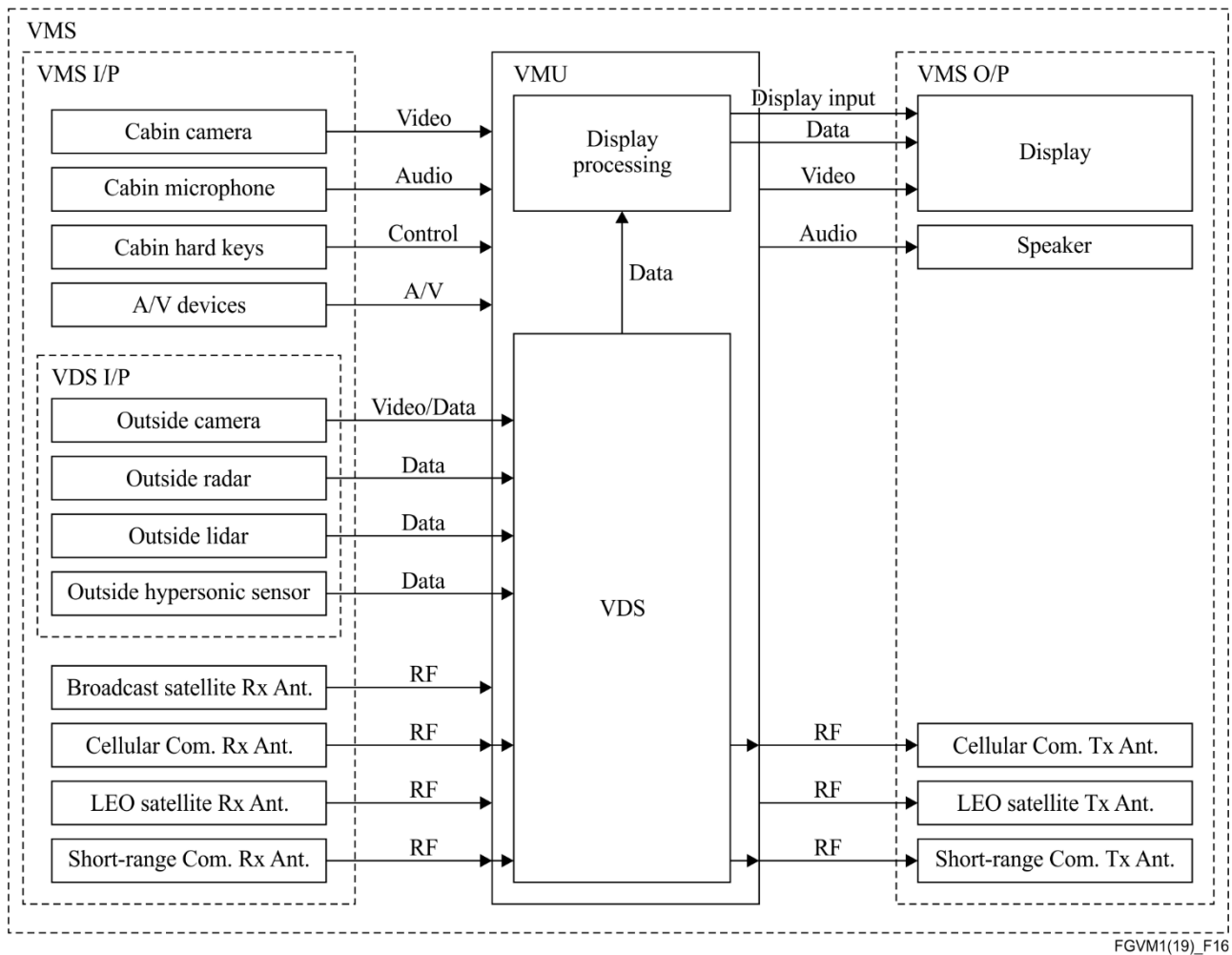

FGVM1(19)_F16

Figure 17 – A reference model for data input/output of the VDS on VMS

VDS is one of the network services provided by the master vehicle, so basic inputs/outputs of VDS are network communication channels such as cellular or short-range networks. VDDMS will generate high definition maps from VDS specific signals of lidar, radar and sensors via recognized meta data objects. Motion pictures provided by vehicle outside cameras will also generate meta data of foreign objects around the master vehicle. Those meta data will be integrated as high definition map in VDS functional module.

Network communication channels connected to VDS will be shared with VMS in order to exchange other kinds of communication network services. Motion pictures acquired by cameras outside the vehicle are also shared similar to the vehicle outside/surrounding monitor service of VMS.

VDDMS will have some user interactive functions, such as traffic information monitor, warning messages about dangerous traffic objects and interactive messaging services between the driver in the master vehicle and domain vehicles and other participants of surrounding traffic. The driver condition, which could be monitored by the vehicle cabin camera, could be an optional VDS services. These interactive human machine interface (HMI) services with the driver will be basically provided by VMS and VDS that will utilize these VMS service connecting to VMS.

As explained in clause 6, Figure 2 of the VMS input/output reference model, the VDS function indicated in Figure 16 never shows a single physical unit. It is located in the VMS function in the figure, but its function is independently implemented from VMS functions. VDS shares some inputs/outputs with VMS and uses the interactive HMI service of the VMS. Therefore, this document includes implementation of a VDS function along with the multimedia network platform of VMS.

15.2.2 Requirements – VDS use case in relation with VMS

This clause will provide use case requirements about VDS, focusing VDDMS on VMS. Relevant use case definition and detailed explanation are given in clause 15.2.

VVR1: The VMS may be designed to support VDS function.

VVR2: If the VDS is implemented with VMS, network communication channels and connection shall be accessible to both the VMS and VDS.

NOTE 1 – VMS and VDS will share only lower layers of communication channel.

VVR3: If the VDS is implemented with VMS, raw data from external cameras of the vehicle and sensors shall be accessible by VMS and VDS independently.

NOTE 2 – Low level motion picture data input to VDS will be treated by image recognition engine to convert lighter Meta data of traffic objects.

VVR4: The VMS may provide interactive HMI with driver to the VDS, especially to VDDMS.

VVR5: If VDS is implemented with VMS, the VMS and VDS shall keep real time quality between interactive HMI and real surrounding traffic condition.

NOTE 3 – It is important for VMS and VDS to give good synchronization between their displayed contents of VDDMS and real traffic condition around the vehicle.

VVR6: If VDS is implemented with VMS, good synchronization between VDDMS graphic contents displayed by VMS and surrounding real traffic condition shall be defined as delay time between them.

NOTE 4 – The criteria of delay time depends on other requirements.

16. Matching of described use cases with driving levels

The following table matches use cases and services that have been defined within the focus group with the SAE driving levels. All activities that are mentioned in the table should be considered for a driving vehicle. When the vehicle parks or stands still, all services are available for the driver as well as for the passengers. Excluded in this case is a standing vehicle at traffic lights or other traffic signs as in this case the vehicle and the driver are still considered as active traffic participants similar to a driving car.

Within the driving levels, a distinction on what drivers (D) and passengers (P) are allowed to do in the framework of these use cases and services is taken into consideration.

Use Cases	SAE LEVEL 0		SAE LEVEL 1		SAE LEVEL 2		SAE LEVEL 3		SAE LEVEL 4		SAE LEVEL 5	
	D	P	D	P	D	P	D	P	D	P	D	P
7.3.1 Multimedia Content		✓		✓		✓	(✓)	✓	✓	✓	✓	✓
7.4.1/2 Nomadic Device Connectivity	✓	✓	✓	✓	✓	✓	✓	✓	✓	✓	✓	✓
7.4.4. Comfort and Well-being on Board	✓	✓	✓	✓	✓	✓	✓	✓	✓	✓	✓	✓
7.4.5. On-demand functions private vehicle	✓	✓	✓	✓	✓	✓	✓	✓	✓	✓	✓	✓
7.5.1 Continuity of Service- Video streaming		✓		✓		✓	(✓)	✓	✓	✓	✓	✓
7.5.2 Cloud based Services		✓		✓		✓	(✓)	✓	✓	✓	✓	✓
8.1.2.1/2 Voice Recognition Session	✓	✓	✓	✓	✓	✓	✓	✓	✓	✓	✓	✓
8.3 Gaze Tracking	✓	✓	✓	✓	✓	✓	✓	✓	✓	✓	✓	✓
9.3 Private Vehicle – Single User		✓		✓		✓	(✓)	✓	✓	✓	✓	✓
9.4 Long distance shared vehicle		✓		✓		✓	(✓)	✓	✓	✓	✓	✓
9.5 - Public Transport shared vehicle multi users		✓		✓		✓		✓		✓		✓
10.2.1 VMS with Flexible EMM		✓		✓		✓	(✓)	✓	✓	✓	✓	✓
10.2.2 VMS with Extended EMM		✓		✓		✓	(✓)	✓	✓	✓	✓	✓
11.2 Privilege and Account Management	(✓)	✓	(✓)	✓	(✓)	✓	(✓)	✓	✓	✓	✓	✓
11.3 Payment Services Shared Vehicles	(✓)	✓	(✓)	✓	(✓)	✓	(✓)	✓	✓	✓	✓	✓

✓ = Allowed

(✓) = Partly allowed (in autonomous driving mode or when it is an audio application only, or according to details that are defined in the respective use-cases). Local or global regulations apply.

Figure 18 – Matching of specific multimedia use cases with SAE driving levels

Annex A

Vehicle domain service requirements

NOTE – The VDS requirements proposed in this section are similar to the requirement in [ISO 23239] (not yet finalized at the time this Technical Report was published), and will be replaced by a reference once [ISO 23239] is published.

A.1 Background

Autonomous vehicles and high intelligent driver support system will digitize the entire information related to the vehicle. A lot of data from sensors, lidar and image recognition of motion pictures taken by cameras installed in a vehicle are integrated with communication data from neighbouring traffic participants around the vehicle to generate local map information surrounding the vehicle.

[ISO 23239], vehicle domain service will introduce such an information and recognition platform applied to autonomous vehicles and intelligent driver support systems. It will gather and integrate multimedia sensor and communication data to generate driving status of map information. It will be shared with neighbouring traffic participants and reported to central integrated vehicle dynamic map server.

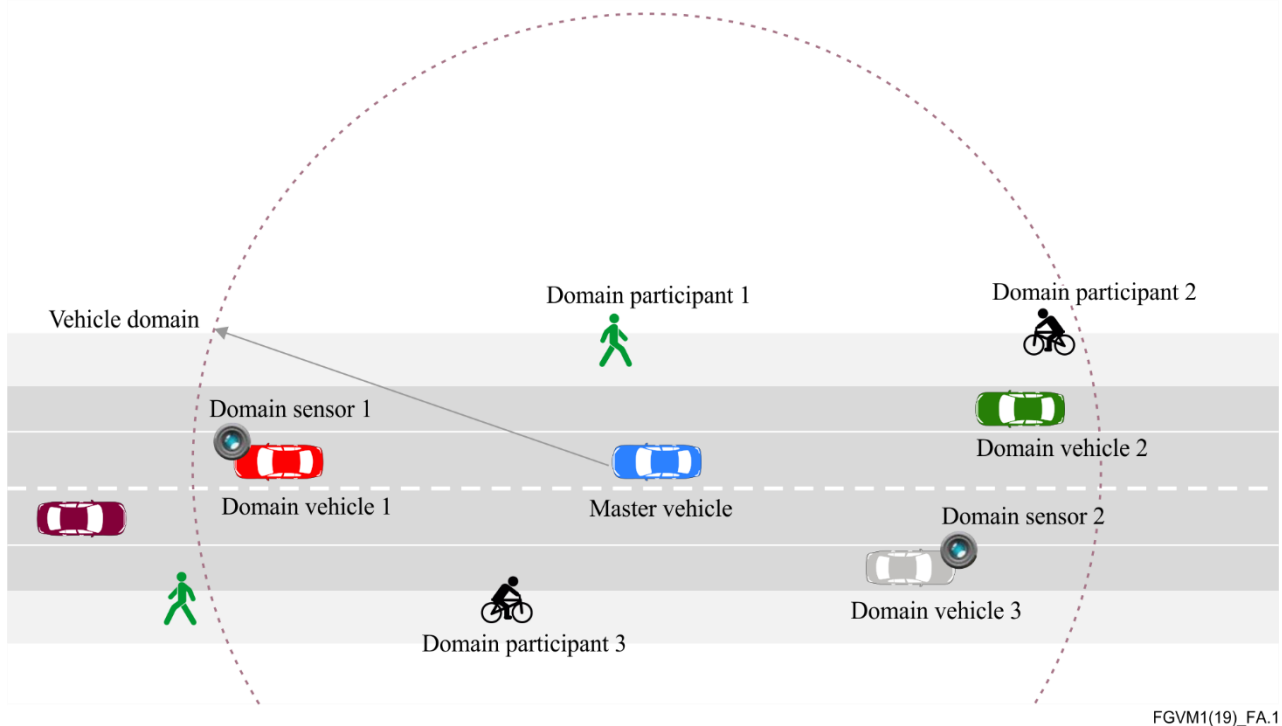

Figure A.1 – Vehicle domain dynamic map

In order to collect the necessary information, the vehicle with VDS will use communication with domain actors. There are various types of domain actors, but their communication interfaces are unified.

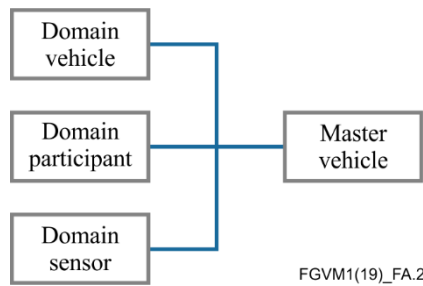

Figure A.2 – Unified communication interface of VDS

In order to provide secure and safe communication, necessary schema will be applied.

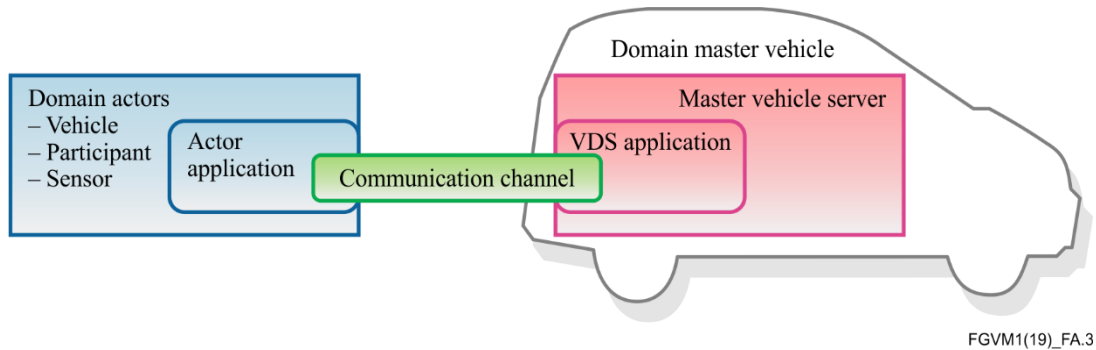

Figure A.3 – Communication channel of VDS

In order to utilize the generated map efficiently, it is necessary that it is reported to neighbouring vehicles and data collecting server of vehicle dynamic map and shared with other domain actors.

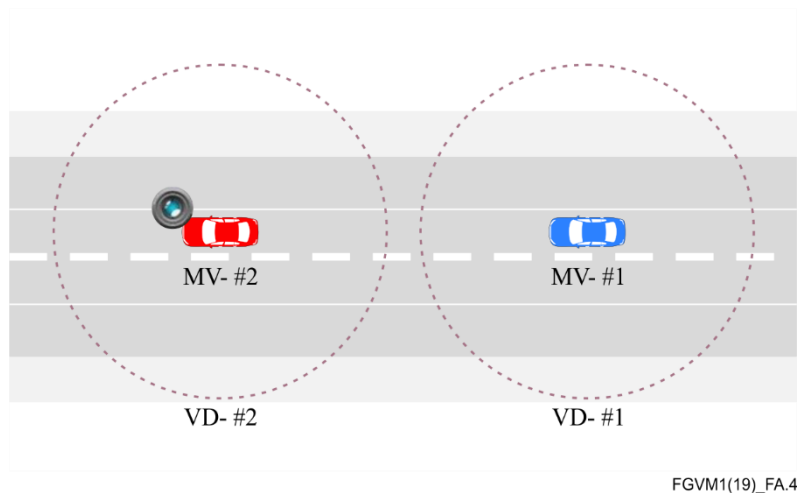

Figure A.4 – Reporting & sharing of VDDM

A.2 Proposed requirements

If the vehicle is implemented with vehicle domain dynamic map (VDDM), the following requirements shall be applied.

VDDM-1: If the vehicle uses VDDM, it shall consist of dynamic traffic information and static road situation surrounding the vehicle.

VDDM-2: The static road situation part of VDDM shall consist of the temporary situation part and the permanent status part.

NOTE 1 – The permanent status part of VDDM consists of detailed features and figures of road, similar structure and properties to those of high definition map.

VDDM-3: The dynamic traffic information part of VDDM shall consist of traffic participants part and traffic control status part.

NOTE 2 – Traffic participants includes vehicles, bikes, walkers and all other traffic movable bodies.

NOTE 3 – Traffic control status includes signals, priority lane, access control and all other controlled traffic status on the road.

VDDM-4: If the vehicle generates VDDM, the vehicle shall collect the necessary information by communicating with surrounding domain actors and scanning result of equipped sensors.

NOTE 4 – Domain actors are traffic participants, such as vehicles, bikes, walkers and other movable bodies on the road.

VDDM-5: If the vehicle generates VDDM, the vehicle shall collect the necessary information by communication from both domain actors and scanning results from domain sensors.

NOTE 5 – Domain sensor is one of the domain actors such as the vehicle equipped with sensors scanning surrounding traffic situation, which reports sensor output.

VDDM-6: If the vehicle generates VDDM, the static road situation part shall be generated from sensor output or a combination of sensor output and downloaded high definition map.

NOTE 6 – High definition map only defines the permanent status of the road.

NOTE 7 – The temporary situation part of static road situation is given by sensor output.

VDDM-7: If the vehicle is applied with VDDM, the master vehicle shall report the generated VDDM to other domain actors and VDDM collecting servers.

NOTE 8 – The format of the report and its communication interfaces are unified between domain actors and data collecting servers.

NOTE 9 – Sending and receiving of the VDDM report is performed in aligning to VDS communication requirements.

NOTE 10 – The format of the report may contain multiple sensor data which can be sent in a compressed format to reduce bandwidth consumption. ISO/IEC 23090-9 compresses point cloud scene/maps.

VDDM-8: If the vehicle is applied with VDDM, the master vehicle shall share the received VDDM report and utilize it as the basis of the next generation of VDDM.

NOTE 11 – Details of sharing method are addressed to ISO 23239 series documents.

[ISO 23239] is drafted in ISO TC 22/SC 31/WG 8. It will be harmonized with ITU-T SG16.

If the vehicle communicates with domain actors for applying vehicle domain service (VDS), the following requirements shall be applied.

VDS-1: If the vehicle uses VDS, it shall communicate with surrounding domain actors of various types in order to collect information.

NOTE 12 – Basic types of domain actors are domain vehicle, domain participant and domain sensor.

NOTE 13 – Domain vehicle includes various types of road vehicles such as consumer (driving) vehicle, taxi, sharing car, logistics trucks, public bus and tram.

VDS-2: The communication interface such as messages, protocols, data link layer and physical layer shall be unified for the various types of domain actors.

For the minimum treatment to integrate a lot of responses from various actors, unified message format definition and sequences are important features.

NOTE 14 – Different data container is required for each type of actor in order to treat various responses with the same message format.

VDS-3: If the vehicle uses VDS, the appropriate security at the right level shall be applied on the communication channel among VDS.

NOTE 15 – Part of the latest security specifications used in Internet communication will be enough for VDS communication.

VDS-4: Privacy relevant and personal traceable information shall be contained in VDS messages.

NOTE 16 – Personal private information might be managed in totally separate methods and location from VDS in order to respond to supervised requests such as government or police level.
