



Source: Document 8A/TEMP/110(Rev.1)

Working Party 8A

DRAFT NEW REPORT ITU-R M.[PPDR]

Radiocommunication objectives and requirements for Public Protection and Disaster Relief (PPDR)

Scope

The purpose of the Report is to define the PPDR objectives and requirements for the implementation of future advanced solutions to satisfy the operational needs of PPDR organizations around the year 2010. Specifically, it identifies objectives, applications, requirements, a methodology for spectrum calculations, spectrum requirements and solutions for interoperability.

This report has been developed in preparation for WRC-03 agenda item 1.3:

"to consider identification of globally/regionally harmonized bands, to the extent practicable, for the implementation of future advanced solutions to meet the needs of public protection agencies, including those dealing with emergency situations and disaster relief, and to make regulatory provisions, as necessary, taking into account Resolution 645 (WRC-2000)."

Resolution **645 (WRC-2000)** invited the ITU-R to *"study, as a matter of urgency, identification of frequency bands that could be used on a global/regional basis by administrations intending to implement future solutions for public protection agencies and organizations, including those dealing with emergency situations and disaster relief"* and *"to study, as a matter of urgency, regulatory provisions necessary for identifying globally/regionally harmonized frequency bands for such purposes"*. Resolution **645** also invited the ITU-R to *"... conduct studies for the development of a resolution identifying the technical and operational basis for global cross-border circulation of radiocommunication equipment in emergency and disaster relief situations"*. Draft New Recommendation ITU-R M.[DR.RCIRC] (Doc. 8/73) provides additional guidance on this element.

Background

Radiocommunications have become extremely important to Public Protection and Disaster Relief (PPDR) organizations to the extent that PPDR communications are highly dependent upon it. At times, radiocommunication is the only form of communications available.

In order to provide effective communications, PPDR agencies and organizations have a set of objectives and requirements that include interoperability, reliability, functionality, security in operations and fast call set-up¹ in each area of operation. Considering that the radiocommunication needs of PPDR agencies and organizations are growing, future advanced solutions used by PPDR will require higher data rates, along with video and multimedia capability.

This Report forms part of the process of specifying these objectives and the requirements of PPDR organizations to meet their future needs. PPDR organizations will operate their communications in a complex environment, which requires the recognition of the following factors:

- a) the involvement of a number of interests (such as governments, service providers, manufacturers);
- b) the changing regulatory framework for those involved in supplying systems supporting PPDR;
- c) that PPDR applications may be narrowband, wideband or broadband, or a mixture of these;
- d) the need for interoperability and interworking between networks;
- e) the need for high levels of security;
- f) the needs of developing countries;
- g) the ITU-D Handbook on Disaster Communications;
- h) the needs of countries, particularly for developing countries, for low-cost communications equipment for public protection and disaster relief agencies and organizations;
- i) that the 1998 Intergovernmental Conference on Emergency Telecommunications (ICET-98), with the participation of 76 countries and various intergovernmental and non-governmental organizations, adopted the Tampere Convention on the Provision of Telecommunication Resources for Disaster Mitigation and Relief Operations. In 1998, thirty-three States signed this comprehensive Convention that also contains an article dealing with the removal of regulatory barriers;
- j) that the *Working Group on Emergency Telecommunications* (WGET), which is also the *Reference Group on Telecommunications* (RGT) of the *Inter-Agency Standing Committee* (IASC) on humanitarian affairs has adopted frequencies in the VHF and UHF bands allocated to the land mobile service for inter-agency coordination of relief operations and safety and security communications in international humanitarian assistance as listed in Annex 3 to this document;
- k) that many disaster relief organizations require independence to fulfill their humanitarian mandate by maintaining their operational autonomy while fully respecting the laws of the countries in which they operate;
- l) that in times of disasters, when most terrestrial based networks may be destroyed or impaired, amateurs, satellite and other non-ground based networks may be able to provide communications services to assist in public protection and disaster relief efforts;
- m) that systems operating within various radiocommunication services, including mobile, fixed, mobile satellite, fixed satellite and/or amateur, could support both current and future advanced PPDR applications;
- n) that in some countries, national regulations and/or legislation may affect the ability of PPDR organizations to use commercial wireless systems or networks;

¹ Fast call set-up indicates reducing the response time to access the particular network.

- o) that in some countries, commercial wireless systems currently offer and will likely continue to support PPDR applications;
- p) that there is potential for new technologies such as IMT-2000 systems and beyond, and Intelligent Transportation Systems (ITS) which may support or supplement advanced PPDR applications and that such complementary use would be in response to market demands.

Harmonization of spectrum

Significant amounts of spectrum are already in use in various bands in various countries for narrowband PPDR applications, however, it should be noted that sufficient spectrum capacity will be required to accommodate future operational needs including narrowband, wideband and broadband applications. Experience has shown that spectrum that is harmonized has benefits that include economic benefits, the development of compatible networks and effective services and the promotion of interoperability of equipment internationally and nationally for those agencies that require national and cross-border cooperation with other PPDR agencies and organizations. Specifically, some potential benefits are as follows:

- economies of scale in the manufacturing of equipment;
- competitive market for equipment procurement;
- increased spectrum efficiency;
- stability in band planning, that is, evolving to globally/regionally harmonized spectrum arrangements may assist in more efficient planning of land mobile spectrum; and
- increased effective response to disaster relief.

When considering appropriate frequencies for PPDR, it should be recognized that the propagation characteristics of lower frequencies allow them to travel farther than higher frequencies, making low frequency systems potentially less costly to deploy in rural areas. Lower frequencies are also sometimes preferred in urban settings due to their superior building penetration. However, these lower frequencies have become saturated over time and to prevent overcrowding some administrations now use more than one frequency band in different parts of the radio spectrum.

The more bands that may be identified with different propagation characteristics the more difficult it becomes to benefit from economies of scale. Therefore, a balance needs to be struck between the number and location of the bands identified.

Aspects of frequency bands for PPDR

Based upon an ITU-R survey of PPDR communications conducted in the 2000-2003 study period from over 40 ITU members and international organizations and consequent considerations, the following comments should be noted:

- a) There is little uniformity in regard to frequency bands that are used for PPDR in different countries.
- b) While in most countries the bands used for public protection are the same as those used for disaster relief, in some countries separate bands are used.
- c) Many administrations have designated one or more frequency bands for narrowband PPDR operations. It should be noted that only particular sub-bands of the frequency ranges or parts thereof listed below are utilized in an exclusive manner for PPDR radiocommunications: 3-30, 68-88, 138-144, 148-174, 380-400 MHz (including CEPT designation of 380-385/390-395 MHz), 400-430, 440-470, 764-776, 794-806, and 806-869 MHz (including CITELE designation of 821-824/866-869 MHz). One administration has designated PPDR spectrum for wideband and broadband applications.

- d) Some administrations in Region 3 are using or plan to use or have identified parts of the frequency bands 68-88 MHz, 138-144 MHz, 148-174 MHz, 380-399.9 MHz, 406.1-430 MHz and 440-502 MHz, 746-806 MHz, 806-824 MHz and 851-869 MHz for PPDR applications. Some administrations in Region 3 are also using the bands 380-399.9 MHz, 746-806 MHz and 806-824 MHz paired with 851-869 MHz for Government communications.

The bands which are listed in c) and d) above and other potential candidate bands are discussed in detail in the CPM-02 Report (section 2.1.2.6) together with their advantages and disadvantages and are listed in Annex 2.1-1 of the CPM-02 Report.

Summary

Based on the studies undertaken in ITU-R on PPDR, this report focuses on the numerous radiocommunication objectives and requirements that may be required to support future advanced solutions for PPDR applications. The following areas of interest were generated during the process of developing this report:

- Annex 1 Radiocommunication Objectives for Public Protection and Disaster Relief
- Annex 2 Radiocommunication Requirements for Public Protection and Disaster Relief
- Annex 3 Narrowband Frequencies for Inter-Agency Coordination and Safety and Security Communications in International Humanitarian Assistance Presently in Use
- Annex 4 Spectrum Requirements for Public Protection and Disaster Relief
- Annex 5 Existing and Emerging Solutions to Support Interoperability for Public Protection and Disaster Relief

Annex 1

Radiocommunication objectives for Public Protection and Disaster Relief (PPDR)

1 General objectives

Public Protection and Disaster Relief (PPDR) radiocommunication systems aim to achieve the following general objectives:

- a) to provide radiocommunications that are vital to the achievement of:
 - i) the maintenance of law and order;
 - ii) response to emergency situations and protection of life and property;
 - iii) response to disaster relief situations;
- b) to provide the services as identified above in a) over a wide range of geographic coverage areas, including urban, suburban, rural and remote environments;
- c) to aid the provision of future advanced solutions requiring high data rates, video and multimedia used by PPDR agencies and organizations;
- d) to support interoperability and interworking between networks, both nationally and for cross-border operation, in emergency and disaster relief situations;
- e) to allow international operation and roaming of mobile and portable units;
- f) to make efficient and economical use of the radio spectrum, consistent with providing services at an acceptable cost;
- g) to accommodate a variety of mobile terminals from those which are small enough to be carried on ones person to those which are mounted on vehicles;
- h) to encourage the cooperation between countries for the provision of effective and appropriate humanitarian assistance during disaster relief situations;
- i) to make available PPDR radiocommunications at reasonable costs in all markets;
- j) to support the needs of developing countries, including the provision for low-cost solutions for PPDR agencies and organizations.

2 Technical objectives

Systems for PPDR aim to achieve the following technical objectives:

- a) to support the integration of voice, data, and image communication;
- b) to provide additional level(s) of security associated with the type of information carried over the communication channels associated with the various PPDR applications and operations;
- c) to support equipment that operates in extreme and diverse operational conditions (rough road, dust, extreme temperature, etc.);
- d) to accommodate the use of repeaters for covering long distances between terminals and base stations in rural and remote areas and also for intensive on-scene localized areas;
- e) to provide fast call set-up², one touch broadcasting and group call features.

² Fast call set-up indicates reducing the response time to access the particular network.

3 Operational objectives

Systems for PPDR aim to achieve operational objectives, including the following:

- a) to provide security including end-to-end encryption, terminals/network authentication;
- b) to enable communications management to be controlled by PPDR agencies and organizations such as instant/dynamic reconfiguration change, set-up talk groups, guaranteed access including priority and pre-emption calls, groups or general calls, spectrum resource availability for multiple PPDR agencies and organizations, coordination and rerouting;
- c) to provide communications through the system/network and/or independent of the network such as Direct Mode Operation (DMO), simplex radio and push-to-talk;
- d) to provide customized and reliable coverage especially for indoor areas such as underground and inaccessible areas. To also allow for the extension of cell size or capacity in rural and remote areas or under severe conditions during emergency and disaster situations;
- e) to provide full service continuity through measures such as redundancy for emergency operations, prompt capacity increase to survive partial loss of infrastructure crucial to effective mission compliance and the safety and security of PPDR personnel;
- f) to provide high quality of service including instant call set-up and instant push-to-talk, resilience under extreme load, very high call set-up success rate, etc.
- g) to take account of various PPDR applications.

Annex 2

Radiocommunication requirements for Public Protection and Disaster Relief (PPDR)

1 Terminology

1.1 Public Protection and Disaster Relief (PPDR)

There are terminology differences between administrations and regions in the scope and specific meaning of PPDR. The following terms are appropriate for the purpose of discussing this issue:

Public Protection (PP) Radiocommunication: Radiocommunications used by responsible agencies and organizations dealing with maintenance of law and order, protection of life and property, and emergency situations.

Disaster Relief (DR) Radiocommunication: Radiocommunications used by agencies and organizations dealing with a serious disruption of the functioning of society, posing a significant, widespread threat to human life, health, property or the environment, whether caused by accident, nature or human activity, and whether developing suddenly or as a result of complex, long-term processes.

1.2 Applicability of voice, data, graphics and video to global/regional PPDR

As PPDR operations become more reliant on electronic databases and data processing, access to accurate and detailed information by staff in the field such as police, firefighters and medical emergency personnel is critical to improving the effectiveness of the staff in resolving emergency situations. This information is typically held in office based database systems and includes images, maps, architectural plans of buildings, and locations of hazardous materials systems.

In the other direction, the flow of information back from units in the field to operational control centres and specialist knowledge centres is equally important. Examples to note are the remote monitoring of patients and remote real-time video monitoring of civil emergency situations including the use of remote control robotic devices. Moreover, in disaster and emergency situations, critical decisions to be made by controlling authorities are often impacted by the quality and timeliness of the information received from the field.

These applications in general require higher bit-rate data communications than can be provided by current PPDR applications. The availability of future advanced solutions is expected to be of benefit to PPDR operations.

1.3 Consideration of advantages with future technologies

While voice communications will remain a critical component of PPDR operations, new data and video services will play a key role. For instance, PPDR agencies today use applications such as video for surveillance of crime scenes and of highways, to monitor and conduct damage assessment of wild land fire scenes from airborne platforms to provide real-time video back to emergency command centres. Also, there is a growing need for full motion video for other uses such as robotic devices in emergency situations. These types of future advanced solutions will be capable of providing local voice, video and data networks, thereby serving the needs of emergency personnel responding to an incident.

If these future technologies were implemented globally, it could reduce the cost of equipment, increase availability of equipment, increase potential for interoperability, may provide for a wider range of capabilities and reduce network infrastructure rollout time.

Introduction of these technologies may enable PPDR agencies and organizations to keep up with increasing demands but also may enable them to implement advanced voice, text, video and other intensive data applications and services designed to enhance service delivery. In this regard, it should be noted that any development or planning for the use of future technologies may require that consideration be given to spectrum aspects for PPDR applications.

If PPDR applications used IMT-2000 technology, it may be possible to use commercial IMT-2000 networks in regions where it was not cost-effective to deploy a dedicated network. IMT-2000 is intended for deployment in a wide range of environments, from rural to the densest urban areas. Commercial systems that are being deployed using IMT-2000 technologies may not meet all of the identified needs for PPDR. However, the use of these technologies and systems should be considered, particularly in terms of the potential associated cost savings and advanced features that they offer.

1.4 Narrowband, wideband, broadband

Communications supporting PPDR operations cover a range of radiocommunication services such as fixed, mobile, amateur and satellite. Typically, narrowband technologies are used for PPDR communications within the terrestrial mobile service, while wideband and broadband technologies are finding PPDR applications within all radiocommunication services.

There are some differences between administrations and regions in the scope and specific meaning of narrowband, wideband and broadband. However, the ITU-R considers the terms described in Sections 1.4.1, 1.4.2 and 1.4.3 appropriate for the purpose of discussing this issue:

1.4.1 Narrowband (NB)

To provide PPDR narrowband applications, the trend is to implement wide area networks including digital trunked radio networks providing digital voice and low speed data applications (e.g. pre-defined status messages, data transmissions of forms and messages, access to databases). ITU Report ITU-R M.2014 lists a number of technologies, with typical channel bandwidths up to 25 kHz, that are currently used to deliver narrowband PPDR applications. Some countries do not mandate specific technology, but promote the use of spectrum-efficient technology.

1.4.2 Wideband (WB)

It is expected that the wideband technologies will carry data rates of several hundred kilobits per second (e.g. in the range of 384-500 kbit/s). Since it is expected that networks and future technologies may require higher data rates, a whole new class of applications including: wireless transmission of large blocks of data, video and Internet protocol-based connections in mobile PPDR may be introduced.

The use of relatively high-speed data in commercial activities gives a wide base of technology availability and will therefore spur the development of specialist mobile data applications. Short message and e-mail are now being seen as a fundamental part of any communications control and command system and therefore could most likely be an integral part of any future PPDR capability.

A wideband wireless system may be able to reduce response times of accessing the Internet and other information databases directly from the scene of an incident or emergency. It is expected that this will initiate the development of a range of new and secure applications for PPDR organizations.

Systems for wideband applications to support PPDR are under development in various standards organizations. Many of these developments are referenced in ITU Reports ITU-R M.2014, ITU-R M.1457, and ITU-R M.1073 and ITU-R M.1221, with channel bandwidths dependent on the use of spectrally efficient technologies.

1.4.3 Broadband (BB)

Broadband technology could be seen as a natural evolutionary trend from wideband. Broadband applications enable an entirely new level of functionality with additional capacity to support higher speed data and higher resolution images. It should be noted that the demand for multimedia capabilities (several simultaneous wideband and/or broadband applications running in parallel) puts a huge demand with very high bit rates on a wireless system deployed in a localized area with intensive on-scene requirements (often referred to as "hot spot" areas) where PPDR personnel are operating.

Broadband applications could typically be tailored to service localized areas (e.g. 1 km² or less) providing voice, high-speed data, high quality digital real time video and multimedia (indicative data rates in range of 1-100 Mbit/s) with channel bandwidths dependent on the use of spectrally efficient technologies. Examples of possible applications include:

- 1) high-resolution video communications from wireless clip-on cameras to a vehicle-mounted laptop computer, used during traffic stops or responses to other incidents and video surveillance of security entry points such as airports with automatic detection based on reference images, hazardous material or other relevant parameters;
- 2) remote monitoring of patients and remote real-time video view of the single patient demanding up to 1 Mbit/s. The demand for capacity can easily be envisioned during the rescue operation following a major disaster. This may equate to a net hot spot capacity of over 100 Mbit/s.

Broadband systems may have inherent noise and interference tradeoffs with data rates and associated coverage. Depending on the technology deployed, a single broadband network may have different coverage areas in the range of a few metres up to hundreds of metres, providing a wide range in spectrum reuse capability. Collectively, the high data speeds and localized coverage area open up numerous new possibilities for PPDR applications (Tailored Area Networks, hot spot deployment and ad-hoc networks).

Finally, it should be noted that various standards organizations are beginning work on systems for broadband applications including Project MESA.

2 Radio operating environments for PPDR

Various radio operating environments are applicable to PPDR and are explained in this section. The purpose of further explaining distinct radio operating environments is to define scenarios that, from the radio perspective, may impose different requirements on the use of PPDR applications and their importance.

The identified PPDR scenarios could serve as the basis for identifying PPDR requirements and may complement the estimates for spectrum.

The scenarios include average day-to-day operations, large emergencies or public events and disasters. These have been identified since they are distinct in terms of the characteristics and may impose different requirements for PPDR communications.

2.1 Day-to-day operations

Day-to-day operations encompass the routine operations that PPDR agencies conduct within their jurisdiction. Typically, these operations are within national borders. Generally, most PP spectrum and infrastructure requirements are determined using this scenario with extra capacity to cover unspecified emergency events. For the most part day-to-day operations are minimal for DR. In Tables 2 and 3 of this Annex, day-to-day operations are referred to as PP (1).

2.2 Large emergency and/or public events

Large emergencies and/or public events are those that PP and potentially DR agencies respond to in a particular area of their jurisdiction; however they are still required to perform their routine operations elsewhere within their jurisdiction. The size and nature of the event may require additional PPDR resources from adjacent jurisdictions, cross-border agencies, or international organizations. In most cases, there are either plans in place or there is some time to plan and coordinate the requirements.

A large fire encompassing 3-4 blocks in a large city (e.g. New York, New Delhi) or a large forest fire are examples of a large emergency under this scenario. Likewise, a large public event (national or international) could include the Commonwealth Heads of Government Meeting (CHOGM), G8 Summit, the Olympics, etc.

Generally, additional radiocommunications equipment for large events is brought to the area as required. This equipment may or may not be linked into the existing PP network infrastructure.

In Tables 2 and 3 of this Annex, large emergencies or public events are referred to as PP (2).

2.3 Disasters

Disasters can be those caused by either natural or human activity. For example, natural disasters include an earthquake, major tropical storm, a major ice storm, floods, etc. Examples of disasters caused by human activity include large-scale criminal incidences or situations of armed conflict. Generally, both the existing PP communications systems and special on-scene communications equipment brought by DR organizations are employed.

Even in areas where suitable terrestrial services exist, MSS systems will play a significant role in disaster situation. The terrestrial services which do exist may have been damaged by the disaster itself, or may be unable to cope with the increased traffic demands resulting from a disaster situation. In these situations, satellite solutions can offer a reliable solution. The frequency bands used by MSS systems are generally harmonised at a global level. However, the cross border circulation of terminals in disaster situations is a critical issue, as recognised in the Tampere Convention. It is imperative that neighbouring countries that may hold MSS terminals as part of their contingency planning are able to offer the initial essential communications required with minimum delay. To this end, advanced bilateral and multilateral agreements are desirable and may be accomplished through, for example the GMPCS-MoU.

Some PPDR agencies/organizations and amateur radio groups use HF narrowband systems including the use of data modes of operation as well as voice. Other technologies such as digital voice, high-speed data and video are in early implementations either using terrestrial or satellite network services.

In Tables 2 and 3 of this Annex, disasters are referred to as DR.

3 Requirements

Tables 2 and 3 of this Annex summarize Sections 3.1 and 3.2, which describe PPDR Application and User Requirements.

When considering these sections, it is important to note that Public Protection organizations currently use various arrangements of mobile systems or a combination thereof, as described below in Table 1.³

TABLE 1
Arrangements of Mobile Systems used by Public Protection

Item	Network Ownership	Operator	User(s)	Spectrum Assignment
a	PP organization	PP organization	PP Exclusive	PP
b	PP organization	Commercial	PP Exclusive	PP
c	Commercial	Commercial	PP Exclusive	PP or Commercial
d	Commercial	Commercial	Shared with PP priority	PP or Commercial
e	Commercial	Commercial	Shared with PP treated as ordinary customer	Commercial

Items b), c), d) and e) of Table 1 in some countries are currently used by PP organizations to supplement their own systems or in some cases to provide all their communications requirements, but not necessarily all the items specified in Tables 2 and 3. It is likely that this trend will continue into the future, particularly with the introduction of advanced wireless solutions, such as IMT-2000.

Some of the applications listed in Section 3.1.3 and Table 2 may depend significantly on commercial systems, while other applications for the same PP organizations may be totally independent of commercial systems.

3.1 Applications

3.1.1 General

- a) Applications associated with the routine day-to-day and emergency operations for public protection applications as outlined in Table 2 could be offered.
- b) Applications associated with disaster relief operations as outlined in Table 2 could be offered.
- c) Regional and/or international harmonization of spectrum for the provision of PPDR applications could be allowed if a requirement is determined for this need.
- d) Applications for PPDR could be developed to support a variety of user terminals including handheld and vehicle-mounted.
- e) The description of environments for PPDR is provided in Section 2 of this Annex.

³ Examples of the types of mobile systems can be found in ITU Recommendations ITU-R M.1073, ITU-R M.1457 and in ITU Report ITU-R M.2014.

3.1.2 Application accessibility requirements

The eventual accessibility of applications for PPDR may depend on various issues. These include the cost, the regulatory and the national legislative climate, the nature of mandates PPDR, and the need of the area to be served. The exact applications and particular features to be provided by the various PPDR organizations are to be decided by such organizations.

3.1.3 Envisioned applications

Table 2 below lists the envisioned applications with particular features and specific PPDR examples. The applications are grouped under the narrowband, wideband or broadband headings to indicate which technologies are most likely to be required to supply the particular application and their features. Furthermore, for each example, the importance (high, medium or low) of that particular application and feature to PPDR is indicated. This importance factor is listed for the three radio operating environments identified in Annex 2, Section 2.1 "Day-to-day operations", Section 2.2 "Large emergency or public events", and Section 2.3 "Disasters", represented by PP (1), PP (2) and DR, respectively.

TABLE 2
PPDR Applications and Examples

Application	Feature	PPDR Example	Importance*		
			PP (1)	PP (2)	DR
1 NARROWBAND					
Voice	Person-to-person	Selective calling and addressing	H	H	H
	One-to-many	Dispatch and group communication	H	H	H
	Talk-around/Direct Mode Operation (DMO)	Groups of portable to portable (mobile-mobile) in close proximity without infrastructure	H	H	H
	Push-to-talk	Push-to-talk	H	H	H
	Instantaneous access to voice path	Push-to-talk and selective priority access	H	H	H
	Security	Voice encryption/scrambling	H	H	M
Facsimile	Person-to-person	Status, short message	L	L	H
	One-to-many (broadcasting)	Initial dispatch alert (e.g. address, incident status)	L	L	H
Messages	Person-to-person	Status, short message, short email	H	H	H
	One-to-many (broadcasting)	Initial dispatch alert (e.g. address, incident status)	H	H	H
Security	Priority/Instantaneous access	Man down alarm button	H	H	H

Telemetry	Location status	GPS latitude and longitude information	H	M	H
	Sensory data	Vehicle telemetry/status	H	H	M
		EKG (electrocardiograph) in field	H	H	M
Database Interaction (minimal record size)	Forms based records query	Accessing vehicle license records	H	H	M
		Accessing criminal records/missing person	H	H	M
	Forms based incident report	Filing field report	H	H	H
2 WIDEBAND					
Messages	E-mail possibly with attachments	Routine e-mail message	M	M	L
Data Talk-around/Direct Mode Operation (DMO)	Direct unit to unit communication without additional infrastructure	Direct handset to handset, on-scene localized communications	H	H	H
Database Interaction (medium record size)	Forms and records query	Accessing medical records	H	H	M
		Lists of identified person/missing person	H	H	H
		GIS (Geographical Information Systems)	H	H	H
Text File Transfer	Data transfer	Filing report from scene of incident	M	M	M
		Records management system information on offenders	H	M	L
		Downloading legislative information	M	M	L
Image Transfer	Download/upload of compressed still images	Biometrics (finger prints)	H	H	M
		ID picture	H	H	M
		Building layout maps	H	H	H
Telemetry	Location status and sensory data	Vehicle status	H	H	H
Security	Priority access	Critical care	H	H	H
Video	Download/upload compressed video	Video clips	M	L	L
		Patient monitoring (may require dedicated link)	M	M	M
		Video feed of in-progress incident	H	H	M
Interactive	Location determination	2-way system	H	H	M
		Interactive location data	H	H	H

3 BROADBAND					
Database Access	Intranet/Internet access	Accessing architectural plans of buildings, location of hazardous materials	H	H	H
	Web browsing	Browsing directory of PPDR organization for phone number	M	M	L
Robotics Control	Remote control of robotic devices	Bomb retrieval robots, imaging/video robots	H	H	M
Video	Video streaming, live video feed	Video communications from wireless clip-on cameras used by in building fire rescue	H	H	H
		Image or video to assist remote medical support	H	H	H
		Surveillance of incident scene by fixed or remote controlled robotic devices	H	H	M
		Assessment of fire/flood scenes from airborne platforms	M	H	M
		Assessment of fire/flood scenes from airborne platforms	M	H	M
Imagery	High resolution imagery	Downloading earth exploration-satellite images	L	L	M
		Real-time Medical imaging	M	M	M
* The importance of that particular application and feature to PPDR is indicated as high (H), medium (M), or low (L). This importance factor is listed for the three radio operating environments: "Day-to-day operations", "Large emergency or public events", and "Disasters", represented by PP (1), PP (2) and DR, respectively.					

3.2 User requirements

This section includes the requirements from the perspective of the PPDR end users. General technology, functional and operational requirements are described. Although some of the requirements do not relate specifically to the radiocommunication network or system used by PPDR, they do affect the design, implementation and use of radiocommunications.

Table 3, at the end of this section, is a general summary of the user requirements. The requirements are grouped under the same headings as Sections 3.2.1 through 3.2.8 and any key attributes related to the requirement are listed in the second column. Furthermore, the importance (high, medium or low) of that particular requirement to PPDR is indicated. This importance factor is listed for the three radio operating environments identified in Section 2.1 "Day to Day Operations", Section 2.2 "Large Emergency or Public Events", and Section 2.3 "Disasters", represented by PP (1), PP (2) and DR, respectively.

The detailed choice of PPDR applications and features to be provided in any given area by PPDR is a national or operator specific matter. However, the capabilities of the service are affected by the following requirements.

3.2.1 System requirements

3.2.1.1 Support of multiple applications

As desired by PPDR organizations, systems serving PPDR should be able to support a broad range of applications, as identified in Section 3.2.

3.2.1.2 Simultaneous use of multiple applications

As desired by the PPDR organization, systems serving PPDR should be able to support the simultaneous use of several different applications with a range of bit rates.

Some PPDR users may require the integration of multiples applications (e.g. voice and low/medium speed data) over the complete network or on a high speed network to service localized areas with intensive on-scene activity.

3.2.1.3 Priority access

As desired by the PPDR organizations, systems serving PPDR should have the ability to manage high priority traffic and possibly manage low priority traffic load shedding during high traffic situations. PPDR may require the exclusive use of frequencies or equivalent high priority access to other systems.

3.2.1.4 Grade of service (GoS) requirements

Suitable grade of service should be provided for PPDR applications.

PPDR users may also require reduced response times for accessing the network and information directly at the scene of incidence, including fast subscriber/network authentication.

3.2.1.5 Coverage

The PPDR system is usually required to provide complete coverage (for "normal" traffic within the relevant jurisdiction and/or operation (national, provincial/state or at the local level). This coverage is required 24 hours/day, 365 days/year.

Usually, systems supporting PPDR organizations are designed for peak loads and wide fluctuations in use. Additional resources, enhancing system capacity may be added during a PP emergency or DR event by techniques such as reconfiguration of networks with intensive use of Direct Mode Operation (DMO) and vehicular repeaters (NB, WB, BB), which may be required for coverage of localized areas.

Systems supporting PPDR are also usually required to provide reliable indoor and outdoor coverage, coverage of remote areas, and coverage of underground or inaccessible areas (e.g. tunnels, building basements). Appropriate redundancy to continue operations when the equipment/infrastructure fails is extremely beneficial.

PPDR systems are not generally installed inside numerous buildings. PPDR entities do not have a continuous revenue stream to support installation and maintenance of an intensive variable density infrastructure. Urban PPDR systems are designed for highly reliable coverage of personal stations outdoors with limited access indoors by direct propagation through the building walls. Sub-systems may be installed in specific building or structures, like tunnels, if penetration through the walls is insufficient. PPDR systems tend to use larger radius cells and higher power mobile and personal stations than commercial service providers.

3.2.1.6 Capabilities

PPDR users require control (full or in part) of their communications, including centralized dispatch (Command and Control Center), access control, dispatch group (talk group) configuration, priority levels, and pre-emption (over ride other users).

Rapid dynamic reconfiguration of the system serving PPDR may be required. This includes robust operation administration and maintenance (OAM) offering status and dynamic reconfiguration. System capability of over-the-air programmability of field units is extremely beneficial.

Robust equipment (e.g. hardware, software, operational and maintenance aspects) are required for systems serving PPDR. Equipment that functions while the user is in motion are also required. Equipment may also require high audio output (high noise environment), unique accessories, such as special microphones, operation while wearing gloves, operation in hostile environments (heat, cold, dust, rain, water, shock, vibration, explosive environments, etc.) and long battery life.

PPDR users may require the system to have capability for fast call set-up, instant push-to-talk operations or one touch broadcasting/group call. Talk-around (direct mode, simplex), communications to aircraft and marine equipment, control of robotic devices, vehicular repeater (on-scene repeater, extend network to remote locations) may also be required.

As the trend continues to move towards IP based solutions, PPDR systems may be required to be IP compatible or be able to interface with IP based solutions.

Appropriate levels of interconnection to the public telecommunications network may also be required⁴. The decision regarding the level of interconnection (i.e. all mobile terminals vs. a percentage of terminals) may be based on the particular PPDR operational requirements. Furthermore, the specific access to the public telecommunications network (i.e. directly from mobile or through the PPDR dispatch) may also be based on the particular PPDR operational requirements.

There may be additional requirements for simulcast (quasi-synchronous broadcast), receiver rating (in-bound path diversity) that have not been covered in Table 3.

3.2.2 Security related requirements

Efficient and reliable PPDR communications within a PPDR organization and between various PPDR organizations, which are capable of secure operation, may be required.

Notwithstanding, there may be occasions where administrations or organisations, which need secure communications, bring equipment to meet their own security requirements.

Furthermore, it should be noted that many administrations have regulations limiting the use of secure communications for visiting PPDR users.

3.2.3 Cost related requirements

Cost effective solutions and applications are extremely important to PPDR users. These can be facilitated by open standards, a competitive marketplace, and economies of scale. Furthermore, cost effective solutions that are widely used can reduce the deployment costs of permanent network infrastructure.

⁴ A description of an international emergency preference scheme (IEPS) is described in ITU-T Recommendation E.106.

3.2.4 Electromagnetic compatibility (EMC) requirements

Systems supporting PPDR should be in accordance with appropriate EMC regulations. Adherence to national EMC regulations may be required between networks, radiocommunications standards and co-located radio equipment.

3.2.5 Operational requirements

This section defines the operational and functional requirements for PPDR users and lists key attributes in Table 3.

3.2.5.1 Scenario

Greater safety of personnel can be accomplished through improved communications. Systems supporting PPDR should be able to operate in the various scenarios, as described in Section 2. PPDR radiocommunication equipment should be able to support at least one of these operating environments, however, it is preferable that PPDR radiocommunication equipment support all of these radio operating environments. For any of these environments, information may be required to flow to and from units in the field to the operational control centre and specialist knowledge centres.

Although the type of operator for systems supporting PPDR is usually a regulatory and national matter, systems supporting PPDR may be satisfied by public or private operators.

PPDR systems and equipment capable of being deployed and set-up rapidly for large emergencies, public events and disasters (e.g. severe floods, large fires, the Olympics, peacekeeping) is extremely beneficial.

3.2.5.2 Interoperability

Interoperability is the seamless, coordinated, and integrated PPDR communications for the safe, effective, and efficient protection of life and property. Communications interoperability can be achieved at many levels of a PPDR operation. From the most basic level, i.e., a fire fighter of one organization communicating with a fire fighter of another, up to the highest levels of command and control.

Various options are available to facilitate communications interoperability between multiple agencies. These include, but are not limited to: a) the use of common frequencies and equipment, b) utilizing local, on-scene command vehicles/equipment/procedures, c) via dispatch centres/patches, or d) utilizing technologies such as audio switches or software defined radios. Typically multiple agencies use a combination of options. Annex 5 provides a more detailed explanation of interoperability and possible solutions.

How these options are used to obtain interoperability depends how the PPDR organizations want to talk to each other and at what level in the organization. Usually, coordination of tactical communications between the on-scene or incident commanders of multiple public protection and disaster relief agencies is required.

Notwithstanding, while the importance of interoperability is recognised, PPDR equipment should be manufactured at a reasonable cost, while incorporating various aspects specific to each country/organization. Administrations should consider the cost implications of interoperable equipment since this requirement should not be so expensive as to preclude implementation within an operational context.

3.2.6 Spectrum usage and management

Depending on national frequency allocations, PPDR users must share with other terrestrial mobile users. The detail arrangements regarding sharing of the spectrum varies from country to country. Furthermore, there may be several different types of systems supporting PPDR operating in the same geographical area. Therefore, interference to systems supporting PPDR from non-PPDR users should be minimized as much as possible.

Depending on the national regulations, systems supporting PPDR may be required to use specific channel spacing between mobile and base station transmit frequencies.

Each administration has the discretion to determine suitable spectrum for PPDR. Annexes 3 and 4 provide additional information on spectrum usage and requirements.

3.2.7 Regulatory compliance

Systems supporting PPDR should comply with the relevant national regulations. In border areas (boundary between countries), suitable coordination of frequencies should be arranged, as appropriate.

Capability of systems supporting PPDR to support extended coverage into the neighbouring country(ies) should also comply with regulatory agreements between the neighbours.

For disaster relief communications, administrations are encouraged to adhere to the principles of the Tampere Convention.

Flexibility should be afforded to PPDR users to employ various types of systems (e.g. HF, satellite, terrestrial, amateur, GMDSS) at the scene of the incident in times of large emergencies and disasters.

3.2.8 Planning

Planning and pre-coordination activities can greatly support PPDR communications. Planning should take into account readily available equipment that could be provided for unpredictable events and disasters through existing inventory thereby reducing the reliance on supplies.

It would be beneficial to maintain accurate and detailed information so that PPDR users can access this information at the scene.

Administrations have, or may also find it beneficial to have, provisions supporting national, state/provincial and local (e.g. municipal) systems.

TABLE 3
User requirements

Requirement	Specifics	Importance*		
		PP (1)	PP (2)	DR
1 System				
Support of multiple applications		H	H	M
Simultaneous use of multiple Applications	Integration of multiple applications (e.g. voice and low/medium speed data)	H	H	M
	Integration of local voice, high speed data and video on high speed network to service localized areas with intensive on-scene activity	H	H	M
Priority access	Manage high priority and low priority traffic load shedding during high traffic	H	H	H
	Accommodate increased traffic loading during major operations and emergencies	H	H	H
	Exclusive use of frequencies or equivalent high priority access to other systems	H	H	H
Grade of service	Suitable grade of service	H	H	H
	Quality of service	H	H	H
	Reduced response times of accessing network and information directly at the scene of incidence, including fast subscriber/network authentication	H	H	H
Coverage	PPDR system should provide complete coverage within relevant jurisdiction and/or operation	H	H	M
	Coverage of relevant jurisdiction and/or operation of PPDR organization whether at national, provincial/state or at local level	H	H	M
	Systems designed for peak loads and wide fluctuations in use	H	H	M
	Enhancing system capacity during PP emergency or DR by techniques such as reconfiguration of networks with intensive use of Direct Mode Operation (DMO)	H	H	H
	Vehicular repeaters (NB, WB, BB) for coverage of localized areas	H	H	H
	Reliable indoor/outdoor coverage	H	H	H
	Coverage of remote areas, underground and inaccessible areas	H	H	H
	Appropriate redundancy to continue operations, when equipment/infrastructure fails	H	H	H

Capabilities	Rapid dynamic reconfiguration of system	H	H	H
	Control of communications including centralized dispatch, access control, dispatch (talk) group configuration, priority levels and pre-emption.	H	H	H
	Robust OAM offering status and dynamic reconfiguration	H	H	H
	Internet Protocol compatibility (complete system or interface with)	M	M	M
	Robust equipment (hardware, software, operational and maintenance aspects)	H	H	H
	Portable equipment (Equipment that can be transmitted while in motion)	H	H	H
	Equipment requiring special features such as high audio output, unique accessories (e.g. special microphones, operation while wearing gloves, operation in hostile environments and long battery life)	H	H	H
	Fast call set-up and instant push-to-talk operation	H	H	H
	Communications to aircraft and marine equipment, control of robotic devices	M	H	L
	One touch broadcasting/group call	H	H	H
	Terminal-to-terminal communications without infrastructure (e.g. Direct Mode Operations (DMO)/talk-around), vehicular repeaters	H	H	H
	Appropriate levels of interconnection to public telecommunication network(s)	M	M	M
	2 Security	End-to-end encrypted communications for mobile-mobile, dispatch and/or group calls communications	H	H
3 Cost Related	Open standards	H	H	H
	Cost effective solution and applications	H	H	H
	Competitive marketplace	H	H	H
	Reduction in deployment of permanent network infrastructure due to availability and commonality of equipment	H	H	L
4 EMC	PPDR systems operation in accordance with national EMC regulations	H	H	H
5 Operational				
Scenario	Support operation of PPDR communications in any environment	H	H	H
	Implementable by public and/or private operator for PPDR applications	H	H	M
	Robust OAM offering status and dynamic reconfiguration	H	H	H
	Rapid deployment of systems and equipment for large emergencies, public events and disasters (e.g. large fires, Olympics, peacekeeping)	H	H	H
	Information to flow to/from units in the field to the operational control center and specialist knowledge centers	H	H	H
	Greater safety of personnel through improved communications	H	H	H

Interoperability	Intra-System: Facilitate the use of common network channels and/or talkgroups	H	H	H
	Inter-Systems: Promote and facilitate the options common between systems	H	H	H
	Coordinate tactical communications between on-scene or incident commanders of the multiple PPDR agencies	H	H	H
6 Spectrum usage and management	Share with other terrestrial mobile users	L	L	M
	Suitable spectrum availability (NB, WB, BB channels)	H	H	H
	Minimize interference to PPDR systems	H	H	H
	Efficient use of spectrum	M	M	M
	Appropriate channel spacing btw mobile and base station frequencies	M	M	M
7 Regulatory Compliance	Comply with relevant national regulations	H	H	H
	Coordination of frequencies in border areas	H	H	M
	Provide capability of PPDR system to support extended coverage into neighbouring country (subject to agreements)	M	M	M
	Ensure flexibility to use various types of systems in other Services (e.g. HF, satellites, amateur) at the scene of large emergency	M	H	H
	Adherence to principles of the Tampere Convention	L	L	H
8 Planning	Reduce reliance on dependencies (e.g. power supply, batteries, fuel, antennas, etc.)	H	H	H
	As required, have readily available equipment (inventoried or through facilitation of greater quantities of equipment)	H	H	H
	Provision to have national, state/provincial and local (e.g. municipal) systems	H	H	M
	Pre-coordination and pre-planning activities (e.g. specific channels identified for use during disaster relief operation, not on a permanent, exclusive basis, but on a priority basis during periods of need)	H	H	H
	Maintain accurate and detailed information so that PPDR users can access this information at the scene	M	M	M

* The importance of that particular requirement to PPDR is indicated as high (H), medium (M), or low (L). This importance factor is listed for the three radio operating environments: "Day-to-day operations", "Large emergency or public events", and "Disasters", represented by PP (1), PP (2) and DR, respectively.

Annex 3

Narrowband frequencies for inter-agency coordination and safety and security communications in international humanitarian assistance presently in use

The Working Group on Emergency Telecommunications (WGET), which is also the Reference Group on Telecommunications (RGT) of the Inter-Agency Standing Committee (IASC) on humanitarian affairs for the United Nations, has adopted and uses the following frequencies whenever the situation permits.

Within the spectrum allocated to land-mobile service in the VHF range:

Primary Channel (A):

Simplex: 163.100 MHz
Duplex: Repeater transmits on 163.100 MHz
Repeater receives on 158.100 MHz

Alternative Channel (B):

Simplex: 163.025 MHz
Duplex: Repeater transmits on 163.025 MHz
Repeater receives on 158.025 MHz

Alternative Channel (C):

Simplex: 163.175 MHz
Duplex: Repeater transmits on 163.175 MHz
Repeater receives on 158.175 MHz

Within the spectrum allocated to land-mobile service in the UHF range:

Primary Channel (UA):

Simplex: 463.100 MHz
Duplex: Repeater transmits on 463.100 MHz
Repeater receives on 458.100 MHz

Alternative Channel (UB):

Simplex: 463.025 MHz
Duplex: Repeater transmits on 463.025 MHz
Repeater receives on 458.025 MHz

Alternative Channel (UC):

Simplex: 463.175 MHz
Duplex: Repeater transmits on 463.175 MHz
Repeater receives on 458.175 MHz

Annex 4

Spectrum requirements for Public Protection And Disaster Relief

1 Introduction

This Annex addresses the estimation of the spectrum requirements for Public Protection and Disaster Relief (PPDR), particularly within the context of WRC-03 agenda Item 1.3. The Annex provides:

- a method of calculating amounts of spectrum;
- system scenarios and assumptions;
- validation of the method with respect to existing applications;
- examples of several administrations projections of their requirements by 2010;
- determining the amount of spectrum which should be harmonized in the context of future applications; and,
- conclusions.

The calculation method given in this Annex is provided for assisting in consolidating spectrum requirements.

A number of administrations have used the modified methodology in Attachment 1 to estimate their national spectrum requirements for PPDR. That methodology, however, is not the only means by which administrations may calculate their national PPDR spectrum needs. Administrations have the discretion to use whatever method, including the modified methodology; they choose to determine their own spectrum requirements for PPDR.

Many PPDR entities around the world are currently evaluating the migration from analog wireless systems to digital for current telecommunication services. The migration to digital will also allow these entities to add some advanced services to these first generation PPDR digital systems. However, there are many more advanced services that PPDR users are likely to demand as they become available to commercial users. While spectrum demand has been estimated and allotted for 2nd and 3rd generation commercial wireless services, similar analysis has not been done for PPDR users.

The greatest demand for public protection and disaster relief telecommunication services is in large cities where different categories of traffic can be found, i.e. that generated by mobile stations (MS), vehicle mounted or portable stations, and personal stations (PS) (hand-held portable radios). The trend is toward designing the PPDR telecommunication network to provide services to personal stations both outdoor and indoor (building penetration).

Maximum demand will be created after a disaster, when many PPDR users converge on the emergency scene utilizing existing telecommunication networks, installing temporary networks, or utilizing vehicle mounted or portable stations. Additional spectrum may be required for interoperability between various PPDR users and/or additional spectrum may be required for installation of temporary disaster relief systems.

Considerations on spectrum demand should take into account the estimated traffic, the available and foreseeable techniques, the propagation characteristics and the time-scale to meet the users' needs to the greatest possible extent. Consideration on frequency matters should take into account that the

traffic generated by mobile systems, as well as the number and diversity of services, will continue to grow. Any estimation of the traffic should take into consideration that in the future, non-voice traffic will constitute an increasing portion of the total traffic and that traffic will be generated indoors as well as outdoors by personal and mobile stations.

2 Methods of projecting spectrum requirements

2.1 Description of the methodology

This Public Protection and Disaster Relief (PPDR) spectrum calculations methodology (Attachment 1 to this Annex) follows the format of the generic methodology that was used for the calculation of IMT-2000 Terrestrial Spectrum Requirements (Recommendation ITU-R M.1390). The use of the methodology can be customized to specific applications by selecting values appropriate to the particular terrestrial mobile application. Another model based on a generic city approach was also used (Attachment 2 to this Annex)

The values selected for the PPDR applications must take into account the fact that PPDR utilizes different technologies and applications (including dispatch and direct mode).

2.2 Required input data

The ITU M.1390 based model and the generic city model require a number of input values which can be categorized as Environment, Traffic or Network Systems. In applying the model to PPDR the main data elements required are:

- the identification of PPDR user categories, e.g. police, fire, ambulance;
- the number of users in each category;
- the estimated number of each user category in use in the busy hour;
- the type of information transmitted, e.g. voice, status message and telemetry;
- the typical area to be covered by the system under study;
- the average cell size of base stations in the area;
- the frequency reuse pattern;
- the grade of service;
- the technology used including RF channel bandwidth.
- the demographic population of the city

2.3 Validity of the methodology

2.3.1 Discussion

Several aspects of the methodology, the assumptions inherent in the model as presented, timing, method of calculation, frequency reuse, possibility of separating the calculations for Public Protection from Disaster Relief, urban as opposed to rural situations, and the nature of the operating environments were clarified in the ITU-R study period 2000-2003.

Specifically, the following issues were raised in connection with the methodology:

- a) Applicability of IMT-2000 methodology to PPDR?
- b) Substituting the geographic areas (e.g. urban, in-building, etc.) in the IMT-2000 methodology by service categories (narrowband, wideband, broadband)?

- c) Use of assumptions of PSWAC Report¹ with regard to assessment of traffic for PPDR?
- d) Treatment of traffic for PP and DR together?
- e) Use of cellular configurations/hotspots in estimating spectrum requirements for PPDR?
- f) Applicability of the methodologies for the simplex/Direct mode operations?

In response, the following points should be noted:

- 1) While the document is based on the methodology used for IMT-2000, the method is capable of including all technologies from simplex to cellular and beyond. Further work will be required to establish appropriate classifications of service environment categories (e.g. for fire, police, emergency medical services) and model systems for those environments, in order to make the calculations needed for each type of use and technology.
- 2) Terms of the calculation of spectrum requirements Public Protection activities could be separated from Disaster Relief activities, with separate and appropriate parameter values and assumptions being applied for each case. However, it was noted that there are instances where Public Protection equipment, which is used for routine operations on a day-by-day basis, may also be employed in times of disaster. In these cases, there would need to be some means established to avoid double counting when undertaking calculations of spectrum requirements.
- 3) In considering the service environments (i.e. narrowband, wideband and broadband), it was noted that those used for IMT-2000 may also have some applicability to public protection and disaster relief communications.

2.3.2 Validity study

One administration undertook the performance of a study of the validity of the results predicted by this methodology. This was done by inputting the parameters of a working narrowband PPDR system into a calculator spreadsheet and checking that the amount of spectrum it predicted was the same as that actually used by the system. It was concluded that this methodology is valid, provided it is used carefully and correctly. It was also concluded that although not validated by actual measurement, one might extrapolate that model works as well for wideband and broadband as long as the input parameters are carefully considered and applied. Another administration reported on a similar study undertaken in which examples were developed for typical cities, obtaining spectrum estimates that are consistent with other examples previously reported. Using two examples of the application of the methodology - one referred to a middle-sized city and the other to an industrial district -- it was concluded that the methodology is appropriate for the evaluation of spectrum needed for PPDR radiocommunication.

2.4 Critical parameters

In assessing the validity of the methodology several critical parameters were identified which must be selected with care. Studies in estimating spectrum requirements for terrestrial land mobile systems were conducted by some administrations showed that the most influential input parameters are:

- cell radius/frequency reuse;
- number of users.

¹ United States Public Safety Wireless Advisory Committee Appendix D, Spectrum Requirements Subcommittee Report September 1996.

The results of the studies were shown to be heavily dependent upon cellular architecture parameters. The studies show that changes in cell radius will change the spectrum estimate significantly. While it is true that reducing the size of the cell radius will increase the reuse of the spectrum and thereby reduce the spectrum requirement, the cost of the infrastructure will also significantly increase. Similar considerations apply to other parameters, e.g. using sectorized cells decreases the necessary spectrum by a factor of three. For these reasons it is advisable that careful studies of cellular structures are undertaken prior to the final specification of the spectrum to be reserved to PPDR.

In preparing the estimate of spectrum amounts, it will be necessary to get consensus on the input data to put into the generic methodology. Noting the sensitivity of the results to such critical parameters, the input data will need to be selected carefully and will need to reflect a balance between the amount of spectrum sought and the infrastructure cost. Countries that need less spectrum than the full amount identified will have greater freedom in network design, the degree of frequency reuse and infrastructure cost.

2.5 Extrapolated upper limit

Korea undertook a parametric analysis of the result of spectrum calculations made for Bhopal, Mexico City, and Seoul. The analysis also used data for other cities taken from other contributions to the work of the ITU-R. The parametric analysis provided insight into PPDR spectrum requirements and it showed that considering the worst case/dense user situation a maximum of 200 MHz (Narrowband: 40 MHz, Wideband: 90 MHz, Broadband: 70 MHz) is needed for the PPDR spectrum requirement for WRC-03 Agenda item 1.3.

3 Results

3.1 Results of estimates of amount of spectrum required by the year 2010 for PPDR

A summary of results of spectrum estimates for PPDR scenarios presented by some administrations using the proposed spectrum calculator methodology is given below. However the data in the last row was made using various other methods.

Location	Narrowband MHz	Wideband MHz	Broadband MHz	Total MHz
Delhi	51.8	3.4	47.6	102.8
Bhopal	24	5.2	32.2	61.4
Seoul	15.1	90.5	69.2	174.8
Mexico City	46.2	39.2	50.2	135.6
Paris	16.6	32.6	-	-
Medium City (Italy high penetration)	21.1	21.6	39.2	81.9
Medium City (Italy medium penetration)	11.6	11.4	39.2	62.2
Industrial District (Italy)	3.0	3.0	39.2	45.2
USA	35.2	12	50.0	97.2

The United States provided its current spectrum designations for PPDR and did not use the proposed methodology. The United States reported that it has designated a total of 35.2 MHz of spectrum for local and state PPDR agencies to use for narrowband applications. In addition, 12 MHz of spectrum has been designated in the United States for wideband PPDR applications. The United States has designated 50 MHz spectrum for broadband PPDR applications. The United States is continually reviewing its spectrum decisions to determine if spectrum has been designated appropriately for state and local PPDR applications.

3.2 Discussion of results

The totals listed in the above chart cover all the PPDR applications and both uplink and downlink requirements. The results range between 45 MHz and 175 MHz. Such results have to be compared with the national current and forecasted situations taking into account the whole spectrum needed by PPDR users.

There are several reasons for the wide range of spectrum estimates. First, the studies done in obtaining these results showed that the spectrum estimates are very dependent on density and the penetration rate. Second, administrations based their spectrum calculations on whatever scenarios they deemed most appropriate. For example, Korea based its spectrum calculations on the worst case/most dense user requirement. Italy chose to examine the PPDR spectrum needs of a typical medium-size city in Italy. Other administrations used other scenarios.

Many countries do not envisage having physically separate PP and DR networks in their countries and therefore see global/regional harmonization as applying to both PP and DR requirements. Other countries may decide to calculate separate PP and DR spectrum requirements.

Attachment 1

(to Annex 4)

Methodology for the calculation of public protection and disaster relief terrestrial spectrum requirements

Introduction

The function of this attachment is to present an initial forecast for spectrum needed by Public Protection and Disaster Relief by the year 2010. A spectrum calculator methodology, following the format of ITU methodology for the calculation of IMT-2000 spectrum requirements, is developed. Because of the differences between commercial wireless users and PPDR wireless users, alternate methodologies are proposed to calculate PPDR user penetration rates and define the PPDR operational environments. Methodologies are also proposed to define PPDR Net System Capacity and PPDR Quality of Service.

The analysis is based upon current PPDR wireless technologies and expected trends in demand for advanced applications. From that, an initial forecast can be made for the amount of spectrum needed for specific advanced telecommunication services through the year 2010.

Advanced services

The advanced services likely to be available to PPDR community by year 2010 are:

- voice dispatch;
- telephone interconnect;
- simple messages;
- transaction processing;
- simple images (facsimile, snapshot);
- remote file access for decision processing;
- Internet/intranet access;
- slow video;
- full motion video;
- multimedia services, like videoconference.

A Spectrum prediction model

This spectrum prediction model follows the methodology for the prediction of IMT-2000 Spectrum Requirements (Recommendation ITU-R M.1390).

The steps to be used are:

- 1) identify the geographical area over which the model will be applied;
- 2) identify the population of public protection and disaster relief personnel;
- 3) identify the advanced services used by the PPDR community through year 2010;

- 4) quantify technical parameters that apply to each of the advanced services;
- 5) forecast the spectral need for each advanced service;
- 6) forecast total spectral need for PPDR through year 2010.

See Appendix A for comparison of proposed PPDR methodology versus Recommendation ITU-R M.1390 methodology. See Appendix B for flowchart of proposed PPDR methodology.

B Geographical area

Determine the PPDR user populations within the area of the study.

For this model, we do not need to investigate spectrum demand over an entire country. The area(s) of interest will be one or more of the major metropolitan regions within each country. The population density is highest in these areas. The proportion of PPDR personnel relative to the general population is expected to be highest here, also. Therefore, the demand for spectrum resources should also be highest in the major metropolitan area(s). This is similar to the ITU-2000 methodology where the geography and environments of only the most significant contributors to spectrum requirements are considered.

We need to clearly define the geographic and/or political boundaries of the metropolitan area of study. This may be the political boundary of the city or of the city and surrounding suburban cities and/or counties in the metropolitan area. We need general population data for the metropolitan area. This should be readily available from census data.

Instead of using general population density (population/km²), the PPDR population and penetration rates must be determined. Within the geo/political boundaries of the study area, PPDR population must be defined and divided by the area to determine the PPDR user density (PPDR/km²).

Representative cell area (radius, geometry) needs to be determined for each operational environment within the geographic study area. This is dependent upon the population density, network design, and network technology. PPDR networks tend to utilize higher power devices and larger radius cells than commercial systems.

Follow IMT-2000 Methodology A:

Define geographic boundaries and area (km²) of each environment

C Operational environments versus service environments

In the methodology for the calculation of IMT-2000 spectrum requirements, the analysis is conducted on physical operational environments. These environments vary significantly in cell geometry and/or population density. PPDR population density is much lower than the general population density. PPDR networks generally provide wireless services into all physical environments from one, or more, wide-area network(s). This model defines "service environments" which group services by the type of PPDR wireless telecommunication network: narrowband, wideband, broadband. Many of services are currently and will continue to be delivered by networks using narrowband channels (25 kHz bandwidth or less). These include dispatch voice, transaction processing, and simple images. More advanced services like internet/intranet access and slow video will require a wideband channel (50 to 250 kHz) to deliver these higher content services. Full motion video and multi-media services will require very wide channels (1 to 10 MHz) to deliver real-time images. These three "service environments" will likely be deployed as separate overlapping networks utilizing different cell geometries and different network and subscriber technologies.

Also, the services offered within each "service environment" will need to be defined.

Modified version of IMT-2000 Methodology A1, A2, A3, A4, B1:

Define "service environment" = narrowband, wideband, broadband.

Determine direction of calculations for each environment; uplink, downlink, combined.

Determine average/typical cell geometry within each "service" environment.

Calculate representative cell area within each "service" environment.

Define Services Offered in each "service environment" and Net User Bit Rate for each.

D PPDR population

Who are PPDR users? These are personnel who would respond to day-to-day emergencies and to disasters. They would typically be public protection personnel grouped into mission oriented categories, like police, fire brigades, emergency medical response. For disasters the scope of responders may increase to include other government personnel or civilians. All these PPDR personnel would be using PPDR telecommunication services during an emergency or disaster. PPDR users may be combined together into categories that have similar wireless communication usage patterns, i.e. the assumption is that all users grouped into "police" category personnel would have similar demands for telecommunication services.

For this model, the categories will only be used to group PPDR users with similar wireless service usage rates. That is, for police, each officer may have a radio, so the wireless penetration rate is 100% for police. For ambulance crews, there may be two people assigned to an ambulance, but only one radio, so the penetration rate is only 50% for ambulance crews. The current penetration rate can easily be determined if the number of mobile and portable stations deployed is known. It is simply the ratio of the number of radios deployed to the number of PPDR users in that category.

We need to determine the PPDR user populations. This can be collected for each PPDR user category; police, law enforcement, fire brigade, emergency medical response, etc. This data may be collected from the specific metropolitan governments or PPDR agencies. This data may be available from several public sources, including annual budgets, census data, and reports published by national or local law enforcements agencies.

The data may be presented in several formats, which must be converted into the total counts from each source for each PPDR category within the area of study.

- Some data may be presented as specific PPDR user counts within a political sub-division; e.g. city A with a population of nnnnn has AA police officers, BB fire fighters, CC ambulance drivers, DD transit police, EE traffic wardens, and FF civilian support personnel.
- Some data may be presented as a percentage relative to the total population; e.g. there are XXX police officers per 100 000 population. This needs to be multiplied by the population within the area of study to calculate the total count for each PPDR category.
- There may be multiple levels of government within the area of study. The PPDR totals for each category need to be combined. Local police, county police, state police, and federal police would be combined into a single "police" category. The assumption is that all these "police" category personnel would have similar demands for telecommunication services.

Example of PPDR Categories:

Regular Police	Fire Brigades	Emergency Medical Services
Special Police Functions	Part-time Fire	EMS Civilian Support
Police Civilian Support	Fire Civilian Support	
General Government Personnel	Other PPDR Users	

Growth projections for population and planned increases in PPDR personnel may be used to estimate the future number of PPDR personnel within the area of study in 2010. Analysis over the study area may show that some towns/cities within the area of study do not provide advanced PPDR services today, but plan to deliver those services within the next 10 years. Growth projection may simply be the application of the higher PPDR user population density figures from cities/towns using advanced wireless services today within the area of study to all parts of the study area.

Modified version of IMT-2000 Methodology B2:

Determine PPDR population density within study area.

- Calculate for each mission oriented category of PPDR user or for groups of PPDR users with similar service usage patterns.

E Penetration rates

Instead of using penetration rates from commercial wireless market analyses, the PPDR penetration rates for current and future wireless telecommunication services must be determined. It is expected that the ITU-R Working Party 8A survey on public protection and disaster relief (PPDR) communications will supply some of this data. One method would be to determine the penetration rate of each telecommunication service within each of the PPDR categories defined above, then convert this to the composite PPDR penetration rate for each telecommunication service within each environment.

Modified version of IMT-2000 Methodology B3, B4:

Calculate PPDR Population Density.

- Calculate for each category of PPDR user.

Determine Penetration Rate for each Service within each Environment.

Determine Users/Cell for each Service within each Environment.

F Traffic parameters

The proposed model follows the IMT methodology. Traffic parameters used in examples below represent average for all PPDR users. However, these traffic parameters could also be calculated for individual PPDR categories and combined to calculate composite Traffic/User. Much of this data was determined by PSWAC² and that busy hour traffic data will be used in the examples presented below. The "busy hour call attempts" are defined as the ratio between the total number of connected calls/sessions during the busy hour and the total number of PPDR users in the study area during the busy hour. Much of this data was determined by PSWAC and that busy hour traffic data will be used in the examples presented below. The activity factor is assumed to be 1 for all services, including PPDR speech. Current PPDR systems do not use vocoders with discontinuous voice transmission, so PPDR speech continuously occupies the channel and the PPDR speech activity factor is 1.

² United States, Public Safety Wireless Advisory Committee, Appendix D, Spectrum Requirements Sub-Committee Report, September 1996.

Follow IMT-2000 Methodology B5, B6, B7:

Determine Busy Hour Call Attempts per PPDR user for each service in each environment.

Determine Effective Call/Session Duration.

Determine Activity Factor.

Calculate Busy Hour Traffic per PPDR user.

Calculate Offered Traffic/Cell (erlangs) for each service in each environment.

Example Traffic Profiles from PSWAC Report:

PSWAC Traffic Profile Summary		Erlangs Inbound	Erlangs Outbound	Erlangs Total	Seconds	Ratio of Busy Hour to Avg hour	Continuous bps @ 4800 bps
Voice	Current Busy Hour	0.0073484	0.0462886	0.0536370	193.1	4.00	85.8
	Current Avg Hour	0.0018371	0.0115722	0.0134093	48.3		21.5
	Future Busy Hour	0.0077384	0.0463105	0.0540489	194.6	4.03	86.5
	Future Avg hour	0.0018321	0.0115776	0.0134097	48.3		21.5
Data	Current Busy Hour	0.0004856	0.0013018	0.0017874	6.4	4.00	2.9
	Current Avg Hour	0.0001214	0.0003254	0.0004468	1.6		0.7
	Future Busy Hour	0.0030201	0.0057000	0.0087201	31.4	4.00	14.0
	Future Avg hour	0.0007550	0.0014250	0.0021800	7.8		3.5
Status	Current Busy Hour	0.0000357	0.0000232	0.0000589	0.2	4.01	0.1
	Current Avg Hour	0.0000089	0.0000058	0.0000147	0.1		0.0
	Future Busy Hour	0.0001540	0.0002223	0.0003763	1.4	3.96	0.6
	Future Avg hour	0.00	0.00	0.00	0.34		0.15
Image	Future Busy Hour	0.0268314	0.0266667	0.0534981	192.6	4.00	85.6
	Future Avg hour	0.0067078	0.0066670	0.0133748	48.1		21.4

G PPDR quality of service functions

The ITU-2000 methodology takes the Offered Traffic/Cell, converts to the number of traffic channels required to carry that load in a typical cell reuse grouping, and then applies grade of service formulas to determine the number of service channels needed in a typical cell. The same methodology is proposed here, but the factors used for PPDR networks are significantly different.

For PPDR systems the reuse pattern is typically much higher than commercial wireless services. Commercial wireless services are normally designed to use low power devices with power control in an interference limited environment. PPDR systems are typically designed to be "coverage" or "noise" limited. Many PPDR systems use a mixture of high power vehicular devices and low power handheld devices, without power control. Therefore, the separation or reuse distance is much greater for PPDR systems, in the range of 12 to 21.

The technology modularity of PPDR systems is often different than commercial systems. There may be 2 or more networks covering the same geographic area, in different frequency bands, supporting the PPDR personnel from different levels of government or in different PPDR categories (federal network may be independent of local network; police network may be independent of fire network). The result is networks with fewer channels resources per cell.

PPDR networks are normally designed for higher coverage reliabilities, 95 to 97%, because they are trying to cover all operational environments from a fixed network. Commercial networks, with a revenue stream, can continuously adapt their networks to changing user needs. PPDR networks, funded with public monies, normally undergo minimal change in cell locations or service channels per cell over their lifetime of 10-20 years.

For PPDR services, availability of the channel must be very high, even during busy hours, because of the immediate need to transmit critical, sometimes life-saving, information. PPDR networks are designed for lower call blocking levels, <1%, as PPDR personnel need immediate access to the network during emergency situations. While many routine conversations and data transactions can wait several seconds for a response, many PPDR situations are highly tense and require immediate channel availability and response.

Loading varies greatly for different PPDR network topologies and for different PPDR situations. Many police or fire situations may require individual channels to be set aside for on-scene interoperability with very low loading, <10%. Conventional, single channel, mobile relay systems in use today typically operate at 20-25% loading, because unacceptable blockage occurs at higher loading. Large 20 channel trunked systems, which spread the load across all available channels, with a mix of critical and non-critical users, may be able to operate at acceptable levels for critical PPDR operations with busy hour loading of 70-80%.

The net impact causes the Erlang B factor for the average PPDR network to be higher, about 1.5, instead of the 1.1 to 1.2 factors seen with commercial services at 90% coverage and 1% blocking.

Follow IMT Methodology B8:

Unique PPDR requirements:

Blocking = <1%

Modularity = ~ 20 channels per cell per network, results in high erlang B factor of about 1.5.

Frequency reuse cell format;

= 12 for like power mobile or personal stations,

= 21 for mixture of high/low power mobile and personal stations.

Determine number of service channels needed for each service in each "service" environment (NB, WB, BB)

H Calculate total traffic

The proposed model follows the IMT methodology. The PPDR Net User Bit Rate should include the raw data rate, the overhead factor and the coding factor. This is dependent upon the technology chosen for each service.

Information is coded to reduce or compress the content which minimizes the amount of data to be transmitted over an RF channel. Voice, which may be coded at a rate of 64 kbit/s or 32 kbit/s for wireline applications, is coded at rates of less than 4 800 bit/s for PPDR dispatch speech applications. The more the information is compressed, the more important each bit becomes, and the more important the error correction function becomes. Error coding rates from 50% to 100% of information content are typical. Higher transmission rates over the harsh multi-path propagation environment of an RF channel require additional synchronization and equalization functions, which use additional capacity. Also, other network access and control functions need to be carried along with the information payload (unit identity, network access functions, encryption).

PPDR systems in operation today use 50-55% of the transmitted bit rate for error correction and overhead.

For example: one technology for speech on narrowband channels may have a speech vocoder output rate of 4.8 kbit/s with a forward error correction rate of 2.4 kbit/s and the protocol may be provisioned for another 2.4 kbit/s of overhead signalling and information bits, for a Net User Bit Rate of 9.6 kbit/s.

Follow IMT Methodology C1, C2, C3:

Define net user bit rate, overhead factors, coding factors for each service in each "service" environment.

Convert service channels from B8 back to per cell basis.

Calculate Total Traffic (MB/s) for each service in each "service" environment

I Net System Capacity

The Net System Capacity is an important measure of the spectrum efficiency of a wireless telecommunications system. The Net System Capacity calculation produces the maximum system capacity possible within the spectrum band being studied.

The proposed model follows the IMT methodology. However, calculation of PPDR Net System Capacity should be based upon typical PPDR technologies, PPDR frequency bands, and PPDR reuse patterns, rather than the GSM model used in the ITU-2000 methodology.

Appendix C provides analysis for several PPDR technologies currently in use against some existing PPDR spectrum allocations. These examples show maximum possible system capacity for the purpose of estimating future spectrum requirements. There are numerous other user requirements and spectrum allocation factors, not included here, that effect the functional and operational deployment of a network, the choice of technology, and resulting network's spectrum efficiency.

Follow IMT-2000 Methodology C4, C5:

Pick several PPDR network technologies.

Pick several representative frequency bands.

Follow same calculations format as ITU GSM model.

Calculate typical Net System Capacities for PPDR LMR technology.

J Spectrum calculations

The proposed model follows the IMT methodology.

PPDR networks are very likely to have coincident busy hours. Therefore the alpha factor will be 1.0.

The number of PPDR personnel is likely to grow with general population growth. The demand for PPDR services is likely to increase following trends similar to the demand for commercial wireless telecommunication services.

The beta factor can be set to a number greater than 1.0 here, or the growth factor can be included in the Net System Capacity calculations.

Follow IMT-2000 methodology D1, D2, D3, D4, D5, D6:

Define Alpha factor = 1.

Define beta factor = 1 (include growth under Net System capacity, ignore other outside effects for example calculations).

Calculate spectrum need for each service in each "service" environment.

Sum up spectrum needs for each "service" environment (NB, WB, BB).

Sum up total spectrum need.

Examples

See Appendix E for detailed narrowband voice example using London data from Appendix D. Appendix F shows example calculation summaries for narrowband voice, message, and image for London and New York City and for wideband data and slow video for New York City.

Conclusion

It has been demonstrated that the IMT-2000 methodology (Recommendation ITU-R M.1390) may be adapted to calculate the system requirements for Public Protection and Disaster Relief (PPDR) communications (or applications). Methods have been provided to determine the PPDR user population and service penetration rates. "Service" environments have been defined over which PPDR spectrum requirements can be calculated. The factors necessary to adapt the IMT-2000 methodology to a PPDR methodology have been identified, including the development of a methodology to define PPDR Net System Capacity.

Appendix A

(of Attachment 1 to Annex 4)

Comparison of proposed methodology for the calculation of public protection and disaster relief spectrum requirements to IMT-2000 methodology

IMT-2000 Methodology (Rec. ITU-R M.1390)	IMT-2000 Methodology	Proposed PPDR Methodology
A Geography		
A1 Operational Environment Combination of user mobility and user mobility. Usually only analyse most significant contributors.	A1 look at three physical environments with different user densities: urban area and in-building, pedestrian, vehicular users	A1 PPDR user density is much lower and more uniform. PPDR users roam from one environment to another as they respond to emergencies. PPDR systems are usually designed to cover all environments (i.e., wide-area network provides in-building coverage). Instead of analyzing by physical environment, assume that there will likely be multiple overlapping systems each providing different services (narrowband, wideband, and broadband). Each service environment will probably operate in a different frequency band with different network architectures. Analyse three overlapping urban "service environments": narrowband, wideband, broadband.
A2 Direction of calculation	A2 Usually separate calculations for uplink and downlink due to asymmetry in some services	A2 Same
A3 Representative cell area and geometry for each environment type	A3 Average cell radius of radius to vertex for hexagonal cells;	A3 Same
A4 Calculate area of typical cell	A4 Omni cells = $\pi \times R^2$ Hex cells = $2.6 \times R^2$ 3-sector hex = $2.6/3 \times R^2$	A4 Same

IMT-2000 Methodology (Rec. ITU-R M.1390)	IMT-2000 Methodology	Proposed PPDR Methodology																								
B Market & Traffic																										
B1 Services Offered	B1 Net User Bit Rate (kbit/s) For each service: speech, circuit data, simple messages, medium multimedia, high multimedia, highly interactive multimedia.	B1 Net User Bit Rate (kbit/s) for each of the three PPDR service environments: narrowband, wideband, broadband																								
B2 Population Density Persons per unit of area within each environment. Population density varies with mobility.	B2 Potential users per km ² Relative to general population	<p>B2 Total PPDR user population within the total area under consideration. Divide PPDR population by total area to get PPDR population density.</p> <p>PPDR users are usually separated into well-defined categories by mission. Example:</p> <table data-bbox="1283 730 1765 1137"> <tr> <td>CATEGORY</td> <td>POP</td> </tr> <tr> <td>Regular Police,</td> <td>25498</td> </tr> <tr> <td>Special Police functions,</td> <td>6010</td> </tr> <tr> <td>Police Civilian support,</td> <td>13987</td> </tr> <tr> <td>Fire Suppression,</td> <td>7081</td> </tr> <tr> <td>Part-time Fire,</td> <td>2127</td> </tr> <tr> <td>Fire Civilian Support,</td> <td>0</td> </tr> <tr> <td>Emergency Medical Services,</td> <td>0</td> </tr> <tr> <td>EMS Civilian support,</td> <td>0</td> </tr> <tr> <td>General Government Services,</td> <td>0</td> </tr> <tr> <td>Other PPDR users.</td> <td>0</td> </tr> <tr> <td>TOTAL PPDR Population</td> <td>54703</td> </tr> </table> <p>Area under consideration. Area within well-defined geographic or political boundaries.</p> <p>Example: City of London 1 620 km²</p> <p>PPDR Population Density = PPDR population/area</p> <p>Example: London 33.8 PPDR/km²</p>	CATEGORY	POP	Regular Police,	25498	Special Police functions,	6010	Police Civilian support,	13987	Fire Suppression,	7081	Part-time Fire,	2127	Fire Civilian Support,	0	Emergency Medical Services,	0	EMS Civilian support,	0	General Government Services,	0	Other PPDR users.	0	TOTAL PPDR Population	54703
CATEGORY	POP																									
Regular Police,	25498																									
Special Police functions,	6010																									
Police Civilian support,	13987																									
Fire Suppression,	7081																									
Part-time Fire,	2127																									
Fire Civilian Support,	0																									
Emergency Medical Services,	0																									
EMS Civilian support,	0																									
General Government Services,	0																									
Other PPDR users.	0																									
TOTAL PPDR Population	54703																									

IMT-2000 Methodology (Rec. ITU-R M.1390)	IMT-2000 Methodology	Proposed PPDR Methodology																																							
<p>B3 Penetration Rate</p> <p>Percentage of persons subscribing to a service within an environment. Person may subscribe to more than one service.</p>	<p>B3 Usually shown as table,</p> <p>Rows are services defined in B1, such as speech, circuit data, simple messages, medium multi-media, high multimedia, highly interactive multimedia.</p> <p>Columns are environments, such as in-building, pedestrian, vehicular</p>	<p>B3 Similar table.</p> <p>Rows are services, such as voice, data, video</p> <p>Columns are "service environments", such as narrowband, wideband, broadband.</p> <p>May collect penetration rate into each "service environment" separately for each PPDR category and then calculate composite PPDR penetration rate.</p> <p>Example:</p> <table border="0" data-bbox="1283 630 1960 1069"> <thead> <tr> <th>CATEGORY</th> <th>POP (NB Voice)</th> <th>PEN</th> </tr> </thead> <tbody> <tr> <td>Regular Police,</td> <td>25498</td> <td>100%</td> </tr> <tr> <td>Special Police functions,</td> <td>6010</td> <td>10%</td> </tr> <tr> <td>Police Civilian support,</td> <td>13987</td> <td>10%</td> </tr> <tr> <td>Fire Suppression,</td> <td>7081</td> <td>70%</td> </tr> <tr> <td>Part-time Fire,</td> <td>2127</td> <td>10%</td> </tr> <tr> <td>Fire Civilian Support,</td> <td>0</td> <td>0</td> </tr> <tr> <td>Emergency Medical Services,</td> <td>0</td> <td>0</td> </tr> <tr> <td>EMS Civilian support,</td> <td>0</td> <td>0</td> </tr> <tr> <td>General Government Services,</td> <td>0</td> <td>0</td> </tr> <tr> <td>Other PPDR users.</td> <td>0</td> <td>0</td> </tr> <tr> <td>TOTAL PPDR Population</td> <td>54703</td> <td>_____</td> </tr> <tr> <td>Narrowband Voice PPDR Population</td> <td>32667</td> <td></td> </tr> </tbody> </table> <p>PPDR Penetration Rate for narrowband "service environment" and voice "service":</p> <p>= $\text{Sum}(\text{POP} \times \text{PEN}) / \text{sum}(\text{POP}) = 59.7\%$</p>	CATEGORY	POP (NB Voice)	PEN	Regular Police,	25498	100%	Special Police functions,	6010	10%	Police Civilian support,	13987	10%	Fire Suppression,	7081	70%	Part-time Fire,	2127	10%	Fire Civilian Support,	0	0	Emergency Medical Services,	0	0	EMS Civilian support,	0	0	General Government Services,	0	0	Other PPDR users.	0	0	TOTAL PPDR Population	54703	_____	Narrowband Voice PPDR Population	32667	
CATEGORY	POP (NB Voice)	PEN																																							
Regular Police,	25498	100%																																							
Special Police functions,	6010	10%																																							
Police Civilian support,	13987	10%																																							
Fire Suppression,	7081	70%																																							
Part-time Fire,	2127	10%																																							
Fire Civilian Support,	0	0																																							
Emergency Medical Services,	0	0																																							
EMS Civilian support,	0	0																																							
General Government Services,	0	0																																							
Other PPDR users.	0	0																																							
TOTAL PPDR Population	54703	_____																																							
Narrowband Voice PPDR Population	32667																																								
<p>B4 Users/Cell</p> <p>Number of people subscribing to service within cell in environment</p>	<p>B4 Users/Cell</p> <p>= $\text{PopDensity} \times \text{PenRate} \times \text{CellArea}$</p>	<p>B4 Same</p>																																							

IMT-2000 Methodology (Rec. ITU-R M.1390)	IMT-2000 Methodology	Proposed PPDR Methodology
<p>B5 Traffic Parameters</p> <p>Busy Hour Call Attempts Average number of calls/sessions attempted to/from average user during a busy hour</p> <p>Effective Call Duration Average call/session duration during busy hour</p> <p>Activity Factor Percentage of time that resource is actually used during a call/session. Example: bursty packet data may not use channel during entire session. If voice vocoder does not transmit data during voice pauses</p>	<p>B5 Calls/Busy Hour</p> <p>Seconds/Call</p> <p>0-100%</p>	<p>B5 Same</p> <p>Sources- PSWAC Report or data collected from existing PPDR systems</p> <p>Same</p> <p>Same</p> <p>More likely that activity factor is 100% for most PPDR services.</p>
<p>B6 Traffic/User</p> <p>Average traffic generated by each user during busy hour</p>	<p>B6 Call-seconds/User</p> <p>= BusyHourAttempts x CallDuration x ActivityFactor</p>	<p>B6 Same</p>
<p>B7 Offered Traffic/Cell</p> <p>Average Traffic generated by all users within a cell during the busy hour (3 600 seconds)</p>	<p>B7 Erlangs</p> <p>= Traffic/User x User/Cell/3 600</p>	<p>B7 Same</p>

IMT-2000 Methodology (Rec. ITU-R M.1390)	IMT-2000 Methodology	Proposed PPDR Methodology
<p>B8 Quality of Service Function Offered Traffic/Cell is multiplied by typical frequency reuse cell grouping size and Quality of Service factors (blocking function) to estimate Offered Traffic/Cell at a given quality level</p> <p>Group Size</p> <p>Traffic per Group</p> <p>Service Channels per Group</p>	<p>Typical Cellular reuse = 7</p> <p>= Traffic/Cell (erlangs) x GroupSize</p> <p>Apply Grade of Service formulas</p> <p>Circuit = Erlang B with 1 or 2% blocking Packet = Erlang C w/ 1 or 2% delayed and delay/holding time ratio = 0.5</p>	<p>Use 12 for portable only or mobile only systems Use 21 for mixed portable and mobile systems. In mixed systems, assume that system is designed for portable coverage. Higher power mobiles in distant cells are likely to, so group size is increased from 12 to 21 to provide more separation.</p> <p>Same</p> <p>Similar</p> <p>Use 1% blocking. Erlang B factor probably close to 1.5.</p> <p>Need to consider extra reliability for PPDR systems, excess capacity for peak emergencies, and number of channels likely to be deployed at each PPDR antenna site. Technology modularity may affect number of channels that can be deployed at a site.</p>

IMT-2000 Methodology (Rec. ITU-R M.1390)	IMT-2000 Methodology	Proposed PPDR Methodology
C Technical and System Considerations C1 Service Channels per Cell to carry Offered Load	C1 $\text{ServiceChannelsPerCell} = \frac{\text{ServiceChannelsPerGroup}}{\text{GroupSize}}$	C1 Same
C2 Service Channel Bit Rate (kilobits/sec) Equals net user bit rate plus additional increase in loading due to coding and/or overhead signalling, if not already included.	C2 $\text{ServiceChannelBitRate} = \text{NetUserBitRate} \times \text{OverheadFactor} \times \text{Coding Factor}$ If coding and overhead already included in NetUserBitRate, then Coding factor = 1 and Overhead factor = 1	C2 Same Can also sum effects of coding and overhead If vocoder output = 4.8 kb/s, FEC = 2.4 kb/s, and Overhead = 2.4 kb/s, then ChannelBitRate = 9.6 kb/s
C3 Calculate Traffic (Mb/s) Total traffic transmitted within area under study, including all factors	C3 Total Traffic $= \text{ServiceChannelsPerCell} \times \text{ServiceChannelBitRate}$	C3 Same
C4 Net System Capability Measure of system capacity for a specific technology. Related to spectral efficiency.	C4 Calculate for GSM system	C4 Calculate for typical narrowband, wideband, and broadband Land Mobile systems
C5 Calculate for GSM model 200 kHz channel bandwidth, 9 cell reuse, 8 traffic slots per carrier, FDD w/ 2 x 5.8 MHz, 2 guard channels, 13 kb/s in each traffic slot, 1.75 overhead/coding factor	C5 Net System Capacity for GSM model $= 0.1 \text{ MB/s/MHz/cell}$	C5 See Appendix A for several Land Mobile examples

IMT-2000 Methodology (Rec. ITU-R M.1390)	IMT-2000 Methodology	Proposed PPDR Methodology
D Spectrum Results		
D1-D4 Calculate individual components (each cell in service vs environment matrix)	D1-D4 Freq = Traffic/Net SystemCapacity for each service in each environment	D1-D4 Similar, calculate for each cell in service vs "service environment" matrix
D5 Weighting Factor (alpha) for busy hour of each environment relative to busy hour of other environments, may vary from 0 to 1	D5 if all environments have coincident busy hours, then alpha = 1 $Freq_{es} = Freq \times \alpha$ requirements in D1-D4	D5 Same Same
D6 Adjustment Factor (beta) for outside effects – multiple operators/networks, guard bands, band sharing, technology modularity	D6 $Freq(\text{Total}) = \beta \times \sum(\alpha \times Freq_{es})$	D6 Same

Appendix B

(to Attachment 1 to Annex 4)

Public Protection and Disaster Relief Spectrum Requirements Flowchart

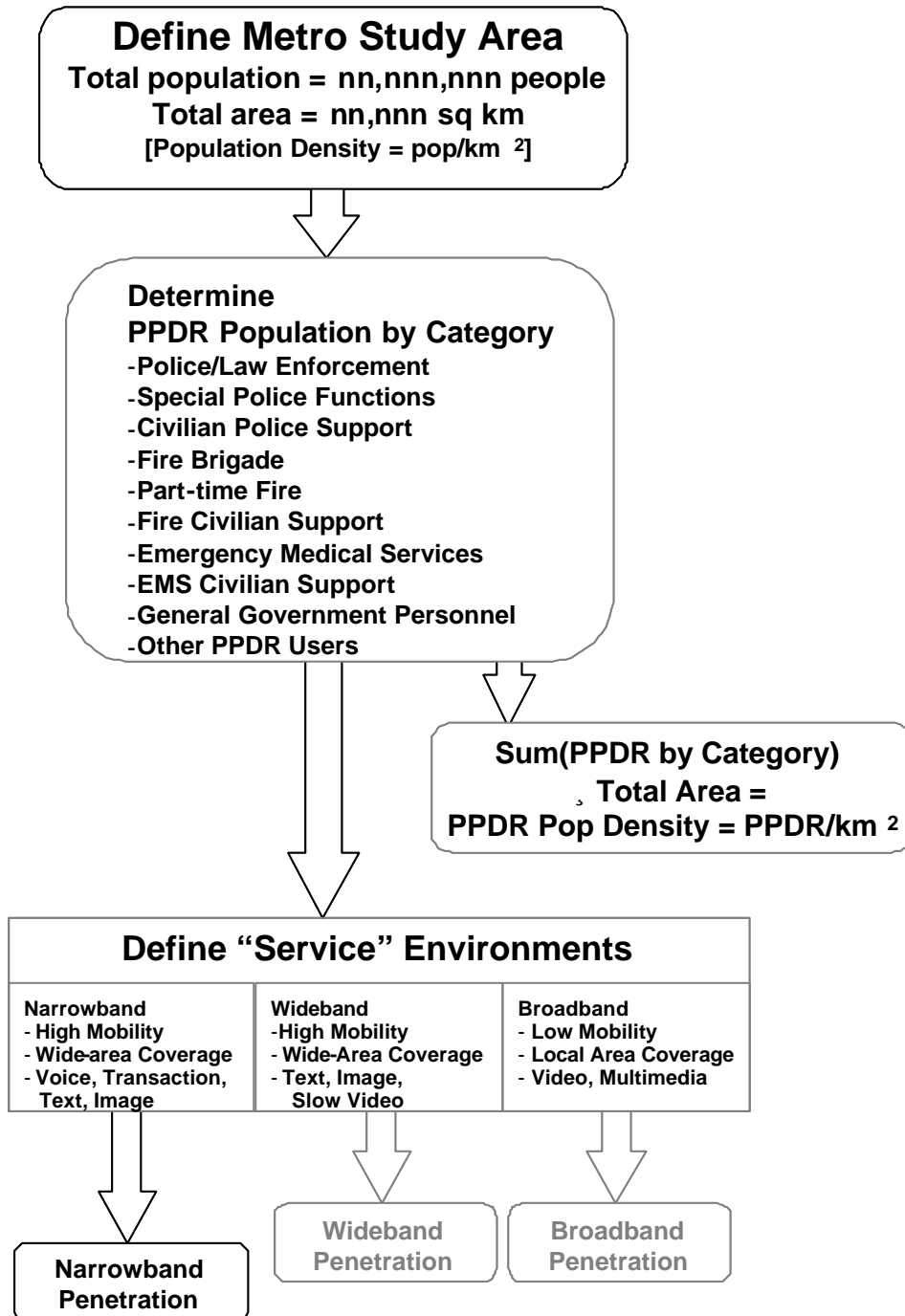

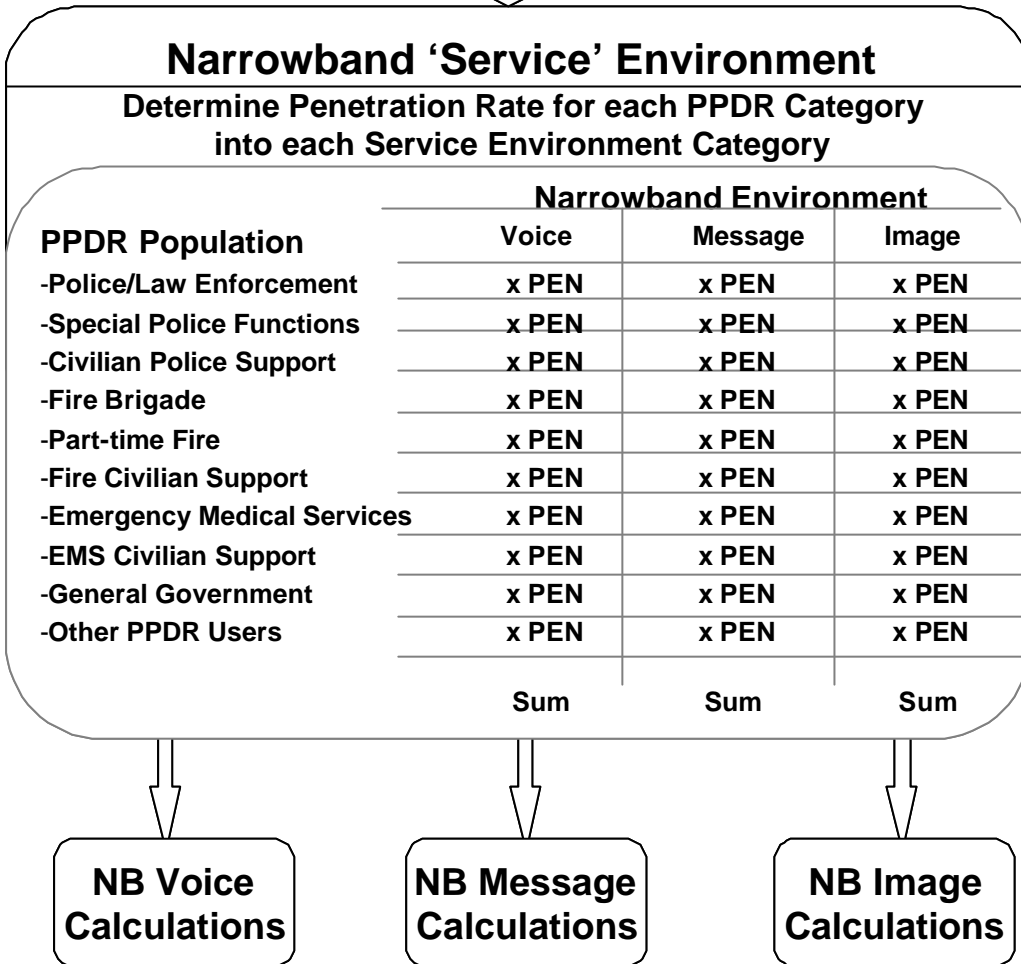
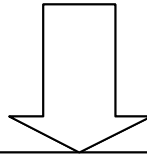

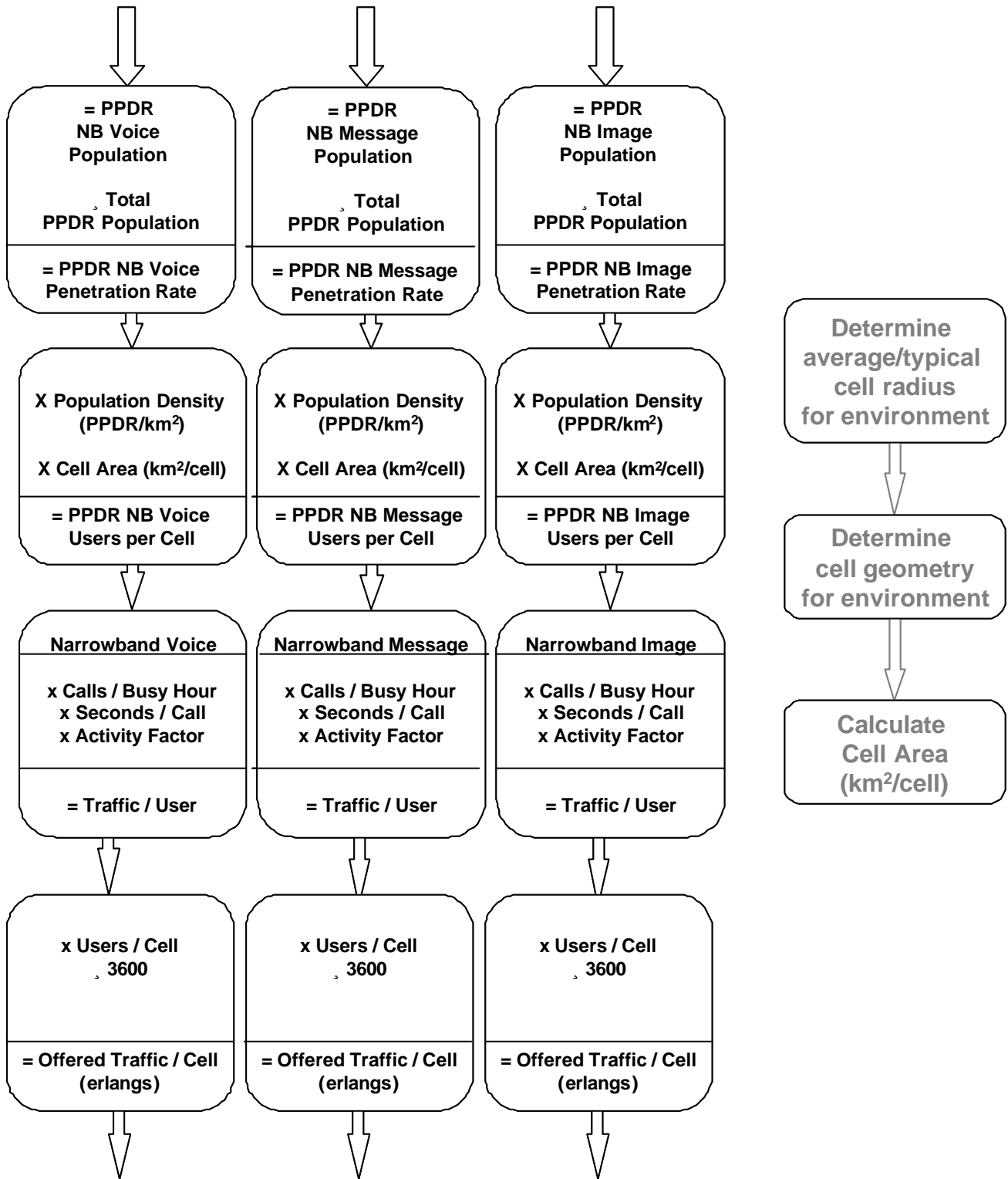

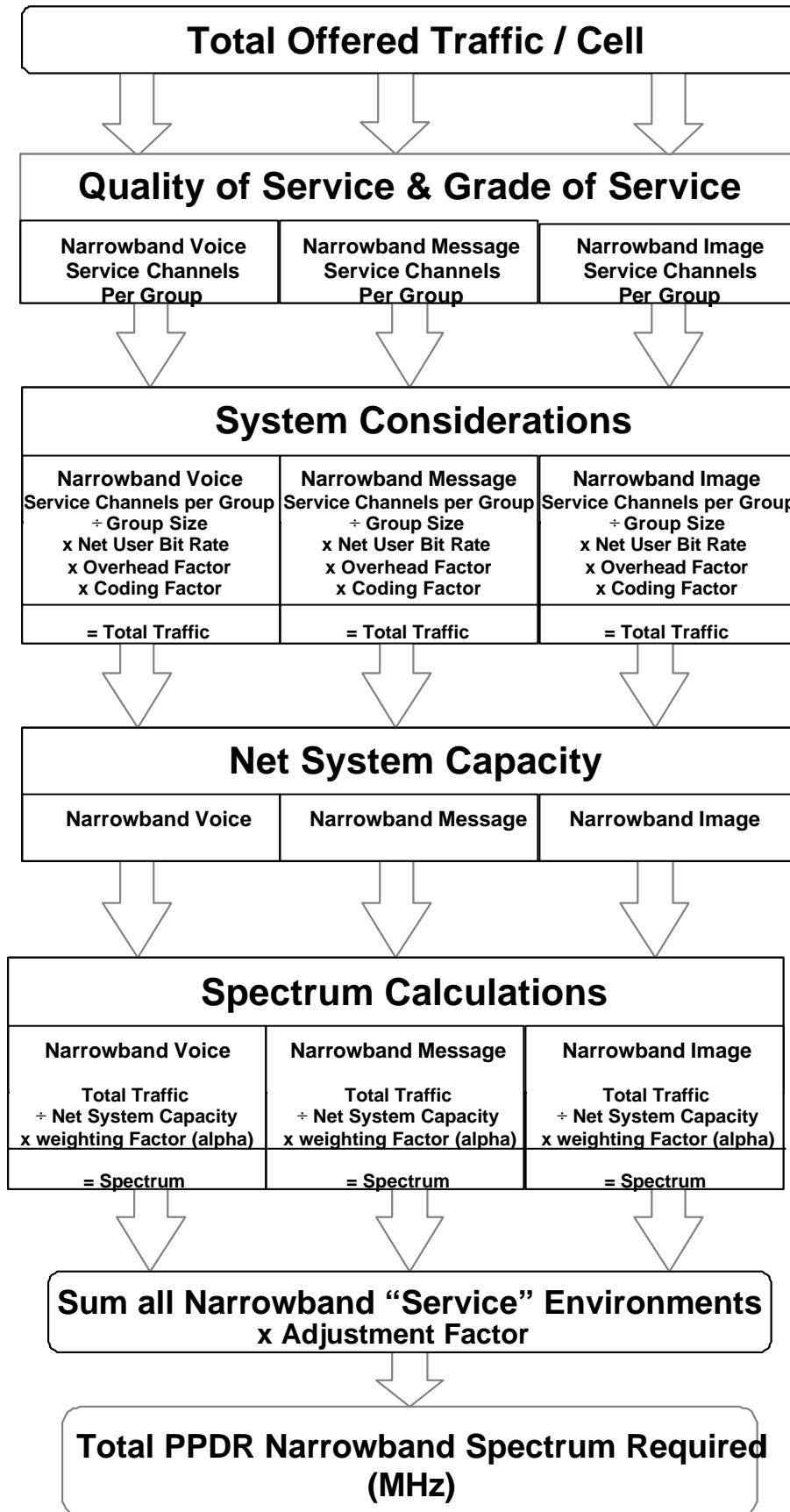

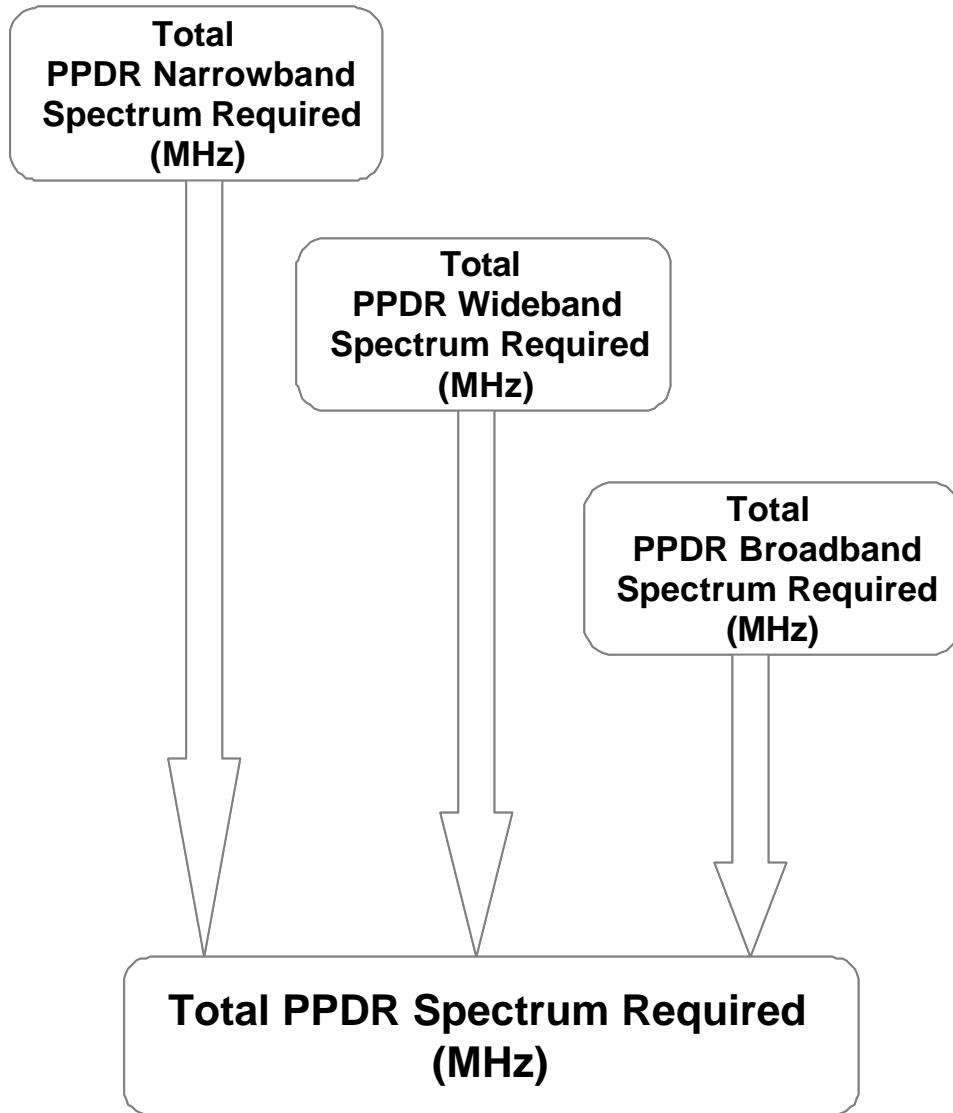

Appendix C

(to Attachment 1 to Annex 4)

System Capacity Calculation Examples

IMT-2000 Net System Capacity Calculation Methodology

The spectrum efficiency factor is an important measure of the capacity of a wireless telecommunications system. In order compare spectrum efficiency factors it is necessary to use a common basis to calculate the system capacity, in kbit/sec/MHz/cell, available to carry traffic. Analysis should take into consideration factors which reduce capacity over the air interface (guard bands, co-channel and adjacent channel interference, channels assigned to other purposes within the band). This calculation should produce the maximum system capacity possible within the spectrum band being studied. Actual systems will be sized for lower traffic levels to achieve the desired grade of service.

Annex 3 of the SAG Report on UMTS/IMT2000 Spectrum³ calculates the capacity of a generalized GSM network as:

C4 & C5 Net System Capability Calculation

GSM & IMT-2000			
width of band (MHz)	5.8	11.6	MHz total
width of channel	0.2		MHz
		29.0	FDD channels within band
re-use group factor	9		
		3.2	channels per cell
guard channels	2		(at band edge)
I/O channels	0		
		27.0	traffic channels
traffic/channel	8		8 TDMA slots per channel
data/channel	13		kbits/slot
overhead & signalling	1.75		(182 kbps per channel total)
		546.0	kb/sec/cell
		5.8	MHz bandwidth on outbound or inbound channel
			Total capacity available
		94.1	kbit/sec/cell/MHz on outbound or inbound channel
speech improvement	1.05	98.8	kbit/sec/cell/MHz on in- or outbound channel w/ speech improvement
all improvements	1.1	103.6	kbit/sec/cell/MHz on outbound or inbound channel w/ all improvements

The GSM Net System Capacity is usually rounded to 0.10 Mbit/sec/MHz/cell for use in IMT-2000 calculations.

³ UMTS Auction Consultative Group, A note on spectrum efficiency factors – UACG(98) 23. (<http://www.spectrumbauctions.gov.uk/documents/uacg23.html>) Reference 1 = SAG Report, Spectrum calculations for terrestrial UMTS, release 1.2, 12 March 1998.

The same methodology is applied below to several example narrowband technologies and several sample spectrum bands. The examples show that the spectrum band structure and frequency reuse factor have a significant effect on the capacity calculation.

These are not meant to be a direct comparison between the selected technologies. There are numerous other user needs and spectrum allocation factors that effect the functional and operational deployment of a network, the choice of technology, and overall network efficiency. Some of the spectrum factors are considered in the alpha and beta factors (M.1390 D5 and D6).

Net System Capability Summary			
Spectrum Band	Technology	Channels	Total Capacity Available
Re-use group factor = 12			
United States 821-824/866-869 MHz Band	P25 Phase I FDMA	1 x 12.5 kHz	60.0 kbit/sec/MHz/cell
United States 700 MHz Public Safety Band	P25 Phase I FDMA	1 x 12.5 kHz	53.9 kbit/sec/MHz/cell
United States 700 MHz Public Safety Band	P25 Phase II FDMA	1 x 6.25 kHz	107.7 kbit/sec/MHz/cell
European 400 MHz Public Safety Band	TETRA TDMA	4 slots/25 kHz	98.0 kbit/sec/MHz/cell
Re-use group factor = 21			
United States 821-824/866-869 MHz Band	P25 Phase I FDMA	1 x 12.5 kHz	34.3 kbit/sec/MHz/cell
United States 700 MHz Public Safety Band	P25 Phase I FDMA	1 x 12.5 kHz	30.8 kbit/sec/MHz/cell
United States 700 MHz Public Safety Band	P25 Phase II FDMA	1 x 6.25 kHz	61.6 kbit/sec/MHz/cell
European 400 MHz Public Safety Band	TETRA TDMA	4 slots/25 kHz	56.0 kbit/sec/MHz/cell

NOTE - Reuse group factor of 12 is used for systems implementing only low power, handheld, portable devices. Reuse factor of 21 is used for systems implementing both handheld portables and higher power, vehicular mounted, mobile devices. Greater reuse factor is required because of potential for interference from distant mobiles into cells designed for portable coverage.

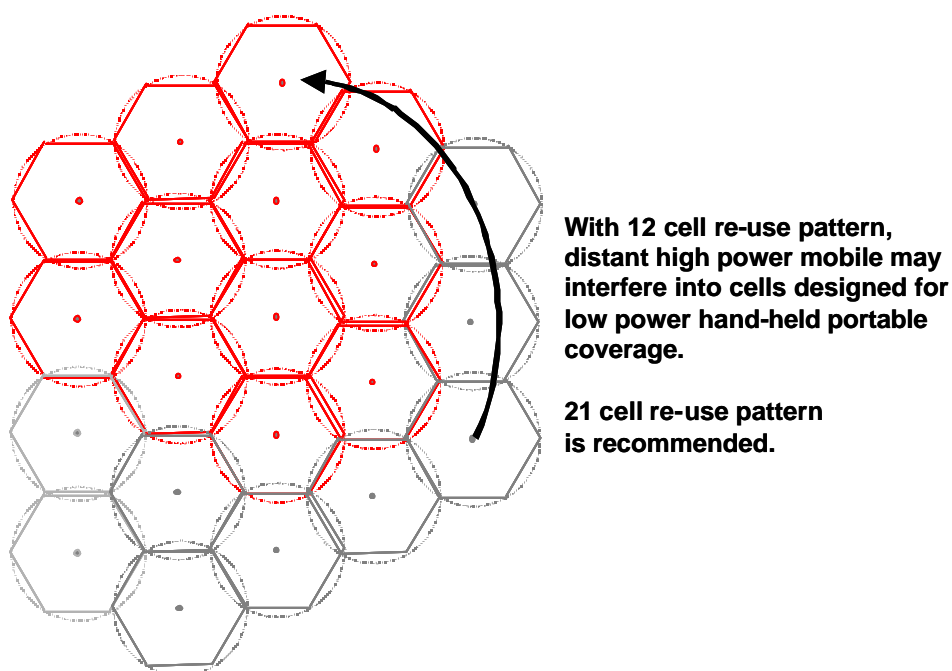

Example 1: Narrowband technologies for dispatch voice and low rate data.

Project 25 Phase I, FDMA applied to US 800 MHz Public Safety band.

C4 & C5 Net System Capability Calculation

NPSPAC using P25 Phase I FDMA		United States 821-824/866-869 MHz band	
width of band (MHz)	3	6.0	MHz total
width of channel	0.0125		
		240.0	FDD channels within band
re-use group factor	12		(portables only)
		20.0	channels per cell
guard channels	0		(at band edge)
I/O channels	15		(5 x 12.5 plus 12.5 kHz guard on each side of I/O channel)
		225.0	traffic channels
traffic/channel	1		
data/channel	4.8		kbps
overhead & signalling	2		(9.6 kbps per channel total)
		180.0	kb/sec/cell
		3.0	MHz bandwidth on outbound or inbound channel
			Total capacity available
		60.0	kbit/sec/cell/MHz on outbound or inbound channel
speech improvement	1.05	63.0	kbit/sec/cell/MHz on outbound or inbound channel w/ speech improvement
all improvements	1.1	66.0	kbit/sec/cell/MHz on outbound or inbound channel w/ all improvements

NPSPAC using P25 Phase I FDMA		United States 821-824/866-869 MHz band	
width of band (MHz)	3	6.0	MHz total
width of channel	0.0125		
		240.0	FDD channels within band
re-use group factor	21		(portables and mobiles)
		11.4	channels per cell
guard channels	0		(at band edge)
I/O channels	15		(5 x 12.5 plus 12.5 kHz guard on each side of I/O channel)
		225.0	traffic channels
traffic/channel	1		
data/channel	4.8		kbps
overhead & signalling	2		(9.6 kbps per channel total)
		102.9	kb/sec/cell
		3.0	MHz bandwidth on outbound or inbound channel
			Total capacity available
		34.3	kbit/sec/cell/MHz on outbound or inbound channel
speech improvement	1.05	36.0	kbit/sec/cell/MHz on outbound or inbound channel w/ speech improvement
all improvements	1.1	37.7	kbit/sec/cell/MHz on outbound or inbound channel w/ all improvements

Example 2: Narrowband technologies for dispatch voice and low rate data.
Project 25 Phase I, FDMA applied to US 700 MHz Public Safety band.

C4 & C5 Net System Capability Calculation

P25 Phase I FDMA		United States 700 MHz Public Safety Band	
width of band (MHz)	6	12.0	MHz total (4 x 3 Mhz blocks)
width of channel	0.0125		
		480.0	FDD channels within band
re-use group factor	12		(portables only)
		40.0	channels per cell
guard channels	12		(low power channels at band edge)
I/O channels	64		(32 x 12.5 kHz I/O plus 32 x 12.5 kHz reserve)
		404.0	traffic channels
traffic/channel	1		
data/channel	4.8		kbps
overhead & signalling	2		(9.6 kbps per channel total)
		323.2	kb/sec/cell
		6.0	MHz bandwidth on outbound or inbound chagnnel
			Total capacity available
		53.9	kbit/sec/cell/MHz on outbound or inbound channel
speech improvement	1.05	56.6	kbit/sec/cell/MHz on outbound or inbound channel w/ speech improvement
all improvements	1.1	59.3	kbit/sec/cell/MHz on outbound or inbound channel w/ all improvements

P25 Phase I FDMA		United States 700 MHz Public Safety Band	
width of band (MHz)	6	12.0	MHz total (4 x 3 Mhz blocks)
width of channel	0.0125		
		480.0	FDD channels within band
re-use group factor	21		(portables & mobiles)
		22.9	channels per cell
guard channels	12		(low power channels at band edge)
I/O channels	64		(32 x 12.5 kHz I/O plus 32 x 12.5 kHz reserve)
		404.0	traffic channels
traffic/channel	1		
data/channel	4.8		kbps
overhead & signalling	2		(9.6 kbps per channel total)
		184.7	kb/sec/cell
		6.0	MHz bandwidth on outbound or inbound chagnnel
			Total capacity available
		30.8	kbit/sec/cell/MHz on outbound or inbound channel
speech improvement	1.05	32.3	kbit/sec/cell/MHz on outbound or inbound channel w/ speech improvement
all improvements	1.1	33.9	kbit/sec/cell/MHz on outbound or inbound channel w/ all improvements

Example 3: Narrowband technologies for dispatch voice and low rate data.
Project 25 Phase II, FDMA applied to US 700 MHz Public Safety band.

C4 & C5 Net System Capability Calculation

P25 Phase II FDMA			United States 700 MHz Public Safety Band
width of band (MHz)	6	12.0	MHz total
width of channel	0.00625		
		960.0	FDD channels within band
re-use group factor	12		(portables only)
		80.0	channels per cell
guard channels	24		(low power channels at band edge)
I/O channels	128		(64 x 6.25 kHz I/O plus 64 x 6.25 kHz reserve)
		808.0	traffic channels
traffic/channel	1		
data/channel	4.8		kbps
overhead & signalling	2		(9.6 kbps per channel total)
		646.4	kb/sec/cell
		6.0	MHz bandwidth on outbound or inbound channel
			Total capacity available
		107.7	kbit/sec/cell/MHz on outbound or inbound channel
speech improvement	1.05	113.1	kbit/sec/cell/MHz on outbound or inbound channel w/ speech improvement
all improvements	1.1	118.5	kbit/sec/cell/MHz on outbound or inbound channel w/ all improvements

P25 Phase II FDMA			United States 700 MHz Public Safety Band
width of band (MHz)	6	12.0	MHz total
width of channel	0.00625		
		960.0	FDD channels within band
re-use group factor	21		(portables & mobiles)
		45.7	channels per cell
guard channels	24		(low power channels at band edge)
I/O channels	128		(64 x 6.25 kHz I/O plus 64 x 6.25 kHz reserve)
		808.0	traffic channels
traffic/channel	1		
data/channel	4.8		kbps
overhead & signalling	2		(9.6 kbps per channel total)
		369.4	kb/sec/cell
		6.0	MHz bandwidth on outbound or inbound channel
			Total capacity available
		61.6	kbit/sec/cell/MHz on outbound or inbound channel
speech improvement	1.05	64.6	kbit/sec/cell/MHz on outbound or inbound channel w/ speech improvement
all improvements	1.1	67.7	kbit/sec/cell/MHz on outbound or inbound channel w/ all improvements

Example 4: Narrowband technologies for dispatch voice and low rate data.
TETRA TDMA applied to European 400 MHz Public Safety band.

C4 & C5 Net System Capability Calculation

TETRA TDMA			European 400 MHz Public Safety Band
width of band (MHz)	3	6.0	MHz total
width of channel	0.025		
		120.0	FDD channels within band
re-use group factor	12		(hand-held portables only)
		10.0	channels per cell
guard channels	2		(at band edge)
Interoperability channel	20		(reserve for direct mode operations)
		98.0	traffic channels
traffic/channel	4		slots/channel
data/channel	7.2		kbps/slot
overhead & signalling	1.25		(36 kbps per channel total)
		294.0	kb/sec/cell
		3.0	MHz bandwidth on outbound or inbound channel
		Total capacity available	
		98.0	kbit/sec/MHz/cell on outbound or inbound channel
speech improvement	1.05	102.9	kbit/sec/MHz/cell on outbound or inbound channel w/ speech improvement
all improvements	1.1	107.8	kbit/sec/MHz/cell on outbound or inbound channel w/ all improvements

TETRA TDMA			European 400 MHz Public Safety Band
width of band (MHz)	3	6.0	MHz total
width of channel	0.025		
		120.0	FDD channels within band
re-use group factor	21		(mixture of portables & mobiles)
		5.7	channels per cell
guard channels	2		(at band edge)
Interoperability channel	20		(reserve for direct mode operations)
		98.0	traffic channels
traffic/channel	4		slots/channel
data/channel	7.2		kbps/slot
overhead & signalling	1.25		(36 kbps per channel total)
		168.0	kb/sec/cell
		3.0	MHz bandwidth on outbound or inbound channel
		Total capacity available	
		56.0	kbit/sec/MHz/cell on outbound or inbound channel
speech improvement	1.05	58.8	kbit/sec/MHz/cell on outbound or inbound channel w/ speech improvement
all improvements	1.1	61.6	kbit/sec/MHz/cell on outbound or inbound channel w/ all improvements

Example 5: Wideband technologies for data and low rate video.

Technology capable of meeting requirement of US 700 MHz Public Safety band for 384 kbit/s within 150 kHz channel bandwidth.

C4 & C5 Net System Capability Calculation

384 kbps / 150 kHz Estimate		
width of band (MHz)	4.8	9.6 MHz total
width of channel	0.15	MHz
		32.0 FDD channels within band
re-use group factor	12	
		2.7 channels per cell
guard channels	4	(at band edge)
I/O channels	12	
		16.0 traffic channels
traffic/channel	1	slots per channel
data/channel	192	kbps/slot
overhead & signalling	2	(192 kbps per channel total)
		512.0 kb/sec/cell
		4.8 MHz bandwidth on outbound or inbound channel
		Total capacity available
		106.7 kbit/sec/cell/MHz on outbound or inbound channel
speech improvement	1.05	112.0 kbit/sec/cell/MHz on in- or outbound channel w/ speech improvement
all improvements	1.1	117.3 kbit/sec/cell/MHz on outbound or inbound channel w/ all improvements

Data - assume 3/4 coding or 144 kbps source data, 48 kbps FEC, 192 kbps overhead

Video - assume 1/2 coding or for medium quality full motion video at 10 frames/sec

~ 50 kbps for video & 4.8 kbps for voice channel, 55 kbps FEC, 110 kbps overhead

Appendix D

(to Attachment 1 to Annex 4)

Example: Public Safety and Disaster Relief Population Density Data

England and Wales

Population = ~ 52.2 million England = ~ 49.23 million

Wales = ~ 2.95 million

Land Area = ~151 000 km² England = ~ 130 360 km²

Wales = ~ 20 760 km²

England Population density = 346 pop/km² = 100 000 pop/289 km²

London population = 7 285 000 people

London area = 1 620 km²

London population density = 4 496 pop/ km² = 100 000 pop/ 22.24 km²

Police Officer Strength⁴

	Total	Density/100 000
Police Officers (ordinary duty)	123 841	237.2
Police Officers (secondary assignments)	2 255	4.3
Police Officers (outside assignments)	702	1.3
	-----	-----
Total	126 798	242.9

Full Time Civilian Staff⁵

Full Time	48 759	93.4
Part Time Equivalent (7 897 staff)	4 272	8.2
	-----	-----
Total	53 031	101.6

Average Densities (Ordinary Officers)

Average = 237.2 officers per 100 000 population

Urban = 299.7

Non-urban = 201.2

8 largest metro = 352.4

Lowest Rural = 176.4

Officer/Civilian = 126 798/53 031 = 2.4 officers/civilian staff

⁴ Source: Police Service Personnel, England and Wales, as of 31 March 1999, by Julian Prime and Rohith Sen-gupta @ Home Office, Research Development & Statistics Directorate.

⁵ Includes NCS & NCIS civilian staffing.

Police Officer Distribution by Rank

Chief Constable	49	0.04%
Asst Chief Constable	151	0.12%
Superintendent	1 213	0.98%
Chief Inspector	1 604	1.30%
Inspector	5 936	4.80%
Sergeant	18 738	15.1%
Constable	96 150	77.6%

Other⁶

Special Constables	16 484
Traffic Wardens	3 342 full time equivalents
	(3 206 full-time and 242 part-time)

Fire Brigade

Staffing in England and Wales (43 brigades)

Paid	35 417
Retained (part-time or volunteer)	14 600

	50 082

London assume $126\,798/35\,417 = 3.58$ police/fire
Or about 98 fire/100 000 population in London

Fire Radio Inventory ~24 500 radios

50% penetration of radios into total

70% penetration of full time fire fighters

London PPDR Estimates

PPDR Category	PPDR Population	PPDR Penetration Rate for Narrowband Voice
Police	25 498	100%
Other Police Functions	6 010	10%
Police Civilian Support	13 987	10% (dispatchers, technicians, etc.)
Fire Brigade	7 081	70%
Part-time Fire	2 127	10%
Fire Civilian Support	----	0%
Emergency Medical	----	0%
EMS Civilian Support	----	0%
General Government	----	0%
Other PPDR Users	----	0%

⁶ Not included in totals above.

Appendix E
(to Attachment 1 to Annex 4)

Example Calculation

IMT-2000 methodology [Rec. ITU-R M.1390]		London TETRA Narrowband Voice Service		
A	Geographic Considerations			
A1	Select operational environment type Each environment type basically forms a column in calculation spreadsheet. Do not have to consider all environments, only the most significant contributors to spectrum requirements. Environments may geographically overlap. No user should occupy any two operational environments at one time.	Environment = "e" Combination of user density and user mobility: Density = dense urban, urban, suburban, rural Mobility = in-building, pedestrian, vehicular. Determine which of the possible density/mobility environments co-exist AND create greatest spectrum demand	urban pedestrian & mobile	urban pedestrian & mobile
A2	Select direction of calculation, uplink vs downlink, or combined	Usually separate calculations for up-link and down-link due to asymmetry in some services	uplink	downlink
A3	Representative cell area and geometry for each operational environment type	Average/typical cell geometry (in meters): radius for omnidirectional cells; radius of vertex for sectored hexagonal cells	5	
A4	Calculate representative cell area	Omni cells: circular = $\pi \times R^2$; hexagonal = $2.6 \times R^2$; Hex 3-sector = $2.6 \times R^2 / 3$ in km^2	65	

B	Market & Traffic Considerations				
B1	Telecommunication Services Offered:	Corresponding Net User Bit Rate (kbit/s)		7.2 kbps = 4.8kbps Vocoded Voice, plus 2.4kbps FEC	
B2	Population Density	total population = sum(pop by category)		54703	Total PPDR Population within area under consideration
				Population (POP) by PPDR Category	Penetration Rate (PEN) within PPDR Category (narrowband voice)
			Police	25498	1.00
			Other Police	6010	0.10
			Police Civilian support	13987	0.10
			Fire	7081	0.70
			Part-time Fire	2127	0.10
			Fire Civilian Support	0	0.10
			EMS	0	0.50
			EMS Civilian Support	0	0.10
			General Gov't	0	0.10
			Other PPDR users	0	0.10
		= SUM(POP x PEN)		32667.1	PPDR Population using NB Voice Service
		Area under consideration	308.9 sq mi	1620	km²
	Number of persons per unit of area within the environment under consideration. Population density may vary with mobility	potential user per km2		33.8	total pop / km²

B3	Penetration Rate				
	Percentage of persons subscribing to a service within an environment. Person may subscribe to more than one service, therefore, total penetration rate of all services within environment can exceed 100%				
			$= \frac{\text{PEN into PPDR category times PPDR category pop}}{\text{total PPDR pop}}$	by category $(\text{Police} = \text{Police PEN} \times \text{Police POP})$	by category $(\text{Police} = \text{Police PEN} \times \text{Police POP}) / \text{Total PPDR Pop}$
			Police 25498.00 Other Police 601.00 Police Civilian support 1398.70 Fire 4956.70 Part-time Fire 212.70 Fire Civilian Support 0.00 EMS 0.00 EMS Civilian Support 0.00 General Gov't 0.00 other PPDR users 0.00	25498.00 601.00 1398.70 4956.70 212.70 0.00 0.00 0.00 0.00	0.466 0.011 0.026 0.091 0.004 0.000 0.000 0.000 0.000
		= % of Total PPDR POP	Total PPDR penetration	59.717	% using NB voice
B4	Users/Cell Represents the number of people actually subscribing to the service "s" within a cell in environment "e"	$\text{Users/Cell} = \text{PopDensity} \times \text{PenRate} \times \text{CellArea}$ Dependent upon population density, cell area, and service penetration rate in each environment			PPDR NB voice users per cell
				1311	

B5	Traffic Parameters			uplink	downlink
	Busy Hour Call Attempts (BCHA)	calls/busy hour	From PSWAC	0.0073284 erlangs per busy hour	0.0463105 erlangs per busy hour
	Average number of calls/sessions attempted to/from average user during busy hour		Per PPDR NB Voice User	3.535	6.283
	Effective Call Duration Average call/session duration during busy hour	seconds/call	Per PPDR NB Voice User	7.88069024	26.53474455
	Activity Factor Percentage of time that resource is actually used during a conversation/session. Packet data may be bursty and resource is only used small percentage of time that session is active. If voice is only transmitted when user speaks, it does not tie up resource during pauses in speech or when listening.	Dispatch voice - each conversation ties up both sides of duplex channel	Per PPDR NB Voice User	1	1
B6	Traffic/User Average traffic in call-seconds generated by each user during busy hour	call-seconds per user = BusyHourAttempts x CallDuration x Activity	PPDR NB Voice Traffic/User	27.9	166.7
B7	Offered Traffic/Cell Average traffic generated by all users within a cell during the busy hour (3600 seconds)	Erlangs = Traffic/User x User/Cell / 3600	PPDR NB Voice Traffic/Cell	10.14	60.70

B8	Establish Quality of Service Function (QOS) Parameters			uplink	downlink
	<p>Group Size</p> <p>Number of cells in a group. Because cellular system deployment and technologies provide some measure of traffic 'sharing' between adjacent cells, traffic versus Quality of Service is considered within a grouping of cells.</p>	<p>12 (portable only) or 21 (portable + mobile)</p> <p>Typical cellular grouping is 1 cell surrounded by 6 adjacent cells for a Group Size of 7. Traffic/Cell is multiplied by Group Size and Quality of Service (or Blocking Function) is applied to grouping. Answer is divided by group size to restore to valuation per cell.</p>		21	21
	Traffic per group	= Traffic/Cell (in Erlangs) * Group size	PPDR NB Voice Traffic per group	213.00	1274.70
	<p>Service Channels per group</p> <p>Determine number of channels required to support traffic from each service, round to next higher whole number.</p>	<p>= apply Grade of Service formulas across group</p> <p>Circuit = Erlang B w/ 1% blocking. Used Erlang = 1.5, assuming that dispatch voice in broken into multiple systems with no more than 20 channels per site.</p>		1.50	1.50
			PPDR NB Voice service channels per group	319.50	1912.05

C Technical & System Considerations					
C1	Service Channels per Cell needed to carry offered load Actual number of 'channels' that must be provisioned within each cell to carry intended traffic	= Service Channels per Group / Group Size	PPDR NB Voice service channels per cell	uplink 15.21	downlink 91.05
C2	Service Channel Bit Rate (kilobits/sec) Service channel bit rate equals net user bit rate, plus any additional increases in bit rate due to coding factors and/or overhead signalling.	= Net User Bit Rate x Overhead Factor x Coding Factor This is where coding and overhead factors are included. For coding factor = 1, and overhead factor = 1, = B1 x 1 x 1 or = Net User Bit Rate	9.6 kb/s includes coding & overhead PPDR NB Voice service channel bit rate	9	9
C3	Calculate Traffic (Mb/s) Total traffic to be transmitted within the area of study - includes all factors; user traffic (call duration, busy hour call attempts, activity factor, net channel bit rate), environment, service type, direction of transmission (up/down link), cell geometry, quality of service, traffic efficiency (calculated across a group of cells), and service channel bit rate (including coding and overhead factors)	= Service Channels / Cell x Service Channel Bit Rate	PPDR NB Voice Traffic (Mb/s)	0.137	0.819

C4	<p>Net System Capability Measure of system capacity for a specific technology. Related to spectral efficiency. Requires complex calculation or simulation to determine Net System Capability for a specific technology deployed in a specific network configuration.</p>	<p>Trade-offs between Net System Capability and Quality of Service. May include the following factors; spectral efficiency of technology, Eb/No requirements, C/I requirements, Frequency re-use plan, coding/signalling factors of radio transmission technology, environment, deployment model.</p>			
C5	<p>Calculate for GSM model</p>	<p>Calculation for TETRA TDMA using 25 kHz bandwidth channels, 21 cell re-use (mobile + portable), 4 traffic slots per carrier, ignoring signalling channels, 400 MHz bandplan, FDD w/ 2 x 3 MHz (120 RF channels - 20 DMO channels - 2 guard channels at edge of band), data rate of 7.2 kilobits/sec on each traffic slot, a factor of 1.25 for overhead and coding. Net System Capacity for TETRA TDMA = 56.0 kb/s/MHz/cell</p>	<p>TETRA</p>	<p>0.056</p>	<p>0.056</p>

D	Spectrum Results				
D1-D4	Calculate individual components	Freq = Traffic / Net System Capability	PPDR NB Voice (MHz)	uplink 2.445	downlink 14.633
D5	Weighting Factor for each environment (alpha) weighting of each environment relative to other environments - alpha may vary from 0 to 1, correct for non-simultaneous busy hours, correct for geographic offsets	= Freq x alpha If all environments have coincident Busy Hours and all three environments are co-located, then alpha = 1	alpha = 1 PPDR NB Voice (MHz)	1 2.445	1 14.633
D6	Adjustment Factor (beta)	Freq(total) = beta x sum(alpha x Freq)			
	Adjustment of all environments to outside effects - multiple operators/users (decreased trunking or spectral efficiency), guard bands, sharing with other services within band, technology modularity, etc	For Dispatch Voice model, assuming one system and fact that guard bands were included in C5, then beta = 1. Multiple systems, such as one for Police and one for Fire/EMS may decrease efficiency and beta would be > 1.	beta = 1	1	
D7	Calculate total spectrum		PPDR NB Voice TOTAL (MHz)	17.078 MHz	

Appendix F

(to Attachment 1 to Annex 4)

Example Narrowband and Wideband Calculation Summaries

Narrowband PPDR Category	London Users	Penetration Rates		
		NB Voice	NB Message	NB Image
Police	25498	1.00	0.5	0.25
Other Police	6010	0.10	0.05	0.025
Police Civilian support	13987	0.10	0.05	0.025
Fire	7081	0.70	0.35	0.175
Part-time Fire	2127	0.10	0.05	0.025
Fire Civilian Support	0	0.10	0.05	0.025
EMS	0	0.50	0.25	0.125
EMS Civilian Support	0	0.10	0.05	0.025
General Gov't	0	0.10	0.05	0.025
Other PPDR users	0	0.10	0.05	0.025
Total PPDR Users	54703	32667	16334	8167
Spectrum by 'Service Environment' (MHz)		17.1	1.4	4.2
Narrowband Spectrum	22.7	MHz		

Other Parameters:			
Environment	urban pedestrian & mobile		
Cell Radius (km)	5		
Study Area (km ²)	1620		
Cell Area (km ²)	65	(calculated)	
Cells per Study Area	25	(calculated)	
Net User Bit Rate	9 kbps (7.2 kbps per slot + 1.8 kbps channel overhead) = 4.8 kbps speech, data, or image per slot + 2.4 kbps forward error correction per slot + 1.8 kbps channel overhead and signalling		
		NB Voice	NB Data
		uplink	uplink
Erlangs per Busy Hour	(From PSWAC)	0.0077384	0.0030201
Busy Hour Call Attempts		3.54	5.18
Effective Call Duration		7.88	2.10
Activity Factor		1	1
		downlink	downlink
Erlangs per Busy Hour	(From PSWAC)	0.0463105	0.0057000
Busy Hour Call Attempts		6.28	5.18
Effective Call Duration		26.53	3.96
Activity Factor		1	1
Group Size	21		
Grade of Service Factor	1.50		
Net System Capacity	0.0560	kbps/MHz/cell	
Alpha Factor	1		
Beta Factor	1		

London Narrowband Voice, Message, and Image

Narrowband PPDR Category	New York City Users	Penetration Rates		
		NB Voice	NB Message	NB Image
Police	39286	0.70	0.35	0.175
Other Police	0	0.10	0.05	0.025
Police Civilian support	8408	0.10	0.05	0.025
Fire	11653	0.70	0.35	0.175
Part-time Fire	0	0.10	0.05	0.025
Fire Civilian Support	4404	0.10	0.05	0.025
EMS	0	0.50	0.25	0.125
EMS Civilian Support	0	0.10	0.05	0.025
General Gov't	21217	0.10	0.05	0.025
Other PPDR users	3409	0.10	0.05	0.025
Total PPDR Users	88377	39401	19701	9850
Spectrum by 'Service Environment' (MHz)		51.8	4.2	20.0
Narrowband Spectrum	76.0	MHz		

Other Parameters:				
Environment	urban pedestrian & mobile			
Cell Radius (km)	4			
Study Area (km ²)	800			
Cell Area (km ²)	41.6	(calculated)		
Cells per Study Area	19	(calculated)		
Net User Bit Rate	9.6 kbps			
	= 4.8 kbps speech, data, or image			
	+ 2.4 kbps forward error correction			
	+ 2.4 kbps overhead and signalling			
		NB Voice	NB Data	NB Image
		uplink	uplink	uplink
Erlangs per Busy Hour (From PSWAC)		0.0077384	0.0030201	0.0268314
Busy Hour Call Attempts		3.54	5.18	3.00
Effective Call Duration		7.88	2.10	32.20
Activity Factor		1	1	1
		downlink	downlink	downlink
Erlangs per Busy Hour (From PSWAC)		0.0463105	0.0057000	0.0266667
Busy Hour Call Attempts		6.28	5.18	3.00
Effective Call Duration		26.53	3.96	32.00
Activity Factor		1	1	1
Group Size	21			
Grade of Service Factor	1.50			
Net System Capacity	0.0308	kbps/MHz/cell		
Alpha Factor	1			
Beta Factor	1			

New York City Narrowband Voice, Message, and Image

New York City Wideband Data and Video

Wideband PPDR Category	New York City Users	Penetration Rates		
		WB Data	WB Video	
Police	39286	0.23	0.14	
Other Police	0	0.01	0.01	
Police Civilian support	8408	0.01	0.01	
Fire	11653	0.28	0.20	
Part-time Fire	0	0.01	0.01	
Fire Civilian Support	4404	0.01	0.01	
EMS	0	0.31	0.17	
EMS Civilian Support	0	0.01	0.01	
General Gov't	21217	0.01	0.03	
Other PPDR users	3409	0.01	0.01	
Total PPDR Users	88377	12673	8629	PPDR Users
Spectrum by 'Service Environment'		18.3	19.5	MHz
Wideband Spectrum	37.9	MHz		

Other Parameters:				
Environment	urban pedestrian & low power mobile			
Cell Radius (km)	3.0			
Study Area (km ²)	800			
Cell Area (km ²)	23.4	(calculated)		
Cells per Study Area	34	(calculated)		
Net User Bit Rate	Wideband Video	Wideband Data		
	(10 frames/sec)	384 kbps		
	220 kbps	= 144 kbps data		
	= 55 kbps video & voice	+ 48 kbps FEC		
	+ 55 kbps FEC	+ 192 kbps overhead		
	+ 110 bps overhead			
	uplink	uplink	downlink	
Erlangs per Busy Hour	0.0250	(calculated)	0.0008	0.0083
Busy Hour Call Attempts	3		3	3
Effective Call Duration	30	sec	1	10
Activity Factor	1		1	1
Group Size	12			
Grade of Service Factor	1.50			
Net System Capacity	0.1067	kbps/MHz/cell		
Alpha Factor	1			
Beta Factor	1			

Attachment 2

(to Annex 4)

PPDR spectrum calculation based on Generic City Analysis (Demographic population)

Generic City Approach

Instead of looking at specific cities, the following analysis examines several medium sized cities in several countries. This analysis is based upon the average density of police officers relative to the general demographic population and the ratio of police to other public protection providers. From this analysis, a generic example of the relationship between the different PPDR user categories and **demographic population** density has been developed. This approach shows the optimum PPDR spectrum requirement based on the size of demographic population, that is, the amount of PPDR spectrum requirement based on the idealistic amount of PPDR users in a city based on demographic population size.

The police and PPDR densities were examined from national statistics and city budgets for the United States, Canada, Australia, and England. Statistics for police show a national average density in the 180 police per 100 000 population to 250 police per 100 000 population. The density in urban areas varies from about 25% above the national average for medium density cities to >100% above the national average for dense urban cities. The density in suburban areas varies from about 25% above the national average for suburbs of medium density cities to 50% above the national average for suburbs of dense urban cities.

Fire & EMS/Rescue levels were harder to determine because they are often combined together. Information was used for cities where they were separate, and ratios of the various PP & DR categories were determined relative to the police population density. For example, ratios for fire fighters were in the range of 3.5 to 4 police officers per fire fighter (25 to 30%). Where Rescue/Emergency Medical/Ambulance could be separated out, ratios for Rescue/EMS were in the range of 3.5 to 4 fire fighters per Rescue/EMS (25 to 30%).

In the generic examples below, and for simplicity, only two densities are used, 180 and 250 police per 100 000 population. Also for simplicity, only two types of cities were analysed: a medium size city (2.5 million population) and a large city (8 million population). This probably under-estimates the PPDR density in large urban areas where there are many examples of police densities in the range of 400-500 police per 100 000 population.

The "doughnut" effect was also examined, where frequencies used in the urban center can not be reused in the suburbs immediately adjacent to the urban area. In ITU-R contributions from the 2000-2003 study period, many of the cities included both the urban and suburban areas together in a single spectrum requirement calculation. Cell size had to be averaged and PPDR user density was lowered. In retrospect, each area should have been treated separately, and the spectrum requirements added together.

Numerous urban areas were examined. Most had a central urban core with a dense population. There was also a suburban ring around the urban core that contained about the same amount of population, but was about 5 to 20 times the area of the urban core. The examples below use a ratio of 10:1 for suburban to urban area. Assuming 4 to 5 km radius cell sizes for the urban core, typical cell sizes in the suburbs should be about 10 times larger in area or ~3 times larger in radius.

Metropolitan Area Urban Core and Adjacent Suburbs

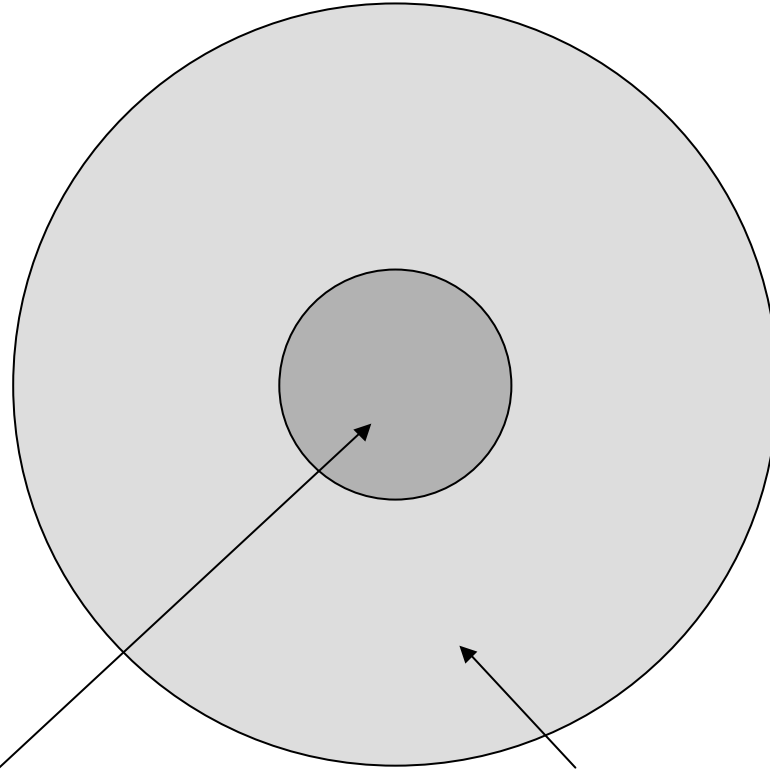

Urban Core

- Assume area in 500 to 1500 km² range
- Assume population in 2 to 8 million range
- Assume radius of narrowband cells to be in 4 to 5 km range

Adjacent Suburban Area

- Assume area is ~10x area of urban core
- Assume population approximately equal to population in urban core
- Assume radius of narrowband cells to be about 3 x radius (10x area) of cells in urban core

Frequency Re-use

- NB = little frequency re-use between urban core & surrounding suburbs due to re-use factor (21)
- WB = smaller radius cells & lower re-use factor (12)
- Allows re-use within the suburban ring and some
- re-use between urban core & suburban ring

PPDR categories

Three classes of users were defined, which is basically re-grouping the PPDR categories by penetration rates:

Primary users (usage @ 30% penetration rate) = PP users normally operating within the geographic area on a day-to-day basis = local police, fire fighters, and emergency medical/rescue

Secondary users (usage @ 10% penetration rate) = Other police (state, district, province, federal, national, special operations, investigators), part-time or volunteer police/fire, general government workers, civil protection agencies, military/army, utility workers, disaster relief workers

Support users (usage @ <10% penetration rate) = civilian support

Penetration rate & PPDR category data used to calculate spectrum requirements

Narrowband & Wideband CATEGORY name and number of USER's		Services Summary	NB Voice	NB Message	NB Status	WB Data	WB Video
User Category	Users						
			Penetration Rate Summary				
Primary - Local Police	5625		0.300	0.300	0.300	0.250	0.125
Secondary - Law Enforcement/Investigators	563		0.100	0.100	0.100	0.010	0.010
Secondary - Police Functions	0		0.100	0.100	0.100	0.010	0.010
Police Civilian Support	1125		0.100	0.000	0.000	0.010	0.010
Primary - Fire Fighters	1631		0.300	0.300	0.300	0.250	0.125
Fire Civilian Support	326		0.100	0.000	0.000	0.010	0.010
Primary - Rescue/Emergency Medical	489		0.300	0.300	0.300	0.250	0.125
Rescue/EMS Civilian Support	98		0.100	0.000	0.000	0.010	0.010
Secondary - General Gov't & Civil Agencies	563		0.100	0.100	0.100	0.010	0.010
Secondary - Volunteers & Other PPDR Users	281		0.100	0.100	0.100	0.010	0.010
Total Users	10701						

Primary users are the users that local Public Protection system would be designed to handle. A local system would be designed to handle "average busy hour" traffic plus a loading factor to be able to handle peak loads with a reasonable grade of service.

Part of the assumption is that many secondary users may have their own communications system and loading added to local Public Protection system is for coordination between the secondary users and the primary users.

Disaster scenario

Disaster occurs and personnel from surrounding areas, national government, and international agencies come to support the local agencies. There is immediate need for emergency workers to handle fires and to rescue injured people. Later arrivals are investigators and personnel to clean up the damage.

For disaster response - the following assumptions were made:

- Civilian support (<10% penetration rate): No increase in the number of civilian support workers for police/fire/EMS/rescue. The usage remains within the original system design parameters (30% penetration rate, 1.5 GoS peaking factor).
- Police: No increase in the number of local police. The usage remains within the original system design parameters (30% penetration rate, 1.5 GoS peaking factor).

- Other Police: Increase in personnel providing police functions equal to 30% of local police population, but at a lower secondary level (10% penetration rate). These are personnel who come from outside the area to supplement local police.
- Investigators and Law Enforcement: The population doubles as additional investigators move into the disaster area.
- Fire & EMS/Rescue: A 30% increase in the number of users. Users from surrounding areas immediately move into the disaster area and operate on the local system or set up additional communication systems. The need for communications is very great. Operate at primary level (30% penetration rate).
- Secondary level users (10% penetration rate): Double the number of general government users, volunteers, civil agency users, utility users, etc who need to communicate with primary users or need to use the local network for communications.

Where is the disaster?

Look at three disaster scenarios:

- 1) No disaster = normal day-to-day operations
- 2) Disaster only in urban area
- 3) Disaster only in suburban area

Spectrum requirements

Calculate spectrum requirements for:

- Urban day-to-day
- Urban disaster
- Suburban day-to-day
- Suburban disaster
- Spectrum requirements for the three disaster scenarios:

(Instead of worst case analysis)

Urban and Suburban systems designed to handle "average busy hour" traffic loading plus a 1.5 GoS factor to handle emergency loading by the normal PP & DR users. Disaster operations assumes that additional, outside PP & DR personnel are added to the system.

- 1) Normal Day-to-day operations:

The amount of spectrum required for NB equals the sum of the urban and suburban spectrum calculations. The assumption is that spectrum used in the urban area can not be reused in the adjacent suburban area, due to large cell size and large reuse factor.

The amount of spectrum required for WB equals the sum of the urban and 1/2 of the suburban spectrum calculation. The assumption is that spectrum used in the urban area can be reused in the adjacent suburban area, due to the smaller cell size and smaller reuse factor. Also, because the urban area sits in middle of the suburban area, there is some additional separation, which would allow additional frequency reuse between suburban sites.

- 2) Urban disaster operations:

The amount of spectrum required for NB equals the sum of the urban disaster and the suburban non-disaster spectrum calculation.

The amount of spectrum required for WB equals the sum of the urban disaster and 1/2 of the suburban non-disaster spectrum calculation.

3) Suburban disaster operations:

The amount of spectrum required for NB equals the sum of the urban non-disaster and the suburban disaster spectrum calculation.

The amount of spectrum required for WB equals the sum of the urban non-disaster and 1/2 of the suburban disaster spectrum calculation.

Medium Metropolitan Area

Calculated spectrum requirements using a PPDR calculator spreadsheet.

Medium Metropolitan Area (urban population = ~ 2.5 million and area = ~ 600 km ²) (suburban population = ~ 2.5 million and area = ~ 6000 km ²)			
Medium PPDR Density (180 Police per 100,000 pop)		High PPDR Density (250 Police per 100,000 pop)	
Urban		Urban	
NB Day-to-day	15.5 MHz	NB Day-to-day	21.5 MHz
WB Day-to-day	16.2 MHz	WB Day-to-day	22.6 MHz
Disaster NB	18.4 MHz	Disaster NB	25.6 MHz
Disaster WB	17.8 MHz	Disaster WB	24.7 MHz
Suburban		Suburban	
NB Day-to-day	12.9 MHz	NB Day-to-day	17.9 MHz
WB Day-to-day	13.5 MHz	WB Day-to-day	18.8 MHz
Disaster NB	15.4 MHz	Disaster NB	21.4 MHz
Disaster WB	14.8 MHz	Disaster WB	20.6 MHz
Normal Day-to-day		Normal Day-to-day	
NB (urban + suburban)	28.40 MHz	NB	39.40 MHz
WB (urban + 1/2 suburban)	<u>22.95</u> MHz	WB	<u>32.00</u> MHz
	51.35		71.40
Suburban Disaster		Suburban Disaster	
NB	30.90 MHz	NB	42.90 MHz
WB	<u>23.60</u> MHz	WB	<u>32.90</u> MHz
	54.50		75.80
Urban Disaster		Urban Disaster	
NB	31.30 MHz	NB	43.50 MHz
WB	<u>24.55</u> MHz	WB	<u>34.10</u> MHz
	55.85		77.60

The left-hand column shows the spectrum calculated for a medium PPDR user density and the right-hand column shows the spectrum calculated for a higher PPDR user density.

The top-half of the chart shows individual NB and WB spectrum calculations for normal "day-to-day" operations and for a disaster within the local area.

The total spectrum requirement is the sum of the urban and suburban calculations. For narrowband the assumption is that frequencies are not reused between the two areas, so the total is the sum of the NB urban and the NB suburban requirements. For wideband, the assumption is that some frequencies can be reused, therefore, the total is the sum of the wideband urban requirement and 1/2 of the wideband suburban requirement.

The bottom half of the chart shows the spectrum calculated for a disaster in either the urban area or the suburban area, where there is a significant increase in the number of users (up to 30% for primary users).

Normal day-to-day operations for this generic medium size city require from 51 MHz to 71 MHz depending on whether it is located in a country with a medium PPDR density or a high PPDR density.

If a disaster scenario described above occurs in the suburban area, then the NB/WB spectrum requirement increases by about 6%. If a disaster occurs in the urban area, then NB/WB spectrum requirement increases by about 9%.

Disaster operations for this generic medium size city require from 55 MHz to 78 MHz depending on where the disaster occurs and whether it is located in a country with a medium PPDR density or a high PPDR density.

The broadband spectrum requirement needs to be added. Since broadband will cover very small radius "hot spots", the broadband frequencies can be reused throughout the urban and suburban area. **ITU-R contributions from the 2000-2003 study period have shown broadband spectrum requirements to be in the 50-75 MHz range.**

Therefore, for a generic medium size city, the total spectrum requirement is in the range of 105 to 153 MHz to handle the type of disaster scenario described above.

The two tables below show the breakout of PPDR users and narrowband and wideband services in a medium-sized Metropolitan area.

Medium Metropolitan Area calculated for 180 police officers per 100 000 population

Spectrum Requirements - Generic City Calculator				Re-Formatted	July 2002				
Metropolitan Study Area		Medium Metropolitan Area		Input Data					
Population of Urban Area	2 500 000	people	1.0	Ratio Suburban/Urban Population					
Population of Surrounding Suburban Area	2 500 000	people		Ratio should be near 1.0 (Range of 0.5X to 1.5X of Urban Pop)					
Area of Urban Center	600	km ²	10.0	Ratio Suburban/Urban Area					
Area of Surrounding Suburbs	6 000	km ²		Ratio should be near 10.0 (Range of 5X to 15X of Urban Area)					
Urban Population Density	4 167	people/km ²							
Suburban Population Density	417	people/km ²							
"Large" or "Medium" City	MED	If Urban Population Density > 5 000 people/km ² , then this is a large city, OR If Urban Population > 3 000 000 people, then this is a large city, otherwise this is a							
Police User Density (national average)	180.0	police per 100,000 population							
CATEGORY name and number of USER's		Urban Day-to-Day	Urban Disaster	Suburb Day-to-Day	Suburban Disaster				
User Category		Population	Population	Population	Population				
Primary - Local Police		6750	6750	5625	5625				
Secondary - Law Enforcement/Investigators		675	1350	563	1125				
Secondary - Police Functions		0	2025	0	1688				
Police Civilian Support		1350	1350	1125	1125				
Primary - Fire Fighters		1958	2545	1631	2121				
Fire Civilian Support		392	392	326	326				
Primary - Rescue/Emergency Medical		587	763	489	636				
Rescue/EMS Civilian Support		117	117	98	98				
Secondary - General Gov't & Civil Agencies		675	1350	563	1125				
Secondary - Volunteers & Other PPDR Users		338	675	281	563				
Total		12841	17317	10701	14431				
Narrowband		Urban Day-to-Day	Urban Disaster	Suburb Day-to-Day	Suburban Disaster				
		Busy Hour Users	Spectrum Required (MHz)	Busy Hour Users	Spectrum Required (MHz)	Busy Hour Users	Spectrum Required (MHz)		
NB Voice Service		3143	13.8	3743	16.4	2619	11.5	3119	13.7
NB Message Service		2957	1.6	3557	1.9	2464	1.3	2965	1.6
NB Status Service		2957	0.1	3557	0.1	2464	0.1	2965	0.1
Total Narrowband Spectrum Required (MHz)			15.5		18.4		12.9		15.4
Normal NB Day-to-Day		28.4 MHz	15.5	<	<	<	12.9		
NB Urban Disaster Scenario		31.3 MHz	<	<	18.4	<	12.9		
NB Suburban Disaster Scenario		30.9 MHz	15.5	<	<	<	<	<	15.4
Larger of the two NB disaster scenarios		31.3 MHz							
Wideband		Urban Day-to-Day	Urban Disaster	Suburb Day-to-Day	Suburban Disaster				
		Busy Hour Users	Spectrum Required (MHz)	Busy Hour Users	Spectrum Required (MHz)	Busy Hour Users	Spectrum Required (MHz)		
WB Data Service		2359	15.7	2587	17.2	1966	13.1	2156	14.3
WB Video Service		1197	0.5	1330	0.6	998	0.4	1108	0.5
Total Wideband Spectrum Required (MHz)			16.2		17.8		13.5		14.8
Normal WB Day-to-Day		23.0 MHz	16.2	<	<	<	6.8		
Urban WB Disaster Scenario		24.6 MHz	<	<	17.8	<	6.8		
Suburban WB Disaster Scenario		23.6 MHz	16.2	<	<	<	<	<	7.4
Larger of the two WB disaster scenarios		24.6 MHz							
Spectrum Requirement Totals		NB	WB	Sum					
Normal Day-to-Day		28.4	23.0	=	51.4 MHz				
Suburban Disaster Scenario		30.9	23.6	=	54.5 MHz				
Urban Disaster Scenario		31.3	24.6	=	55.9 MHz				

Medium Metropolitan Area calculated for 250 police officers per 100 000 population

Spectrum Requirements - Generic City Calculator				Re-Formatted	July 2002			
Metropolitan Study Area		Medium Metropolitan Area		Input Data				
Population of Urban Area	2 500 000	people	1.0	Ratio Suburban/Urban Population				
Population of Surrounding Suburban Area	2 500 000	people		Ratio should be near 1.0 (Range of 0.5X to 1.5X of Urban Popu				
Area of Urban Center	600	km ²	10.0	Ratio Suburban/Urban Area				
Area of Surrounding Suburbs	6 000	km ²		Ratio should be near 10.0 (Range of 5X to 15X of Urban Area)				
Urban Population Density	4 167	people/km ²						
Suburban Population Density	417	people/km ²						
"Large" or "Medium" City	MED	If Urban Population Density > 5 000 people/km2, then this is a large city, OR If Urban Population > 3 000 000 people, then this is a large city, otherwise this is a						
Police User Density (national average)	250.0	police per 100,000 population						
CATEGORY name and number of USER's	Urban Day-to-Day		Urban Disaster		Suburb Day-to-Day		Suburban Disaster	
User Category	Population	Population	Population	Population	Population	Population	Population	
Primary - Local Police	9375	9375	7813	7813				
Secondary - Law Enforcement/Investigators	938	1875	1875	781			1563	
Secondary - Police Functions	0	2813	0				2344	
Police Civilian Support	1875	1875	1563	1563				
Primary - Fire Fighters	2719	3534	2266	2945				
Fire Civilian Support	544	544	453	453				
Primary - Rescue/Emergency Medical	816	1060	680	884				
Rescue/EMS Civilian Support	163	163	136	136				
Secondary - General Gov't & Civil Agencies	938	1875	781	1563				
Secondary - Volunteers & Other PPDR Users	469	938	391	781				
Total	17835	24052	14863	20043				
Narrowband	Urban Day-to-Day		Urban Disaster		Suburb Day-to-Day		Suburban Disaster	
	Busy Hour Users	Spectrum Required (MHz)	Busy Hour Users	Spectrum Required (MHz)	Busy Hour Users	Spectrum Required (MHz)	Busy Hour Users	Spectrum Required (MHz)
	NB Voice Service	4365 19.2	5199 22.8	3638 16.0	4333 19.1			
	NB Message Service	4107 2.2	4941 2.7	3423 1.9	4117 2.2			
	NB Status Service	4107 0.1	4941 0.1	3423 0.1	4117 0.1			
	Total Narrowband Spectrum Required (MHz)	21.5	25.6	17.9	21.4			
Normal NB Day-to-Day	39.4 MHz	21.5	<	<	<	17.9		
NB Urban Disaster Scenario	43.5 MHz	<	<	25.6	<	17.9		
NB Suburban Disaster Scenario	42.8 MHz	21.5	<	<	<	<	21.4	
Larger of the two NB disaster scenarios	43.5 MHz							
Wideband	Urban Day-to-Day		Urban Disaster		Suburb Day-to-Day		Suburban Disaster	
	Busy Hour Users	Spectrum Required (MHz)	Busy Hour Users	Spectrum Required (MHz)	Busy Hour Users	Spectrum Required (MHz)	Busy Hour Users	Spectrum Required (MHz)
	WB Data Service	3277 21.8	3593 23.9	2731 18.2	2994 19.9			
	WB Video Service	1663 0.7	1847 0.8	1386 0.6	1539 0.7			
	Total Wideband Spectrum Required (MHz)	22.5	24.7	18.8	20.6			
					x 1/2		x 1/2	
Normal WB Day-to-Day	31.9 MHz	22.5	<	<	<	9.4		
Urban WB Disaster Scenario	34.1 MHz	<	<	24.7	<	9.4		
Suburban WB Disaster Scenario	32.8 MHz	22.5	<	<	<	<	10.3	
Larger of the two WB disaster scenarios	34.1 MHz							
Spectrum Requirement Totals								
Normal Day-to-Day	NB	39.4	+	WB	31.9	=	Sum	71.3 MHz
Suburban Disaster Scenario		42.8	+		32.8	=		75.7 MHz
Urban Disaster Scenario		43.5	+		34.1	=		77.6 MHz

Large Metropolitan Area

Calculated spectrum requirements using a PPDR calculator spreadsheet.

Large Metropolitan Area (urban population = ~ 8.0 million and area = ~ 800 km ²) (suburban population = ~ 8.0 million and area = ~ 8000 km ²)			
Medium PPDR Density (180 Police per 100,000 pop)		High PPDR Density (250 Police per 100,000 pop)	
Urban		Urban	
NB Day-to-day	23.7 MHz	NB Day-to-day	33.0 MHz
WB Day-to-day	24.9 MHz	WB Day-to-day	34.6 MHz
Disaster NB	28.3 MHz	Disaster NB	39.3 MHz
Disaster WB	27.4 MHz	Disaster WB	38.0 MHz
Suburban		Suburban	
NB Day-to-day	19.8 MHz	NB Day-to-day	27.4 MHz
WB Day-to-day	20.7 MHz	WB Day-to-day	28.7 MHz
Disaster NB	23.6 MHz	Disaster NB	32.7 MHz
Disaster WB	22.7 MHz	Disaster WB	31.5 MHz
Normal Day-to-day		Normal Day-to-day	
NB (urban + suburban)	43.50 MHz	NB	60.40 MHz
WB (urban + 1/2 suburban)	<u>35.25</u> MHz	WB	<u>48.95</u> MHz
	78.75		109.35
Suburban Disaster		Suburban Disaster	
NB	47.30 MHz	NB	65.70 MHz
WB	<u>36.25</u> MHz	WB	<u>50.35</u> MHz
	83.55		116.05
Urban Disaster		Urban Disaster	
NB	48.10 MHz	NB	66.70 MHz
WB	<u>37.75</u> MHz	WB	<u>52.35</u> MHz
	85.85		119.05

The left-hand column shows the spectrum calculated for a medium PPDR user density and the right-hand column shows the spectrum calculated for higher PPDR user density.

The top-half of the chart shows individual NB and WB spectrum calculations for normal "day-to-day" operations and for a disaster within the local area.

The total spectrum requirement is the sum of the urban and suburban calculations. For narrowband the assumption is that frequencies are not reused between the two areas, so the total is the sum of the NB urban and the NB suburban requirements. For wideband, the assumption is that some frequencies can be reused, therefore, the total is the sum of the wideband urban requirement and 1/2 of the wideband suburban requirement.

The bottom half of the chart shows the spectrum calculated for a disaster in either the urban area or the suburban area, where there is a significant increase in the number of users (up to 30% for primary users).

Normal day-to-day operations for this generic large city requires from 79 MHz to 109 MHz depending on whether it is located in a country with a medium PPDR density or a high PPDR density.

If a disaster scenario described above occurs in the suburban area, then the NB/WB spectrum requirement increases by about 6%. If disaster occurs in the urban area, then the NB/WB spectrum requirement increases by about 9%.

Disaster operations for this generic large city require from 84 MHz to 119 MHz depending on where the disaster occurs and whether it is located in a country with a medium PPDR density or a high PPDR density.

The broadband spectrum requirement needs to be added. Since broadband will cover very small radius "hot spots", the broadband frequencies can be reused throughout the urban and suburban area. **ITU-R contributions from the 2000-2003 study period have shown broadband spectrum requirements to be in the 50-75 MHz range.**

Therefore, for a generic large city, the total spectrum requirement is in the range of 134 to 194 MHz to handle the type of disaster scenario described above.

The two tables below show the breakout of PPDR users and narrowband and wideband service in a large-sized Metropolitan area.

Large Metropolitan Area calculated for 180 police officers per 100 000 population

Spectrum Requirements - Generic City Calculator				Re-Formatted	July 2002				
Metropolitan Study Area		Large Metropolitan Area		Input Data					
Population of Urban Area	8 000 000	people	1.0	Ratio Suburban/Urban Population					
Population of Surrounding Suburban Area	8 000 000	people		Ratio should be near 1.0 (Range of 0.5X to 1.5X of Urban Pop)					
Area of Urban Center	800	km ²	10.0	Ratio Suburban/Urban Area					
Area of Surrounding Suburbs	8 000	km ²		Ratio should be near 10.0 (Range of 5X to 15X of Urban Area)					
Urban Population Density	10 000	people/km ²							
Suburban Population Density	1 000	people/km ²							
"Large" or "Medium" City	LAR	If Urban Population Density > 5 000 people/km ² , then this is a large city, OR If Urban Population > 3 000 000 people, then this is a large city, otherwise this is a							
Police User Density (national average)	180.0	police per 100,000 population							
CATEGORY name and number of USER's									
User Category	Urban Day-to-Day Population	Urban Disaster Population	Suburb Day-to-Day Population	Suburban Disaster Population					
Primary - Local Police	21600	21600	18000	18000					
Secondary - Law Enforcement/Investigators	2160	4320	1800	3600					
Secondary - Police Functions	0	6480	0	5400					
Police Civilian Support	4320	4320	3600	3600					
Primary - Fire Fighters	6264	8143	5220	6786					
Fire Civilian Support	1253	1253	1044	1044					
Primary - Rescue/Emergency Medical	1879	2443	1566	2036					
Rescue/EMS Civilian Support	376	376	313	313					
Secondary - General Gov't & Civil Agencies	2160	4320	1800	3600					
Secondary - Volunteers & Other PPDR Users	1080	2160	900	1800					
Total	41092	55415	34243	46179					
Narrowband									
	Urban Day-to-Day Busy Hour Users	Urban Disaster Spectrum Required (MHz)	Suburb Day-to-Day Busy Hour Users	Suburban Disaster Spectrum Required (MHz)					
NB Voice Service	10058	21.2	11979	25.2	8382	17.6			
NB Message Service	9463	2.5	11384	3.0	7886	2.0			
NB Status Service	9463	0.1	11384	0.1	7886	0.1			
Total Narrowband Spectrum Required (MHz)		23.7		28.3		19.8			
Normal NB Day-to-Day		43.5 MHz	23.7	<	<	<	19.8		
NB Urban Disaster Scenario		48.1 MHz	<	<	28.3	<	19.8		
NB Suburban Disaster Scenario		47.3 MHz	23.7	<	<	<	<		
Larger of the two NB disaster scenarios		48.1 MHz					23.6		
Wideband									
	Urban Day-to-Day Busy Hour Users	Urban Disaster Spectrum Required (MHz)	Suburb Day-to-Day Busy Hour Users	Suburban Disaster Spectrum Required (MHz)					
WB Data Service	7549	24.1	8279	26.4	6291	20.0			
WB Video Service	3831	0.8	4256	0.9	3193	0.7			
Total Wideband Spectrum Required (MHz)		24.9		27.4		20.7			
Normal WB Day-to-Day		35.3 MHz	24.9	<	<	<	10.3		
Urban WB Disaster Scenario		37.7 MHz	<	<	27.4	<	10.3		
Suburban WB Disaster Scenario		36.3 MHz	24.9	<	<	<	<		
Larger of the two WB disaster scenarios		37.7 MHz					11.4		
Spectrum Requirement Totals									
Normal Day-to-Day	NB	43.5	+	WB	35.3	=	Sum	78.8	MHz
Suburban Disaster Scenario		47.3	+		36.3	=		83.6	MHz
Urban Disaster Scenario		48.1	+		37.7	=		85.8	MHz

Large Metropolitan Area calculated for 250 police officers per 100 000 population

Spectrum Requirements - Generic City Calculator				Re-Formatted	July 2002			
Metropolitan Study Area		Large Metropolitan Area		Input Data				
Population of Urban Area	8 000 000	people	1.0	Ratio Suburban/Urban Population				
Population of Surrounding Suburban Area	8 000 000	people		Ratio should be near 1.0 (Range of 0.5X to 1.5X of Urban Pop)				
Area of Urban Center	800	km ²	10.0	Ratio Suburban/Urban Area				
Area of Surrounding Suburbs	8 000	km ²		Ratio should be near 10.0 (Range of 5X to 15X of Urban Area)				
Urban Population Density	10 000	people/km ²						
Suburban Population Density	1 000	people/km ²						
"Large" or "Medium" City	LAR			If Urban Population Density > 5 000 people/km ² , then this is a large city, OR If Urban Population > 3 000 000 people, then this is a large city, otherwise this is a				
Police User Density (national average)	250.0			police per 100,000 population				
CATEGORY name and number of USER's								
User Category	Urban Day-to-Day	Urban Disaster	Suburb Day-to-Day	Suburban Disaster				
	Population	Population	Population	Population				
Primary - Local Police	30000	30000	25000	25000				
Secondary - Law Enforcement/Investigators	3000	6000	2500	5000				
Secondary - Police Functions	0	9000	0	7500				
Police Civilian Support	6000	6000	5000	5000				
Primary - Fire Fighters	8700	11310	7250	9425				
Fire Civilian Support	1740	1740	1450	1450				
Primary - Rescue/Emergency Medical	2610	3393	2175	2828				
Rescue/EMS Civilian Support	522	522	435	435				
Secondary - General Gov't & Civil Agencies	3000	6000	2500	5000				
Secondary - Volunteers & Other PPDR Users	1500	3000	1250	2500				
Total	57072	76965	47560	64138				
Narrowband								
	Urban Day-to-Day	Urban Disaster	Suburb Day-to-Day	Suburban Disaster				
	Busy Hour Users	Spectrum Required (MHz)	Busy Hour Users	Spectrum Required (MHz)	Busy Hour Users	Spectrum Required (MHz)		
NB Voice Service	13969	29.4	16637	35.1	11641	24.5	13864	29.2
NB Message Service	13143	3.4	15811	4.1	10953	2.8	13176	3.4
NB Status Service	13143	0.1	15811	0.2	10953	0.1	13176	0.1
Total Narrowband Spectrum Required (MHz)		33.0		39.3		27.4		32.7
Normal NB Day-to-Day	60.4 MHz	33.0	<	<	<	27.4		
NB Urban Disaster Scenario	66.8 MHz	<	<	39.3	<	27.4		
NB Suburban Disaster Scenario	65.7 MHz	33.0	<	<	<	<	<	32.7
Larger of the two NB disaster scenarios	66.8 MHz							
Wideband								
	Urban Day-to-Day	Urban Disaster	Suburb Day-to-Day	Suburban Disaster				
	Busy Hour Users	Spectrum Required (MHz)	Busy Hour Users	Spectrum Required (MHz)	Busy Hour Users	Spectrum Required (MHz)		
WB Data Service	10485	33.5	11498	36.7	8738	27.8	9582	30.5
WB Video Service	5321	1.1	5910	1.3	4434	0.9	4925	1.0
Total Wideband Spectrum Required (MHz)		34.6		38.0		28.7		31.5
Normal WB Day-to-Day	49.0 MHz	34.6	<	<	<	14.4		
Urban WB Disaster Scenario	52.4 MHz	<	<	38.0	<	14.4		
Suburban WB Disaster Scenario	50.4 MHz	34.6	<	<	<	<	<	15.8
Larger of the two WB disaster scenarios	52.4 MHz							
Spectrum Requirement Totals								
	NB		WB		Sum			
Normal Day-to-Day	60.4	+	49.0	=	109.4	MHz		
Suburban Disaster Scenario	65.7	+	50.4	=	116.1	MHz		
Urban Disaster Scenario	66.8	+	52.4	=	119.1	MHz		

PPDR population density analysis

- National average for police officers in the range 180 or 250 police/100 000 population.
- Suburban PPDR populations based upon police density of 1.25 times the national average.
- Urban PPDR populations based upon police density of 1.5 times the national average.
- Day-to-day PPDR population estimates:
 - Local police - population based on national average
 - Law Enforcement/Investigators - 10% of police density
 - Secondary police (coming from outside) - none
 - Police civilian support - 20% of police density
 - Fire fighters - 29% of police density (~3.5 police per fire)
 - Fire civilian support - 20% of fire fighter density
 - Rescue/EMS - 30% of fire fighter density (~11.7 police per EMS)
 - EMS civilian support - 20% of rescue/EMS density
 - General Government - 10% of police density
 - Other PPDR users and volunteers - 5% of police density
- Changes in PPDR populations during a disaster:
 - Local police - population remains the same
 - Law Enforcement/Investigators - population doubles
 - Secondary police (coming from outside)
 - Additional population about 30% of local police
 - Police civilian support - population remains the same
 - Fire fighters (coming from outside) - 30% increase in fire population
 - Fire civilian support - population remains the same
 - Rescue/EMS (coming from outside) - 30% increase in fire population
 - EMS civilian support - population remains the same
 - General Government - population doubles
 - Other PPDR users and volunteers - population doubles

Summary of formulas used to calculate population density

PPDR User Category	PPDR Density	Suburban Normal	changes for disaster	Suburban Disaster
	For suburban areas use 1.25 times national average police density	$D(\text{sub}) = \text{Police density} \times 1.25 \times \text{population} / 100,000$		
Primary - Local Police			remains the same	$D(\text{sub})$
Secondary - Law Enforcement/Investigators	10% of police density	$0.10 \times D(\text{sub})$	doubles	$2.0 \times (0.10 \times D(\text{sub}))$
Secondary - Police Functions	0	$0.0 \times D(\text{sub})$	30% of police density	$0.3 \times D(\text{sub})$
Police Civilian Support	20% of police density	$0.2 \times D(\text{sub})$	remains the same	$0.2 \times D(\text{sub})$
Primary - Fire Fighters	29% of police density	$0.29 \times D(\text{sub})$	29% increase	$1.3 \times 0.29 \times D(\text{sub})$
Fire Civilian Support	20% of fire density	$0.2 \times (0.29 \times D(\text{sub}))$	remains the same	$0.2 \times 0.29 \times D(\text{sub})$
Primary - Rescue/Emergency Medical	30% of fire density	$0.3 \times (0.29 \times D(\text{sub}))$	30% increase	$1.3 \times 0.29 \times 0.5 \times D(\text{sub})$
Rescue/EMS Civilian Support	20% of EMS density	$0.2 \times (0.3 \times (0.29 \times D(\text{sub})))$	remains the same	$0.2 \times 0.3 \times 0.29 \times D(\text{sub})$
Secondary - General Gov't & Civil Agencies	10% of police density	$0.10 \times D(\text{sub})$	doubles	$2.0 \times 0.10 \times D(\text{sub})$
Secondary - Volunteers & Other PPDR	5% of police density	$0.05 \times D(\text{sub})$	doubles	$2.0 \times 0.05 \times D(\text{sub})$

PPDR User Category	PPDR Density	Urban Normal	changes for disaster	Urban Disaster
	For urban areas use 1.5 times national average police density	$D(\text{urb}) = \text{Police density} \times 1.50 \times \text{population} / 100,000$		
Primary - Local Police			remains the same	$D(\text{urb})$
Secondary - Law Enforcement/Investigators	10% of police density	$0.10 \times D(\text{urb})$	doubles	$2.0 \times (0.10 \times D(\text{urb}))$
Secondary - Police Functions	0	$0.0 \times D(\text{urb})$	30% of police density	$0.3 \times D(\text{urb})$
Police Civilian Support	20% of police density	$0.2 \times D(\text{urb})$	remains the same	$0.2 \times D(\text{urb})$
Primary - Fire Fighters	29% of police density	$0.29 \times D(\text{urb})$	29% increase	$1.3 \times 0.29 \times D(\text{urb})$
Fire Civilian Support	20% of fire density	$0.2 \times (0.29 \times D(\text{urb}))$	remains the same	$0.2 \times 0.29 \times D(\text{urb})$
Primary - Rescue/Emergency Medical	30% of fire density	$0.3 \times (0.29 \times D(\text{urb}))$	30% increase	$1.3 \times 0.29 \times 0.5 \times D(\text{urb})$
Rescue/EMS Civilian Support	20% of EMS density	$0.2 \times (0.3 \times (0.29 \times D(\text{urb})))$	remains the same	$0.2 \times 0.3 \times 0.29 \times D(\text{urb})$
Secondary - General Gov't & Civil Agencies	10% of police density	$0.10 \times D(\text{urb})$	doubles	$2.0 \times 0.10 \times D(\text{urb})$
Secondary - Volunteers & Other PPDR	5% of police density	$0.05 \times D(\text{urb})$	doubles	$2.0 \times 0.05 \times D(\text{urb})$

Example parameters

Narrowband – Medium City – Suburban - Medium PPDR Density

Population = 2 500 000 people

Area = 6 000 km²

Police Density Suburban = $U(\text{sub}) = 1.25 \times 180 \times 2\,500\,000 / 100\,000 = 5\,625$ police

Cell Radius = 14.4 km

Cell Antenna Pattern = Omni

Reuse Factor = 21

GoS factor = 1.5

Width of Frequency Band = 24 MHz

Channel Bandwidth = 12.5 kHz

% of Band not used for traffic = 10%

Narrowband – Medium City - Urban - Medium PPDR Density

Population = 2 500 000 people

Area = 600 km²

Police Density Suburban = $U(\text{urb}) = 1.5 \times 180 \times 2\,500\,000 / 100\,000 = 6\,750$ police

Cell Radius = 5.0 km

Cell Antenna Pattern = Hex

Reuse Factor = 21

GoS factor = 1.5

Width of Frequency Band = 24 MHz

Channel Bandwidth = 12.5 kHz

% of Band not used for traffic = 10%

Wideband – Medium City - Suburban - Medium PPDR Density

Population = 2 500 000 people
Area = 6 000 km²
Police Density Suburban = $U(\text{sub}) = 1.25 \times 180 \times 2\,500\,000 / 100\,000 = 5\,625$ police
Cell Radius = 9.2 km
Cell Antenna Pattern = Omni
Reuse Factor = 12
GoS factor = 1.5
Width of Frequency Band = 24 MHz
Channel Bandwidth = 150 kHz
% of Band not used for traffic = 10%

Wideband – Medium City - Urban - Medium PPDR Density

Population = 2 500 000 people
Area = 600 km²
Police Density Suburban = $U(\text{urb}) = 1.5 \times 180 \times 2\,500\,000 / 100\,000 = 6\,750$ police
Cell Radius = 3.2 km
Cell Antenna Pattern = Hex
Reuse Factor = 12
GoS factor = 1.5
Width of Frequency Band = 24 MHz
Channel Bandwidth = 150 kHz
% of Band not used for traffic = 10%

Narrowband – Large City – Suburban - Medium PPDR Density

Population = 8 000 000 people
Area = 8 000 km²
Police Density Suburban = $U(\text{sub}) = 1.25 \times 180 \times 8\,000\,000 / 100\,000 = 18\,000$ Police
Cell Radius = 11.5 km
Cell Antenna Pattern = Omni
Reuse Factor = 21
GoS factor = 1.5
Width of Frequency Band = 24 MHz
Channel Bandwidth = 12.5 kHz
% of Band not used for traffic = 10%

Narrowband – Large City - Urban - Medium PPDR Density

Population = 8 000 000 people
Area = 800 km²
Police Density Suburban = $U(\text{urb}) = 1.5 \times 180 \times 8\,000\,000 / 100\,000 = 21\,600$ Police
Cell Radius = 4.0 km
Cell Antenna Pattern = Hex
Reuse Factor = 21
GoS factor = 1.5
Width of Frequency Band = 24 MHz
Channel Bandwidth = 12.5 kHz
% of Band not used for traffic = 10%

Wideband – Large City - Suburban - Medium PPDR Density

Population = 8 000 000 people
Area = 8 000 km²
Police Density Suburban = $U(\text{sub}) = 1.25 \times 180 \times 8\,000\,000 / 100\,000 = 18\,000$ Police
Cell Radius = 7.35 km
Cell Antenna Pattern = Omni
Reuse Factor = 12
GoS factor = 1.5
Width of Frequency Band = 24 MHz
Channel Bandwidth = 150 kHz
% of Band not used for traffic = 10%

Wideband – Large City - Urban - Medium PPDR Density

Population = 8 000 000 people

Area = 800 km²

Police Density Suburban = U(urb) = $1.5 \times 180 \times 2\,500\,000 / 100\,000 = 21\,600$ Police

Cell Radius = 2.56 km

Cell Antenna Pattern = Hex

Reuse Factor = 12

GoS factor = 1.5

Width of Frequency Band = 24 MHz

Channel Bandwidth = 150 kHz

% of Band not used for traffic = 10%

Annex 5

Existing and emerging solutions to support interoperability for Public Protection and Disaster Relief

1 Introduction

Interoperability is becoming increasingly important for PPDR operations. PPDR interoperability is the ability of PPDR personnel from one agency/organization to communicate by radio with personnel from another agency/organization, on demand (planned and unplanned) and in real time. There are several elements/components which affect interoperability including, spectrum, technology, network, standards, planning, and available resources. Regarding the technology element, there are a variety of solutions implemented either through pre-planning activities or by using particular technologies, which could support and facilitate interoperability.

A variety of these new technologies with future enhancements including developments in digital processing techniques, could be applied to increase the data throughput of systems supporting PPDR. These technologies could also support and may enable dissimilar radios to be interoperable across different frequency bands and with different waveforms. Current advanced solutions could also satisfy some PPDR requirements by assisting the migration to new technology solutions. This Annex provides a general description of some of the existing and emerging solutions which PPDR agencies and organizations could employ in combination with the other key elements (spectrum, standards, etc.) required to facilitate interoperability.

2 Existing solutions

Because of each administration's ability to adopt and implement different standards and policies, harmonizing frequency bands on a global/regional basis for future PPDR solutions may not satisfy full interoperability with either future or legacy equipment. The following solutions have historically been used to facilitate interoperability.

Cross-band repeaters

Although less spectrum efficient, the cross-band repeater solution may provide interoperability, especially on a temporary basis. It is a viable solution when agencies, which need to interoperate use different bands and have incompatible systems (either conventional or trunked communications systems, using analog versus digital modulation and operating in wideband versus narrowband mode). Currently, this solution is a practical approach for radio-radio interconnection because audio and Push-To-Talk (PTT) logic inputs and outputs are typically available. It requires little or no dispatcher involvement and is typically automated. Once activated, all broadcasts from one channel of one radio system are rebroadcast onto one channel of the second radio system. It also allows each user group involved to use its own subscriber equipment and allows subscriber equipment to have only basic features. The mobile radio implementation of cross-band repeaters is used, especially in mobile command vehicles, by public protection agencies to interconnect mobile users in different frequency bands. Using cross-banding repeaters is a method to solve spectrum and standards incompatibilities with a technology that exists today.

Radio reprogramming

Radio reprogramming to provide channel interoperability occurs between user groups operating in the same frequency band by allowing frequencies to be installed in all incident responders' radio equipment. Therefore, in order for this to be an effective solution, the radios should have this as a built-in capability. Radio reprogramming costs less than other interoperability solutions; it may or

may not require additional infrastructure; it does not require coordinating and licensing of additional frequencies; and it can provide interoperability on very short notice. New techniques such as over the air reprogramming allow for instantaneous reprogramming to first responders in critical situations. This can be extremely useful in providing dynamic changes in a chaotic environment.

Radio exchange

Exchange of radios is a simple means to obtain interoperability. Radio exchange provides interoperability between responders with incompatible systems; it does not require coordinating and licensing of additional frequencies; and it can provide interoperability on very short notice.

Multi-band, multi-mode radios

Although the initial investment to purchase these radios is significant, it does provide several advantages: 1) no dispatcher intervention is required; 2) users can establish more than one simultaneous interoperability talk group or channel simply by having subscriber units switch to the proper frequency or operational mode; 3) agencies need not change, reprogram, or add to the radio system infrastructure on any backbone systems; 4) outside users can join the interoperability talk group(s) or channel(s) by simply selecting the right switch positions on their subscriber units; and 5) no additional wireline leased circuits are needed. Multi-band, multi-mode radios can provide interoperability among subscriber units on the same radio system or on different systems. Equipment specifically designed and currently available that can operate on many frequency bands and in different voice and data modes. This also provides flexibility for users to operate independent systems in support of their missions with the added capability of linking different systems and bands on an as needed basis. Although this solution is not wide-spread due to the lack of software defined radios (SDR), many public protection agencies use radios that operate in different frequency bands for interoperability.

SDR technology, for example, may permit interoperability without incurring other incompatibilities. The use of SDRs for commercial use, particularly for PPDR has potential advantages for meeting multiple standards, multiple frequencies, and the reduction of mobile and station equipment complexity.

Commercial services

The use of commercial services is effective in providing interoperability for by some extent PPDR organizations on an interim basis, particularly when administrative connectivity between disparate users is necessary. This interoperability solution is also beneficial in off loading administrative or non-critical communications when the demand for the tactical system is greatest.

Interface/interconnect systems

Although a substantial investment is required to purchase interface/interconnect systems, they have proven to be effective in providing interoperability between different communications systems. These systems can simultaneously cross-band two or more different radio systems such as HF, VHF, UHF, 800 MHz, trunking, and satellite; or connect a radio network to a telephone line or a satellite. The ability to interface/interconnect different systems allow the users of different equipment in different bands the ability to utilize the type of equipment that best meets their requirements.

3 Emerging technology solutions for PPDR

For solving future bandwidth requirements, there are several emerging technologies that may be applied to increase the data throughput of PPDR systems which may also reduce the amount of spectrum needed to support PPDR applications.

Adaptive antenna systems

Adaptive antenna systems could improve the spectral efficiency of a radio channel and, by so doing, greatly increase the capacity and coverage of most radio transmission networks. This technology uses multiple antennas, digital processing techniques and complex algorithms to modify the transmit and receive signals at the base station and at the user terminal. Commercial, private and government radio systems might obtain significant capacity and performance improvements from the application of adaptive antenna systems. The use of adaptive antenna systems in PPDR systems could increase the capacity of those networks within a limited bandwidth.

Cross-banding

Cross-banding is a solution that permits a radio operating on one frequency band to interoperate with another radio in a different frequency band is a technology that the PPDR community already uses and needs to use even more. Cross-banding can yield dividends because it permits operators to continue using existing frequencies and lets the translator do the work to accommodate the various users across different bands. If Software Defined Radio (SDR) technology is incorporated into the translator first, then legacy systems with their current waveforms can interoperate today, and these systems can be adaptable for tomorrow.

One other consideration with translators is the possibility of cross-moding, which could, for example, permit a UHF AM radio to interoperate with a UHF FM radio.

Software Defined Radio

Enhanced functions for the user are possible with Software Defined Radio (SDR) technology that uses computer software to generate its operating parameters, particularly those involving waveforms and signal processing. This is currently in use by some government agencies. Some companies are also starting to benefit by using SDR technology in their products. SDR's systems have the ability to span multiple bands and multiple modes of operation and will have the capability in the future to adjust its operating parameters, or reconfigure itself, in response to changing environmental conditions. An SDR radio will be able to electronically "scan" the spectrum to determine if its current mode of operation will permit it to operate in a compatible fashion with both legacy systems and other SDRs on a particular frequency in a particular mode. SDR systems could be capable of transmitting voice, video, and data, and have the ability to incorporate cross-banding which could allow for the ability to communicate, bridge, and route communications across dissimilar systems. Such systems could be remotely controlled, and may be compatible with new products and backward compatible with legacy systems. By building upon a common open architecture, this SDR system will improve interoperability by providing the ability to share waveform software between radios, even radios in different physical domains. Further, SDR technology could facilitate public protection organizations to operate in an electronic environment, not be readily detected by scanners, and be protected from interference by a sophisticated criminal element. Additionally, this system can replace a number of radios currently operating over a wide range of frequencies and it interoperates with radios operating in disparate portions of that spectrum.

