



INTERNATIONAL TELECOMMUNICATION UNION

**ITU-T**

TELECOMMUNICATION  
STANDARDIZATION SECTOR  
OF ITU

**E.737**

(05/97)

SERIES E: OVERALL NETWORK OPERATION,  
TELEPHONE SERVICE, SERVICE OPERATION AND  
HUMAN FACTORS

Quality of service, network management and traffic  
engineering – Traffic engineering – ISDN traffic  
engineering

---

## **Dimensioning methods for B-ISDN**

ITU-T Recommendation E.737

(Previously CCITT Recommendation)

---

ITU-T E-SERIES RECOMMENDATIONS

**OVERALL NETWORK OPERATION, TELEPHONE SERVICE, SERVICE OPERATION AND HUMAN FACTORS**

***OPERATION, NUMBERING, ROUTING AND MOBILE SERVICES***

INTERNATIONAL OPERATION	E.100–E.229
OPERATIONAL PROVISIONS RELATING TO CHARGING AND ACCOUNTING IN THE INTERNATIONAL TELEPHONE SERVICE	E.230–E.299
UTILIZATION OF THE INTERNATIONAL TELEPHONE NETWORK FOR NON-TELEPHONY APPLICATIONS	E.300–E.329
ISDN PROVISIONS CONCERNING USERS	E.330–E.399

***QUALITY OF SERVICE, NETWORK MANAGEMENT AND TRAFFIC ENGINEERING***

NETWORK MANAGEMENT	E.400–E.489
International service statistics	E.400–E.409
International network management	E.410–E.419
Checking the quality of the international telephone service	E.420–E.489
TRAFFIC ENGINEERING	E.490–E.799
Measurement and recording of traffic	E.490–E.505
Forecasting of traffic	E.506–E.509
Determination of the number of circuits in manual operation	E.510–E.519
Determination of the number of circuits in automatic and semi-automatic operation	E.520–E.539
Grade of service	E.540–E.599
Definitions	E.600–E.699
<b>ISDN traffic engineering</b>	<b>E.700–E.749</b>
Mobile network traffic engineering	E.750–E.799
QUALITY OF TELECOMMUNICATION SERVICES: CONCEPTS, MODELS, OBJECTIVES AND DEPENDABILITY PLANNING	E.800–E.899
Terms and definitions related to the quality of telecommunication services	E.800–E.809
Models for telecommunication services	E.810–E.844
Objectives for quality of service and related concepts of telecommunication services	E.845–E.859
Use of quality of service objectives for planning of telecommunication networks	E.860–E.879
Field data collection and evaluation on the performance of equipment, networks and services	E.880–E.899

*For further details, please refer to ITU-T List of Recommendations.*

## **ITU-T RECOMMENDATION E.737**

### **DIMENSIONING METHODS FOR B-ISDN**

#### **Summary**

This Recommendation provides general principles and methods for dimensioning B-ISDNs from the call and connection level perspective. A network modelling technique for dimensioning and call and connection level traffic controls such as traffic routing and bandwidth reservation are described. Call demand types that are taken into account for network dimensioning considering available B-ISDN signalling capabilities are presented. Principles of network dimensioning methods are described and several example methods for computing end-to-end GOS (i.e. call/connection blocking probabilities) are provided.

#### **Source**

ITU-T Recommendation E.737 was prepared by ITU-T Study Group 2 (1997-2000) and was approved under the WTSC Resolution No. 1 procedure on the 26th of May 1997.

## FOREWORD

ITU (International Telecommunication Union) is the United Nations Specialized Agency in the field of telecommunications. The ITU Telecommunication Standardization Sector (ITU-T) is a permanent organ of the ITU. The ITU-T is responsible for studying technical, operating and tariff questions and issuing Recommendations on them with a view to standardizing telecommunications on a worldwide basis.

The World Telecommunication Standardization Conference (WTSC), which meets every four years, establishes the topics for study by the ITU-T Study Groups which, in their turn, produce Recommendations on these topics.

The approval of Recommendations by the Members of the ITU-T is covered by the procedure laid down in WTSC Resolution No. 1.

In some areas of information technology which fall within ITU-T's purview, the necessary standards are prepared on a collaborative basis with ISO and IEC.

## NOTE

In this Recommendation, the expression "Administration" is used for conciseness to indicate both a telecommunication administration and a recognized operating agency.

## INTELLECTUAL PROPERTY RIGHTS

The ITU draws attention to the possibility that the practice or implementation of this Recommendation may involve the use of a claimed Intellectual Property Right. The ITU takes no position concerning the evidence, validity or applicability of claimed Intellectual Property Rights, whether asserted by ITU members or others outside of the Recommendation development process.

As of the date of approval of this Recommendation, the ITU had/had not received notice of intellectual property, protected by patents, which may be required to implement this Recommendation. However, implementors are cautioned that this may not represent the latest information and are therefore strongly urged to consult the TSB patent database.

© ITU 1998

All rights reserved. No part of this publication may be reproduced or utilized in any form or by any means, electronic or mechanical, including photocopying and microfilm, without permission in writing from the ITU.

## CONTENTS

		<i>Page</i>
1	Scope of the Recommendation.....	1
2	References.....	1
3	Terms and definitions.....	2
4	Abbreviations.....	3
5	Introduction.....	3
6	Network modelling for dimensioning.....	6
	6.1 Network model.....	6
	6.2 Network dimensioning objectives and GOS objectives.....	7
7	Call and connection level traffic control.....	8
	7.1 Routing of an ATM connection.....	8
	7.2 Service protection schemes.....	9
	7.3 Call priority.....	9
	7.4 Bandwidth negotiation at connection set-up time.....	10
8	Modelling of offered traffic.....	10
	8.1 Overview of call/connection controls supported in B-ISDN.....	10
	8.2 Call demand types.....	11
9	Dimensioning a single VPC/bandwidth module group.....	11
	9.1 Model for dimensioning.....	12
	9.2 Principles of the dimensioning method.....	13
	9.3 Computing connection blocking probabilities of a VPC/bandwidth module group.....	14
10	Dimensioning a network.....	15
	10.1 Principles of network dimensioning methods.....	15
	10.2 Principles of end-to-end blocking calculation methods.....	16
	10.3 Computing blocking probabilities for a network with type A calls.....	18
	10.4 Computing blocking probabilities for a network with type B calls.....	19
	10.5 Computing blocking probabilities for a network with other call types.....	19
11	History.....	19
Annex A – Example calculation methods for individual blocking probabilities at a VPC/bandwidth module group		19
	A.1 Summary of methods.....	19
	A.2 Notation.....	20
	A.3 Kaufman-Roberts method.....	21
	A.4 Hayward-type method.....	21
Annex B – An example method for computing blocking probabilities for a network with type A calls.....		22
	B.1 Example with the load sharing routing scheme.....	22
	B.2 Example with an alternative routing scheme.....	25
Annex C – An example method for computing blocking probabilities for a network with type B calls.....		26
	C.1 Example with load sharing routing scheme.....	26
Appendix I – Bibliography.....		28



## **DIMENSIONING METHODS FOR B-ISDN**

*(Geneva, 1997)*

### **1 Scope of this Recommendation**

This Recommendation is intended to provide dimensioning guidelines for B-ISDN enabling the network operator to meet call and connection level GOS objectives from the user-plane perspective. In this Recommendation, B-ISDN bearer services supported by B-ISDN signalling capability sets 1 and 2.1 are taken into account. Although on-demand virtual path connections are not supported in those signalling capability sets, they are also taken into account in the modelling of user traffic demand. This issue only concerns the ATM connections supported by deterministic bit rate and statistical bit rate ATM transfer capabilities.

Dimensioning guidelines for the control-plane in the B-ISDN are outside of the scope of this Recommendation.

### **2 References**

The following ITU-T Recommendations and other references contain provisions which, through reference in this text, constitute provisions of this Recommendation. At the time of publication, the editions indicated were valid. All Recommendations and other references are subject to revision; all users of this Recommendation are therefore encouraged to investigate the possibility of applying the most recent edition of the Recommendations and other references listed below. A list of the currently valid ITU-T Recommendations is regularly published.

- CCITT Recommendation E.170 (1992), *Traffic routing*.
- ITU-T Recommendation E.177 (1996), *B-ISDN routing*.
- CCITT Recommendation E.525 (1992), *Designing networks to control grade of service*.
- ITU-T Recommendation E.526 (1993), *Dimensioning a circuit group with multi-slot bearer services and no overflow inputs*.
- ITU-T Recommendation E.716 (1996), *User demand modelling in Broadband-ISDN*.
- CCITT Recommendation E.731 (1992), *Methods for dimensioning resources operating in circuit-switched mode*.
- ITU-T Recommendation E.735 (1997), *Framework for traffic control and dimensioning in B-ISDN*.
- ITU-T Recommendation E.736 (1997), *Methods for cell level traffic control in B-ISDN*.
- CCITT Recommendation I.121 (1991), *Broadband aspects of ISDN*.
- ITU-T Recommendation I.150 (1995), *B-ISDN asynchronous transfer mode functional characteristics*.
- ITU-T Recommendation Q.2721.1 (1996), *B-ISDN user part – Overview of the B-ISDN network node interface signalling capability set 2, step 1*.
- ITU-T Recommendation Q.2722.1 (1996), *B-ISDN user part – Network node interface specification for point-to-multipoint call/connection control*.
- ITU-T Recommendation Q.2725.1 (1996), *B-ISDN user part – Support of negotiation during connection setup*.
- ITU-T Recommendation Q.2725.2 (1996), *B-ISDN user part – Modification procedures*.

- ITU-T Recommendation Q.2726.2 (1996), *B-ISDN user part – Call priority*.
- ITU-T Recommendation Q.2761 (1995), *Functional description of the B-ISDN User Part (B-ISUP) of Signalling System No. 7*.
- ITU-T Recommendation Q.2762 (1995), *General functions of messages and signals of the B-ISDN User Part (B-ISUP) of Signalling System No. 7*.
- ITU-T Recommendation Q.2763 (1995), *Signalling System No. 7 B-ISDN User Part (B-ISUP) – Formats and codes*.
- ITU-T Recommendation Q.2764 (1995), *Signalling System No. 7 B-ISDN User Part (B-ISUP) – Basic call procedures*.
- ITU-T Recommendation Q.2931 (1995), *Digital subscriber Signalling System No. 2 – User-Network Interface (UNI) layer 3 specification for basic call/connection control*.
- ITU-T Recommendation Q.2959 (1996), *Digital subscriber Signalling System No. 2 – Call priority*.
- ITU-T Recommendation Q.2961 (1995), *Broadband Integrated Services Digital Network (B-ISDN) – Digital subscriber Signalling System No. 2 (DSS 2) – Additional traffic parameters*.
- ITU-T Recommendation Q.2962 (1996), *Digital subscriber Signalling System No. 2 – Connection characteristics negotiation during call/connection establishment phase*.
- ITU-T Recommendation Q.2963.1 (1996), *Digital subscriber Signalling System No. 2 – Connection modification: Peak rate modification by the connection owner*.
- ITU-T Recommendation Q.2971 (1995), *Digital subscriber Signalling System No. 2 – User-network interface layer 3 specification for point-to-multipoint call/connection control*.

### 3 Terms and definitions

This Recommendation defines the following terms.

- 3.1 ATM connection:** A VCC or VPC.
- 3.2 forward direction:** Direction of communication from the calling user to the called user.
- 3.3 backward direction:** Direction of communication from the called user to the calling user.
- 3.4 ATM link:** Transmission path together with its associated buffer in the upstream node.
- 3.5 ATM link set:** Set of all the ATM links with the same direction of transmission interconnecting two ATM nodes without any intermediate ATM nodes.
- 3.6 VPC set:** Set of all the VPCs with the same direction of transmission interconnecting two VC nodes without any intermediate VC nodes.
- 3.7 bandwidth module:** An amount of bandwidth of an ATM link that is not allocated to network-to-network VPCs but can be allocated to user-to-user VPCs/VCCs (see 6.1).
- 3.8 bandwidth module set:** Set of all the bandwidth modules in an ATM link set.
- 3.9 VPC group:** VPCs in a given VPC set that have the same permanent characteristics and performance characteristics, e.g. propagation delay, cell level performance.
- 3.10 bandwidth module group:** Bandwidth modules in a given bandwidth module set that have the same permanent characteristics and performance characteristics, e.g. propagation delay, cell level performance.
- 3.11 route:** A concatenation of VPC groups/bandwidth module groups from the originating node to the destination node of an ATM connection.
- 3.12 equivalent cell rate:** A cell rate attributed to a connection such that cell level GOS objectives are satisfied on an ATM link or network VPC as long as the sum of equivalent cell rates is not greater than the rate of the ATM link or VPC.

Note that all the objects (i.e. connection, link, bandwidth module, respective sets and groups, and route) defined above are unidirectional.



## 4 Abbreviations

This Recommendation uses the following abbreviations:

ATM	Asynchronous Transfer Mode
B-ISDN	Broadband Integrated Services Digital Network
CAC	Connection Admission Control
CLP	Cell Loss Priority
CSn	Capability Set n
DBR	Deterministic Bit Rate
ECR	Equivalent Cell Rate
GOS	Grade of Service
INI	Inter-Network Interface
N-ISDN	Narrow-band Integrated Services Digital Network
PCR	Peak Cell Rate
PSTN	Public Switched Telephone Network
QOS	Quality of Service
STD	Source Traffic Descriptor
TP	Transmission Path
UNI	User Network Interface
VC	Virtual Channel
VCC	Virtual Channel Connection
VP	Virtual Path
VPC	Virtual Path Connection
VPI	Virtual Path Identifier

## 5 Introduction

B-ISDN will support switched, semi-permanent and permanent, point-to-point and point-to-multipoint ATM connections and provides on-demand, reserved and permanent bearer services, as stated in Recommendation I.121. Such a B-ISDN bearer service is provided by using user-to-user ATM connections which are established in the network. This Recommendation focuses on on-demand B-ISDN bearer services provided for users.

Recommendation E.735 provides the framework for traffic control and dimensioning in B-ISDN to give a general guideline for network design. Recommendation E.735 describes the general structure of the B-ISDN, different types of networks and the relation between cell level traffic control treated in Recommendation E.736 and dimensioning. This Recommendation is based on the framework in Recommendation E.735.

According to Recommendation E.735, a Transmission Path (TP) interconnecting two physically adjacent ATM nodes together with its associated buffer is called an **ATM link**, and the set of all the ATM links between the two nodes is called an **ATM link set**. A link is routed through a concatenation of transmission facilities. The links in a set may have different characteristics (e.g. propagation delay). Network-to-network VPCs may be established between two adjacent VC nodes or the VC part of two adjacent VP-VC nodes. The set of all the VPCs between the two nodes is called a **VPC set** in the E.700-Series Recommendations on traffic engineering for B-ISDN. A network-to-network VPC is routed through a concatenation of ATM links interconnecting its originating and destination nodes, so that the VPCs in a VPC set may not be homogeneous with respect to permanent characteristics such as the number of VP links on a VPC and the

propagation delay. Within a VPC set, VPCs that have the same permanent characteristics and cell level performance characteristics will be termed a **VPC group**<sup>1</sup>. Every VPC in a VPC set belongs to one of the VPC groups in the set. A VPC group may be composed of a single VPC. This Recommendation assumes that a given VPC provides the same cell level performance to all the VCCs it contains. Therefore, a common performance characteristic is that all VCCs are provided with the same cell level performance, e.g. cell loss, cell delay, cell delay variation. The VPCs in a VPC group are of the same type (i.e. shaped DBR VPC, uncontrolled constant rate VPC or variable rate VPC). In this Recommendation, an amount of bandwidth of an ATM link that is not allocated to network-to-network VPCs but can be allocated to user-to-user VPCs/VCCs is called a **bandwidth module**, and the set of all the bandwidth modules terminated between the same two adjacent ATM nodes is called a **bandwidth module set**. As for grouping VPCs in a VPC set, within a bandwidth module set, bandwidth modules that have the same permanent and cell level performance characteristics will be termed a **bandwidth module group**. The same principle for grouping VPCs is applied to grouping bandwidth modules in a bandwidth module set. Figure 5-1 shows ATM links, VPCs and bandwidth modules in a network.

It is assumed in this Recommendation that the impact on network dimensioning of cell level control mechanisms and buffer capacity limitations are taken into account through the notion of Equivalent Cell Rate (ECR), as discussed in Recommendations E.735 and E.736: each connection request is uniquely characterized for network dimensioning purposes by its ECR value. As this Recommendation concerns dimensioning of bandwidth, note that if any factors that determined the ECR are changed (e.g. buffer sizes), the revised ECRs can have an impact on the needed dimensioning of bandwidth. The impact of Cell Loss Priority (CLP) is for further study.

In general, the major design variables to be determined in dimensioning the B-ISDN from the call and connection level perspective are as follows:

- at the physical level:
  - 1) the size of each ATM link set, that is, the number of TPs with various available capacities (e.g. 45 Mbits/s, 155 Mbits/s, 620 Mbits/s);
  - 2) an assignment of network-to-network VPCs and bandwidth modules to TPs.
- at the logical level:
  - 1) the size of each network-to-network VPC and bandwidth module and each VPC/bandwidth module group;
  - 2) parameters defining call and connection level traffic control such as call and connection routing and service protection methods.

Defining network topology both at the logical and physical levels is outside of the scope of this Recommendation. Transmission network design (e.g. sizing of transmission facilities and assignment of TPs to transmission facilities) is also outside of the scope of this Recommendation.

The objective of this Recommendation is to provide possible methods which are useful for dimensioning the network for a given set of traffic demand assumptions and GOS objectives, particularly, call/connection blocking probability objectives. In order to dimension a network to meet GOS objectives, it is important to be able to evaluate the GOS performance of a network of given dimensions to judge whether the performance is satisfactory. This Recommendation mainly presents network modelling techniques and GOS performance evaluation methods.

Considering the alignment with the current progress in B-ISDN related standardization, the following B-ISDN capabilities having a significant impact on dimensioning the network are focused on in this Recommendation:

- a semi-permanent VPC network to configure a VCC-based bearer service network;

---

<sup>1</sup> The definition of VPC group in this Recommendation is the same as that in Recommendation E.177 except that the VPC group in this Recommendation is unidirectional, that is, defined for each forward and backward direction of transmission. In this Recommendation, a particular case is considered where the VPC groups are a disjoint partition of the VPC set.

- on-demand bearer services provided by user-to-user ATM connections;
- symmetrical or asymmetrical calls;
- unidirectional point-to-multipoint calls/connections;
- call priority;
- negotiation at call/connection set-up time.

The scope and contents of this Recommendation will be extended in order to satisfy operational needs which arise according to the evolution of network capabilities.

VC or VP-VC node A

VC or VP-VC node B

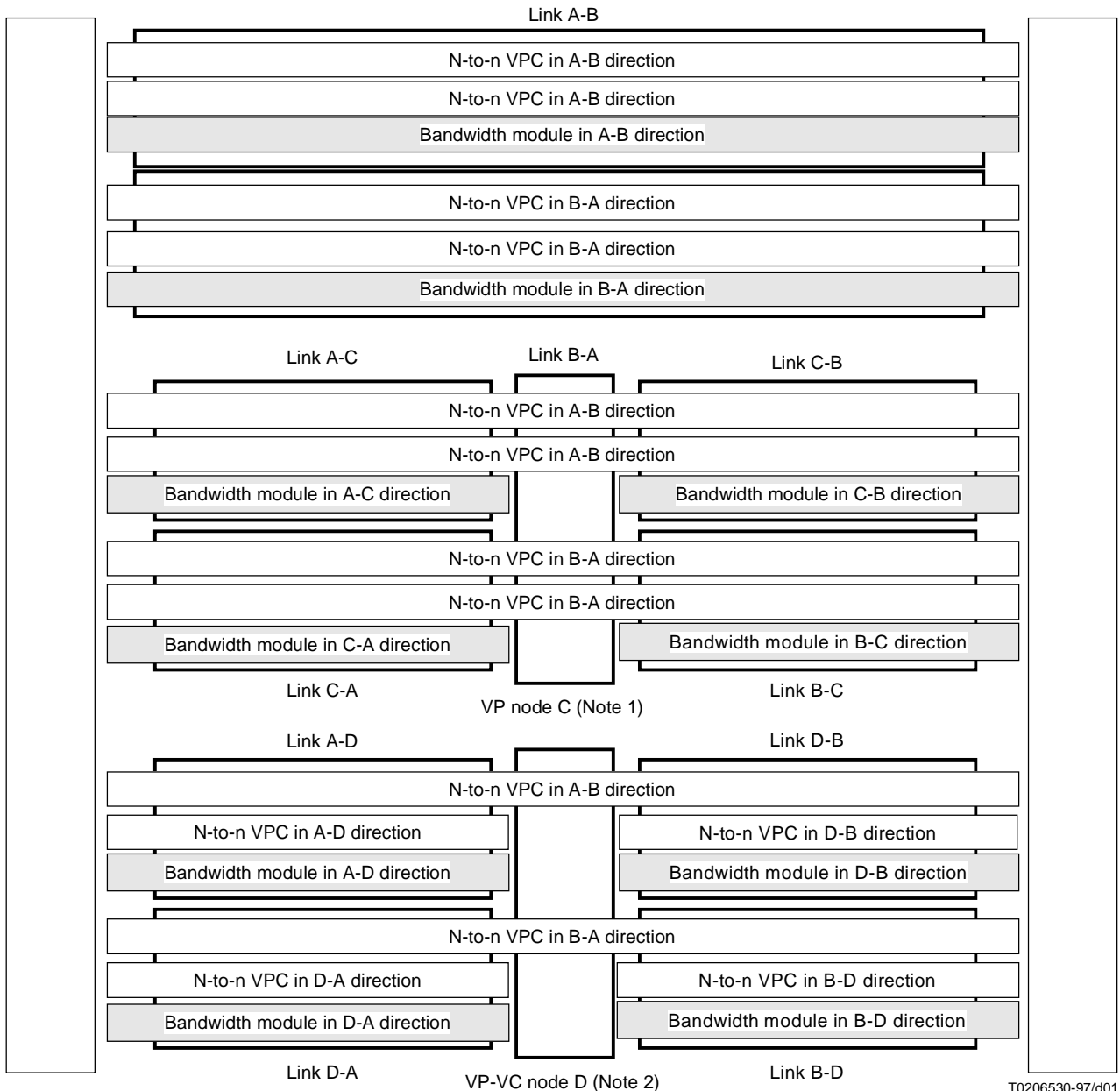

T0206530-97/d01

NOTE 1 – On-demand user-to-user VPCs can be established through the bandwidth module terminated at a VP node.

NOTE 2 – On-demand user-to-user VPCs and VCCs can be established through the bandwidth module terminated at a VP-VC node.

**Figure 5-1/E.737 – An example of VPC/bandwidth module configurations**

## 6 Network modelling for dimensioning

### 6.1 Network model

For the purpose of call and connection level traffic engineering, a network at the logical level can be modelled as a system composed of a number of building blocks, each building block being a network-to-network VPC or a bandwidth module. Figure 5-1 shows an example network model which supports on-demand user-to-user VCCs and VPCs simultaneously.

Three types of VPCs are identified in Recommendation E.735:

- 1) shaped DBR VPCs;
- 2) uncontrolled constant rate VPCs; and
- 3) variable rate VPCs.

Table 6-1 summarizes the parameter which represents bandwidth of each type of VPC. In case of a variable rate VPC, the bandwidth can be different in each of the links on which it is carried, since a different ECR value can be assigned to the VPC in each link. In Recommendation E.736, example CAC procedures are provided for an ATM link with each of the three types of VPC and each of two multiplexing schemes: the peak rate allocation scheme and the rate envelope multiplexing scheme.

**Table 6-1/E.737 – Bandwidth of VPC**

Type of VPC	Bandwidth
Shaped DBR VPC	PCR
Uncontrolled constant rate VPC	Rate
Variable rate VPC	ECR

In this Recommendation, for the purpose of simplifying the network model for dimensioning, it is assumed that the CAC of a link is based on the ECR model; this means that the CAC of the link assigns an ECR to each connection to be carried<sup>2</sup>, and can accept new connections while the sum of the ECRs of the established connections does not exceed the bandwidth of the link. Several network-to-network VPCs can be pre-established on a link. An on-demand user-to-user VCC is assigned to the appropriate network-to-network VPC or is directly established on the link based, for example, on the requested destination or the connection type. On-demand user-to-user VPCs are directly established on the link. When network-to-network VPCs are pre-established on a link, it is assumed that the ECR model also applies both to the CAC of the link and to the CAC of each VPC. For this purpose, an amount of bandwidth is assigned to each pre-established VPC and the remaining amount of bandwidth of the link is assigned to the bandwidth module which, by definition, is the amount of link bandwidth that is used to carry both on-demand user-to-user VCCs carried directly on the link and on-demand user-to-user VPCs. Thus, the capacity of the bandwidth module in a link is given by:

$$\text{Bandwidth of a bandwidth module} = \text{link transmission rate} - \Sigma(\text{ECR of all network-to-network VPCs in the link}). \quad (6-1)$$

The CACs of the VPCs and of the link assume that the sum of the ECR<sup>3</sup> of the connections carried on each VPC/bandwidth module does not exceed the bandwidth assigned to it.

<sup>2</sup> The ECR of each connection depends on the traffic characteristics of the connection and on the parameters and attributes determining the capacity of the link (bandwidth, buffer size and priority control mechanisms and parameters) and its expected traffic mix.

<sup>3</sup> Note that the ECR of a connection when the link has been partitioned into VPCs/bandwidth modules may be different from its ECR when the partitioning is not performed.

The bandwidth of a VPC/bandwidth module group is given by the sum of the bandwidths of the VPCs/bandwidth modules in the group, where the VPCs in the group are all of the same type.

It should be noted that a network model to be studied will depend on the required precision of dimensioning. In the initial stage of network dimensioning as in long-term network planning, an approximate network model may be developed, for instance, to find suitable network configurations and capture overall capacity requirements. A simple example is to represent the whole unidirectional capacity between two adjacent nodes by a single ATM link, VPC or bandwidth module.

The B-ISDN will support a wide variety of calls/connections, and the call/connection types supported in the network will evolve according to progress in the call handling capabilities of the network. The B-ISDN at initial stage with Signalling CS-1 can support an asymmetric call with point-to-point configuration (see Recommendations Q.2761, Q.2762, Q.2763, Q.2764 and Q.2931). The network at later stages may support more complex call types such as multiconnection calls and multipoint calls. For traffic engineering purposes, a model must be constructed to represent the traffic offered to the target network by specifying assumed call and connection types. Therefore, appropriate call demand types for traffic engineering purposes are needed to make traffic models tractable and, at the same time, to capture the essential factors that have a significant impact on network dimensioning. Clause 8 treats call demand types for B-ISDN dimensioning.

## **6.2 Network dimensioning objectives and GOS objectives**

The major objective of call and connection level network dimensioning is to determine the capacity parameters of links, VPCs and bandwidth modules in the network together with call and connection level traffic control parameters to achieve defined GOS objectives in an economical way. In this Recommendation, end-to-end call and connection blocking probabilities are provisionally considered as the GOS parameters which must be taken into account in the network dimensioning process. End-to-end call/connection blocking probability is defined here as the probability that an arriving call/connection is not successfully established due to lack of sufficient resources for the call/connection in the user-plane of the network. Target values of the GOS parameters will be dealt with in Recommendations of the E.720-Series.

Dimensioning should be performed to meet GOS objectives in a reference period. A difficulty arises in B-ISDN for determining the appropriate length of the reference period given the large variety of holding times of the calls. For example, a telephone call may have a duration of a few minutes while videoconferences may have a duration of several hours. A reference period of one hour (the busy hour) could be appropriate for telephone calls. Even though the long-term distribution of the number of long duration calls could be considered Poissonian during the busy hour (e.g. taking into account the busy hours during one year), this number is nearly fixed in each particular busy hour. Thus, the grade of service for short duration calls is not qualitatively the same as with resources only dedicated to short duration calls since the expected blocking probability varies strongly from busy hour to busy hour (depending on the amount of resources occupied by the long duration calls in each busy hour) [ROB]. This variation of the expected blocking probabilities from busy hour to busy hour for the short duration calls is greater if the bandwidth required by a long duration call is significantly larger than the bandwidth required by a short duration call. A service protection method which guarantees a minimum amount of resources for the calls of services with expected short duration, thus assuring a certain grade of service for these calls in the worst busy hour, is recommended. Further study is required on the implications of the large variety of holding times.

The end-to-end blocking objectives are partitioned into blocking objectives for each part of the network. Network dimensioning may, therefore, be simplified by decomposing the whole network model into smaller network models. Partitioning the GOS objectives will be dealt with in the E.720-Series Recommendations.

Since resource allocation for an ATM connection in a B-ISDN is performed both at the times of connection set-up and when a modification to connection parameters is made during the lifetime of the connection (see Recommendations Q.2725.1, Q.2725.2, Q.2962 and Q.2963.1), blocking in both cases is involved in the call and connection performance parameters. In this Recommendation, however, only blocking of connection set-up requests is treated, and thus it is called connection blocking. Blocking of connection modification requests is for further study.

## 7 Call and connection level traffic control

Call and connection level traffic controls most relevant to network dimensioning are:

- 1) call/connection routing schemes;
- 2) service protection methods;
- 3) call priority;
- 4) bandwidth negotiation.

These traffic controls have a significant impact on dimensioning the network.

### 7.1 Routing of an ATM connection

In order to establish an ATM connection requested by a user, a route between the pair of originating and destination nodes and then a VPC/bandwidth module in each VPC/bandwidth module group of the route must be selected, a route being defined as a concatenation of VPC/bandwidth module groups from the originating node to the destination node. Routing is a call and connection level traffic control and, in the network model for traffic engineering, routing schemes constitute a rule to determine to which VPCs/bandwidth modules a given ATM connection is assigned.

#### 7.1.1 Overview of the routing process

As stated in Recommendation E.177, routing of an on-demand ATM connection in the B-ISDN consists of two processes: a route selection process and a VPC/bandwidth module selection process. These two processes may be performed simultaneously. As a result of the two processes, a concatenation of VPCs/bandwidth modules from the originating node to the destination node is determined for each of the requested connections.

##### 1) *Route selection*

Route selection consists in determining the route over which a connection is to be established. Routes that can be assigned to a class of connections may depend on various factors such as the cell level QOS requirements of the connections, the service and QOS classes provided by the network, network operation policy, etc. For instance, a particular route may not be used for particular classes of connections due to the unsatisfactory propagation delay of the route for those connections. This arrangement may lead to a restriction on the range of assignable routes in connection routing. Since the restriction and route selection rules have an impact on the availability of network resources for each class of connections and thus on the call and connection level performance of the network, they must be considered in dimensioning the network. For network dimensioning purposes, however, a simplified model of the route selection schemes may be used in the network model.

A fixed routing scheme is such that a particular class of ATM connections is associated with a particular VPC/bandwidth module group and a connection blocked at that VPC/bandwidth module group is assumed to be lost and cleared. Other possible schemes applied to selecting routes in the network are load sharing, fixed alternative routing, dynamic routing, etc. Recommendation E.170 presents the principles of traffic routing.

##### 2) *VPC/bandwidth module selection*

If more than one VPC/bandwidth module is available for a new connection at a VPC group/bandwidth module group along the selected route, it is necessary to determine to which VPC/bandwidth module the connection should be assigned. Selections of VPC/bandwidth modules for each connection in a call may be mutually dependent. For instance, as specified in Recommendation E.150, the same VPI is assigned for both directions of transmission of a given communication at a B-ISDN interface. The dependency among VPC/bandwidth module selections for connections in a call also leads to a restriction in routing ATM connections in the network. Since the restrictions and VPC/bandwidth module selection rules have an impact on the availability of the resources of VPC groups/bandwidth module groups for each class of connections and thus on call and connection level performance of the VPC groups/bandwidth module groups, they must be considered in dimensioning the network. For network dimensioning purposes, however, a simplified model of respective VPC/bandwidth module selection schemes may be used in the network model.

## **7.2 Service protection schemes**

In order to achieve call and connection level GOS performance objectives in an economical way, some service protection schemes such as bandwidth reservation may be applied to the VPC/bandwidth module groups in the network.

Recommendations E.525 and E.731 present available service protection schemes in the framework of the multi-slot connection model. The same principle of the schemes may be applied for dimensioning a B-ISDN.

### **7.2.1 Bandwidth reservation**

The principle of bandwidth reservation is to restrict the access of a class of ATM connections depending on the bandwidth allocation state of the VPC/bandwidth module group at the connection arrival epoch. Higher utilization of a VPC/bandwidth module group may be achieved by the access control using detailed state information [OD1]. To simplify the implementation, however, access control using partial information on the states of the VPC/bandwidth module group may be applied. For instance, an ATM connection may be accepted or rejected simply based on the remaining idle bandwidth at the VPC/bandwidth module group at the time of connection arrival.

For example, given a traffic mix offered to a VPC with a certain amount of bandwidth, if no access control is used, blocking probabilities of VCCs requiring a larger bandwidth are usually higher than those of VCCs with smaller bandwidth requirements. If some of the blocking probabilities exceed their given call and connection level performance objectives, the capacity of the VPC may be simply increased to resolve the unsatisfactory level of performance. The use of bandwidth reservation, however, may resolve the problem with little or no increase in the bandwidth of the VPC. Typically, the bandwidth reservation parameters are set to reject requests of connections with lower bandwidth requirements, aiming at protecting the connection requests with higher bandwidth requirements.

For a given traffic mix and a given set of connection blocking objectives, the VPC/bandwidth module group with a given bandwidth may have three different regions of traffic load. The first is the low load region in which all the blocking objectives are satisfied without the use of bandwidth reservation. The second is the high load region in which all the objectives are satisfied with the use of bandwidth reservation. The third is the overload region in which not all the objectives are satisfied by any bandwidth reservation. Therefore, the use of bandwidth reservation may be meaningful for the high load region in the strict sense of achieving the connection level performance objectives.

For dimensioning purposes, it will be assumed that the bandwidth reservation policy will be made on a VPC/bandwidth module group basis, with independence between the policies applied to different groups. Various ways of implementing bandwidth reservation in a VPC/bandwidth module group are possible. A simplified implementation is to apply the reservation separately to each of the VPCs or bandwidth modules of the group so as to control the access of VCCs on a VPC/bandwidth module basis.

Note also that different reservation parameters may be applied to the forward and backward directions of a given call.

### **7.2.2 Other schemes**

There may be service protection schemes besides bandwidth reservation. This point needs further study.

## **7.3 Call priority**

B-ISDN Signalling CS-2.1 will support user specification of call priority (see Recommendations Q.2721.1, Q.2726.2 and Q.2959). The network may allocate resources to calls according to the priority levels and control mechanisms implemented in the network and the call priorities specified by users on a call-by-call basis.

Different call blocking objectives may be applied for the different priorities provided. Bandwidth reservation may be used for this purpose. Further implications of call priority on network dimensioning are not considered in this Recommendation.

## **7.4 Bandwidth negotiation at connection set-up time**

The principle of the bandwidth negotiation at connection set-up time is to change the resource requirement of an ATM connection from the initial requirement depending on the network states at that time. This control mechanism is supported by B-ISDN Signalling CS-2.1 (see Recommendations Q.2721.1, Q.2725.1 and Q.2962).

There may be various implementation options for bandwidth negotiation. User demand characteristics in the case where the negotiation mechanism is available in the network may also vary widely. B-ISDN Signalling CS-2.1 will support user specification of an alternative ATM cell rate and minimum ATM cell rate (see Recommendation Q.2961). For traffic engineering purposes, simple models of negotiation mechanisms may be derived and used in network models. An example of a negotiation model is that, when an ATM connection is requested with a user specification of both initially intended peak cell rate and minimum acceptable peak cell rate and the initial rate is rejected by the network, the network may allocate the whole idle capacity to the connection as a result of the negotiation, assuming the allocated amount of bandwidth is then not less than the specified minimum peak cell rate (see Recommendation E.731).

Recommendation E.731 presents a multi-slot model of a circuit group in which a call negotiates its number of circuits at call set-up, and provides a method for computing the blocking probability of the call. The same technique may be applied to a model of B-ISDN when the same assumption is valid.

Details of bandwidth negotiation require further study.

## **8 Modelling of offered traffic**

In general, a call supported in the B-ISDN may consist of multiple unidirectional ATM connections. The connections may be of point-to-point or point-to-multipoint configuration. A subset of the connections requested in the call may be established on the same VPC/bandwidth module if accepted by the CAC. The number of connections in each direction of communication and connection configurations in the call are specified as one of the call attributes. Recommendation E.716 describes user demand modelling in B-ISDNs enabling the network operator to characterize the traffic offered to the B-ISDN bearer service network.

It is apparent that dimensioning by distinguishing numerous call types based on detailed traffic characteristics is difficult in reality. Therefore, call demand modelling for dimensioning purposes is necessary to facilitate a dimensioning procedure. To do so, it is important to capture the essential aspects of representative types of call supported by B-ISDN from the traffic engineering viewpoint and to derive effective call demand types.

### **8.1 Overview of call/connection controls supported in B-ISDN**

#### **8.1.1 Representative types of call/connection**

The Q-Series Recommendations relating to B-ISDN signalling specify the capabilities of the B-ISDN UNI and INI. Types of calls/connections supported by the network are determined by the B-ISDN signalling capability sets that the ATM nodes in the network support.

##### **8.1.1.1 Symmetric/asymmetric point-to-point call supported by B-ISDN Signalling CS-1**

A symmetric/asymmetric point-to-point call supported by B-ISDN Signalling CS-1 (call/connection control procedures are described in Recommendations Q.2931 and Q.2764) is able to request a pair of VCCs with different peak cell rates: one in the forward direction and another in the backward direction. The call is accepted if both VCCs are accepted. Otherwise, it is rejected.

##### **8.1.1.2 Unidirectional point-to-multipoint call supported by B-ISDN Signalling CS-2.1**

A unidirectional point-to-multipoint call/connection supported in B-ISDN Signalling CS-2.1 (the call/control procedure is described in Recommendations Q.2971 and Q.2722.1) is setup by first requesting the establishment of a connection between the root and one leaf with the indication of point-to-multipoint in the broadband bearer capability information element. After this connection set-up has been accepted by the network, additional leaves can be added from branching nodes by add-party requests from the root. A leaf may be added to or dropped from the call at any time while the call is in the active state. Note that the call is accepted if the network accepts the first connection, and it is released by dropping all leaves.



### 8.1.1.3 Other types of call

Further study is required.

### 8.1.2 Connection modification

B-ISDN Signalling CS-2.1 is capable of supporting user request for modifying the peak cell rate of an active connection (see Recommendation Q.2963.1).

In this Recommendation, the traffic modelling of connection modification is not treated. This point requires further study.

## 8.2 Call demand types

The call traffic variables define the ATM connection arrival process in the call and the holding times of the connections. Together with the call attributes, the call demands are classified into various types. This classification is only for modelling purposes.

### 1) *Type A (a point-to-point call with simultaneous multiple connections)*

A call of this type requests one or more point-to-point ATM connections between the same originating and destination nodes simultaneously at the call arrival. The call is accepted if all the connections are accepted by the network. The call may be blocked and cleared if any of the requested connections are rejected at the call arrival time. Once a call has been established, no additional connections are subsequently established, and all the connections of the call remain established until the call is released. At the end of the lifetime of the call, all the connections in the call are released simultaneously. This call demand type includes symmetric/asymmetric point-to-point calls supported by B-ISDN Signalling CS-1. The bandwidth negotiation of an ATM connection between user and network may be supported in some networks. The bandwidth negotiation in this context is performed at the time of call arrival.

### 2) *Type B (a point-to-multipoint call)*

A call of this type requests the setting-up of the first connection from the root node to one leaf node and, immediately after the acceptance of the first connection by the network, may request additional tree connections from branching nodes to the remaining leaf nodes to form a target tree connection in the network. The call is blocked and cleared if the first connection is rejected. Bandwidth negotiation may be performed for only the first connection. Some of the leaf additions may be accepted and others may be rejected if sufficient resources are not available for establishing all the additional tree connections requested. As a result, a tree connection from the root to a subset of originally intended leaves may be successfully established. It is assumed that no leaves are added to or dropped from the resultant tree connection before the end of the lifetime of the call. The entire tree connection is released at the end of the lifetime of the call. It is assumed that VC/VP links of the tree connection including the first connection do not share any VPC/bandwidth module group with each other, that is, at most one VC/VP link of the tree connection is requested at a VPC/bandwidth module group in the network.

### 3) *Other types*

Definition of other call demand types requires further study.

## 9 Dimensioning a single VPC/bandwidth module group

In this clause, dimensioning methods for a single VPC/bandwidth module group are presented. Consider a single VPC/bandwidth module group to which on-demand ATM connections are offered. A VPC/bandwidth module group is represented by a total bandwidth. Other capacity parameters of the VPCs/bandwidth modules of the group are taken into account by the ECR values.

In case of a VPC group formed by variable rate VPCs, the needed bandwidth of the group may be different in each of the ATM link sets on which it is established (since the ECRs of the VCCs may be different in each of the ATM link sets). In this case, the method described in this clause should be independently applied for dimensioning the bandwidth needed in each of the ATM link sets on which the VPC group is established.

## 9.1 Model for dimensioning

It is assumed that ATM connection requests arrive at the VPC/bandwidth module group. Each connection has its own traffic parameters and QOS requirement which represent the resource requirement of the connection. The traffic parameters may be STD parameters and/or cell traffic variables. CAC is applied to each VPC/bandwidth module in the group and a decision of acceptance or rejection is taken for each newly arriving connection. As stated in Recommendation E.735, the CAC implicitly assigns resources to each connection before checking if sufficient resources are available for a new connection. Recommendation E.735 provides a general concept of resource allocation by the CAC in a formal manner and introduces the notion of ECR.

### 9.1.1 Use of ECR

The notion of ECR is a way of representing the estimated amount of bandwidth to be allocated to a connection. The ECR of each arriving connection is derived based on available information about the capacity of the VPC/bandwidth module, the declared cell traffic characteristics and QOS requirements of the new connection request, and the declared or measured cell traffic characteristics and QOS requirements of on-going connections. Recommendation E.736 provides possible formulae for calculating ECR. Note that ECR depends on the capacity of the VPC (or link in case of a variable rate VPC and bandwidth module) and not on the capacity of the VPC/bandwidth module group. If available capacity is found for establishing a connection with the derived value of ECR, then the connection is accepted at the VPC/bandwidth module and, otherwise, it is rejected and lost. It should be noted that, depending on the type of CAC procedure, different values of ECR may be derived for each ATM connection. The ECR of a connection derived by a certain CAC procedure may take the same value regardless of the expected traffic mix in the VPC/bandwidth module. The ECR derived by another CAC procedure may vary with the expected traffic mix, but given an expected traffic mix, it takes a fixed value [RMV]. According to yet another CAC procedure, the value of ECR for a connection can depend on the actual traffic. The latter case is not considered in this Recommendation. Furthermore, required accuracy of ECR depends on the applications. A certain procedure may derive an ECR for dimensioning purposes only.

### 9.1.2 Assumptions

We assume the following:

- 1) the offered traffic mix is the same for all the VPCs/bandwidth modules in the VPC/bandwidth module group;
- 2) the same cell level performance objectives are applied to all the connections routed to the group;
- 3) the ECRs of arriving connections are the same for all the VPCs/bandwidth modules in the group.

Regarding assumption 3), in the case where the ECR of every connection is the same for all VPCs/bandwidth modules in the group (e.g. DBR or uncontrolled constant rate VPCs with the same capacity, or variable rate VPCs carried on links with the same capacity), no approximation is needed. Otherwise, a weighted value of ECR may be used as an approximation. The details of the approximation need further study.

The CAC of each VPC/bandwidth module in the group is made by checking the following equation:

$$\Sigma(\text{ECRs of connections in the VPC/bandwidth module}) + \text{ECR of the arriving connection} \leq \text{bandwidth of the VPC/bandwidth module.} \quad (9-1)$$

If the inequality is true, the arriving connection is accepted by the VPC/bandwidth module, and otherwise, it is rejected.

It is thus assumed that the decision of acceptance and rejection of a connection at the group can be represented by:

$$\Sigma(\text{ECRs of the connections in the group}) + \text{ECR of the arriving connection} \leq \text{bandwidth of the group.} \quad (9-2)$$

Note that the connection is established at one of the VPCs/bandwidth modules in the group.

An arriving connection may have an ECR which is greater than the free bandwidth in each VPC/bandwidth module while being smaller than the total free bandwidth in the group. This connection would be rejected in the real system, while being accepted by the proposed approximation. Further studies are required for this boundary problem.

### 9.1.3 Bandwidth quantization

The range of ECRs computed for ATM connections can be large. For dimensioning purposes, depending on methods, it is necessary to find an appropriate bandwidth quantization unit (e.g. 64 kbit/s), depending on the assumed traffic mix. Let  $e$  denote the bandwidth quantization unit. Then, for an ECR  $b$  of an ATM connection, the discretized bandwidth  $m$  is the smallest integer not less than  $b/e$ . The bandwidth of the VPC/bandwidth module or VPC/bandwidth module group may also be discretized with the same quantization unit  $e$ .

Note, however, that an error in the ECR of the connections is introduced by the quantization and that the larger is the quantization unit, the larger is the error. The impact of the quantization error on the result of dimensioning a VPC/bandwidth module group can be alleviated by adjusting the values of mean arrival rates or mean holding times of the connections to maintain the mean offered load of each connection type.

### 9.1.4 Connection blocking probability

The connection level performance parameter relevant for traffic engineering is the connection blocking probability. For dimensioning purposes, cell level performance parameters are taken into account by the ECR of the connections.

### 9.1.5 Connection level traffic controls

Blocking probabilities of connections sharing the same VPC/bandwidth module group may vary largely with the type of connection. This is because the connections may require different amounts of resources at the VPC/bandwidth module group, and calculated ECRs may take values in a wide range. In order to achieve an appropriate connection level performance of the VPC/bandwidth module group in an economical way, connection level traffic controls such as bandwidth reservation may be used at the VPC/bandwidth module group to improve blocking probabilities.

## 9.2 Principles of the dimensioning method

The purpose of dimensioning the VPC/bandwidth module group described above is to find an optimal bandwidth of the VPC/bandwidth module group and corresponding optimal set of capacity parameter values of the VPC/bandwidth module in the group to satisfy given GOS objectives for an assumed offered traffic. As stated in Recommendation E.735, an iterative procedure is suitable for dimensioning the VPC/bandwidth module group because the resources to be allocated to the connections depend on both the traffic parameters of the connections and the capacity of the VPC/bandwidth module group.

The objective of dimensioning the VPC/bandwidth module group is to find the least amount of bandwidth of the group meeting GOS requirements. The basic iterative procedure is as follows:

#### Step 1): Initialization

Assign an appropriate amount of bandwidth to the VPC/bandwidth module group. Set also the parameter values of connection level traffic controls such as bandwidth reservation, if necessary.

## Step 2): Evaluation of ECR

Compute an ECR for each connection type taking into account the traffic parameters of the connections and the capacity parameters of the VPC/bandwidth module or, in case of a variable rate VPC, the capacity parameters of the links. For this purpose, an assumption has to be made on the partition of the bandwidth of the group into VPCs/bandwidth modules or, in case of a variable rate VPC, on the capacities of the links on which VPCs/bandwidth modules are carried.

## Step 3): Evaluation of connection blocking probabilities

Compute the connection blocking probabilities of connections at the VPC/bandwidth module group.

## Step 4): Iteration

Modify the amount of bandwidth and connection level traffic control parameters and iterate Steps 2) and 3) until an optimal solution is reached.

For rate sharing multiplexing (see Recommendation E.736), there are definitions of ECR that are independent of the link or VPC bandwidth (but dependent on buffer capacity), in which case the value of ECR does not need to be updated in the above iteration. Also note that for variable rate VPCs, the ECR of the VCCs depends on the link capacity and not on the VPC capacity and thus updating the ECRs is not necessary in the iterations.

## 9.3 Computing connection blocking probabilities of a VPC/bandwidth module group

Computation of connection blocking probabilities of the VPC/bandwidth module group is based on an analysis of the state space of the VPC/bandwidth module group and computing steady-state probabilities of the states in which connection requests are rejected.

### 9.3.1 State space analysis

Let  $\Gamma$  denote a set of different connection streams offered to the concerned VPC/bandwidth module group, and let  $b_k$  denote the ECR computed for the connection in stream  $k \in \Gamma$  at the VPC/bandwidth module group. Further, let  $n_k$  denote the number of stream  $k$  connections in progress at the VPC/bandwidth module group. The state of the VPC/bandwidth module group is thus expressed by a vector  $n = (n_k : k \in \Gamma)$ . For an assumed CAC procedure and a given connection level traffic control scheme, it is possible to specify a state space of the VPC/bandwidth module group, denoted by  $\Omega$  by considering the bandwidth  $C$  of the VPC/bandwidth module group and the ECR  $b_k$  of connections, so that, in any state  $n$  in  $\Omega$ , the cell level GOS objectives of all connections of the VPC/bandwidth module group are satisfied simultaneously.

By using the call arrival rate and mean holding time of each connection stream, it is possible to define state transitions in the space  $\Omega$ . Use of connection level traffic control schemes is reflected in the state transitions in such a way that state transitions are selectively limited or regulated. By analysing the obtained state space, the state probabilities and thus the connection blocking probabilities of individual streams may be computed. In some cases, the state probabilities have the product form, e.g. [KAU], [ROB] and [DZI].

### 9.3.2 Dimensioning with fixed ECR

In case where the ECR of each connection takes a positive fixed value for any state  $n$ , the state space  $\Omega$  of the VPC/bandwidth module group has the same structure as in the multi-slot traffic model. Therefore, for computing the connection blocking probabilities  $B_k$  for the VPC/bandwidth module group, analytical methods for a multi-slot connection model described in Recommendations E.526 and E.731 may be applied. Other methods for this purpose can be found in [RMV].

Annex A gives the principles of some example methods.

### 9.3.3 Dimensioning under adaptive CAC

Further study is needed to efficiently cope with the case where ECR is state-dependent.

## 10 Dimensioning a network

In this clause, dimensioning methods for a network are presented.

### 10.1 Principles of network dimensioning methods

The dimensioning elements of the network are summarized in clause 5. The design variables considered in this Recommendation are:

- size of each link set: the number of ATM links and the bandwidth of each ATM link in each ATM link set;
- size of VPCs and bandwidth modules;
- assignment of VPCs/bandwidth modules to VPC/bandwidth module groups;
- assignment of VPCs and bandwidth modules to ATM links;
- parameters of call and connection level traffic controls (e.g. traffic routing, service protection schemes) employed in the network.

We consider the case where the capacity of every link, VPC and bandwidth module in the network is defined by an amount of bandwidth. In this case, the objective of the dimensioning may be to find the optimal amount of bandwidth of each together with an assignment of VPCs and bandwidth modules to the physical network and an evaluation of the call and connection level traffic control parameters. It is assumed that call and connection level traffic control schemes are selected at the initial stage of the dimensioning process and remain fixed in the studied network model.

The basic problem of network dimensioning in this context is formulated as the following non-linear optimization problem:

Given: traffic demand matrices and other assumptions to construct a network model;

Design variables: a vector  $\mathbf{v}$  whose elements represent each design variable;

Objective: minimize  $z = z(\mathbf{v})$ ;

Constraints:  $B_k \leq \bar{B}_k$ , for every traffic stream  $k$  in the network;

where  $B_k$  and  $\bar{B}_k$ , denote the traffic stream  $k$  end-to-end call/connection blocking probability and its objective value, respectively. The objective function  $z = z(\mathbf{v})$  will be chosen based on network operator's policy and other factors. For example, the function may represent the total cost of the network in some applications, e.g. [MEN]. The function may be selected to find a solution which maximizes the total carried traffic weighted by stream-by-stream unit revenue, e.g. [FAR], [GIR] and [MI2].

As for the dimensioning process for a single VPC/bandwidth module group given in 9.2, an iterative approach is appropriate for the network dimensioning process. This is mainly because the resources to be allocated to connections depend on the capacity of the VPCs/bandwidth modules in the network as well as the traffic parameters of the connections. Furthermore, iterative optimization methods such as the steepest descent method are often used to solve non-linear optimization problems. There may be various iterative methods that can be applied to the network dimensioning problem. The basic procedure of single iteration process is as follows:

#### Step 1): Initialization

As an initial solution:

- set an appropriate number of links and their bandwidth between each appropriate pair of nodes;
- set an appropriate number of VPCs between each appropriate pair of nodes, and assign each VP link to an appropriate link in the physical network;

- assign an appropriate amount of bandwidth to every VPC and bandwidth module and assign them to the VPC/bandwidth module groups;
- set also the parameter values of call and connection level traffic controls such as call/connection routing and bandwidth reservation, if necessary.

### **Step 2): Evaluation of ECR**

Compute the ECR of every connection in every call at every VPC/bandwidth module group through which the connection can be established, taking into account the traffic parameters of connections and the capacity parameters of the VPCs/bandwidth modules or, in the case of a variable rate VPC, the capacity parameters of the links.

### **Step 3): Evaluation of call/connection blocking probabilities**

Compute end-to-end call/connection blocking probabilities for every traffic stream in the network.

### **Step 4): Iteration**

Modify the amount of bandwidth and the parameters of call/connection level traffic control schemes, and iterate steps 2) and 3) until a feasible solution satisfying the GOS objectives is reached.

The following points regarding the above procedure should be noted:

- 1) Due to hardware limitation, the modularity of a transmission path in the physical network may be taken into account in selecting the capacity parameter values of the links in steps 1) and 4).
- 2) The constraint that the sum of the bandwidths of VPCs/bandwidth modules on a link cannot exceed the link capacity must be taken into account in steps 1) and 4).

Examples of a specific optimization problem and optimization technique can be found in the literature, e.g. [FAR], [MEN] and [MI2].

## **10.2 Principles of end-to-end blocking calculation methods**

### **10.2.1 State space analysis**

Computation of end-to-end call/connection blocking probabilities could be based on a state space analysis of the network. For the purpose of computing the blocking probabilities, a vector, each of whose elements represents the number of calls/connections in progress of one of the call/connection streams in the network, is usually taken as the state of the network. In general, there are various ways of specifying network states and state space depending on the purpose of applications. Usually, it may be possible to specify a state space and state transitions in the space by considering the characteristics of call demand types and the call and connection level traffic controls employed. By analysing the steady-state probabilities of the network, the call/connection blocking probabilities of individual traffic streams may be computed. In some cases, the state probabilities have the product-form.

In the case that, as in PSTN and N-ISDN, all the calls offered to the network are symmetrical, that is, a call requests a pair of connections with the same bandwidth and holding time in forward and backward directions, and connection routing is performed in such a way that a pair of connections is established at a pair of corresponding forward and backward VPC/bandwidth module groups, it is not necessary to distinguish between the directions of transmission in the network in the process of state space analysis. Such a simplification may also be applied in more general cases if it is appropriate not to distinguish between the two directions.

### **10.2.2 Fixed point method**

#### *a) Principle*

In general, difficulty in computation may arise due to the large dimension of the state space of the networks, particularly, in cases where the product-form solution is not available. This motivates the necessity of approximate methods for computing end-to-end network blocking probabilities. The fixed point method (also known as the reduced load approximation), e.g. [WHI], [KEL], [DZI], [CHU] and [COY] is a fundamental technique which is usually used for computing approximate end-to-end call/connection blocking probabilities in a network dimensioning process.

The principle of the fixed point method is to decompose the network into its components, to analyse each of the components separately and then to derive the target performance measures of the network from the performance measures of the components. In the network models treated in this Recommendation, a VPC group and bandwidth module group will be considered as a basic component. A set of multiple VPC/bandwidth module groups in the network may be chosen as a component if appropriate. The fixed point method is based on the following two assumptions:

1) Independence assumption among components:

It is assumed that the components in the network are statistically independent, that is, events such as call and connection acceptance at one component are statistically independent of call and connection acceptance at other components in the network.

2) Hypothetical traffic offered to components:

In order to evaluate the performance of a component, it is assumed that a hypothetical traffic is offered to the component. The hypothetical traffic variables such as arrival rate are derived from the traffic characteristics of the original traffic assumption, the performance of the other components and traffic routing among the components.

It should be noted that the traffic characteristics of the components are related to each other through the hypothetical traffic assumed at the components. Thus, for a vector of performance measure  $\mathbf{u} = (u_j)$  where  $u_j$  represents the performance measure of component  $j$ , it is possible to derive an equation in the form of  $\mathbf{u} = \mathbf{F}(\mathbf{u})$ . To solve this equation, an iterative procedure is usually used, and as a result, the approximate traffic characteristics of each component may be computed. There may be various alternative techniques for numerical computation of the iterative procedure, and they may have different convergence characteristics. Note that convergence is not guaranteed, but it is usually obtained in practical cases. Numerical computation methods and their convergence characteristics are outside of the scope of this Recommendation.

b) *Decomposition of network*

In using the fixed point method, it is crucial to find an appropriate decomposition of the network into components [COY]. The choice of components should be made by noting that the technique is based on the assumption that the chosen components would be statistically independent of each other. Furthermore, the choice of components has an impact on the computation time for evaluating target performance measures. It is, therefore, a usual practice that decompositions will be chosen taking account of a trade-off between the estimated level of accuracy and computation time.

For example:

- 1) In the case where it is assumed that all VPC/bandwidth module groups are mutually independent, the network will be decomposed into its VPC/bandwidth module groups, that is, the VPC/bandwidth module groups are each taken as an independent component. In case of a VPC group formed by variable rate VPCs, the group could be further decomposed into smaller independent components, each component corresponding to the set of VP links of the VPCs of the group in each of the ATM link sets on which the VPC group is established.
- 2) In the case where, as in PSTN and N-ISDN, corresponding forward and backward VPC/bandwidth module groups are statistically identical, it may be sufficient for network dimensioning purposes to consider only one of the directions of transmission. If the VPC/bandwidth module groups in the selected direction are assumed to be mutually independent, then the network will be decomposed into VPC/bandwidth module groups neglecting their direction of transmission.
- 3) Decomposition examples 1) and 2) may be applied to a network in a mixed manner.

Note also that, to simplify blocking computation, a VPC/bandwidth module group predefined from the viewpoint of traffic routing may be further divided into disjoint groups for each of which the assumptions stated in 9.1.2 are considered to be valid. This approach has the drawback of assuming independence among the resulting groups. This subdivision of VPC/bandwidth module groups is only for network dimensioning purposes.

The general iterative method given in 10.1 applies to all three of the above example decompositions. If example 2) does not pertain, then VPC/bandwidth module groups for both forward and backward directions are explicitly and separately included in the iteration. Also, each decomposition example impacts the computation of blocking probabilities in step 3) of the iterative method. In decomposition examples 1) and 2), individual VPC/bandwidth module groups are tested for available capacity for arriving connection requests. The example blocking computations in Annex A are designed for this case.

More detailed guidelines for decomposing a network in the framework of the fixed point method are for further study.

### **10.3 Computing blocking probabilities for a network with type A calls**

This subclause provides methods for computing end-to-end call/connection blocking probabilities of type A calls taking into account assumed routing schemes. The methods presented here are approximate ones based upon the fixed point modelling technique.

It is apparent that end-to-end call/connection blocking probabilities are highly dependent on what routing patterns are used for each call and connection in the call. If a pair of forward and backward connections are requested for a call, as supported by the B-ISDN Signalling CS-1, the pair of connections will be established, if accepted, through a pair of forward and backward VPCs/bandwidth modules with the same VPI at every B-ISDN INI according to the rule specified in Recommendation I.150. In this case, therefore, if either of the two connections is rejected at a VPC/bandwidth module group in a chosen route, then both connections may be re-routed to another pair of forward and backward VPC/bandwidth module groups or routes<sup>4</sup>. Thus, route and VPC/bandwidth module selection for connections within a call may not be independent in some networks. Such a dependency in connection routing should be reflected in constructing a network design model for computing end-to-end blocking probabilities.

Furthermore, as stated in 10.2, if VPC/bandwidth module groups in forward and backward directions of transmission are statistically dependent, the dependency should also be reflected in the network design model.

#### **10.3.1 End-to-end call blocking probabilities in a network with the load sharing routing scheme**

Subclause B.1 gives an example application of the fixed point method to a network with the load sharing routing scheme. In this example, it is assumed that all the VPC/bandwidth module groups in the network are independent. This example can also be applied to the case where it is sufficient to consider either of two directions of transmission in the network.

#### **10.3.2 End-to-end call blocking probabilities in a network with alternative routing schemes**

Subclause B.2 gives an example application of the fixed point method to a network with an alternative routing scheme. Recommendation E.170 gives the principle of alternative routing. In this example, it is assumed that it is sufficient from the viewpoint of traffic engineering to consider either of the forward and backward VPC/bandwidth module groups for computing end-to-end call/connection blocking probabilities. This is the case when the forward and backward directions of transmission in the network are statistically identical as in PSTN and N-ISDN.

#### **10.3.3 End-to-end call blocking probabilities in a network with other routing schemes**

This point requires further study.

---

<sup>4</sup> B-ISDN signalling allows coordination of establishing the forward and backward connections in such a way that, when adequate free resources are not found for one of the two connections in a chosen pair of forward and backward VPCs/bandwidth modules, the connections may be re-routed to another pair of forward and backward VPCs/bandwidth modules with the same VPI, if available, in the group or otherwise to another pair of forward and backward VPC/bandwidth module groups or routes (see Recommendation Q.2764).



## **10.4 Computing blocking probabilities for a network with type B calls**

This subclause provides methods for computing end-to-end call/connection blocking probabilities of type B calls taking into account assumed routing schemes. The methods presented here are approximate, being based on the fixed point modelling technique.

Connection routing for a type B call may involve:

- 1) routing of the first connection from the root node to the first leaf node; and
- 2) routing of the subsequent connections from the branching node to the remaining leaf nodes.

It is apparent that routing schemes used for the calls have a significant impact on end-to-end call and connection blocking probabilities.

### **10.4.1 End-to-end call blocking probabilities in a network with the load sharing routing scheme**

Annex C gives an example where the fixed point method is used to compute call/connection blocking probabilities in a network in which routing of the entire tree connection is of load sharing type. It is assumed in this example that the VPC/bandwidth module groups in the network are all independent [OD2].

### **10.4.2 End-to-end call blocking probabilities in a network with other routing schemes**

This point requires further study.

## **10.5 Computing blocking probabilities for a network with other call types**

Further study is required.

## **11 History**

This is the first issue.

## **Annex A**

### **Example calculation methods for individual blocking probabilities at a VPC/bandwidth module group**

This Annex provides a table of methods for computing individual blocking probabilities at a single VPC/bandwidth module group and describes the most relevant. The table is not intended to provide an exhaustive list of available methods.

#### **A.1 Summary of methods**

Table A.1 tabulates methods which can be used to model a single VPC/bandwidth module group.

**Table A.1/E.737 – Blocking calculation methods for a single VPC/bandwidth module group**

<b>Assumptions</b>	<b>Methods</b>
<ul style="list-style-type: none"> <li>– Poisson inputs</li> </ul>	<ul style="list-style-type: none"> <li>– Product-form solution (exact solution).</li> <li>– Kaufman-Roberts method (exact solution) (see A.3).</li> <li>– Hayward-type method – [LIN], [MEN] (see A.4).</li> <li>– Asymptotic approximation [MI1], [LAB].</li> </ul>
<ul style="list-style-type: none"> <li>– Poisson inputs</li> <li>– Bandwidth reservation</li> </ul>	<ul style="list-style-type: none"> <li>– Kaufman-Roberts method [ROB] (see A.3).</li> <li>– Hayward-type method (for the case of blocking equalization) [LIN], [MEN] (see A.4).</li> <li>– Heavy traffic approximation method [RMV].</li> </ul>
<ul style="list-style-type: none"> <li>– Poisson inputs</li> <li>– Bandwidth reservation</li> <li>– Bandwidth negotiation</li> </ul>	<ul style="list-style-type: none"> <li>– Kaufman-Roberts method (see Recommendation E.731) [OD2].</li> </ul>
<ul style="list-style-type: none"> <li>– Non-Poisson inputs</li> </ul>	<ul style="list-style-type: none"> <li>– Erlang method (for composite traffic) with transformation [RMV].</li> <li>– Kaufman-Roberts method (for time congestion) with transformation [RMV].</li> <li>– Delbrouck method (for time congestion) with transformation to call congestion [RMV].</li> <li>– Hayward-type method [MEN] (see A.4).</li> </ul>
<ul style="list-style-type: none"> <li>– Non-Poisson inputs</li> <li>– Bandwidth reservation</li> </ul>	<ul style="list-style-type: none"> <li>– Hayward-type method (for the case of blocking equalization) [LIN], [MEN] (see A.4).</li> </ul>

## **A.2 Notation**

The following notation is used throughout this Annex:

- $N$ : bandwidth of the VPC/bandwidth module group expressed as an integer number of bandwidth units;
- $k$ :  $k$ -th connection stream, where  $k = 1, 2, \dots, K$ ;
- $\lambda_k$ : connection arrival rate of stream  $k$ ;
- $\mu_k$ : reciprocal of the mean holding time of connection in stream  $k$ ;
- $m_k$ : ECR of a connection in stream  $k$  on the VPC/bandwidth module group expressed as an integer number of bandwidth units;
- $a_k$ : mean number of stream  $k$  connections in the hypothetical infinite capacity system, which is given by  $a_k = \lambda_k / \mu_k$ ;
- $v_k$ : variance of the number of connections in stream  $k$  in the hypothetical infinite capacity system (when Poisson input,  $v_k = a_k$ );
- $z_k$ : peakedness factor of stream  $k$ , which is given by  $z_k = v_k / a_k$ ;
- $\theta_k$ : bandwidth reservation parameter which indicates that a connection in stream  $k$  is accepted only if at least  $(\theta_k + m_k)$  bandwidth units of the VPC/bandwidth module group are idle when the connection arrives, where  $\theta_k$  is a non-negative integer;
- $B_k$ : blocking probability of stream  $k$ ;
- $E(\bullet, \bullet)$ : Erlang B formula.

### A.3 Kaufman-Roberts method

Consider a VPC/bandwidth module group with Poisson inputs with or without bandwidth reservation. This method is based on the following recurrence relation [KAU], [ROB] and [CHU]:

$$ip(i) = \sum_{k=1}^K \frac{\lambda_k m_k \zeta_k(i - m_k)}{\mu_k} p(i - m_k), \quad i = 1, 2, \dots, N \quad (\text{A-1})$$

$$\sum_{i=1}^N p(i) = 1 \quad (\text{A-2})$$

where  $i$  and  $p(i)$  denote the number of busy bandwidth units and the approximate probability distribution of that number in the VPC/bandwidth module group, respectively.  $\zeta_k(i - m_k)$  denotes the rate modification function which is derived taking account of the bandwidth reservation and is expressed as follows:

$$\zeta_k(i - m_k) = \begin{cases} 1 & \text{for } m_k \leq i \leq N - \theta_k \\ 0 & \text{for } N - \theta_k + 1 \leq i \leq N, \text{ for all } k \end{cases} \quad (\text{A-3})$$

The blocking probability  $B_k$  for stream  $k$  connection is given by:

$$B_k = \sum_{i=N-\theta_k-m_k+1}^N p(i), \text{ for all } k \quad (\text{A-4})$$

This method yields an exact solution which is of product-form when bandwidth reservation is not applied.  $B_k$  gives an approximation of the individual blocking probability when bandwidth reservation is applied.

Note that the state probabilities  $p(n)$  in formula A-1 do not vary with the service rate  $\mu_k$  as long as the traffic load  $\lambda_k / \mu_k$  is kept constant, while, in reality, the blocking probabilities at a VPC/bandwidth module are sensitive to the mean holding times of offered traffic when bandwidth reservation is applied [RMV]. In this case, the use of the following hypothetical service rate  $\mu$  instead of the actual service rate  $\mu_k$  is suggested:

$$1/\mu = \frac{\sum_{k=1}^K \lambda_k m_k (1/\mu_k)}{\sum_{k=1}^K \lambda_k m_k} \quad (\text{A-5})$$

### A.4 Hayward-type method

The principle of this method is to first compute the blocking probability  $B_0$  of a hypothetical composite traffic stream by using the Hayward-type approximation method and then to compute approximate individual blocking probabilities  $B_k$  from the blocking probability  $B_0$ .

For simplicity, assume that the minimum connection bandwidth is equal to one.

In the first step, the composite traffic is represented by the mean  $a$  and variance  $v$  of the number of bandwidth units occupied in the hypothetical infinite capacity system, which are given by the following equations:

$$a = \sum_{k=1}^K a_k m_k, \text{ and } v = \sum_{k=1}^K v_k (m_k)^2 \quad (\text{A-6})$$

To compute the blocking probability  $B_0$  of the composite traffic, the following equation is used:

$$B_0 = E(a/z, (N - z + 1)/z) \quad (\text{A-7})$$

where  $z = v/a$ . Note that  $B_0$  gives an approximation to the mean blocking probability of the  $K$  streams.

In the second step, the approximate individual blocking probabilities are given by the following transformation:

$$B_k = B_0(1 - B_0) \frac{(N/a)^{m_k z_k / z} - 1}{N/a - 1}, \text{ for all } k \quad (\text{A-8})$$

When bandwidth reservation is applied to equalize the individual blocking probabilities, the approximate blocking probabilities are given by:

$$B_k = E(a/z, (N - m_{\max} + 1)/z), \text{ for all } k \quad (\text{A-9})$$

where  $m_{\max}$  denotes the maximum of the bandwidth of connections.

## Annex B

### An example method for computing blocking probabilities for a network with type A calls

#### B.1 Example with the load sharing routing scheme

##### B.1.1 Network model

Consider a network model with input of type A calls and the load sharing routing scheme. In this example, there is a correspondence between the route chosen by a connection and the route chosen by the other connections of the same call. When a call consists of multiple connections, we use the expression "a route set for the call" to mean a route for each connection of the call. A particular choice of "a route set for the call" consists of a particular choice of a route for each connection of the call. In particular, "the  $q$ -th route set of a call is chosen" means "each connection of the call chooses its  $q$ -th route". The following notations are used:

- $s$ :  $s$ -th call stream in the network, where  $s = 1, 2, \dots, S$ ;
- $k$ :  $k$ -th connection of a call in stream  $s$ , where  $k = 1, 2, \dots, K_s$ ;
- $\lambda_s$ : arrival rate of call stream  $s$ ;
- $q$ :  $q$ -th route set for a call in stream  $s$ , where  $q = 1, 2, \dots, Q_s$ ;

$G(s,q,k)$ : the set of VPC/bandwidth module groups included in the  $q$ -th route for the  $k$ -th connection of call stream  $s$ ;

$G(s,q)$ : the set of all the VPC/bandwidth module groups included in route set  $q$  for call stream  $s$  [i.e.  $G(s,q) = \bigcup_{k=1}^{K_s} G(s,q,k)$ ];

$r_{sq}$ : the probability that route set  $q$  is selected for an arriving new call in stream  $s$ , where  $\sum_{q=1}^{Q_s} r_{sq} = 1$ .

The following routing rule is assumed in the network:

- 1) An arriving new call is randomly routed to route set  $q$  with probability  $r_{sq}$ .
- 2) If any connection of the call is blocked at its route of the selected route set, the call is lost and cleared.

Figure B.1 gives an example of route sets and the set of VPC/bandwidth module groups  $G(s,q,k)$ . Note that the routing scheme includes a fixed routing scheme as the special case that  $r_{sq} = 1$  for only one of the possible route sets.

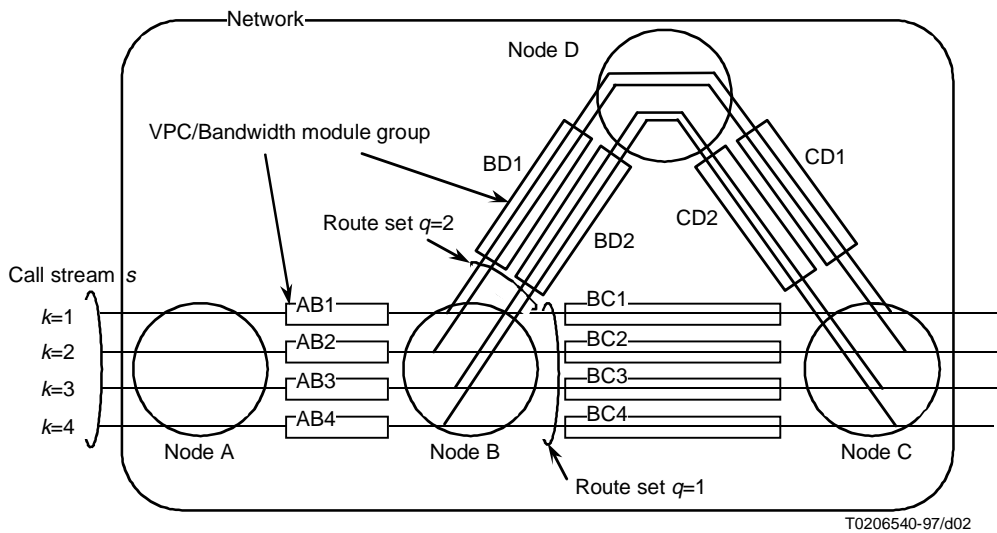

For a call stream  $s$ ,

VPC/bandwidth module group selection for connections in their routes  $q=1$ :

$$G(s,q=1, k=1) = \{AB1, BC1\},$$

$$G(s,q=1, k=2) = \{AB2, BC2\},$$

$$G(s,q=1, k=3) = \{AB3, BC3\},$$

$$G(s,q=1, k=4) = \{AB4, BC4\}.$$

$$G(s,q=1) = \{AB1, AB2, AB3, AB4, BC1, BC2, BC3, BC4\}.$$

VPC/bandwidth module group selection for connections in their routes  $q=2$ :

$$G(s,q=1, k=1) = \{AB1, BD1, CD1\},$$

$$G(s,q=1, k=2) = \{AB2, BD1, CD1\},$$

$$G(s,q=1, k=3) = \{AB3, BD2, CD2\},$$

$$G(s,q=1, k=4) = \{AB4, BD2, CD2\}.$$

$$G(s,q=2) = \{AB1, AB2, AB3, AB4, BD1, BD2, CD1, CD2\}.$$

**Figure B.1/E.737 – An example of route sets for a type A call**

### B.1.2 End-to-end call blocking probabilities

If it is assumed that VPC/bandwidth module groups in the network are all mutually independent, the network can be decomposed into the VPC/bandwidth module groups, by following the principle stated in 10.2.2. The connection blocking probabilities at each VPC/bandwidth module group are then computed by assuming that the ATM connection requests in a call arrive at the VPC/bandwidth module group with a hypothetical arrival rate independently of the other VPC/bandwidth module groups. The hypothetical arrival rates are derived taking account of the rate reduction from the original rate due to the connection blockings at the other VPC/bandwidth module groups.

In cases where more than one connection in a call may share a VPC/bandwidth module group, that is, there exists a VPC/bandwidth module group  $g$  such that  $g \in G(s, q, k_1)$  and  $g \in G(s, q, k_2)$  for some different connections  $k_1$  and  $k_2$  in a call, it may be necessary to take into account the simultaneity of arrivals of those connections  $k_1$  and  $k_2$  in computing their blocking probabilities on VPC/bandwidth module group  $g$ . For the purpose of computing end-to-end call blocking probabilities, a hypothetical single connection with an aggregated bandwidth of the concerned connections (e.g. connections  $k_1$  and  $k_2$  in the above) at the shared VPC/bandwidth module group may be used as a model to compute the probability that sufficient free bandwidth is available at the VPC/bandwidth module group at the arrival time of the considered connections.

Let  $\omega_{sq}^{(g)}$  denote the hypothetical arrival rate of a connection or hypothetical aggregated connection of a call in stream  $s$  at VPC/bandwidth module group  $g \in G(s, q)$ , where only this connection or hypothetical aggregated connection in the call is routed to the VPC/bandwidth module group  $g$  for the call establishment. This rate is given by the following:

$$\omega_{sq}^{(g)} = \lambda_s r_{sq} \frac{\prod_{h \in G(s, q)} (1 - B_{sq}^{(h)})}{1 - B_{sq}^{(g)}}, \text{ for every } s, q, \text{ and } g \in G(s, q) \quad (\text{B-1})$$

where  $B_{sq}^{(g)}$  denotes the blocking probability of the hypothetical connection of call stream  $s$  at VPC/bandwidth module group  $g$ . Based on this theory, the connection blocking probabilities and the reduced arrival rates are computed iteratively. The factors  $(1 - B_{sq}^{(h)})$  of formula B-1 are important when an overloaded network is analysed. In dimensioning, when the target blocking probability is very small [say,  $B_{sq}$  and thus one minus the product of the factors  $(1 - B_{sq}^{(h)})$  in the order of 1%], the factors  $(1 - B_{sq}^{(h)})$  might be taken equal to 1 as a safe side approximation<sup>5</sup>. Thus, formula B-1 becomes:

$$\omega_{sq}^{(g)} = \lambda_s r_{sq}, \text{ for every } s, q, \text{ and } g \in G(s, q) \quad (\text{B-2})$$

The use of the simplified formula B-2 avoids the need for iterations between the connection blocking probabilities and the hypothetical arrival rates. For the computation of the connection blocking probabilities  $B_{sq}^{(g)}$ , the methods stated in 9.3 can be used. It should be noted that the ECR of a connection may vary with VPC/bandwidth module groups on the route for the connection. Once the connection blocking probabilities at every VPC/bandwidth module group are obtained, the call blocking probability  $B_{sq}$  at route set  $q$  and the total call blocking probability  $B_s$  of call stream  $s$  can be computed by the following equations:

$$B_{sq} = 1 - \prod_{g \in G(s, q)} (1 - B_{sq}^{(g)}) \quad (\text{B-3})$$

$$B_s = \sum r_{sq} B_{sq} \quad (\text{B-4})$$

---

<sup>5</sup> Furthermore, the factors  $(1 - B_{sq}^{(h)})$  must be used with caution when a part of the network is being dimensioned and another part of the network is overloaded. It may not be prudent to dimension a VPC/bandwidth module group  $g$  relying on an arrival rate  $\omega_{sq}^{(g)}$  reduced due to present overload of another VPC/bandwidth module group  $h$ , since the overload of group  $h$  could be removed in the future.

Formula B-3 is derived from the assumption that a type A call is accepted only if all the connections in the call are accepted.

The method consisting of the fixed point method and the analysis of the multi-slot connection model may be used for the network in which both bandwidth negotiation and reservation are applied simultaneously. If a connection is routed to a route consisting of more than one VPC/bandwidth module group in tandem, results of bandwidth negotiation at VPC/bandwidth module groups must be aligned through the route [OD2].

## B.2 Example with an alternative routing scheme

### B.2.1 Network model

For simplicity, consider a network model in which every call requests only a pair of forward and backward connections and, for each call stream, only one VPC/bandwidth module group can be chosen at any VPC/bandwidth module set and assume for the purpose of call blocking calculation, that it is sufficient to consider either of the two directions of transmission in the network. The following notations are used:

- $s$ :  $s$ -th call stream, where  $s = 1, 2, \dots, S$ ;
- $q$ :  $q$ -th route for the considered connection (i.e. for the connection in the considered direction of transmission) of a call in stream  $s$ , where  $q = 1, 2, \dots, Q_s$ ;
- $j$ :  $j$ -th VPC/bandwidth module group in route  $q$  for stream  $s$ ;
- $B_{sqj}$ : call blocking probability at  $j$ -th VPC/bandwidth module group in route  $q$  for stream  $s$ ;
- $RB_{sq}$ : call blocking probability at route  $q$  for stream  $s$ ;
- $B_s$ : end-to-end call blocking probability of stream.

Regarding call routing, it is assumed that a direct path is chosen first and two-link routes (i.e. a concatenation of two VPC/bandwidth module groups) are used as an alternative route (i.e.  $j = 1, 2$ ). It is also assumed that the two-link routes for a call stream are link disjoint, that is, no route shares the same VPC/bandwidth module group with any other routes. The following routing rule is assumed:

- 1) For a call stream, a sequence of routes is specified.
- 2) An arriving new call is routed to the route following its route sequence. When the call is blocked at a route, then it overflows to the next route.
- 3) If the call is blocked at the last route in the sequence, it is lost and cleared.

### B.2.2 End-to-end call blocking probabilities

Assuming that the VPC/bandwidth module groups are mutually independent, the call blocking probability on a route  $RB_{sq}$ , is approximately given as follows:

$$RB_{sq} = \begin{cases} B_{sq1}, & \text{for all } s, q = 1 \\ 1 - \prod_{j=1}^2 (1 - B_{sqj}), & \text{for all } s, q > 1 \end{cases} \quad (\text{B-5})$$

**Case 1)** For a call stream for which no crankback (see Recommendation E.170) is not used at any transit node, end-to-end call blocking probability  $B_s$  is approximately given by:

$$B_s = 1 - \sum_{q=1}^{Q_s} (1 - RB_{sq}) \prod_{h=1}^{q-1} B_{sh1}, \quad \text{for all } s \quad (\text{B-6})$$

**Case 2)** For a call stream for which crankback (see Recommendation E.170) is used at all transit nodes, the end-to-end call blocking probability  $B_s$  is approximately given by:

$$B_s = \prod_{q=1}^{Q_s} RB_{sq}, \quad \text{for all } s \quad (\text{B-7})$$

**Case 3)** For a call stream for which crankback is used partially, the end-to-end call blocking probability  $B_s$  is approximately expressed in a mixed manner between the above two extremes.

In order to calculate the call blocking probability  $B_{sqj}$  at a VPC/bandwidth module group, the fixed point method will be used with the calculation of a hypothetical arrival rate to the VPC/bandwidth module group for each stream. The hypothetical arrival rate may be calculated by taking account of blocking probabilities at the preceding routes and the other VPC/bandwidth module groups in the route in which the VPC/bandwidth module group of concern is included. The methods in 9.3 can be used to compute the call blocking probabilities  $B_{sqj}$ .

It should be noted that overflow traffic from a route is not Poissonian. If the variance of the overflow traffic streams is derived, the methods in Annex A which use both means and variances of traffic streams can be applied to compute the call blocking probabilities of the overflow routes to which the traffic streams overflowing from the preceding routes are input. A method to compute the variances and/or higher moments of overflows in the multi-slot connection model is available in [OD3]. Note, however, that the calculation of variances and blocking probabilities by using the variance information requires further computation time in the network dimensioning procedure. Further study is needed for methods to compute the variance of overflows efficiently.

## Annex C

### An example method for computing blocking probabilities for a network with type B calls

#### C.1 Example with load sharing routing scheme

##### C.1.1 Network model

Consider a network model with input of type B calls. In this example, since a call consists of multiple connections, the same concept of "route set for a call" as introduced in the example in B.1 is used to represent a correspondence among routes chosen by the connections in the call. The following notation is used to describe traffic relations:

$s$ :  $s$ -th call stream, where  $s = 1, 2, \dots, S$ ;

$K(s)$ : the entire set of leaves of a call in stream  $s$ ;

$k$ :  $k$ -th leaf in  $K(s)$ , where  $k = 1$  represents the leaf of the first connection;

$q$ :  $q$ -th route set for a call in stream  $s$ , where  $q = 1, 2, \dots, Q_s$ ;

$F(s,q)$ : the set of VPC/bandwidth module groups included in the  $q$ th route for the first connection of calls in stream  $s$ ;

$G(s,q,k)$ : the set of VPC/bandwidth module groups included in the  $q$ th route for the connection from a branching node to the leaf  $k$  ( $> 1$ ) of calls in stream  $s$ ;

$r_{sq}$ : the probability that route set  $q$  is selected for an arriving new call in stream  $s$ , where  $\sum_{q=1}^{Q_s} r_{sq} = 1$ .



The following routing rule is assumed in the network:

- 1) An arriving new call is randomly routed to route set  $q$  with probability  $r_{sq}$ .
- 2) If the first connection of a call is blocked on its route of the selected route set, the call is lost and cleared. If an additional connection is blocked at its route of the selected route set, only this connection is lost and cleared.

Figure C.1 gives an example of route sets,  $F(s,q)$  (the route for the first connection) and  $G(s,q,k)$  (the route for the  $k$ -th connection). Note that the routing scheme includes a fixed routing scheme as the special case where  $r_{sq} = 1$  for only one of the possible route sets.

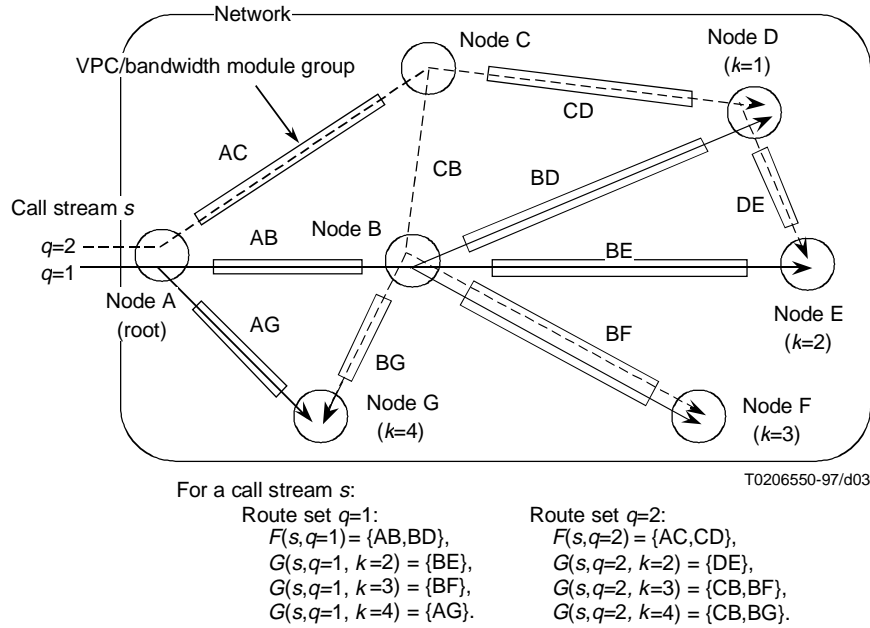

Figure C.1/E.737 – An example of route sets for a type B call stream

### C.1.2 End-to-end call and connection blocking probabilities

If it is assumed that the VPC/bandwidth module groups in the network are all mutually independent, the computation procedure based on the fixed point method may be applied by decomposing the network into the VPC/bandwidth module groups.

For simplicity, consider a special case where all the routes from branching nodes to additional leaves are disjoint, that is, the connections from the branching nodes to the additional leaves do not share any VPC/bandwidth module group. The blocking probability  $B_{sq}$  of the first connection can be computed by the same approximation method described in B.1 [formulae B-1, B-2 and B-3 can be used in this case by substituting  $G(s,q)$  by  $F(s,q)$ ], and this gives the call blocking probability of stream  $s$  routed to route set  $q$ . In this simple case, the connection blocking probability  $B_{sqk}$  for an additional leaf  $k (> 1)$  in a call in stream  $s$  routed to route set  $q$  may be computed approximately by using the following hypothetical arrival rate of the  $k$ -th additional connection to VPC/bandwidth module group  $g$  in  $G(s,q,k)$ :

$$\omega_{sqk}^{(g)} = \lambda_s r_{sq} (1 - B_{sq}) \frac{\prod_{h \in G(s,q,k)} (1 - B_{sqk}^{(h)})}{1 - B_{sqk}^{(g)}}, \text{ for every } s, q, k (\neq 1), \text{ and } g \in G(s,q,k) \quad (\text{C-1})$$

where  $B_{sqk}^{(g)}$  denotes the connection blocking probability on VPC/bandwidth module group  $g$ . The note given in B.1.2, paragraph four, on the need of the factors  $(1 - B_{sq}^{(h)})$  in case of dimensioning with low target blocking probability applies here to the factors  $(1 - B_{sqk}^{(h)})$ . An approximation to the connection blocking probability  $B_{sqk}$  is given by:

$$B_{sqk} = 1 - \prod_{g \in G(s,q,k)} (1 - B_{sqk}^{(g)}) \quad (\text{C-2})$$

## Appendix I

### Bibliography

- [CHU] CHUNG (S.P.), KASHPER (A.), ROSS (K.W.): Computing approximate blocking probabilities for large loss networks with state-dependent routing, *IEEE/ACM Trans. on Networking*, Vol. 1, No. 1, pp. 105-115, February 1993.
- [COY] COYLE (A.J.), HENDERSON (W.), TAYLOR (P.G.): Reduced load approximations for loss networks, *Telecommunications Systems*, Vol. 2, No. 1, pp. 21-50, December 1993.
- [DZI] DZIONG (Z.), ROBERTS (J.W.): Congestion probabilities in a circuit-switched integrated services network, *Performance Evaluation*, Vol. 17, pp. 267-284, 1987.
- [FAR] FARAGO (A.), BLAABJERG (S.), AST (L.), GORDOS (G.), HENK (T.): A new degree of freedom in ATM network dimensioning: optimizing the logical configuration, *IEEE JSAC*, Vol. 13, No. 7, pp. 1199-1206, September 1995.
- [GIR] GIRARD (A.), LESSARD (N.): Revenue optimization of virtual circuit ATM networks, *Proceedings of 5th Int'l Network Planning Symp.*, Kobe, May 1992.
- [KAU] KAUFMAN (J.S.): Blocking in a shared resource environment, *IEEE Trans. on Commun.*, Vol. 29, No. 10, pp. 1474-1481, October 1981.
- [KEL] KELLY (F.): Blocking probabilities in large circuit-switched networks, *Advances in Applied Probability*, Vol. 18, pp. 473-505, 1986.
- [LAB] LABOURDETTE (J.-F.P.), HART (G.W.): Blocking probabilities in multitraffic loss systems: insensitivity, asymptotic behaviour, and approximations, *IEEE Trans. on Commun.*, Vol. 40, No. 8, pp. 1355-1366, August 1992.
- [LIN] LINDBERGER (K.): Some ideas on grade of service and call scale link-by-link dimensioning, *10th Nordic Teletraffic Seminar*, 1992.
- [MEN] MENOZZI (M.), MOCCI (U.), SCOGLIO (C.), TONIETTI (A.): Traffic integration and virtual path optimization in ATM networks, *Proceedings of 6th Int'l Network Planning Symp.*, Budapest, September 1994.
- [MI1] MITRA (D.), MORRISON (J.A.): Erlang capacity and uniform approximations for shared unduffered resources, *IEEE Trans. on Networking*, Vol. 2, No. 6, pp. 558-570, December 1994.

- [MI2] MITRA (D.), MORRISON (J.A.), RAMAKRISHNAN (K.G.): Unified approach to multirate ATM network design and optimization, *Proceedings of 9th ITC Specialists Seminar*, pp. 77-94, Leidschendam, November 1995.
- [OD1] ODA (T.), WATANABE (Y.): Optimal trunk reservation for a group with multislot traffic streams, *IEEE Trans. on Commun.*, Vol. 38, No. 7, pp. 1078-1084, July 1990.
- [OD2] ODA (T.), NAKAMURA (H.): A traffic model for networks handling multimedia multi-connection calls, *Proc. of NETWORKS96*, Vol. 2, pp. 431-436, Sydney, November 1996.
- [OD3] ODA (T.): Moment analysis for traffic associated with Markovian queueing system, *IEEE Trans. on Commun.*, Vol. 39, No. 5, pp. 737-746, May 1991.
- [RMV] ROBERTS (J.W.), MOCCI (U.), VIRTAMO (J.) (Eds.): Broadband network teletraffic, *Lecture Notes in Computer Science*, Vol. 1155, Springer-Verlag, 1996.
- [ROB] ROBERTS (J.W.): Teletraffic models for the Telecom 1 integrated service network, *Proceedings of 10th ITC*, Paper 1.1.2, Montreal, 1983.
- [WHI] WHITT (W.): Blocking when service is required from several facilities simultaneously, *AT&T Technical Journal*, Vol. 64, No. 8, pp. 1807-1856, October 1985.



## ITU-T RECOMMENDATIONS SERIES

Series A	Organization of the work of the ITU-T
Series B	Means of expression: definitions, symbols, classification
Series C	General telecommunication statistics
Series D	General tariff principles
<b>Series E</b>	<b>Overall network operation, telephone service, service operation and human factors</b>
Series F	Non-telephone telecommunication services
Series G	Transmission systems and media, digital systems and networks
Series H	Audiovisual and multimedia systems
Series I	Integrated services digital network
Series J	Transmission of television, sound programme and other multimedia signals
Series K	Protection against interference
Series L	Construction, installation and protection of cables and other elements of outside plant
Series M	TMN and network maintenance: international transmission systems, telephone circuits, telegraphy, facsimile and leased circuits
Series N	Maintenance: international sound programme and television transmission circuits
Series O	Specifications of measuring equipment
Series P	Telephone transmission quality, telephone installations, local line networks
Series Q	Switching and signalling
Series R	Telegraph transmission
Series S	Telegraph services terminal equipment
Series T	Terminals for telematic services
Series U	Telegraph switching
Series V	Data communication over the telephone network
Series X	Data networks and open system communication
Series Z	Programming languages