



INTERNATIONAL TELECOMMUNICATION UNION

**ITU-T**

TELECOMMUNICATION  
STANDARDIZATION SECTOR  
OF ITU

**G.108.2**

(01/2003)

SERIES G: TRANSMISSION SYSTEMS AND MEDIA,  
DIGITAL SYSTEMS AND NETWORKS

International telephone connections and circuits – General  
definitions

---

**Transmission planning aspects of echo  
cancellers**

ITU-T Recommendation G.108.2

---

ITU-T G-SERIES RECOMMENDATIONS  
TRANSMISSION SYSTEMS AND MEDIA, DIGITAL SYSTEMS AND NETWORKS

INTERNATIONAL TELEPHONE CONNECTIONS AND CIRCUITS	G.100–G.199
<b>General definitions</b>	<b>G.100–G.109</b>
General Recommendations on the transmission quality for an entire international telephone connection	G.110–G.119
General characteristics of national systems forming part of international connections	G.120–G.129
General characteristics of the 4-wire chain formed by the international circuits and national extension circuits	G.130–G.139
General characteristics of the 4-wire chain of international circuits; international transit	G.140–G.149
General characteristics of international telephone circuits and national extension circuits	G.150–G.159
Apparatus associated with long-distance telephone circuits	G.160–G.169
Transmission plan aspects of special circuits and connections using the international telephone connection network	G.170–G.179
Protection and restoration of transmission systems	G.180–G.189
Software tools for transmission systems	G.190–G.199
GENERAL CHARACTERISTICS COMMON TO ALL ANALOGUE CARRIER-TRANSMISSION SYSTEMS	G.200–G.299
INDIVIDUAL CHARACTERISTICS OF INTERNATIONAL CARRIER TELEPHONE SYSTEMS ON METALLIC LINES	G.300–G.399
GENERAL CHARACTERISTICS OF INTERNATIONAL CARRIER TELEPHONE SYSTEMS ON RADIO-RELAY OR SATELLITE LINKS AND INTERCONNECTION WITH METALLIC LINES	G.400–G.449
COORDINATION OF RADIOTELEPHONY AND LINE TELEPHONY	G.450–G.499
TESTING EQUIPMENTS	G.500–G.599
TRANSMISSION MEDIA CHARACTERISTICS	G.600–G.699
DIGITAL TERMINAL EQUIPMENTS	G.700–G.799
DIGITAL NETWORKS	G.800–G.899
DIGITAL SECTIONS AND DIGITAL LINE SYSTEM	G.900–G.999
QUALITY OF SERVICE AND PERFORMANCE	G.1000–G.1999
TRANSMISSION MEDIA CHARACTERISTICS	G.6000–G.6999
DIGITAL TERMINAL EQUIPMENTS	G.7000–G.7999
DIGITAL NETWORKS	G.8000–G.8999

*For further details, please refer to the list of ITU-T Recommendations.*

## **ITU-T Recommendation G.108.2**

### **Transmission planning aspects of echo cancellers**

#### **Summary**

This Recommendation provides guidance for the transmission planning aspects in conjunction with the deployment of echo cancellers in the network.

Recognizing that echo cancellers are required on an increasing number of connections due to the increase of end-to-end delay by the introduction of speech processing techniques as well as of packet-based transportation mechanisms, this Recommendation is intended to assist network operators and transmission planners as well as equipment manufacturers and application designers in controlling the effects of echo cancellers on end-to-end speech transmission performance.

#### **Source**

ITU-T Recommendation G.108.2 was prepared by ITU-T Study Group 12 (2001-2004) and approved under the WTSA Resolution 1 procedure on 31 January 2003.

## FOREWORD

The International Telecommunication Union (ITU) is the United Nations specialized agency in the field of telecommunications. The ITU Telecommunication Standardization Sector (ITU-T) is a permanent organ of ITU. ITU-T is responsible for studying technical, operating and tariff questions and issuing Recommendations on them with a view to standardizing telecommunications on a worldwide basis.

The World Telecommunication Standardization Assembly (WTSA), which meets every four years, establishes the topics for study by the ITU-T study groups which, in turn, produce Recommendations on these topics.

The approval of ITU-T Recommendations is covered by the procedure laid down in WTSA Resolution 1.

In some areas of information technology which fall within ITU-T's purview, the necessary standards are prepared on a collaborative basis with ISO and IEC.

## NOTE

In this Recommendation, the expression "Administration" is used for conciseness to indicate both a telecommunication administration and a recognized operating agency.

Compliance with this Recommendation is voluntary. However, the Recommendation may contain certain mandatory provisions (to ensure e.g. interoperability or applicability) and compliance with the Recommendation is achieved when all of these mandatory provisions are met. The words "shall" or some other obligatory language such as "must" and the negative equivalents are used to express requirements. The use of such words does not suggest that compliance with the Recommendation is required of any party.

## INTELLECTUAL PROPERTY RIGHTS

ITU draws attention to the possibility that the practice or implementation of this Recommendation may involve the use of a claimed Intellectual Property Right. ITU takes no position concerning the evidence, validity or applicability of claimed Intellectual Property Rights, whether asserted by ITU members or others outside of the Recommendation development process.

As of the date of approval of this Recommendation, ITU had not received notice of intellectual property, protected by patents, which may be required to implement this Recommendation. However, implementors are cautioned that this may not represent the latest information and are therefore strongly urged to consult the TSB patent database.

© ITU 2003

All rights reserved. No part of this publication may be reproduced, by any means whatsoever, without the prior written permission of ITU.

## CONTENTS

	<b>Page</b>
1 Introduction .....	1
2 References.....	1
3 Echo control in telecommunication networks .....	2
3.1 Echo control devices.....	2
3.2 General echo control considerations from a PSTN perspective.....	4
3.3 Additional echo control considerations from the perspective of interconnected networks (e.g., private networks, the Internet) .....	4
3.4 Application-related echo control considerations.....	4
3.5 Voiceband data modem constraints.....	4
4 Application rules and operational constraints.....	5
4.1 Public network transmission planning.....	5
4.2 Delay considerations .....	5
4.3 Provisioning of the echo path capacity and echo path characteristics.....	6
4.4 Echo canceller transmission planning for multiple interconnected networks (e.g., public, private, Internet) .....	6
5 Network and service evolutionary considerations.....	6
5.1 Bit transparency of echo cancellers.....	6
5.2 Non-linearities and time variant effects in the echo path .....	7
5.3 Low bit-rate coding between tandem cancellers .....	7
5.4 Tandeming of Echo Cancellers .....	7
5.5 Convergence speed.....	9
5.6 Acoustic echo control and environments .....	10
5.7 New circuit-switched service .....	10
5.8 Comfort noise .....	11
6 Special CME networking considerations.....	11
6.1 Detailed interaction .....	12
6.2 Possible solutions .....	12
Appendix I – Echo path dispersion time.....	14
I.1 Echo-path characteristics from measurements in North America.....	14
Appendix II – Multiple Tail Circuits .....	15
II.1 Multiple tails in a typical bridged telephone call (North America).....	15



# ITU-T Recommendation G.108.2

## Transmission planning aspects of echo cancellers

### 1 Introduction

Echo cancellers are adaptive signal processors used to control echo<sup>1</sup>. Echo cancellers are present on nearly every long-distance connection and may today and in future be required on an increasing number of shorter connections which gather delay from sources other than propagation (e.g., coding, signal processing, packetization). Unintended tandem operation of echo cancellers also is an issue which needs increasing consideration. The purpose of this Recommendation is to:

- provide guidance on the general principles of operation of echo cancellers;
- identify application rules and constraints under which echo cancellers operate properly;
- provide guidance on the different tasks of transmission planners regarding the control of echo.

The user of this Recommendation is advised on the availability of ITU-T Rec. G.161 [4], "Interaction Aspects of Signal Processing Network Equipment", parts of which cover issues which are also dealt with here.

### 2 References

The following ITU-T Recommendations and other references contain provisions which, through reference in this text, constitute provisions of this Recommendation. At the time of publication, the editions indicated were valid. All Recommendations and other references are subject to revision; users of this Recommendation are therefore encouraged to investigate the possibility of applying the most recent edition of the Recommendations and other references listed below. A list of the currently valid ITU-T Recommendations is regularly published. The reference to a document within this Recommendation does not give it, as a stand-alone document, the status of a Recommendation.

- [1] ITU-T Recommendation G.100 (2001), *Definitions used in Recommendations on general characteristics of international telephone connections and circuits.*
- [2] ITU-T Recommendation G.122 (1993), *Influence of national systems on stability and talker echo in international connections.*
- [3] ITU-T Recommendation G.131 (1996), *Control of talker echo.*
- [4] ITU-T Recommendation G.161 (2002), *Interaction aspects of signal processing network equipment.*
- [5] ITU-T Recommendation G.164 (1988), *Echo suppressors.*
- [6] ITU-T Recommendation G.165 (1993), *Echo cancellers.*
- [7] ITU-T Recommendation G.168 (2002), *Digital network echo cancellers.*
- [8] ITU-T Recommendation G.961 (1993), *Digital transmission system on metallic local lines for ISDN basic rate access.*
- [9] ITU-T Recommendation P.300 (2001), *Transmission performance of group audio terminals (GATs).*
- [10] ITU-T Recommendation P.310 (2003), *Transmission characteristics for telephone-band (300-3400 Hz) digital telephones.*

---

<sup>1</sup> Echo cancellers have – in modern telecommunication networks – replaced echo suppressors.

- [11] ITU-T Recommendation P.340 (2000), *Transmission characteristics and speech quality parameters of hands-free telephones.*
- [12] ITU-T Recommendation P.341 (1998), *Transmission characteristics for wideband (150-7000 Hz) digital hands-free telephony terminals.*
- [13] ITU-T Recommendation P.342 (2000), *Transmission characteristics for telephone band (300-3400 Hz) digital loudspeaking and hands-free telephony terminals.*
- [14] ITU-T Recommendation P.561 (2002), *In-service non-intrusive measurement device – Voice service measurements.*
- [15] ITU-T Recommendation V.32 (1993), *A family of 2-wire, duplex modems operating at data signalling rates of up to 9600 bit/s for use on the general switched telephone network and on leased telephone-type circuits.*
- [16] ITU-T Recommendation V.34 (1998), *A modem operating at data signalling rates of up to 33 600 bit/s for use on the general switched telephone network and on leased point-to-point 2-wire telephone-type circuits.*

### **3 Echo control in telecommunication networks**

In the light of liberalization, responsibility of the PSTN transmission planner for the totality of the national section of the worldwide telecommunication plant can no longer be assumed. Therefore, shared responsibilities have to be implemented.

Whereas each and every transmission planner of every and each single telecommunications network may deploy echo cancellers for intra-network connections adequately, the taking into account of inter-network connections immediately will bring one or more assumptions into the equation. Such assumptions may be based on either of the following:

- enforced national or regional transmission plans (where appropriate);
- historically embedded knowledge about the network interconnected to;
- service level agreements (SLAs);
- in-service non-intrusive measurements (e.g., according to ITU-T Rec. P.561 [14]);
- information provided by means of signalling;
- experience.

#### **3.1 Echo control devices**

Whereas formerly echo suppressors [5] were in use to control echo on long-haul connections, nowadays only echo canceller are recommended. Different combinations of G.164 [5], G.165 [6] and G.168 [7] tone disablers may be found. The following combinations are possible:

- G.164 [5] echo suppressor with G.164 [5] tone disabler;
- G.165 [6] echo canceller with G.164 [5] or G.165 [6] tone disabler;
- G.168 [7] echo canceller with G.164 [5], G.165 [6] or G.168 [7] tone disabler.

NOTE – Echo suppressors are no longer recommended by the ITU-T. Nevertheless they may still be in operation in some places.

While for the purpose of transmission planning the term "echo canceller" is usually to be understood as referring to digital network echo cancellers for speech signals according to ITU-T Rec. G.168 [7] or ITU-T Rec. G.165 [6], devices compliant with ITU-T Rec. G.168 [7] are to be preferred.

Acoustical echo cancellers according to ITU-T Rec. P.340 [11] may be considered as part of the terminal and thus are subject to transmission planning in exceptional cases, only.



Echo cancelling devices for digital data transmission circuits (e.g., full duplex echo canceller modem V.32 [15], xDSL, ISDN) are also not considered for transmission planning; further information in this regard is to be found, e.g., in ITU-T Rec. G.961 [8].

### 3.1.1 Principles of operation

A voice operated device placed in the 4-wire portion of a circuit and used for reducing the cancelled end echo present on the send path by subtracting an estimation of that echo from the cancelled end echo.

Those reflections are referred to as talker echo; for detailed guidance on these parameters see ITU-T Rec. G.131 [3].

The echo canceller typically consists of various components: The key component is an adaptive filter which simulates the echo path. The algorithm which has to control the adaptive filter may be realized with different approaches, which results in a variety of different (proprietary) algorithms, having each their individual benefits and drawbacks. In addition, a non-linear processor is found in all echo cancellers which suppresses the residual echo that cannot be cancelled by the filter itself.

It is the art of the echo canceller designer:

- to optimize the complete echo canceller for the various conversational situations, including single-talk and double-talk;
- to optimize the filter adaptation for proper insertion of the NLP;
- to optimize the echo canceller for voiceband data modem and fax transmission and other operations.

Since echo cancellers may be tuned specifically to different applications, no uniform and standardized echo canceller algorithm is found.

ITU-T Rec. G.168 [7] describes minimum requirements for the performance of echo cancellers. However, for the purpose of commercial negotiations, increased and additional requirements may be applied.

### 3.1.2 Deployment in the network

Echo cancellers are deployed in the 4-wire portion of a circuit or of a circuitry. Echo cancellers may operate on a single circuit or on a multiplexed facility; in addition they may be provided as a shared resource which could be dimensioned according to traffic engineering considerations.

Amongst others, echo cancellers are providing the following functions:

- cancellation of echo signals which have passed a linear echo path;
- refraining from cancelling upon reception of an in-band disabling signal;
- return to operation after having being disabled when the total in-band signal power level drops below a specified level for a specified period of time. This design allows some networks to transport voiceband data on the same channels as speech. It also allows the echo canceller to return to operation in case it has been disabled during a speech call by error; this effect may be caused if speech segments which have spectral properties similar to the disabling signal and is referred to as "talkoff".

Echo cancellers are characterized by the interface which may either be analogue or digital, and by the subtraction mechanism for the echo which may be provided either by analogue or by digital means.

While some older echo canceller equipment may still be in use, which disables by a pure 2100-Hz tone, formerly specified in ITU-T Rec. G.164 [5] for echo suppressors, state-of-the-art echo cancellers can be disabled by means of a 2100-Hz tone with periodic phase reversals of  $180^\circ \pm 25^\circ$  as specified in ITU-T Recs G.165 [6] and G.168 [7].

### **3.2 General echo control considerations from a PSTN perspective**

Traditionally, the PSTN access line is a 2-wire analogue facility between customer premises and the switch, while the transmission facilities between the switches are typically 4-wire analogue or digital. At the 4-wire-to-2-wire conversion point (the hybrid) a perfect impedance match cannot be achieved and thus a return signal, referred to as echo, results. Therefore, one of the major concerns of the PSTN transmission planners is to ensure adequate echo control in order to eliminate impacts on end-to-end speech transmission performance due to echo effects.

For low-delay connections, echo may be controlled by the insertion of appropriate transmission path losses. Longer delay connections need echo control devices. It is the transmission planners' task to design the network such that the echo control devices provide adequate control of the echo from the 4-wire-to-2-wire conversions in the PSTN, and to ensure that the customer obtains satisfactory transmission performance.

### **3.3 Additional echo control considerations from the perspective of interconnected networks (e.g., private networks, the Internet)**

Additionally, it is the responsibility of the transmission planner of an interconnected network to ensure that terminals and interconnected network sections are designed to operate in a fashion compatible with the PSTN-based network echo cancellers (which are assumed to be in accordance with ITU-T Rec. G.168 [7] or ITU-T Rec. G.165 [6]). For example:

- Digital telephone sets do not generate echo via an electrical path per se. Network echo cancellers are not specifically designed to cancel acoustic echoes; therefore, digital sets are expected to control their own echo incurred via acoustic paths, see ITU-T Recs G.122 [2], G.131 [3], P.340 [11] and P.310 [10].
- Terminals and interconnected networks should either be designed to provide circuit extensions compatible with the PSTN (i.e., provide linear and time-invariant echo paths) or provide additional echo cancellation devices.
- Either the delay of the terminal or interconnected network should be within the operational limits of the PSTN-based echo canceller, or the terminal or interconnected network should control its own echo.

### **3.4 Application-related echo control considerations**

It is important that the modem manufacturers and application designers understand the characteristics of the PSTN-based echo cancellers and decide whether these echo cancellers should be enabled or disabled. If the modem manufacturers and application designers decide that the PSTN-based echo canceller functionality should be disabled, they should ensure that the terminal uses the appropriate methods to disable these cancellers.

### **3.5 Voiceband data modem constraints**

It is generally accepted that network echo cancellers should be disabled for voiceband data modems with integrated echo cancellers (e.g., V.32 [15], V.34 [16]), because an active network echo canceller operating in conjunction with the integral echo canceller in the modem may cause unwanted phenomena.

It was therefore decided that the obligation for making the decision to disable the network canceller should rest with the terminal, the interconnected network or with the application designed for the user and a unique technique to disable echo suppressors and echo cancellers was necessary.

Manufacturers of modems with integrated echo cancellers have designed their modems to disable network-based echo cancellers using the disabling tone specified in ITU-T Rec. G.165 [6].

Modem-integrated echo cancellers accommodate three types of echoes simultaneously:

- 1) near-end echo;
- 2) far-end echo; and
- 3) any echo generated between the near-end and the far-end.

Because the range of echo path capacities needed for each case varies widely, three echo cancellers may be necessary.

## 4 Application rules and operational constraints

### 4.1 Public network transmission planning

The evolving digital PSTN requires a loss plan to ensure that appropriate transmission levels exist at the various A/D conversion points. With such a plan, pulse code modulation (PCM) overload distortion is avoided and signal levels allow the echo canceller to operate as per its design intent.

Guidance with respect to transmission levels can be found in the G.100 series of Recommendations, whereas ITU-T Rec. P.310 [10] provides guidance for terminal design.

### 4.2 Delay considerations

As previously mentioned, conversion from the 4-wire network transmission facilities to 2-wire loop plant facilities are made on all long connections. On these connections, it is the impedance mismatch at the hybrid that causes reflections of the incident signal at the 4-wire interface to occur (see Figure 2/G.168 [7] as the reference model of the echo canceller). Because loops vary in composition, e.g., their length varies and they may be loaded or unloaded, a perfect balance cannot be obtained. Mean values of ERL vary amongst regions of the world and in some cases can be as low as 11 dB, depending on the design of analog subscriber lines and associated devices that provide 2-to-4 wire conversion (hybrids). It is the transmission planners' responsibility to determine the applicable ERL value and at which point, i.e., for which delay threshold, a network echo control device will be implemented. Guidance on the inter-relation between delay and echo return loss is to be found in ITU-T Rec. G.131 [3].

NOTE – If an appropriate transmission plan is not implemented, echo may still occur in a circuit equipped with echo cancellers.

#### 4.2.1 Echo Return Loss

In the following, the term NEST/DTDT is used to refer to the near-end speech threshold (NEST) or double talk detection threshold (DTDT). NEST/DTDT is the level at which the echo canceller detects the presence of near-end speech, i.e., the occurrence of double talk, and stops its adaptation process. In other words, double talk is detected if:

$$LR_{out} - LS_{in} \leq \text{NEST/DTDT}$$

For example, if the NEST/DTDT of an echo canceller is provisioned for 6 dB, the echo canceller detects near-end speech and stops its adaptation process if  $LR_{out} - LS_{in} \leq 6$  dB.

It is important that the NEST/DTDT value be adjusted such that the  $ERL > \text{NEST/DTDT}$ . For example, if the echo canceller is adjusted for  $\text{NEST/DTDT} = 6$  dB, the echo canceller works properly with a 4-wire circuit path where the  $ERL > 7$  dB (this includes a 1-dB safety margin). However, if the hybrid has  $ERL \leq 6$  dB, the echo canceller assumes that the echo at the  $S_{in}$  is a near-end speech. Because there is no adaptation during double talk, this will result in the presence of echo on the  $S_{out}$  path.

### 4.3 Provisioning of the echo path capacity and echo path characteristics

The link from the canceller to the hybrid is often referred to as the "echo path of the circuit". The delay of the echo to be cancelled is determined by specifying the "echo path capacity" of the canceller. To specify this echo path capacity correctly, it should be remembered that some of the received power at port  $R_{out}$  is reflected by the hybrid and multiple reflections respectively resulting in echo at port  $S_{in}$ . The time it takes the signal at  $R_{out}$  to travel from the echo canceller to the hybrid and back to the echo canceller at port  $S_{in}$  should not exceed the provisioned echo path capacity; otherwise the echo cancellation process can not work properly. This time calculation should allow for the following contributing factors:

- round-trip propagation time via the transmission media;
- delay introduced by all intermediate equipment for both directions of transmission; and
- the dispersion time due to the transmission characteristics of the circuit.

This dispersion increases the effective duration of the impulse response of the circuit that should be taken care of by the echo canceller (see Appendix I for measurement results in this regard). Note that the echo path may also still include more than one source of echo, e.g., additional hybrids. Many network configurations exist in which multiple 2-wire to 4-wire conversions are present in the echo path of an echo canceller. An example for this is given in Appendix II.

It is the transmission planners' responsibility to ensure that echo cancellers are implemented in such a way that their echo path capacity is not exceeded, so that echo cancellation can work properly. Co-operation among the transmission planners of the PSTN, of interconnected networks and of application designers is therefore required.

An echo canceller should be able to synthesize a replica of the echo path impulse response. Many echo cancellers model the echo path using a sampled data representation. Such an echo canceller, to function properly, should have sufficient storage capacity for the required number of samples (in standard applications the maximum echo path delay will determine the required storage capacity). It should be recognized that an echo canceller introduces an additional parallel echo path. If the impulse response of the echo path model differs significantly from the echo path impulse response, the total returned echo may be larger than the one caused by the echo path itself, i.e., instead of achieving echo cancellation, additional unwanted echo will be caused.

### 4.4 Echo canceller transmission planning for multiple interconnected networks (e.g., public, private, Internet)

If, in a given configuration, impairments beside echo are significant, then the analysis of the E-Model Rating R and the partial results for the impairment factors  $I_s$ ,  $I_d$  and  $I_e$ , should be the primary consideration. For values of E-Model Rating  $R \geq 80$ , a sufficient good quality can be expected: i.e., the use of echo cancellers is not necessary. For lower values of E-Model Rating R, a partial result of the E-Model calculations, the impairment factor  $I_d$  should be considered. If this impairment factor is in a range of  $I_d \geq 20$ , then the insertion of echo cancellers should be further investigated because this will likely result in a quality improvement. As a general rule, the insertion of echo cancellers should be considered during transmission planning, if values of E-Model Rating  $R \leq 80$  are obtained from calculation and talker echo is the main impairment.

## 5 Network and service evolutionary considerations

### 5.1 Bit transparency of echo cancellers

ITU-T Rec. G.165 [6] was amended in 1993 to make it clear that a 2100-Hz disabling tone with phase reversals should cause the echo canceller to disable and provide an analogue clear-channel signal path. In other words, a tone between 300 Hz and 3400 Hz should pass with its power level and frequency unaltered through the echo canceller, but 64-kbit/s bit-transparency is not guaranteed

(see 3.3/G.165 [6], 1993 revision). It is noted that 64-kbit/s transparency is achievable and is implemented in some echo cancellers, but to remain in that state, the in-band power level should remain above a predefined power level.

If cancellers are to be applied to trunks and disabled by use of a "switch to echo canceller signalling channel", the canceller should support a 64-kbit/s clear channel capability, if such capability is to be provided.

## 5.2 Non-linearities and time variant effects in the echo path

Two issues are related to the introduction of non-linear and time variant signal processing techniques in the PSTN, namely the occurrence of low bit-rate coders in the echo path, and the occurrence of digital loss or gain pads.

With the increased use of low bit-rate coders in the PSTN and in the interconnected networks, the occurrence of a low bit-rate coders in the echo path becomes more likely. Measurements carried out with echo cancellers including an ADPCM circuit in the echo path have shown that the deterioration of the residual echo level may exceed 8 dB.

The increased use of digital padding typically occurs in PSTN End-Offices when they act as a host to a digital remote line modules as well as in customer premises equipment (CPE), such as private branch exchanges (PBXs). Digital pads may add non-linearities to the circuit, thus degrading the canceller performance. The need to maintain linearity in digitally padded signals should be recognized.

The effect of low bit-rate coding techniques on non-linearity and on how this is affecting echo canceller performance is for further study.

## 5.3 Low bit-rate coding between tandem cancellers

The use of low bit-rate coders as part of the speech transmission path could also affect connections that use tandem cancellers. Figure 1 shows a circuit in which tandem cancellers are in place, and low bit-rate coders are in use between the two cancellers. Although the canceller closer to the hybrid would not be affected, the canceller on the network side would see a non-linear or a time variant echo path. The performance of the tandem still may be acceptable if the canceller closer to the network remains stable and maintains a return loss enhancement. Theoretically, the canceller on the network side would not see an echo because the canceller on the distant end has removed it. However it is recommended that the cancellers on the network side should be removed effectively from the connection.

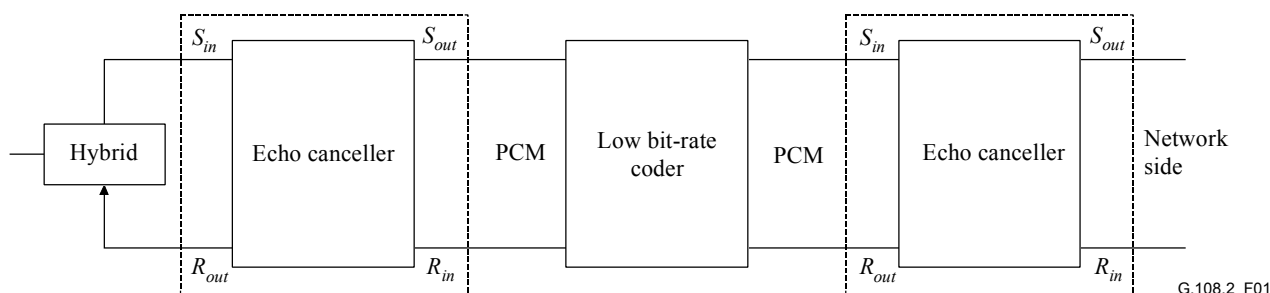

Figure 1/G.108.2 – Low bit-rate coder between tandem cancellers

## 5.4 Tandeming of Echo Cancellers

With the increasing use of dynamic routing and special features such as call forwarding, and due to the long delay introduced by low bit-rate coders, it is very likely that for some connections echo canceller tandeming cannot be avoided.

NOTE – See also 5.2.3/G.161 [4].

It is generally accepted that properly designed echo cancellers can be operated in tandem without significant echo performance degradation. Care should be taken that no artifacts like artificial echoes are produced by the echo canceller which is not facing any echo source in its tail path.

Therefore, it is required that the transmission planners ensure that echo cancellers that cause undue performance degradation when tandemed are not allowed to operate in a tandem mode. A proper method how to achieve this is for further study.

Test results showed that improper design of some of the auxiliary circuits, such as NLPs, could cause problems when the echo path delay for one of the echo cancellers in tandem exceeds its echo path capacity. For example, in some echo cancellers, the NLP may operate at inappropriate times during double talk. This occurs when the hangover time in the NLP circuit does not match the echo path delay characteristics.

To illustrate this, assume that the NLP algorithm is designed to operate on the basis of the NEST/DTDT value. In the case where the echo path delay capacity of an echo canceller is exceeded, the echo arrives later than the "expected" time. As a result, the comparison is in effect between power levels of a later far-end speech burst and an unrelated near-end speech burst. Based on this scenario, clipping can occur. For reasons like these, it is very important that transmission planners ensure that the echo path capacity of the echo canceller are never exceeded.

It has been observed that an echo canceller converging too fast may produce annoying side effects in situations where the echo path capacity is exceeded. Therefore, the echo path capacity of an echo canceller should be 4 to 6 ms larger than the expected maximum network delay. This takes into account the effect of dispersion. For example, to take into account a maximum pure delay of 44 ms, a 48-ms canceller should be selected.

Figure 2 shows an end-to-end connection scenario with three concatenated networks including their respective echo cancellers, delay values and telephony terminals.

The sample configuration in Figure 2 can be extended easily if more pairs of ECs are required.

By selectively disabling ECs (either singly or in pairs), and varying the delays, it possible to capture the relevant attributes of telephone connections with ECs.

Figure 2a provides an example for a connection via three concatenated network including a cellular network at the right end termination. In this case, EC<sub>6</sub> is not available.

Figure 2b provides an example for a connection via three concatenated network including a private network at the left end termination. In this case, EC<sub>2</sub> may not be available.

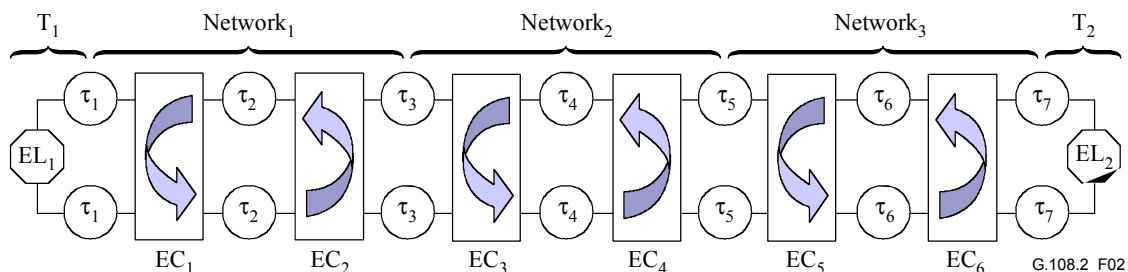

**Figure 2/G.108.2 – Reference connection for tandem ECs**

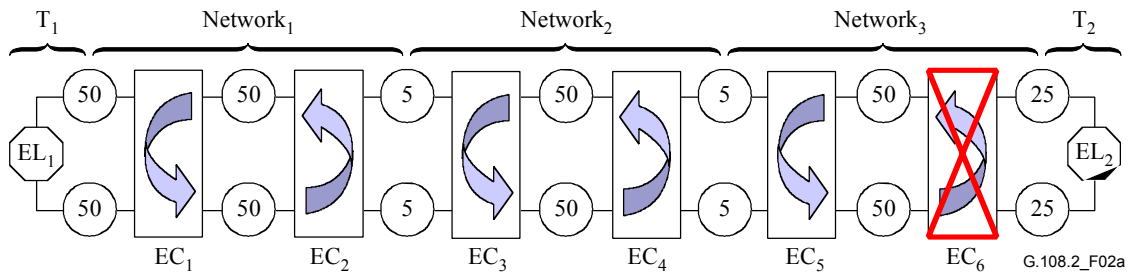

**Figure 2a/G.108.2 – Example of connection via three concatenated networks including a cellular network**

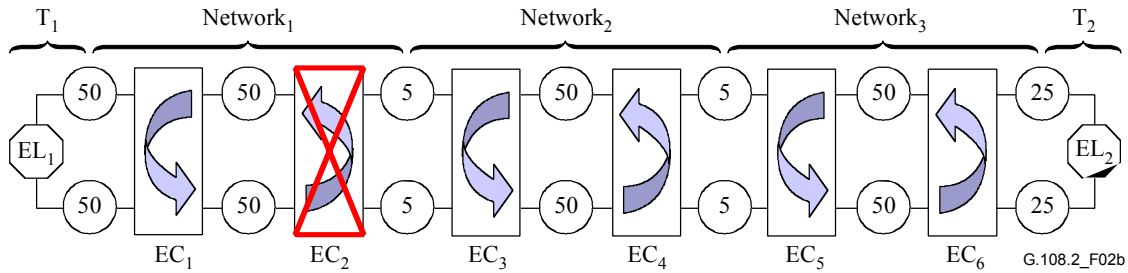
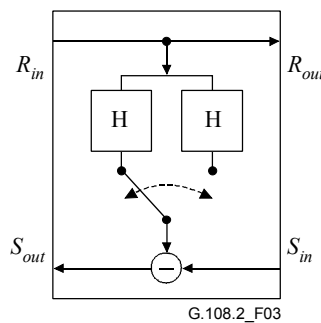

**Figure 2b/G.108.2 – Example of connection via three concatenated networks including a private network**

### 5.5 Convergence speed

High speed of convergence is desirable to reduce echo during initial acquisition, and to minimize echo when the echo path is changing. Some echo cancellers generate unwanted noise in trying to continuously adapt to the echo path. This may be related to adaptation speed. The effect is very noticeable and annoying, especially during double talk, if the adaptation process is not suspended. For some echo canceller implementations, as the speed of adaptation is increased beyond the optimum speed, the accuracy of the transfer function after adaptation becomes poorer. High speed of convergence is desirable for initial acquisition, while lower convergence may be a possible solution for subsequent tracking, since the echo transfer function changes very slowly. The need of high convergence speed when time-varying components are in the echo path is for further study.

An alternate possibility to avoid the aforementioned problems with convergence speed is that there could be two independent echo path estimators in the implementation of the echo canceller, like Figure 3 shows. One of the H registers is currently attenuating the echo while the other one calculates a better estimation of the echo path. When finding a better solution, the H register changes to it. Thus, the speed of the convergence process is not affecting the speech path directly.



**Figure 3/G.108.2 – Possible implementation of echo canceller with two independent H echo path estimators**

## 5.6 Acoustic echo control and environments

Acoustic echo control is becoming an important issue due to the increasing number of hands-free telephone sets in use. Although there is some commonality between issues encountered for acoustic echo cancellation and network echo cancellation, there are also many differences. The issues of level points, natural echo path loss (or gain), degree of loss-switching, as well as level and/or type of singing (howling) protection are all important to a study of acoustic echo cancellers. In addition, it is important that an acoustic echo canceller is capable of working in harmony with a network-based electric echo canceller.

Hands-free telephones that are connected to a 2-wire network interface which allow real double talk may produce an acoustic echo signal. This echo signal is added to the electrical echo signal coming from the 4-wire/2-wire connection of the hybrid termination and cannot be reduced sufficiently if it is de-correlated. Analogue hands-free telephones including dynamic compression devices may amplify the ambient room noise during speech pauses and transfer it to the network echo canceller input in the send path. Due to the signal-dependent switching of hands-free telephones, the level of a double talk signal may be reduced at the network echo canceller input in the send path. This may lead to increased clipping by the non-linear processor because the level of this double talk signal may fall below the threshold level.

### 5.6.1 Related ITU-T Recommendations for terminals

The ITU-T has published several Recommendations on hands-free telephones:

- ITU-T Rec. P.300 [9], Group Audio Terminal;
- ITU-T Rec. P.340 [11], Transmission characteristics of hands-free telephones;
- ITU-T Rec. P.341 [12], Transmission characteristics for wideband (150-7000 Hz) digital hands-free telephony terminals;
- ITU-T Rec. P.342 [13], Transmission characteristics for telephone band (300-3400 Hz) digital loudspeaking and hands-free telephony terminals.

Each Recommendation was developed with the understanding that the terminal is responsible for controlling its own acoustic echo.

These Recommendations present limits for different parameters like switching characteristics, Terminal Coupling Loss.

NOTE – Considering the possibility given by the network echo canceller to reduce the acoustic echo due to terminal equipment, it must be noted that the processing window should be at least 500 ms in order to take care of the typical room impulse response.

## 5.7 New circuit-switched service

It has been suggested that there may be merit in modifying the disabling mode of G.165 [6]/G.168 [7] cancellers so that upon the receipt of the disabling tone, the canceller disables until the connection is released.

It has been suggested that a customary procedure in some networks for initiating a digital transmission through a PCM-only digital speech network is to precede the digital transmission with a 2100-Hz tone to disable any echo cancellers/suppressors in the circuit. However, the cancellers remain disabled only as long as the transmitted digital data, when interpreted as PCM samples, contain sufficient energy to maintain the cancellers in the disabled state. The success of this non-standard approach depends upon the content of the digital data stream, and, as the maintenance of a sufficient power level cannot be guaranteed, proprietary means are usually used to ensure that the cancellers remain disabled. When the disabling signal is digitally generated, additional complexity is required for terminals that use a bit-level protocol and a serial interface, due to the inability of the terminal to establish octet alignment with the octets used in the transmission channel.



In this context, the need for an in-band, non-octet aligned echo canceller disable signal is for further study.

## 5.8 Comfort noise

As the telephone network migrates to more digital connections, it becomes more likely that the echo path will be analogue while the long-distance connections path will be digital. One consequence is that the long-distance path has a low idle channel noise while the echo path has a higher idle channel noise. This in turn leads to a situation called "noise modulation". When the NLP operates, the talker "hears" the idle channel noise of the digital long-distance path, but when the NLP releases, the talker "hears" the idle channel noise of the echo path and the far-end environmental noise. Thus, the talker hears intervals of speech with background noise followed by intervals of silence, which can be very annoying in some instances.

There are two known approaches for comfort noise. The first solution is to insert pseudo-random noise during the silent interval. The second solution is to allow some of the background or idle channel noise to pass through the NLP.

- Artifacts due to comfort noise insertions should be minimized.
- The inserted noise used should match the background noise, both in frequency content and level.
- Appropriate measurements of the psophometrically weighted noise level and adjustments should be done.
- The time course of changes in the level of the inserted noise should match, as closely as possible, the level changes that are occurring in the background noise.

## 6 Special CME networking considerations

It is well known that echo control is necessary on long-delay circuits, such as on satellite links. In addition, echo control may be needed, even for a short terrestrial circuit, because of the additional buffering delay in a CME. If echo is present, it may be classified as speech and reduce the compression gain.

One possible interaction relates to the potential loading effect of the comfort noise injected by the echo canceller on a CME (see Figure 4a). The operation of the echo canceller may modulate the near-end analogue noise injected into the  $S_{in}$  port of the echo canceller. This could cause the adaptive speech detector of the CME to falsely classify this change in noise level as the presence of speech. In this case, the CME transmits the noise spurt as if it were speech and thus increases the activity factor of the circuit. The consequence is a decrease in the compression gain, and in some systems, an increase in the occurrence of freeze-out.

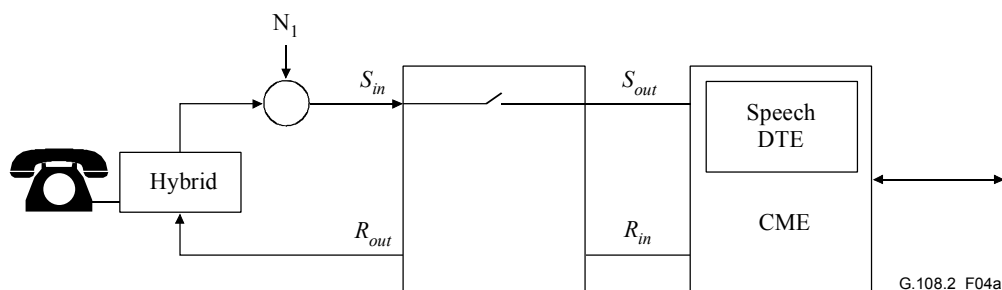

Figure 4a/G.108.2 – Speech detector/echo control device interaction

## 6.1 Detailed interaction

This interaction occurs as follows:

Received speech arrives at the receive input ( $R_{in}$ ) port of the echo control unit.

- 1) The echo suppression switch or canceller NLP activates, stopping the echo or residual echo and attenuating the near-end-generated analogue terrestrial noise ( $N_1$ ) present at the send input ( $S_{in}$ ) port.
- 2) If very little noise is generated between the echo control send output ( $S_{out}$ ) port and the CME speech detector input, the speech detector threshold adapts to its minimum level (typically,  $-50$  dBm0).
- 3) When the receive speech stops, after a suitable echo control unit hangover time, the echo suppression switch or canceller NLP closes and the near-end-generated terrestrial noise ( $N_1$ ), as seen by the CME speech detector, reappears as a step change in noise level.
- 4) The step change in noise level may exceed the speech detector threshold, causing the CME to transmit a noise spurt as if it were speech. The noise spurt duration is a function of the adaptation speed of the speech detector and the near-end-generated terrestrial noise level.

This sequence is repeated for every speech spurt and produces a very annoying speech-correlated noise spurt heard by the far-end talkers every time they stop speaking.

This interaction is not limited to single echo control device network configurations. Figure 4b shows a typical network configuration, with multiple echo control devices interacting with a CME speech detector. In this configuration, the CME speech detector may respond to unit step increases in noise power, which result from echo suppressor switch or echo canceller center clipper activations in the send paths of echo control devices 1 and 3. (The role of the center clipper is to remove the residual echoes due to imperfect cancellation.) The CME speech detector first experiences a unit step increase in noise power from echo control device 3 switch activation, followed by a second step increase from echo control device 1 switch activation. The extent to which the CME speech detector incorrectly responds to these step increases in noise power is a function of the noise power levels  $N_1$ ,  $N_2$ ,  $N_3$ , and  $N_4$  and the specific CME speech detector threshold adaptation algorithm. For example, the dual step increases in noise presented to the CME speech detector, which result from switch or center clipper activation at locations 1 and 3, are masked if the power level  $N_4$  is excessively high. Likewise, high noise power levels at  $N_2$  or  $N_3$  may mask step increases in noise power caused by echo control unit 1.

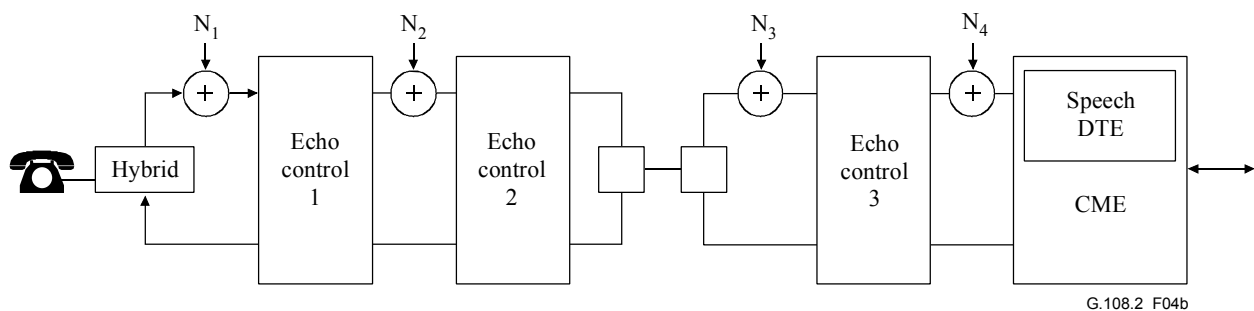

Figure 4b/G.108.2 – Multiple echo control devices in a CME network configuration

## 6.2 Possible solutions

There are several methods for dealing with the interactions between the echo control devices and the CME speech detector. In one approach, the echo control device could be modified to monitor the terrestrial-generated noise at the send-input port. When the send transmission path is broken, noise at the proper level is injected into the send-output toward the CME, keeping the noise seen by

the speech detector at a constant level (comfort noise) and avoiding speech detector activation. Not all echo cancellers may implement this approach, due to the number of different echo control devices in use and the uniqueness of this application.

In a second approach, the speech detector adaptive threshold of the CME is frozen in the presence of speech on the corresponding receive channel.

A third approach is to specify an adaptive speech detector with a fast adaptation feature, which would track step changes in noise level and minimize the noise spurts.

The approaches described above may be unacceptable due to the number of different echo control devices in use and the uniqueness of the proposed application. Further, the large base of cancellers prevents consideration of a fast phasing in of new echo cancellers.

This subject requires further study and may result in changes to ITU-T Recs G.165 [6] and/or G.168 [7] for new generation echo cancellers. The main point of this clause is that the solution depends on the speech detection procedures of both the CME and the echo canceller.

# Appendix I

## Echo path dispersion time

### I.1 Echo-path characteristics from measurements in North America

During the period from June 1998 to April 1999, a series of long-distance calls was made from Montreal to the following Provinces and States across North America: Arizona, British Columbia, California, Louisiana, Manitoba, Massachusetts, Michigan, Minnesota, Missouri, Nevada, New York, North Carolina, Ontario, Quebec, Saskatchewan, Texas and Wisconsin. The send-out and returned signals were recorded in each call and the echo-path impulse responses were calculated. This appendix reports the dispersion time values of the echo-path from the above measurements.

Figure I.1 is the histogram of the echo-path dispersion time. The largest percentage of dispersion time was between 5 and 7 ms. Only two calls had dispersion time between 11 and 12 ms. There was no call with dispersion time over 12 ms.

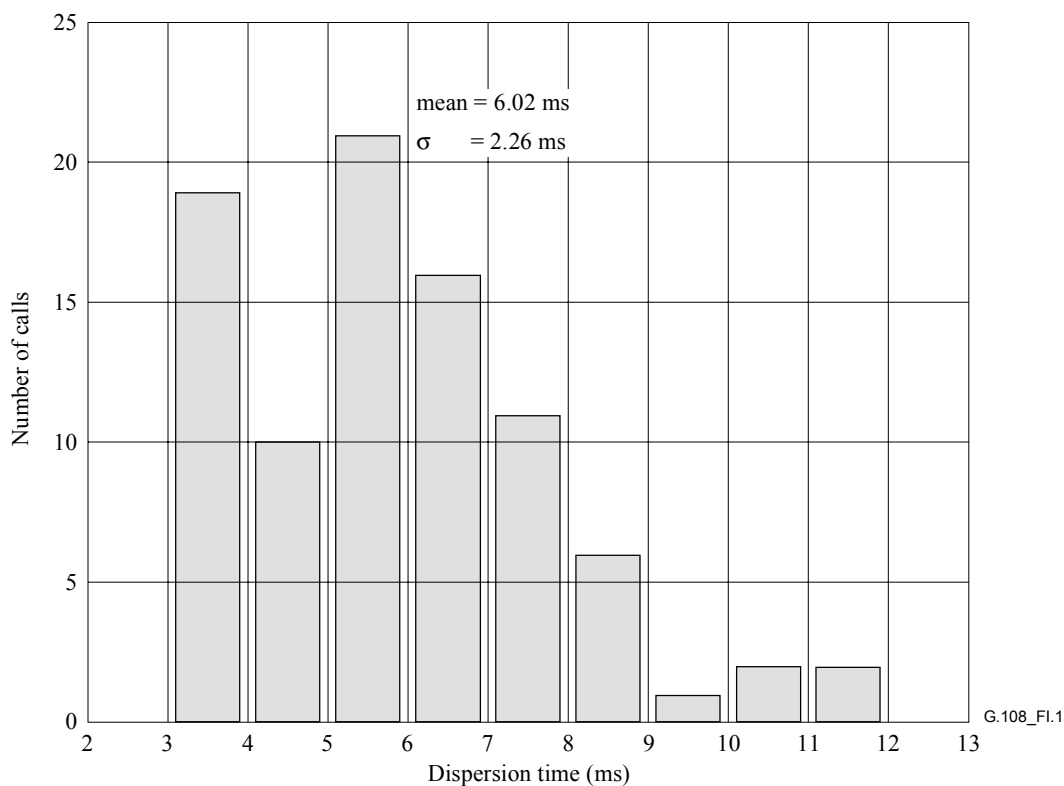

Figure I.1/G.108.2 – Histogram of dispersion time for long-distance calls

## Appendix II

### Multiple Tail Circuits

#### II.1 Multiple tails in a typical bridged telephone call (North America)

In modern networks, it may be the case that a two-party call is modified after the call is initially set up, so that one or more additional parties can participate in the conversation, as illustrated in Figure II.1.

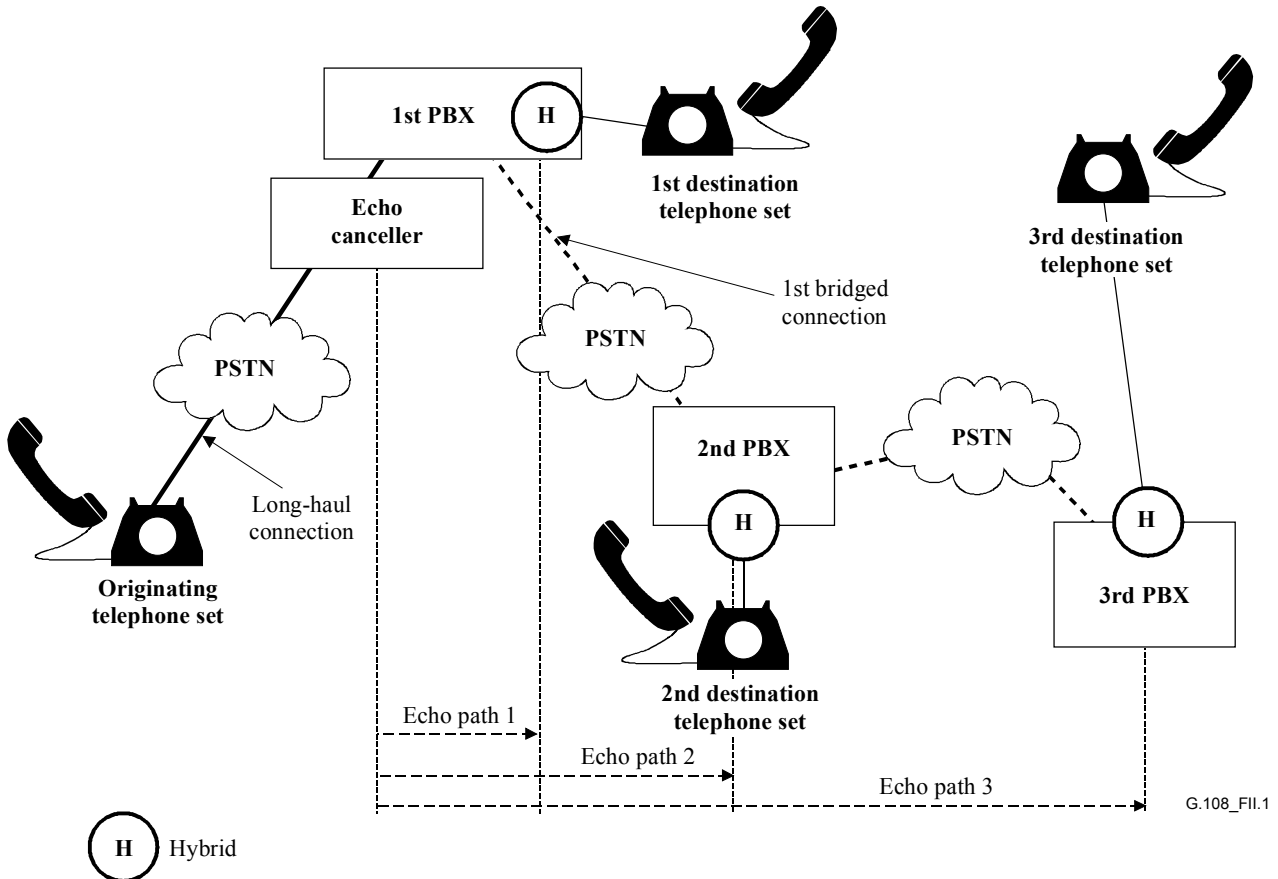

Figure II.1/G.108.2 – Multiple tails in a typical bridged telephone call

In Figure II.1, the originating telephone set initiates a call to the 1st destination set. The echo canceller sees the hybrid associated with the 1st PBX, illustrated as echo path 1. The recipient at the 1st PBX then bridges in a 2nd destination set by using the bridging function found on all modern PBXs. The echo canceller now sees the second hybrid, appended to the first, and delayed in time by the network delay between PBX 1 and 2. This is illustrated as echo path 2. The second destination may well bridge in a third destination, adding another hybrid tail associated with the hybrid in the 3rd PBX, and delayed by the sum of the network delay between PBX 1 and 2, and PBX 2 and 3. This is illustrated as echo path 3.

PBXs may not have any echo cancellation built into them, even though they perform this bridging function. This requires that the network echo canceller be able to support multiple tails up to the echo tail capacity of the canceller.





## SERIES OF ITU-T RECOMMENDATIONS

Series A	Organization of the work of ITU-T
Series B	Means of expression: definitions, symbols, classification
Series C	General telecommunication statistics
Series D	General tariff principles
Series E	Overall network operation, telephone service, service operation and human factors
Series F	Non-telephone telecommunication services
<b>Series G</b>	<b>Transmission systems and media, digital systems and networks</b>
Series H	Audiovisual and multimedia systems
Series I	Integrated services digital network
Series J	Cable networks and transmission of television, sound programme and other multimedia signals
Series K	Protection against interference
Series L	Construction, installation and protection of cables and other elements of outside plant
Series M	TMN and network maintenance: international transmission systems, telephone circuits, telegraphy, facsimile and leased circuits
Series N	Maintenance: international sound programme and television transmission circuits
Series O	Specifications of measuring equipment
Series P	Telephone transmission quality, telephone installations, local line networks
Series Q	Switching and signalling
Series R	Telegraph transmission
Series S	Telegraph services terminal equipment
Series T	Terminals for telematic services
Series U	Telegraph switching
Series V	Data communication over the telephone network
Series X	Data networks and open system communications
Series Y	Global information infrastructure and Internet protocol aspects
Series Z	Languages and general software aspects for telecommunication systems