



INTERNATIONAL TELECOMMUNICATION UNION

ITU-T

TELECOMMUNICATION
STANDARDIZATION SECTOR
OF ITU

G.122

(03/93)

TRANSMISSION SYSTEMS AND MEDIA

**GENERAL CHARACTERISTICS OF NATIONAL
SYSTEMS FORMING PART OF
INTERNATIONAL CONNECTIONS**

**INFLUENCE OF NATIONAL SYSTEMS
ON STABILITY AND TALKER ECHO
IN INTERNATIONAL CONNECTIONS**

ITU-T Recommendation G.122

(Previously "CCITT Recommendation")

FOREWORD

The ITU Telecommunication Standardization Sector (ITU-T) is a permanent organ of the International Telecommunication Union. The ITU-T is responsible for studying technical, operating and tariff questions and issuing Recommendations on them with a view to standardizing telecommunications on a worldwide basis.

The World Telecommunication Standardization Conference (WTSC), which meets every four years, established the topics for study by the ITU-T Study Groups which, in their turn, produce Recommendations on these topics.

ITU-T Recommendation G.122 was revised by the ITU-T Study Group XII (1988-1993) and was approved by the WTSC (Helsinki, March 1-12, 1993).

NOTES

1 As a consequence of a reform process within the International Telecommunication Union (ITU), the CCITT ceased to exist as of 28 February 1993. In its place, the ITU Telecommunication Standardization Sector (ITU-T) was created as of 1 March 1993. Similarly, in this reform process, the CCIR and the IFRB have been replaced by the Radiocommunication Sector.

In order not to delay publication of this Recommendation, no change has been made in the text to references containing the acronyms "CCITT, CCIR or IFRB" or their associated entities such as Plenary Assembly, Secretariat, etc. Future editions of this Recommendation will contain the proper terminology related to the new ITU structure.

2 In this Recommendation, the expression "Administration" is used for conciseness to indicate both a telecommunication administration and a recognized operating agency.

CONTENTS

	<i>Page</i>
1 Introduction	1
2 Loss (<i>a-b</i>) to avoid instability during set-up, clear-down and changes in a connection	2
3 Unweighted loss (<i>a-b</i>) on established connections	3
4 Echo loss (<i>a-b</i>) on established connections.....	3
Annex A – Measurement of stability loss (<i>a-b</i>) and echo loss (<i>a-b</i>).....	4
Annex B – Explanation of terms associated with the path <i>a-t-b</i>	6
B.1 Return loss	6
B.2 Balance return loss.....	6
B.3 Transmission loss of the path <i>a-t-b</i>	7
B.4 Stability and echo losses	9
B.5 Overall loudness rating of the echo path (talker echo loudness rating, TELR)	10
B.6 Summary of useful terms	11
References	11

INFLUENCE OF NATIONAL SYSTEMS ON STABILITY AND TALKER ECHO IN INTERNATIONAL CONNECTIONS

(Geneva, 1964; amended at Mar del Plata, 1968; Geneva, 1972, 1976 and 1980; Malaga-Torremolinos, 1984; Melbourne, 1988 and Helsinki, 1993)

1 Introduction

The information provided in this Recommendation applies to all national systems.

Representations of a national system which extend up to the virtual analogue switching points are shown in Figure 1.

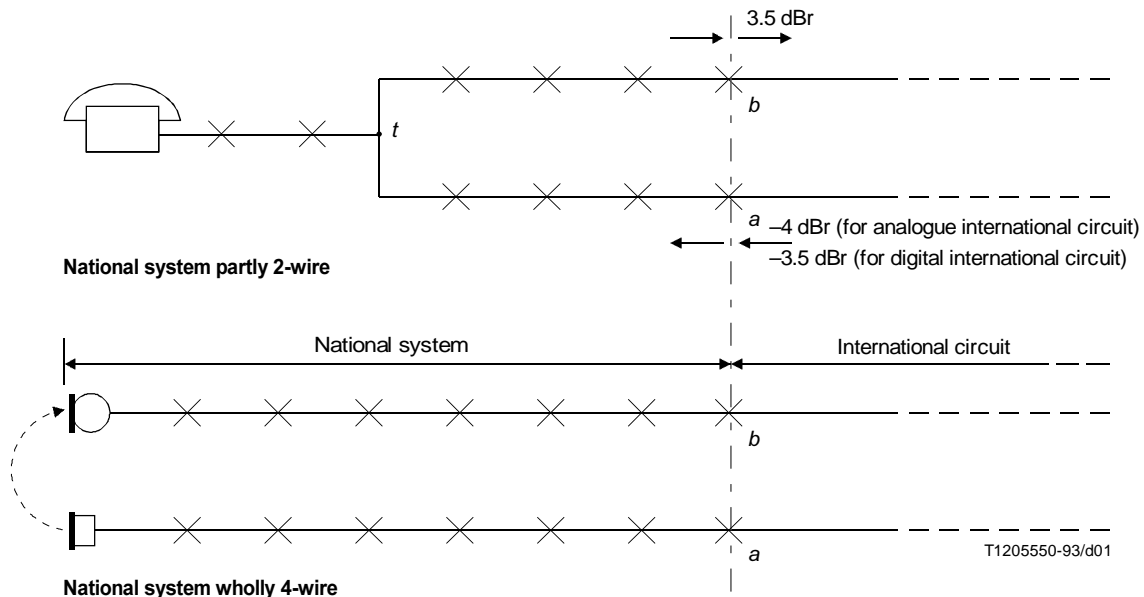

NOTE – *a, b* are the virtual analogue switching points of the international circuit.

FIGURE 1/G.122

National system representation and virtual analogue switching point definition

The transmission loss introduced between *a* and *b* by the national system, referred to as the loss (*a-b*), is important from three points of view:

- a) it contributes to the margin that the international connection has against oscillation during the setting-up and clearing-down of the connection. A minimum loss over the band 0-4 kHz is the characteristic value;
- b) it contributes to the margin of stability during a communication. Again, a minimum loss in the band 0-4 kHz is the characteristic value, but in this case the subscribers' apparatus (telephone, modem, etc.) are assumed to be connected and in the operating condition;
- c) it contributes to the control of echoes and, in respect of the subjective effect of talker echo, a weighted sum of the loss (*a-b*) over the band 300-3400 Hz is the characteristic value.

In addition, echoes circulating in any of the 4-wire loops in the national system or in the international 4-wire chain, give rise to listener echo, which can affect voice-band analogue data transmission.

The requirements stated in this Recommendation represent network performance objectives.

2 Loss (*a-b*) to avoid instability during set-up, clear-down and changes in a connection

2.1 Instability should be avoided during all normal conditions of set-up, clear-down and other changes in the composition (e.g. call-transfer) of a complete connection. To ensure adequate stability of international connections, the distribution (taken over many actual calls) of the loss (*a-b*) during the worst situation should be such that the risk of a loss (*a-b*) of 0 dB or less does not exceed 6 in 1000 calls when using the calculation method applied in 2.2. This requirement should be observed at any frequency in the band 0 to 4 kHz.

NOTES

1 The signalling and switching systems have an influence on the loss (*a-b*) under set-up and clear-down conditions. For example, in some systems 4-wire registers control the set-up and do not establish the 4-wire path until the answer signal is successfully received. In others, circuits are released immediately if busy conditions are encountered. In these circumstances the risk of oscillation does not arise.

2 Recommendation Q.32 gives information on methods of securing an adequate loss (*a-b*) of an incoming national system before the called-subscriber answers (i.e. while ringing tone is transmitted) or if busy or number unobtainable conditions are encountered.

3 If there are no such arrangements as described in Notes 1 or 2 above then, in general, it would be safe to assume that there is no balance return loss provided by the called local telephone circuit (if 2-wire). In this case the necessary loss (*a-b*) must be provided by the transmission losses in the national system.

4 The stability of international telephone connections at frequencies outside the band of effectively transmitted frequencies (i.e. below 300 Hz and above 3400 Hz) is governed by the following transmission losses at the frequencies of interest:

- the balance return loss at the terminating units;
- the transmission losses of the terminating units;
- the transmission losses of the 4-wire circuits.

5 Conditions which only last for a few tens of milliseconds can be left out of consideration because in such a short time oscillations cannot build up to a significant level.

2.2 The limit recommended in 2.1 may be met, for instance, by imposing the following simultaneous conditions on the national network:

- 1) The sum of the nominal transmission losses in both directions of transmission *a-b* and *t-b* measured between the 2-wire input of the terminating set *t*, and one or other of the virtual switching points on the international circuit, *a* or *b* should not be less than $(4 + n)$ dB, where *n* is the number of analogue or mixed analogue-digital 4-wire circuits in the national chain.
- 2) The stability balance return loss at the terminating set *t*, should have a value not less than 2 dB for the terminal conditions encountered during normal operation.
- 3) The standard deviation of variations of transmission loss of a circuit should not exceed 1 dB (see 3/G.151).

In a calculation to verify if these values are acceptable, it may be assumed that (see [1]):

- there is no significant difference between nominal and mean value of the transmission losses of circuits;
- variations of losses for both directions of transmission of the same circuit are fully correlated;
- distributions are Gaussian.

For the loss (*a-b*), it then results:

Mean value: $2 + 4 + n = 6 + n$ dB

Standard deviation: $\sqrt{4n}$ dB

With $n = 4$ the mean value becomes 10 dB and the standard deviation 4 dB, resulting in a probability for values lower than 0 dB of $6 \cdot 10^{-3}$.

NOTE – There is no need for the two quantities $a-t$ and $t-b$ to be equal, so that differential gain can be used in the national network. This practice may be needed to meet the requirements of 2/G.121, but it implies that the transmission loss in terminal service of the 4-wire chain plus the terminating sets may be different according to the direction of transmission. The choice of the nominal value of the transmission loss $t-b$ should in all cases be made with an eye to 3/G.121 dealing with the minimum sending reference equivalent to be imposed in each national chain, to avoid any risk of overloading in the international network.

3 Unweighted loss ($a-b$) on established connections

3.1 The objective is that the risk of the loss ($a-b$) reaching low values at any frequency in the range 0-4 kHz should be as small as practicable. This requires restrictions on the distribution of values of stability loss ($a-b$) for the population of actual international calls established over the national system. Such a distribution can be characterized by a mean value and a standard deviation.

The objective will be obtained by a national system sharing a mean value of at least $(10 + n)$ dB together with a standard deviation not larger than $\sqrt{6.25 + 4n}$ dB in the band 0-4 kHz; where n is the number of analogue or mixed analogue-digital 4-wire circuits in the national chain. Other distributions are acceptable as well, as long as they yield equivalent or better results calculated according to the convention of [1].

NOTES

1 See Note in 2.2.

2 In the more conventional case of a of Figure 1, the loss ($a-b$) is calculated as the sum of circuit losses, terminating loss and stability balance return loss. In fact the loss ($a-b$) at a given frequency is the sum of the circuit losses at that frequency plus the balance return loss at the same frequency. For planning purposes, it may be assumed that the stability loss is equal to or greater than the sum of the stability balance return loss plus the sum of the circuit losses at the reference frequency. This follows from the observation that the least circuit loss typically occurs in the vicinity of the reference frequency.

3 Wholly digital circuits may be assumed to have a transmission loss with mean value and standard deviation equal to zero. Voice coders in circuits or in exchanges are expected to offer smaller variations in transmission loss than carrier circuits. For the variations in transmission loss of a coder-decoder combination, standard deviations in the order of 0.4 dB have been reported.

4 The subscriber's apparatus (telephone, modem, etc.) in the local telephone circuit are assumed to be "off hook" or equivalent, and thus providing balance return loss.

5 In practice, the distribution of stability balance return loss is distinctly skew, most of the standard deviations being provided by values above the mean. It could be unduly restrictive to assume a normal distribution.

6 The CCITT manual cited in [2] describes some of the methods proposed, and in some cases successfully applied, by Administrations to improve balance return losses.

3.2 The distribution of stability loss ($a-b$) recommended in 3.1 above could, for example, be attained if, in addition to meeting the conditions of 2.2, the mean value of the stability balance return loss at the terminating set is not less than 6 dB and the standard deviation not larger than 2.5 dB.

4 Echo loss ($a-b$) on established connections

4.1 In order to minimize the effects of echo on international connections it is recommended that the distribution of echo loss ($a-b$) for the population of actual international calls established over the national system should have a mean value of not less than $15 + n$ dB with a standard deviation not exceeding $\sqrt{9 + 4n}$, where n is the number of analogue or mixed analogue-digital 4-wire circuits in the national chain.

Other distributions are acceptable as well, as long as they yield equivalent or better results calculated according to the convention of Supplement No. 2 Recommendation G.131.

NOTES

1 Echo suppressors and cancellers according to Recommendations G.164 and G.165, typically require 6 dB of signal loss ($a-b$) for the *actual* signal converging the canceller or being controlled by the suppressor. This signal loss ($a-b$) is the ratio of incident to reflected signal power on the return path. The value of signal loss ($a-b$) will depend both upon the loss ($a-b$) frequency response and the signal spectrum. Therefore, it is desirable from a performance point of view that the stability loss ($a-b$) during an established connection should be at least 6 dB, since this will ensure proper operation for any signal (frequency spectrum) in the band 0-4 kHz.

However it may not be practical to always achieve this level of performance, especially at the higher frequencies characteristic of voice-band data signals. For speech, typically the speech signal loss ($a-b$) will be at least 6 dB if the echo loss is 6 dB. However, for voice-band data signals a higher echo loss is required to ensure a data signal loss ($a-b$) of 6 dB. For some data signals an echo loss of at least 10 dB is required. It should be noted that some modems operating half-duplex on satellite circuits equipped with echo cancellers may require proper operation of the canceller to prevent long delay echoes that exceed the receiver squelch period from causing data transmission problems.

2 See Note 2 in 3.1. In a similar manner for planning purposes it can be assumed that the echo loss is equal to or greater than the sum of the echo balance return loss and the circuit losses at the reference frequency.

3 Recommendation G.131 provides guidance on the application of echo control devices.

4.2 The echo loss ($a-b$) is derived from the integral of the power transfer characteristic $A(f)$ weighted by a negative slope of 3 dB/octave starting at 300 Hz, extending to 3400 Hz, as follows:

$$\text{Echo loss } L_e = 3.85 - 10 \log_{10} \left[\int_{300}^{3400} \frac{A(f)}{f} df \right] \text{ dB}$$

where

$$A(f) = 10^{-\frac{L_{ab}(f)}{10}} \text{ with } L_{ab} = \text{loss } (a-b)$$

NOTES

1 The above method replaces an earlier method in which the echo loss of the path $a-t-b$ was provisionally defined as the expression in transmission units of the unweighted mean of the power ratios in the band 500-2500 Hz. The new method has been found to give better agreement with subjective opinion for individual connections. However, study has shown that echo path loss distributions for large samples of actual connections calculated by the two methods have almost identical means and standard deviations. Therefore, data gathered by the older method is still considered useful in planning studies.

2 Evidence was presented which showed that a white noise signal is not necessarily optimum to measure the residual echo level after cancellation, because an echo cancellor does not converge to quite the same condition as it does with a real speech signal. It may be better to use the conventional telephone signal (see Recommendation G.227) or better still, an artificial speech signal. A good compromise is the weighted noise signal based on the principle recommended above.

3 Improved balance return losses at t can be obtained when the local exchange uses 4-wire switching and the local line is permanently associated with the 2-wire/4-wire conversion unit and its balance network (see Recommendation Q.552 for examples). When there is 2-wire switching, a compromise balance network must be used.

4 There is evidence that a 4-wire handset telephone in normal use can contribute significant acoustic echo to the communication. Hence in some circumstances (low transmission loss, long delay times) echo control devices may be needed.

4.3 An example of how the recommendation quoted in 4.1 above can be achieved would be for the mean value of the sum of the transmission losses $a-t$ and $t-b$ not to be less than $(4 + n)$ dB with a standard deviation from the mean not exceeding $2\sqrt{n}$ dB, accompanied by an echo balance return loss at the terminating set t , of not less than 11 dB with a standard deviation not exceeding 3 dB.

Annex A

Measurement of stability loss ($a-b$) and echo loss ($a-b$)

(This annex forms an integral part of this Recommendation)

The stability loss ($a-b$) and the echo loss ($a-b$) as defined in 3.1 and 4.1 respectively, may be measured by apparatus at the international centre in accordance with the principle of Figure A.1.

In respect of the echo measurement, the combined response of the send and receive filters must be such that the definition given in 4.2 of the text is effectively implemented, e.g. such that the difference between a measured echo loss and one calculated from the loss/frequency characteristic does not exceed 0.25 dB.

The allocation of the total response between send and receive is not critical and any reasonable division may be used provided that

- excessive interchannel interference is avoided in national transmission systems due to an unrestricted spectrum of the transmitted signal;
- unwanted signals that may give rise to errors, e.g. hum, circuit noise, carrier leak signals, are prevented from entering the receiver.

Appropriate arrangements (not shown) are needed for automatic or manual access to the 4-wire switches at the international centre and also to ensure that due account is taken of the transmission levels at the actual switching points.

As far as the stability measurement is concerned, if a sweep oscillator is used, attention must be paid to the risks of engendering false operation of national signalling systems.

For both measurements anomalous results may be obtained if echo suppressors are encountered in the national extension.

To measure the echo loss ($a-b$), the output of the send filter is first connected to the input of the receive filter and the appropriate level set and noted. The apparatus is then connected as in Figure A.1 and the new reading on the meter noted. The loss so indicated is the echo loss ($a-b$).

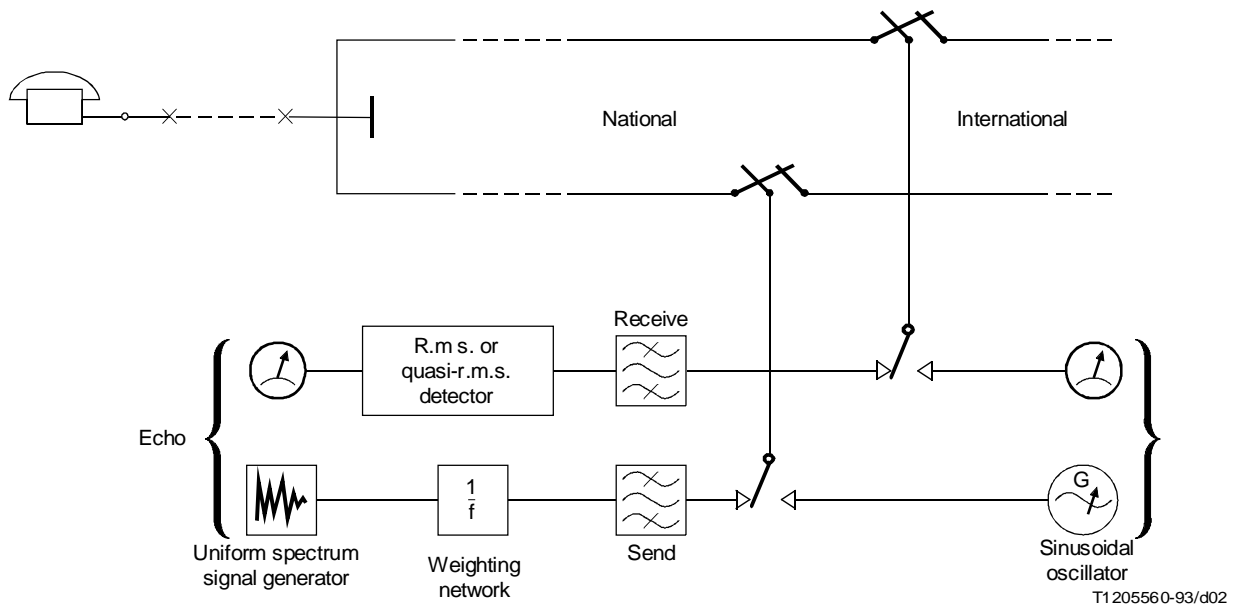

FIGURE A.1/G.122

Principle of measuring the transmission loss of the path $a-t-b$ from the points of view of stability and of echo

Annex B

Explanation of terms associated with the path *a-t-b*

(Contribution of British Telecom and Australia)

(This annex forms an integral part of this Recommendation)

B.1 Return loss

This is a quantity associated with the degree of match between two impedances and is given by the expression:

$$\text{Return loss of } Z_1 \text{ versus } Z_2 = 20 \log_{10} \left| \frac{Z_1 + Z_2}{Z_1 - Z_2} \right| \text{ dB}$$

The use of the expression “return loss” should be confined to 2-wire paths supporting signals in the two directions simultaneously.

B.2 Balance return loss

A clear definition is given in the preamble of this Recommendation. Figure B.1 illustrates the definition.

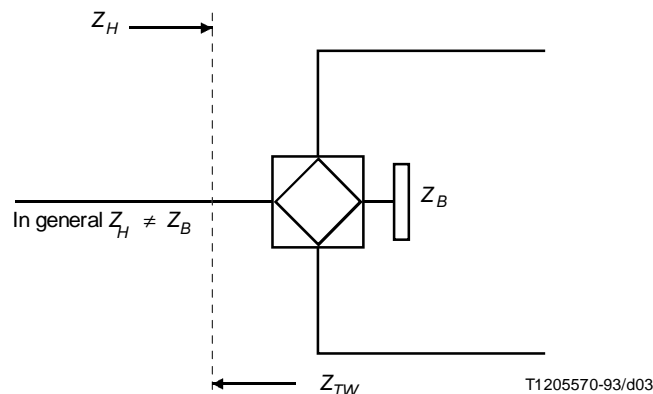

$$\text{Balance return loss} = 20 \log_{10} \left| \frac{Z_B + Z_{TW}}{Z_B - Z_{TW}} \right| \text{ dB}$$

FIGURE B.1/G.122

The 2-wire portion must be in the condition appropriate to the study, e.g. if speech echo is being studied the telephone set must be in the speaking condition.

In the particular case (which occurs very often) in which the impedances presented by each of the paths in the 4-wire portion are also Z_B (e.g. 600 ohms), then the terminating set presents an impedance of the 2-wire point which is substantially equal to Z_B . Figure B.2 illustrates this case.

The term “balance return loss” (*not* return loss) should always be used for the contribution to the loss of the path *a-t-b* attributable to the degree of match between Z_B and Z_{TW} .

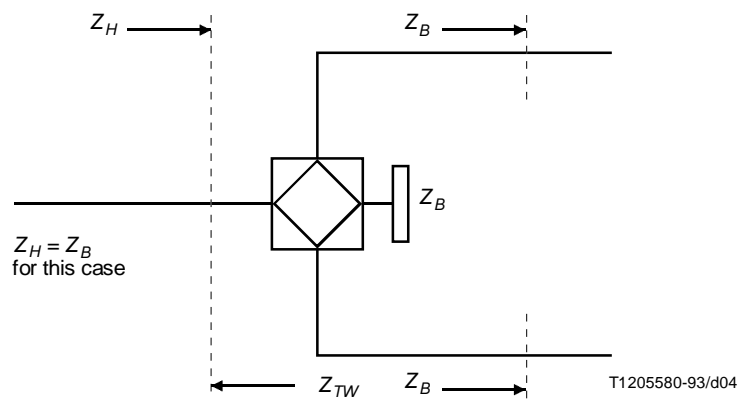

FIGURE B.2/G.122

B.3 Transmission loss of the path $a-t-b$

There is room for confusion here because the concept can be applied to arrangements in which there is no physical point "t" at all, e.g. as in some laboratory simulations of long connections in which echo is introduced by a controlled unidirectional path bridging the two 4-wire paths. The point "t" is necessary in the Recommendation because practical public switched telephone networks are being dealt with.

Thus in general two cases arise:

Case 1: There does exist a point "t" (see Figure B.3).

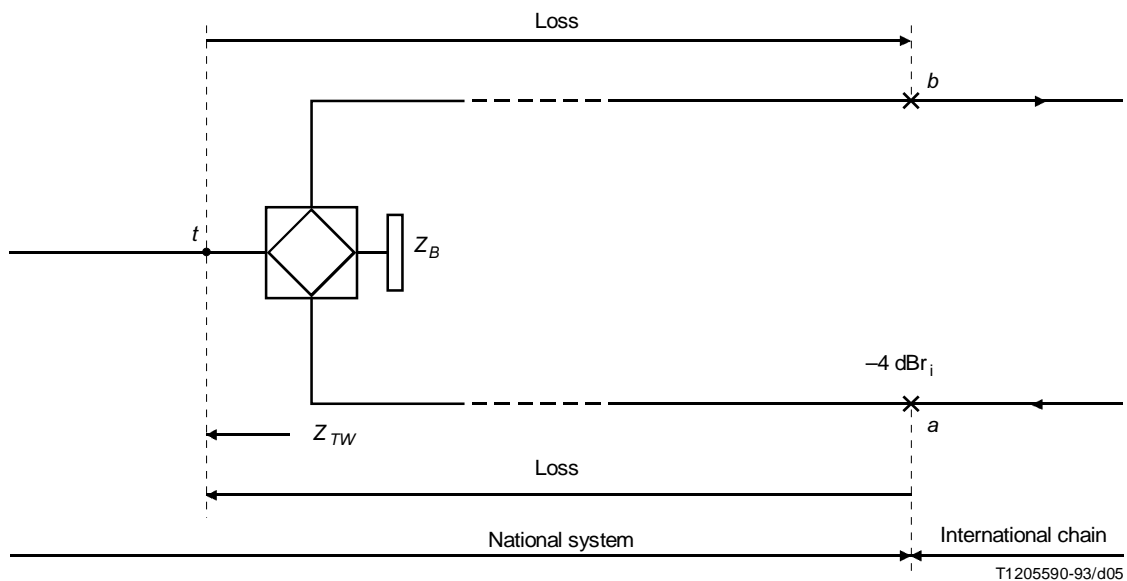

FIGURE B.3/G.122

The transmission loss of the path $a-t-b$ may be calculated from

$$\text{Loss } (a-t) + 20 \log_{10} \left| \frac{Z_B + Z_{TW}}{Z_B - Z_{TW}} \right| + \text{loss } (t-b)$$

The diagram is drawn in terms of the virtual switching points of the international circuit with their associated relative levels. The subscript i in the abbreviation dBr_i signifies that these relative levels are with respect to a 0 dBr point of the international circuit.

It is clear that any other convenient pair of relative levels (differing by 0.5 dB in the correct sense) can be used in practice, e.g. the actual switching levels used in an international centre.

Case 2: There does not exist any “ t ” (see Figure B.4).

This relates particularly to laboratory testing arrangements.

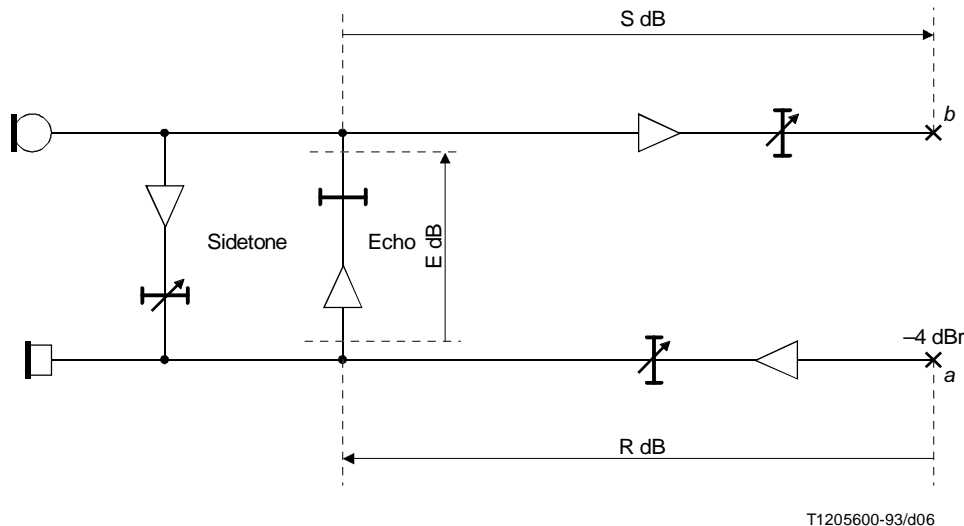

FIGURE B.4/G.122

In this case the loss of the path $a-t-b$ may be calculated from: $(R + E + S)$ dB (assuming acoustic feedback at the 4-wire telephone to be negligible).

In both cases the loss of “the path $a-t-b$ ” can in principle be directly measured by the principles described in Annex A, i.e. by injecting a signal at a and measuring the result at b , so that one may properly say for all cases

$$\left\{ \begin{array}{l} \text{transmission loss} \\ \text{of the path } a-t-b \end{array} \right\} \equiv \left\{ \begin{array}{l} \text{transmission loss} \\ \text{between } a \text{ and } b \end{array} \right\}$$

or, more shortly

$$\text{loss } (a-t-b) \equiv \text{loss } (a-b)$$

B.4 Stability and echo losses

So far the quantities dealt with are functions of frequency and yield a graph of attenuation/frequency distortion. When it is required to characterize such a graph with a single number, additional qualifying indications are, for example, stability loss ($a-b$) and echo loss ($a-b$).

The text of this Recommendation gives the definitions of these single-number descriptions thus: the stability loss ($a-b$) is the least value (measured or calculated) in the band 0-4 kHz (see 2.1 and 3.1), and the echo loss ($a-b$) is a weighted integral of the loss/frequency function over the band 300-3400 Hz, as defined in 4.2.

When the echo-path loss/frequency characteristic is available in graphical or tabular form, alternative techniques for the calculation of echo loss ($a-b$) are preferable to that suggested for the field measurement given in Annex A.

NOTE – When evaluating echo loss from graphical or tabulated data, sufficient frequency points should be taken to ensure that the influence of the shape of the amplitude/frequency characteristic is adequately preserved. The more irregular the shape, the more points should be taken for a given accuracy.

Graphical data (trapezoidal rule)

If the loss/frequency characteristic of the echo-path is available in graphical form (or the data were suitably measured) the echo loss may be calculated by using the trapezoidal rule as follows:

- 1) Divide the frequency band (300 to 3400 Hz) into N sub-bands of equal width on a log-frequency scale.
- 2) Read off the echo loss at each of the $N + 1$ frequencies at the edges of the N sub-bands, and express it as an output/input power ratio, A_i .
- 3) Calculate the echo loss using the formula:

$$L_e = -10 \log_{10} \left[\frac{1}{N} \left(\frac{A_0}{2} + A_1 + A_2 \dots + A_{N-1} + \frac{A_N}{2} \right) \right]$$

Tabulated data

When the loss/frequency data are only available at $N + 1$ discrete frequencies, which are non-uniformly spaced on a log-frequency scale, proceed as follows:

An approximation to the formula for echo loss ($a-b$) given in the text is:

$$L_e = 3.24 - 10 \log_{10} \sum_{i=1}^N (A_i + A_{i-1}) (\log_{10} f_i - \log_{10} f_{i-1})$$

where

A_0 is the output/input power ratio at frequency of $f_0 = 300$ Hz;

A_i the ratio at frequency f_i ; and

A_N the ratio at frequency $f_N = 3400$ Hz.

NOTES

1 The approximation involved is to assume that within the sub-band f_{i-1} , to f_i , the power ratio is constant and has the value $A(f) = (A_i + A_{i-1})/2$.

2 The constant 3.24 in the approximate formula arises from a combination of the constant 3.85 in the definition and other constants produced by the approximation.

The sum of product terms in the approximation formula may be conveniently calculated as illustrated in Table B.1

TABLE B.1/G.122

f_i (Hz)	$\log_{10}f_i$	$\log_{10}f_i - \log_{10}f_{i-1}$	loss (dB)	ratio A_i	$A_i + A_{i-1}$	$(3) \times (6)$
(1)	(2)	(3)	(4)	(5)	(6)	(7)
300	2.477		∞	0		
		0.222			0.124	0.0275
500	2.699		9.05	0.124		
		0.204			0.402	0.0820
800	2.903		5.56	0.278		
		0.097			0.636	0.0617
1000	3.000		4.46	0.358		
		0.176			0.838	0.1475
1500	3.176		3.19	0.48		
		0.125			0.970	0.1213
2000	3.301		3.09	0.49		
		0.097			0.881	0.0855
2500	3.398		4.08	0.391		
		0.079			0.571	0.0451
3000	3.477		7.45	0.180		
		0.055			0.180	0.0099
3400	3.532		∞	0		
Total						0.5804

$$L_e = 3.24 - 10 \log_{10} 0.5804 = 5.6 \text{ dB}$$

B.5 Overall loudness rating of the echo path (talker echo loudness rating, TELR)

Recommendation G.131 is concerned with complete talker echo paths and it is convenient to characterize this path in terms of loudness rating (LR). By convention we may regard the echo balance return loss as the contribution it makes to the overall loudness rating (OLR) of the mouth-ear echo path. Naturally, as indicated in 2, the echo loss ($a-b$), when this is already known, may be used instead of the sum of three quantities: the LR ($a-t$), the echo balance return loss at t (averaged according to 2) and the LR ($t-b$).

Hence the nominal overall loudness rating of the echo path may be calculated as illustrated in Figure B.5.

Overall loudness rating of the echo path (talker echo loudness rating, TELR) (see Annex A/G.111):

- = SLR + RLR of the talker's national system,
- + twice the LR of the international chain (i.e.: $2L_i$),
- + the echo loss ($a-b$) of the listener's national system (i.e. averaged according to this Recommendation).

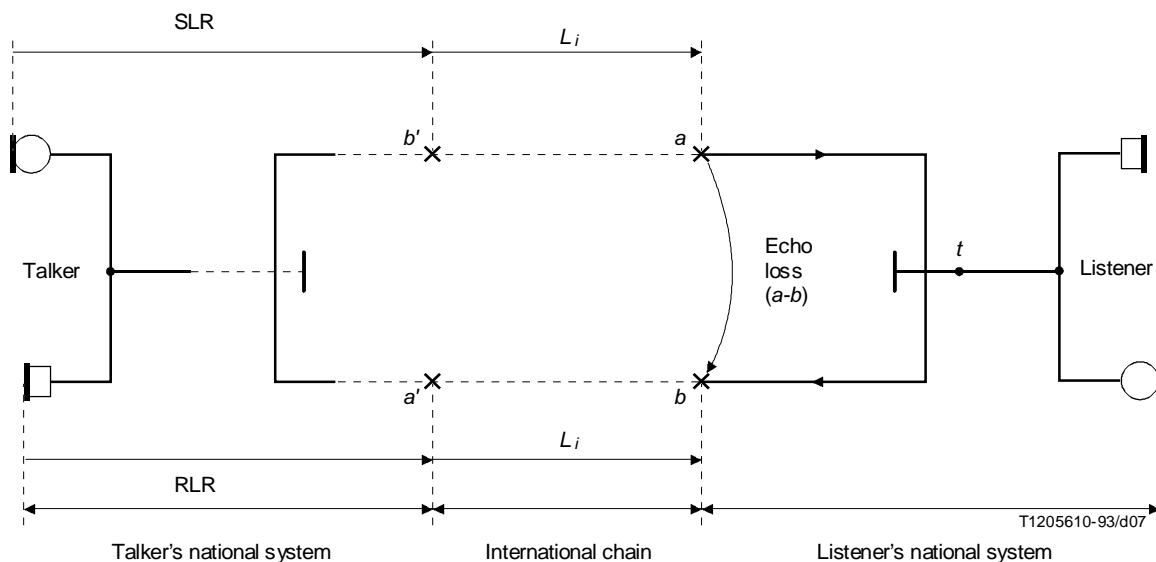

FIGURE B.5/G.122

B.6 Summary of useful terms

return loss: Relates to a 2-wire bidirectional circuit; classical definition.

balance return loss: Proportion of the loss at the $a-t-b$ path attributable to the degree of match between the 2-wire impedance and the balance impedance at the terminating unit. Applicable only if there is a point “ t ”.

transmission loss of the path $a-t-b$: Can be regarded as the loss $(a-b)$, whether there exists a physical point “ t ” or not.

stability loss $(a-b)$: The least value of the loss $(a-b)$ in the band 0 to 4 kHz.

echo loss $(a-b)$: The loss $(a-b)$ averaged according to the definition in 2 of the text.

echo balance return loss: A balance return loss averaged according to 2 of the text.

overall loudness rating of the echo path; talker echo loudness rating (TEL_R): The sum of the send loudness rating and receive loudness rating of the talker’s national system, twice the LR of the international chain, and the echo loss $(a-b)$ of the listener’s national system.

References

- [1] *Calculations of the stability of international connections established in accordance with the transmission and switching plan*, CCITT *Green Book*, Vol. III-2, Supplement No. 1, ITU, Geneva, 1973.
- [2] CCITT manual *Transmission planning of switched telephone networks*, ITU, Geneva, 1976.