



INTERNATIONAL TELECOMMUNICATION UNION

**ITU-T**

TELECOMMUNICATION  
STANDARDIZATION SECTOR  
OF ITU

**G.693**

(01/2005)

SERIES G: TRANSMISSION SYSTEMS AND MEDIA,  
DIGITAL SYSTEMS AND NETWORKS

Transmission media characteristics – Characteristics of  
optical components and subsystems

---

**Optical interfaces for intra-office systems**

ITU-T Recommendation G.693

---

ITU-T G-SERIES RECOMMENDATIONS  
**TRANSMISSION SYSTEMS AND MEDIA, DIGITAL SYSTEMS AND NETWORKS**

INTERNATIONAL TELEPHONE CONNECTIONS AND CIRCUITS	G.100–G.199
GENERAL CHARACTERISTICS COMMON TO ALL ANALOGUE CARRIER-TRANSMISSION SYSTEMS	G.200–G.299
INDIVIDUAL CHARACTERISTICS OF INTERNATIONAL CARRIER TELEPHONE SYSTEMS ON METALLIC LINES	G.300–G.399
GENERAL CHARACTERISTICS OF INTERNATIONAL CARRIER TELEPHONE SYSTEMS ON RADIO-RELAY OR SATELLITE LINKS AND INTERCONNECTION WITH METALLIC LINES	G.400–G.449
COORDINATION OF RADIOTELEPHONY AND LINE TELEPHONY	G.450–G.499
TRANSMISSION MEDIA CHARACTERISTICS	G.600–G.699
<b>Characteristics of optical components and subsystems</b>	<b>G.660–G.699</b>
DIGITAL TERMINAL EQUIPMENTS	G.700–G.799
DIGITAL SECTIONS AND DIGITAL LINE SYSTEM	G.900–G.999
QUALITY OF SERVICE AND PERFORMANCE - GENERIC AND USER-RELATED ASPECTS	G.1000–G.1999
TRANSMISSION MEDIA CHARACTERISTICS	G.6000–G.6999
DIGITAL TERMINAL EQUIPMENTS	G.7000–G.7999
DIGITAL NETWORKS	G.8000–G.8999

*For further details, please refer to the list of ITU-T Recommendations.*

# **ITU-T Recommendation G.693**

## **Optical interfaces for intra-office systems**

### **Summary**

This Recommendation provides parameters and values for optical interfaces of single channel intra-office systems of nominal 10 Gbit/s and 40 Gbit/s aggregate bit rate. Applications are specified with target distances of 0.6 and 2 km and various loss budgets for G.652, G.653 and G.655 fibres.

### **Source**

ITU-T Recommendation G.693 was approved on 13 January 2005 by ITU-T Study Group 15 (2005-2008) under the ITU-T Recommendation A.8 procedure.

## FOREWORD

The International Telecommunication Union (ITU) is the United Nations specialized agency in the field of telecommunications. The ITU Telecommunication Standardization Sector (ITU-T) is a permanent organ of ITU. ITU-T is responsible for studying technical, operating and tariff questions and issuing Recommendations on them with a view to standardizing telecommunications on a worldwide basis.

The World Telecommunication Standardization Assembly (WTSA), which meets every four years, establishes the topics for study by the ITU-T study groups which, in turn, produce Recommendations on these topics.

The approval of ITU-T Recommendations is covered by the procedure laid down in WTSA Resolution 1.

In some areas of information technology which fall within ITU-T's purview, the necessary standards are prepared on a collaborative basis with ISO and IEC.

## NOTE

In this Recommendation, the expression "Administration" is used for conciseness to indicate both a telecommunication administration and a recognized operating agency.

Compliance with this Recommendation is voluntary. However, the Recommendation may contain certain mandatory provisions (to ensure e.g. interoperability or applicability) and compliance with the Recommendation is achieved when all of these mandatory provisions are met. The words "shall" or some other obligatory language such as "must" and the negative equivalents are used to express requirements. The use of such words does not suggest that compliance with the Recommendation is required of any party.

## INTELLECTUAL PROPERTY RIGHTS

ITU draws attention to the possibility that the practice or implementation of this Recommendation may involve the use of a claimed Intellectual Property Right. ITU takes no position concerning the evidence, validity or applicability of claimed Intellectual Property Rights, whether asserted by ITU members or others outside of the Recommendation development process.

As of the date of approval of this Recommendation, ITU had not received notice of intellectual property, protected by patents, which may be required to implement this Recommendation. However, implementors are cautioned that this may not represent the latest information and are therefore strongly urged to consult the TSB patent database.

© ITU 2005

All rights reserved. No part of this publication may be reproduced, by any means whatsoever, without the prior written permission of ITU.

## CONTENTS

	<b>Page</b>
1 Scope .....	1
2 References.....	1
3 Terms and definitions .....	1
3.1 Terms defined in other Recommendations.....	1
4 Abbreviations and acronyms .....	2
5 Classification of optical interfaces.....	2
5.1 Applications.....	2
5.2 Nomenclature .....	3
6 Parameter definitions.....	6
6.1 System operating wavelength range.....	6
6.2 Transmitter .....	6
6.3 Optical path .....	8
6.4 Receiver.....	10
7 Optical parameter values .....	11
8 Optical engineering approach.....	16
Appendix I – Optical crosstalk impact.....	16
Appendix II – Examples of system configurations using applications defined in this Recommendation.....	17
Appendix III – Differences in parameter values between G.693 application codes and equivalent G.691 and G.959.1 codes.....	18



# ITU-T Recommendation G.693

## Optical interfaces for intra-office systems

### 1 Scope

The purpose of this Recommendation is to provide optical interface specifications to enable transverse (multivendor) compatibility of nominal 10 Gbit/s and 40 Gbit/s aggregate bit rate intra-office systems for link distances up to 2 km. This Recommendation defines links using optical fibres according to ITU-T Recs G.652, G.653 and G.655.

Parallel interface specifications may be included in future revisions.

### 2 References

The following ITU-T Recommendations and other references contain provisions which, through reference in this text, constitute provisions of this Recommendation. At the time of publication, the editions indicated were valid. All Recommendations and other references are subject to revision; users of this Recommendation are therefore encouraged to investigate the possibility of applying the most recent edition of the Recommendations and other references listed below. A list of the currently valid ITU-T Recommendations is regularly published. The reference to a document within this Recommendation does not give it, as a stand-alone document, the status of a Recommendation.

- ITU-T Recommendation G.652 (2003), *Characteristics of a single-mode optical fibre and cable*.
- ITU-T Recommendation G.653 (2003), *Characteristics of a dispersion-shifted single-mode optical fibre and cable*.
- ITU-T Recommendation G.655 (2003), *Characteristics of a non-zero dispersion-shifted single-mode optical fibre and cable*.
- ITU-T Recommendation G.691 (2003), *Optical interfaces for single-channel STM-64 and other SDH systems with optical amplifiers*.
- ITU-T Recommendation G.957 (1999), *Optical interfaces for equipments and systems relating to the synchronous digital hierarchy*.
- ITU-T Recommendation G.959.1 (2003), *Optical transport network physical layer interfaces*.

### 3 Terms and definitions

#### 3.1 Terms defined in other Recommendations

This Recommendation uses the following term defined in ITU-T Rec. G.709/Y.1331:

- Completely standardized OTUk (OTUk).

This Recommendation uses the following terms defined in ITU-T Rec. G.959.1:

- Optical tributary signal class NRZ 10G (NRZ 10G).
- Optical tributary signal class NRZ 40G (NRZ 40G).

## 4 Abbreviations and acronyms

This Recommendation uses the following abbreviations:

ASE	Amplified Spontaneous Emission
BER	Bit Error Ratio
DGD	Differential Group Delay
EX	Extinction ratio
ffs	For Further Study
MLM	Multi-Longitudinal Mode
MPI	Main Path Interface
MPN	Mode Partition Noise
NA	Not Applicable
NRZ	Non-Return to Zero
ORL	Optical Return Loss
PMD	Polarization Mode Dispersion
PRBS	Pseudo Random Binary Sequence
RMS	Root Mean Square
SDH	Synchronous Digital Hierarchy
SLM	Single-Longitudinal Mode
SMSR	Side Mode Suppression Ratio
VSR	Very Short Reach
WDM	Wavelength Division Multiplex

## 5 Classification of optical interfaces

### 5.1 Applications

This Recommendation defines optical interfaces for single-channel intra-office systems for link distances up to 2 km. These interface descriptions are intended to enable transverse (multivendor) compatibility. Figure 1 illustrates a system of the type considered in this Recommendation, and shows the reference points used to specify optical interface parameters.

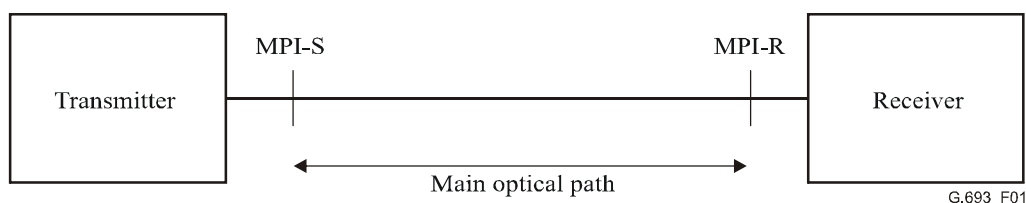

NOTE – The main optical path includes fibre and connectors, and may include other passive optical devices such as photonic cross-connects.

**Figure 1/G.693 – Optical link example showing reference points defined in this Recommendation**



Parameters are specified for the transmitter at point MPI-S, for the receiver at point MPI-R, and for the main optical path between points MPI-S and MPI-R.

Maximum values of chromatic dispersion for the G.652 fibre applications in this Recommendation are obtained from the target distance and operating wavelength range, using Figure A.2/G.957. Maximum values of chromatic dispersion for G.653 fibre applications are calculated as the product of target distance and 3.3 ps/nm·km, except for the VSR2000-2L3 application, where the value is set to equal the value for the VSR2000-2L2 application. Maximum values of chromatic dispersion for G.655 fibre applications are derived from ITU-T Rec. G.655 using the target distances of the respective applications, except for the VSR2000-2L5 application, where the value is set to equal the value for the VSR2000-2L2 application.

The main optical path for systems described in this Recommendation may include passive optical devices, e.g., photonic cross-connects, which introduce significant attenuation. Thus, values of maximum attenuation may not be inferred from the target distances of applications. In this Recommendation, attenuation categories are used to distinguish among applications which have the same source and fibre type and target distance, and are intended for the same signal class, but have different values of maximum attenuation. Four attenuation categories are defined with maximum attenuation values of 4 dB, 6 dB, 12 dB and 16 dB, respectively. A fifth category is defined (with a maximum attenuation value ffs) in case the maximum attenuation value provided by the H category is too low to cover all applications.

This Recommendation includes applications with nominal 40 Gbit/s aggregate bit rate for loss category R. It is expected that, as 40 Gbit/s technology matures, applications for loss category L will be specified in addition.

Appendix II shows examples of system configurations using applications defined in this Recommendation.

## 5.2 Nomenclature

Applications in this Recommendation are distinguished by application codes. Each code indicates the target distance, highest class of optical tributary signal supported, attenuation category and source and fibre type of the associated application.

Application codes have the following structure:

– W-yAz

where:

W indicates target distance:

– VSR600, VSR1000 and VSR2000, indicating target distances of 0.6 km, 1 km and 2 km, respectively.

y indicates highest class of optical tributary signal supported:

– 2 indicating NRZ 10G;  
– 3 indicating NRZ 40G.

A indicates attenuation category:

– R indicating maximum attenuation of 4 dB.  
– L indicating maximum attenuation of 6 dB.  
– M indicating maximum attenuation of 12 dB.  
– H indicating maximum attenuation of 16 dB.  
– V indicating maximum attenuation of ffs dB.

The V category has been introduced in case the maximum attenuation value provided by the H category is too low to cover all applications.

z indicates the source and fibre type:

- 1 indicating nominally 1310 nm sources on G.652 fibre;
- 2 indicating nominally 1550 nm sources on G.652 fibre;
- 3 indicating nominally 1550 nm sources on G.653 fibre;
- 5 indicating nominally 1550 nm sources on G.655 fibre.

Tables 1 and 2 summarize the application codes described in this Recommendation.

**Table 1/G.693 – Classification of optical interfaces with 0.6 km target distance**

<b>Target distance<sup>a)</sup></b>	<b>0.6 km</b>		
<b>Attenuation category<sup>a)</sup></b>	<b>R</b>	<b>M</b>	
Source nominal wavelength (nm)	1310	1310	1550
Type of fibre	G.652	G.652	G.652 G.653 G.655
Application codes for Optical tributary signal class NRZ 10G	VSR600-2R1	VSR600-2M1	VSR600-2M2 VSR600-2M3 VSR600-2M5
Application codes for Optical tributary signal class NRZ 40G	–	–	–
a) Target distances and attenuation categories are for classification and not for specification.			

**Table 2/G.693 – Classification of optical interfaces with 2 km target distance**

<b>Target distance<sup>a)</sup></b>	<b>2 km</b>					
<b>Attenuation category<sup>a)</sup></b>	<b>R</b>		<b>L</b>	<b>M</b>		<b>H</b>
Source nominal wavelength (nm)	1310	1550	1550	1310	1550	1550
Type of fibre	G.652	G.652 G.653 G.655	G.652 G.653 G.655	G.652	G.652 G.653 G.655	G.652 G.653 G.655
Application codes for Optical tributary signal class NRZ 10G	VSR2000-2R1	–	VSR2000-2L2 VSR2000-2L3 VSR2000-2L5	–	–	–
Application codes for Optical tributary signal class NRZ 40G	VSR2000-3R1	VSR2000-3R2 VSR2000-3R3 VSR2000-3R5		VSR2000-3M1	VSR2000-3M2 VSR2000-3M3 VSR2000-3M5	VSR2000-3H2 VSR2000-3H3 VSR2000-3H5
a) Target distances and attenuation categories are for classification and not for specification.						

## **6 Parameter definitions**

All parameter values are worst-case values, assumed to be met over the range of standard operating conditions (i.e., temperature and humidity ranges), and they include ageing effects. The parameters are specified relative to an optical section design objective of a bit error ratio (BER) not worse than  $10^{-12}$  for any combination of parameters within the ranges given in the tables for each specified system. Achieving this BER objective shall not require the application of forward error correction.

The optical line coding used for system interfaces in this Recommendation is binary non-return to zero (NRZ).

### **6.1 System operating wavelength range**

The operating wavelength range is the maximum allowable range for source wavelength. Within this range, the source wavelength can be selected for different fibre-related impairments. The receiver must have the minimum operating wavelength range that corresponds to the maximum allowable range for the source wavelength.

The operating wavelength range of fibre optic transmission systems is basically determined by the attenuation and dispersion characteristics of the various fibre and source types. A detailed discussion of these aspects can be found in ITU-T Rec. G.957.

NOTE – When a wavelength-fixed or tuneable filter to eliminate Amplified Spontaneous Emission (ASE) is used before the receiver, the operating wavelength band may be limited, and the transverse compatibility may not be guaranteed.

### **6.2 Transmitter**

#### **6.2.1 Source type**

Depending on attenuation/dispersion characteristics and hierarchical level of each application code, feasible transmitter devices include multi-longitudinal mode (MLM) lasers and single-longitudinal mode (SLM) lasers. For each of the applications, this Recommendation indicates a nominal source type. It is understood that the indication of a nominal source type in this Recommendation is not a requirement and that SLM devices can be substituted for any application showing MLM as the nominal source type without any degradation in system performance.

#### **6.2.2 Spectral characteristics**

##### **6.2.2.1 Maximum RMS width**

The maximum root mean square (RMS) width or the standard deviation  $\sigma$  (in nm) of the spectral distribution of a multi-longitudinal mode (MLM) laser considers all laser modes, which are not more than 20 dB down from the peak mode. Only a system with an MLM laser at 1310 nm requires this specification.

##### **6.2.2.2 Maximum –20 dB width**

The maximum –20 dB spectral width (in nm) of an SLM laser is specified by the maximum full width of the central wavelength peak, measured 20 dB down from the maximum amplitude of the central wavelength under standard operating conditions.

##### **6.2.2.3 Side mode suppression ratio**

The side mode suppression ratio (SMSR) is defined as the ratio of the largest peak of the total source spectrum to the second largest peak. The spectral resolution of the measurement shall be better (i.e., the optical filter bandwidth shall be less) than the maximum spectral width of the peak, as defined above. The second largest peak may be next to the main peak or far removed from it.

NOTE – Within this definition, spectral peaks that are separated from the largest peak by the clock frequency are not considered to be side modes.

The SMSR specification is intended to minimize the occurrence of BER degradations due to mode partition noise (MPN). Since MPN is a transient effect with low probability, SMSR measurements on PRBS or continuous signals may underestimate the MPN. The SMSR specification is relevant only to SLM laser sources.

### **6.2.3 Maximum mean output power**

The maximum value of the average power of a pseudo-random data sequence coupled into fibre by the transmitter.

### **6.2.4 Minimum mean output power**

The minimum value of the average power of a pseudo-random data sequence coupled into fibre by the transmitter.

### **6.2.5 Extinction ratio**

The extinction ratio (EX) is defined as:

$$EX = 10 \times \text{Log}_{10} (A/B)$$

In the above definition of EX, A is the average optical power level at the centre of a logical "1" and B is the average optical power level at the centre of a logical "0". The convention adopted for optical logic levels is:

- emission of light for a logical "1";
- no emission for a logical "0".

### **6.2.6 Eye pattern mask**

In this Recommendation, general transmitter pulse shape characteristics including rise time, fall time, pulse overshoot, pulse undershoot, and ringing, all of which should be controlled to prevent excessive degradation of the receiver sensitivity, are specified in the form of a mask of the transmitter eye diagram at point MPI-S. For the purpose of an assessment of the transmit signal, it is important to consider not only the eye opening, but also the overshoot and undershoot limitations. The parameters specifying the mask of the transmitter eye diagram are shown in Figure 2.

Acceptable transmitter eye diagrams must avoid crossing any of the hatched lines. The test arrangement is as specified for STM-64 in Annex A/G.691. Filter tolerances for the NRZ 10G optical reference receiver are as specified for STM-64 in Annex A/G.691. Filter tolerances for a NRZ 40G optical reference receiver are ffs.

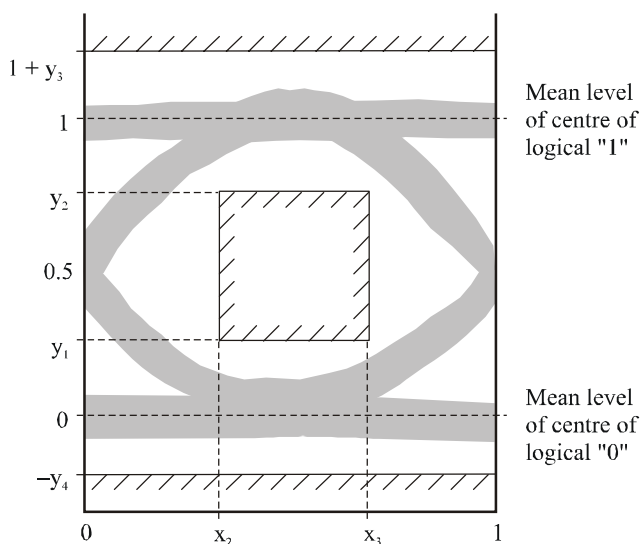

	NRZ 10G 1310 nm region	NRZ 10G 1550 nm region	NRZ 40G
$x_3 - x_2$	0.2	0.2	0.2
$y_1$	0.25	0.25	0.25
$y_2$	0.75	0.75	0.75
$y_3$	0.4	0.25	0.25
$y_4$	0.25	0.25	0.25

G.693\_F02

NOTE –  $x_2$  and  $x_3$  of the rectangular eye mask need not be equidistant with respect to the vertical axes at 0 UI and 1 UI.

**Figure 2/G.693 – Mask of the eye diagram for the optical transmit signal**

### 6.3 Optical path

To ensure system performance for each of the applications considered in Table 1, it is necessary to specify attenuation and dispersion characteristics of the optical path between points MPI-S and MPI-R.

#### 6.3.1 Maximum attenuation

The maximum path attenuation where the system in question operates under end-of-life conditions at a BER of  $10^{-12}$  (or as given by the application code), under worst-case transmit-side signal and dispersion. Attenuation specifications are assumed to be worst-case values including losses due to splices, connectors, optical attenuators (if used), other passive optical devices, e.g., photonic cross-connect, and any additional cable margin to cover allowances for degradation of any connectors, optical attenuators or other passive optical devices between points MPI-S and MPI-R, if used.

#### 6.3.2 Minimum attenuation

The minimum path attenuation that allows the system in question, operating under worst-case transmit-side conditions, to achieve a BER no worse than  $10^{-12}$  (or as given by the application code).

### 6.3.3 Dispersion

#### 6.3.3.1 Maximum chromatic dispersion

This parameter defines the maximum uncompensated absolute value of the main path chromatic dispersion that the system shall be able to tolerate. The required maximum dispersion tolerance of the systems is set to a value equal to the target distance times 20 ps/km·nm for G.652 fibre, and 3.3 ps/nm·km for G.653 fibre in the 1550 nm region, as well as for G.652 fibre and an operating wavelength range of 1290 nm to 1330 nm. The required maximum dispersion tolerance of systems with operating wavelength of 1530 nm to 1565 nm for G.655 fibre is set to a value equal to the target distance times 10 ps/km·nm. These are considered worst-case dispersion values for the relevant fibre types.

The maximum chromatic dispersion value includes contributions from fibre and all other elements present in the optical path. In the case that these passive optical devices introduce additional chromatic dispersion, the achievable link distance may be reduced. Alternatively, an application with a higher chromatic dispersion tolerance may be used to overcome this restriction.

The allowed penalty for the optical path considers all deterministic effects due to chromatic dispersion as well as the penalty due to the maximum differential group delay.

#### 6.3.3.2 Maximum differential group delay

Differential group delay (DGD) is the time difference between the fractions of a pulse that are transmitted in the two principal states of polarization of an optical signal. More information on this topic can be found in ITU-T Rec. G.691.

In this Recommendation, the maximum differential group delay is defined to be the value of DGD that the system must tolerate with a maximum sensitivity degradation of 1 dB.

### 6.3.4 Reflections

Reflections are caused by refractive index discontinuities along the optical path. If not controlled, they can degrade system performance through their disturbing effect on the operation of the optical source or amplifier, or through multiple reflections which lead to interferometric noise at the receiver. In this Recommendation, reflections from the optical path are controlled by specifying the:

- minimum optical return loss (ORL) of the cable plant at point MPI-S, including any connectors; and
- maximum discrete reflectance between points MPI-S and MPI-R.

Reflectance denotes the reflection from any single discrete reflection point, whereas the return loss is the total returned power from the entire fibre, including both discrete reflections and distributed backscattering such as Rayleigh scattering.

Measurement methods for reflections are described in Appendix I/G.957. For the purpose of reflectance and return loss measurements, points MPI-S and MPI-R are assumed to coincide with the endface of each connector plug. It is recognized that this does not include the actual reflection performance of the respective connectors in the operational system. These reflections are assumed to have the nominal value of reflection for the specific type of connectors used.

The maximum number of connectors, or other discrete reflection points which may be included in the optical path (e.g., for distribution frames, or WDM components), must be such as to allow the specified overall optical return loss to be achieved. If this cannot be done using connectors meeting the maximum discrete reflections cited in Tables 3 and 4, then connectors having better reflection performance must be employed. Alternatively, the number of connectors must be reduced. It may also be necessary to limit the number of connectors, or to use connectors having improved reflectance performance in order to avoid unacceptable impairments due to multiple reflections.

In Tables 3 and 4, the value of  $-27$  dB maximum discrete reflectance between points MPI-S and MPI-R is intended to minimize the effects of multiple reflections (e.g., interferometric noise). The value for maximum receiver reflectance is chosen to ensure acceptable penalties due to multiple reflections for all likely system configurations involving multiple connectors, etc. Systems employing fewer or higher performance connectors produce fewer multiple reflections and, consequently, are able to tolerate receivers exhibiting higher reflectance.

## **6.4 Receiver**

### **6.4.1 Sensitivity**

Receiver sensitivity is defined as the minimum value of mean received power at point MPI-R to achieve a  $1 \times 10^{-12}$  BER. This must be met with a transmitter with worst-case values of transmitter eye mask, extinction ratio, optical return loss at point MPI-S, receiver connector degradations and measurement tolerances. The definition of receiver sensitivity under worst-case conditions is further discussed in Annex A/G.691.

The receiver sensitivity does not have to be met in the presence of dispersion, optical crosstalk or reflections. These effects are specified separately in the allocation of maximum optical path penalty.

NOTE – The receiver sensitivity does not have to be met in the presence of transmitter jitter in excess of the appropriate jitter generation limit (e.g., G.8251 for OTN Optical tributary signals).

The receiver sensitivities specified in Tables 3 and 4 are worst-case, end-of-life values. Start-of-life sensitivities must be adequate to account for receiver ageing and environmental conditions.

### **6.4.2 Overload**

Receiver overload is the maximum acceptable value of the received average power at point MPI-R for a  $1 \times 10^{-12}$  BER.

### **6.4.3 Path penalty**

The path penalty is the apparent reduction of receiver sensitivity due to distortion of the signal waveform during its transmission over the path. It is manifested as a shift of the system's BER-curves towards higher input power levels. This corresponds to a positive path penalty. Negative path penalties may exist under some circumstances, but should be small. (A negative path penalty indicates that a less than perfect transmitter eye has been partially improved by the path dependent distortions.) Ideally, the BER-curves should only be translated, but shape variations are not uncommon, and may indicate the emergence of BER-floors. Since the path penalty is a change in the receiver's sensitivity, it is measured at a BER-level of  $10^{-12}$ .

A maximum path penalty of 1 dB for low-dispersion systems is allowed. The path penalties are not made proportional to the target distances to avoid operating systems with high penalties.

The average value of the random dispersion penalties due to PMD is included in the allowed path penalty. In this respect, the transmitter/receiver combination is required to tolerate an actual DGD of 0.3 bit period with a maximum sensitivity degradation of 1 dB (with 50% of optical power in each principal state of polarization). For a well-designed receiver, this corresponds to a penalty of 0.1-0.2 dB for a DGD of 0.1 bit period. The actual DGD that may be encountered in operation is a randomly varying fibre/cable property, and cannot be specified in this Recommendation. This subject is further discussed in Appendix I/G.691.

Any additional sensitivity degradation due to optical crosstalk (e.g., caused by non-ideal switching) is assumed to be small enough to be included within the path penalty value. Cases where this is not true are for further study. Optical crosstalk penalty is further discussed in Appendix I.



## 7 Optical parameter values

Optical parameter values for applications shown in Tables 1 and 2 are given in Tables 3 and 4. Systems which comply with these values should not require forward error correction in order to satisfy BER objectives. Tables 3 and 4 include columns in which more than one application code is shown in the heading. Where the row entries in these columns contain a single value, it applies to all of the application codes. Where the row contains multiple entries, the values apply to the application codes in the same order as they appear in the column heading.

For those applications which were previously specified in ITU-T Recs G.691 or G.959.1, any differences between G.693 parameter values and the values in the superseded G.691 and G.959.1 application codes are given in Appendix III.

**Table 3/G.693 – Optical interface parameters specified for applications with 0.6 km target distance**

Application code	Unit	VSR600-2R1	VSR600-2M1	VSR600-2M2 VSR600-2M3 VSR600-2M5
<b>G.691 Application code</b>		I-64.1r		
<b>G.959.1 Application code</b>		PII1-2D1r		
<b>Target distance</b>	m	600	600	600
<b>Bit rate/line coding of optical signals</b>	–	NRZ 10G	NRZ 10G	NRZ 10G
<b>Fibre type</b>	–	G.652	G.652	G.652 G.653 G.655
<b>Transmitter at reference point MPI-S</b>				
Source type		MLM	MLM	SLM
Operating wavelength range	nm	1268-1360	1268-1360	1530-1565
Maximum mean output power	dBm	–1	+5	+2
Minimum mean output power	dBm	–6	+2	–1
Spectral characteristics:				
– maximum RMS width ( $\sigma$ )	nm	3	3	NA
– maximum –20 dB width	nm	NA	NA	ffs
– minimum SMSR	dB	NA	NA	30
Minimum EX	dB	6	6	8.2

**Table 3/G.693 – Optical interface parameters specified for applications  
with 0.6 km target distance**

<b>Application code</b>	<b>Unit</b>	<b>VSR600-2R1</b>	<b>VSR600-2M1</b>	<b>VSR600-2M2 VSR600-2M3 VSR600-2M5</b>
<b>Main optical path, MPI-S to MPI-R</b>				
Maximum attenuation	dB	4	12	12
Minimum attenuation	dB	0	6 <sup>a)</sup>	3 <sup>a)</sup>
Maximum chromatic dispersion <sup>b)</sup>	ps/nm	3.8	3.8	12 for G.652 <sup>c)</sup> 2 for G.653 6 for G.655
Maximum DGD	ps	30	30	30
Min ORL of cable plant at MPI-S, including any connectors	dB	14	14	14
Maximum discrete reflectance between MPI-S and MPI-R	dB	-27	-27	-27
Polarization-dependent loss	dB	ffs	ffs	ffs
<b>Receiver at reference point MPI-R</b>				
Minimum sensitivity (BER of $1 \times 10^{-12}$ )	dBm	-11	-11	-14
Minimum overload	dBm	-1	-1	-1
Maximum optical path penalty	dB	1	1	1
Maximum reflectance of receiver, measured at MPI-R	dB	-14	-14	-14
<sup>a)</sup> This value of minimum attenuation is highly undesirable. A value of 0 dB is desired and should be sought as technology matures. <sup>b)</sup> In the case that passive optical devices in the main optical path introduce additional chromatic dispersion, the achievable link distance may be reduced. Alternatively, an application with a higher chromatic dispersion tolerance may be used to overcome this restriction. <sup>c)</sup> This application can also be used on G.653 and G.655 fibre.				

Table 4/G.693 – Optical interface parameters specified for applications with 2 km target distance

Application code	Unit	VSR2000-2R1	VSR2000-2L2 VSR2000-2L3 VSR2000-2L5	VSR2000-3R1 <sup>e)</sup>	VSR2000-3R2 <sup>f)</sup> VSR2000-3R3 <sup>e)</sup> VSR2000-3R5 <sup>e)</sup>	VSR2000-3M1	VSR2000-3M2 VSR2000-3M3 VSR2000-3M5	VSR2000-3H2 VSR2000-3H3 VSR2000-3H5
<b>G.691 Application code</b>		I-64.1	I-64.2r – –					
<b>G.959.1 Application code</b>		P111-2D1	P111-2D2r					
<b>Target distance</b>	km	2	2	2	2	2	2	2
<b>Bit rate/line coding of optical signals</b>	–	NRZ 10G	NRZ 10G	NRZ 40G	NRZ 40G	NRZ 40G	NRZ 40G	NRZ 40G
<b>Fibre type</b>	–	G.652	G.652 G.653 G.655	G.652	G.652 G.653 G.655	G.652	G.652 G.653 G.655	G.652 G.653 G.655
<b>Transmitter at reference point MPI-S</b>								
Source type		SLM	SLM	SLM	SLM	SLM	SLM	SLM
Operating wavelength range	nm	1290-1330	1530-1565	1290-1330	1530-1565	1290-1330	1530-1565	1530-1565
Maximum mean output power	dBm	–1	–1	+3	+3	+10	+3	+3
Minimum mean output power	dBm	–6	–5	0	0	+8	0	0
Spectral characteristics:								
– maximum RMS width ( $\sigma$ )	nm	NA	NA	NA	NA	NA	NA	NA
– maximum –20 dB width	nm	1	ffs	ffs	ffs	ffs	ffs	ffs
– minimum SMSR	dB	30	30	35	35	35	35	35
Minimum EX	dB	6	8.2	8.2	8.2	8.2	7	7

Table 4/G.693 – Optical interface parameters specified for applications with 2 km target distance

Application code	Unit	VSR2000-2R1	VSR2000-2L2 VSR2000-2L3 VSR2000-2L5	VSR2000-3R1 <sup>e)</sup>	VSR2000-3R2 <sup>f)</sup> VSR2000-3R3 <sup>e)</sup> VSR2000-3R5 <sup>e)</sup>	VSR2000-3M1	VSR2000-3M2 VSR2000-3M3 VSR2000-3M5	VSR2000-3H2 VSR2000-3H3 VSR2000-3H5
<b>Main optical path, MPI-S to MPI-R</b>								
Maximum attenuation	dB	4	6	4	4	12	12	16
Minimum attenuation	dB	0	0	0	0	8 <sup>a)</sup>	3 <sup>a)</sup>	3
Maximum chromatic dispersion <sup>b)</sup>	ps/nm	6.6	40	6.6	40 for G.652 <sup>c)</sup> 6.6 for G.653 20 for G.655	6.6	40 for G.652 <sup>c)</sup> 6.6 for G.653 20 for G.655	40 for G.652 <sup>c)</sup> 6.6 for G.653 20 for G.655
Maximum DGD	ps	30	30	7.5	7.5	7.5	7.5	7.5
Min ORL of cable plant at MPI-S, including any connectors	dB	14	24	24	24	24	24	24
Maximum discrete reflectance between MPI-S and MPI-R	dB	-27	-27	-27	-27	-27	-27	-27
Polarization dependent loss	dB	ffs	ffs	ffs	ffs	ffs	ffs	ffs
<b>Receiver at reference point MPI-R</b>								
Minimum sensitivity (BER of $1 \times 10^{-12}$ )	dBm	-11	-13	-5	-6 for G.652 -5 for G.653 -5 for G.655	-5	-14 for G.652 -13 for G.653 -13 for G.655	-18 for G.652 -17 for G.653 -17 for G.655
Minimum overload	dBm	-1	-1	+3	+3	+2	0	0
Maximum optical path penalty	dB	1	2	1 <sup>d)</sup>	2 <sup>d)</sup> for G.652 1 <sup>d)</sup> for G.653 1 <sup>d)</sup> for G.655	1 <sup>d)</sup>	2 <sup>d)</sup> for G.652 1 <sup>d)</sup> for G.653 1 <sup>d)</sup> for G.655	2 <sup>d)</sup> for G.652 1 <sup>d)</sup> for G.653 1 <sup>d)</sup> for G.655
Maximum reflectance of receiver, measured at MPI-R	dB	-14	-27	-27	-27	-27	-27	-27

**Table 4/G.693 – Optical interface parameters specified for applications with 2 km target distance**

- a) This value of minimum attenuation is highly undesirable. A value of 0 dB is desired and should be sought as technology matures.
- b) In the case that passive optical devices in the main optical path introduce additional chromatic dispersion, the achievable link distance may be reduced. Alternatively, an application with a higher chromatic dispersion tolerance may be used to overcome this restriction.
- c) This application can also be used on G.653 and G.655 fibre.
- d) The method used to verify this penalty is ffs.
- e) A receiver in compliance with this application is required to operate in any of the application codes VSR2000-3R1, VSR2000-3R3 or VSR2000-3R5. It shall, as a minimum, operate over the wavelength range of 1290-1330 nm as well as the range 1530-1565 nm.
- f) A receiver in compliance with application VSR2000-3R2 will operate in either of the application codes VSR2000-3R3 or VSR2000-3R5. It will also operate in the application code VSR2000-3R1 if its operating wavelength range includes 1290-1330 nm.

## 8 Optical engineering approach

For a worst-case design approach, the relationships among maximum/minimum mean output power, maximum/minimum attenuation, minimum overload, minimum sensitivity and maximum optical path penalty are shown in Figure 3/G.957.

### Appendix I

#### Optical crosstalk impact

Some of the applications in this Recommendation are intended to support the inclusion of a passive photonic cross-connect in the main optical path as depicted in Figure I.1. Photonic cross-connects may introduce non-negligible optical crosstalk due to non-ideal switching.

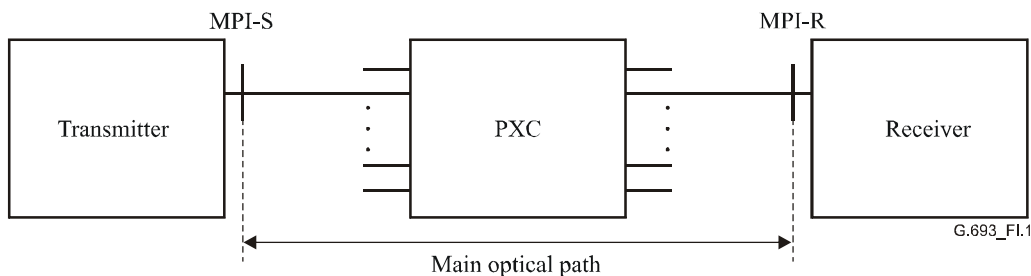

**Figure I.1/G.693 – Optical link example showing use of a passive photonic cross-connect between MPI-S and MPI-R**

Optical crosstalk is the ratio of the total disturbing power, under all specified conditions, to the power in the desired signal, at the MPI-R reference point in Figure I.1, within the optical bandwidth of the optical receiver, expressed in dB.

Optical system performance may be affected by the level of optical crosstalk in the signal arriving at the receiver. Excessive optical crosstalk at the receiver will cause the performance of the system to deteriorate by an amount defined to be the crosstalk penalty.

Further study is needed to quantify the allowable optical crosstalk penalty.

## Appendix II

### Examples of system configurations using applications defined in this Recommendation

The applications defined in this Recommendation are characterized by relatively short target distances, i.e., less than or equal to 2 km. One consequence of this characteristic is that main optical path total attenuation will, in general, be dominated by the loss contributions of connectors and passive optical devices rather than by fibre loss.

Figure II.1 shows configurations corresponding to several applications defined in this Recommendation, with different combinations of attenuation category and target distance. The figure illustrates that, in selecting an application, the choice of attenuation category is determined by the devices in the main optical path, e.g., whether or not a photonic cross-connect is present, while the choice of target distance is determined by the relative proximity of the equipments which the G.693 interface interconnects.

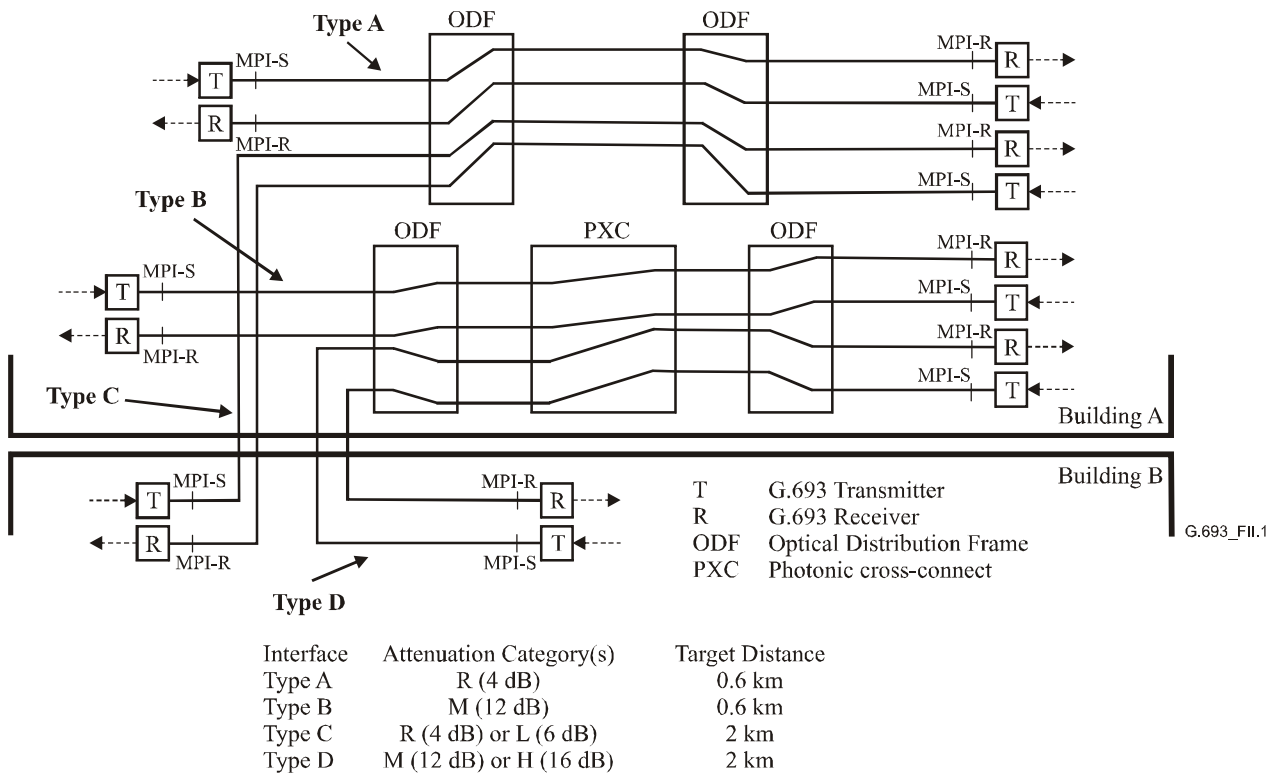

**Figure II.1/G.693 – Examples of system configurations using applications defined in this Recommendation**

## Appendix III

### Differences in parameter values between G.693 application codes and equivalent G.691 and G.959.1 codes

Several application codes in this Recommendation are equivalent to application codes which were specified in previous versions of ITU-T Recs G.691 and G.959.1. In some instances, the parameter values in G.693 differ from those in the equivalent G.691 and G.959.1 application codes, which are now superseded by G.693. Tables III.1, III.2 and III.3 below indicate all such differences between G.693 parameter values and corresponding values in the equivalent G.691 and G.959.1 application codes.

**Table III.1/G.693 – Parameter value differences between VSR600-2R1 (G.693), P1I1-2D1r (G.959.1) and I-64.1r (G.691) application codes**

Application code/ Recommendation	Unit	VSR600-2R1/ G.693	P1I1-2D1r/ G.959.1	I-64.1r/ G.691
Operating wavelength range	nm	1268-1360	1260-1360	1260-1360

**Table III.2/G.693 – Parameter value differences between VSR2000-2R1 (G.693) and P1I1-2D1 (G.959.1) application codes**

Application code/ Recommendation	Unit	VSR2000-2R1/ G.693	P1I1-2D1/ G.959.1
Maximum chromatic dispersion	ps/nm	6.6	NA

**Table III.3/G.693 – Parameter value differences between VSR2000-2L2 (G.693), P1I1-2D2r (G.959.1) and I-64.2r (G.691)**

Application code/ Recommendation	Unit	VSR2000-2L2/ G.693	P1I1-2D2r/ G.959.1	I-64.2r/ G.691
Operating wavelength range	nm	1530-1565	1500-1580	(same as G.693)
Maximum attenuation	dB	6	7	7
Minimum sensitivity	dBm	-13	-14	-14





## SERIES OF ITU-T RECOMMENDATIONS

Series A	Organization of the work of ITU-T
Series D	General tariff principles
Series E	Overall network operation, telephone service, service operation and human factors
Series F	Non-telephone telecommunication services
<b>Series G</b>	<b>Transmission systems and media, digital systems and networks</b>
Series H	Audiovisual and multimedia systems
Series I	Integrated services digital network
Series J	Cable networks and transmission of television, sound programme and other multimedia signals
Series K	Protection against interference
Series L	Construction, installation and protection of cables and other elements of outside plant
Series M	Telecommunication management, including TMN and network maintenance
Series N	Maintenance: international sound programme and television transmission circuits
Series O	Specifications of measuring equipment
Series P	Telephone transmission quality, telephone installations, local line networks
Series Q	Switching and signalling
Series R	Telegraph transmission
Series S	Telegraph services terminal equipment
Series T	Terminals for telematic services
Series U	Telegraph switching
Series V	Data communication over the telephone network
Series X	Data networks, open system communications and security
Series Y	Global information infrastructure, Internet protocol aspects and next-generation networks
Series Z	Languages and general software aspects for telecommunication systems