



INTERNATIONAL TELECOMMUNICATION UNION

ITU-T

TELECOMMUNICATION
STANDARDIZATION SECTOR
OF ITU

G.8021/Y.1341

(08/2004)

SERIES G: TRANSMISSION SYSTEMS AND MEDIA,
DIGITAL SYSTEMS AND NETWORKS

Digital networks – General aspects

SERIES Y: GLOBAL INFORMATION
INFRASTRUCTURE, INTERNET PROTOCOL ASPECTS
AND NEXT GENERATION NETWORKS

Internet protocol aspects – Transport

**Characteristics of Ethernet transport network
equipment functional blocks**

ITU-T Recommendation G.8021/Y.1341

ITU-T G-SERIES RECOMMENDATIONS
TRANSMISSION SYSTEMS AND MEDIA, DIGITAL SYSTEMS AND NETWORKS

INTERNATIONAL TELEPHONE CONNECTIONS AND CIRCUITS	G.100–G.199
GENERAL CHARACTERISTICS COMMON TO ALL ANALOGUE CARRIER-TRANSMISSION SYSTEMS	G.200–G.299
INDIVIDUAL CHARACTERISTICS OF INTERNATIONAL CARRIER TELEPHONE SYSTEMS ON METALLIC LINES	G.300–G.399
GENERAL CHARACTERISTICS OF INTERNATIONAL CARRIER TELEPHONE SYSTEMS ON RADIO-RELAY OR SATELLITE LINKS AND INTERCONNECTION WITH METALLIC LINES	G.400–G.449
COORDINATION OF RADIOTELEPHONY AND LINE TELEPHONY TESTING EQUIPMENTS	G.450–G.499
TRANSMISSION MEDIA CHARACTERISTICS	G.500–G.599
DIGITAL TERMINAL EQUIPMENTS	G.600–G.699
DIGITAL NETWORKS	G.700–G.799
DIGITAL SECTIONS AND DIGITAL LINE SYSTEM	G.800–G.899
QUALITY OF SERVICE AND PERFORMANCE – GENERIC AND USER-RELATED ASPECTS	G.900–G.999
TRANSMISSION MEDIA CHARACTERISTICS	G.1000–G.1999
DIGITAL TERMINAL EQUIPMENTS	G.6000–G.6999
DIGITAL NETWORKS	G.7000–G.7999
General aspects	G.8000–G.8099
Design objectives for digital networks	G.8100–G.8199
Quality and availability targets	G.8200–G.8299
Network capabilities and functions	G.8300–G.8399
SDH network characteristics	G.8400–G.8499
Management of transport network	G.8500–G.8599
SDH radio and satellite systems integration	G.8600–G.8699
Optical transport networks	G.8700–G.8799

For further details, please refer to the list of ITU-T Recommendations.

ITU-T Recommendation G.8021/Y.1341

Characteristics of Ethernet transport network equipment functional blocks

Summary

This Recommendation specifies both the functional components and the methodology that should be used in order to specify Ethernet transport network functionality of network elements; it does not specify individual Ethernet transport network equipment as such.

Source

ITU-T Recommendation G.8021/Y.1341 was approved on 22 August 2004 by ITU-T Study Group 15 (2001-2004) under the ITU-T Recommendation A.8 procedure.

Keywords

Atomic functions, equipment functional blocks, Ethernet transport network.

FOREWORD

The International Telecommunication Union (ITU) is the United Nations specialized agency in the field of telecommunications. The ITU Telecommunication Standardization Sector (ITU-T) is a permanent organ of ITU. ITU-T is responsible for studying technical, operating and tariff questions and issuing Recommendations on them with a view to standardizing telecommunications on a worldwide basis.

The World Telecommunication Standardization Assembly (WTSA), which meets every four years, establishes the topics for study by the ITU-T study groups which, in turn, produce Recommendations on these topics.

The approval of ITU-T Recommendations is covered by the procedure laid down in WTSA Resolution 1.

In some areas of information technology which fall within ITU-T's purview, the necessary standards are prepared on a collaborative basis with ISO and IEC.

NOTE

In this Recommendation, the expression "Administration" is used for conciseness to indicate both a telecommunication administration and a recognized operating agency.

Compliance with this Recommendation is voluntary. However, the Recommendation may contain certain mandatory provisions (to ensure e.g. interoperability or applicability) and compliance with the Recommendation is achieved when all of these mandatory provisions are met. The words "shall" or some other obligatory language such as "must" and the negative equivalents are used to express requirements. The use of such words does not suggest that compliance with the Recommendation is required of any party.

INTELLECTUAL PROPERTY RIGHTS

ITU draws attention to the possibility that the practice or implementation of this Recommendation may involve the use of a claimed Intellectual Property Right. ITU takes no position concerning the evidence, validity or applicability of claimed Intellectual Property Rights, whether asserted by ITU members or others outside of the Recommendation development process.

As of the date of approval of this Recommendation, ITU had not received notice of intellectual property, protected by patents, which may be required to implement this Recommendation. However, implementors are cautioned that this may not represent the latest information and are therefore strongly urged to consult the TSB patent database.

© ITU 2005

All rights reserved. No part of this publication may be reproduced, by any means whatsoever, without the prior written permission of ITU.

CONTENTS

	Page
1	Scope 1
2	References..... 3
3	Terms and definitions 4
4	Acronyms and abbreviations 6
5	Methodology..... 9
6	Supervision 9
6.1	Defects..... 9
6.2	Consequent actions 9
6.3	Defect correlations..... 9
6.4	Performance filters 9
7	Information flow across reference points 9
8	Generic processes 10
8.1	Mux/Demux process..... 10
8.2	Queuing process 11
8.3	Filter process 11
8.4	Replicate process 12
8.5	802.3 protocols processes..... 12
8.6	MAC FCS generation 15
8.7	MAC frame check 15
8.8	Link quality supervision 15
8.9	FDI/BDI generation and detection 15
9	Ethernet MAC layer (ETH) functions 15
9.1	ETH flow forwarding functions 15
9.2	ETH flow termination functions (ETH_FT)..... 16
9.3	Ethernet/client adaptation functions 16
9.4	Traffic conditioning function (ETH_TC)..... 16
9.5	ETH segment sub-layer functions 16
10	Ethernet PHY layer (ETYn) functions 16
10.1	ETYn connection functions 16
10.2	Ethernet PHY trail termination functions (ETYn_TT) 16
10.3	ETYn/ETH adaptation functions (ETYn/ETH_A)..... 20
10.4	1000BASE-(S/L/C)X ETY/Coding sub-layer adaptation functions (ETY3/ETC3_A) 27
11	Non-Ethernet server to ETH adaptation functions 27
11.1	SDH/ETH adaptation functions (S/ETH_A) 27
11.2	SDH/ETC adaptation functions (S4-X/ETC3_A) 47
11.3	S4-64c/ETH-w adaptation functions 47
11.4	PDH/ETH adaptation functions (P/ETH_A)..... 47

	Page
11.5 OTH/ETH adaptation functions (O/ETH_A)	47
11.6 MPLS/ETH adaptation functions (MPLS/ETH_A)	47
11.7 ATM VC/ETH adaptation functions (VC/ETH_A)	48
11.8 RPR/ETH adaptation functions (RPR/ETH_A)	48
Appendix I – Applications and functional diagrams	48

Introduction

This Recommendation forms part of a suite of Recommendations covering the full functionality of Ethernet transport network architecture and equipment (e.g., ITU-T Recs G.8010/Y.1306 and G.8012/Y.1308) and follows the principals defined in ITU-T Rec. G.805.

This Recommendation specifies a library of basic building blocks and a set of rules by which they may be combined in order to describe equipment used in an Ethernet transport network. The building blocks are based on atomic modelling functions defined in ITU-T Recs G.806 and G.809. The library comprises the functional building blocks needed to specify completely the generic functional structure of the Ethernet transport network. In order to be compliant with this Recommendation, the Ethernet functionality of any equipment which processes at least one of the Ethernet transport layers needs to be describable as an interconnection of a subset of these functional blocks contained within this Recommendation. The interconnections of these blocks should obey the combination rules given.

The specification method is based on functional decomposition of the equipment into atomic and compound functions. The equipment is then described by its Equipment Functional Specification (EFS) which lists the constituent atomic and compound functions, their interconnection, and any overall performance objectives (e.g., transfer delay, availability, etc.).

This is the first release of a planned series of releases of this Recommendation. This first release is intended to provide the necessary building blocks to support basic point-to-point connections of Ethernet ports over SDH transport networks (i.e., Ethernet Private Line (ITU-T Rec. G.8011.1/Y.1307.1)).

ITU-T Recommendation G.8021/Y.1341

Characteristics of Ethernet transport network equipment functional blocks

1 Scope

This Recommendation covers the functional requirements of Ethernet functionality within Ethernet transport equipment.

This Recommendation uses the specification methodology defined in ITU-T Rec. G.806 in general for transport network equipment and is based on the architecture of Ethernet layer networks defined in ITU-T Rec. G.8010/Y.1306, the interfaces for Ethernet transport networks defined in ITU-T Rec. G.8012/Y.1308, and in support of services defined in the G.8011.x/Y.1307 series of Recommendations. The description is generic and no particular physical partitioning of functions is implied. The input/output information flows associated with the functional blocks serve for defining the functions of the blocks and are considered to be conceptual, not physical.

The functionality defined in this Recommendation can be applied at User-to-Network Interfaces (UNI) and Network-to-Network Interfaces (NNI) of the Ethernet transport network.

Not every functional block defined in this Recommendation is required for every application. Different subsets of functional blocks from this Recommendation and others (e.g., ITU-T Recs G.783, G.798, G.806 and I.732) may be assembled in different ways according to the combination rules given in these Recommendations (e.g., ITU-T Rec. G.806) to provide a variety of different capabilities. Network operators and equipment suppliers may choose which functions must be implemented for each application.

The internal structure of the implementation of this functionality (equipment design) need not be identical to the structure of the functional model, as long as all the details of the externally observable behaviour comply with the Equipment Functional Specification (EFS).

Equipment developed prior to the production of this Recommendation may not comply in all details with this Recommendation.

The equipment requirements described in this Recommendation are generic and no particular physical partitioning of functions is implied. The input/output information flows associated with the functional blocks define the functions of the blocks and are considered to be conceptual, not physical.

Figure 1 presents a summary illustration of the set of atomic functions associated with the Ethernet signal transport. These atomic functions may be combined in various ways to support a variety of Ethernet services, some of which are illustrated in Appendix I. The functions for the processing of management communication channels (e.g., SDH DCC or OTH COMMS) are not shown in these Figures in order to reduce the complexity of the Figures. For DCC or COMMS functions, refer to the specific layer network descriptions.

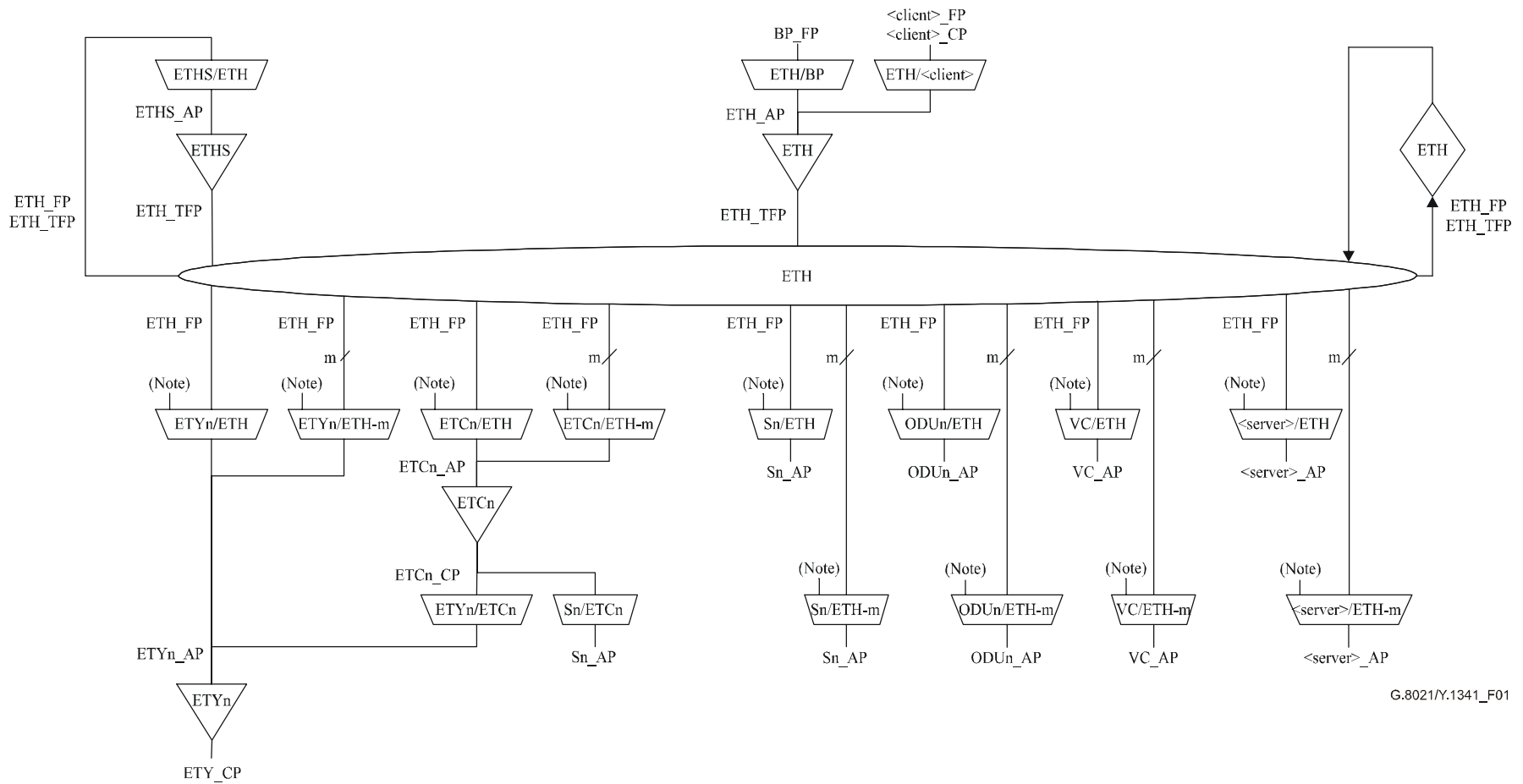

G.8021/Y.1341_F01

NOTE – ETH_TFP interface of adaptation functions towards the ETH_FT functions for logical link control. See ITU-T Rec. G.8010/Y.1306 and function definition for details.

Figure 1/G.8021/Y.1341 – Overview of G.8021/Y.1341 atomic model functions

2 References

The following ITU-T Recommendations and other references contain provisions which, through reference in this text, constitute provisions of this Recommendation. At the time of publication, the editions indicated were valid. All Recommendations and other references are subject to revision; users of this Recommendation are therefore encouraged to investigate the possibility of applying the most recent edition of the Recommendations and other references listed below. A list of the currently valid ITU-T Recommendations is regularly published. The reference to a document within this Recommendation does not give it, as a stand-alone document, the status of a Recommendation.

- ITU-T Recommendation G.707/Y.1322 (2003), *Network node interface for the synchronous digital hierarchy (SDH)*.
- ITU-T Recommendation G.709/Y.1331 (2003), *Interfaces for the optical transport network (OTN)*.
- ITU-T Recommendation G.783 (2004), *Characteristics of synchronous digital hierarchy (SDH) equipment functional blocks*.
- ITU-T Recommendation G.805 (2000), *Generic functional architecture of transport networks*.
- ITU-T Recommendation G.806 (2004), *Characteristics of transport equipment – Description methodology and generic functionality*.
- ITU-T Recommendation G.809 (2003), *Functional architecture of connectionless layer networks*.
- ITU-T Recommendation G.831 (2000), *Management capabilities of transport networks based on the synchronous digital hierarchy (SDH)*.
- ITU-T Recommendation G.841 (1998), *Types and characteristics of SDH network protection architectures*.
- ITU-T Recommendation G.874 (2001), *Management aspects of the optical transport network element*.
- ITU-T Recommendation G.957 (1999), *Optical interfaces for equipments and systems relating to the synchronous digital hierarchy*.
- ITU-T Recommendation G.959.1 (2003), *Optical transport network physical layer interfaces*.
- ITU-T Recommendation G.7041/Y.1303 (2003), *Generic Framing Procedure (GFP)*.
- ITU-T Recommendation G.7042/Y.1305 (2004), *Link capacity adjustment scheme (LCAS) for virtual concatenated signals*.
- ITU-T Recommendation G.8010/Y.1306 (2004), *Architecture of Ethernet layer networks*.
- ITU-T Recommendation G.8011/Y.1307 (2004), *Ethernet over Transport – Ethernet services framework*.
- ITU-T Recommendation G.8011.1/Y.1307.1 (2004), *Ethernet private line service*.
- ITU-T Recommendation G.8012/Y.1308 (2004), *Ethernet UNI and Ethernet NNI*.
- ITU-T Recommendation G.8251 (2001), *The control of jitter and wander within the optical transport network (OTN)*.
- IEEE 802-2001, *Local and Metropolitan Area Networks: IEEE Standard: Overview and Architecture*.

- IEEE Std. 802.1D-2004, *Information Technology – Telecommunications and Information Exchange Between Systems – Local and metropolitan Area Networks – Media Access Control (MAC) Bridges*.
- IEEE Std. 802.1Q-2003, *Local and Metropolitan Area Networks – Virtual Bridged Local Area Networks*.
- IEEE Std. 802.3-2002, *Information Technology – Local and Metropolitan Area Networks – Part 3: Carrier Sense Multiple Access with Collision Detection (CSMA/CD) Access Method and Physical Layer Specifications*.
- IEEE Std. 802.3ae-2002, *IEEE Standard for Information technology – LAN/MAN-Requirements: Part 3: Carrier Sense Multiple Access with Collision Detection (CSMA/CD) Access Method and Physical Layer Specifications – Amendment: Media Access Control (MAC) Parameters, Physical Layers, and Management. Parameters for 10 Gb/s Operation*.

3 Terms and definitions

This Recommendation uses the following terms defined in ITU-T Rec. G.8012/Y.1308:

3.1 User-to-Network Interface (UNI)

3.2 Network-to-Network Interface (NNI)

This Recommendation uses the following terms defined in ITU-T Rec. G.805:

3.3 access point

3.4 bidirectional reference point

3.5 connection point

3.6 link

3.7 link connection

3.8 network connection

3.9 trail

3.10 termination connection point

3.11 trail termination

3.12 service provider

3.13 network operator

This Recommendation uses the following terms defined in ITU-T Rec. G.806:

3.14 defects

3.15 consequent actions

3.16 defect correlations

3.17 performance filters

3.18 reference points

This Recommendation uses the following terms defined in ITU-T Rec. G.809:

3.19 access point

3.20 adaptation

3.21 adapted information

- 3.22 **characteristic information**
- 3.23 **client/server relationship**
- 3.24 **connectionless trail**
- 3.25 **flow**
- 3.26 **flow domain**
- 3.27 **flow domain flow**
- 3.28 **flow point**
- 3.29 **flow point pool**
- 3.30 **flow termination**
- 3.31 **flow termination sink**
- 3.32 **flow termination source**
- 3.33 **layer network**
- 3.34 **link flow**
- 3.35 **network**
- 3.36 **network flow**
- 3.37 **port**
- 3.38 **reference point**
- 3.39 **traffic unit**
- 3.40 **transport**
- 3.41 **transport entity**
- 3.42 **transport processing function**
- 3.43 **termination flow point**
- 3.44 **termination flow point pool**

This Recommendation uses the following term defined in ITU-T Rec. G.8010/Y.1306:

- 3.45 **traffic conditioning function**

This Recommendation uses the following term defined in ITU-T Rec. G.7041/Y.1303:

- 3.46 **Generic Framing Procedure (GFP)**

This Recommendation uses the following terms defined in IEEE 802.3 clause 1.4:

- 3.47 **10BASE-F**: IEEE 802.3 definition 1.4.3
- 3.48 **10BASE-T**: IEEE 802.3 definition 1.4.9
- 3.49 **100BASE-FX**: IEEE 802.3 definition 1.4.10
- 3.50 **100BASE-T**: IEEE 802.3 definition 1.4.11
- 3.51 **100BASE-TX**: IEEE 802.3 definition 1.4.14
- 3.52 **100BASE-X**: IEEE 802.3 definition 1.4.15
- 3.53 **1000BASE-CX**: IEEE 802.3 definition 1.4.16
- 3.54 **1000BASE-LX**: IEEE 802.3 definition 1.4.17
- 3.55 **1000BASE-SX**: IEEE 802.3 definition 1.4.18

- 3.56 **1000BASE-T**: IEEE 802.3 definition 1.4.19
- 3.57 **1000BASE-X**: IEEE 802.3 definition 1.4.20
- 3.58 **8B/10B transmission code**: IEEE 802.3 definition 1.4.24
- 3.59 **Auto-negotiation**: IEEE 802.3 definition 1.4.39
- 3.60 **Code-group**: IEEE 802.3 definition 1.4.77
- 3.61 **Comma**: IEEE 802.3 definition 1.4.84
- 3.62 **Full duplex**: IEEE 802.3 definition 1.4.135
- 3.63 **Jabber**: IEEE 802.3 definition 1.4.150
- 3.64 **Media Access Control (MAC)**: IEEE 802.3 definition 1.4.167
- 3.65 **Medium Attachment Unit (MAU)**: IEEE 802.3 definition 1.4.169
- 3.66 **Non-return-to-zero, Invert on ones (NRZI)**: IEEE 802.3 definition 1.4.183
- 3.67 **ordered set**: IEEE 802.3 definition 1.4.195
- 3.68 **Physical Coding Sublayer (PCS)**: IEEE 802.3 definition 1.4.210
- 3.69 **Physical Layer Entity (PHY)**: IEEE 802.3 definition 1.4.211
- 3.70 **Physical Medium Attachment (PMA) sublayer**: IEEE 802.3 definition 1.4.212
- 3.71 **Physical Medium Dependent (PMD) sublayer**: IEEE 802.3 definition 1.4.213
- 3.72 **Physical Signalling Sublayer (PLS)**: IEEE 802.3 definition 1.4.214
- 3.73 **Qtag prefix**: IEEE 802.3 definition 1.4.222
- 3.74 **Reconciliation Sublayer (RS)**: IEEE 802.3 definition 1.4.228
- 3.75 **Tagged MAC frame**: IEEE 802.3 definition 1.4.269
- 3.76 **Twisted pair**: IEEE 802.3 definition 1.4.276

This Recommendation defines the following terms:

3.77 Ethernet Termination Flow Replication Point (ETHTF_PP): Connection point between <Srv>/ETH adaptation source and sink. ETH_CI from source Ethernet Termination Flow Point (ETH_TFP) is replicated and delivered across ETHTF_PP to sink filter process.

3.78 Ethernet Flow Replication Point (ETHF_PP): Connection point between <Srv>/ETH adaptation source and sink. ETH_CI from source Ethernet Flow Point (ETH_FP) is replicated and delivered across ETHF_PP to sink Ethernet Termination Flow Point (ETH_TFP).

3.79 Ethernet Replicated Information (ETH_PI): Replicated ETH_CI delivered across ETHTF_PP or ETHF_PP.

4 Acronyms and abbreviations

This Recommendation uses the following abbreviations:

AI	Adapted Information
AP	Access Point
ATM	Asynchronous Transfer Mode
CI	Characteristic Information
CP	Connection Point

DA	Destination Address
EC	Ethernet Connection
EoA	Ethernet over ATM
EoM	Ethernet over MPLS
EoO	Ethernet over OTH
EoP	Ethernet over PDH
EoR	Ethernet over RPR
EoS	Ethernet over SDH
EoT	Ethernet over Transport
EPL	Ethernet Private Line
EPLAN	Ethernet Private LAN
ETC	Ethernet Coding
ETH	Ethernet MAC layer network
ETH_CI	Ethernet MAC Characteristic Information
ETY	Ethernet PHY layer
ETY _n	Ethernet PHY layer network of type <i>n</i>
EVC	Ethernet Virtual Connection
EVPL	Ethernet Virtual Private Line
EVPLAN	Ethernet Virtual Private LAN
EXM	Extension header Mismatch
FCS	Frame Check Sequence
FD	Flow Domain
FDF	Flow Domain Flow
FP	Flow Point
FT	Flow Termination
GFP	Generic Framing Procedure
GFP-F	Generic Framing Procedure – Frame Mapped
GFP-T	Generic Framing Procedure – Transparent Mapped
IEEE	Institute of Electronic and Electrical Engineers
IETF	Internet Engineering Task Force
LAN	Local Area Network
LAPS	Link access procedure – SDH
LCAS	Link Capacity Adjustment Scheme
LFD	Loss of Frame Delineation
LLC	Logical Link Control
LOS	Loss Of Signal
MAC	Media Access Control

MAU	Management Attachment Unit
MEF	Metro Ethernet Forum
MPLS	Multi-Protocol Label Switching
NNI	Network-to-Network Interface
NT	Network Termination
OAM	Operations, Administration, Maintenance
ODU	Optical Channel Data Unit
ODUj	Optical Channel Data Unit – order j
ODUj-Xv	Virtual concatenated Optical Channel Data Unit – order j
ODUk	Optical Channel Data Unit – order k
ODUk-Xv	Virtual concatenated Optical Channel Data Unit – order k
OTH	Optical Transport Hierarchy
P11s	1544 kbit/s PDH path layer with synchronous 125 μ s frame structure according to ITU-T Rec. G.704
P12s	2048 kbit/s PDH path layer with synchronous 125 μ s frame structure according to ITU-T Rec. G.704
P31s	34 368 kbit/s PDH path layer with synchronous 125 μ s frame structure according to ITU-T Rec. G.832
P4s	139 264 kbit/s PDH path layer with synchronous 125 μ s frame structure according to ITU-T Rec. G.832
PA	(Ethernet) Preamble
PCS	Physical Convergence Sublayer
PDH	Plesiochronous Digital Hierarchy
PHY	Physical Layer Entity
PLM	Path Label Mismatch
PLS	Physical Layer Signalling
PMA	Physical Medium Attachment sublayer
PMD	Physical Medium Dependent sublayer
POH	Path OverHead
QTag	IEEE 802.1Q tag
RFC	Request for Comments
RPR	Resilient Packet Ring
SA	Source Address
SDH	Synchronous Digital Hierarchy
SFD	Start of Frame Delimiter
SSF	Server Signal Fail
STM-N	Synchronous Transport Module – level N
TFP	Termination Flow Point

TSF	Trail Signal Fail
UNI	User Network Interface
UPI	GFP User Payload Identifier
UPM	User Payload Mismatch
VC	Virtual Channel (ATM) or Virtual Container (SDH)
VCAT	Virtual ConCATenation
VC-m	Lower Order VC – order m
VC-n	Higher Order VC – order n
VC-n-Xc	Contiguous concatenated VC – order n
VC-n-Xv	Virtual concatenated VC – order n
VLAN	Virtual LAN

5 Methodology

For the basic methodology to describe transport network functionality of network elements, refer to clause 5/G.806. For Ethernet-specific extensions to the methodology, see clause 5/G.8010/Y.1306.

6 Supervision

The generic supervision functions are defined in clause 6/G.806. Specific supervision functions for the Ethernet transport network are defined in this clause.

6.1 Defects

For defects, see ITU-T Rec. G.806 and the specific atomic functions.

6.2 Consequent actions

For consequent actions, see ITU-T Rec. G.806 and the specific atomic functions.

6.3 Defect correlations

For the defect correlations, see the specific atomic functions.

6.4 Performance filters

6.4.1 One-second performance monitoring filters associated with counts

For further study.

6.4.2 Performance monitoring filters associated with gauges

For further study.

7 Information flow across reference points

See clause 7/G.806 for the generic description of information flow. For Ethernet-specific information flow, see the description of the functions in clause 9.

8 Generic processes

Generic processes are defined in clause 8/G.806. This clause defines generic processes specific to equipment supporting the Ethernet transport network.

Figure 2 presents a high level view of the processes that are present in a generic Server to ETH adaptation function (<Srv>/ETH). The information crossing the <Srv>/ETH termination flow point (ETH_TFP) is referred to as the ETH characteristic information (ETH_CI). The information crossing the Server layer access point (<Srv>_AP) is referred to as the Server-specific adapted information (<Srv>_AI). Note that, for some server signals, not all processes need to be present, as defined in the server-specific adaptation functions.

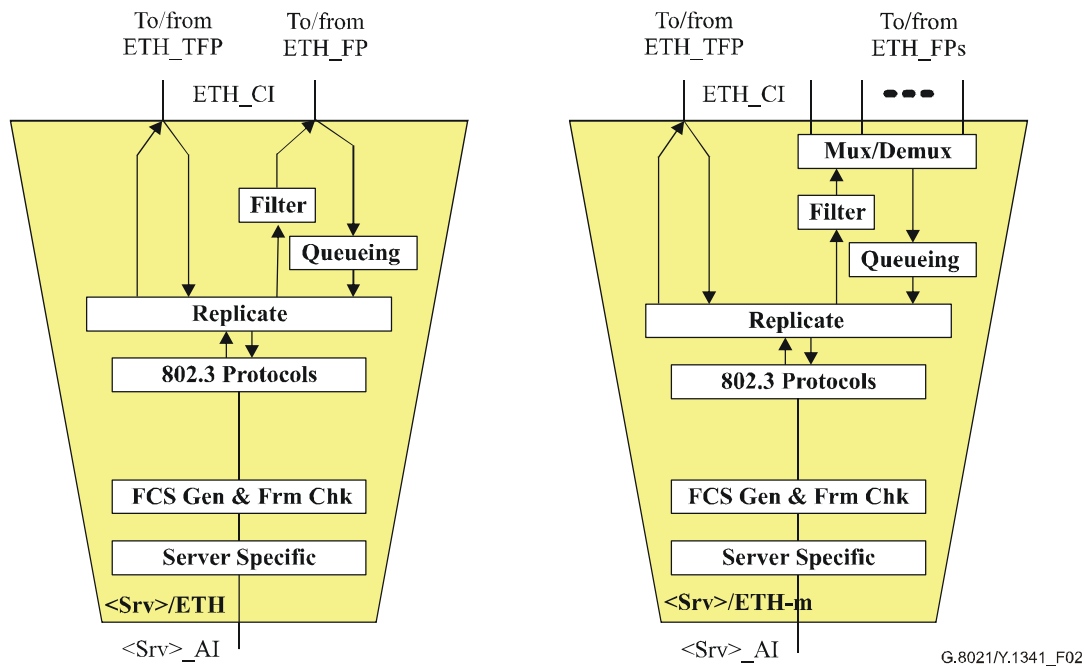

Figure 2/G.8021/Y.1341 – Server to ETH adaptation functions

The "Filter", "Queueing", "Mux/Demux", "Replicate", "802.3 Protocols", "MAC FCS Generate" and "MAC Frame Check" processes are defined in subsequent subclauses. Server-specific processes are specified in server-specific clauses.

Valid filter and layer 2 protocol actions for specific services are indicated in the G.8011.x/Y.1307 series of Recommendations for services supported by those Recommendations.

NOTE 1 – Filtering in <Srv>/ETH_A sink adaptation function is not applied to frames forwarded to the ETH_TFP. Rather, the ETH Flow Termination sink function (currently *for further study*) will include any necessary filtering of frames received across ETH_TFP from <Srv>/ETH_A.

NOTE 2 – Queuing of frames in the sink direction is also not applied. If queuing of frames in the sink direction is required when traffic conditioning is applied, this will be included in the Traffic Conditioning function (currently *for further study*).

NOTE 3 – For the G.8011.1/Y.1307.1 EPL service, ETH_TFP is unconnected. For services supporting ETH_TFP in the source direction, prioritization of frames received across the ETH_FP and ETH_TFP interfaces will be required. Such prioritization is *for further study*.

NOTE 4 – The IEEE 802.3ae-2002 Service Interface is supported within the atomic models. Its specific location is for further study.

8.1 Mux/Demux process

For further study.

8.2 Queuing process

The queuing process buffers received ETH frames for output (see Figure 3). The queuing process is also responsible for dropping frames if their rate at the ETH_CI is higher than the <Srv>_AI_D can accommodate, as well as maintaining PM counters for dropped frames. Additional performance monitor counters per IEEE 802.3-2002 clause 30 are *for further study*.

In response to RI_PauseRequest asserted, the queuing process halts the flow of frames to the Replicate process. Note that RI_PauseRequest is not connected in transport network equipment.

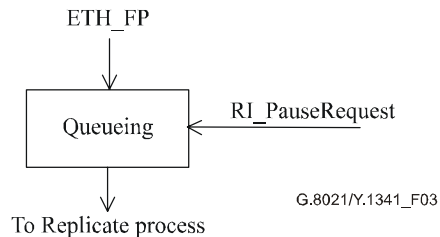

Figure 3/G.8021/Y.1341 – Queuing process

8.2.1 IEEE 802.1D queuing process

The IEEE 802.1D queuing process is applicable to <Srv>/ETH_A_Sk functions. This process is defined in IEEE 802.1D (clauses 7.7.3 and 7.7.4).

8.2.2 IEEE 802.1Q queuing process

The IEEE 802.1Q queuing process is applicable to <Srv>/ETH-m_A_Sk functions. This process is defined in IEEE 802.1Q (clauses 8.6.5 and 8.6.6).

8.3 Filter process

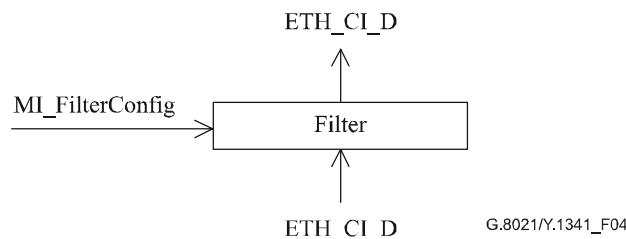

Figure 4/G.8021/Y.1341 – Filter process

The filter process maintains the filter action for each of the thirty-three group MAC addresses indicating control frames as defined in 6.3/G.8012/Y.1308. Valid filter actions are "pass" and "block". The filter action for these thirty-three MAC addresses can be configured separately. If the destination address of the incoming ETH_CI_D matches one of the above addresses, the filter process shall perform the corresponding configured filter action:

- Block: The frame is discarded by the filter process;
- Pass: The frame is passed unchanged through the filter process.

If none of the above addresses match, the ETH_CI_D is passed.

Valid filter actions for specific services are indicated in the G.8011.x/Y.1307 series of Recommendations for services supported by those Recommendations. The default filter action value shall be "pass" for all frames with the exception of MAC control frames for which the default value shall be "block".

8.4 Replicate process

See Figure 5.

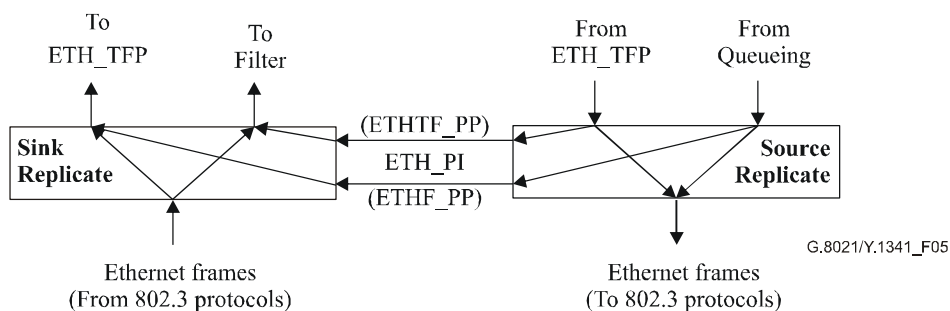

Figure 5/G.8021/Y.1341 – Replicate processes

The <Srv>/ETH_A_So replicate process shall:

- replicate ETH_CI traffic units received on the input from the queuing process and deliver them as ETH_PI to the ETHF_PP interface and the 802.3 protocols process;
- replicate ETH_CI traffic units received on the input from the ETH_TFP and deliver them as ETH_PI to the ETHTF_PP interface and 802.3 protocols process.

The <Srv>/ETH_A_Sk replicate process shall:

- replicate ETH_CI traffic units received on the input from the 802.3 protocols process and deliver them to the ETH_TFP and to the filter process;
- deliver ETH_PI traffic units received on the input from the ETHF_PP interface to the ETH_TFP;
- deliver ETH_PI traffic units received on the input from the ETHTF_PP to the filter process.

8.5 802.3 protocols processes

802.3 protocols processes include source and sink handling of MAC Control and optionally IEEE 802.3 slow protocols, as shown in Figure 6. The following subclauses specify processes for each of the illustrated process blocks.

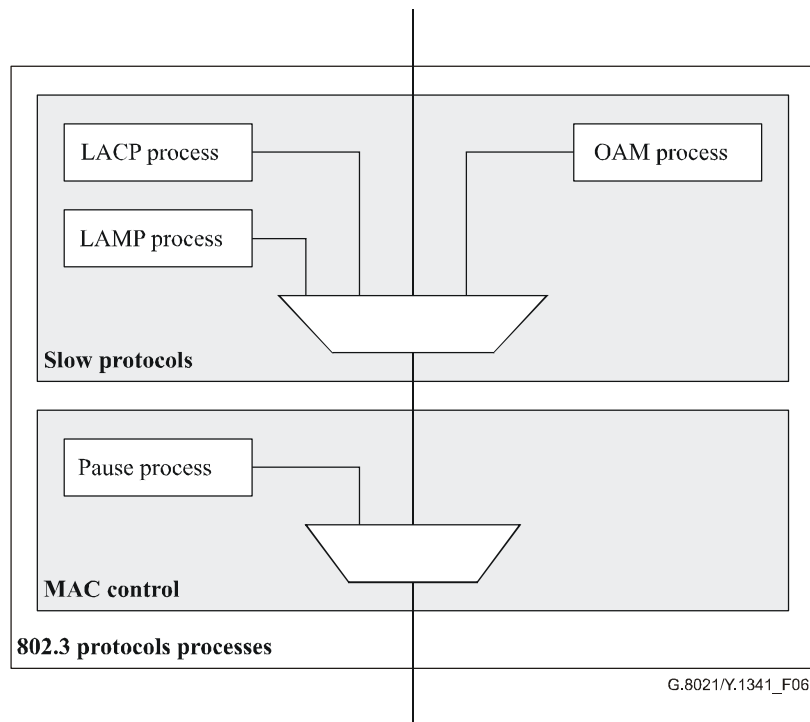

Figure 6/G.8021/Y.1341 – 802.3 protocols processes

8.5.1 MAC control process

The Ethernet MAC control function specified in IEEE 802.3-2002 clause 31 shall be implemented in all interfaces conforming to this Recommendation.

The process intercepts all MAC control frames, other frames are passed through unchanged. MAC control frames are characterized by the length/type value that is used (88-08). Every MAC control frame contains an opcode. MAC control frames are handled based on the value of the opcode. If the opcode is not supported, the frame is discarded. If the opcode is supported, the frame is processed by the corresponding MAC control function. In IEEE 802.3-2002, Annex 31A the opcode assignment is defined.

8.5.1.1 802.3 pause processes

The pause process handles MAC control frames with the opcode value 00-01, as described in IEEE 802.3, Annex 31B. There are two kinds of pause processes: Pause Transmit Process and Pause Receive Process.

8.5.1.1.1 Pause transmit process

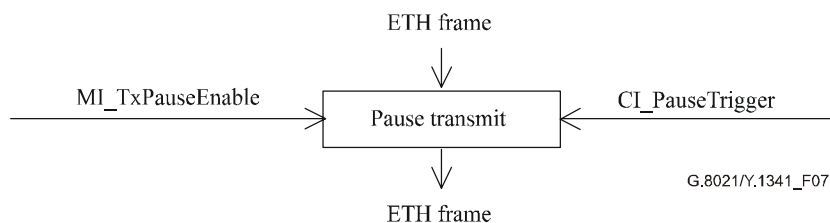

Figure 7/G.8021/Y.1341 – Transmit pause process

If enabled (`MI_TxPauseEnable = true`), this optional process generates pause frames according to IEEE 802.3 clause 31 and Annexes 31A and 31B.

The generation of the pause frame is triggered as soon as a CI_PauseTrigger is received. The CI_PauseTrigger primitive that has triggered the Pause frame generation conveys the pause_time parameter used in the generated pause frame.

The CI_PauseTrigger is generated as a result of the 802.3-2002 service interface signal MA_CONTROL.request described in 802.3-2002 clause 2.3.3. The generation of the MA_CONTROL.request is outside of the scope of this Recommendation.

8.5.1.1.2 Pause receive process

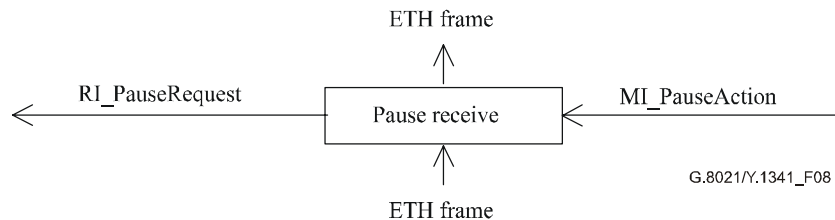

Figure 8/G.8021/Y.1341 – Receive pause process

On receipt of a pause frame, the corresponding action shall be performed according to the MI_PauseAction configuration. Valid actions are "block" and "process".

- Process: A received pause frame results in a RI_PauseRequest, conveying the received pause_time value, to the paired <Srv>/ETH_A_So.
- Block: Discard the received pause frame.

8.5.2 802.3 slow protocols processes

This optional process inspects all slow protocol frames, other frames are passed through unchanged. Slow protocol frames are characterized by the length/type value that is used (88-09). Every slow protocol frame contains a subtype field that distinguishes between different slow protocols. Table 43B-3 of IEEE 802.3-2002 defines the assignment of subtypes to protocols. The processing of the slow protocol frames depends on the value of the subtype field. There are three options:

- Illegal: The subtype field contains an illegal value (>10) and is discarded;
- Unsupported: The subtype field indicates a protocol that is not supported and the frame is passed through.
- Supported: The subtype field indicates a protocol that is supported, the frame is processed by the corresponding protocol function.

8.5.2.1 LACP process

For further study.

8.5.2.2 LAMP process

For further study.

8.5.2.3 OAM process

For further study.

8.6 MAC FCS generation

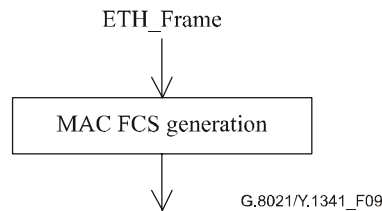

Figure 9/G.8021/Y.1341 – MAC FCS generation process

The MAC FCS is calculated over the ETH_CI traffic unit and inserted into the MAC FCS fields of the frame as defined in IEEE 802.3 subclause 4.2.3.1.2.

NOTE – For some server signals, MAC FCS generation is not supported. This will be defined in the server-specific adaptation functions.

8.7 MAC frame check

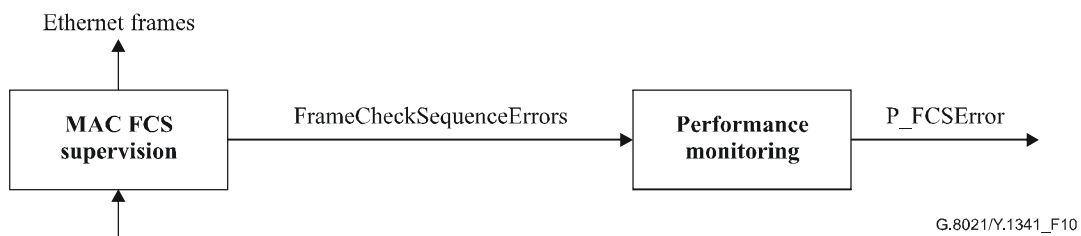

Figure 10/G.8021/Y.1341 – MAC frame check process

The MAC FCS is calculated over the ETH_CI traffic unit and checked as specified in IEEE 802.3 subclause 4.2.4.1.2. If errors are detected, the frame is discarded. Errored frames are indicated by FrameCheckSequenceErrors.

NOTE – For some server signals, MAC FCS supervision is not supported. This will be defined in the server-specific adaptation functions.

8.8 Link quality supervision

Counts of transmitted and received octets and frames are maintained in <Srv>/ETH_A functions per the requirements of IEEE 802.3 clause 30. Discarded jabber frames are counted in ETYn/ETH_A_So functions.

Additional link quality performance monitors per IEEE 802.3-2002 clause 30 are for further study.

8.9 FDI/BDI generation and detection

For further study.

9 Ethernet MAC layer (ETH) functions

9.1 ETH flow forwarding functions

For further study.

9.2 ETH flow termination functions (ETH_FT)

For further study.

9.3 Ethernet/client adaptation functions

For further study.

9.4 Traffic conditioning function (ETH_TC)

For further study.

9.5 ETH segment sub-layer functions

For further study.

10 Ethernet PHY layer (ETYn) functions

This Recommendation supports the following full-duplex Ethernet PHYs:

- ETY1: 10BASE-T (twisted pair electrical; full-duplex only);
- ETY2.1: 100BASE-TX (twisted pair electrical; full-duplex only; *for further study*);
- ETY2.2: 100BASE-FX (optical; full-duplex only; *for further study*);
- ETY3.1: 1000BASE-T (copper; *for further study*);
- ETY3.2: 1000BASE-LX/SX (long- and short-haul optical; full duplex only);
- ETY3.3: 1000BASE-CX (short-haul copper; full duplex only; *for further study*);
- ETY4: 10GBASE-S/L/E (optical; *for further study*).

10.1 ETYn connection functions

Not applicable; there are no connection functions defined for this layer.

10.2 Ethernet PHY trail termination functions (ETYn_TT)

In the sink direction, Ethernet PHY trail termination functions (ETYn_TT) terminate received optical or electrical Ethernet signals, delivering a conditioned signal to the ETYn/ETH_Sk_A sink adaptation function. In the source direction, ETYn_TT trail termination accepts an electrical signal from the ETYn/ETH_So_A source adaptation function, and outputs an appropriate electrical or optical signal to the Ethernet electrical or optical delivery medium.

For each of the ETYn_TT functions, a similar set of source and sink processes is required. Tables in the following subclauses specify ETYn_TT functions by incorporating references to appropriate clauses in IEEE 802.3 for the various PHY types.

Allocation of Link Test Fail and Auto-Negotiation related functionality to ETYn trail termination or ETYn/ETH adaptation is *for further study*.

10.2.1 ETYn Trail Termination Source function (ETYn_TT_So)

Symbol

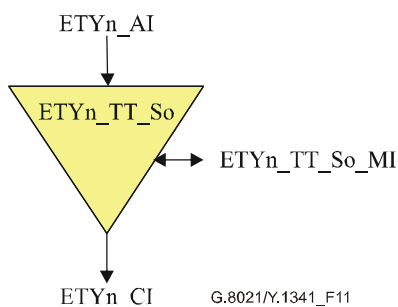

Figure 11/G.8021/Y.1341 – ETYn_TT_So symbol

Interfaces

Table 1/G.8021/Y.1341 – ETYn_TT_So interfaces

Inputs	Outputs
ETYn_AI_Data ETYn_AI_Clock ETYn_TT_So_MI_PHYType ETYn_TT_So_MI_PHYTypeList	ETYn_CI_Data ETYn_CI_Clock

Processes

ETYn_TT_So process	ETYn type	IEEE 802.3 specifying clauses
Transmit process	ETY1	14.2.1.1 Transmit function requirements 14.2.2.2 PMA to twisted-pair messages 14.3.1.1 Isolation requirements 14.3.1.2 Transmitter specifications
	ETY2.1	100BASE-TX (<i>for further study</i>)
	ETY2.2	100BASE-FX (clause 26; <i>for further study</i>)
	ETY3.1	1000BASE-T (<i>for further study</i>)
	ETY3.2	1000BASE-LX/SX: clause 38 source processes
	ETY3.3	1000BASE-CX (clause 39; <i>for further study</i>)
	ETY4	10GBASE-S/L/E (<i>for further study</i>)

ETY1_TT_So (10BASE-T) Transmit process:

Transfers ETY1_AI_Data containing Manchester-encoded data from the ETY1/ETH_So_A to the twisted pair electrical medium.

ETY2.1_TT_So (100BASE-TX) Transmit process:

For further study.

ETY2.2_TT_So (100BASE-FX) Transmit process:

For further study.

ETY3.1_TT_So (1000BASE-T) Transmit process:

For further study.

ETY3.2_TT_So (1000BASE-SX/LX) Transmit process:

Converts received ETY1_AI_Data containing 8B/10B-encoded data and control into optical signals delivered to the optical medium. Requirements of IEEE 802.3 clauses 38.2.2, 38.3, 38.3.1, 38.3.3 and 38.5 apply to SX transmitters; clauses 38.2.2, 38.4, 38.4.1, 38.4.3 and 38.5 apply to LX transmitter.

ETY3.3_TT_So (1000BASE-CX) Transmit process:

For further study.

ETY4_TT_So (10GBASE-S/L/E) Transmit process:

For further study.

Defects

None.

Consequent actions

None.

Defect correlations

None.

Performance monitoring

None.

10.2.2 ETYn Trail Termination Sink function (ETYn_TT_Sk)

Symbol

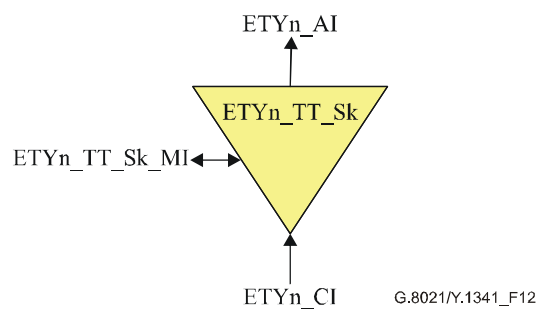

Figure 12/G.8021/Y.1341 – ETYn_TT_Sk symbol

Interfaces

Table 2/G.8021/Y.1341 – ETYn_TT_Sk interfaces

Inputs	Outputs
ETYn_CI_Data	ETYn_AI_Data ETYn_AI_Clock ETYn_AI_TSF ETYn_TT_Sk_MI_cLOS

Processes

ETYn_TT_Sk process	ETYn type	IEEE 802.3 specifying clauses
Receive process	ETY1	10BASE-T: 14.2.1.2 Receive function requirements 14.2.2.3 Twisted-pair to PMA messages 14.3.1.1 Isolation requirements 14.3.1.3 Receiver specifications
	ETY2.1	100BASE-TX (clause 25 sink processes <i>for further study</i>)
	ETY2.2	100BASE-FX (clause 26 sink processes <i>for further study</i>)
	ETY3.1	1000BASE-T (<i>for further study</i>)
	ETY3.2	1000BASE-LX/SX: clause 38 sink processes
	ETY3.3	1000BASE-CX (clause 39; <i>for further study</i>)
	ETY4	10GBASE-S/L/E (<i>for further study</i>)

ETY1 (10BASE-T) Receive process:

Transfers Manchester-encoded ETYn_CI_Data from the twisted pair electrical medium to the ETY1/ETH_Sk_A function. Detects and reports dLOS.

ETY2.1_TT_Sk (100BASE-TX) Receive process:

For further study.

ETY2.2_TT_Sk (100BASE-FX) Receive process:

For further study.

ETY3.1_TT_Sk (1000BASE-T) Receive process:

For further study.

ETY3.2_TT_Sk (1000BASE-SX/LX) Receive process:

Converts optical signal (ETY3.2_CI_Data) received from the optical medium into an 8B/10B-coded signal stream. Detects and reports dLOS. Conditions signal for clock and data recovery process such that receive jitter requirements are met. O/E conversion and signal detection per IEEE 802.3 38.2.3 and 38.2.4. Clauses 38.3.2, 38.3.3, and 38.5 apply to SX receiver; 38.4.2, 38.4.3 and 38.5 apply to LX receiver.

ETY3.3_TT_Sk (1000BASE-CX) Receive process:

For further study.

ETY4_TT_Sk (10GBASE-S/L/E) Receive process:

For further study.

Defects

dLOS: (Detection criteria are ETYn PHY specific and are for further study.)

Consequent actions

aTSF ← dLOS.

Defect correlations

cLOS ← dLOS.

Performance monitoring

None.

10.3 ETYn/ETH adaptation functions (ETYn/ETH_A)

Figures 13 and 14 illustrate Ethernet trail termination to ETH adaptation functions (ETYn/ETH_A and ETYn/ETH-m_A). Information crossing the ETH flow point (ETH_FP) and ETH termination flow point (ETH_TFP) is referred to as ETH characteristic information (ETH_CI). Information crossing the ETYn access point (ETYn_AP) is referred to as ETYn adapted information (ETYn_AI).

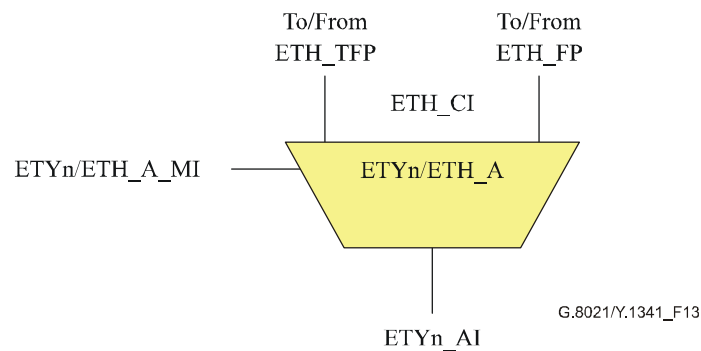

Figure 13/G.8021/Y.1341 – ETYn server to ETH adaptation function

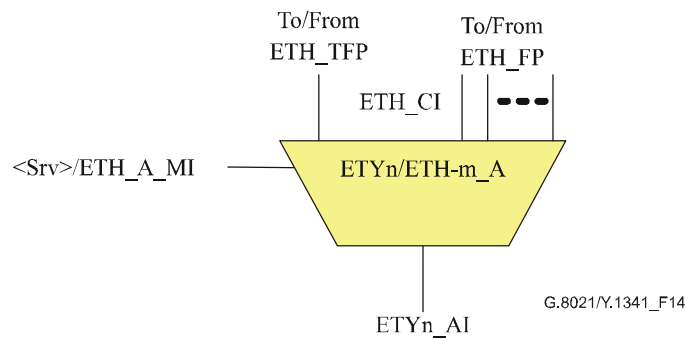
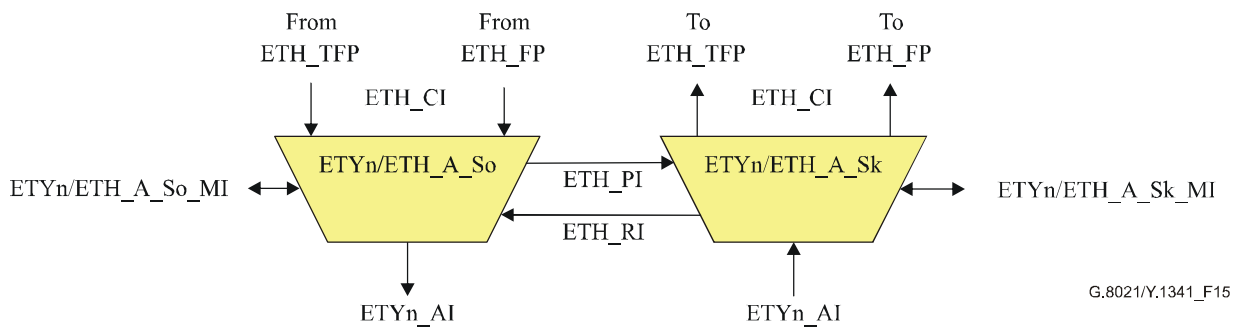

Figure 14/G.8021/Y.1341 – ETYn/ETH adaptation function (Multiple Flow Point)

The ETY_n/ETH_A adaptation function shown in Figure 13 can be further decomposed into separate source and sink adaptation functions shown in Figure 15:



G.8021/Y.1341_F15

Figure 15/G.8021/Y.1341 – ETY_n/ETH_A source and sink adaptation functions

Likewise, ETY_n/ETH-m_A multiplexed flow adaptation function shown in Figure 14 can be decomposed into separate source and sink adaptation functions shown in Figure 16:

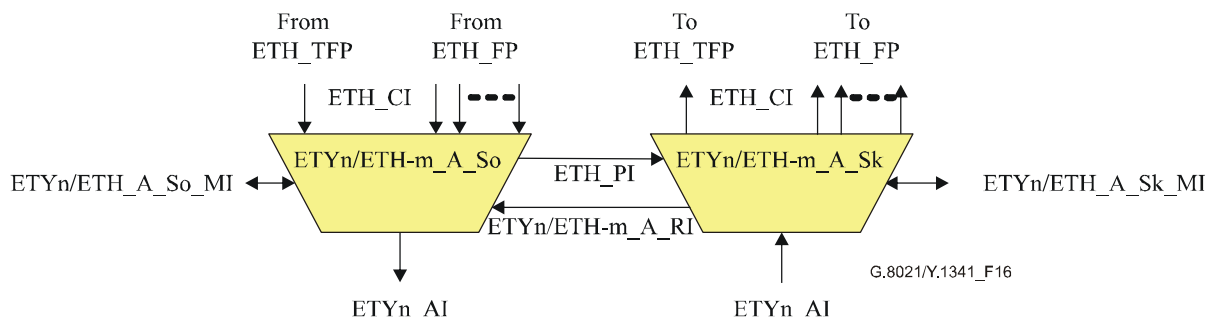

G.8021/Y.1341_F16

Figure 16/G.8021/Y.1341 – ETY_n/ETH-m_A source and sink adaptation functions

10.3.1 ETY_n/ETH_A adaptation source function (ETY_n/ETH_A_So)

Symbol

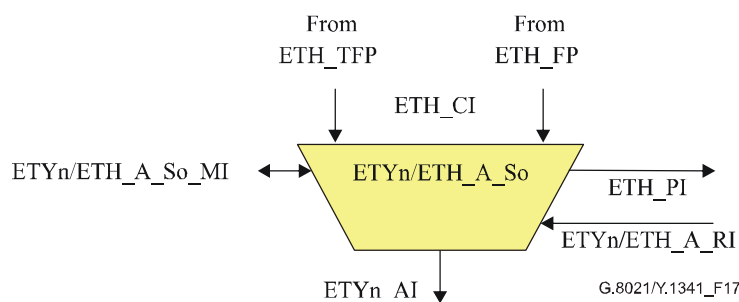

G.8021/Y.1341_F17

Figure 17/G.8021/Y.1341 – ETY_n/ETH_A_So symbol

Interfaces

Table 3/G.8021/Y.1341 – ETYn/ETH_A_So interfaces

Inputs	Outputs
ETH_CI_Data	ETYn_AI_Data
ETH_CI_Clock	ETYn_AI_Clock
ETYn/ETH_A_CI_PauseTrigger	ETH_PI_Data
ETYn/ETH_A_RI_PauseRequest	ETYn/ETH_A_So_MI_Jabber
ETYn/ETH_A_So_MI_TxPauseEnable	ETYn/ETH_A_So_MI_FramesTransmittedOK
	ETYn/ETH_A_So_MI_OctetsTransmittedOK

Processes

A process diagram of this function is shown in Figure 18.

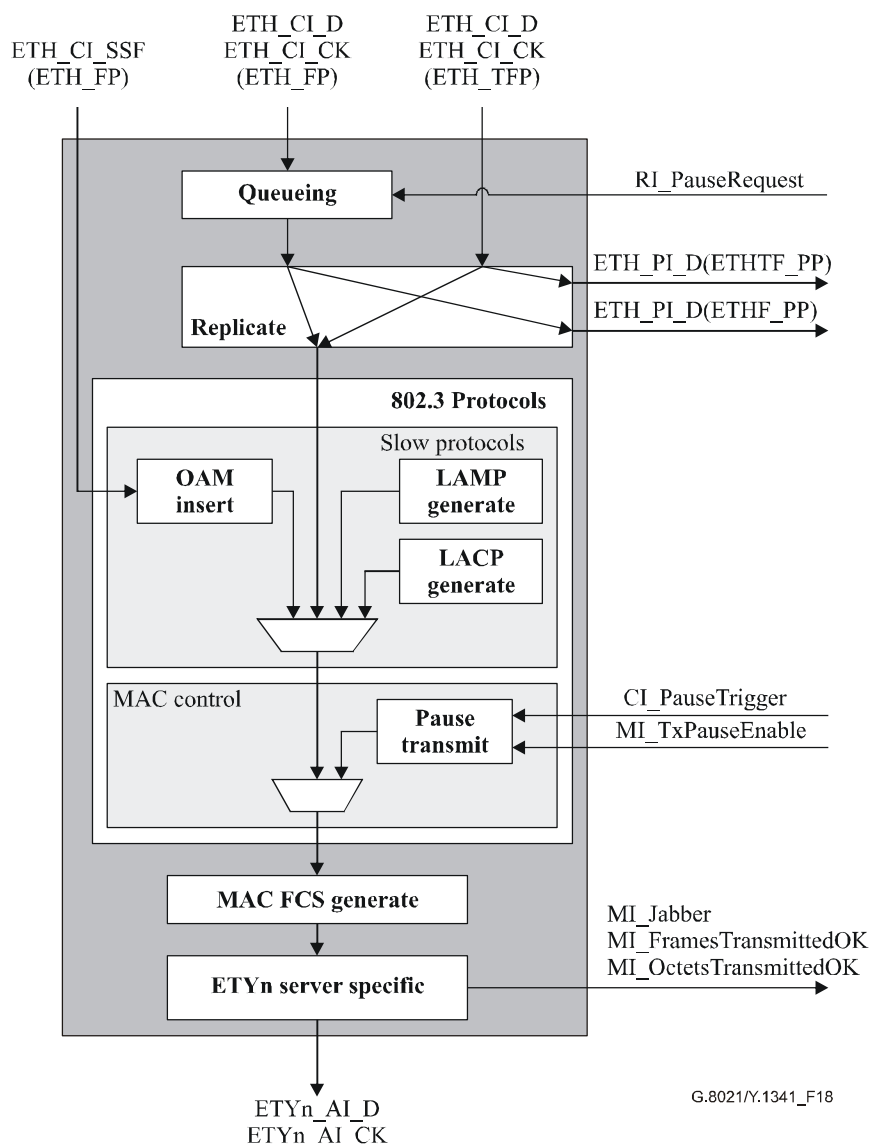

Figure 18/G.8021/Y.1341 – ETYn/ETH_A_So process diagram

The "Queuing", "Replicate", "OAM Insert", "LAMP Generate", "LACP Generate", "Pause Transmit", and "MAC FCS Generate" processes are defined in clause 8 (Generic processes).

The "ETYn Server-specific" source processes are described below:

ETYn/ETH_A_So process	ETYn type	IEEE 802.3 specifying clauses
PLS source processes Jabber source process Transmit source process	ETY1	7.2 PLS Functional specification 7.3.1.1 Data encoding (TX) 14.2.1.6 Jabber function 14.3.1.2 Transmitter specifications 14.2.3 MAU State Diagrams
	ETY2.1	100BASE-T (clause 25; <i>for further study</i>)
	ETY2.2	100BASE-X (<i>for further study</i>)
	ETY3.1	1000BASE-T (<i>for further study</i>)
Frame delivery process 8B/10B Encoding and rate adaptation Auto-negotiation source process	ETY3.2 and .3	1000BASE-X RS source process Clause 35; 1000BASE-X clause 36 1000BASE-X clause 37
	ETY4	10GBASE-R (<i>for further study</i>)

ETY1/ETH source adaptation processes:

For 10BASE-T, Ethernet frames are delivered to the Physical Layer Signalling (PLS) source process one bit at a time. The PLS applies Manchester-encoding to received bits, delivering the encoded data (ETY1_AI) to the ETY1 trail termination source (ETY1_TT_So).

The Jabber process prevents the PLS from sending frames that are too large.

ETY2/ETH source adaptation processes:

For further study.

ETY3.1/ETH source adaptation processes:

For further study.

ETY3.2/ETH and ETY3.3/ETH source adaptation processes:

The Reconciliation Sublayer (RS) source process delivers MAC frame data from the ETYn server-independent MAC FCS generate process to the 8B/10B encoding process.

The 8B/10B encoding process converts received data and control words from the RS source process into 8B/10B codewords per IEEE 802.3 clause 36. This process performs rate adaptation by Idle insertion per clause 36.

ETY4/ETH source adaptation processes:

For further study.

Defects

None.

Consequent actions

None.

Defect correlations

None.

Performance monitoring

MI_Jabber count per IEEE 802.3 clause 30.

MI_OctetsTransmittedOK per IEEE 802.3 clause 30.

MI_FramesTransmittedOK per IEEE 802.3 clause 30.

10.3.2 ETYn/ETH_A adaptation sink function (ETYn/ETH_A_Sk)

Symbol

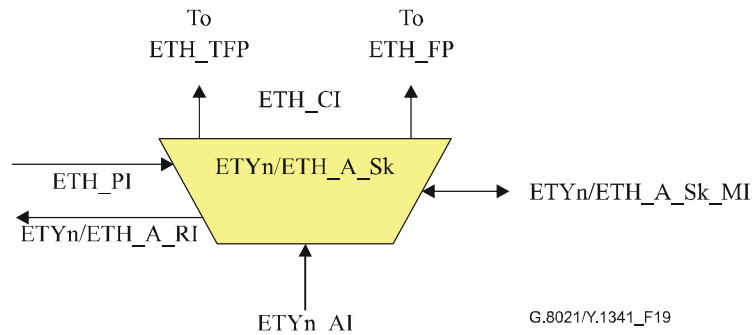

Figure 19/G.8021/Y.1341 – ETYn/ETH_A_Sk symbol

Interfaces

Table 4/G.8021/Y.1341 – ETYn/ETH_A_Sk interfaces

Inputs	Outputs
ETYn_AI_Data	ETH_CI_Data
ETYn_AI_Clock	ETH_CI_Clock
ETH_PI_Data	ETH_CI_SSF
ETYn/ETH_A_Sk_MI_FilterConfig	ETYn/ETH_A_RI_PauseRequest
ETYn/ETH_A_Sk_MI_PauseAction	ETYn/ETH_A_Sk_MI_FCSErrors
	ETYn/ETH_A_Sk_MI_FramesReceivedOK
	ETYn/ETH_A_Sk_MI_OctetsReceivedOK

Processes

A process diagram of this function is shown in Figure 20.

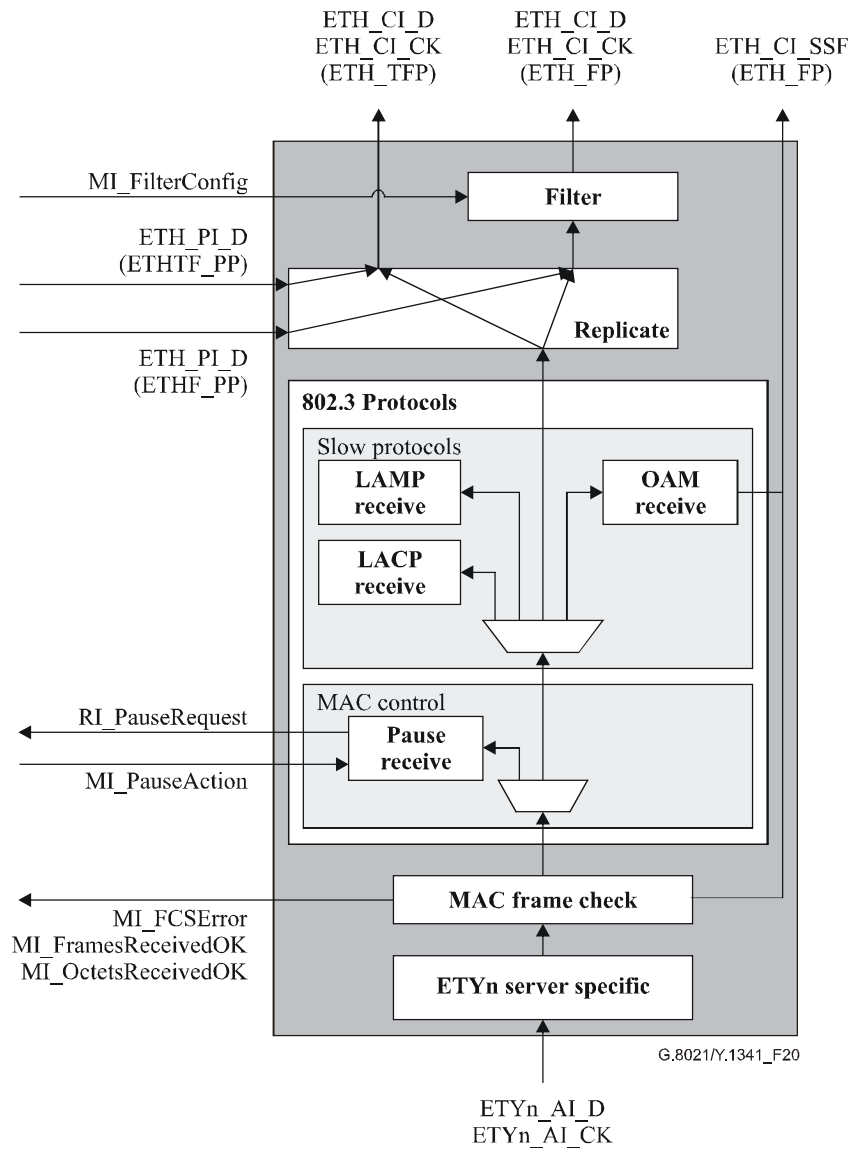

Figure 20/G.8021/Y.1341 – ETYn/ETH_A_Sk process diagram

The "Filter", "Replicate", "MAC frame check", "Pause receive", "OAM receive", "LAMP receive", and "LACP receive" processes are defined in clause 8 (Generic processes).

The "ETYn server-specific" sink processes are described below:

ETYn/ETH_A_Sk process	ETYn type	IEEE 802.3 specifying clauses
Clock and Data recovery PLS sink processes	ETY1	14.3.1.3 Receiver specifications 14.2.3 MAU State Diagrams 7.2 PLS functional specification 7.3.1.1 Data encoding
	ETY2.1	100BASE-T (clause 25; <i>for further study</i>)
	ETY2.2	100BASE-X (<i>for further study</i>)
	ETY3.1	1000BASE-T (<i>for further study</i>)
Clock and Data recovery	ETY3.2	1000BASE-LX/SX per clause 38
8B/10B codeword synchronization	ETY3.3	1000BASE-CX per clause 39 (<i>for further study</i>)
Frame delineation	ETY3.2 and .3	1000BASE-X per clause 36
Auto-negotiation sink processes	ETY3.2 and .3	1000BASE-X per clauses 35 and 36
	ETY3.2 and .3	1000BASE-X Auto-Negotiation per clauses 36, 37
	ETY4	10GBASE-R (<i>for further study</i>)

ETY1/ETH sink adaptation processes:

The Management Attachment Unit (MAU) sink process recovers clock and data from link test pulses and Manchester-encoded data received from the ETY1_TT_Sk function on ETYn_CI_Data.

The Physical Layer Signalling (PLS) sink process decodes received Manchester-encoded data and delivers the decoded bitstream to the server-independent MAC frame checking process.

ETY2/ETH sink adaptation processes:

For further study.

ETY3.1/ETH sink adaptation processes:

For further study.

ETY3.2/ETH and ETY3.3/ETH sink adaptation processes:

Clock and data recovery is performed per IEEE 802.3 clauses 38 (LX/SX) and 39 (CX). If clock cannot be recovered from the received signal, a local reference clock is substituted as the 125 MHz clock delivered to the MAC frame check process.

The 8B/10B decoding process performs codeword alignment and loss-of-codeword synchronization detection per IEEE 802.3 clause 36.

Frame delineation is performed in the Physical Convergence Sublayer (PCS) per IEEE 802.3 clause 36. Delineated frames are forwarded to ETYn server-independent MAC frame check process per the Reconciliation Sublayer (RS) process per IEEE 802.3 clause 36. The RS process forwards an error indication to the MAC frame check process if 8B/10B decoding detects an error. Idle is forwarded in the absence of received frame data.

ETY4/ETH sink adaptation processes:

For further study.

Defects

None.

Consequent actions

aSSF ← AI_TSF

Defect correlations

None.

Performance monitoring

MI_FramesReceivedOK per IEEE 802.3 clause 30.

MI_OctetsReceivedOK per IEEE 802.3 clause 30.

MI_FCSErrors per IEEE 802.3 clause 30.

10.4 1000BASE-(S/L/C)X ETY/Coding sub-layer adaptation functions (ETY3/ETC3_A)

This adaptation function adapts 1000BASE-SX, -LX, or -CX physical layer signals from/to 8B/10B-encoded codewords. Codewords may be extracted from or mapped into GFP-T frames, per 11.2 SDH/ETC Adaptation functions (S4-X/ETC3_A).

For further study.

11 Non-Ethernet server to ETH adaptation functions

11.1 SDH/ETH adaptation functions (S/ETH_A)

11.1.1 VC-n/ETH adaptation functions (Sn/ETH_A; n = 3, 3-X, 4, 4-X)

This covers non-concatenated, contiguously concatenated, and non-LCAS VCAT. See 11.1.2 for LCAS-capable VC-n-Xv/ETH adaptation functions.

11.1.1.1 VC-n/ETH adaptation source function (Sn/ETH_A_So)

This function maps ETH_CI information onto an Sn_AI signal (n = 3, 3-X, 4, 4-X).

Data at the Sn_AP is a VC-n (n = 3, 3-X, 4, 4-X), having a payload as described in ITU-T Rec. G.707/Y.1322, but with indeterminate POH bytes: J1, B3, G1.

Symbol

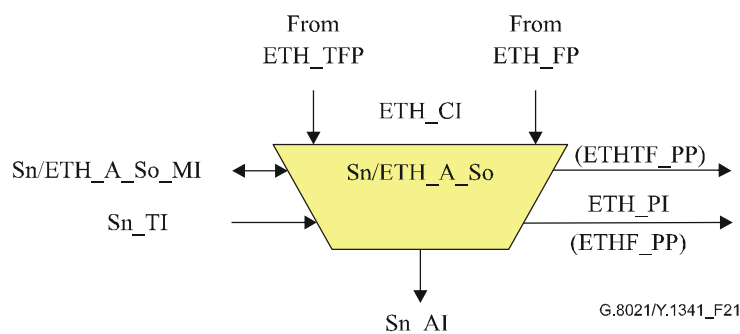

Figure 21/G.8021/Y.1341 – Sn/ETH_A_So symbol

Interfaces

Table 5/G.8021/Y.1341 – Sn/ETH_A_So interfaces

Inputs	Outputs
ETH_TFP: ETH_CI_Data	Sn_AP: Sn_AI_Data Sn_AI_Clock Sn_AI_FrameStart
ETH_FP: ETH_CI_Data ETH_CI_SSF	ETHF_PP: ETH_PI_Data
Sn_TI: Sn_TI_Clock Sn_TI_FrameStart	ETHTF_PP: ETH_PI_Data
Sn/ETH_A_So_MI: Sn/ETH_A_So_MI_CSFEnable	

Processes

A process diagram of this function is shown in Figure 22.

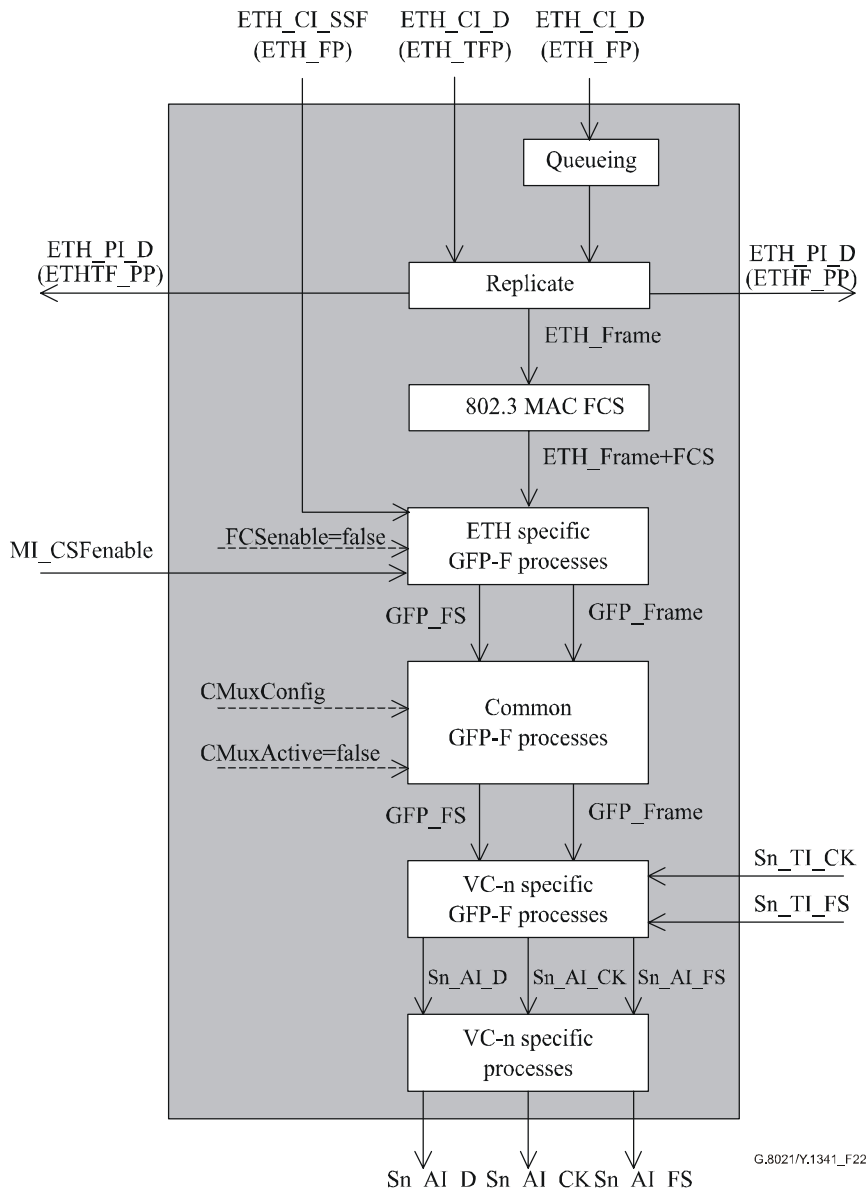

Figure 22/G.8021/Y.1341 – Sn/ETH_A_So process diagram

"Queuing" process:

See 8.2.

"Replicate" process:

See 8.4.

802.3 MAC FCS generation:

See 8.6.

Ethernet specific GFP-F source process:

See 8.5.4.1.1/G.806. GFP pFCS generation is disabled (FCSEnable=false). The UPI value for frame-mapped Ethernet shall be inserted (Table 6-3/G.7041/Y.1303). The Ethernet frames are inserted into the client payload information field of the GFP-F frames according to 7.1/G.7041/Y.1303.

Response to ETH_CI_SSF asserted is *for further study*.

Common GFP source process:

See 8.5.3.1/G.806. GFP channel multiplexing is not supported (CMuxActive=false).

VC-n specific GFP source process:

See 8.5.2.1/G.806. The GFP frames are mapped into the VC-n payload area according to 10.6/G.707/Y.1322.

VC-n specific source process:

C2: Signal label information is derived directly from the Adaptation function type. The value for "GFP mapping" in Table 9-11/G.707/Y.1322 is placed in the C2 byte position.

H4: For Sn/ETH_A_So with n = 3, 4, the H4 byte is sourced as all-zeros.

NOTE 1 – For Sn/ETH_A_So with n = 3-X, 4-X, the H4 byte is undefined at the Sn-X_AP output of this function (as per clause 12/G.783).

NOTE 2 – For Sn/ETH_A_So with n = 3, 4, 3-X, 4-X, the K3, F2, F3 bytes are undefined at the Sn-X_AP output of this function (as per clause 12/G.783).

Defects

None.

Consequent actions

None.

Defect correlations

None.

Performance monitoring

For further study.

11.1.1.2 VC-n/ETH adaptation sink function (Sn/ETH_A_Sk)

This function extracts ETH_CI information from the Sn_AI signal (n = 3, 3-X, 4, 4-X), delivering ETH_CI to ETH_TFP and ETH_FP.

Data at the Sn_AP is as described in ITU-T Rec. G.707/Y.1322.

Symbol

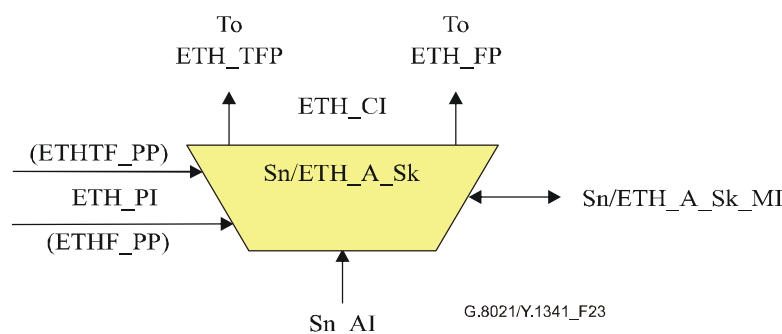

Figure 23/G.8021/Y.1341 – Sn/ETH_A_Sk symbol

Interfaces

Table 6/G.8021/Y.1341 – Sn/ETH_A_Sk interfaces

Inputs	Outputs
<p>Sn_AP: Sn_AI_Data Sn_AI_ClocK Sn_AI_FrameStart Sn_AI_TSF</p> <p>ETHF_PP: ETH_PI_Data</p> <p>ETHTF_PP: ETH_PI_Data</p> <p>Sn/ETH_A_Sk_MI: Sn/ETH_A_Sk_MI_FilterConfig Sn/ETH_A_Sk_MI_CSF_Reported</p>	<p>ETH_TFP: ETH_CI_Data ETH_CI_SSF</p> <p>ETH_FP: ETH_CI_Data ETH_CI_SSF</p> <p>Sn/ETH_A_Sk_MI: Sn/ETH_A_Sk_MI_AcSL Sn/ETH_A_Sk_MI_AcEXI Sn/ETH_A_Sk_MI_AcUPI Sn/ETH_A_Sk_MI_cPLM Sn/ETH_A_Sk_MI_cLFD Sn/ETH_A_Sk_MI_cUPM Sn/ETH_A_Sk_MI_cEXM Sn/ETH_A_Sk_MI_cCSF Sn/ETH_A_Sk_MI_pFCSErrors</p>

Processes

A process diagram of this function is shown in Figure 24.

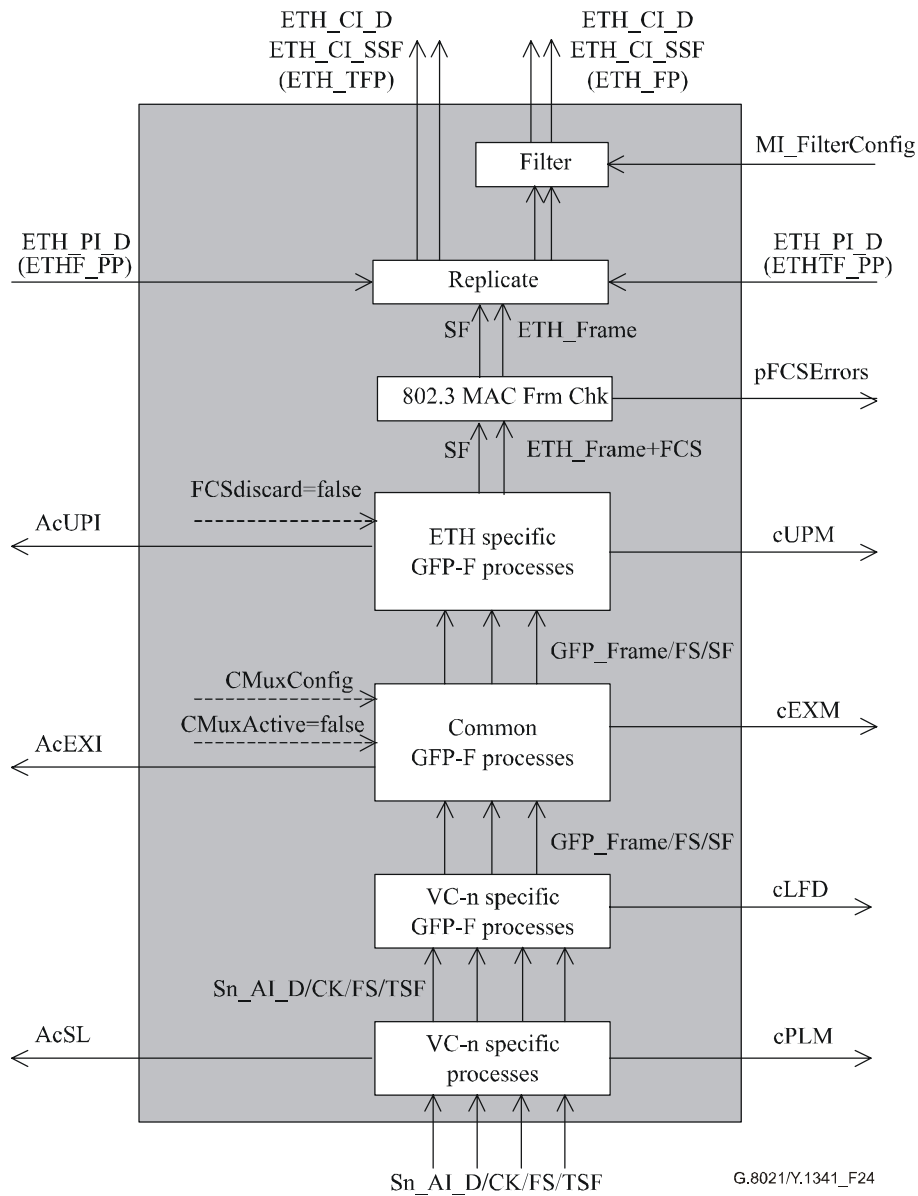

Figure 24/G.8021/Y.1341 – Sn/ETH_A_Sk process diagram

"Filter" process:

See 8.3.

"Replicate" process:

See 8.4.

"802.3 MAC Frame Check" process:

See 8.7.

Ethernet specific GFP-F sink process:

See 8.5.4.1.2/G.806. GFP pFCS checking, GFP p_FCSError, p_FDis are not supported (FCSdiscard=false). The UPI value for Frame-Mapped Ethernet shall be expected (Table 6-3/G.7041/Y.1303). The Ethernet frames are extracted from the client payload information field of the GFP-F frames according to 7.1/G.7041/Y.1303.

Common GFP sink process:

See 8.5.3.1/G.806. GFP channel multiplexing is not supported (MI_CMuxActive=false).

VC-n specific GFP sink process:

See 8.5.2.1/G.806. The GFP frames are demapped from the VC-n payload area according to 10.6/G.707/Y.1322.

VC-n specific sink process:

C2: The signal label is recovered from the C2 byte as per 6.2.4.2/G.806. The signal label for "GFP mapping" in Table 9-11/G.707/Y.1322 shall be expected. The accepted value of the signal label is also available at the Sn/ETH_A_Sk_MP.

Defects

dPLM – See 6.2.4.2/G.806.

dLFD – See 6.2.5.2/G.806.

dUPM – See 6.2.4.3/G.806.

dEXM – See 6.2.4.4/G.806.

Consequent actions

The function shall perform the following consequent actions:

aSSF ← AI_TSF or dPLM or dLFD or dUPM or dEXM or dCSF

Defect correlations

The function shall perform the following defect correlations to determine the most probable fault cause (see 6.4/G.806). This fault cause shall be reported to the EMF.

cPLM ← dPLM and (not AI_TSF);

cLFD ← dLFD and (not dPLM) and (not AI_TSF);

cUPM ← dUPM and (not dPLM) and (not dLFD) and (not AI_TSF);

cEXM ← dEXM and (not dUPM) and (not dPLM) and (not dLFD) and (not AI_TSF);

cCSF per 8.5.4.1.2/G.806.

Performance monitoring

The function shall perform the following performance monitoring primitives processing. The performance monitoring primitives shall be reported to the EMF.

pFCSErrors: count of FrameCheckSequenceErrors per second.

NOTE – This primitive is calculated by the MAC Frame Check process.

11.1.2 LCAS-capable VC-n-Xv/ETH adaptation functions (Sn-X-L/ETH_A; n = 3, 4)

11.1.2.1 LCAS-capable VC-n-Xv/ETH adaptation source function (Sn-X-L/ETH_A_So)

This function maps ETH_CI information onto an Sn-X-L_AI signal (n = 3 or 4).

Data at the Sn-X-L_AP is a VC-n-X (n = 3 or 4), having a payload as described in ITU-T Rec. G.707/Y.1322, but with indeterminate POH bytes: J1, B3, G1.

Symbol

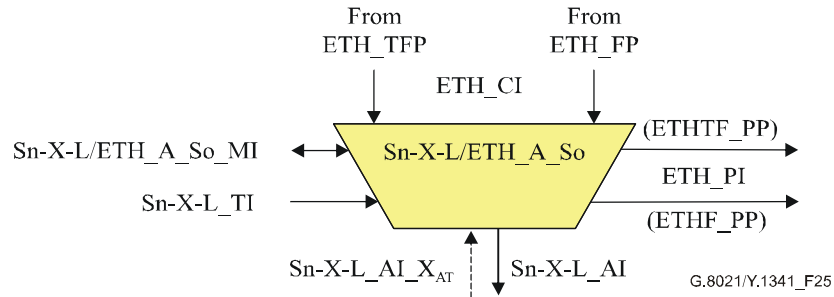

Figure 25/G.8021/Y.1341 – Sn-X-L/ETH_A_So symbol

Interfaces

Table 7/G.8021/Y.1341 – Sn-X-L/ETH_A_So interfaces

Inputs	Outputs
ETH_TFP: ETH_CI_Data	Sn-X-L_AP: Sn-X-L_AI_Data Sn-X-L_AI_Clock Sn-X-L_AI_FrameStart
ETH_FP: ETH_CI_Data ETH_CI_SSF	ETHF_PP: ETH_PI_Data
Sn-X-L_AP: Sn-X-L_AI_XAT	ETHTF_PP: ETH_PI_Data
Sn-X-L_TI: Sn-X-L_TI_Clock Sn-X-L_TI_FrameStart	
Sn-X-L/ETH_A_So_MI: Sn-X-L/ETH_A_So_MI_CSFEnable	

Processes

A process diagram of this function is shown in Figure 26.

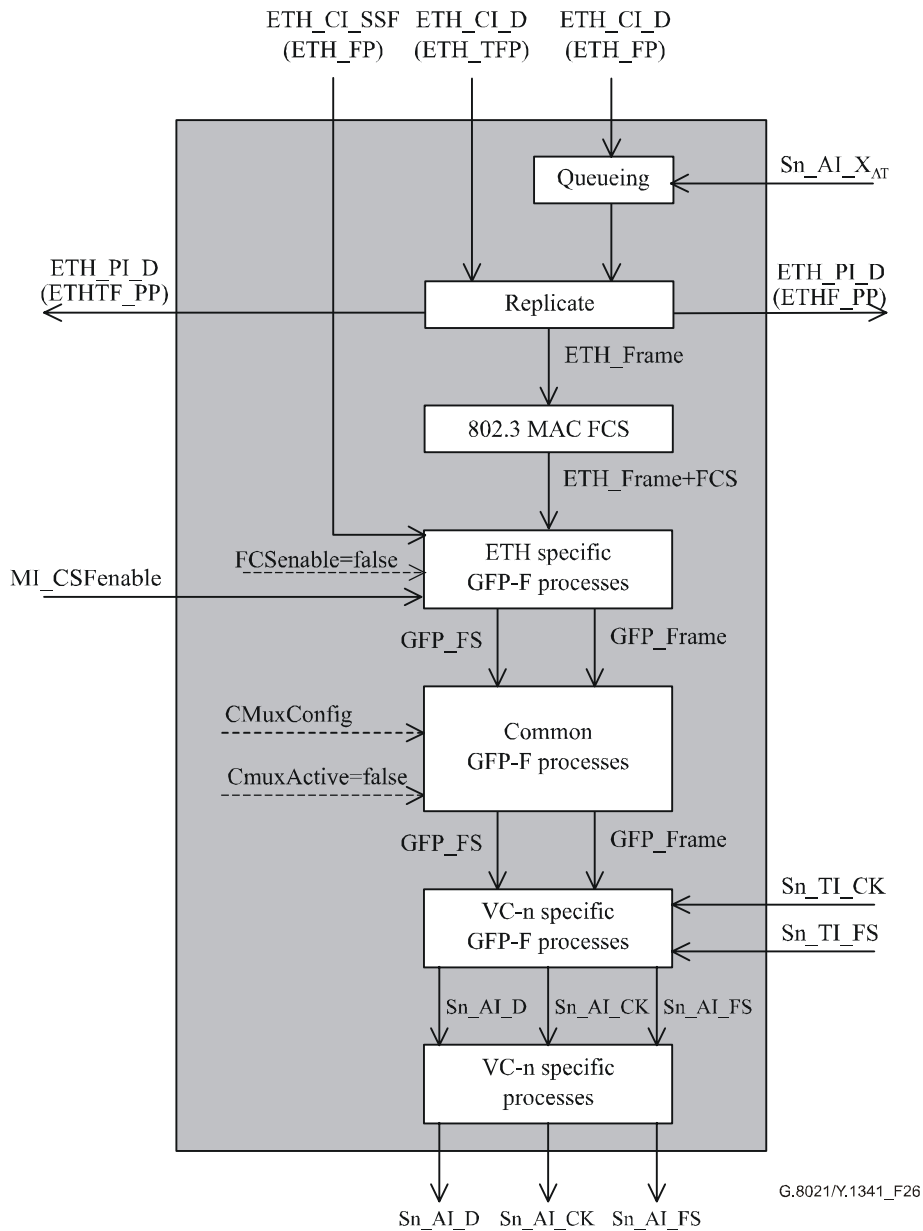

Figure 26/G.8021/Y.1341 – Sn-X-L/ETH_A_So process diagram

See 11.1.1.1 for a description of Sn-X-L/ETH_A processes.

Defects

None.

Consequent actions

None.

Defect correlations

None.

Performance monitoring

For further study.

11.1.2.2 LCAS-capable VC-n-Xv/ETH adaptation sink function (Sn-X-L/ETH_A_Sk)

This function extracts ETH_CI information from a VC-n-Xv server signal (n = 3 or 4), delivering ETH_CI to ETH_TFP and ETH_FP.

Data at the Sn-X-L_AP is a VC-n-Xv (n = 3 or 4), having a payload as described in ITU-T Rec. G.707/Y.1322.

Symbol

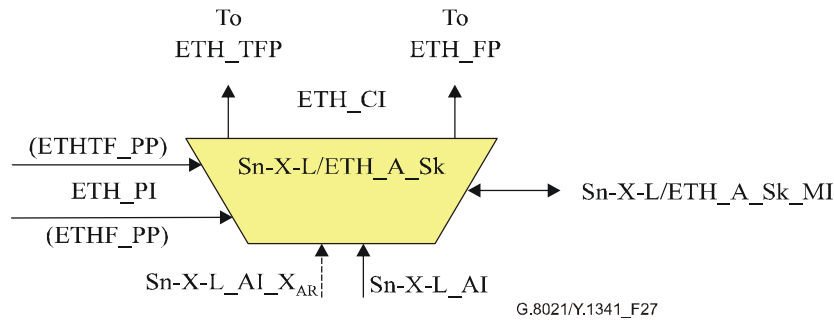

Figure 27/G.8021/Y.1341 – Sn-X-L/ETH_A_Sk symbol

Interfaces

Table 8/G.8021/Y.1341 – Sn-X-L/ETH_A_Sk interfaces

Inputs	Outputs
Sn-X-L_AP: Sn-X-L_AI_Data Sn-X-L_AI_Clock Sn-X-L_AI_FrameStart Sn-X-L_AI_TSF Sn-X-L_AI_XAR ETHF_PP: ETH_PI_Data ETHTF_PP: ETH_PI_Data Sn-X-L/ETH_A_Sk_MI: Sn-X-L/ETH_A_Sk_MI_FilterConfig Sn-X-L/ETH_A_Sk_MI_CSF_Reported	ETH_TFP: ETH_CI_Data ETH_CI_SSF ETH_FP: ETH_CI_Data ETH_CI_SSF Sn-X-L/ETH_A_Sk_MI: Sn-X-L/ETH_A_Sk_MI_AcSL Sn-X-L/ETH_A_Sk_MI_AcEXI Sn-X-L/ETH_A_Sk_MI_AcUPI Sn-X-L/ETH_A_Sk_MI_cPLM Sn-X-L/ETH_A_Sk_MI_cLFD Sn-X-L/ETH_A_Sk_MI_cUPM Sn-X-L/ETH_A_Sk_MI_cEXM Sn-X-L/ETH_A_Sk_MI_cCSF Sn-X-L/ETH_A_Sk_MI_pFCSError

Processes

See process diagram and process description in 11.1.1.2. The additional Sn-X-L_AI_XAR interface is not connected to any of the internal processes.

Defects

dPLM – See 6.2.4.2/G.806.

dLFD – See 6.2.5.2/G.806.

dUPM – See 6.2.4.3/G.806.

dEXM – See 6.2.4.4/G.806.

Consequent actions

The function shall perform the following consequent actions:

aSSF ← AI_TSF or dPLM or dLFD or dUPM or dEXM or dCSF

NOTE 1 – XAR = 0 results in AI_TSF being asserted, so there is no need to include it as additional contributor to aSSF.

Defect correlations

The function shall perform the following defect correlations to determine the most probable fault cause (see 6.4/G.806). This fault cause shall be reported to the EMF.

cPLM ← dPLM and (not AI_TSF);

cLFD ← dLFD and (not dPLM) and (not AI_TSF);

cUPM ← dUPM and (not dPLM) and (not dLFD) and (not AI_TSF);

cEXM ← dEXM and (not dUPM) and (not dPLM) and (not dLFD) and (not AI_TSF);

cCSF per 8.5.4.1.2/G.806.

Performance monitoring

The function shall perform the following performance monitoring primitives processing. The performance monitoring primitives shall be reported to the EMF.

pFCSError: count of FrameCheckSequenceErrors per second.

NOTE 2 – This primitive is calculated by the MAC frame check process.

11.1.3 VC-m/ETH adaptation functions (Sm/ETH_A; m = 11, 11-Xv, 12, 12-Xv, 2)

11.1.3.1 VC-m/ETH adaptation source function (Sm/ETH_A_So)

This function maps ETH_CI information onto a VC-m server signal (m = 11, 11-X, 12, 12-X, 2) and sources the Sm_AP signal.

Data at the Sm_AP is a VC-m (m = 11, 11-X, 12, 12-X, 2), having a payload as described in ITU-T Rec. G.707/Y.1322, but with indeterminate POH bytes: J2, V5[1-4], V5[8].

Symbol

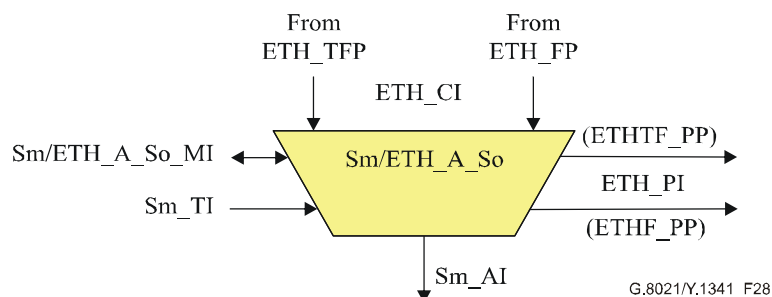

Figure 28/G.8021/Y.1341 – Sm/ETH_A_So symbol

Interfaces

Table 9/G.8021/Y.1341 – Sm/ETH_A_So interfaces

Inputs	Outputs
ETH_TFP: ETH_CI_Data	Sm_AP: Sm_AI_Data Sm_AI_ClocK Sm_AI_FrameStart
ETH_FP: ETH_CI_Data ETH_CI_SSF	ETHF_PP: ETH_PI_Data
Sm_AP: Sm_AI_X _{AT}	ETHTF_PP: ETH_PI_Data
Sm_TI: Sm_TI_ClocK Sm_TI_FrameStart	
Sm/ETH_A_So_MI: Sm/ETH_A_So_MI_CSFEnable	

Processes

A process diagram of this function is shown in Figure 29.

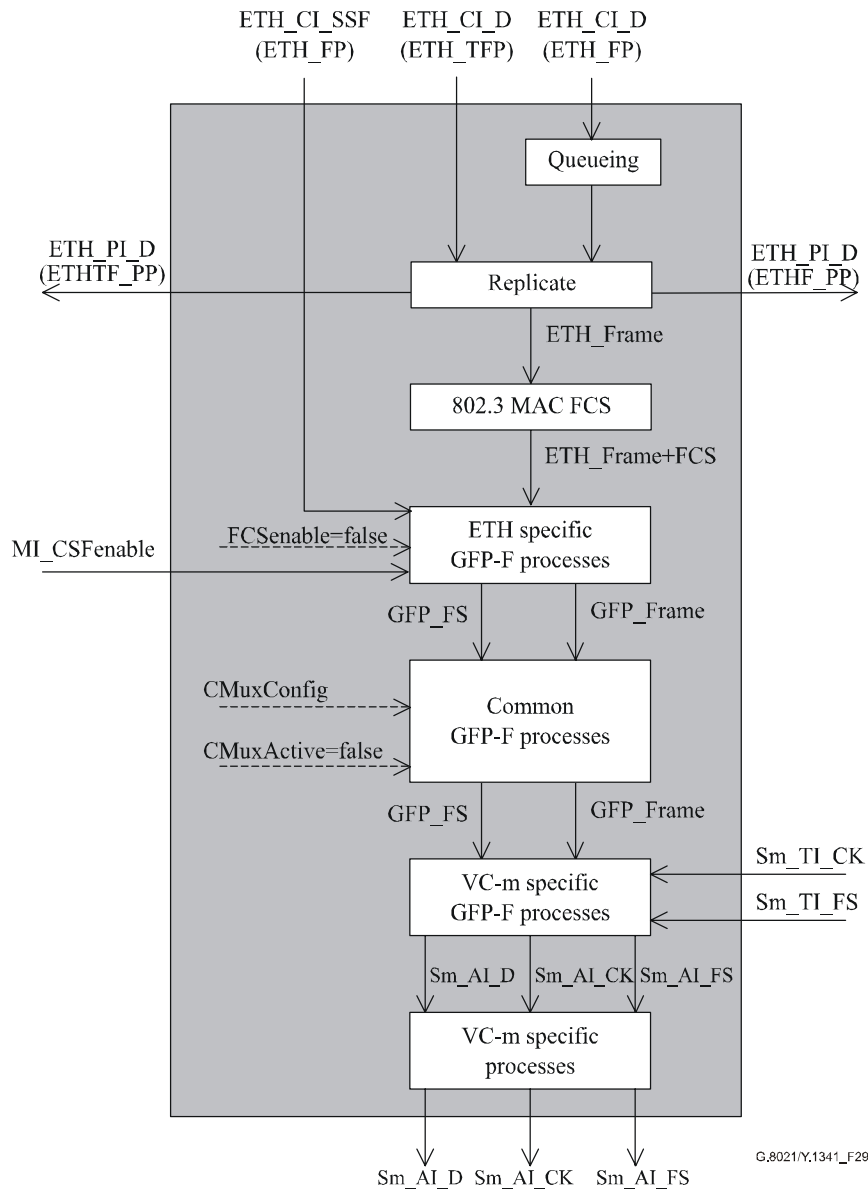

Figure 29/G.8021/Y.1341 – Sm/ETH_A_So process diagram

"Queuing" process:

See 8.2.

"Replicate" process:

See 8.4.

802.3 MAC FCS generation:

See 8.7.

Ethernet specific GFP-F source process:

See 8.5.4.1.1/G.806. GFP pFCS generation is disabled (FCSEnable=false). The UPI value for Frame-Mapped Ethernet shall be inserted (Table 6-3/G.7041/Y.1303). The Ethernet frames are inserted into the client payload information field of the GFP-F frames according to 7.1/G.7041/Y.1303.

Response to ETH_CI_SSF asserted is *for further study*.

Common GFP source process:

See 8.5.3.1/G.806. GFP channel multiplexing is not supported (CMuxActive=false).

VC-m specific GFP source process:

See 8.5.2.1/G.806. The GFP frames are mapped into the VC-m payload area according to 10.6/G.707/Y.1322.

VC-m specific source process:

V5[5-7] and K4[1]: Signal label information is derived directly from the adaptation function type. The value for "GFP mapping" in Table 9-13/G.707/Y.1322 is placed in the K4[1] Extended Signal Label field as described in 8.2.3.2/G.783.

K4[2]: For Sm/ETH_A_So with m = 11, 12, 2, the K4[2] bit is sourced as all-zeros.

NOTE 1 – For Sm/ETH_A_So with m = 11-X, 12-X, the K4[2] bit is undefined at the Sm-X_AP output of this function (as per clause 13/G.783).

NOTE 2 – For Sm/ETH_A_So with m = 11, 11-X, 12, 12-X, 2, the K4[3-8], V5[1-4] and V5[8] bits are undefined at the Sm-X_AP output of this function (as per clause 13/G.783).

Defects

None.

Consequent actions

None.

Defect correlations

None.

Performance monitoring

For further study.

11.1.3.2 VC-m/ETH adaptation sink function (Sm/ETH_A_Sk)

This function extracts ETH_CI information from the Sm_AI signal (m = 11, 11-X, 12, 12-X, 2), delivering ETH_CI to ETH_TFP and ETH_FP.

Data at the Sm_AP is as described in ITU-T Rec. G.707/Y.1322.

Symbol

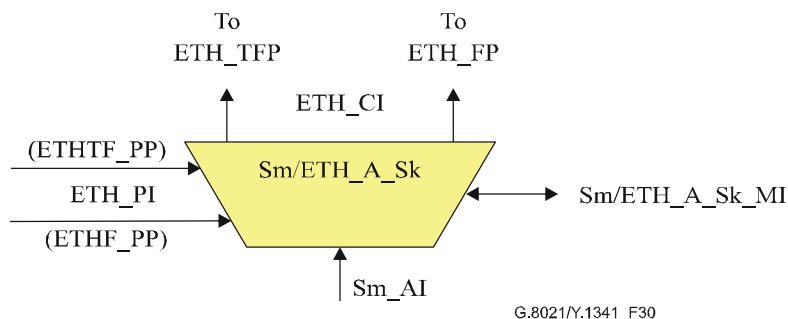

Figure 30/G.8021/Y.1341 – Sm/ETH_A_Sk symbol

Interfaces

Table 10/G.8021/Y.1341 – Sm/ETH_A_Sk interfaces

Inputs	Outputs
<p>Sm_AP: Sm_AI_Data Sm_AI_Clock Sm_AI_FrameStart Sm_AI_TSF</p> <p>ETHF_PP: ETH_PI_Data</p> <p>ETHTF_PP: ETH_PI_Data</p> <p>Sm/ETH_A_Sk_MI: Sm/ETH_A_Sk_MI_FilterConfig Sm/ETH_A_Sk_MI_CSF_Reported</p>	<p>ETH_TFP: ETH_CI_Data ETH_CI_SSF</p> <p>ETH_FP: ETH_CI_Data ETH_CI_SSF</p> <p>Sm/ETH_A_Sk_MI: Sm/ETH_A_Sk_MI_AcSL Sm/ETH_A_Sk_MI_AcEXI Sm/ETH_A_Sk_MI_AcUPI Sm/ETH_A_Sk_MI_cPLM Sm/ETH_A_Sk_MI_cLFD Sm/ETH_A_Sk_MI_cUPM Sm/ETH_A_Sk_MI_cEXM Sm/ETH_A_Sk_MI_cCSF Sm/ETH_A_Sk_MI_pFCSError</p>

Processes

A process diagram of this function is shown in Figure 31.

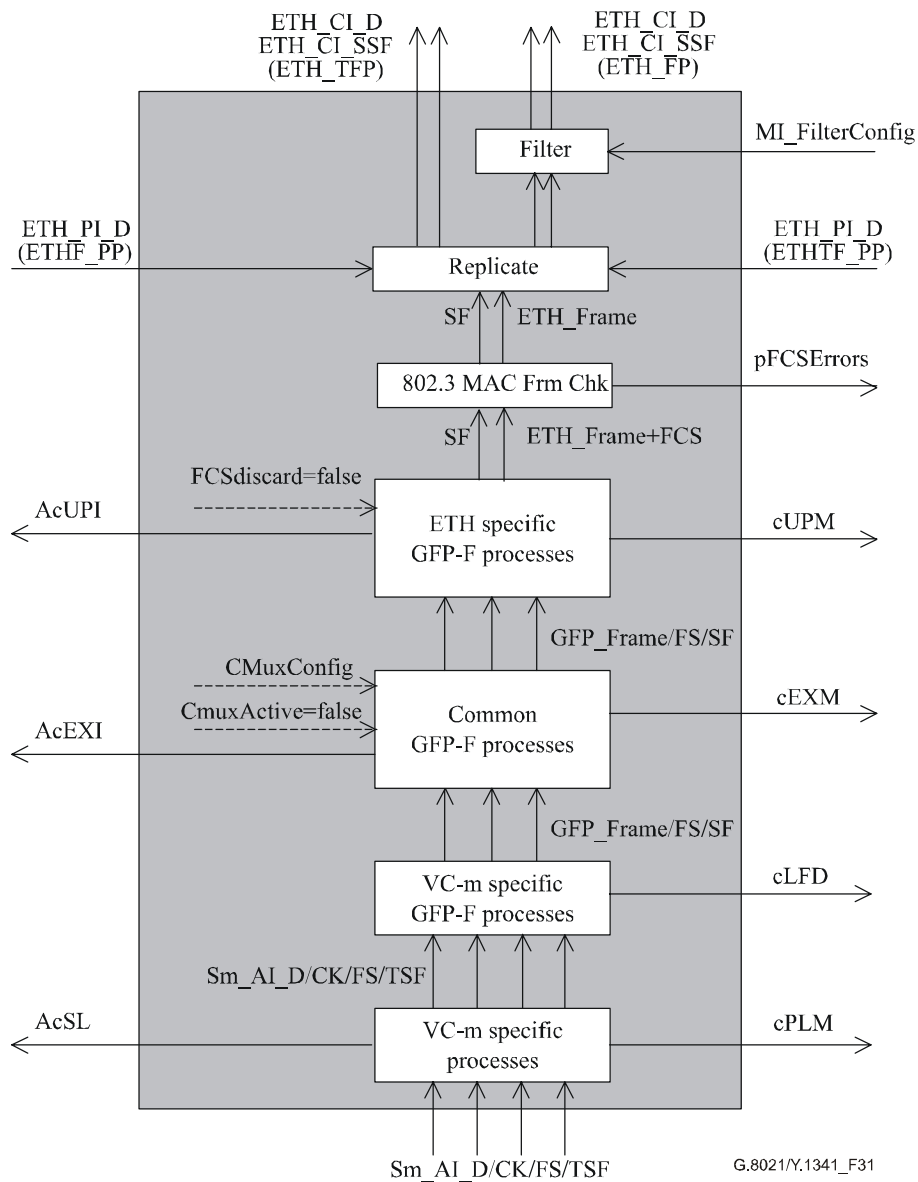

Figure 31/G.8021/Y.1341 – Sm/ETH_A_Sk process diagram

"Filter" process:

See 8.3.

"Replicate" process:

See 8.4.

"802.3 MAC Frame Check" process:

See 8.7.

Ethernet specific GFP-F sink process:

See 8.5.4.1.2/G.806. GFP pFCS checking, GFP p_FCSError, p_FDis are not supported (FCSdiscard=false). The UPI value for Frame-Mapped Ethernet shall be expected (Table 6-3/G.7041/Y.1303). The Ethernet frames are extracted from the client payload information field of the GFP-F frames according to 7.1/G.7041/Y.1303.

Common GFP sink process:

See 8.5.3.1/G.806. GFP channel multiplexing is not supported (CMuxActive=false).

VC-m specific GFP sink process:

See 8.5.2.1/G.806. The GFP frames are demapped from the VC-m payload area according to 10.6/G.707/Y.1322.

VC-m specific sink process:

V5[5-7] and K4[1]: The signal label is recovered from the extended signal label position as described in 8.2.3.2/G.783 and 6.2.4.2/G.806. The signal label for "GFP mapping" in Table 9-13/G.707/Y.1322 shall be expected. The accepted value of the signal label is also available at the Sm/ETH_A_Sk_MP.

Defects

dPLM – See 6.2.4.2/G.806.

dLFD – See 6.2.5.2/G.806.

dUPM – See 6.2.4.3/G.806.

dEXM – See 6.2.4.4/G.806.

Consequent actions

The function shall perform the following consequent actions:

aSSF ← AI_TSF or dPLM or dLFD or dUPM or dEXM or dCSF

Defect correlations

The function shall perform the following defect correlations to determine the most probable fault cause (see 6.4/G.806). This fault cause shall be reported to the EMF.

cPLM ← dPLM and (not AI_TSF);

cLFD ← dLFD and (not dPLM) and (not AI_TSF);

cUPM ← dUPM and (not dPLM) and (not dLFD) and (not AI_TSF);

cEXM ← dEXM and (not dUPM) and (not dPLM) and (not dLFD) and (not AI_TSF);

cCSF per 8.5.4.1.2/G.806.

Performance monitoring

The function shall perform the following performance monitoring primitives processing. The performance monitoring primitives shall be reported to the EMF.

pFCSError: count of FrameCheckSequenceErrors per second.

NOTE – This primitive is calculated by the MAC frame check process.

11.1.4 LCAS-capable VC-m-Xv/ETH adaptation functions (Sm-X-L/ETH_A; m = 11 or 12)

11.1.4.1 LCAS-capable VC-m-Xv/ETH adaptation source function (Sm-X-L/ETH_A_So)

This function maps ETH_CI information onto an Sm-X-L_AI signal (m = 11 or 12).

Data at the Sm-X-L_AP is a VC-m-X (m = 11 or 12), having a payload as described in ITU-T Rec. G.707/Y.1322, but with indeterminate POH bytes: J2, V5[1-4], V5[8].

Symbol

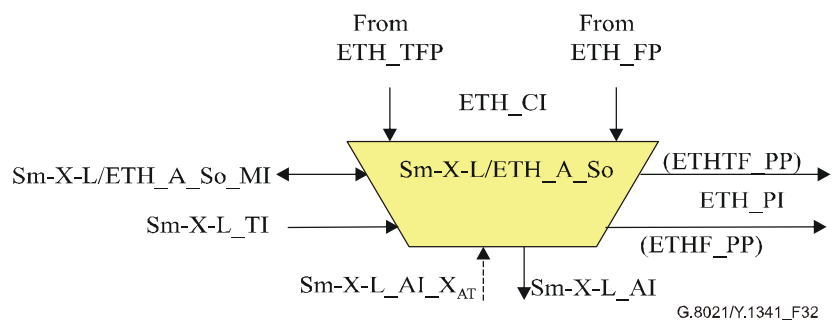

Figure 32/G.8021/Y.1341 – Sm-X-L/ETH_A_So symbol

Interfaces

Table 11/G.8021/Y.1341 – Sm-X-L/ETH_A_So interfaces

Inputs	Outputs
ETH_TFP: ETH_CI_Data ETH_FP: ETH_CI_Data ETH_CI_SSF Sm-X-L_AP: Sm-X-L_AI_XAT Sm_TI: Sm_TI_Clock Sm_TI_FrameStart Sm-X-L/ETH_A_So_MI: Sm-X-L/ETH_A_So_MI_CSFEnable	Sm-X-L_AP: Sm-X-L_AI_Data Sm-X-L_AI_Clock Sm-X-L_AI_FrameStart ETHF_PP: ETH_PI_Data ETHTF_PP: ETH_PI_Data

Processes

A process diagram of this function is shown in Figure 33.

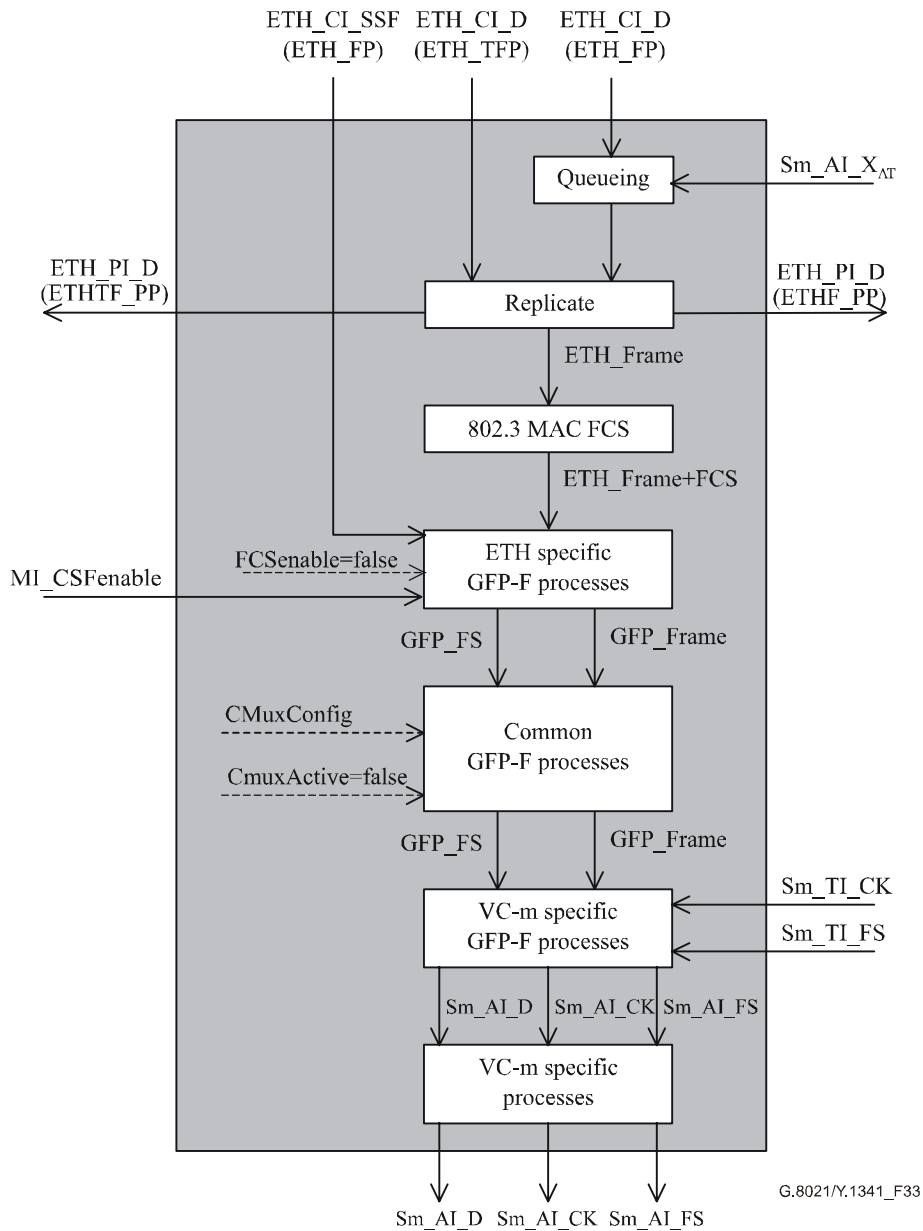

Figure 33/G.8021/Y.1341 – Sm-X-L/ETH_A_So process diagram

See 11.1.3.1 for a description of Sm-X-L/ETH_A processes.

Defects

None.

Consequent actions

None.

Defect correlations

None.

Performance monitoring

For further study.

11.1.4.2 LCAS-capable VC-m-Xv/ETH adaptation sink function (Sm-X-L/ETH_A_Sk)

This function extracts ETH_CI information from the Sm-X-L_AI signal (m = 11 or 12), delivering ETH_CI to ETH_TFP and ETH_FP.

Data at the Sm_AP is as described in ITU-T Rec. G.707/Y.1322.

Symbol

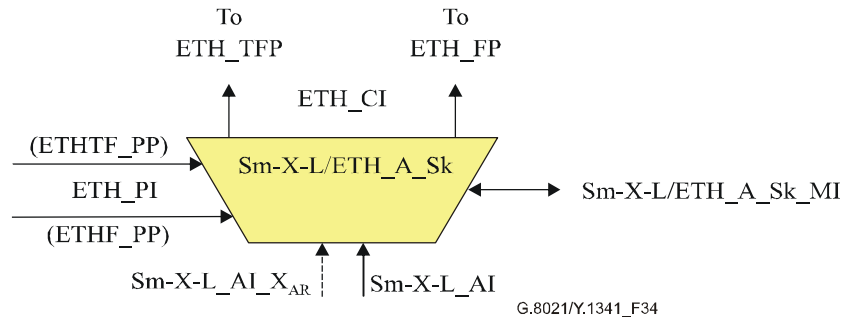

Figure 34/G.8021/Y.1341 – Sm-X-L/ETH_A_Sk symbol

Interfaces

Table 12/G.8021/Y.1341 – Sm-X-L/ETH_A_Sk interfaces

Inputs	Outputs
Sm-X-L_AP: Sm-X-L_AI_Data Sm-X-L_AI_ClocK Sm-X-L_AI_FrameStart Sm-X-L_AI_TSF Sm-X-L_AI_XAR	ETH_TFP: ETH_CI_Data ETH_CI_SSF
ETHF_PP: ETH_PI_Data	ETH_FP: ETH_CI_Data ETH_CI_SSF
ETHTF_PP: ETH_PI_Data	Sm-X-L/ETH_A_Sk_MI: Sm-X-L/ETH_A_Sk_MI_AcSL Sm-X-L/ETH_A_Sk_MI_AcEXI Sm-X-L/ETH_A_Sk_MI_AcUPI Sm-X-L/ETH_A_Sk_MI_cPLM Sm-X-L/ETH_A_Sk_MI_cLFD Sm-X-L/ETH_A_Sk_MI_cUPM Sm-X-L/ETH_A_Sk_MI_cEXM Sm-X-L/ETH_A_Sk_MI_cCSF Sm-X-L/ETH_A_Sk_MI_pFCSError
Sm-X-L/ETH_A_Sk_MI: Sm-X-L/ETH_A_Sk_MI_FilterConfig Sm-X-L/ETH_A_Sk_MI_CSF_Reported	

Processes

See process diagram and process description in 11.1.1.2. The additional Sm-X-L_AI_XAR interface is not connected to any of the internal processes.

Defects

dPLM – See 6.2.4.2/G.806.

dLFD – See 6.2.5.2/G.806.

dUPM – See 6.2.4.3/G.806.

dEXM – See 6.2.4.4/G.806.

Consequent actions

The function shall perform the following consequent actions:

aSSF ← AI_TSF or dPLM or dLFD or dUPM or dEXM or dCSF

NOTE 1 – XAR = 0 results in AI_TSF being asserted, so there is no need to include it as additional contributor to aSSF.

Defect correlations

The function shall perform the following defect correlations to determine the most probable fault cause (see 6.4/G.806). This fault cause shall be reported to the EMF.

cPLM ← dPLM and (not AI_TSF);

cLFD ← dLFD and (not dPLM) and (not AI_TSF);

cUPM ← dUPM and (not dPLM) and (not dLFD) and (not AI_TSF);

cEXM ← dEXM and (not dUPM) and (not dPLM) and (not dLFD) and (not AI_TSF);

cCSF per 8.5.4.1.2/G.806.

Performance monitoring

The function shall perform the following performance monitoring primitives processing. The performance monitoring primitives shall be reported to the EMF.

pFCSError: count of FrameCheckSequenceErrors per second.

NOTE 2 – This primitive is calculated by the MAC FCS process.

11.2 SDH/ETC adaptation functions (S4-X/ETC3_A)

This covers GFP-T-based mapping of Gigabit Ethernet codewords into VC-4-Xv.

For further study.

11.3 S4-64c/ETH-w adaptation functions

This covers 64B/66B-encoded mapping of Ethernet frames into VC-4-64c.

For further study.

11.4 PDH/ETH adaptation functions (P/ETH_A)

For further study.

11.5 OTH/ETH adaptation functions (O/ETH_A)

For further study.

11.6 MPLS/ETH adaptation functions (MPLS/ETH_A)

For further study.

11.7 ATM VC/ETH adaptation functions (VC/ETH_A)

For further study.

11.8 RPR/ETH adaptation functions (RPR/ETH_A)

For further study.

Appendix I

Applications and functional diagrams

Figure I.1 presents the set of atomic functions associated with the Ethernet signal transport, shown in several example applications.

- Ethernet UNI/NNI interface port on EoT equipment.
- Ethernet over SDH NNI interface port on EoT equipment.
- Ethernet UNI interface port supporting multiplexed access on EoT equipment.

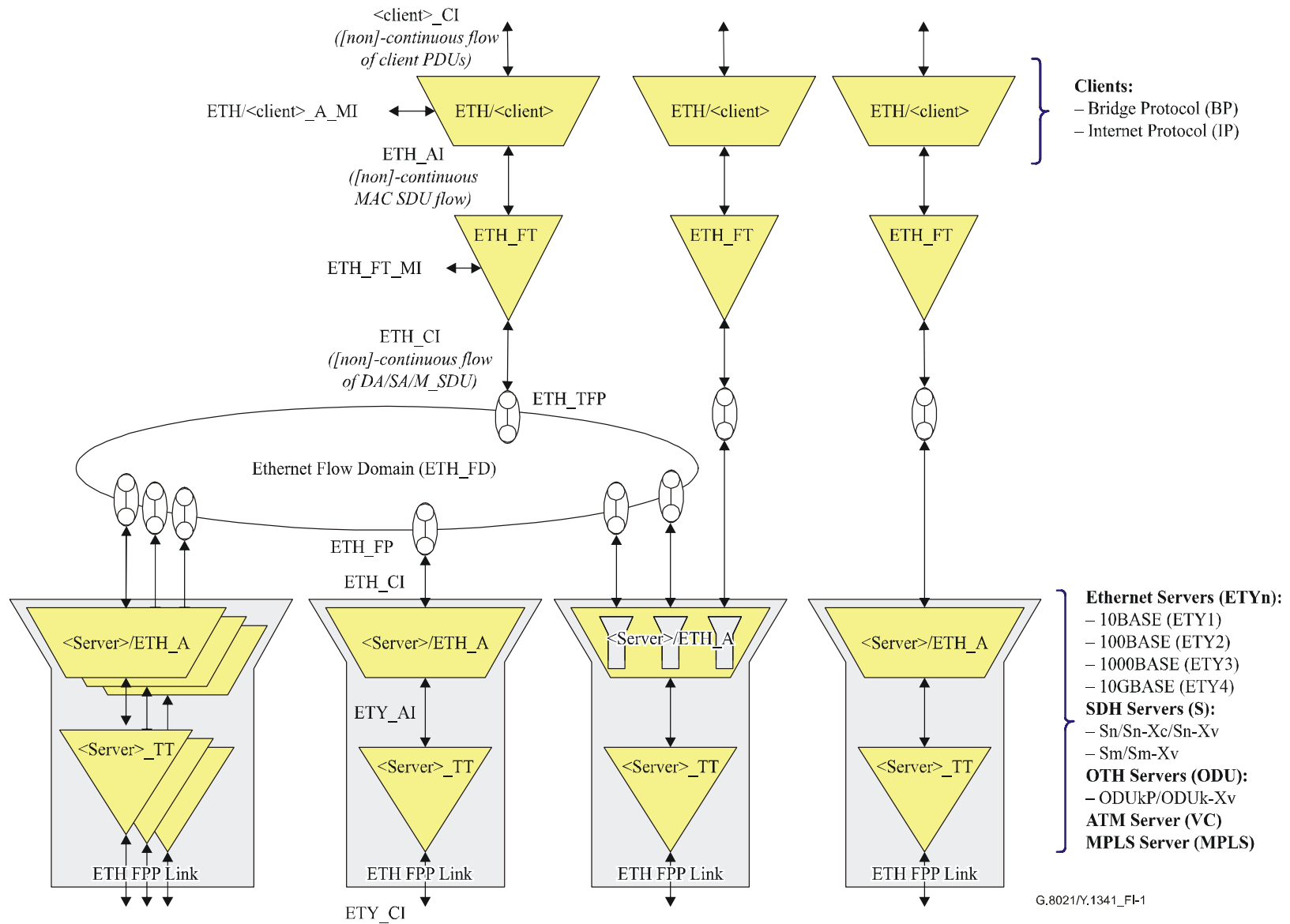

Figure I.1/G.8021/Y.1341 – Ethernet atomic functions in some possible application

ITU-T Y-SERIES RECOMMENDATIONS
**GLOBAL INFORMATION INFRASTRUCTURE, INTERNET PROTOCOL ASPECTS AND NEXT
GENERATION NETWORKS**

GLOBAL INFORMATION INFRASTRUCTURE	
General	Y.100–Y.199
Services, applications and middleware	Y.200–Y.299
Network aspects	Y.300–Y.399
Interfaces and protocols	Y.400–Y.499
Numbering, addressing and naming	Y.500–Y.599
Operation, administration and maintenance	Y.600–Y.699
Security	Y.700–Y.799
Performances	Y.800–Y.899
INTERNET PROTOCOL ASPECTS	
General	Y.1000–Y.1099
Services and applications	Y.1100–Y.1199
Architecture, access, network capabilities and resource management	Y.1200–Y.1299
Transport	Y.1300–Y.1399
Interworking	Y.1400–Y.1499
Quality of service and network performance	Y.1500–Y.1599
Signalling	Y.1600–Y.1699
Operation, administration and maintenance	Y.1700–Y.1799
Charging	Y.1800–Y.1899
NEXT GENERATION NETWORKS	
Frameworks and functional architecture models	Y.2000–Y.2099
Quality of Service and performance	Y.2100–Y.2199
Service aspects: Service capabilities and service architecture	Y.2200–Y.2249
Service aspects: Interoperability of services and networks in NGN	Y.2250–Y.2299
Numbering, naming and addressing	Y.2300–Y.2399
Network management	Y.2400–Y.2499
Network control architectures and protocols	Y.2500–Y.2599
Security	Y.2700–Y.2799
Generalized mobility	Y.2800–Y.2899

For further details, please refer to the list of ITU-T Recommendations.

SERIES OF ITU-T RECOMMENDATIONS

Series A	Organization of the work of ITU-T
Series D	General tariff principles
Series E	Overall network operation, telephone service, service operation and human factors
Series F	Non-telephone telecommunication services
Series G	Transmission systems and media, digital systems and networks
Series H	Audiovisual and multimedia systems
Series I	Integrated services digital network
Series J	Cable networks and transmission of television, sound programme and other multimedia signals
Series K	Protection against interference
Series L	Construction, installation and protection of cables and other elements of outside plant
Series M	TMN and network maintenance: international transmission systems, telephone circuits, telegraphy, facsimile and leased circuits
Series N	Maintenance: international sound programme and television transmission circuits
Series O	Specifications of measuring equipment
Series P	Telephone transmission quality, telephone installations, local line networks
Series Q	Switching and signalling
Series R	Telegraph transmission
Series S	Telegraph services terminal equipment
Series T	Terminals for telematic services
Series U	Telegraph switching
Series V	Data communication over the telephone network
Series X	Data networks and open system communications
Series Y	Global information infrastructure, Internet protocol aspects and Next Generation Networks
Series Z	Languages and general software aspects for telecommunication systems