

Recommendation

ITU-T G.8152.2/Y.1375.2 (2021) Amd. 1 (11/2022)

SERIES G: Transmission systems and media, digital systems and networks

Packet over Transport aspects – MPLS over Transport aspects

SERIES Y: Global information infrastructure, Internet protocol aspects, next-generation networks, Internet of Things and smart cities

Internet protocol aspects – Transport

**Resilience information/data models for the
MPLS-TP network element
Amendment 1**



ITU-T G-SERIES RECOMMENDATIONS
TRANSMISSION SYSTEMS AND MEDIA, DIGITAL SYSTEMS AND NETWORKS

INTERNATIONAL TELEPHONE CONNECTIONS AND CIRCUITS	G.100–G.199
GENERAL CHARACTERISTICS COMMON TO ALL ANALOGUE CARRIER-TRANSMISSION SYSTEMS	G.200–G.299
INDIVIDUAL CHARACTERISTICS OF INTERNATIONAL CARRIER TELEPHONE SYSTEMS ON METALLIC LINES	G.300–G.399
GENERAL CHARACTERISTICS OF INTERNATIONAL CARRIER TELEPHONE SYSTEMS ON RADIO-RELAY OR SATELLITE LINKS AND INTERCONNECTION WITH METALLIC LINES	G.400–G.449
COORDINATION OF RADIOTELEPHONY AND LINE TELEPHONY	G.450–G.499
TRANSMISSION MEDIA AND OPTICAL SYSTEMS CHARACTERISTICS	G.600–G.699
DIGITAL TERMINAL EQUIPMENTS	G.700–G.799
DIGITAL NETWORKS	G.800–G.899
DIGITAL SECTIONS AND DIGITAL LINE SYSTEM	G.900–G.999
MULTIMEDIA QUALITY OF SERVICE AND PERFORMANCE – GENERIC AND USER-RELATED ASPECTS	G.1000–G.1999
TRANSMISSION MEDIA CHARACTERISTICS	G.6000–G.6999
DATA OVER TRANSPORT – GENERIC ASPECTS	G.7000–G.7999
PACKET OVER TRANSPORT ASPECTS	G.8000–G.8999
Ethernet over Transport aspects	G.8000–G.8099
MPLS over Transport aspects	G.8100–G.8199
Synchronization, quality and availability targets	G.8200–G.8299
Mobile network transport aspects	G.8300–G.8399
Service Management	G.8600–G.8699
ACCESS NETWORKS	G.9000–G.9999

For further details, please refer to the list of ITU-T Recommendations.

Recommendation ITU-T G.8152.2/Y.1375.2

Resilience information/data models for the MPLS TP network element

Amendment 1

Summary

Recommendation ITU-T G.8152.2/Y.1375.2 specifies resilience management information and data models for a multi-protocol label switching-transport profile (MPLS-TP) network element (NE) as specified in Recommendations ITU-T G.8131 and ITU-T G.8132. The information model is interface protocol neutral and specified using the unified modelling language (UML). The information model in Recommendation G.8152.2/Y.1375.2 is derived through pruning and refactoring from the Recommendation ITU-T G.7711/Y.1702 core information model and Recommendation ITU-T G.8152/Y.1375 foundation MPLS-TP NE information model. The data models are interface protocol specific and translated from the information model with the assistance of automated translation tooling. The specific data models considered in Recommendation ITU-T G.8152.2/Y.1375.2 include, but are not limited to, those of the yet another next generation (YANG) type.

Amendment 1 updates the UML model and data model for MPLS-TP linear protection.

History

Edition	Recommendation	Approval	Study Group	Unique ID*
1.0	ITU-T G.8152.2/Y.1375.2	2021-01-13	15	11.1002/1000/14560
1.1	ITU-T G.8152.2/Y.1375.2 (2021) Amd. 1	2022-11-29	15	11.1002/1000/15170

Keywords

Data model YANG, information model, MPLS-TP, resilience, UML.

* To access the Recommendation, type the URL <http://handle.itu.int/> in the address field of your web browser, followed by the Recommendation's unique ID. For example, <http://handle.itu.int/11.1002/1000/11830-en>.

FOREWORD

The International Telecommunication Union (ITU) is the United Nations specialized agency in the field of telecommunications, information and communication technologies (ICTs). The ITU Telecommunication Standardization Sector (ITU-T) is a permanent organ of ITU. ITU-T is responsible for studying technical, operating and tariff questions and issuing Recommendations on them with a view to standardizing telecommunications on a worldwide basis.

The World Telecommunication Standardization Assembly (WTSA), which meets every four years, establishes the topics for study by the ITU-T study groups which, in turn, produce Recommendations on these topics.

The approval of ITU-T Recommendations is covered by the procedure laid down in WTSA Resolution 1.

In some areas of information technology which fall within ITU-T's purview, the necessary standards are prepared on a collaborative basis with ISO and IEC.

NOTE

In this Recommendation, the expression "Administration" is used for conciseness to indicate both a telecommunication administration and a recognized operating agency.

Compliance with this Recommendation is voluntary. However, the Recommendation may contain certain mandatory provisions (to ensure, e.g., interoperability or applicability) and compliance with the Recommendation is achieved when all of these mandatory provisions are met. The words "shall" or some other obligatory language such as "must" and the negative equivalents are used to express requirements. The use of such words does not suggest that compliance with the Recommendation is required of any party.

INTELLECTUAL PROPERTY RIGHTS

ITU draws attention to the possibility that the practice or implementation of this Recommendation may involve the use of a claimed Intellectual Property Right. ITU takes no position concerning the evidence, validity or applicability of claimed Intellectual Property Rights, whether asserted by ITU members or others outside of the Recommendation development process.

As of the date of approval of this Recommendation, ITU had not received notice of intellectual property, protected by patents/software copyrights, which may be required to implement this Recommendation. However, implementers are cautioned that this may not represent the latest information and are therefore strongly urged to consult the appropriate ITU-T databases available via the ITU-T website at <http://www.itu.int/ITU-T/ipr/>.

© ITU 2023

All rights reserved. No part of this publication may be reproduced, by any means whatsoever, without the prior written permission of ITU.

Table of Contents

	Page
1 Scope	1
2 References.....	1
3 Definitions	2
3.1 Terms defined elsewhere	2
3.2 Terms defined in this Recommendation	2
4 Abbreviations and acronyms	3
5 Conventions	3
5.1 Information modelling conventions	3
6 MPLS-TP resilience functions.....	4
6.1 Linear protection functions.....	4
6.2 Ring protection functions.....	4
7 MPLS-TP resilience information model.....	4
7.1 MPLS-TP linear protection information model.....	5
7.2 MPLS-TP shared ring protection information model	16
7.3 UML model files	23
8 MPLS-TP resilience data models.....	24
8.1 MPLS-TP YANG data model.....	24
Annex A – MSRP information model	25
A.1 Wrapping.....	26
A.2 Steering	30
A.3 Short-wrapping	32
Appendix I – Linear protection examples	36
I.1 1+1/1:1 Cases.....	36
Appendix II – Examples of using the IETF MPLS static lsp models to support MPLS-TP linear protection models.....	39
II.1 JSON examples.....	39
II.2 MPLS-TP trail protection examples.....	39
II.3 MPLS-TP sub-network protection (SNC/S) examples	42
Appendix III – Relationship between the MPLS-TP linear protection and the reverse- engineered IETF MPLS static UML model.....	46
Bibliography	47

Recommendation ITU-T G.8152.2/Y.1375.2

Resilience information/data models for the MPLS-TP network element

Amendment 1

Editorial note: This is a complete-text publication. Modifications introduced by this amendment are shown in revision marks relative to Recommendation ITU-T G.8152.2/Y.1375.2 (2021).

1 Scope

This Recommendation specifies resilience information models and data models for a multi-protocol label switching-transport profile (MPLS-TP) transport network element (NE) to support specific interface protocols and specific management and control functions. The information models are interface protocol neutral and derived through pruning and refactoring from the ITU-T G.7711 core information model and ITU-T G.8152 foundation MPLS-TP NE information model. The data models are interface protocol specific and translated from these information models. The specific data models considered in this Recommendation include, but are not limited to, those of the yet another next generation (YANG) type. The specific management and control functions for resilience covered by this Recommendation include ITU-T G.8131 MPLS-TP linear protection switching and ITU-T G.8132 MPLS-TP shared ring protection (MSRP) switching.

The YANG modules of this Recommendation aim to be compatible with and when necessary extend the relevant generic ones developed by the Internet Engineering Task Force (IETF) for the ITU-T G.8131 and ITU-T G.8132 resilience functions.

2 References

The following ITU-T Recommendations and other references contain provisions which, through reference in this text, constitute provisions of this Recommendation. At the time of publication, the editions indicated were valid. All Recommendations and other references are subject to revision; users of this Recommendation are therefore encouraged to investigate the possibility of applying the most recent edition of the Recommendations and other references listed below. A list of the currently valid ITU-T Recommendations is regularly published. The reference to a document within this Recommendation does not give it, as a stand-alone document, the status of a Recommendation.

- [ITU-T G.780] Recommendation ITU-T G.780/Y.1351 (2010), *Terms and definitions for synchronous digital hierarchy (SDH) networks.*
- [ITU-T G.806] Recommendation ITU-T G.806 (2012), *Characteristics of transport equipment – Description methodology and generic functionality.*
- [ITU-T G.808] Recommendation ITU-T G.808 (2016), *Terms and definitions for network protection and restoration.*
- [ITU-T G.7711] Recommendation ITU-T G.7711/Y.1702 (2018), *Generic protocol-neutral information model for transport resources.*
- [ITU-T G.8131] Recommendation ITU-T G.8131/Y.1382 (2014), *Linear protection switching for MPLS transport profile.*
- [ITU-T G.8132] Recommendation ITU-T G.8132/Y.1383 (2017), *MPLS-TP shared ring protection.*
- [ITU-T G.8152] Recommendation ITU-T G.8152/Y.1735 (2018), *Protocol-neutral management information model for the MPLS-TP network element.*

[\[IETF RFC 6991\]](#) [IETF RFC 6691 \(2013\), *Common YANG Data Types*.](#)

[IETF RFC 7950] IETF RFC 7950 (2016), *The YANG 1.1 data modeling language*.

~~[\[IETF RFC 8227\]](#) [IETF RFC 8227 \(2017\), *MPLS-TP shared-ring protection \(MSRP\) mechanism for ring topology*.](#)~~

[IETF RFC 8340] IETF RFC 8340 (2018), *YANG tree diagrams*.

[IETF RFC 8342] IETF RFC 8342 (2018), *Network management datastore architecture (NMDA)*.

~~[\[IETF RFC 8227\]](#) [IETF RFC 8227 \(2017\), *MPLS-TP shared-ring protection \(MSRP\) mechanism for ring topology*.](#)~~

[\[IETF RFC 8531\]](#) [IETF RFC 8531 \(2019\), *Generic YANG Data Model for Connection-Oriented Operations, Administration, and Maintenance \(OAM\) Protocols*.](#)

3 Definitions

3.1 Terms defined elsewhere

This Recommendation uses the following terms defined elsewhere:

3.1.1 1+1 (protection) architecture: [ITU-T G.808]

3.1.2 1:n (protection) architecture ($n \geq 1$): [ITU-T G.808]

3.1.3 clear: [ITU-T G.808]

3.1.4 exercise signal: [ITU-T G.808]

3.1.5 forced switch: [ITU-T G.808]

3.1.6 hold-off time: [ITU-T G.808]

3.1.7 manual switch: [ITU-T G.808]

3.1.8 protection: [ITU-T G.808]

3.1.9 protection group: [ITU-T G.808]

3.1.10 server signal fail (SSF): [ITU-T G.806]

3.1.11 signal degrade (SD): [ITU-T G.806]

3.1.12 signal fail (SF): [ITU-T G.806]

3.1.13 steering: [ITU-T G.808]

3.1.14 switch: [ITU-T G.808]

3.1.15 unidirectional protection switching: [ITU-T G.780]

3.1.16 wait-to-restore time: [ITU-T G.808]

3.1.17 wrapping: [ITU-T G.808]

3.2 Terms defined in this Recommendation

None.

4 Abbreviations and acronyms

This Recommendation uses the following abbreviations and acronyms:

EXER	Exercise
FC	Forwarding Construct
FS	Forced Switch
LP	Layer Protocol
LP	Lockout of Protection
LSP	Label Switched Path
LTP	Logical Termination Point
<u>MA</u>	<u>Maintenance Association</u>
<u>MCS</u>	<u>Management and Control System</u>
<u>MD</u>	<u>Maintenance Domain</u>
<u>MEG</u>	<u>Maintenance Entity Group</u>
<u>MEP</u>	<u>Maintenance entity group End Point</u>
<u>MIP</u>	<u>Maintenance entity group Intermediate Point</u>
MPLS	Multi-Protocol Label Switching
MPLS-TP	Multi-Protocol Label Switching-Transport profile
MS	Manual Switch
MSRP	MPLS-TP Shared Ring Protection
MT	MPLS-TP
NE	Network Element
<u>NCM</u>	<u>Network Connection Monitoring</u>
<u>NHLFE</u>	<u>Next Hop Label Forwarding Entry</u>
OAM	Operations, Administration and Maintenance
SD	Signal Degrade
SF	Signal Fail
SNC/S	SNCP with Sublayer monitoring
SNCP	Subnetwork Connection Protection
SSF	Server Signal Fail
<u>TCM</u>	<u>Tandem Connection Monitoring</u>
UML	Unified Modelling Language
WTR	Wait-to-Restore
YANG	Yet Another Next Generation

5 Conventions

5.1 Information modelling conventions

See clause 5.1 of [ITU-T G.7711].

5.1.1 Unified modelling language modelling conventions

See clause 5.1 of [ITU-T G.7711].

5.1.2 Model Artefact Lifecycle Stereotypes conventions

See clause 5.2 of [ITU-T G.7711].

5.1.3 Forwarding entity terminology conventions

See clause 5.3 of [ITU-T G.7711].

5.1.4 Conditional package conventions

See clause 5.4 of [ITU-T G.7711].

5.1.5 Pictorial diagram conventions

See clause 5.5 of [ITU-T G.7711].

6 MPLS-TP resilience functions

This clause identifies the MPLS-TP Resilience functions that are modelled by the information model and data models of this Recommendation.

6.1 Linear protection functions

The MPLS-TP linear protection function is specified in [ITU-T G.8131]. The linear protection type characteristic can be of the types listed in Table 6-1.

Table 6-1 – MPLS-TP linear protection type

Protection type	Source
Unidirectional 1+1 SNC/S protection switching	[ITU-T G.8131]
Bidirectional 1+1 SNC/S protection switching	[ITU-T G.8131]
Bidirectional 1:1 SNC/S protection switching	[ITU-T G.8131]
MPLS-TP trail protection	[ITU-T G.8131]

6.2 Ring protection functions

The MPLS-TP ring protection function is specified in [ITU-T G.8132]. The ring protection type characteristic can be of the types listed in Table 6-2.

Table 6-2 – MPLS-TP ring protection type

Protection type	Source
Wrapping	[ITU-T G.8132]
Short wrapping	[ITU-T G.8132]
Steering	[ITU-T G.8132]

7 MPLS-TP resilience information model

This clause contains the unified modelling language (UML) information model of the MPLS-TP protection functions identified in clause 6. The information model is derived through pruning and refactoring the ITU-T G.7711 core information model and ITU-T G.8152 MPLS-TP base information model.

7.1 Required object classes and relations MPLS-TP linear protection information model

7.1.1 Linear protection Mapping between ITU-T G.8131, ITU-T G.8152 and ITU-T G.7711 for MPLS-TP Linear protection

Clause 6.1 of [ITU-T G.8131] describes the protection switching architecture for the MPLS-TP linear protection group, including unidirectional 1+1 subnetwork connection protection (SNCP) with sublayer monitoring (SNC/S) protection switching, bidirectional 1+1 SNC/S protection switching, and bidirectional 1:1 SNC/S protection switching. All these architectures can be modelled by using the same set of object classes, so unidirectional 1+1 SNC/S protection switching is chosen as an example to describe the MPLS-TP linear protection object classes. Annex E of [ITU-T G.7711] has the generic resilience model applicable to the linear protection switching schemes. Figure 7-1 and Table 7-1 shows the mapping between the ITU-T G.8131 functions, and the ITU-T G.7711 and the ITU-T G.8152 object classes for the MPLS-TP linear protection.

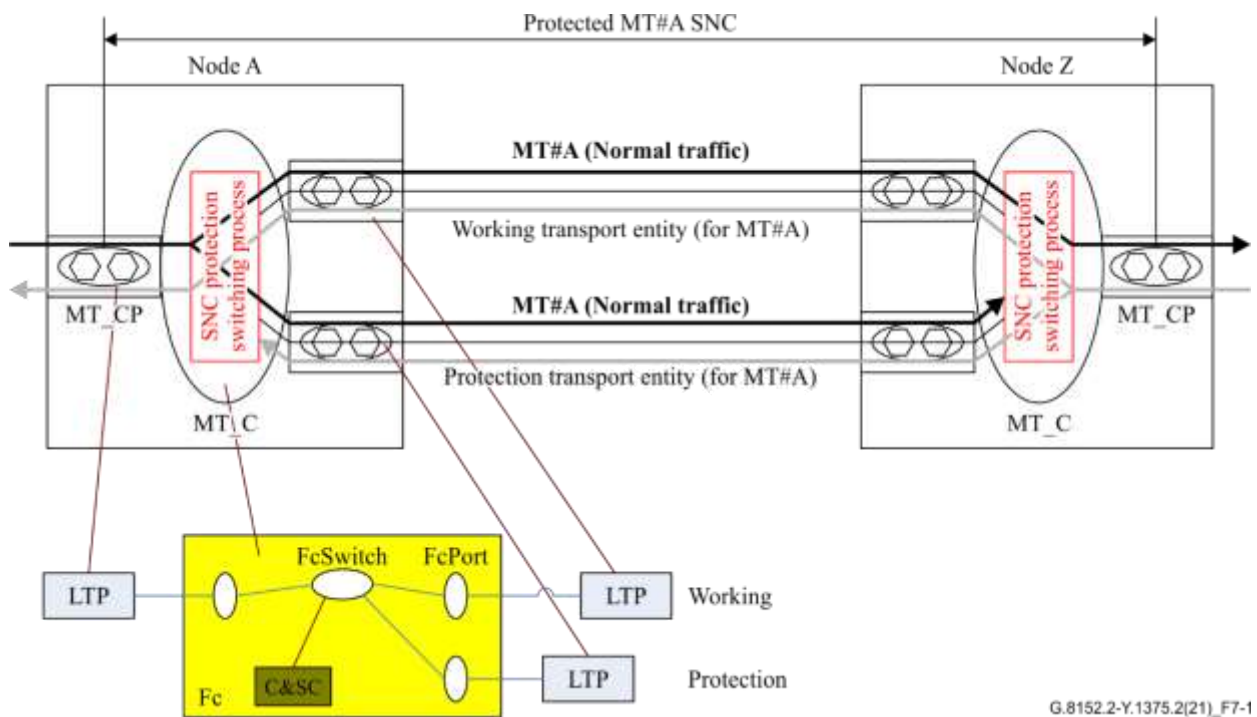

Figure 7-1 – Mapping between [ITU-T G.8131] and [ITU-T G.7711] for MPLS-TP linear protection model

Table 7-1 – Mapping between [ITU-T G.8131], [ITU-T G.8152] and [ITU-T G.7711] for MPLS-TP linear protection

[ITU-T G.8131]	[ITU-T G.8152]	[ITU-T G.7711]
SNCP switching process	MT_SubnetworkConnectionProtectionGroup	FcSwitch+CASC+ Spec
MT_C	MT_CrossConnection	FC+FcPort+Spec
MT_CP	MT_ConnectionTerminationPoint	LTP+Spec

7.1.2 Simplified MPLS-TP linear protection model

The simplified resilience model for MPLS-TP linear protection can be expressed as in Figure 7-2, whose upper part is taken from Figure E.1-1 of [ITU-T G.7711], which shows the basic resilience pattern.

As shown in Figure 7-2, object classes FcSwitch, ConfigurationAndSwitchControl (CASC), and ControlParameters_Pac are used to support resilience.

The FcSwitch object class models the switched forwarding of traffic (traffic flow) between FcPorts and is present where there is protection functionality in the forwarding construct (FC). The FcSwitch represents and determines a protection switch structure encapsulated in the FC and essentially performs one of the functions of the protection group in a traditional information model.

The CASC represents the capability to control and coordinate switches, to add, delete or modify FCs and logical termination points/layer protocols (LTPs/LPs) so as to realize a protection scheme. The CASC can be composed of CASCs allowing for expression of complex control structures, which is called encapsulation of the CASC. There are several degrees of CASC: CASC encapsulated in an FcSwitch, CASC encapsulated in an FC and CASC encapsulated in a CASC.

The ControlParameters_Pac determines a list of control parameters to apply to a switch.

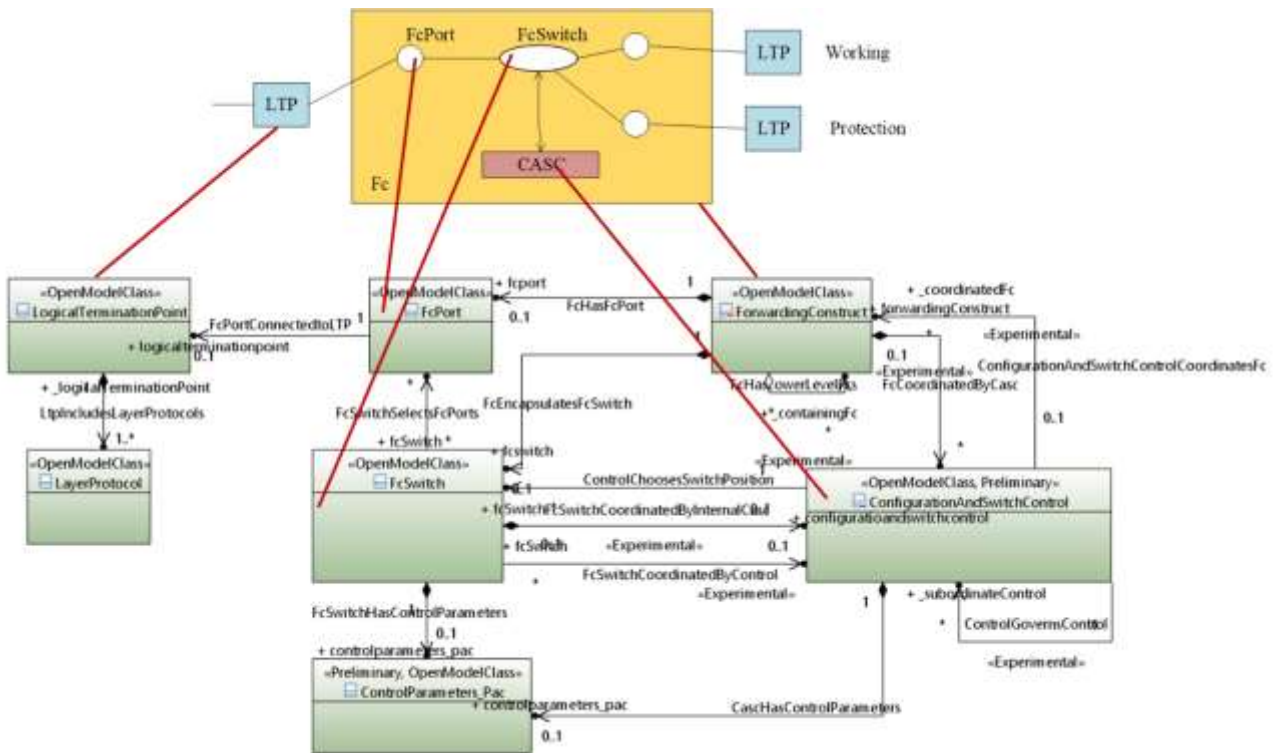

Figure 7-2 – Simplified resilience model for MPLS-TP linear protection

7.1.3 MPLS-TP linear protection attributes and operations

This clause shows how the required ITU-T G.7711 and ITU-T G.8152 object classes are pruned or refactored for linear protection.

In [ITU-T G.8152], MPLS-TP linear protection is modelled by the MT_SNCP_Group object class. Tables 7-2 and 7-3 verify the compatibility at the attribute and operation level between [ITU-T G.8152] and [ITU-T G.7711].

Table 7-2 – Linear protection attribute mapping

	<u>Attributes in [ITU-T G.8152]</u>	<u>Corresponding attributes in [ITU-T G.7711]</u>	<u>Attributes for this Recommendation</u>
<u>1</u>	<u>MT_SubNetworkConnectionProtectionGroup::ProtectionType</u>	It could be modelled as a <u>ControlParameters_Pac</u> specified attribute. This attribute indicates the protection type of the SNCP group.	<u>LinearProtection::protectionType</u> . The datatype for protectionType is pruned and refactored from [ITU-T G.8152].
<u>2</u>	<u>MT_SubNetworkConnectionProtectionGroup::holdOffTime</u>	This attribute already exists in the <u>ControlParameters_Pac</u> .	<u>LinearProtection::protectionType</u> . The datatype for protectionType is pruned and refactored from [ITU-T G.8152].
<u>3</u>	<u>MT_SubNetworkConnectionProtectionGroup::sncpGroupState</u>	It could be modelled as an <u>FcSwitch</u> specified attribute <u>ProtectionState</u> . This attribute indicates the protection state of the SNCP group.	<u>LinearProtection::protectionState</u> , which is Experimental.
<u>4</u>	<u>MT_SubNetworkConnectionProtectionGroup::isSdProtectionEnabled</u>	It could be modelled as an <u>FcSwitch</u> specified attribute <u>isSdProtectionEnabled</u> .	<u>LinearProtection::sdProtectionEnabled</u> . The datatype for protectionType is pruned and refactored from [ITU-T G.8152].

Table 7-3 –Linear protection operations mapping

	<u>Operations in [ITU-T G.8152]</u>	<u>Corresponding attributes in [ITU-T G.7711]</u>	<u>Operations for this Recommendation</u>
<u>1</u>	<u>MT_SubNetworkConnectionProtectionGroup::lockoutProtection()</u>	Use the operation of CASC to set <u>FcSwitch</u> to <i>lockout</i> . In clause E.1.2.6 of [ITU-T G.7711], the FC switch represents and determines a protection switch structure encapsulated in the FC and essentially performs one of the functions of the protection group in a traditional model. It may be locked out (prevented from switching), force switched or manual switched.	Action Command, with one input parameter (commandType) determining the type of command. For this one, the command type is <u>LOCKOUT OF PROTECTION</u> .
<u>2</u>	<u>MT_SubNetworkConnectionProtectionGroup::forceSwitch()</u>	Use the operation of CASC to set <u>FcSwitch</u> to <i>force switch</i> .	Action Command, with one input parameter (commandType) determining the type of command. For this one, the command type is <u>FORCED_SWITCH</u> .
<u>3</u>	<u>MT_SubNetworkConnectionProtectionGroup::clearExternalCommandAndWTRstate()</u>	Use the operation of CASC to set <u>FcSwitch</u> to <i>clear</i> . May need to add "clear" to <u>FcSwitch::Switchcontrol</u> . So, it may be described by the operations of CASC. <u>ControlParameters_Pac</u> already has <u>WaitToRestoreTime</u> attributes.	Action Command, with one input parameter (commandType) determining the type of command. For this one, the command type is <u>CLEAR</u> .

Table 7-3 –Linear protection operations mapping

	<u>Operations in [ITU-T G.8152]</u>	<u>Corresponding attributes in [ITU-T G.7711]</u>	<u>Operations for this Recommendation</u>
<u>4</u>	<u>MT_SubNetworkConnectionProtectionGroup::manualSwitch()</u>	<p><u>Set the selectedFcPort attribute of FcSwitch to the designated switching port (either the protecting port or the working port).</u></p> <p><u>The attribute switchControl of FcSwitch already has the value MANUAL.</u></p>	<p><u>Action Command, with one input parameter (commandType) determining the type of command. For this one, the command type are</u> <u>MANUAL_SWITCH_TO_WORKING,</u> <u>MANUAL_SWITCH_TO_PROTECTION.</u></p>
<u>5</u>	<u>MT_SubNetworkConnectionProtectionGroup::exercise()</u>	<u>No description of exercise in [ITU-T G.7711].</u>	<p><u>Action Command, with one input parameter (commandType) determining the type of command. For this one, the command type is EXERCISE.</u></p>
<u>6</u>	<u>MT_SubNetworkConnectionProtectionGroup::localFreeze()</u>	<u>Set the isFroze attribute of ConfigurationAndSwitchControl to true.</u>	<p><u>Action Command, with one input parameter (commandType) determining the type of command. For this one, the command type is FREEZE.</u></p>
<u>7</u>	<u>MT_SubNetworkConnectionProtectionGroup::clearLocalFreeze()</u>	<u>Set the isFroze attribute of ConfigurationAndSwitchControl to false.</u>	<p><u>Action Command, with one input parameter (commandType) determining the type of command. For this one, the command type is CLEAR_FREEZE.</u></p>

[ITU-T G.8152] only describes the attributes and operations in Table 7-2 and Table 7-3. However, according to [ITU-T G.8131], this Recommendation may also include the attributes listed in Table 7-4.

Table 7-4 – Linear protection attributes verification

	<u>Attributes in [ITU-T G.8131]</u>	<u>Corresponding attributes in [ITU-T G.7711]</u>	<u>Attributes for this Recommendation</u>
<u>1</u>	<u>Clause 7 of [ITU-T G.8131] describes the selection of the working connection or protection connection</u>	<u>FcPort already has an attribute "role" to describe the role of the port.</u>	<u>FcPort::role, specify the data type of attribute role, the specified value including: WORKING, PROTECTING, PROTECTED, NA.</u>
<u>2</u>	<u>Clause 6.3.2 of [ITU-T G.8131] on revertive operation</u>	<u>Use the ControlParameters_Pac.</u>	<u>LinearProtection::reversionMode.</u>

7.1.4 Relationship between MPLS-TP linear protection and reverse-engineered IETF UML models

7.1.4.1 Relationship between the MPLS-TP linear protection and the reverse-engineered IETF connection-oriented OAM UML models

The ITU-T G.8152.2 YANG references the IETF RFC 8531 connection-oriented OAM YANG to identify the maintenance association (MA) monitoring the working and protection transport entities.

To assist MPLS-TP linear protection UML pruning and refactoring, and to ensure the translated MPLS-TP linear protection YANG can seamlessly refer to the IETF RFC 8531 connection-oriented OAM YANG, the connection-oriented OAM modules have been manually reverse-engineered into UML form. Therefore, the ITU-T G.8152.2 UML model will thus also refer to the reverse-engineered IETF RFC8531 connection-oriented OAM UML.

Figure 7-3 provides an overview of the relationship between the connection-oriented OAM classes and the [ITU-T G.8152.2] classes. It illustrates, at high level that:

- The *LinearProtectionPac* object class has two reference associations to *Ma* of the connection-oriented OAM model to indicate the working path *Ma* and the protection path *Ma*. Note that these two associations have a restriction that they shall point to two different instances of *Ma*. Such restriction is modelled by using the "Cond" stereotype of the "*LinearProtectionHasProtectionPathMa*" association.

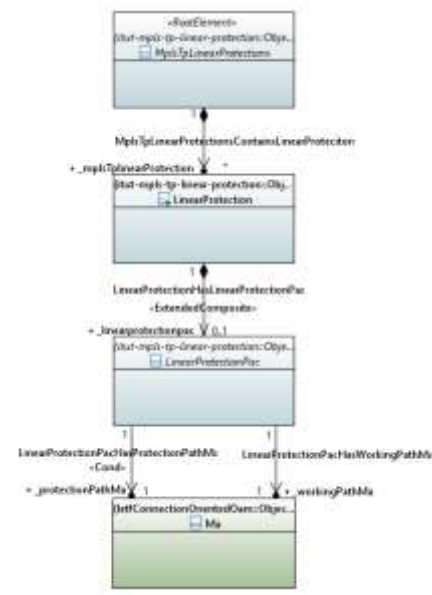

Figure 7-3 – Relationship between the IETF connection-oriented OAM and the ITU-T linear protection models

7.1.5 MPLS-TP linear protection model

The following text describes the MPLS-TP linear protection ~~specification~~-model.

In Figure 7-34, the following colour convention is used for the object classes: orange – from the ITU-T G.7711 core model; blue – specified in this Recommendation; ~~pink – pruned and refactored from [ITU-T G.7711], but in need of further refactoring~~green – from IETF connection-oriented OAM; and yellow – from [ITU-T G.8152].

In this Recommendation, the LinearProtection object class models the switched forwarding of traffic (traffic flow) for linear protection, and is ~~pruned and refactored from [ITU-T G.7711] FcSwitch and ControlParameters Pac object classes and [ITU-T G.8152] MT_SubNetworkConnectionProtectionGroup object class and it is "ExtendedComposite" with the MPLS-TP linear protection specific attributes defined in LinearProtectionPac abstract object class. The Actions interface class is used to receive the commands for switching. Additionally, it is used to control and coordinate linear protection groups, to add, delete or modify FCs and LTPs/LPs so as to realize a protection scheme. It also determines a list of control parameters to apply to a switch. The LinearProtectionPac object class defined in this Recommendation has two references associations with the IETF reverse-engineered connection-oriented OAM Ma object class, and used to configure the Ma to monitor the working and protection transport entities respectively. The Actions interface class determines the operations for linear protection, and they are pruned and refactored from [ITU-T G.8152].~~

~~The pink object classes need to be further refactored into UML artefacts that are supposed to be re-engineered from [b-IETF-mpls-base] and [b-IETF-mpls-static].~~

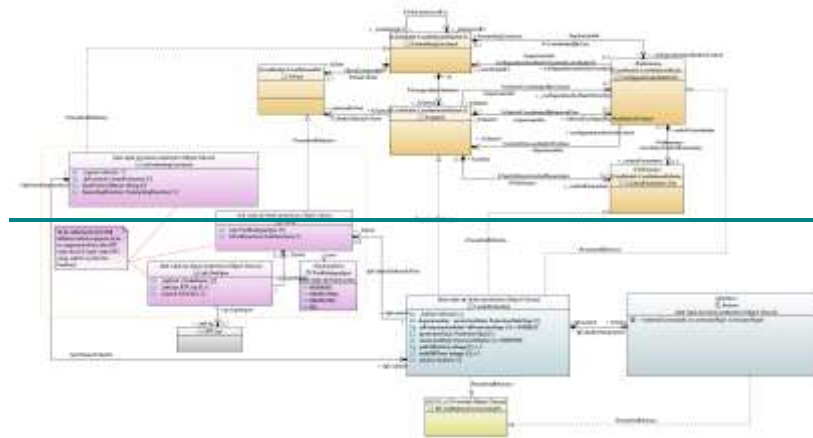

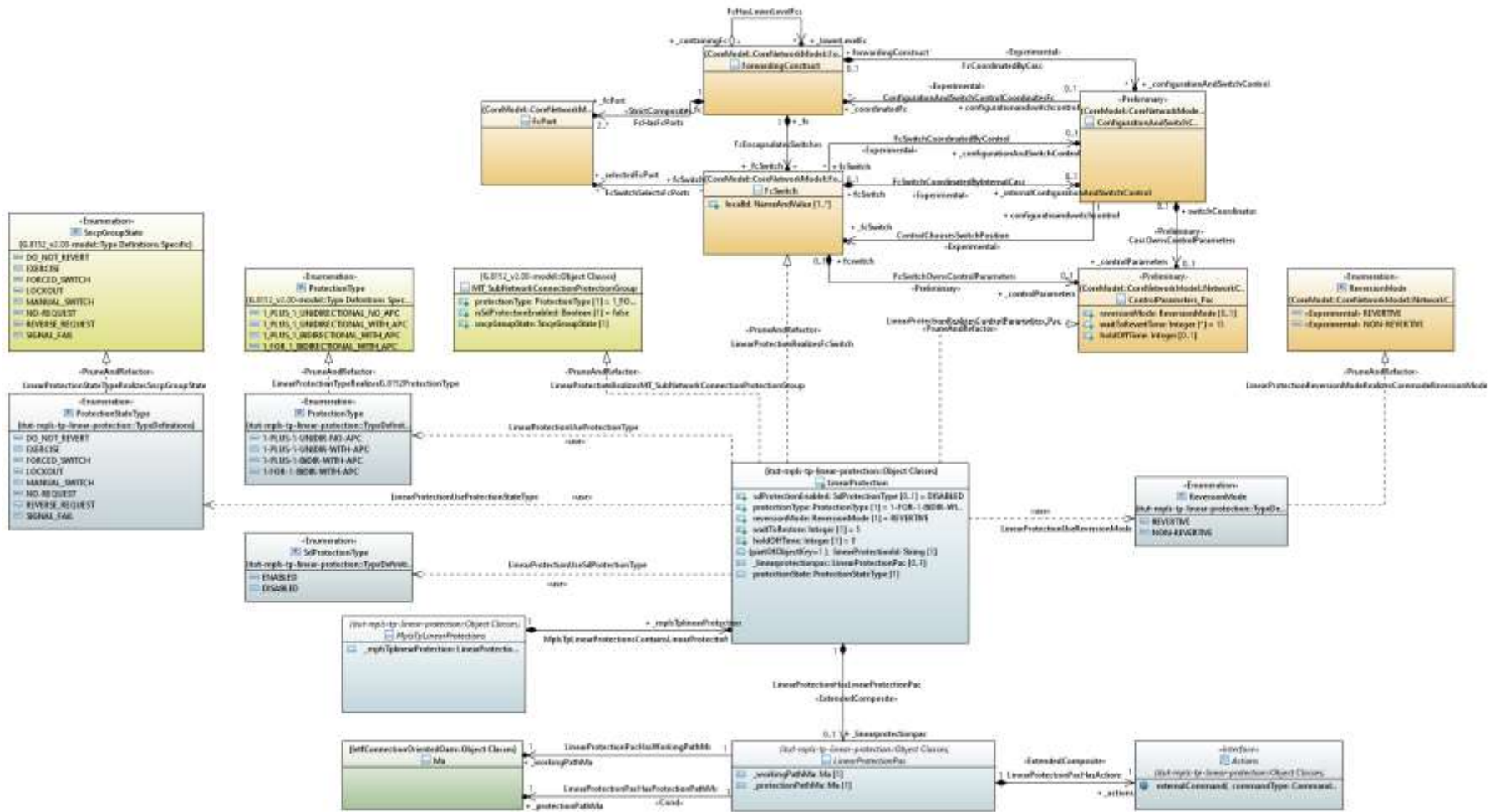

Figure 7-34 – MPLS-TP linear protection-specification model

7.1.2 Shared ring protection

Figure 8-1 of [ITU-T G.8132] presents the function model of MSRP (see the upper part of Figure 7-4). Annex E of [ITU-T G.7711] specifies the generic resilience information model. Figure 7-4 shows the mapping between the ITU-T G.8132 MSRP functions and the ITU-T G.7711 information model artefacts for the MSRP.

An MSRP ring tunnel is modelled as a server sub-layer for the MPLS-TP label switched path (LSP) sub-layer. Figure 8-1 of [ITU-T G.8132] shows the sub-layer functional model. The MSRP_C shows all the possible working and protection connections that can be set up in the MSRP sub-layer. See Table 7-2.

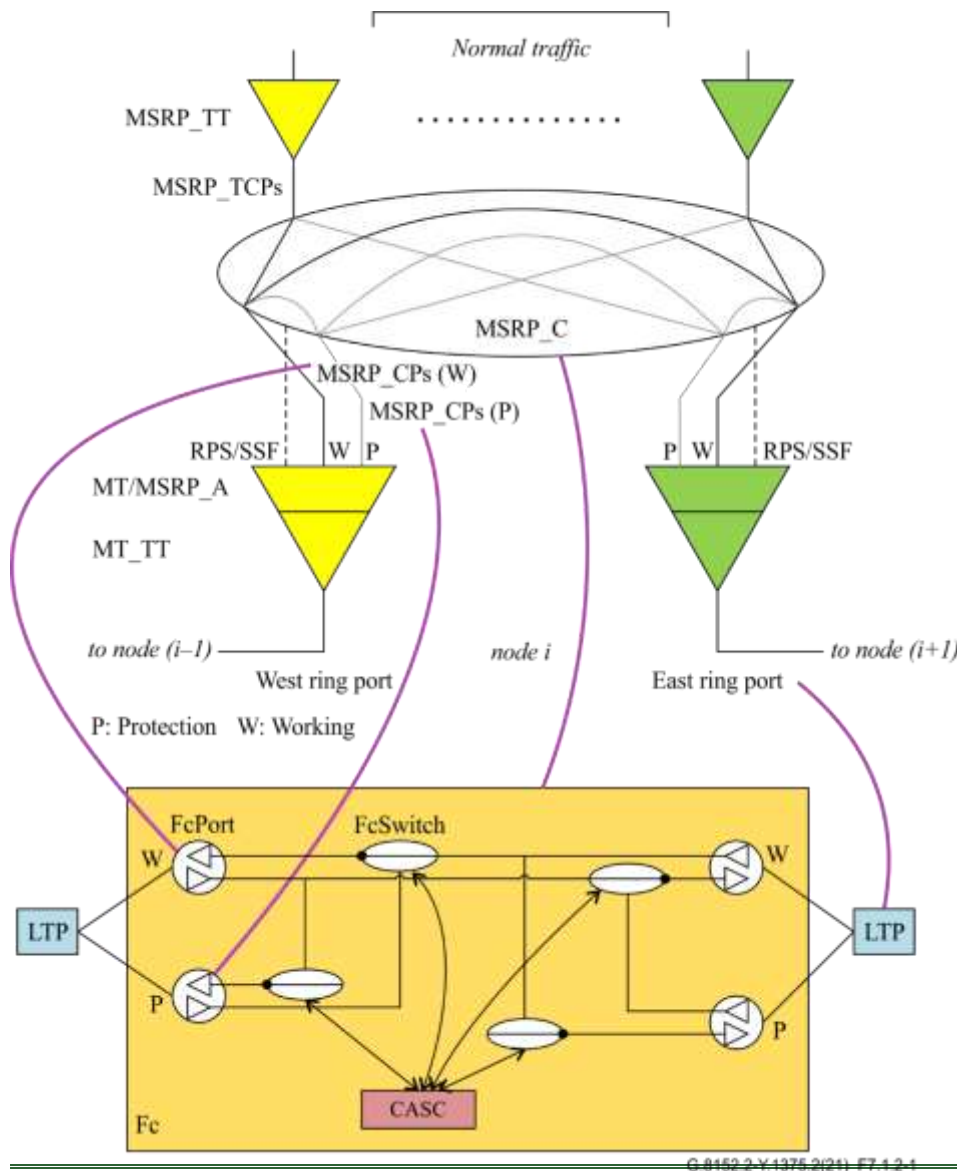

Figure 7-4 Mapping between MSRP functions and information model artefacts

Table 7-2 Mapping between [ITU-T G.8132], [ITU-T G.8152] and [ITU-T G.7711] for MSRP

[ITU-T G.8132]	[ITU-T G.8152]	[ITU-T G.7711]
MSRP switching process	Not yet determined	FeSwitch+CASC+Spec
MSRP_C	Not yet determined	FC+Spec
MSRP_CP	Not yet determined	FePort+Spec
West ring port/East ring port	MT_TrailTerminationPoint	LTP+Spec

The simplified resilience model for MSRP can be expressed as in Figure 7-5.

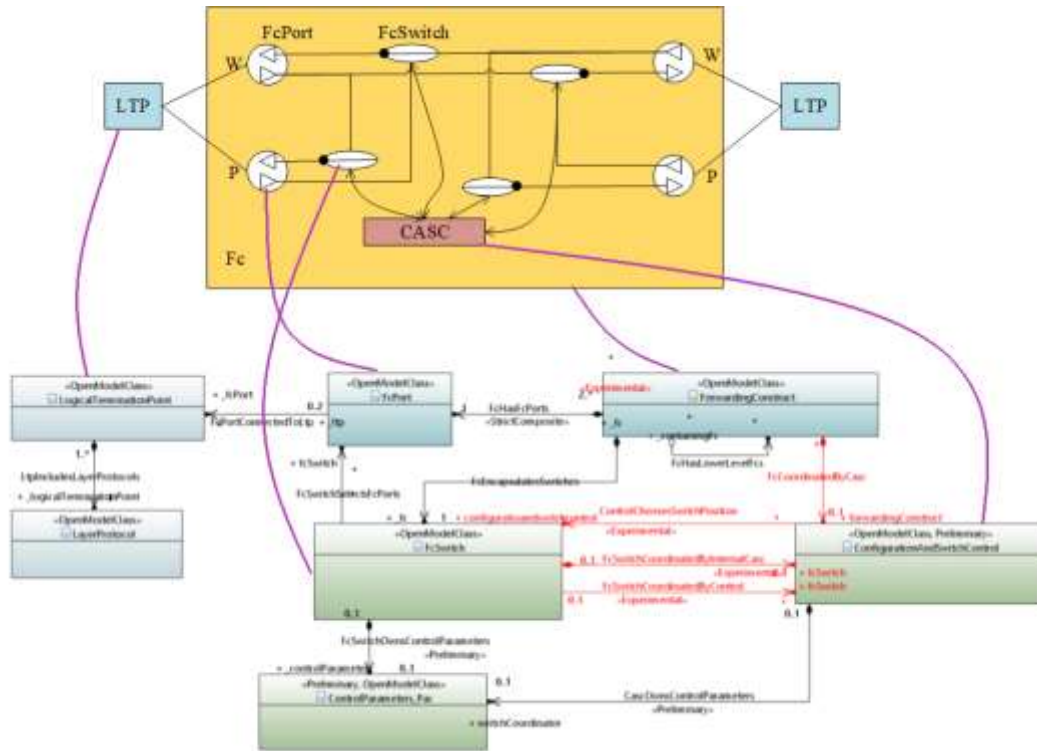

Figure 7-5 Simplified resilience model for MSRP

The descriptions for the FeSwitch, CASC, and ControlParameters_Pac object classes are the same in clause 7.1.1.

The following text describes the MSRP specification models. The colour convention of Figure 7-3 is used in Figure 7-6:

The Srp_FcSwitch object class models the switched forwarding of traffic (traffic flow), and is pruned and refactored from [ITU-T G.7711] and [ITU-T G.8152]. The Srp_casc is used to control and coordinate instances of FeSwitch, to add, delete or modify FCs and LTPs/LPs so as to realize a protection scheme. The ControlParameters_Pac determines a list of control parameters to apply to a switch. The SRP_CaseActions interface class determines the operations for shared ring protection.

The pink object classes need to be further refactored into UML artefacts that are supposed to be re-engineered from [b-IETF-mpls-base] and [b-IETF-mpls-static].

~~Figure 7-7 shows the Fe instance model that is used to describe the relationship between the ring tunnel and LSP. The MSRP ring tunnel is modelled as a server sub-layer for the MPLS-TP LSP sub-layer. As shown in Figure 7-7, a RingTunnelFe instance has a lower level LSPFe instance.~~

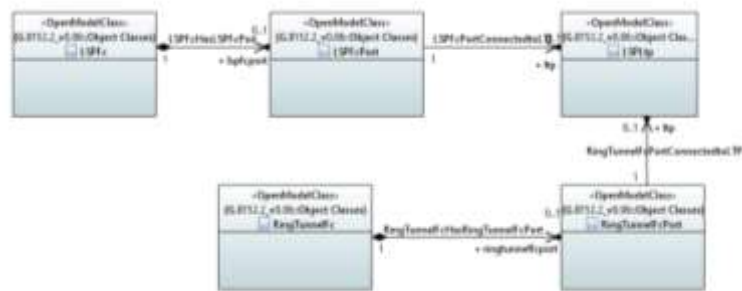

~~Figure 7-7 Fe instance~~

~~Annex A describes the principles of MSRP and a method of using the MSRP resilience model to represent the MSRP, as well as a switching method according to failures.~~

7.2 Required attributes and operations MPLS-TP shared ring protection information model

7.2.1 Linear protection

~~This clause shows how the required ITU-T G.7711 and ITU-T G.8152 object classes are pruned or refactored for linear protection.~~

~~In [ITU-T G.8152], MPLS-TP linear protection is modelled by the MT_SNCP_Group object class. Tables 7-3 to 7-5 verify the compatibility at the attribute and operation level between [ITU-T G.8152] and [ITU-T G.7711].~~

~~Table 7-3 Linear protection attribute mapping~~

	Attributes in [ITU-T G.8152]	Corresponding attributes in [ITU-T G.7711]	Attributes for this Recommendation
1	MT_SubNetworkConnectionProtectionGroup::ProtectionType	It could be modelled as a ControlParameters_Pac specified attribute. This attribute indicates the protection type of the SNCP group.	LinearProtection::protectionType. The datatype for protectionType is pruned and refactored from [ITU-T G.8152].
2	MT_SubNetworkConnectionProtectionGroup::holdOffTime	This attribute already exists in the ControlParameters_Pac.	LinearProtection::protectionType. The datatype for protectionType is pruned and refactored from [ITU-T G.8152].
3	MT_SubNetworkConnectionProtectionGroup::snepGroupState	It could be modelled as an FeSwitch specified attribute ProtectionState. This attribute indicates the protection state of the SNCP group.	LinearProtection::protectionState, which is Experimental.
4	MT_SubNetworkConnectionProtectionGroup::isSdProtectionEnabled	It could be modelled as an FeSwitch specified attribute isSdProtectionEnabled.	LinearProtection::sdProtectionEnabled. The datatype for protectionType is pruned and refactored from [ITU-T G.8152].

Table 7-4 Linear protection operations mapping

	Operations in [ITU-T G.8152]	Corresponding attributes in [ITU-T G.7711]	Operations for this Recommendation
1	MT_SubNetworkConnectionProtectionGroup::lockoutProtection()	Use the operation of CASC to set FeSwitch to <i>lockout</i>. In clause E.1.2.6 of [ITU-T G.7711], the FC switch represents and determines a protection switch structure encapsulated in the FC and essentially performs one of the functions of the protection group in a traditional model. It may be locked out (prevented from switching), force switched or manual switched.	Action Command, with one input parameter (commandType) determining the type of command. For this one, the command type is LOCKOUT_OF_PROTECTION.
2	MT_SubNetworkConnectionProtectionGroup::forceSwitch()	Use the operation of CASC to set FeSwitch to <i>force switch</i>.	Action Command, with one input parameter (commandType) determining the type of command. For this one, the command type is FORCED_SWITCH.
3	MT_SubNetworkConnectionProtectionGroup::clearExternalCommandAndWTRstate()	Use the operation of CASC to set FeSwitch to <i>clear</i>. May need to add "clear" to FeSwitch::SwitchControl. So, it may be described by the operations of CASC. ControlParameters_Pac already has WaitToRestoreTime attributes.	Action Command, with one input parameter (commandType) determining the type of command. For this one, the command type is CLEAR.
4	MT_SubNetworkConnectionProtectionGroup::manualSwitch()	Set the selected FePort attribute of FeSwitch to the designated switching port (either the protecting port or the working port). The attribute switchControl of FeSwitch already has the value MANUAL.	Action Command, with one input parameter (commandType) determining the type of command. For this one, the command type are MANUAL_SWITCH_TO_WORKING, MANUAL_SWITCH_TO_PROTECTION.
5	MT_SubNetworkConnectionProtectionGroup::exercise()	No description of exercise in [ITU-T G.7711].	Action Command, with one input parameter (commandType) determining the type of command. For this one, the command type is EXERCISE.
6	MT_SubNetworkConnectionProtectionGroup::localFreeze()	Set the isFroze attribute of ConfigurationAndSwitchControl to <i>true</i>.	Action Command, with one input parameter (commandType) determining the type of command. For this one,

Table 7-4 Linear protection operations mapping

	Operations in [ITU-T G.8152]	Corresponding attributes in [ITU-T G.7711]	Operations for this Recommendation
			the command type is FREEZE.
7	MT_SubNetworkConnectionProtectionGroup::clearLocalFreeze()	Set the isFroze attribute of ConfigurationAndSwitchControl to false.	Action Command, with one input parameter (commandType) determining the type of command. For this one, the command type is CLEAR_FREEZE.

~~[ITU-T G.8152] only describes the attributes and operations in Table 7-3 and Table 7-4. However, according to [ITU-T G.8131], this Recommendation may also include the attributes listed in Table 7-5.~~

Table 7-5 Linear protection attributes verification

	Attributes in [ITU-T G.8131]	Corresponding attributes in [ITU-T G.7711]	Attributes for this Recommendation
±	Clause 7 of [ITU-T G.8131] describes the selection of the working connection or protection connection	FcPort already has an attribute "role" to describe the role of the port.	FcPort::role, specify the data type of attribute role, the specified value including: WORKING, PROTECTING, PROTECTED, NA.
≥	Clause 6.3.2 of [ITU-T G.8131] on revertive operation	Use the ControlParameters_Pae.	LinearProtection::reversionMode.

7.2.1 Mapping between ITU-T G.8132 and ITU-T G.8152 and ITU-T G.7711 for MPLS-TP shared ring protection

Figure 8-1 of [ITU-T G.8132] presents the function model of MSRP (see the upper part of Figure 7-5). Annex E of [ITU-T G.7711] specifies the generic resilience information model. Figure 7-5 shows the mapping between the ITU-T G.8132 MSRP functions and the ITU-T G.7711 information model artefacts for the MSRP.

An MSRP ring tunnel is modelled as a server sub-layer for the MPLS-TP label switched path (LSP) sub-layer. Figure 8-1 of [ITU-T G.8132] shows the sub-layer functional model. The MSRP_C shows all the possible working and protection connections that can be set up in the MSRP sub-layer. See Table 7-5.

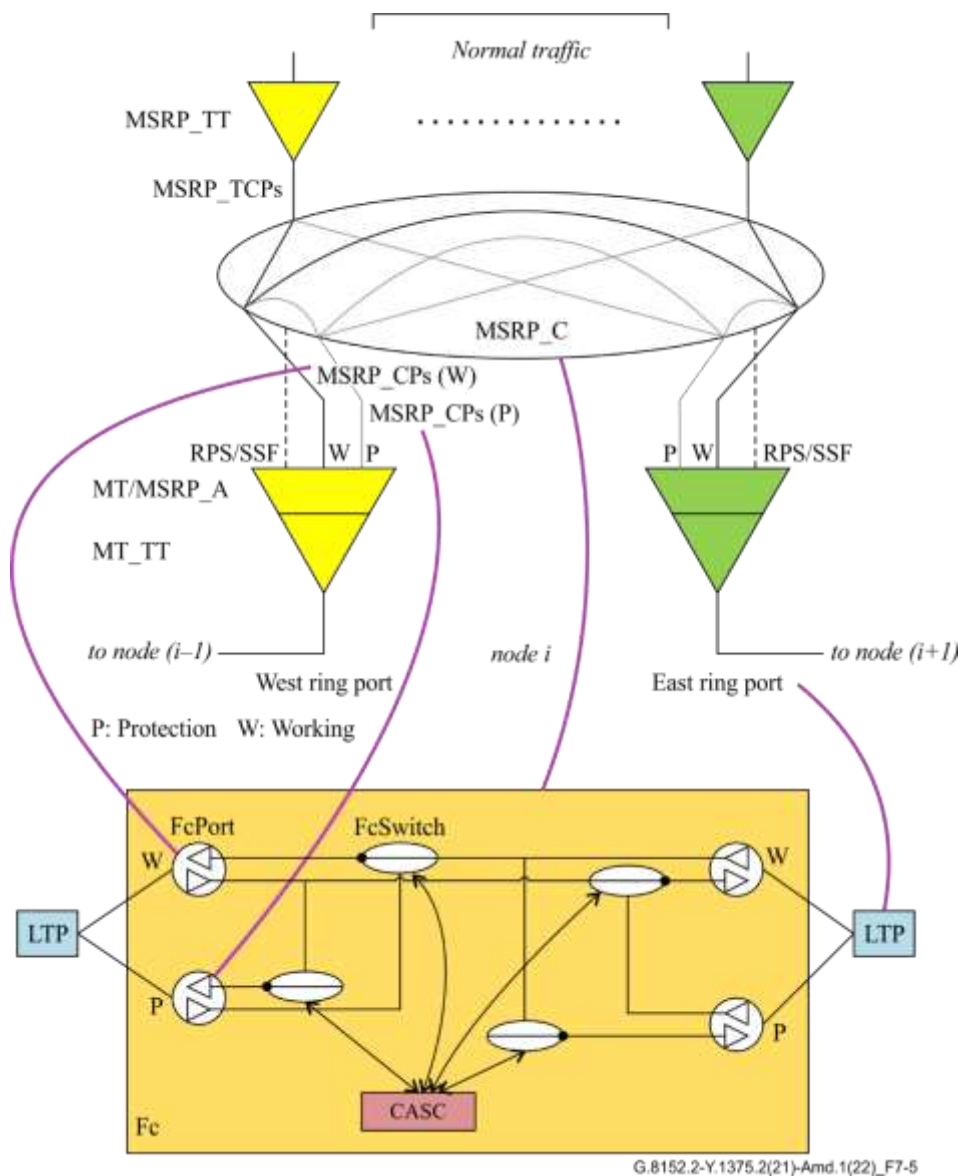

Figure 7-5 – Mapping between MSRP functions and information model artefacts

Table 7-5 – Mapping between [ITU-T G.8132], [ITU-T G.8152] and [ITU-T G.7711] for MSRP

<u>[ITU-T G.8132]</u>	<u>[ITU-T G.8152]</u>	<u>[ITU-T G.7711]</u>
<u>MSRP switching process</u>	<u>Not yet determined</u>	<u>FcSwitch+CASC+ Spec</u>
<u>MSRP_C</u>	<u>Not yet determined</u>	<u>FC+ Spec</u>
<u>MSRP_CP</u>	<u>Not yet determined</u>	<u>FcPort +Spec</u>
<u>West ring port/East ring port</u>	<u>MT_TrailTerminationPoint</u>	<u>LTP +Spec</u>

7.2.2 Simplified MPLS-TP shared ring protection model

The simplified resilience model for MSRP can be expressed as in Figure 7-6.

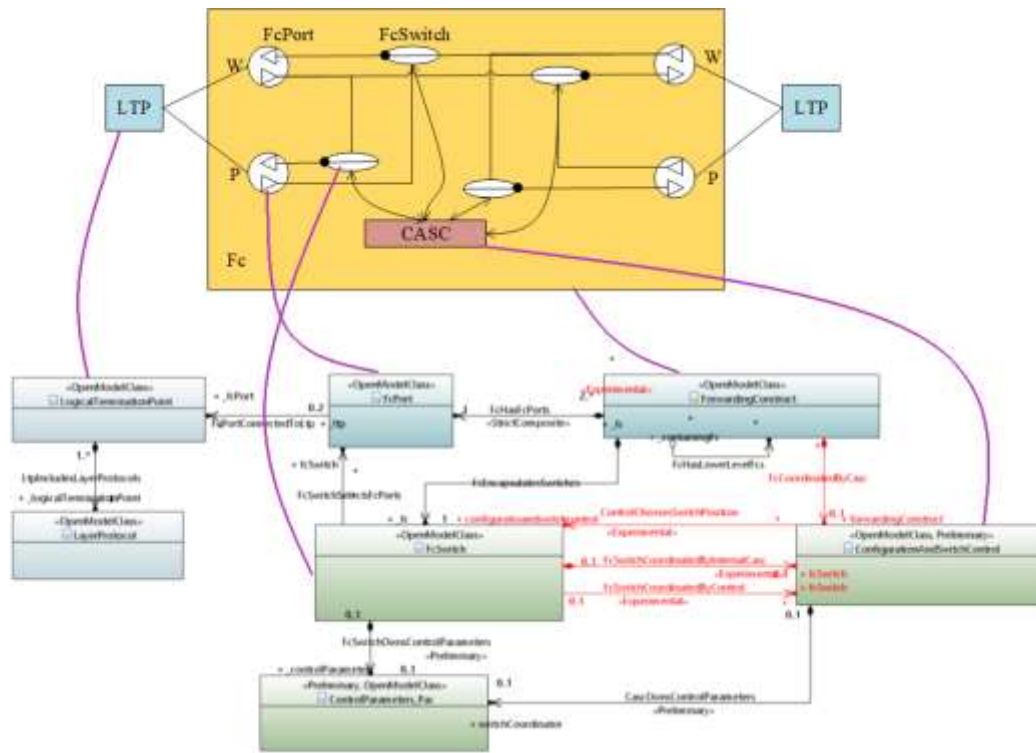

Figure 7-6 – Simplified resilience model for MSRP

The descriptions for the FcSwitch, CASC, and ControlParameters_Pac object classes are the same in clause 7.1.1.

7.2.23 Shared ring protection MPLS-TP shared ring protection attributes and operations

This clause shows how the required ITU-T G.7711 and ITU-T G.8152 object classes are pruned or refactored for MSRP.

In [ITU-T G.8152], there is no object class specified for MSRP. Tables 7-6 and 7-7 provide the mapping between the ITU-T G.8132 MSRP characteristics and the information artefacts according to the MSRP model in clause 7.1.2.

Table 7-6 – MSRP attribute mapping

	Attributes in [ITU-T G.8132]	Corresponding attributes in [ITU-T G.7711]	Attributes for this Recommendation
1	Three types of ring protection mechanism are specified: wrapping; short wrapping; and steering	Use ControlParameters_Pac::protType. But the values of protType are not defined	ControlParameters_Pac::protType. As CIM does not describe the data type values for protType, the values are those specified in [ITU-T G.8132].
2	MSRP supports only the bi-directional protection switching type	Use the switchingType attribute of FcSwitch	FcSwitch::SwitchingType, this attribute is specified from [ITU-T G.8132].
3	Revertive protection operation type	Use ControlParameters_Pac::reversionMode.	ControlParameters_Pac::reversionMode

Table 7-6 – MSRP attribute mapping

	Attributes in [ITU-T G.8132]	Corresponding attributes in [ITU-T G.7711]	Attributes for this Recommendation
4	Ring protection switch state	Use the ringProtectionState attribute of FcSwitch	FcSwitch::RingProtectionState, this attribute is specified from [ITU-T G.8132].
5	Wait-to-restore	Use ControlParameters_Pac::waitToRevertTime	ControlParameters_Pac::waitToRevertTime

Table 7-7 – MSRP operations mapping

	Operations in [ITU-T G.8132]	Corresponding attributes in [ITU-T G.7711]	Operations for this Recommendation
1	Lockout of Protection(LP), Lockout of Working(LW)	Use the operation of CASC to set FcSwitch to <i>lockout</i>	CASC specified operations::lockout() and specified parameter lockOutType will describe the type: lockout to protection or lockout to working.
2	Forced switch (FS)	Use the operation of CASC to set FcSwitch to <i>forceSwitch</i>	CASC specified operations::forceSwitch()
3	Manual switch (MS)	Set the _selectedFcPort attribute of FcSwitch	CASC specified operations::manualSwitch()
4	Exercise (EXER)	No description of <i>exercise</i> in [ITU-T G.7711]	CASC specified operations::exercise()
5	Clear: clears the administrative command and WTR timer	Use the operation of CASC to set FcSwitch to <i>clear</i>	CASC specified operations::clearAdministratorCommandAndWTRstate()
6	Automatically initiated command	Set FcSwitch automatically.	CASC specified operations::automatic()

7.2.4 MPLS-TP shared ring protection model

The following text describes the MSRP specification models. The colour convention of Figure 7-4 is used in Figure 7-7.

The Srp_FcSwitch object class models the switched forwarding of traffic (traffic flow), and is pruned and refactored from [ITU-T G.7711] and [ITU-T G.8152]. The Srp_casc is used to control and coordinate instances of FcSwitch, to add, delete or modify FCs and LTPs/LPs so as to realize a protection scheme. The ControlParameters_Pac determines a list of control parameters to apply to a switch. The SRP_CascActions interface class determines the operations for shared ring protection.

The pink object classes need to be further refactored into UML artefacts that are supposed to be re-engineered from [b- IETF-mpls-base] and [b-IETF-mpls-static].

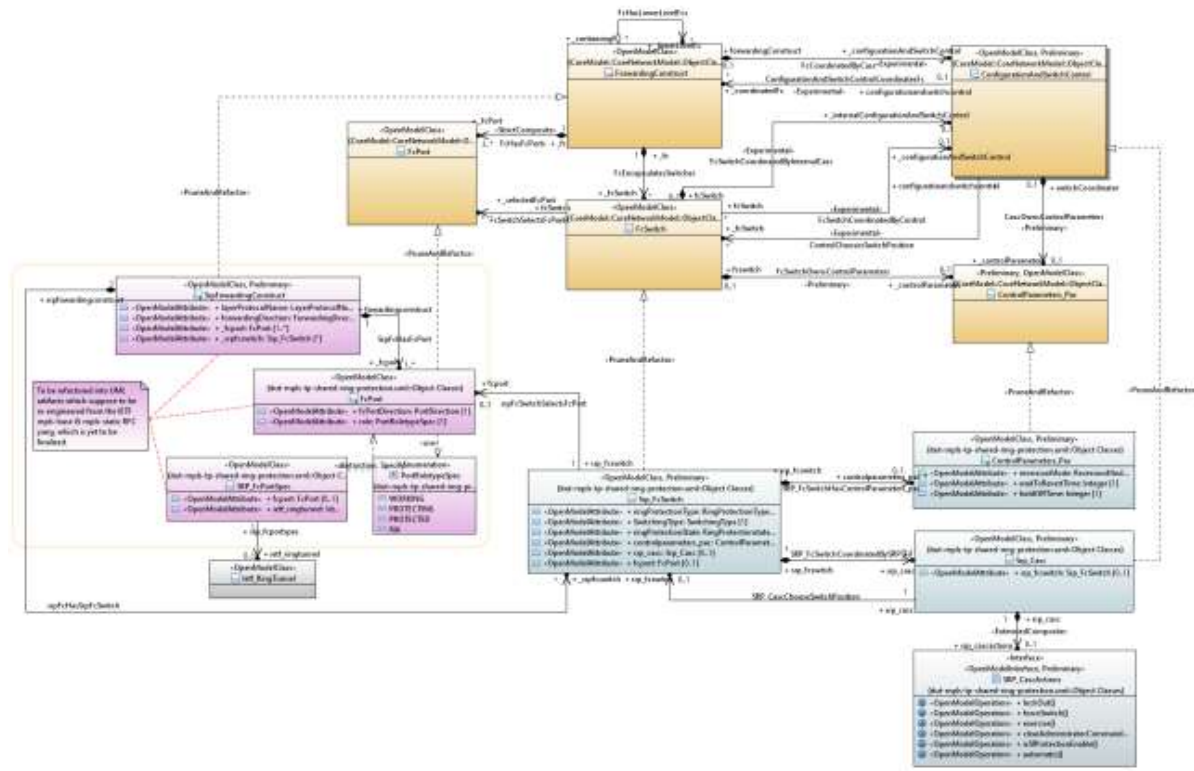

Figure 7-7 – MSRP specification model

Figure 7-8 shows the Fc instance model that is used to describe the relationship between the ring tunnel and LSP. The MSRP ring tunnel is modelled as a server sub-layer for the MPLS-TP LSP sub-layer. As shown in Figure 7-8, a RingTunnelFc instance has a lower level LSPFc instance.

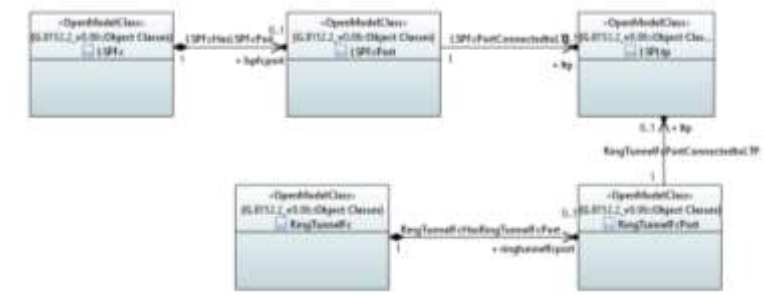

Figure 7-8 – Fc instance

Annex A describes the principles of MSRP and a method of using the MSRP resilience model to represent the MSRP, as well as a switching method according to failures.

7.3 UML model files

7.3.1 Linear protection

The linear protection UML model developed using the Papyrus open-source modelling tool can be found at: https://www.itu.int/ITU-T/formal-language/itu-t/g/g8152.2/2021/g8152.2_v1.00_uml.zip.
https://www.itu.int/ITU-T/formal-language/itu-t/g/g8152.2/2022/g8152.2v1.1_uml.zip

This zip file contains the following folders:

- The [G.8152.2 folder, which UML model consisting of contains](#) the following files:
 - The Papyrus project file;
 - o .project;
 - The .di, .notation, and .uml files of the linear protection module;
 - o itut-mpls-tp-linear-protection.di;
 - o itut-mpls-tp-linear-protection.notation;
 - o itut-mpls-tp-linear-protection.uml;
 - [The doc sub-folder, which contains the data dictionary of the itut-mpls-tp-linear-protection UML modle](#)
 - [The UMLml-profiles sub-folder, which contains the UML Profiles that determine defines](#) the properties of the UML artefact.
 - o [The OpenModelProfile folder, which contains the .di, .notation, and uml of the open model profile.](#)
 - o [The OpenInterfaceModelProfile folder, which contains the .di, .notation, and uml of the open model interface profile.](#)
 - o [The ProfileLifecycleProfile folder, which contains the .di, .notation, and uml of the profile lifecycle profile.](#)
 - o [The ClassDiagramStyleSheet.css style sheet.](#)
 - [The diagrams sub-folder, which contains the PNG images of all the class diagrams.](#)
- [The G.7711 folder, which contains the \[ITU-T G.7711\] Core model that is needed \(i.e., imported\) by the G.8152.2 model.](#)

- [The G.8152 folder, which contains the \[ITU-T G.8152\] MPLS-TP model that is needed \(i.e., imported\) by the G.8152.2 model.](#)
- [The IetfModels folder, which contains the IETF model that is needed \(i.e., imported\) by the G.8152.2 model.](#)

NOTE – If the imported model has been up-versioned or has changed the module name, then the xmi code of the G.8152.2 module will need to be updated.

- ~~• [The UML models that are needed \(i.e., imported\) by this model.](#)~~
 - ~~— [ITU-T G.7711 core information model;](#)~~
 - ~~— [ITU-T G.8152-based MPL-TP information model;](#)~~
 - ~~— [IETF IetfConnectionOrientedOam reverse-engineered UML model;](#)~~
 - ~~— [IETF IetfMplsStatic reverse-engineered UML model.](#)~~

7.3.2 Ring protection

The zip file containing the shared ring protection UML model developed using the Papyrus open-source modelling tool can be found at: <https://www.itu.int/ITU-T/formal-language/itu-t/g/g8152.2/2021/itut-mpls-tp-shared-ring-protection.zip>. Note that this model is preliminary and still requires further development.

8 MPLS-TP resilience data models

This clause contains the interface-protocol-specific data models of the MPLS-TP resilience functions identified in clause 6. These data models are translated from the interface-protocol-neutral UML information specified in clause 7.

8.1 MPLS-TP YANG data model

This clause contains the YANG data model.

The YANG data models specified in this Recommendation use the YANG 1.1 language specified in [IETF RFC 7950]. The tree format specified in [IETF RFC 8340] is used for the YANG data model tree representation. The YANG data models specified in this Recommendation conform to the network management datastore architecture specified in [IETF RFC 8342].

8.1.1 Linear protection

The linear protection YANG model is translated from the UML information provided in clause 7.3.1. The translation is done with the assistance of the open source translation tooling xmi2yang, which has been developed according to the mapping guidelines of [b-ONF TR-531].

At the time of publication of this Recommendation, the xmi2yang mapping tool is still work in progress. Therefore, manual modifications of the tool-generated yang are necessary. The yang with such manual modifications can be found at https://www.itu.int/ITU-T/formal-language/itu-t/g/g8152.2/2021/g8152.2_v1.00_yang.zip https://www.itu.int/ITU-T/formal-language/itu-t/g/g8152.2/2022/g8152.2v1.1_yang.zip.

8.1.2 Ring protection

Since the base UML model of shared ring protection is still preliminary, the YANG model is also preliminary and needs further study.

Annex A

MSRP information model

(This annex forms an integral part of this Recommendation.)

The focus of this annex is the modelling of shared ring protection. It:

- introduces the MSRP resilience principle;
- shows how the model deals with failures.

The MSRP architecture is specified in [ITU-T G.8132]. This clause gives an overview of the architecture to be used to describe the MSRP management information model. As shown in Figure A.1, the new logical layer consists of ring tunnels that provide a server layer for the LSPs traversing the ring. The notation used for a ring tunnel is: R<d><p>_<X> where <d> = c (clockwise) or a (anticlockwise), <p> = W (working) or P (protecting), and <X> = the node name.

Once a ring tunnel is established, the forwarding and protection switching of the ring are all performed at the ring tunnel level. MPLS-TP section layer operations, administration and maintenance (OAM) is needed for continuity check, remote defect indication and fault detection, and protection operations are controlled by the ring protection switching protocol described in [IETF RFC 8227]. A port can carry multiple ring tunnels, and a ring tunnel can carry multiple LSPs.

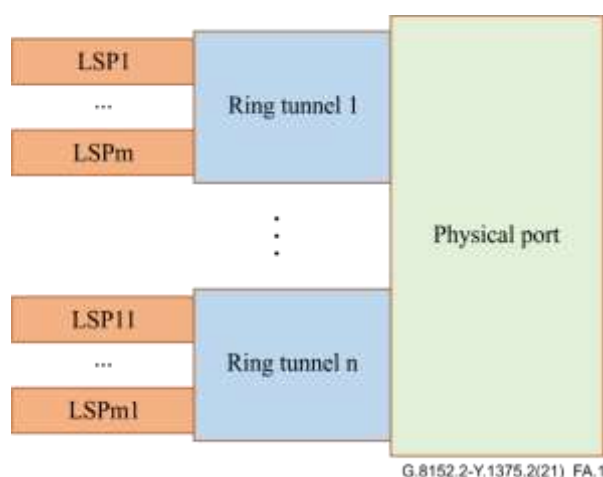

Figure A.1 – The logic layers of the ring

The ring tunnels are established based on the egress nodes. The egress node is the node where traffic leaves the ring. LSPs that have the same egress node on the ring and travel along the ring in the same direction (clockwise or anticlockwise) share the same ring tunnels. For each egress node, four ring tunnels are established:

- 1) one clockwise working ring tunnel, which is protected by the anticlockwise protection ring tunnel;
- 2) one anticlockwise protection ring tunnel;
- 3) one anticlockwise working ring tunnel, which is protected by the clockwise protection ring tunnel;
- 4) one clockwise protection ring tunnel.

The principle of the protection tunnels is determined by the selected protection mechanism (wrapping, short-wrapping, steering). This is described in subsequent clauses.

As shown in Figure A.2, LSP1, LSP2, and LSP3 enter the ring from node A, node E and node B, respectively, and all leave the ring at node D. To protect the LSPs that traverse the ring, a clockwise working ring tunnel (RcW_D) via E→F→A→B→C→D and its anticlockwise protection ring tunnel (RaP_D) via D→C→B→A→F→E→D are established. Also, an anticlockwise working ring tunnel (RaW_D) via C→B→A→F→E→D and its clockwise protection ring tunnel (RcP_D) via D→E→F→A→B→C→D are established. For simplicity, Figure A.2 only shows RcW_D and RaP_D. A similar provisioning should be applied for any other node on the ring. In summary, for each node in Figure A.2, when acting as an egress node, the ring tunnels are created as follows:

- 1) to node A: RcW_A, RaW_A, RcP_A, RaP_A;
- 2) to node B: RcW_B, RaW_B, RcP_B, RaP_B;
- 3) to node C: RcW_C, RaW_C, RcP_C, RaP_C;
- 4) to node D: RcW_D, RaW_D, RcP_D, RaP_D;
- 5) to node E: RcW_E, RaW_E, RcP_E, RaP_E;
- 6) to node F: RcW_F, RaW_F, RcP_F, RaP_F.

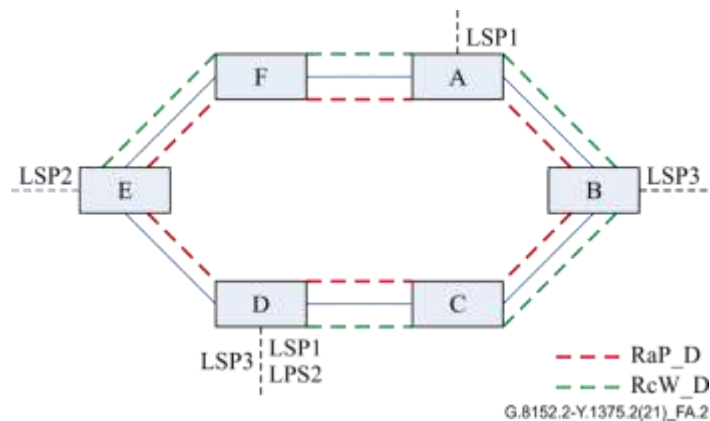

Figure A.2 – Ring tunnels in MSRP

Subsequent clauses specify the ring protection mechanisms in detail. In general, the description uses the clockwise working ring tunnel and the corresponding anticlockwise protection ring tunnel as an example, but the mechanism is applicable in the same way to the anticlockwise working and clockwise protection ring tunnels.

A.1 Wrapping

Figure A.3 is a view of a basic network. A signal passes from port 3 node A to port 3 node D. LSP1 is A-B-C-D.

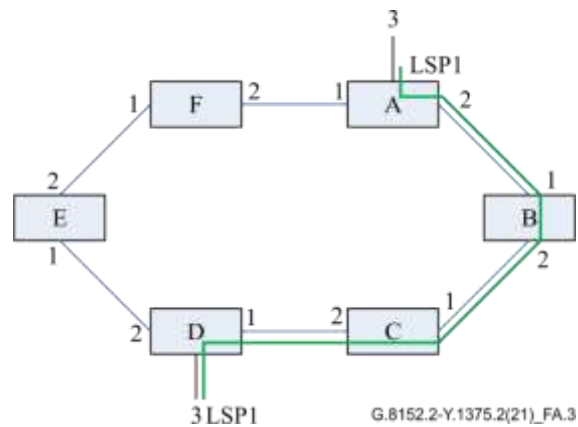

Figure A.3 – Basic network

When a link failure occurs between node B and node C, see Figure A.4. Node B switches the clockwise working ring tunnel to the anticlockwise protection ring tunnel, and sends a status message to node C along the ring away from the link failure, notifying node C to switch from the working tunnel to the corresponding protection tunnel. Then signal then follows the path A-B-A-F-E-D-C-D.

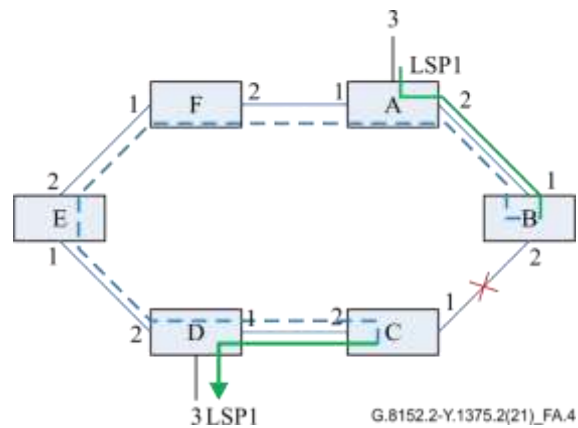

Figure A.4 – Wrapping for link failure

Figures A.5 to A.9 show the object classes (LTP and FC, FcSwitch, CASC) configurations for nodes in the ring under normal and failure condition.

Figure A.5 shows the configurations of node B and node C with the switches set to normal position. There is an actual FC that allows a signal to flow between the working ring tunnels.

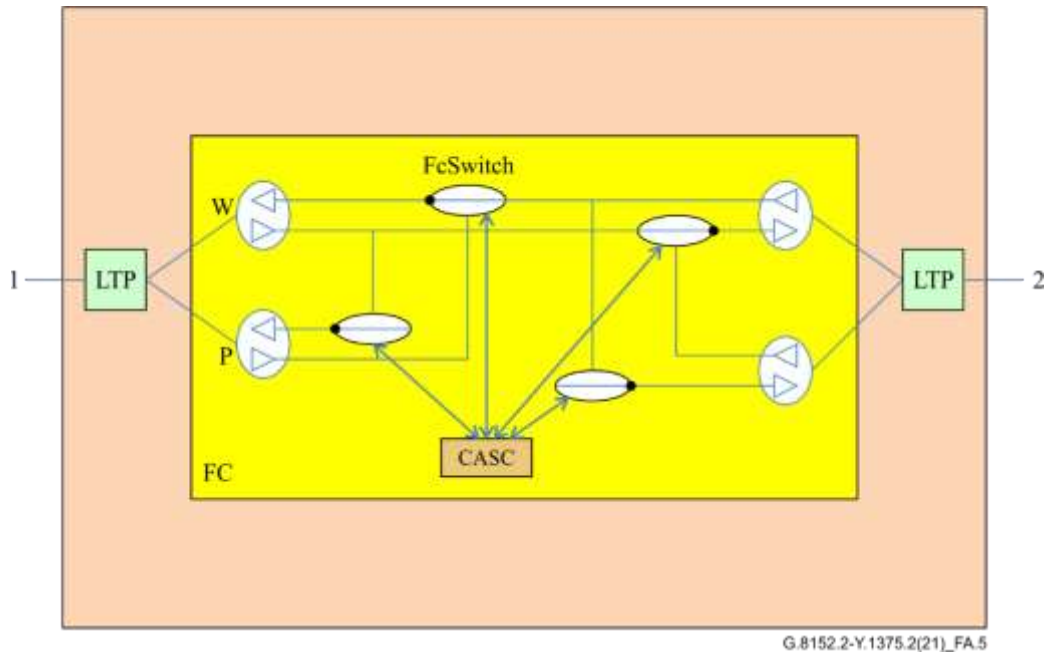

Figure A.5 – Wrapping: Node B and node C (no failure in ring)

Figure A.6 shows the configurations of node D with the switches set to normal position. There is an actual signal to flow between port 1 and port 3 on the working ring tunnel.

Note that node A has the same configuration, except that port 2 is used for normal signal flow and the protection faces port 1 not port 2.

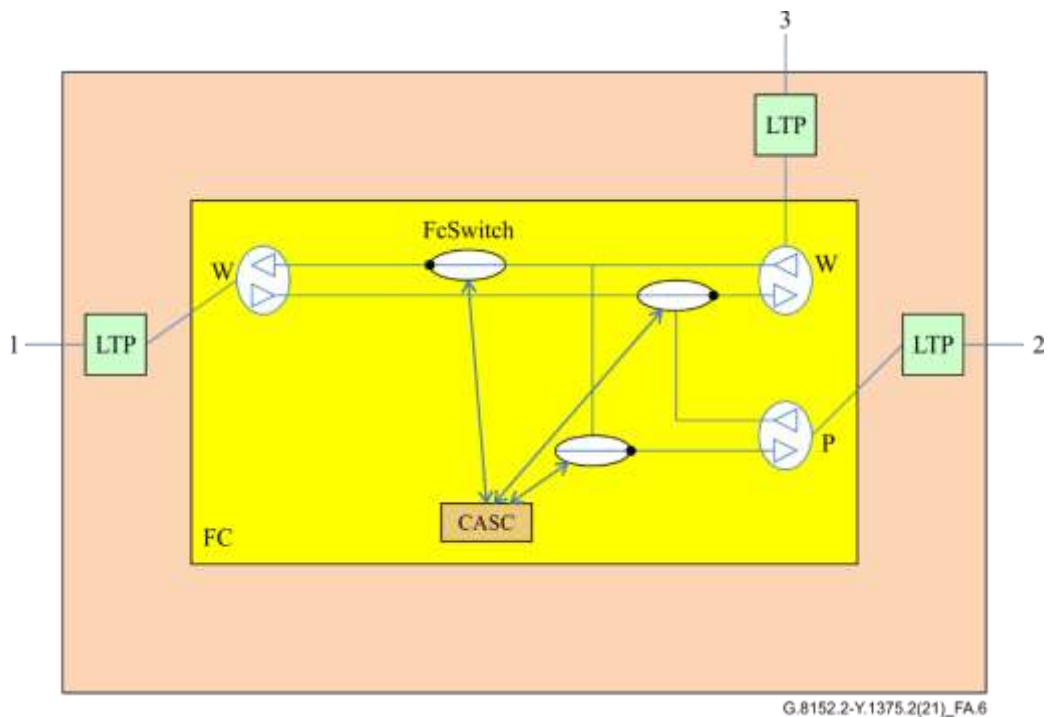

Figure A.6 – Wrapping: Node D (no failure in ring)

Figure A.7 shows the configurations of node B with a failure on link between node B and node C, such that the switches on port 1 have been set to the protection ring tunnel. The FC allows a signal to flow between the working and protection FcPort on port 1, such that the signal is wrapped back to port 1.

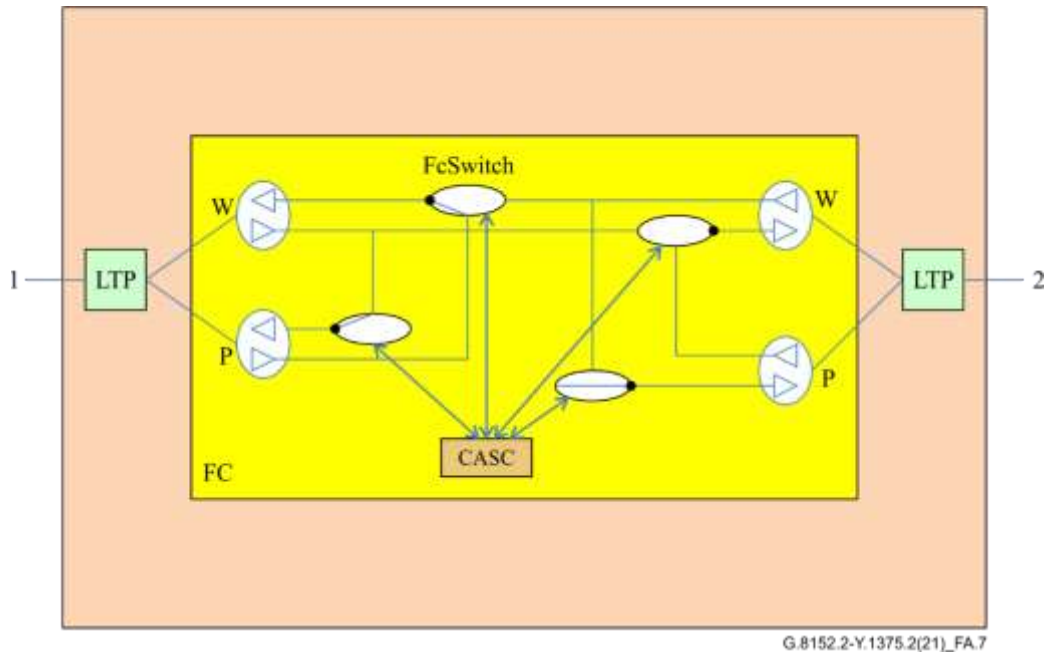

Figure A.7 – Wrapping: Node B with failure on link between node B and node C

Figure A.8 shows the configurations of node C with a failure on the link between node B and node C. It is the same as node B, except that in node C the switching position is on port 2.

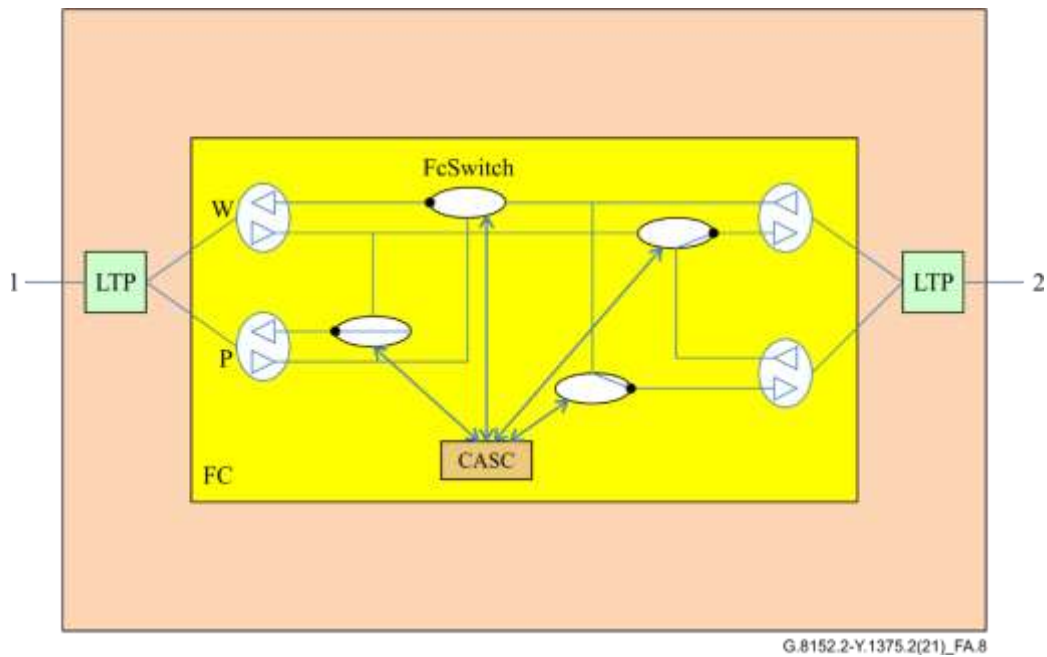

Figure A.8 – Wrapping: Node C with failure on link between node B and node C

Figure A.9 shows the configurations on node E and node F for a failure on the link between node B and node C. There is an actual FC that allows a signal to flow between the protection-ring tunnel on port 1 and port 2 due to the wrap in node B shown in Figure A.8.

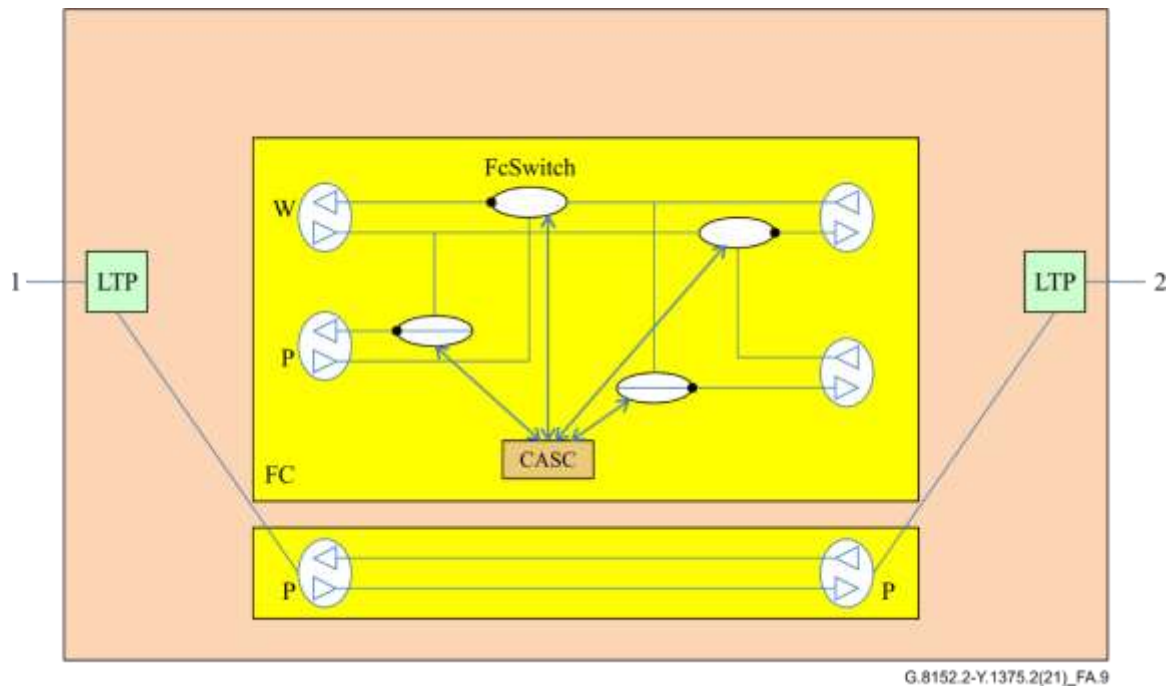

Figure A.9 – Wrapping: Node E and node F with failure on link between node B and node C

Node A and node D do not need to switch to the protection ring tunnel as node B and node C perform the protection function in this case. In general, for the wrapping scheme, the nodes on either side of the failure perform the protection function.

A.2 Steering

With the steering ring scheme, the ingress node switches from the working to the protection ring, and at the egress node, traffic leaves the ring from the protection ring tunnel.

Figure A.10 shows a view of the basic network. Figure A.10 is the same as Figure A.3. A signal passes from port 3 node A to port 3 node D. LSP1 is A-B-C-D.

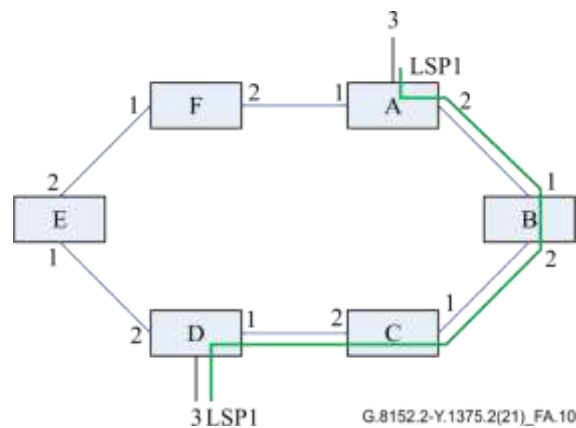

Figure A.10 – Basic network

When a link failure occurs between node B and node C, as shown in Figure A.11, node A switches the signal from the clockwise working ring tunnel to the anticlockwise protection ring tunnel, and leaves at node D on the protection ring tunnel. The signal then follows the path A-F-E-D.

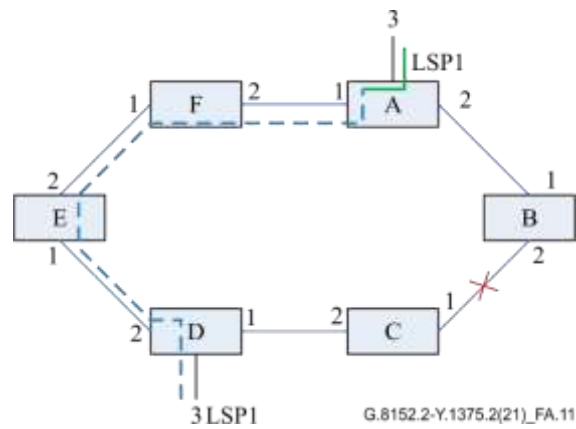

Figure A.11 – Steering for link failure

Figures A.12 to A.14 show the LTP and FC configurations for nodes in the ring under normal and failure conditions.

For the normal condition, the switches in nodes B, C, D and A are the same as in the wrapping situation shown in Figure A.5 and Figure A.6.

When there is a failure on link between node B and node C, the ring nodes may work as shown in Figures A.12 to A.14.

Figure A.12 shows the configurations of node D with a failure on the link between node B and node C, there is an actual FC that allows a signal to flow between the protection paths on port 2 and port 3.

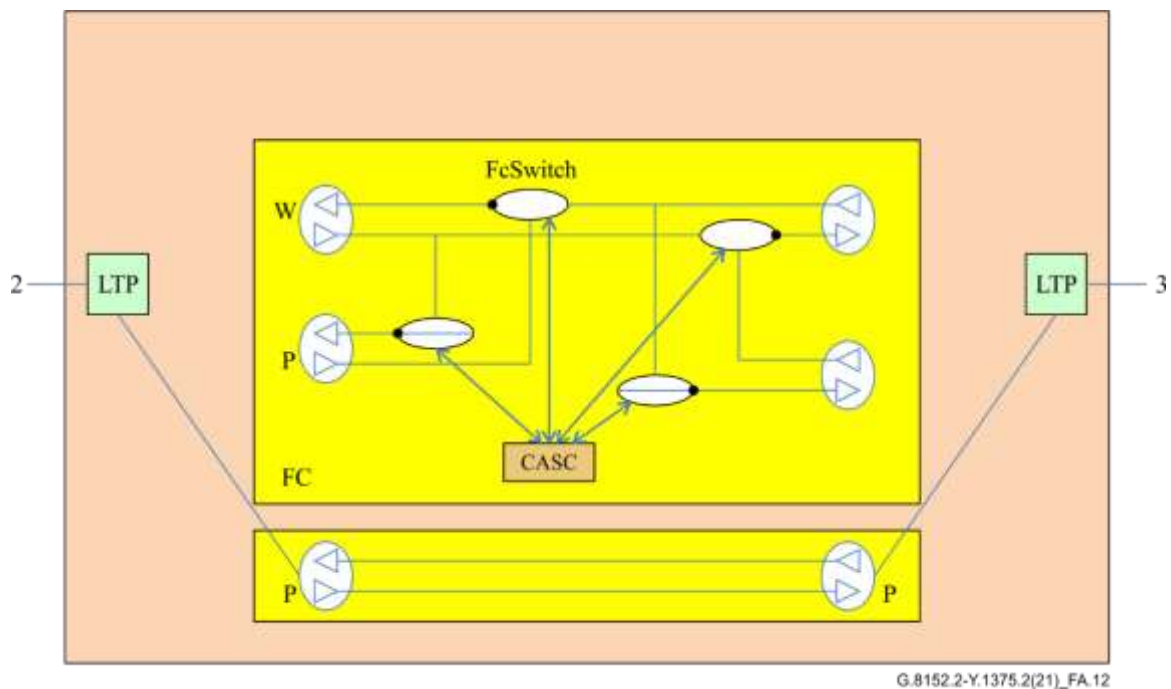

Figure A.12 – Steering: Node D with failure on link between node B and node C

Figure A.13 shows the configurations of node A with a failure on the link between node B and node C, such that the signal is switched to flow between protection port 1 and working port 3.

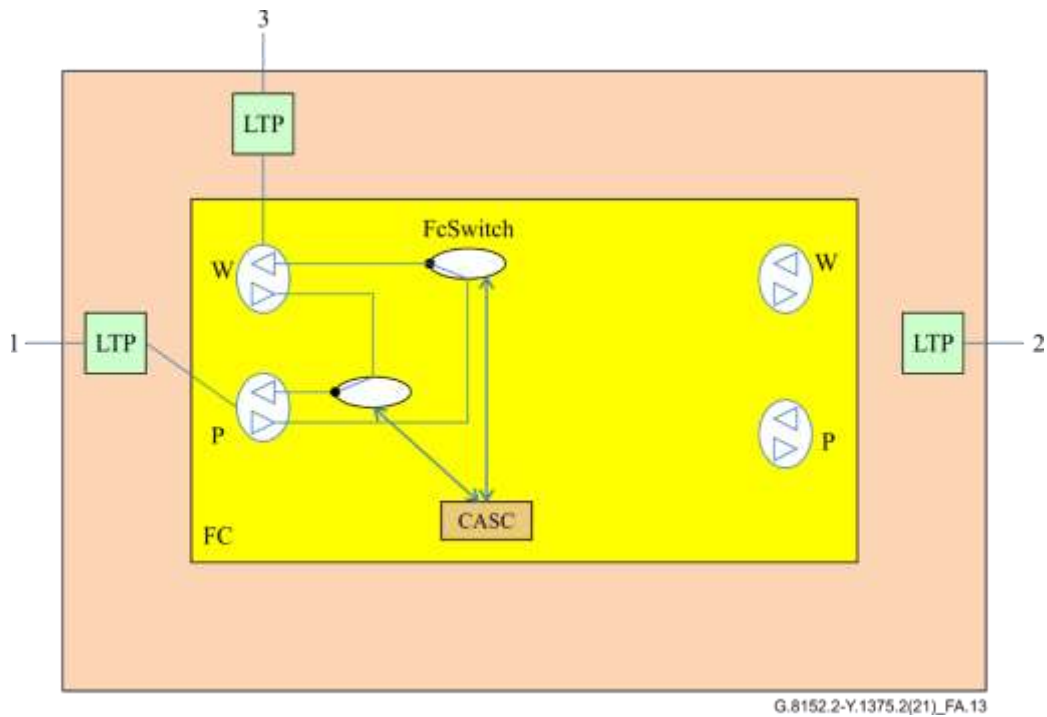

Figure A.13 – Steering: Node A with failure on link between node B and node C

Figure A.14 shows the configurations on node E and node F for a failure on the link between node B and node C. There is an actual FC that allows a signal to flow between the protection path on port 1 and port 2 due to the switching in node A shown in Figure A.13.

Node B and node C are not involved in the switching.

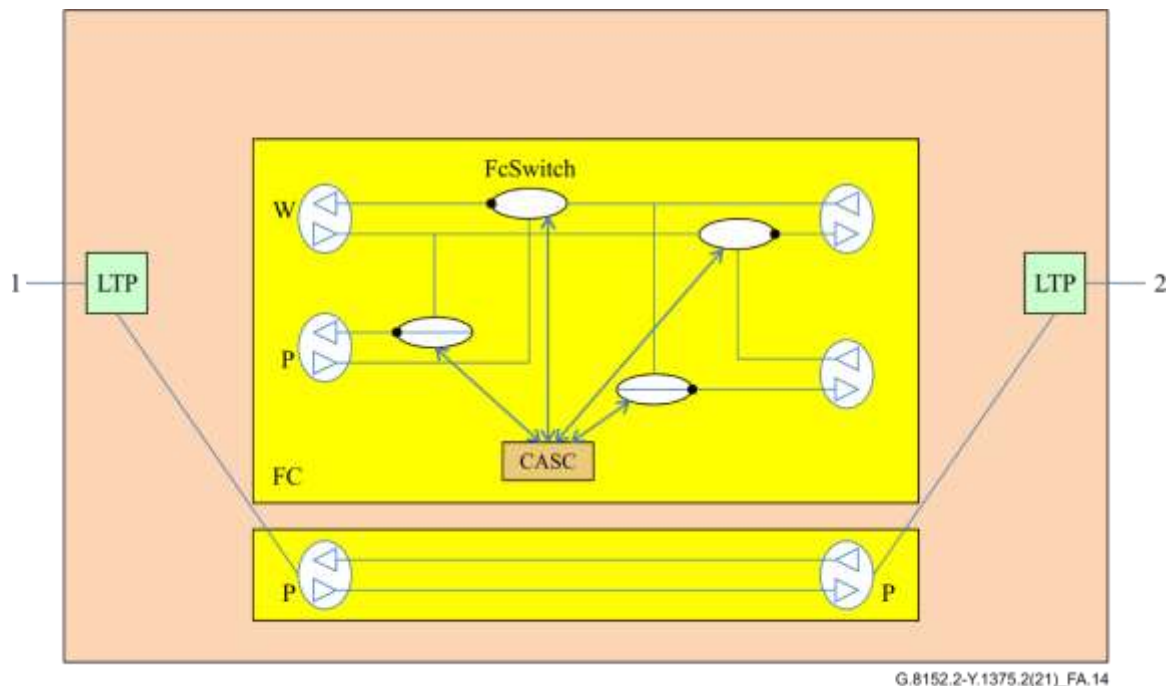

Figure A.14 – Steering: Node E and node F with failure on link between node B and node C

A.3 Short-wrapping

With the wrapping ring scheme, protection switching is executed at both nodes adjacent to the failure. However, with the short-wrapping ring scheme, protection switching is executed only at the node

upstream to the failure. Additionally, the packet leaves the protection ring at the egress end. Figure A.15 is a view of a basic network. Figure A.15 is the same as Figure A.3. A signal passes from port 3 node A to port 3 node D. LSP1 is A-B-C-D.

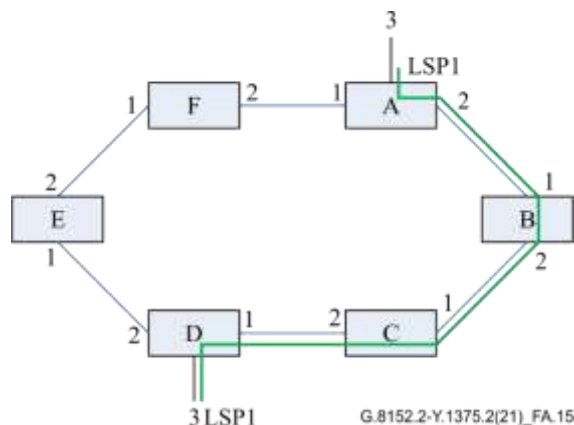

Figure A.15 – Basic network

When a link failure occurs between node B and node C, see Figure A.16. Node B switches the clockwise working ring tunnel to the anticlockwise protection ring tunnel, and leaves at node D on the protection ring tunnel. The signal then follows the path A-B-A-F-E-D.

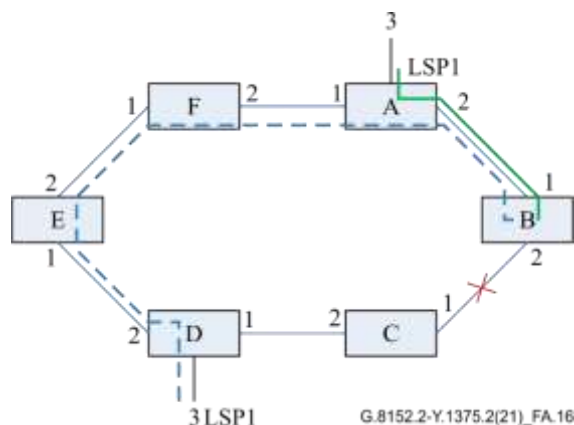

Figure A.16 – Short-wrapping for link failure

Figures A.17 to A.19 show the LTP and FC configurations for nodes in the ring under normal and failure conditions.

For the normal condition, the switches in nodes B, C, D and A are the same as in the wrapping situation shown in Figure A.5 and Figure A.6.

When there is a failure on the link between node B and node C, the nodes work as shown in Figures A.17 to A.19.

Figure A.17 shows the configurations of node B with a failure on the link between node B and node C, such that the switches on port 1 have been set to the protection path. The FC allows a signal to flow between the working and protection on port 1, such that the signal is wrapped back to port 1. For this node, the wrapping scheme is the same as that in Figure A.7.

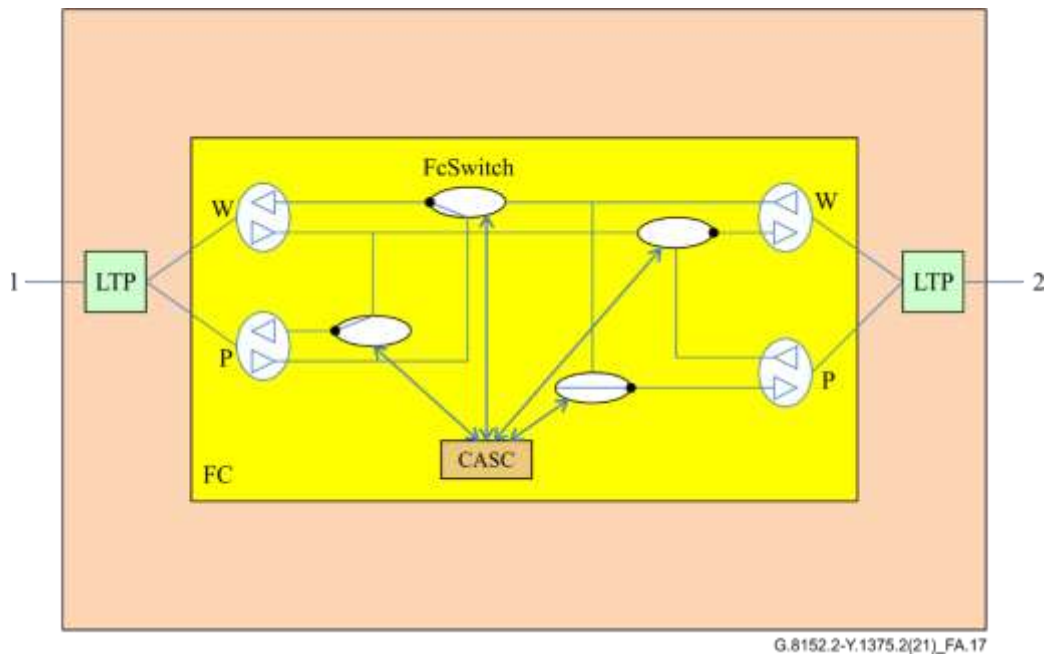

Figure A.17 – Wrapping: Node B with failure on link between node B and node C

Figure A.18 shows the configurations on node E and node F for a failure on the link between node B and node C. There is an actual FC that allows a signal to flow between the protection path on port 1 and port 2 due to the wrapping in node B as shown in Figure A.17.

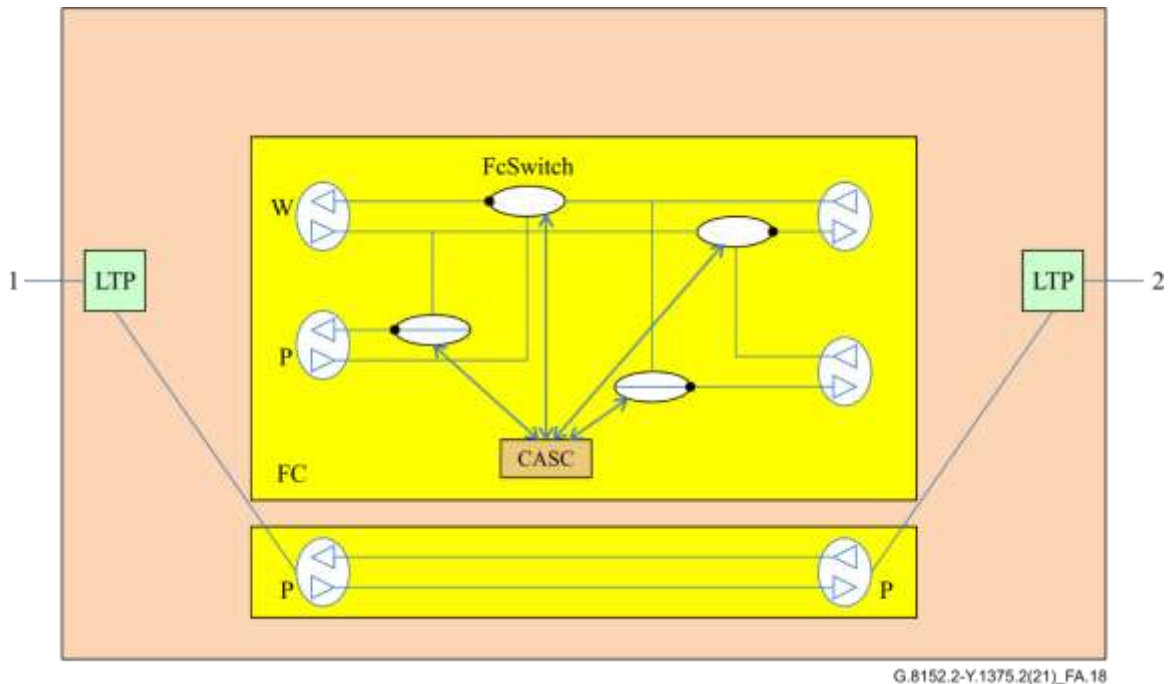

Figure A.18 – Short-wrapping: Node E and node F with failure on link between node B and node C

Figure A.19 shows the configurations on node D for a failure on the link between node B and node C. There is an actual FC that allows a signal to flow between the protection path on port 2 and port 3 due to the wrap in node B as shown in Figure A.18.

Node A does not need to switch as node B performs the protection function in this case. Node C is not included in this scheme because the signal leaves through node D. In general, for the short-wrapping scheme, only the node on the upstream side of the failure performs the protection function. However, the two directions of a protected bidirectional LSP are no longer co-routed under protection-switching conditions.

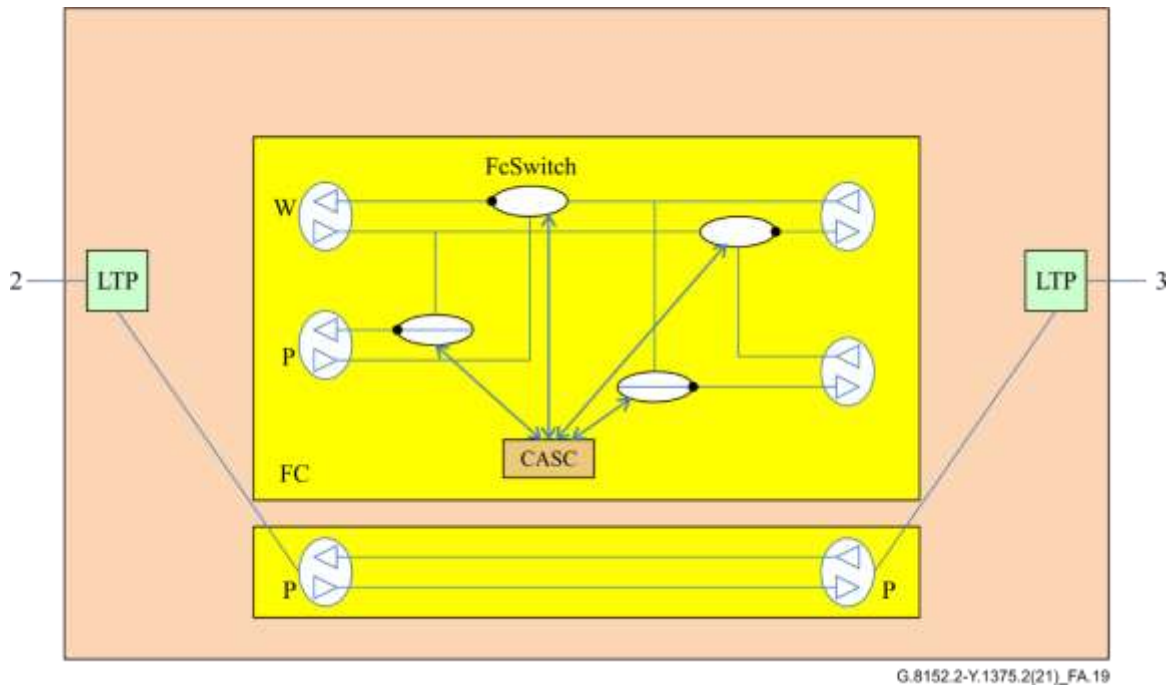

Figure A.19 – Short-wrapping: Node D with failure on the link between node B and node C

Appendix I

Linear protection examples

(This appendix does not form an integral part of this Recommendation.)

I.1 1+1/1:1 Cases

This clause deals with an MPLS-TP 1+1/1:1 protection group and shows how it can be represented.

Figure I.1 shows a simple example of a 1+1/1:1 case in a basic network with three NEs. Of course, this can be generalized to more NEs. The end-to-end FC is partitioned into subordinate constructs (via FcHasLowerLevelFcs). MPLS-TP SNC/S protection and trail protection can be represented by this common example.

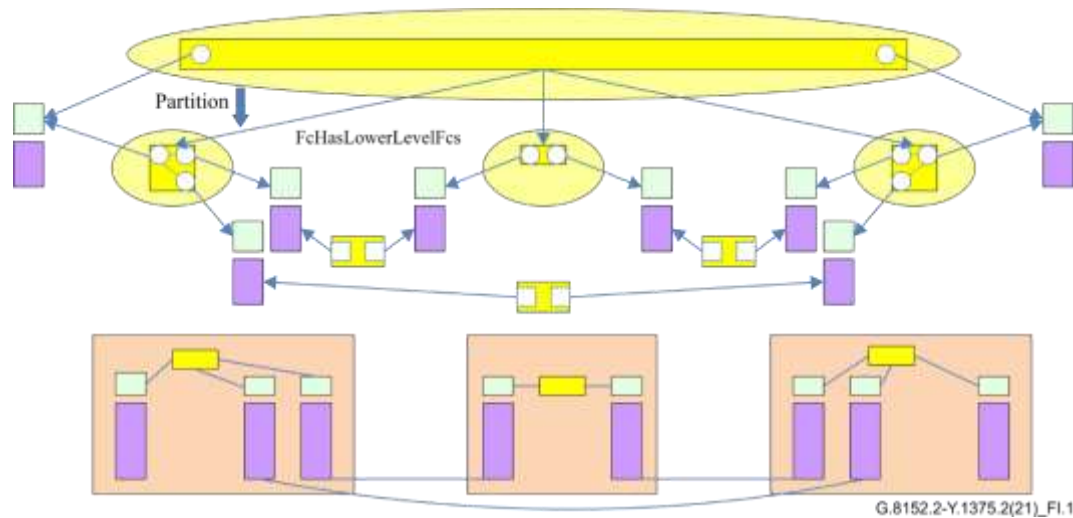

Figure I.1 – Simple example of linear 1+1/1:1 (from Figure XIV.1-1 of [ITU-T G.7711])

Figure I.2 shows a nodal view of 1+1 switches. It describes the ConfigurationAndSwitchControllers (CASC) encapsulated in the FC (upper part) and ConfigurationAndSwitchControllers encapsulated in the FcSwitch (lower part). The encapsulation type depends upon the scope of control of the CASC. The encapsulation is via FcSwitchCoordinatedByInternalControl when in the FcSwitch and FcSwitchesInFcCoordinatedBySwitchCoordinator when in the FC.

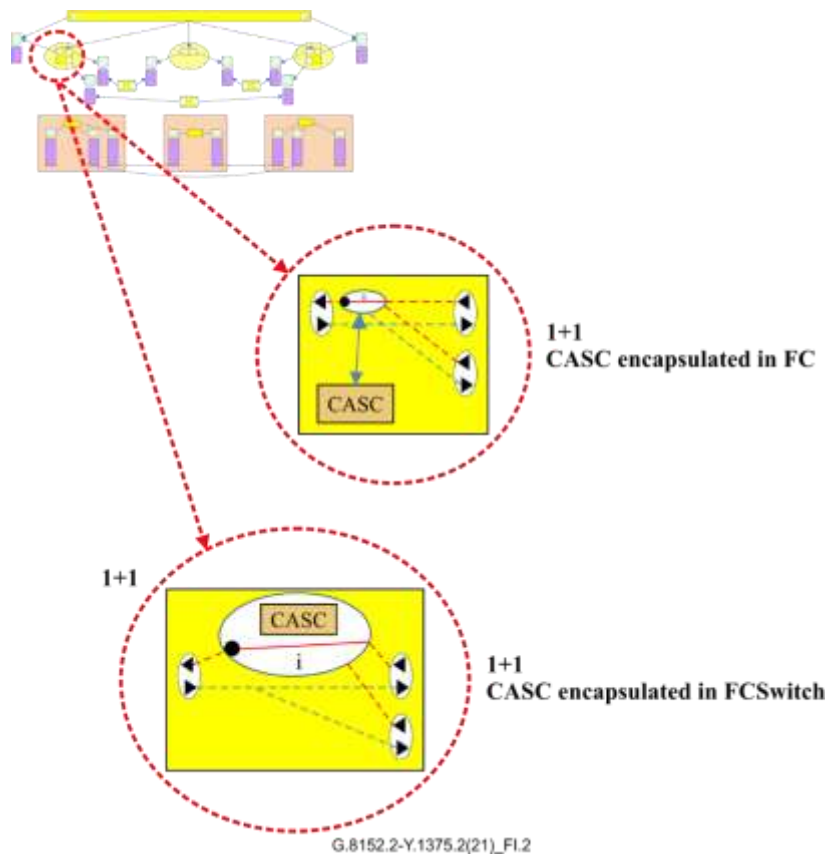

Figure I.2 – Detail of a nodal view of 1+1 switches

Figure I.3 shows a nodal view of 1:1 switches. It describes the ConfigurationAndSwitchControllers (CASC) encapsulated in the FC (upper part) and ConfigurationAndSwitchControllers encapsulated in the FcSwitch (lower part).

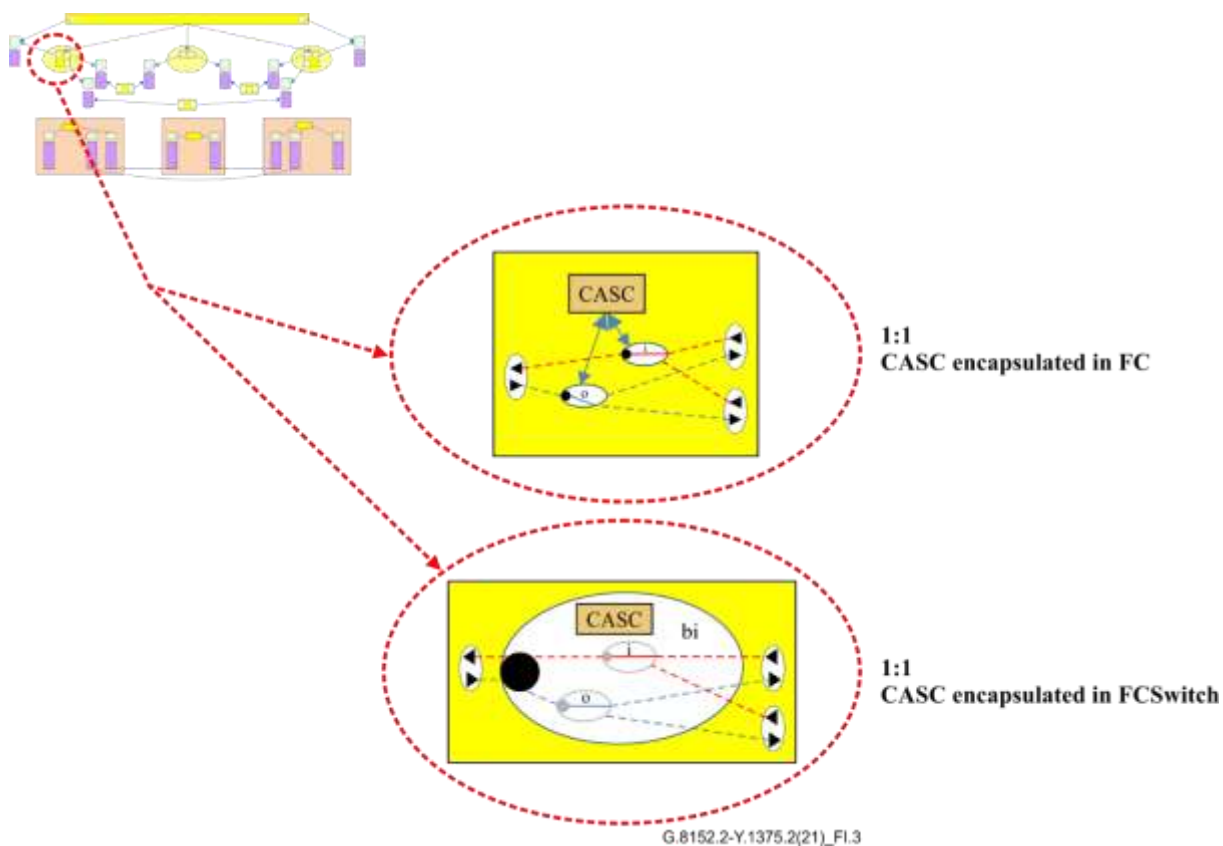

Figure I.3 – Detail of a nodal view of 1:1 switches

Figure I.4 shows a case of 1:1 independent switching, in which the two directions of traffic are switched independently. Figure I.4 assumes that the CASCs in the FCs at each end are distributed. It highlights a high-level CASC that can be used to collect common parameters, which should be set to the same values at both ends. In this case, the high level CASC governs the lower level CASC.

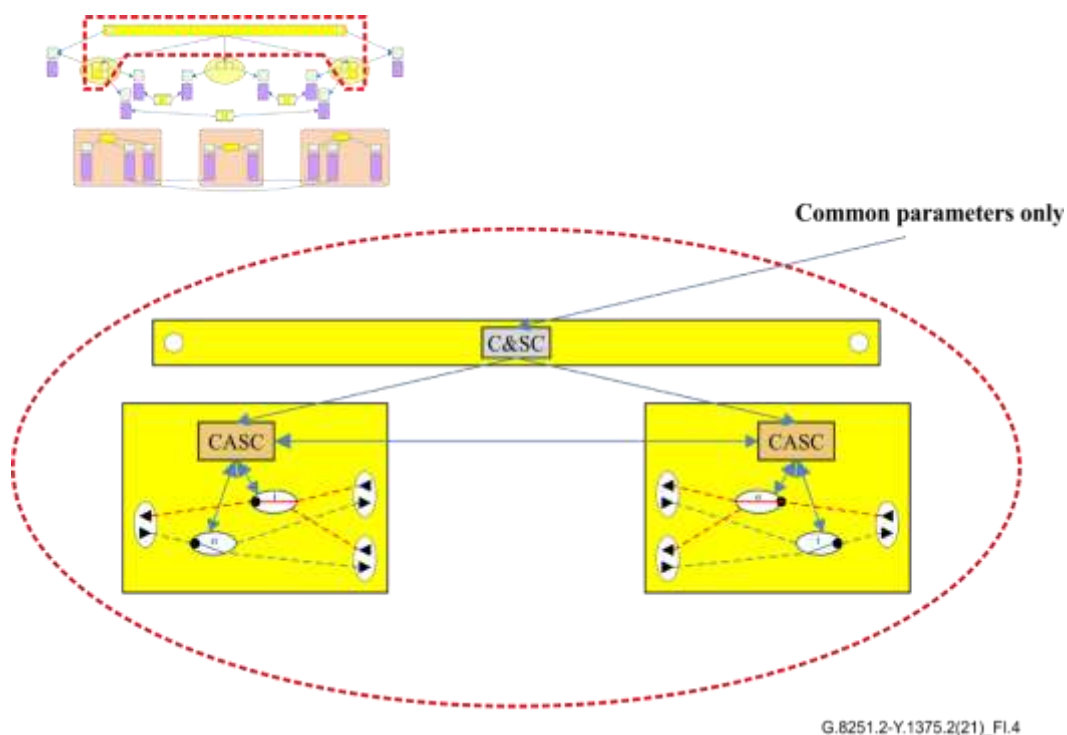

Figure I.4 – Showing a high-level abstract controller in a 1:1 case

Appendix II

Examples of using the IETF MPLS static lsp models to support MPLS-TP linear protection models

(This appendix does not form an integral part of this Recommendation.)

II.1 JSON examples

The following JSON codes are provided as examples of instances of the configuration and operational datastores of the YANG models defined in this appendix, together with the MPLS static LSP YANG model, under definition in [b-IETF-mpls-static] and MPLS-TP linear protection YANG model, defined in ITU-T G.8152.2, to support different operational scenarios, defined in clauses II.2 and II.3. The examples can be downloaded from: https://www.itu.int/ITU-T/formal-language/itu-t/g/g8152.2/2022/g8152.2_json-examples.zip.

II.2 MPLS-TP trail protection examples

Figure II.1 describes the reference network used to analyse the examples for MPLS-TP trail protection:

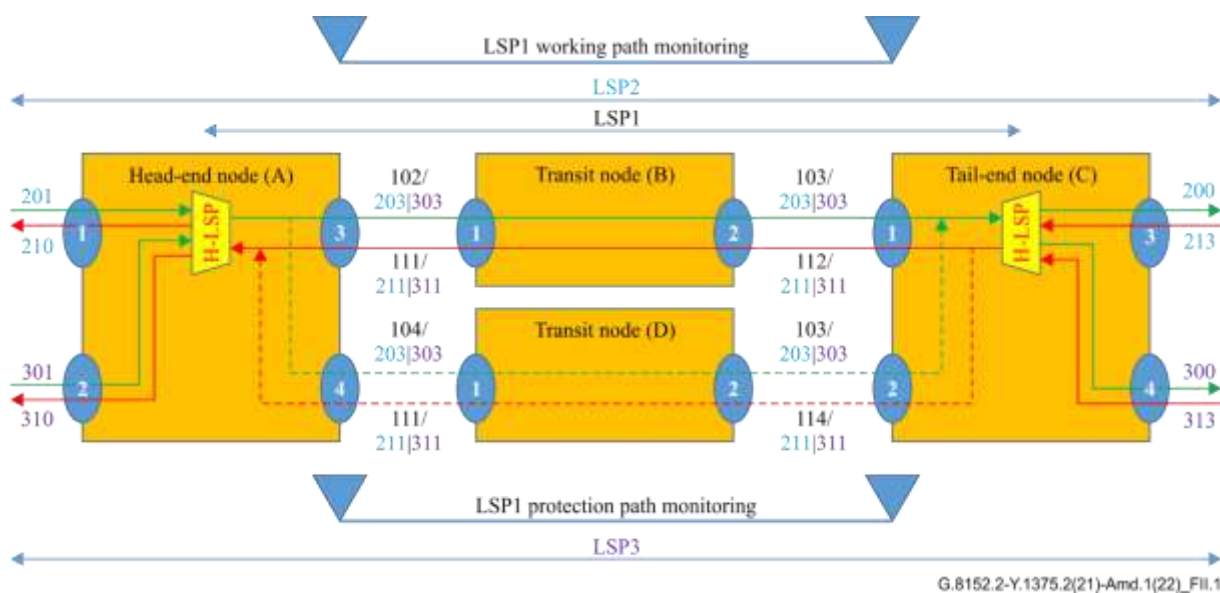

Figure II.1 – Example reference network for MPLS-TP trail protection

In this example, an MPLS-TP trail (i.e., LSP1) has been set up, with trail protection, between nodes A and C to be used as a server MPLS-TP sub-layer to carry two client MPLS-TP sub-network connections (i.e., LSP2 and LSP3).

The label values marked in black (e.g., 102) represent the label assigned to LSP1 on different links; the label values marked in cyan (e.g., 201) represent the label values assigned to LSP2 on different links, and the label values marked in magenta (e.g., 301) represent the label values assigned to LSP3 on different links. The convention 102/203|303 is used to represent the case where on the link packets are transmitted with a label stack having at the top of the stack label a label assigned to LSP1 (e.g., 102) and at the second position in the stack a label assigned to an LSP being carried over LSP1 (e.g., 102/203 for LSP2 over LSP1 packets and 102/303 for LSP3 over LSP1 packets).

It is worth noting that transit nodes for LSP1 (e.g., node B) forwards packets only based on the label at the top of the stack (used for LSP1); the second label in the stack is only used by the trail-end node

(e.g., node C) to decide how to forward the packet after the label at the top of the stack has been terminated.

II.2.1 Set-up of an MPLS-TP trail with trail protection

In this scenario, trail protection is configured during the set-up of the MPLS-TP trail (e.g., LSP1 in Figure II.1).

The start-up-state-node-a.json, start-up-state-node-b.json and start-up-state-node-c.json JSON codes show the initial applied configuration of the MPLS-TP node A, node B and node C within the reference network of Figure II.1. Other static LSPs, maintenance entity groups (MEGs) or linear protection groups, which are outside the scope of this example, may be present but not show in the start-up-state-node-a.json, start-up-state-node-b.json and start-up-state-node-c.json JSON codes.

In this scenario, the management and control system (MCS) should perform the following configuration on nodes A, B and C:

- Configure the MPLS-TP linear protection used to protect LSP1;
- Configure the MPLS-TP maintenance domains (MDs) and MAs:
 - Configure MPLS-TP MD and MD used to monitor LSP1 working path;
 - Configure MPLS-TP MD and MD used to monitor LSP1 protection path;
- Configure static LSP1:
 - Configure bidirectional static LSP1;
 - Configure reverse static LSP1;
 - Configure forward static LSP1

The trail-protection-config-node-a.json, trail-protection-config-node-c.json, trail-protection-config-node-b.json and trail-protection-config-node-d.json JSON codes show the complete configuration that the MCS should provide on the MPLS-TP nodes A, B, C and D within the reference network of Figure II.1, to set up the MPLS-TP trail LSP1 with trail protection, together with its client MPLS-TP sub-network connections LSP2 and LSP3.

The location of the down network connection monitoring (NCM) maintenance entity group end points (MEPs) and maintenance entity group intermediate points (MIPs) for the working and protection LSP shall be configured by the MCS and this configuration shall be consistent with the LSP1 forwarding configuration.

The trail-protection-state-node-a.json, trail-protection-state-node-c.json, trail-protection-state-node-b.json and trail-protection-state-node-d.json JSON codes show the corresponding applied configuration.

II.2.2 Add trail protection on existing MPLS-TP trail

In this scenario, trail protection is added after the MPLS-TP trail (e.g., LSP1 in Figure II.1) has been set up. Trail monitoring may be configured on the existing MPLS-TP trail.

The trail-setup-state-node-a.json, trail-setup-state-node-b.json and trail-setup-state-node-c.json JSON codes show the initial applied configuration of the MPLS-TP nodes A, B and C within the reference network of Figure II.1: in this configuration, MPLS-TP trail LSP1 has been set up, without trail monitoring, together with its client MPLS-TP sub-network connections LSP2 and LSP3.

In this scenario, the MCS should perform the following configuration on nodes A, B and C:

- Configure the MPLS-TP linear protection used to protect LSP1;
- Configure MPLS-TP MDs and MAs:
 - Configure the MPLS-TP MD and MD used to monitor LSP1 working path, if not already present;

- o Configure the MPLS-TP MD and MD used to monitor LSP1 protection path;
- Re-configure static LSP1:
 - o Reconfigure backward static LSP1 to accept packets from any interface;
 - o Reconfigure forward static LSP1 with primary and backup next hop label forwarding entries (NHLFEs);
- Re-configure static LSP2 and LSP3:
 - o Reconfigure backward static LSP2 and LSP3 to accept packets from any interface;
 - o Reconfigure forward static LSP2 and LSP3 with primary and backup NHLFEs

It is worth noting that adding MPLS-TP trail protection to an existing MPLS-TP trail (e.g., LSP1) requires changing its forwarding configuration as well as the configuration of its client MPLS-TP SNCs (e.g., LSP2 and LSP3).

The tail-protection-config-node-a.json, tail-protection-config-node-b.json, tail-protection-config-node-d.json and tail-protection-config-node-c.json JSON codes show the complete configuration that the MCS should provide on the MPLS-TP nodes A, B, C and D within the reference network of Figure II.1, to add MPLS-TP trail protection to the existing MPLS-TP trail LSP1.

The trail-protection-state-node-a.json, trail-protection-state-node-b.json, trail-protection-state-node-d.json and trail-protection-state-node-c.json JSON codes show the corresponding applied configuration.

II.2.3 Remove trail monitoring keeping the working path

In this scenario, trail protection is removed but the MPLS-TP trail (e.g., LSP1 in Figure II.1) is not removed and its working path is used after trail protection is removed. Trail monitoring may also be removed.

The trail-protection-state-node-a.json, trail-protection-state-node-b.json, trail-protection-state-node-d.json and trail-protection-state-node-c.json JSON codes show the initial applied configuration of the MPLS-TP node A, B, C, D within the reference network of Figure II.1.

In this scenario, the MCS should perform the following configuration on the head-end node A, B, C and D:

- Re-configure static LSP2 and LSP3:
 - o Reconfigure backward static LSP2 and LSP3 to accept packets only from the interface on the working path;
 - o Reconfigure forward static LSP2 and LSP3 to use only the NHLFE of the primary path;
- Re-configure static LSP1:
 - o Reconfigure backward static LSP1 to accept packets only from the interface on the working path;
 - o Reconfigure forward static LSP1 to use only the NHLFE of the primary path;
- Remove MPLS-TP MDs and MAs:
 - o Remove the MPLS-TP MD and MD used to monitor LSP1 protection path;
 - o Optionally, remove the MPLS-TP MD and MD used to monitor LSP1 working path;
- Remove the MPLS-TP linear protection used to protect LSP1.

It is worth noting that removing MPLS-TP trail protection from an MPLS-TP trail (e.g., LSP1) requires changing its forwarding configuration as well as the configuration of its client MPLS-TP SNCs (e.g., LSP2 and LSP3).

The trail-setup-config-node-a.json, trail-setup-config-node-b.json and trail-setup-config-node-c.json JSON codes show the complete configuration that the MCS should provide on the MPLS-TP node

A, B and C within the reference network of Figure II.1 to remove MPLS-TP trail protection and trail monitoring from the existing MPLS-TP trail LSP1, keeping the working path. There is no configuration on node D after removing the trail protection and only keeping the working path.

The trail-setup-state-node-a.json, trail-setup-state-node-b.json and trail-setup-state-node-c.json JSON codes show the corresponding applied configuration.

II.3 MPLS-TP sub-network protection (SNC/S) examples

Figure II.2 describes the reference network used to analyse the examples for MPLS-TP sub-network protection (SNC/S):

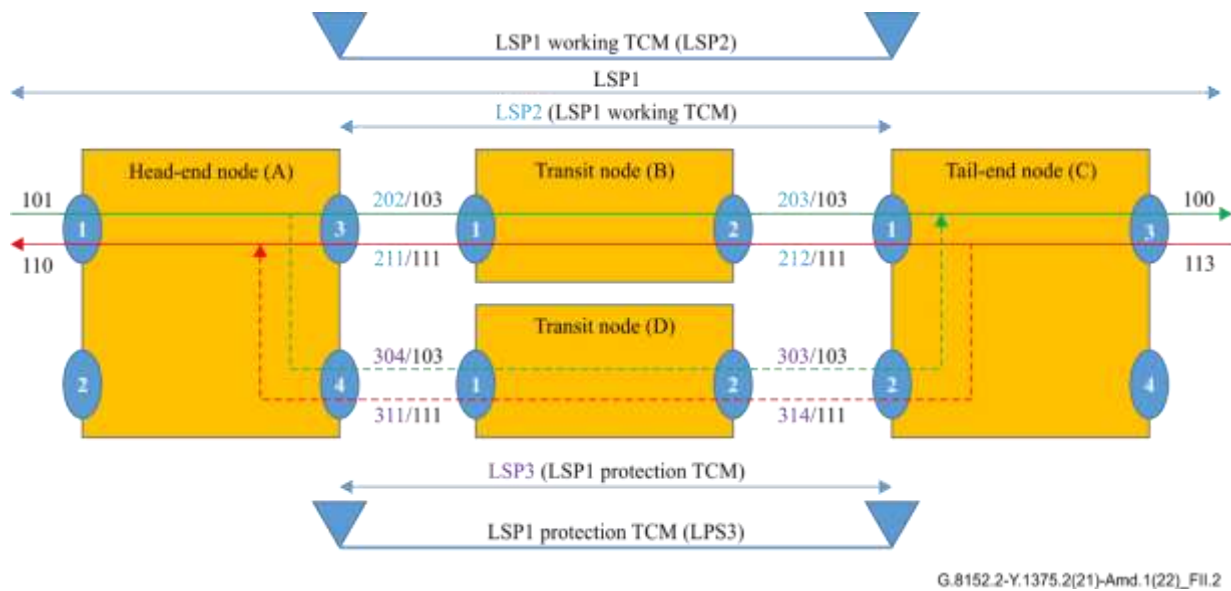

G.8152.2-Y.1375.2(21)-Amd.1(22)_FII.2

Figure II.2 – Example reference network for MPLS-TP SNC/S

II.3.1 Set-up of an MPLS-TP SNC with SNC/S protection

In this scenario, SNC/S is configured during the set-up of the MPLS-TP SNC (e.g., LSP1 in Figure II.2).

The start-up-state-node-a.json, start-up-state-node-b.json, start-up-state-node-d.json and start-up-state-node-c.json JSON codes show the initial applied configuration of the MPLS-TP node A within the reference network of Figure II.2.

Other static LSPs, MEGs or linear protection groups, which are outside the scope of this example, may be present but not show in the start-up-state-node-a.json, start-up-state-node-b.json, start-up-state-node-d.json and start-up-state-node-c.json JSON codes.

In this scenario, the MCS should perform the following configuration on the head-end node A, B, C and D:

- Configure the MPLS-TP linear protection used to protect LSP1;
- Configure the MPLS-TP MDs and MAs:
 - Configure MPLS-TP MD and MD used to monitor LSP2 (working path);
 - Configure MPLS-TP MD and MD used to monitor LSP3 (protection path);
- Configure static LSP2:
 - Configure bidirectional static LSP2;
 - Configure reverse static LSP2;
 - Configure forward static LSP2

- Configure static LSP3:
 - Configure bidirectional static LSP2;
 - Configure reverse static LSP2;
 - Configure forward static LSP2
- Configure static LSP1:
 - Configure bidirectional static LSP1;
 - Configure reverse static LSP1;
 - Configure forward static LSP1

The snc-protection-config-node-a.json, snc-protection-config-node-b.json, snc-protection-config-node-d.json and snc-protection-config-node-c.json JSON codes show the complete configuration that the MCS should provide on the MPLS-TP node A within the reference network of Figure II.2, to set up the MPLS-TP SNC LSP1, with SNC/S protection.

The location of the down tandem connection monitoring (TCM) MEPs on node A and node C for the working and protection LSPs can be inferred from the LSP2 and LSP3 forwarding configuration, and therefore their configuration is optional. The example in snc-protection-config-node-a.json and snc-protection-config-node-c.json JSON codes describe the case where the MCS does not explicitly configure this information.

The location of the in/out MIPs for the working and protection LSPs on node B and node D shall be configured by the MCS and this configuration shall be consistent with the LSP2 and LSP3 forwarding configuration. The example in snc-protection-config-node-b.json and snc-protection-config-node-d.json JSON codes describe the case where the MCS configures this information.

The snc-protection-state-node-a.json, snc-protection-state-node-b.json, snc-protection-state-node-d.json and snc-protection-state-node-c.json JSON codes show the corresponding applied configuration. It is worth noting that the location of the down TCM MEPs of LSP2 and LP3 are reported in the operational datastore, as required by the NMDA architecture in [IETF RFC 8342].

II.3.2 Add SNC/S protection on existing MPLS-TP SNC

In this scenario, SNC/S protection is added after the MPLS-TP SNC (e.g., LSP1 in Figure II.2) has been set up. TCM may be configured on the existing MPLS-TP SNC.

The snc-setup-state-node-a.json, snc-setup-state-node-b.json, snc-setup-state-node-d.json and snc-setup-state-node-c.json JSON codes show the initial applied configuration of the MPLS-TP node A, B, C and D within the reference network of Figure II.2: in this configuration, MPLS-TP SNC LSP1 is set up without TCM, and therefore also without the hierarchical LSP used for TCM OAM (e.g., LSP2).

In this scenario, the MCS should perform the following configuration on nodes A, B, C and D:

- Configure the MPLS-TP linear protection used to protect LSP1;
- Configure MPLS-TP MDs and MAs:
 - Configure the MPLS-TP MD and MD used to monitor LSP2 (working path), if not already present;
 - Configure the MPLS-TP MD and MD used to monitor LSP3 (protection path);
- Configure static LSP2, if not already present:
 - Configure bidirectional static LSP2;
 - Configure reverse static LSP2;
 - Configure forward static LSP2
- Configure static LSP3:

- o [Configure bidirectional static LSP3;](#)
- o [Configure reverse static LSP3;](#)
- o [Configure forward static LSP3](#)
- [Re-configure static LSP1:](#)
 - o [Reconfigure backward static LSP1 to accept packets from any interface;](#)
 - o [Reconfigure forward static LSP1 with primary and backup NHLFEs.](#)

[It is worth noting that adding MPLS-TP SNC/S protection to an existing MPLS-TP SNC \(e.g., LSP1\) requires changing its forwarding configuration.](#)

[The snc-protection-config-node-a.json, snc-protection-config-node-b.json, snc-protection-config-node-d.json and snc-protection-config-node-c.json JSON codes show the complete configuration that the MCS should provide on the MPLS-TP node A within the reference network of Figure II.2, to add MPLS-TP SNC/S protection to the existing MPLS-TP SNC LSP1.](#)

[The location of the down TCM MEPs for the working and protection LSPs can be inferred from the LSP2 and LSP3 forwarding configuration, and therefore their configuration is optional. The example in snc-protection-config-node-a.json and snc-protection-config-node-c.json JSON codes describe the case where the MCS does not explicitly configure this information.](#)

[The location of the in/out MIPs for the working and protection LSPs on node B and node D shall be configured by the MCS and this configuration shall be consistent with the LSP2 and LSP3 forwarding configuration. The example in snc-protection-config-node-b.json and snc-protection-config-node-d.json JSON describe the case where the MCS configures this information.](#)

[The snc-protection-state-node-a.json, snc-protection-state-node-b.json, snc-protection-state-node-d.json and snc-protection-state-node-c.json JSON codes show the corresponding applied configuration.](#)

II.3.3 Remove SNC/S protection keeping the working path

[In this scenario, SNC/S protection is removed but the MPLS-TP SNC \(e.g., LSP1 in Figure II.2\) is not removed and its working path is used after SNC/S protection is removed. TCM may also be removed.](#)

[The snc-protection-state-node-a.json, snc-protection-state-node-b.json, snc-protection-state-node-d.json and snc-protection-state-node-c.json JSON codes show the initial applied configuration of the MPLS-TP nodes A, B, C and D within the reference network of Figure II.2.](#)

[In this scenario, the MCS should perform the following configuration on nodes A, B, C and D:](#)

- [Re-configure static LSP1:](#)
 - o [Reconfigure backward static LSP1 to accept packets only from the interface on the working path;](#)
 - o [Reconfigure forward static LSP1 to use only the NHLFE of the primary path;](#)
- [Remove static LSP3:](#)
 - o [Remove forward static LSP3;](#)
 - o [Remove reverse static LSP3;](#)
 - o [Remove bidirectional static LSP3;](#)
- [Optionally, remove static LSP2:](#)
 - o [Remove forward static LSP2;](#)
 - o [Remove reverse static LSP2;](#)
 - o [Remove bidirectional static LSP2;](#)

- Remove MPLS-TP MDs and MAs:
 - Remove the MPLS-TP MD and MD used to monitor LSP3 (protection path);
 - Optionally remove the MPLS-TP MD and MD used to monitor LSP2 (working path);
- Remove the MPLS-TP linear protection used to protect LSP1

It is worth noting that removing MPLS-TP SNC/S protection from an existing MPLS-TP SNC (e.g., LSP1) requires changing its forwarding configuration.

The snc-setup-config-node-a.json, snc-setup-config-node-b.json and snc-setup-config-node-c.json JSON code shows the complete configuration that the MCS should provide on the MPLS-TP nodes A, B and C within the reference network of Figure II.2 to remove MPLS-TP SNC/S protection and TCM from the existing MPLS-TP SNC LSP1, keeping the working path.

The snc-setup-state-node-a.json, snc-setup-state-node-b.json and snc-setup-state-node-c.json JSON codes show the corresponding applied configuration.

Appendix III

Relationship between the MPLS-TP linear protection and the reverse-engineered IETF MPLS static UML model

(This appendix does not form an integral part of this Recommendation.)

For the [ITU-T G.8131] MPLS-TP linear protection to be supported in the MPLS-TP network, the working and protection transport entities need to be associated with the forwarding plane of the MPLS-TP network.

Since the MPLS-TP linear protection YANG model defined in this Recommendation references to the [IETF RFC8531] connection-oriented OAM Ma object class, to configure the MEGs used to monitor the working and protection transport entities, the association of the MPLS-TP linear protection with the forwarding plane is inherited from the association of the Ma of the working and protection Ma with the forwarding plane. The MA needs to reference the bidirectional LSP used to generate and receive MPLS packets, in case of trail protection, this bidirectional LSP is also the monitored LSP; in case of TCM, this bidirectional LSP is the referenced LSP (different referenced LSPs are used to monitor the working path and protection path).

Thus, in the case IETF mpls static is deployed in the MPLS network, the MEPs on the working and protection transport entities need to refer to the MEP position. If the referenced LSP and the MEP type (up/down) is not sufficient to locate the MEP position, e.g., in case of trail protection, the MEP shall also reference the interface of the IETF mpls static to indicate where it is located.

Figure 7-3 in [ITU-T G.8152.1] shows the relationship between MA/MEP/MIP and reverse-engineered IETF MPLS static and interface UML models.

The relationship between MPLS-TP linear protection and Nhlfe-Multiple in IETF mpls static is as given in Figure III.1. The linear protection group controls the switching state of this NHLFE through the `_localId` (in `linearprotection` object class) attribute.



Figure III.1 – Relationship between mpls-tp-linear-protection and IETF mpls static

Bibliography

- ~~[b-IETF-mpls-base]~~ — MPLS Working Group, Internet draft, version 17 (October 2020), *A YANG data model for MPLS base: draft ietf mpls base yang 17* (work in progress). Available [viewed 2021-04-16] at: <https://tools.ietf.org/html/draft-ietf-mpls-base-yang-17>
- ~~[b-IETF-mpls-static]~~ — MPLS Working Group, Internet draft, version 12-13 (April-July 2020-2021), *A YANG data model for MPLS static LSPs: draft-ietf-mpls-static-yang-113* (work in progress). Available [viewed 2021-04-16/27] at: <https://tools.ietf.org/html/draft-ietf-mplsstatic-yang-113>
- [b-IETF-mpls-static] — MPLS Working Group, Internet draft, version 13 (July 2021), *A YANG data model for MPLS static LSPs: draft ietf mpls static yang 13* (work in progress). Available [viewed 2021-7-27] at: <https://datatracker.ietf.org/doc/draft-ietf-mpls-static-yang/>.
- [b-ONF TR-531] — Technical Recommendation ONF TR-531 v1.1-info (2018), *UML to YANG mapping guidelines*. Available [viewed 2021-04-16] at: https://onfstaging1.opennetworking.org/wp-content/uploads/2018/08/TR-531_UML-YANG_Mapping_Gdls_v1.1-1-1.pdf.

ITU-T Y-SERIES RECOMMENDATIONS

GLOBAL INFORMATION INFRASTRUCTURE, INTERNET PROTOCOL ASPECTS, NEXT-GENERATION NETWORKS, INTERNET OF THINGS AND SMART CITIES

GLOBAL INFORMATION INFRASTRUCTURE	
General	Y.100–Y.199
Services, applications and middleware	Y.200–Y.299
Network aspects	Y.300–Y.399
Interfaces and protocols	Y.400–Y.499
Numbering, addressing and naming	Y.500–Y.599
Operation, administration and maintenance	Y.600–Y.699
Security	Y.700–Y.799
Performances	Y.800–Y.899
INTERNET PROTOCOL ASPECTS	
General	Y.1000–Y.1099
Services and applications	Y.1100–Y.1199
Architecture, access, network capabilities and resource management	Y.1200–Y.1299
Transport	Y.1300–Y.1399
Interworking	Y.1400–Y.1499
Quality of service and network performance	Y.1500–Y.1599
Signalling	Y.1600–Y.1699
Operation, administration and maintenance	Y.1700–Y.1799
Charging	Y.1800–Y.1899
IPTV over NGN	Y.1900–Y.1999
NEXT GENERATION NETWORKS	
Frameworks and functional architecture models	Y.2000–Y.2099
Quality of Service and performance	Y.2100–Y.2199
Service aspects: Service capabilities and service architecture	Y.2200–Y.2249
Service aspects: Interoperability of services and networks in NGN	Y.2250–Y.2299
Enhancements to NGN	Y.2300–Y.2399
Network management	Y.2400–Y.2499
Computing power networks	Y.2500–Y.2599
Packet-based Networks	Y.2600–Y.2699
Security	Y.2700–Y.2799
Generalized mobility	Y.2800–Y.2899
Carrier grade open environment	Y.2900–Y.2999
FUTURE NETWORKS	Y.3000–Y.3499
CLOUD COMPUTING	Y.3500–Y.3599
BIG DATA	Y.3600–Y.3799
QUANTUM KEY DISTRIBUTION NETWORKS	Y.3800–Y.3999
INTERNET OF THINGS AND SMART CITIES AND COMMUNITIES	
General	Y.4000–Y.4049
Definitions and terminologies	Y.4050–Y.4099
Requirements and use cases	Y.4100–Y.4249
Infrastructure, connectivity and networks	Y.4250–Y.4399
Frameworks, architectures and protocols	Y.4400–Y.4549
Services, applications, computation and data processing	Y.4550–Y.4699
Management, control and performance	Y.4700–Y.4799
Identification and security	Y.4800–Y.4899
Evaluation and assessment	Y.4900–Y.4999

For further details, please refer to the list of ITU-T Recommendations.

SERIES OF ITU-T RECOMMENDATIONS

Series A	Organization of the work of ITU-T
Series D	Tariff and accounting principles and international telecommunication/ICT economic and policy issues
Series E	Overall network operation, telephone service, service operation and human factors
Series F	Non-telephone telecommunication services
Series G	Transmission systems and media, digital systems and networks
Series H	Audiovisual and multimedia systems
Series I	Integrated services digital network
Series J	Cable networks and transmission of television, sound programme and other multimedia signals
Series K	Protection against interference
Series L	Environment and ICTs, climate change, e-waste, energy efficiency; construction, installation and protection of cables and other elements of outside plant
Series M	Telecommunication management, including TMN and network maintenance
Series N	Maintenance: international sound programme and television transmission circuits
Series O	Specifications of measuring equipment
Series P	Telephone transmission quality, telephone installations, local line networks
Series Q	Switching and signalling, and associated measurements and tests
Series R	Telegraph transmission
Series S	Telegraph services terminal equipment
Series T	Terminals for telematic services
Series U	Telegraph switching
Series V	Data communication over the telephone network
Series X	Data networks, open system communications and security
Series Y	Global information infrastructure, Internet protocol aspects, next-generation networks, Internet of Things and smart cities
Series Z	Languages and general software aspects for telecommunication systems