

International Telecommunication Union

ITU-T

G.8263/Y.1363

TELECOMMUNICATION
STANDARDIZATION SECTOR
OF ITU

(02/2012)

SERIES G: TRANSMISSION SYSTEMS AND MEDIA,
DIGITAL SYSTEMS AND NETWORKS

Packet over Transport aspects – Quality and availability
targets

SERIES Y: GLOBAL INFORMATION
INFRASTRUCTURE, INTERNET PROTOCOL ASPECTS
AND NEXT GENERATION NETWORKS

Internet protocol aspects – Transport

**Timing characteristics of packet-based
equipment clocks**

Recommendation ITU-T G.8263/Y.1363



ITU-T G-SERIES RECOMMENDATIONS

TRANSMISSION SYSTEMS AND MEDIA, DIGITAL SYSTEMS AND NETWORKS

INTERNATIONAL TELEPHONE CONNECTIONS AND CIRCUITS	G.100–G.199
GENERAL CHARACTERISTICS COMMON TO ALL ANALOGUE CARRIER-TRANSMISSION SYSTEMS	G.200–G.299
INDIVIDUAL CHARACTERISTICS OF INTERNATIONAL CARRIER TELEPHONE SYSTEMS ON METALLIC LINES	G.300–G.399
GENERAL CHARACTERISTICS OF INTERNATIONAL CARRIER TELEPHONE SYSTEMS ON RADIO-RELAY OR SATELLITE LINKS AND INTERCONNECTION WITH METALLIC LINES	G.400–G.449
COORDINATION OF RADIOTELEPHONY AND LINE TELEPHONY	G.450–G.499
TRANSMISSION MEDIA AND OPTICAL SYSTEMS CHARACTERISTICS	G.600–G.699
DIGITAL TERMINAL EQUIPMENTS	G.700–G.799
DIGITAL NETWORKS	G.800–G.899
DIGITAL SECTIONS AND DIGITAL LINE SYSTEM	G.900–G.999
MULTIMEDIA QUALITY OF SERVICE AND PERFORMANCE – GENERIC AND USER-RELATED ASPECTS	G.1000–G.1999
TRANSMISSION MEDIA CHARACTERISTICS	G.6000–G.6999
DATA OVER TRANSPORT – GENERIC ASPECTS	G.7000–G.7999
PACKET OVER TRANSPORT ASPECTS	G.8000–G.8999
Ethernet over Transport aspects	G.8000–G.8099
MPLS over Transport aspects	G.8100–G.8199
Quality and availability targets	G.8200–G.8299
Service Management	G.8600–G.8699
ACCESS NETWORKS	G.9000–G.9999

For further details, please refer to the list of ITU-T Recommendations.

Recommendation ITU-T G.8263/Y.1363

Timing characteristics of packet-based equipment clocks

Summary

Recommendation ITU-T G.8263/Y.1363 outlines requirements for timing devices used in synchronizing network equipment that operates in the interworking function (IWF) and other network elements as defined in Recommendation ITU-T G.8261/Y.1361. This Recommendation defines the requirements for packet-based equipment clocks.

History

Edition	Recommendation	Approval	Study Group
1.0	ITU-T G.8263/Y.1363	2012-02-13	15

Keywords

Clock, jitter, synchronization, wander.

FOREWORD

The International Telecommunication Union (ITU) is the United Nations specialized agency in the field of telecommunications, information and communication technologies (ICTs). The ITU Telecommunication Standardization Sector (ITU-T) is a permanent organ of ITU. ITU-T is responsible for studying technical, operating and tariff questions and issuing Recommendations on them with a view to standardizing telecommunications on a worldwide basis.

The World Telecommunication Standardization Assembly (WTSA), which meets every four years, establishes the topics for study by the ITU-T study groups which, in turn, produce Recommendations on these topics.

The approval of ITU-T Recommendations is covered by the procedure laid down in WTSA Resolution 1.

In some areas of information technology which fall within ITU-T's purview, the necessary standards are prepared on a collaborative basis with ISO and IEC.

NOTE

In this Recommendation, the expression "Administration" is used for conciseness to indicate both a telecommunication administration and a recognized operating agency.

Compliance with this Recommendation is voluntary. However, the Recommendation may contain certain mandatory provisions (to ensure, e.g., interoperability or applicability) and compliance with the Recommendation is achieved when all of these mandatory provisions are met. The words "shall" or some other obligatory language such as "must" and the negative equivalents are used to express requirements. The use of such words does not suggest that compliance with the Recommendation is required of any party.

INTELLECTUAL PROPERTY RIGHTS

ITU draws attention to the possibility that the practice or implementation of this Recommendation may involve the use of a claimed Intellectual Property Right. ITU takes no position concerning the evidence, validity or applicability of claimed Intellectual Property Rights, whether asserted by ITU members or others outside of the Recommendation development process.

As of the date of approval of this Recommendation, ITU had received notice of intellectual property, protected by patents, which may be required to implement this Recommendation. However, implementers are cautioned that this may not represent the latest information and are therefore strongly urged to consult the TSB patent database at <http://www.itu.int/ITU-T/ipr/>.

© ITU 2012

All rights reserved. No part of this publication may be reproduced, by any means whatsoever, without the prior written permission of ITU.

Table of Contents

	Page
1 Scope	1
2 References.....	1
3 Definitions	2
4 Abbreviations and acronyms	2
5 Frequency accuracy	4
5.1 Packet-based equipment clock – slave – frequency	4
6 Noise generation	4
6.1 PEC-S-F.....	5
7 Packet delay variation noise tolerance.....	6
7.1 PEC-S-F.....	6
8 Long-term phase transient response (holdover)	6
8.1 PEC-S-F.....	6
9 Phase response to packet timing interruptions.....	7
10 Interfaces.....	8
Annex A – Packet-based clock functional model	9
Appendix I – Packet delay variation noise tolerance – testing methodology	10
Appendix II – Considerations on packet rates	11
Appendix III – Considerations on PEC-S-F time constant.....	12

Recommendation ITU-T G.8263/Y.1363

Timing characteristics of packet-based equipment clocks

1 Scope

This Recommendation outlines minimum requirements for the timing functions of the packet slave clocks as defined in [ITU-T G.8265]. It supports frequency synchronization distribution when using packet-based methods.

This Recommendation allows for proper network operation when a packet slave clock is timed from a packet master clock as defined in [ITU-T G.8265].

This Recommendation focuses on mobile applications, and in particular on the delivery of frequency synchronization for end applications such as mobile base stations. It supports the architecture defined in [ITU-T G.8265]. Other applications are for further study.

This Recommendation focuses on two different deployment cases for the packet slave clock:

- Packet slave clock embedded in a device co-located with the end application, as shown after the connection C1 in Figure 3 of [ITU-T G.8261.1].
- Packet slave clock embedded within the end application, as shown after the connection C2 in Figure 3 of [ITU-T G.8261.1]. This second case is for further study for the first version of this Recommendation.

Other deployment cases for the packet slave clock are for further study.

This Recommendation focuses on the types of networks corresponding to the HRM-1 and HRM-2 as defined in [ITU-T G.8261.1].

NOTE – For long observation intervals, the PEC-S-F is expected to compensate for temperature variation effects; therefore, the output of the PEC-S-F will converge to the 1 ppb slope.

The HRM-2 type of network is for further study for the first version of this Recommendation. Other types of networks are out of the scope of this Recommendation.

This Recommendation defines the minimum requirements for the packet slave clocks. These requirements apply under the normal environmental conditions specified for the equipment.

This Recommendation includes clock accuracy, packet delay variation (PDV) noise tolerance, holdover performance and noise generation. The start-up conditions (e.g., variable filtering bandwidth at start-up, stabilization period, etc.) are for further study.

2 References

The following ITU-T Recommendations and other references contain provisions which, through reference in this text, constitute provisions of this Recommendation. At the time of publication, the editions indicated were valid. All Recommendations and other references are subject to revision; users of this Recommendation are therefore encouraged to investigate the possibility of applying the most recent edition of the Recommendations and other references listed below. A list of the currently valid ITU-T Recommendations is regularly published. The reference to a document within this Recommendation does not give it, as a stand-alone document, the status of a Recommendation.

[ITU-T G.810] Recommendation ITU-T G.810 (1996), *Definitions and terminology for synchronization networks*.

[ITU-T G.811] Recommendation ITU-T G.811 (1997), *Timing requirements at the outputs of primary reference clocks suitable for plesiochronous operation of international digital links*.

- [ITU-T G.823] Recommendation ITU-T G.823 (2000), *The control of jitter and wander within digital networks which are based on the 2048 kbit/s hierarchy.*
- [ITU-T G.824] Recommendation ITU-T G.824 (2000), *The control of jitter and wander within digital networks which are based on the 1544 kbit/s hierarchy.*
- [ITU-T G.8260] Recommendation ITU-T G.8260 (2012), *Definitions and terminology for synchronization in packet networks.*
- [ITU-T G.8261] Recommendation ITU-T G.8261 (2008), *Timing and synchronization aspects in packet networks.*
- [ITU-T G.8261.1] Recommendation ITU-T G.8261.1 (2012), *Packet delay variation network limits applicable to packet based methods (Frequency synchronization).*
- [ITU-T G.8265] Recommendation ITU-T G.8265 (2010), *Architecture and requirements for packet-based frequency delivery.*
- [ITU-T G.8265.1] Recommendation ITU-T G.8265.1 (2010), *Precision time protocol telecom profile for frequency synchronization.*

3 Definitions

Definitions related to synchronization are contained in [ITU-T G.810] and [ITU-T G.8260].

4 Abbreviations and acronyms

For the purposes of this Recommendation, the following abbreviations and acronyms are used:

ATM	Asynchronous Transfer Mode
BS	Base Station
CBR	Constant Bit Rate
CDMA	Code Division Multiple Access
CE	Customer Equipment
CES	Circuit Emulation Service
DUT	Device Under Test
EEC	synchronous Ethernet Equipment Clock
ESMC	Ethernet Synchronization Messaging Channel
FDD	Frequency Division Duplex
FE	Fast Ethernet
GE	Gigabit Ethernet
GPS	Global Positioning System
GSM	Global System for Mobile communications
HRM	Hypothetical Reference Model
IP DSLAM	IP Digital Subscriber Line Access Multiplexer
IP	Internet Protocol
IWF	Interworking Function
MAC	Medium Access Control

M-CMTS	Modular Cable Modem Termination System
METROE	METRO Ethernet
MPEG	Moving Picture Experts Group
MRTIE	Maximum Relative Time Interval Error
MSAN	Multiservice Access Node
MTIE	Maximum Time Interval Error
NE	Network Element
NTP	Network Time Protocol
OLT	Optical Line Termination
OTN	Optical Transport Network
PDH	Plesiochronous Digital Hierarchy
PDV	Packet Delay Variation
PEC	Packet-based Equipment Clock
PEC-S-F	Packet-based Equipment Clock – Slave – Frequency
PHY	Physical (layer)
PNT	Packet Network Timing
PNT-F	PNT-Function
PRC	Primary Reference Clock
PSC-A	Packet-based Service Clock-Adaptive
PSC-D	Packet-based Service Clock-Differential
PSTN	Public Switched Telephone Network
PTP	Precision Time Protocol
PTS	Packet Timing Signal
PTSF	Packet Timing Signal Fail
QL	Quality Level
SASE	Stand Alone Synchronization Equipment
SDH	Synchronous Digital Hierarchy
SEC	SDH Equipment Clock
SLA	Service Level Agreement
SNTP	Simple Network Time Protocol
SRTS	Synchronous Residual Time Stamp
SSM	Synchronization Status Message
SSU	Synchronization Supply Unit
STM	Synchronous Transfer Mode
TCP	Transmission Control Protocol
TDD	Time Division Duplex
TDEV	Time Deviation

TDM PW	TDM PseudoWire
TDM	Time Division Multiplex
ToD	Time of Day
UI	Unit Interval
UTC	Coordinated Universal Time
WCDMA	Wideband Code Division Multiple Access

5 Frequency accuracy

5.1 Packet-based equipment clock – slave – frequency

Under free running conditions, the output frequency accuracy of the packet-based equipment clock – slave – frequency (PEC-S-F) should not be greater than 4.6 ppm with regard to a reference traceable to an ITU-T G.811 clock.

NOTE – The time interval for this accuracy is for further study. Values of one month and one year have been proposed.

6 Noise generation

The noise generation of a PEC-S represents the amount of phase noise produced at the output of the PEC-S when there is an ideal input reference packet timing signal. Figure 1 illustrates the testing procedure:

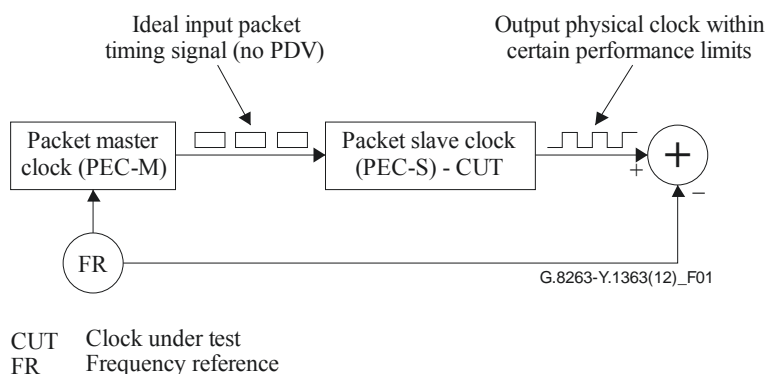

Figure 1 – Noise generation testing procedure

It should be noted that packet-based equipment clocks – slave – frequency according to the architecture defined in [ITU-T G.8265] (see Figure 1 of [ITU-T G.8265]) are not cascaded; therefore it would not be required to specify noise generation produced at the output of the clock when there is an ideal input reference signal. In fact the applicable noise generation requirement is already covered by the specifications provided in clause 7 of this Recommendation. However, this specification is provided in order to enable network operators to measure the noise produced by the PEC-S-F under ideal conditions, separately from the scenarios where packet delay variation (PDV) is applied (PDV noise tolerance testing).

The maximum time interval error (MTIE) is measured through an equivalent 10 Hz, first-order, low-pass measurement filter, at a maximum sampling time of 1/30 seconds.

6.1 PEC-S-F

When the PEC-S-F is in the locked mode of operation, synchronized to a packet delay variation free reference, and its MTIE output is measured using the same reference as the packet master clock which generated the packet timing signal, the MTIE should have the limits described in Table 1, if the temperature is constant (within $\pm 1^\circ\text{K}$).

Table 1 – Wander generation (MTIE) for PEC-S-F with constant temperature

MTIE limit (ns)	Observation interval τ (s)
1000	$0.1 < \tau \leq 1000$
τ	$\tau > 1000$ (Note)
NOTE – The maximum applicable observation interval is for further study.	

The resultant requirement is shown by the solid line in Figure 2.

When temperature effects are included, the allowance for the total MTIE contribution increases by the values in Table 2.

Table 2 – Additional wander generation (MTIE) for PEC-S-F with temperature effects

Additional MTIE allowance (ns)	Observation interval τ (s)
1000	$0.1 < \tau \leq 100$
10τ	$\tau > 100$ (Note)
NOTE – The maximum applicable observation interval is for further study.	

The resultant requirements are shown by the dashed line in Figure 2.

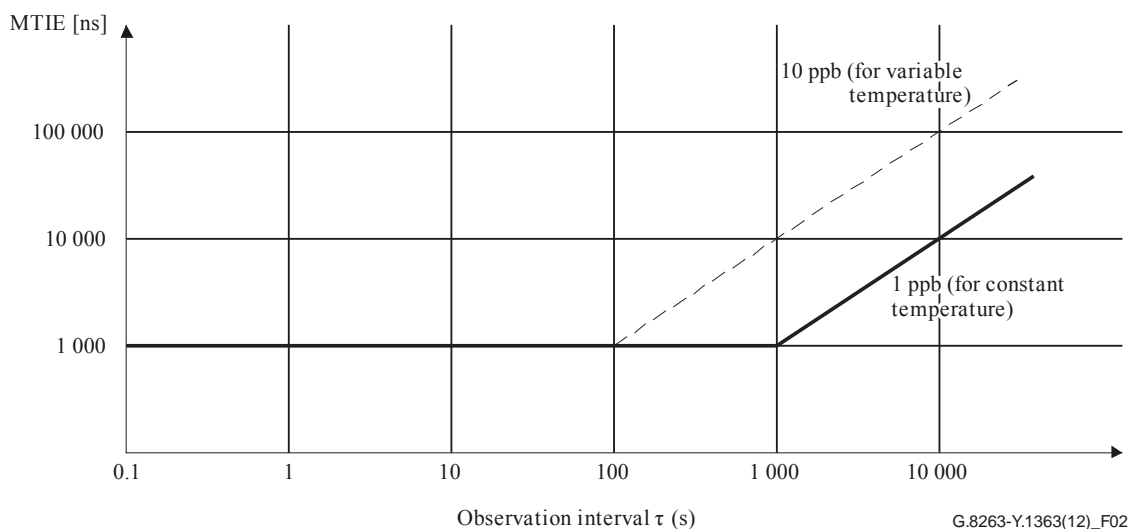

Figure 2 – Wander generation (MTIE) for packet-based equipment clock – slave – frequency (PEC-S-F)

NOTE – For long observation intervals the PEC-S-F is expected to compensate for temperature variation effects; therefore, the output of the PEC-S-F will converge to the 1 ppb slope.

7 Packet delay variation noise tolerance

7.1 PEC-S-F

The packet delay variation (PDV) noise tolerance of the PEC-S-F indicates the minimum packet delay variation noise at the input of the PEC-S-F. It indicates the noise at the packet timing signal (PTS) that the PEC-S-F must tolerate.

The model for a packet slave clock is shown in Figure A.1. The transfer characteristics of PEC-S-F determines its property with regard to the filtering of PDV noise at the packet timing signal and generates a clock frequency traceable to the input timing signal available at the packet master clock.

The PEC-S-F must tolerate the noise at the limits specified in clause 8 of [ITU-T G.8261.1] (PDV network limits at point C). Under these conditions the output clock of the PEC-S-F must:

- not cause the PTSF-unusable signal to be triggered (this is for further study)
- not cause the clock to go into holdover
- maintain the clock within the following prescribed performance limits, depending on the applicable use case:
 - The limits defined for Case 3 in clause 7.2.2 of [ITU-T G.8261.1], as defined in reference point D in Figure 3 of [ITU-T G.8261.1], or
 - The limits defined for Case 2 in clause 7.2.2 of [ITU-T G.8261.1], as defined in reference point D in Figure 3 of [ITU-T G.8261.1]. This case is for further study.

NOTE 1 – The above limits apply to a PEC-S-F external to the end application (point C1 in Figure 3 of [ITU-T G.8261.1]). The limits corresponding to the end application at the point E in Figure 3 of [ITU-T G.8261.1] for the case of a PEC-S-F embedded in the end application (point C2 in Figure 3 of [ITU-T G.8261.1]) are for further study.

NOTE 2 – For the particular packet rate used by an actual PEC-S-F implementation, within the range specified in [ITU-T G.8265.1], the clock must tolerate the PDV generated by the network as specified in [ITU-T G.8261.1]. More specifically, for the HRM-1 of [ITU-T G.8261.1], the PEC-S-F must also meet the output performance specification for its particular packet rate when only 1% of the timing packets sent by the packet master remain in the 150 μ s fixed cluster range, starting at the floor delay in every observation window of 200 s.

NOTE 3 – The way to generate packet timing signal (PDV pattern) experiencing noise at the limits specified in clause 8 of [ITU-T G.8261.1], is for further study. For the purpose of PDV input tolerance testing, the maximum duration of the test period is for further study. Possible testing methodologies for HRM-1 of [ITU-T G.8261.1] is for further study (see Appendix I of this Recommendation).

8 Long-term phase transient response (holdover)

When a PEC-S clock loses all its references, it enters the holdover state. This clause describes the required behaviour of the PEC-S clock during this state.

NOTE – This specification for holdover applies assuming that there is no frequency offset before entering holdover. Other cases are for further study.

8.1 PEC-S-F

For the PEC-S-F deployed as per ITU-T G.8265 architecture, in general, there are no requirements for long-term holdover. In this case, it is expected that when the quality at the output of the PEC-S-F is not sufficiently good (e.g., PRC traceability is lost), the output timing reference should be squelched so as to let the end application enter holdover.

However, in some cases it might not be possible to squelch the output reference timing signal (e.g., reference timing signal carried by 2048 kbit/s traffic signal, as related to some CES applications). In these cases, when available, the SSM carried in 2048 kbit/s signal as per

[ITU-T G.704] could be used to inform the connected equipment that primary reference clock (PRC) traceability is lost. As an alternative, a management alarm could be raised in order to inform connected equipment through the management layer.

If none of these options is possible (e.g., end application not supporting the SSM), then some long-term holdover may be required. In this case, the following holdover specification applies.

The phase error, Δx at the output of the PEC-S-F relative to the input at the moment of loss of reference should, over any period of S seconds, not exceed the following limit:

$$|\Delta x(S)| \leq \{(\mathbf{a}_1 + \mathbf{a}_2)S + 0.5 \mathbf{b} S^2 + \mathbf{c}\}[\text{ns}]$$

The derivative of $\Delta x(S)$, the fractional frequency offset, should, over any period of S seconds, meet the following:

$$|d(\Delta x(S))/dS| \leq \{\mathbf{a}_1 + \mathbf{a}_2 + \mathbf{b}S\}[\text{ns/s}]$$

The second derivative of $\Delta x(S)$, the fractional frequency drift, should, over any period of S seconds, meet the following:

$$|d^2(\Delta x(S))/dS^2| \leq \mathbf{d} [\text{ns/s}^2]$$

In applying the above requirements for the derivative of $\Delta x(S)$ and the second derivative of $\Delta x(S)$, the period S must begin after any transient associated with entry into holdover is over.

NOTE 1 – \mathbf{a}_1 represents an initial frequency offset under constant temperature conditions (± 1 K).

NOTE 2 – \mathbf{a}_2 accounts for temperature variations after the clock went into holdover. If there are no temperature variations, the term $\mathbf{a}_2 S$ should not contribute to the phase error.

NOTE 3 – \mathbf{b} represents the average frequency drift caused by aging. This value is derived from typical aging characteristics after 60 days of continuous operation. It is not intended to measure this value on a per day basis, as the temperature effect will dominate.

NOTE 4 – The phase offset \mathbf{c} takes care of any additional phase shift that may arise during the transition at the entry of the holdover state.

NOTE 5 – \mathbf{d} represents the maximum temporary frequency drift rate at constant temperature allowed during holdover. However, it is not required that \mathbf{d} and \mathbf{b} be equal.

The permissible phase error specifications are shown in Table 3.

Table 3 – Transient response specifications during hold-over

\mathbf{a}_1 (ns/s)	1.0
\mathbf{a}_2 (ns/s)	10
\mathbf{b} (ns/s ²)	1.16×10^{-5}
\mathbf{c} (ns)	150
\mathbf{d} (ns/s ²)	1.16×10^{-5}

9 Phase response to packet timing interruptions

Phase response to packet timing interruptions is for further study.

10 Interfaces

The requirements in this Recommendation are related to reference points internal to the network elements (NEs) in which the clock is embedded and are, therefore, not necessarily available for measurement or analysis by the user. Therefore, the performance of the PEC-S-F is not defined at these internal reference points, but rather at the external interfaces of the equipment.

The synchronization input interface for equipment in which the PEC-S-F may be contained is Ethernet, where the timing is carried at the packet layer.

The synchronization output interfaces for equipment in which the PEC-S-F may be contained are:

- 1544-kbit/s interfaces according to [ITU-T G.703];
- 2048-kHz external interfaces according to [ITU-T G.703];
- 2048-kbit/s interfaces according to [ITU-T G.703];
- synchronous Ethernet interfaces.

NOTE 1 – The performance of this interface may not meet [ITU-T G.8262].

Not all of the above interfaces need be implemented on all equipment. These interfaces should comply with the requirements as defined in this Recommendation. The use of other interfaces is for further study.

NOTE 2 – For synchronous Ethernet interfaces, refer to Appendix III of [ITU-T G.8262].

Annex A

Packet-based clock functional model

(This annex forms an integral part of this Recommendation.)

This annex describes a functional model.

Figure A.1 shows a functional model of a packet-based equipment clock – slave – frequency (PEC-S-F). The packet timing signal is processed by a packet selection algorithm to select the packets that are going to be used to recover the clock. The time information carried in the selected packets are used as an input to the time scale comparator to compare the master and local time scales. The time difference between the arrival and departure times can be used as an error signal to control the rate of the local oscillator driving the local time scale, such that the local time scale advances at the same rate as the master time scale. The local reference may come from a stable oscillator, or the "Output clock". Figure A.1 represents a functional model and it is not intended to specify any specific implementation. Any specific detail on implementation is outside the scope of this Recommendation.

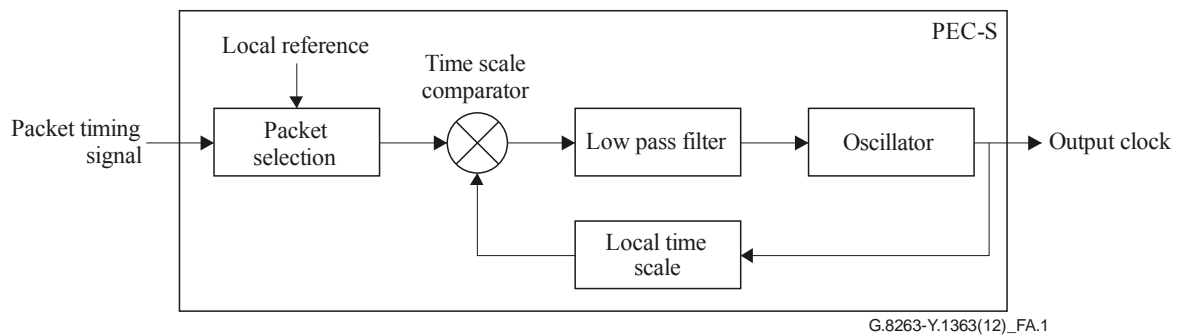

Figure A.1 – Functional model of a packet-based equipment clock – slave – frequency (PEC-S-F)

Appendix I

Packet delay variation noise tolerance – testing methodology

(This appendix does not form an integral part of this Recommendation.)

The test methodology for the HRM-1 of [ITU-T G.8261.1] is for further study.

Appendix II

Considerations on packet rates

(This appendix does not form an integral part of this Recommendation.)

This Recommendation does not require any specific packet rate for the packet based clock.

The applicable reference in the case of packet-based equipment clock – slave – frequency (PEC-F-S) would be [ITU-T G.8265.1] where the packet rate has been defined to be in the range of one packet every 16 seconds to 128 packets per second. It is not expected that a specific PEC-S-F implementation would meet the performance requirements over the whole of this range, and the actual value to be used depends on the stability of the oscillator, the traffic load and type of the network, and on the target application.

Experience has shown that for a PEC-S-F as specified in this Recommendation, packet rates higher than 1 packet/second are typically used to meet the requirements specified in case 3 of clause 7.2.2 of [ITU-T G.8261.1], when operated over a network similar to HRM-1 of [ITU-T G.8261.1].

The choice of a packet rate may significantly impact the requirements on the oscillator stability.

Note that the packet rate of interest for this Recommendation is during the steady state conditions (the start-up is out of scope).

Appendix III

Considerations on PEC-S-F time constant

(This appendix does not form an integral part of this Recommendation.)

This Recommendation does not require any specific time constant for the PEC-S-F packet-based clock. This Recommendation only requires that the relevant output performance objectives specified in [ITU-T G.8261.1] (e.g., Figure 4 of [ITU-T G.8261.1]) are respected when the input PDV noise applied to the PEC-S-F is within the PDV network limits specified in [ITU-T G.8261.1] (e.g., clause 8 of [ITU-T G.8261.1]).

NOTE 1 – The time constant, τ_c , is related to the 3 dB bandwidth of the PLL, f_{3db} , by the following relationship: $\tau_c = 1/(2\pi f_{3db})$.

Studies have been performed considering a PEC-S-F following the packet-based slave clock functional model defined in Annex A of [ITU-T G.8263], based upon a second order phase-locked loop, in order to determine appropriate time constant values. In these studies, PDV data in line with the network limit defined in [ITU-T G.8261.1] for the HRM-1 have been considered.

These studies have shown that a time constant considerably higher than traditional clocks based on the physical layer (e.g., SEC/EEC), in the order of a thousand seconds or more, may be necessary to meet the requirements of Figure 4 of [ITU-T G.8261.1].

NOTE 2 – The time constant of a given PEC-S-F implementation also depends on the budget allocated to the oscillator noise, which is especially related to the variable temperature effects. Oscillator noise, caused by aging and environmental effects, can indeed limit the practical performance of a PEC-S-F and should therefore be taken into consideration.

The PEC-S-F acts as a low-pass filter for input noise whilst acting as a high-pass filter for oscillator noise. For a given oscillator performance, the selection of the loop time constant represents a compromise between the practical attenuation of input noise and the admittance of oscillator noise.

If the target performance of the PEC-S-F corresponds to the requirements of Figure 4 of [ITU-T G.8261.1], the long-term fractional frequency offset of the output (i.e., as measured at observation intervals greater than 1125 seconds) should not exceed 16 ppb under applicable input noise conditions and under the applicable environmental conditions and throughout the lifetime of the oscillator.

To separate the influence of the oscillator from the influence of the input noise, two particular operating conditions could be considered: firstly, for a candidate time constant in the PEC-S-F, the influence of the oscillator could be found using minimum levels of input noise; in such a case, a target objective of x ppb long-term fractional frequency offset could be used to set a minimum performance for the oscillator. The time constant of the PEC-S-F can then be chosen so that the long-term fractional frequency offset of the output remains below (16-x) ppb under applicable input noise conditions within the PDV network limits when using an ideal oscillator.

Note that the time constant of interest for this Recommendation, and discussed in this appendix, is during the steady state conditions (the start-up is out of scope).

ITU-T Y-SERIES RECOMMENDATIONS
**GLOBAL INFORMATION INFRASTRUCTURE, INTERNET PROTOCOL ASPECTS AND NEXT-
GENERATION NETWORKS**

GLOBAL INFORMATION INFRASTRUCTURE

General	Y.100–Y.199
Services, applications and middleware	Y.200–Y.299
Network aspects	Y.300–Y.399
Interfaces and protocols	Y.400–Y.499
Numbering, addressing and naming	Y.500–Y.599
Operation, administration and maintenance	Y.600–Y.699
Security	Y.700–Y.799
Performances	Y.800–Y.899

INTERNET PROTOCOL ASPECTS

General	Y.1000–Y.1099
Services and applications	Y.1100–Y.1199
Architecture, access, network capabilities and resource management	Y.1200–Y.1299

Transport **Y.1300–Y.1399**

Interworking	Y.1400–Y.1499
Quality of service and network performance	Y.1500–Y.1599
Signalling	Y.1600–Y.1699
Operation, administration and maintenance	Y.1700–Y.1799
Charging	Y.1800–Y.1899
IPTV over NGN	Y.1900–Y.1999

NEXT GENERATION NETWORKS

Frameworks and functional architecture models	Y.2000–Y.2099
Quality of Service and performance	Y.2100–Y.2199
Service aspects: Service capabilities and service architecture	Y.2200–Y.2249
Service aspects: Interoperability of services and networks in NGN	Y.2250–Y.2299
Numbering, naming and addressing	Y.2300–Y.2399
Network management	Y.2400–Y.2499
Network control architectures and protocols	Y.2500–Y.2599
Smart ubiquitous networks	Y.2600–Y.2699
Security	Y.2700–Y.2799
Generalized mobility	Y.2800–Y.2899
Carrier grade open environment	Y.2900–Y.2999
Future networks	Y.3000–Y.3099

For further details, please refer to the list of ITU-T Recommendations.

SERIES OF ITU-T RECOMMENDATIONS

Series A	Organization of the work of ITU-T
Series D	General tariff principles
Series E	Overall network operation, telephone service, service operation and human factors
Series F	Non-telephone telecommunication services
Series G	Transmission systems and media, digital systems and networks
Series H	Audiovisual and multimedia systems
Series I	Integrated services digital network
Series J	Cable networks and transmission of television, sound programme and other multimedia signals
Series K	Protection against interference
Series L	Construction, installation and protection of cables and other elements of outside plant
Series M	Telecommunication management, including TMN and network maintenance
Series N	Maintenance: international sound programme and television transmission circuits
Series O	Specifications of measuring equipment
Series P	Terminals and subjective and objective assessment methods
Series Q	Switching and signalling
Series R	Telegraph transmission
Series S	Telegraph services terminal equipment
Series T	Terminals for telematic services
Series U	Telegraph switching
Series V	Data communication over the telephone network
Series X	Data networks, open system communications and security
Series Y	Global information infrastructure, Internet protocol aspects and next-generation networks
Series Z	Languages and general software aspects for telecommunication systems