

Recommendation

ITU-T G.8271.2/Y.1366.2 (2021) Amd. 1 (11/2022)

SERIES G: Transmission systems and media, digital systems and networks

Packet over Transport aspects – Synchronization, quality and availability targets

SERIES Y: Global information infrastructure, Internet protocol aspects, next-generation networks, Internet of Things and smart cities

Internet protocol aspects – Transport

Network limits for time synchronization in packet networks with partial timing support from the network

Amendment 1



ITU-T G-SERIES RECOMMENDATIONS
TRANSMISSION SYSTEMS AND MEDIA, DIGITAL SYSTEMS AND NETWORKS

INTERNATIONAL TELEPHONE CONNECTIONS AND CIRCUITS	G.100–G.199
GENERAL CHARACTERISTICS COMMON TO ALL ANALOGUE CARRIER-TRANSMISSION SYSTEMS	G.200–G.299
INDIVIDUAL CHARACTERISTICS OF INTERNATIONAL CARRIER TELEPHONE SYSTEMS ON METALLIC LINES	G.300–G.399
GENERAL CHARACTERISTICS OF INTERNATIONAL CARRIER TELEPHONE SYSTEMS ON RADIO-RELAY OR SATELLITE LINKS AND INTERCONNECTION WITH METALLIC LINES	G.400–G.449
COORDINATION OF RADIOTELEPHONY AND LINE TELEPHONY	G.450–G.499
TRANSMISSION MEDIA AND OPTICAL SYSTEMS CHARACTERISTICS	G.600–G.699
DIGITAL TERMINAL EQUIPMENTS	G.700–G.799
DIGITAL NETWORKS	G.800–G.899
DIGITAL SECTIONS AND DIGITAL LINE SYSTEM	G.900–G.999
MULTIMEDIA QUALITY OF SERVICE AND PERFORMANCE – GENERIC AND USER-RELATED ASPECTS	G.1000–G.1999
TRANSMISSION MEDIA CHARACTERISTICS	G.6000–G.6999
DATA OVER TRANSPORT – GENERIC ASPECTS	G.7000–G.7999
PACKET OVER TRANSPORT ASPECTS	G.8000–G.8999
Ethernet over Transport aspects	G.8000–G.8099
MPLS over Transport aspects	G.8100–G.8199
Synchronization, quality and availability targets	G.8200–G.8299
Mobile network transport aspects	G.8300–G.8399
Service Management	G.8600–G.8699
ACCESS NETWORKS	G.9000–G.9999

For further details, please refer to the list of ITU-T Recommendations.

Recommendation ITU-T G.8271.2/Y.1366.2

Network limits for time synchronization in packet networks with partial timing support from the network

Amendment 1

Summary

Recommendation ITU-T G.8271.2/Y.1366.2 specifies the maximum network limits of phase and time error that shall not be exceeded. It specifies the minimum equipment tolerance to phase and time error that shall be provided at the boundary of these packet networks at phase and time synchronization interfaces. It also outlines the minimum requirements for the synchronization function of network elements.

Recommendation ITU-T G.8271.2/Y.1366.2 addresses the case of time and phase distribution across a network with the packet-based method with partial timing support to the protocol level from the network.

The changes in this amendment include the following:

- Addition of notes regarding the use of T-BC-A and T-BC-P in clauses 7.4.1 and 7.4.2 respectively.

History

Edition	Recommendation	Approval	Study Group	Unique ID*
1.0	ITU-T G.8271.2/Y.1366.2	2017-08-13	15	11.1002/1000/13324
1.1	ITU-T G.8271.2/Y.1366.2 (2017) Amd. 1	2018-03-16	15	11.1002/1000/13551
1.2	ITU-T G.8271.2/Y.1366.2 (2017) Amd. 2	2018-11-29	15	11.1002/1000/13768
2.0	ITU-T G.8271.2/Y.1366.2	2021-05-29	15	11.1002/1000/14638
2.1	ITU-T G.8271.2/Y.1366.2 (2021) Amd. 1	2022-11-13	15	11.1002/1000/15151

Keywords

Network limits, partial timing support, phase, precision time protocol, synchronization, time.

* To access the Recommendation, type the URL <http://handle.itu.int/> in the address field of your web browser, followed by the Recommendation's unique ID. For example, <http://handle.itu.int/11.1002/1000/11830-en>.

FOREWORD

The International Telecommunication Union (ITU) is the United Nations specialized agency in the field of telecommunications, information and communication technologies (ICTs). The ITU Telecommunication Standardization Sector (ITU-T) is a permanent organ of ITU. ITU-T is responsible for studying technical, operating and tariff questions and issuing Recommendations on them with a view to standardizing telecommunications on a worldwide basis.

The World Telecommunication Standardization Assembly (WTSA), which meets every four years, establishes the topics for study by the ITU-T study groups which, in turn, produce Recommendations on these topics.

The approval of ITU-T Recommendations is covered by the procedure laid down in WTSA Resolution 1.

In some areas of information technology which fall within ITU-T's purview, the necessary standards are prepared on a collaborative basis with ISO and IEC.

NOTE

In this Recommendation, the expression "Administration" is used for conciseness to indicate both a telecommunication administration and a recognized operating agency.

Compliance with this Recommendation is voluntary. However, the Recommendation may contain certain mandatory provisions (to ensure, e.g., interoperability or applicability) and compliance with the Recommendation is achieved when all of these mandatory provisions are met. The words "shall" or some other obligatory language such as "must" and the negative equivalents are used to express requirements. The use of such words does not suggest that compliance with the Recommendation is required of any party.

INTELLECTUAL PROPERTY RIGHTS

ITU draws attention to the possibility that the practice or implementation of this Recommendation may involve the use of a claimed Intellectual Property Right. ITU takes no position concerning the evidence, validity or applicability of claimed Intellectual Property Rights, whether asserted by ITU members or others outside of the Recommendation development process.

As of the date of approval of this Recommendation, ITU had not received notice of intellectual property, protected by patents/software copyrights, which may be required to implement this Recommendation. However, implementers are cautioned that this may not represent the latest information and are therefore strongly urged to consult the appropriate ITU-T databases available via the ITU-T website at <http://www.itu.int/ITU-T/ipr/>.

© ITU 2023

All rights reserved. No part of this publication may be reproduced, by any means whatsoever, without the prior written permission of ITU.

Table of Contents

	Page
1 Scope	1
2 References.....	2
3 Definitions	3
4 Abbreviations and acronyms	3
5 Conventions	4
6 Network reference model	4
7 Packet network limits	4
7.1 Network limits at reference points A and L	5
7.2 Network limit at reference point B	5
7.3 Network limits at reference point C	5
7.4 Network limit at reference point D.....	7
Appendix I – Deployment scenarios for partial timing support networks.....	9
I.1 APTS and PTS network use cases.....	9
I.2 Full timing support network followed by an APTS network or PTS network.....	10
I.3 PTS network followed by an FTS network	11
I.4 APTS network followed by a PTS network.....	11
I.5 APTS network followed by an FTS network	11
I.6 Use of PTS network to bridge between two FTS networks	12
Appendix II – Considerations for handling precision time protocol traffic in networks with partial timing support.....	13
II.1 Network aspects.....	13
II.2 Time error performance aspects	14
Appendix III – The use of frequency to maintain precise time	15
Appendix IV – Noise accumulation model in partially aware networks	17
Bibliography.....	18

Recommendation ITU-T G.8271.2/Y.1366.2

Network limits for time synchronization in packet networks with partial timing support from the network

Amendment 1

Editorial note: This is a complete-text publication. Modifications introduced by this amendment are shown in revision marks relative to Recommendation ITU-T G.8271.2/Y.1366.2 (2021).

1 Scope

This Recommendation specifies the maximum network limits of phase and time error that shall not be exceeded. It specifies the minimum equipment tolerance to phase and time error that shall be provided at the boundary of these packet networks at phase and time synchronization interfaces. It also outlines the minimum requirements for the synchronization function of network elements.

This Recommendation addresses the distribution of time and phase across a network, using the packet-based method with partial timing support (PTS) to the protocol level from the network. In particular, it applies to the assisted partial timing support (APTS) and PTS architectures described in [ITU-T G.8275] and the precision time protocol (PTP) profile defined in [ITU-T G.8275.2].

This Recommendation addresses the following cases.

1) APTS.

In the APTS configuration, PTP is used as a backup timing source to a local time reference (e.g., primary reference time clock (PRTC) based on the global navigation satellite system (GNSS)) for durations up to 72 h. It is not intended to use PTP as the primary timing source.

Network requirements take into consideration the dynamic time error (dTE) generated by the network.

2) PTS from the network.

In the PTS configuration, PTP is used as the primary source of time to the end application. In this mode, a local time reference (e.g., GNSS) is not available.

Network requirements take into consideration the combination of both the constant time error (cTE) and dTE components generated by the network.

A network that is based on the architecture defined in [ITU-T G.8265], and is designed to meet the network limits for frequency defined in [ITU-T G.8261.1], is not designed for the delivery of accurate time or phase, which requires much lower levels of packet delay variation (PDV) and asymmetry. The network limits specified in this Recommendation are for small, well-controlled networks (e.g., in-building or last-mile network segments), which can guarantee that the stringent PDV and asymmetry network limits are met. Further guidance can be found in Appendix II.

The main focus of this Recommendation is to meet the requirements of Class 4 in [ITU-T G.8271], Table 1, i.e., a maximum absolute time error of 1.5 μ s. Other classes with less stringent requirements are for further study.

The necessary clock specifications are for further study.

The packet networks that are in the scope of this Recommendation are currently limited to the following types:

- Ethernet: [IEEE 802.3] and [IEEE 802.1Q]
- Multiprotocol label switching (MPLS): [IETF RFC 3031] and [ITU-T G.8110]

– Internet protocol (IP): [IETF RFC 791] and [IETF RFC 2460]

The use of other network types are for further study.

The physical layer that is relevant to this specification is the Ethernet media type as defined in [IEEE 802.3].

2 References

The following ITU-T Recommendations and other references contain provisions which, through reference in this text, constitute provisions of this Recommendation. At the time of publication, the editions indicated were valid. All Recommendations and other references are subject to revision; users of this Recommendation are therefore encouraged to investigate the possibility of applying the most recent edition of the Recommendations and other references listed below. A list of the currently valid ITU-T Recommendations is regularly published. The reference to a document within this Recommendation does not give it, as a standalone document, the status of a Recommendation.

- [ITU-T G.810] Recommendation ITU-T G.810 (1996), *Definitions and Terminology for Synchronization Networks*.
- [ITU-T G.8110] Recommendation ITU-T G.8110/Y.1370 (2005), *MPLS Layer Network Architecture*.
- [ITU-T G.8260] Recommendation ITU-T G.8260 (2022~~9~~), *Definitions and Terminology for Synchronization in Packet Networks*.
- [ITU-T G.8261.1] Recommendation ITU-T G.8261.1/Y.1361.1 (2012), *Packet Delay Variation Network Limits Applicable to Packet-based Methods (Frequency Synchronization)*.
- [ITU-T G.8265] Recommendation ITU-T G.8265/Y.1365 (2010), *Architecture and Requirements for Packet-based Frequency Delivery*.
- [ITU-T G.8271] Recommendation ITU-T G.8271/Y.1366 (2020), *Time and Phase Synchronization Aspects of Telecommunication Networks*.
- [ITU-T G.8271.1] Recommendation ITU-T G.8271.1/Y.1366.1 (2022~~9~~), *Network Limits for Time Synchronization in Packet Networks with full timing support from the network*.
- [ITU-T G.8272] Recommendation ITU-T G.8272/Y.1367 (2018), *Timing Characteristics of Primary Reference Time Clocks*.
- [ITU-T G.8273.4] Recommendation ITU-T G.8273.4/Y.1368.4 (2020), *Timing Characteristics of Telecom Boundary Clocks and Telecom Time Slave Clocks for Use with Partial Timing Support from the Network*.
- [ITU-T G.8275] Recommendation ITU-T G.8275/Y.1369 (2020), *Architecture and Requirements for Packet-based Time and Phase Distribution*.
- [ITU-T G.8275.1] Recommendation ITU-T G.8275.1/Y.1369.1 (2022~~9~~), *Precision Time Protocol Telecom Profile for Phase/Time Synchronization with Full Timing Support from the Network*.
- [ITU-T G.8275.2] Recommendation ITU-T G.8275.2/Y.1369.2 (2022~~9~~), *Precision Time Protocol Telecom Profile for Time/Phase Synchronization with Partial Timing Support from the Network*.
- [IEEE 802.1Q] IEEE 802.1Q-2018, *IEEE Standard for Local and Metropolitan Area Network--Bridges and Bridged Networks*.
- [IEEE 802.3] IEEE 802.3-2022~~4~~8, *IEEE Standard for Ethernet*.

- [IEEE 1588-2008] IEEE 1588-2008, *IEEE Standard for a Precision Clock Synchronization Protocol for Networked Measurement and Control Systems*.
- [IEEE 1588-2019] IEEE 1588-2019, *IEEE Standard for a Precision Clock Synchronization Protocol for Networked Measurement and Control Systems*.
- [IETF RFC 791] IETF RFC 791 (1981), *Internet Protocol (IP)*.
- [IETF RFC 2460] IETF RFC 2460 (1998), *Internet Protocol, Version 6 (IPv6) Specification*.
- [IETF RFC 3031] IETF RFC 3031 (2001), *Multiprotocol Label Switching Architecture*.

3 Definitions

The terms and definitions used in this Recommendation are contained in [ITU-T G.810] and [ITU-T G.8260]

4 Abbreviations and acronyms

This Recommendation uses the following abbreviations and acronyms:

APTS	Assisted Partial Timing Support
BCMA	Best Master Clock Algorithm
<u>CPRI</u>	<u>Common Public Radio Interface</u>
cTE	constant Time Error
dTE	dynamic Time Error
FTS	Full Timing Support
GNSS	Global Navigation Satellite System
IP	Internet Protocol
IWF F-P	Interworking Function from FTS to PTS
IWF P-F	Interworking Function from PTS to FTS
IWF	Interworking Function
MPLS	Multiprotocol Label Switching
PDV	Packet Delay Variation
PRS	Primary Reference Source
PRTC	Primary Reference Time Clock
PTP	Precision Time Protocol
PTS	Partial Timing Support
RAN	Radio Access Network
T-BC	Telecom Boundary Clock
T-BC-A	Telecom Boundary Clock – Partial Support
T-BC-P	Telecom Boundary Clock – Partial support
T-GM	Telecom Grandmaster
TLV	Type Length Variable
T-TSC	Telecom Time Slave Clock

- T-TSC-A Telecom Time Slave Clock – Assisted
- T-TSC-P Telecom Time Slave Clock – Partial support

5 Conventions

Within this Recommendation, the following conventions are used: the term PTP refers to the protocol defined in [IEEE 1588-2008] and [IEEE 1588-2019].

The term PRTC refers to the PRTC-A specification defined in [ITU-T G.8272]. A PRTC-B could be substituted as an alternative.

The term telecom boundary clock – assisted (T-BC-A) (e.g., by GNSS) refers to a device consisting of a boundary clock as defined in [IEEE 1588-2008] and [IEEE 1588-2019], assisted by a local time reference clock device, and with additional performance characteristics as specified in [ITU-T G.8273.4].

The term telecom boundary clock – partial support (T-BC-P) refers to a device consisting of a boundary clock as defined in [IEEE 1588-2008] and [IEEE 1588-2019], with only PTS at the protocol level from the network, and with additional performance characteristics specified in [ITU-T G.8273.4].

The term telecom time slave clock – assisted (T-TSC-A) (e.g., by GNSS) refers to a device consisting of a PTP slave only ordinary clock as defined in [IEEE 1588-2008] and [IEEE 1588-2019], assisted by a local time reference clock device, and with additional performance characteristics as specified in [ITU-T G.8273.4].

The term telecom time slave clock – partial support (T-TSC-P) refers to a device consisting of a PTP slave only ordinary clock as defined in [IEEE 1588-2008] and [IEEE 1588-2019], with only PTS at the protocol level from the network, and with additional performance characteristics as specified in [ITU-T G.8273.4].

The terms "dTE" and "time noise" are used interchangeably throughout this Recommendation to indicate jitter and wander components of the timing signal.

6 Network reference model

The general network reference model is described in [ITU-T G.8271].

7 Packet network limits

This clause defines the network limits that apply to the packet network, i.e., reference points A, B and C and D in Figures 1 and 2.

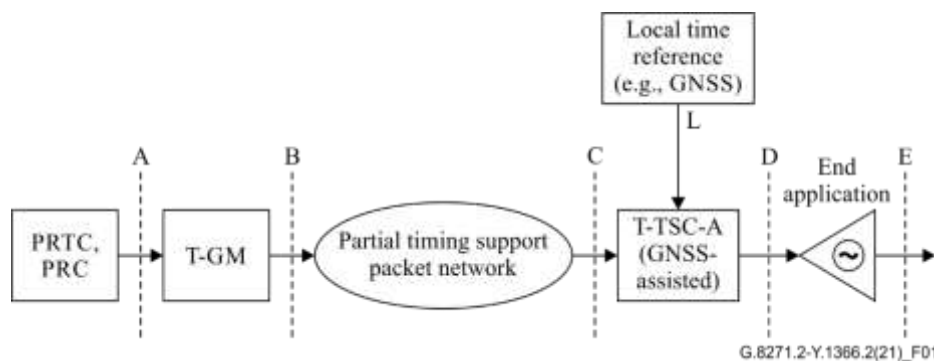

Figure 1 – Reference model for network limits for APTS

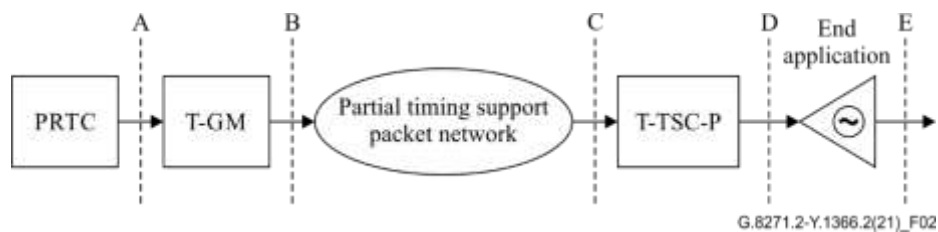

Figure 2 – Reference model for network limits for PTS

The two examples in Figures 1 and 2 are simplified. They represent use cases 1a and 1b in Appendix I. It is highlighted in Appendix I that in some deployment cases, the part of the network located between points C and D may contribute significantly to the total time error budget. In these cases, the network limits apply to point D.

NOTE – The network limit applicable at reference point E is defined by the specific application per Table 1 of [ITU-T G.8271]. The applications corresponding to Class 4 (1.5 microseconds), according to Table 1 of [ITU-T G.8271], are currently considered in this Recommendation.

7.1 Network limits at reference points A and L

The network limits applicable at reference points A and L, i.e., at the output of the PRTC or the local time reference, are defined in [ITU-T G.8272]. In particular, according to [ITU-T G.8272] the maximum absolute time error (TE) is:

$$\max|TE| \leq 100 \text{ ns}$$

NOTE 1 – This limit is applicable under normal, locked operating conditions. The limit under failure conditions at the PRTC is for further study.

NOTE 2 – The network limit at point L may not be applicable in all cases. For example, if a GNSS receiver is embedded within the T-BC-A/T-TSC-A, this interface may not be accessible.

NOTE 3 – The interface at reference point L can be either 1PPS or PTP.

NOTE 4 – In the case that the interface at reference point L is PTP, the PTP profile and domain used at the interface may be:

- the same as for the network between reference points B and C, in which case the normal BCMA (best master clock algorithm) for the profile applies, with higher priority assigned to the local time reference,
- or different, in which case the PTP domains operate independently, and the time source selection is performed at a higher layer than PTP. The local time reference is configured as the primary reference; details of the selection criteria are for further study.

The dTE network limits applicable at the reference points A and L are specified in clause 6.1 of [ITU-T G.8272].

7.2 Network limit at reference point B

In the case of a telecom grandmaster (T-GM) integrated in the PRTC, the network limit applicable at reference point B is the same as the limit applicable at reference point A, measured as described in [ITU-T G.8272].

In the case of a T-GM external to the PRTC, the network limit applicable at reference point B is for further study.

7.3 Network limits at reference point C

The limits for both APTS and PTS below use the metric `pktSelected2wayTE` as described in clause I.4.4.1 of [ITU-T G.8260]. The specific method of calculation is the "percentile average packet selection method" as described in clause I.3.2.2 of [ITU-T G.8260]. The percentile value is defined

in the limit definitions below as "selection percentage". The window size is defined in the limit definitions below as "selection window".

NOTE 1 – Transient events such as packet loss and re-routes may not be indicated by the pktSelected2wayTE metric when the transient events are of short duration compared with the length of the selection window used to compute the metric.

NOTE 2 – The network may be determined to be non-compliant with the network limit requirements when exceptional transient events occur during the selection window (e.g., exceptional transient events that give rise to packet timing signal fail). The exact criteria to define such exceptional transient events is for further study. For details on the measurement methodology in relation to exceptional events, refer to clause I.5.3 of [ITU-T G.8260] "Exceptional events and impact on packet network limit".

7.3.1 Packet network limits for APTS

The limits given in this clause represent the maximum permissible levels of phase/time error and noise at interfaces within a packet network in charge of distributing phase/time synchronization per the applications corresponding to the Class 4 listed in Table 1 of [ITU-T G.8271].

The limits applicable to other classes at the reference point C are for further study.

Two types of network limit are defined. Type I places less stringent requirements on the dTE generated by the network, but requires a correspondingly higher performance from the clock, while type II places more stringent requirements on the dTE generated by the network with a lower performance clock.

The limits given below shall be met for all operating conditions (except during PTP rearrangements), regardless of the amount of equipment preceding the interface. In general, these network limits are compatible with the minimum tolerance to time error and noise that all equipment input ports are required to provide.

The network limit is defined in terms of the peak-to-peak value of pktSelected2wayTE (see Appendix I of [ITU-T G.8260]).

Considering the peak-to-peak value of pktSelected2wayTE as the limit makes sure that whatever the instantaneous value of pktSelected2wayTE when the GNSS source is lost, the absolute TE will remain within expected limits (either positive or negative) while PTP is the selected fall-back source.

Any transient associated with switching from the local time reference to PTP and back is for further study.

NOTE – See Appendix III for considerations on maintaining time with frequency.

7.3.1.1 Type I network limit

The network limit value and the metric processing parameters that apply for a type I network are as follows:

- Peak-to-peak pktSelected2wayTE < 1100 ns
- Selection window = 200 s
- Selection percentage = 0.25%
- Selection method: percentile average packet selection (see clause I.3.2.2 of [ITU-T G.8260])
- Window step size: ≤ 20 s

The network limit calculation method implies that the Sync and Delay_req packet rate must be at least 2 packets/s, in order to receive a valid packet in every selection window. However, the network limit might only be met by using a packet rate higher than 2 packets/s. For proper operation, the T-TSC-A should use a packet rate that is at least as high as the packet rate required for the network limit to be satisfied. It is not expected that any T-TSC-A will meet the relevant target performance requirements at lower packet rates. The appropriate packet rate used by the clocks in the network depends on the clock characteristics and on the target performance requirements.

7.3.1.2 Type II network limit

The network limit value and the metric processing parameters that apply for a type II network are for further study.

7.3.2 Packet network limits for PTS

The limits given in this clause represent the maximum permissible levels of phase/time error and noise, at interfaces within a packet network in charge of distributing phase/time synchronization per the applications corresponding to the Class 4 listing in Table 1 of [ITU-T G.8271].

The limits applicable to other classes at reference point C are for further study.

Two types of network limit are defined. Type I places less stringent requirements on the dTE generated by the network, but requires a correspondingly higher performance from the clock, while type II places more stringent requirements on the dTE generated by the network with a lower performance clock.

The limits given in clauses 7.3.2.1 and 7.3.2.2 shall be met for all operating conditions (except during PTP rearrangements), regardless of the amount of equipment preceding the interface. In general, these network limits are compatible with the minimum tolerance to time error and noise that all equipment input ports are required to provide.

The network limit is defined in terms of the maximum absolute value of pktSelected2wayTE ($\max|\text{pktSelected2wayTE}|$) (see Appendix I of [ITU-T G.8260]).

7.3.2.1 Type I network limit

The network limit value and the metric processing parameters that apply for a type I network are as follows:

- $\max|\text{pktSelected2wayTE}| < 1\ 100\ \text{ns}$
- Selection window = 200 s
- Selection percentage = 0.25%
- Selection method: percentile average packet selection (see clause I.3.2.2 of [ITU-T G.8260])
- Window step size: $\leq 20\ \text{s}$

7.3.2.2 Type II network limit

The network limit value and the metric processing parameters that apply for a type II network are for further study.

7.4 Network limit at reference point D

7.4.1 Network limits for APTS

The network limit applicable at point D is dependent on the end application limit at reference point E. For the case where the end application limit is 1500 ns, when the T-TSC-A is not locked to the local time reference, the maximum absolute time error at reference point D is:

$$\max|\text{TE}_L| \leq 1350\ \text{ns}$$

This requirement is only applicable in the case of a T-TSC-A external to the end application.

When the T-TSC-A is locked to the local time reference, the requirement at reference point D is given by the combination of the local time reference error, and the T-TSC-A noise generation when locked to the local time reference. The value for this requirement is for further study.

A first-order low-pass measurement filter with a bandwidth of 0.1 Hz is applied to the TE samples measured at the 1PPS timing interface prior to evaluating the $\max|\text{TE}|$.

NOTE – In the case that a T-BC-A is located at the end of the clock chain, where the T-TSC-A is usually located, then this network limit would also be met at the 1PPS output(s) of the T-BC-A. The T-BC-A would

additionally have PTP outputs that meet the same output performance as the 1PPS, but these PTP outputs are not part of the reference models at point D of Figure 1.

7.4.2 Network limits for PTS

The network limit applicable at point D is dependent on the end application limit at reference point E. For a case where the end application limit is 1500 ns, and the holdover is provided by the network, the maximum absolute time error at reference point D is:

$$\max|TE_L| \leq 1350 \text{ ns}$$

The other case, where the holdover is provided by the end application, is for further study.

This requirement is only applicable in the case of a T-TSC-P external to the end application.

A first-order low-pass measurement filter with a bandwidth of 0.1 Hz is applied to the TE samples measured at the 1PPS timing interface prior to evaluating the $\max|TE|$.

NOTE – In the case that a T-BC-P is located at the end of the clock chain, where the T-TSC-P is usually located, then this network limit would also be met at the 1PPS output(s) of the T-BC-P. The T-BC-P would additionally have PTP outputs that meet the same output performance as the 1PPS, but these PTP outputs are not part of the reference models at point D of Figure 2.

Appendix I

Deployment scenarios for partial timing support networks

(This appendix does not form an integral part of this Recommendation.)

Clauses I.1 to I.6 illustrate some of the example deployment scenarios that could use the PTS and APTS architectures. It is expected that it will not be possible to meet strict timing requirements with all of these deployment scenarios.

In this appendix, the following convention is used for describing network reference points:

- Reference point A – output from the PRTC
- Reference point B – output from the T-GM or the PTP master port of an interworking function (IWF)
- Reference point C – input to the telecom time slave clock (T-TSC) or the PTP slave port of an IWF
- Reference point D – output from the T-TSC
- Reference point E – output from end application
- Reference point L – output from local time reference

For networks comprising multiple segments, an additional number is allocated denoting the network segment, and a suffix to denote the type of network segment (e.g., FTS or PTS).

It should be noted that depending on the equipment being used, reference points A and D are often internal to the equipment and may not always be accessible for measurement purposes.

I.1 APTS and PTS network use cases

The first scenario, labelled deployment case 1a, represents an APTS network (see Figure I.1). The T-TSC-A has available a local time reference (e.g., a PRTC or GNSS-based time source). This is the primary time source for synchronization. The T-TSC-A uses the PTP timing packets from the PTS network as a secondary time or frequency source for synchronization in the case of failure of the local time reference. This scenario is the one documented in clause 7.

In Figures I.1 and I.2 a T-BC-P is shown in the middle of the packet network between the T-GM and the T-TSC-A or T-TSC-P. This is optional, but may prove useful to reduce noise accumulation in the PTP timing flow. The use of the T-BC-P and its impact on the performance budget is for further study.

Similarly, a T-BC-A may also be used in the packet network in deployment case 1A. Using a T-BC-A in place of the T-TSC-A, where the PTP output port connects to the end application, is for further study.

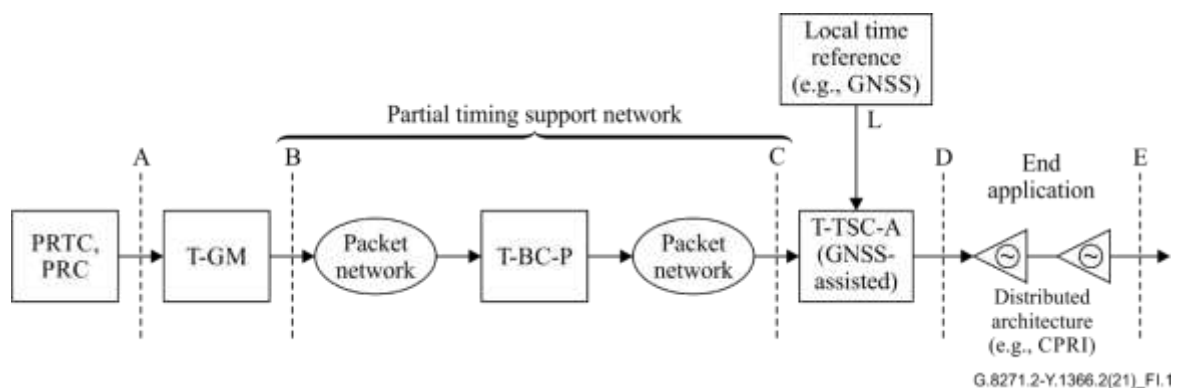

Figure I.1 – Deployment case 1a (CPRI – common public radio interface)

In some instances, the T-TSC-A and the local time reference may be integrated within the end application. In that case, the network limit for reference point C will apply at the input to the end application, and reference point D may not be externally accessible.

The second scenario, labelled deployment case 1b, represents a PTS network (see Figure I.2). The operator's time source information is provided (at interface A) using a PRTC. The timing information is sent into the PTP domain using a T-GM (at interface B). The PTP domain operates according to the [ITU-T G.8275.2] telecom profile for time/phase synchronization and contains a packet network consisting of a limited number of PTP-unaware network elements (switches/routers) and T-BC-Ps. The PTP timing information is terminated (at interface C) by a T-TSC-P and the time information is connected to the end application (at interface D).

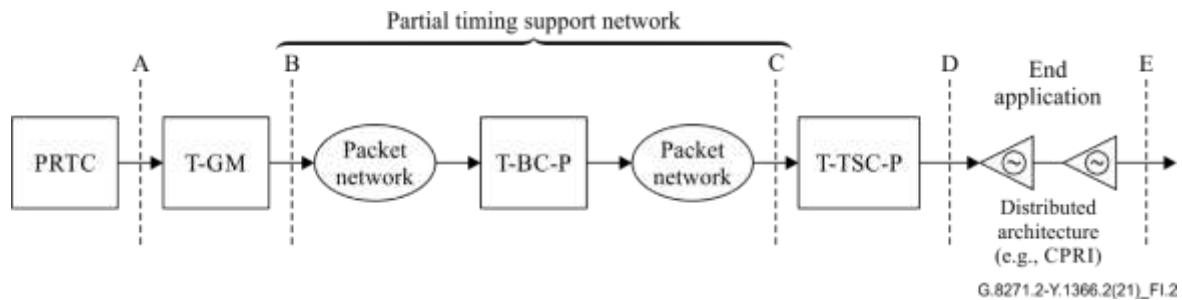

Figure I.2 – Deployment case 1b (CPRI – common public radio interface)

If the T-TSC-A is integrated within the end application, the network limit for reference point C will apply at the input to the end application, and reference point D may not be externally accessible.

I.2 Full timing support network followed by an APTS network or PTS network

In some instances, a full timing support (FTS) network (refer to [ITU-T G.8271.1]) may be deployed after the T-GM (e.g., in the core or metro network) and a PTS network may be deployed closer to the end application (in the metro or access network). This multiple-segment network approach may be used with both the APTS and PTS architectures.

The APTS case (deployment case 2a) is illustrated in Figure I.3. In this scenario, while the network limit at reference point C_{2P} may be the same as at reference point C in scenario 1a, some time error budget must be allocated to the portion of the network that is FTS (between interface B_{1F} and B_{2P}). The allocation of budget to each of the network sections is for further study.

An IWF, containing a clock among other functions, would be needed to translate from the FTS profile ([ITU-T G.8275.1]) to the PTS profile ([ITU-T G.8275.2]) going downstream from the T-GM towards the end application. This is denoted IWF F-P in Figure I.3 below. Refer to [ITU-T G.8275] Appendix III for more details on a generic IWF.

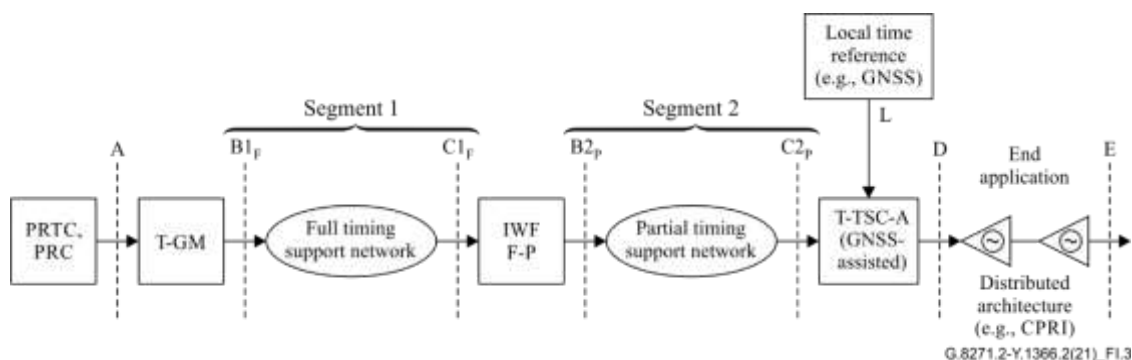

Figure I.3 – Deployment case 2a (CPRI – common public radio interface)

As noted above, the T-TSC and local time reference may be integrated into the end application, in which case reference point C2_P occurs at the input to the end application and reference point D may not be externally accessible.

Likewise, this mixture of FTS networks and PTS networks may occur with a PTS network, as illustrated in deployment case 2b shown in Figure I.4.

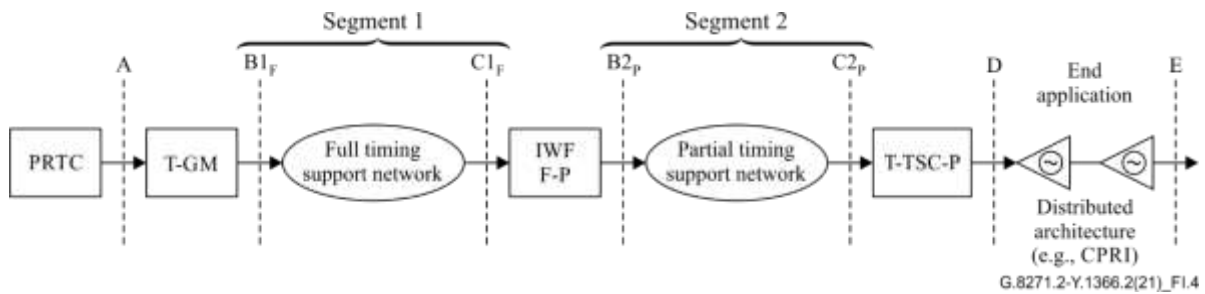

Figure I.4 – Deployment case 2b (CPRI – common public radio interface)

NOTE – In both Figures I.3 and I.4 above, an optional T-BC-P clock may be present within the PTS network segment, similar to that shown in Figures I.1 and I.2. This is not shown in the diagrams for simplicity.

I.3 PTS network followed by an FTS network

In some instances, a PTS network may be deployed after the T-GM (for example in the core or metro network) and an FTS network may be deployed closer to the end application (in the metro network, access network or radio access network (RAN) for the cases where the RAN is split based on different functions). The network limits and time error budgets associated with each section of the network are for further study.

An interworking function (IWF P-F), containing a clock among other functions, would be needed to translate from the PTS profile ([ITU-T G.8275.2]) to the FTS profile ([ITU-T G.8275.1]) going downstream from the T-GM towards the end application. This should be denoted IWF P-F. Refer to [ITU-T G.8275] Appendix III for more details on a generic IWF.

I.4 APTS network followed by a PTS network

In some instances, an APTS network may be deployed after the T-GM (e.g., in the core or metro network), with a small section using PTS closer to the end application (in the access or last-mile network). A T-BC-P assisted by a local time reference (e.g., a PRTC or GNSS time source) would be required between the two network segments.

In this scenario, some time error budget must be allocated to the portion of the network following the time-assisted network element. The network limits and time error budgets associated with each section of the network are for further study.

I.5 APTS network followed by an FTS network

In some instances, an APTS network may be deployed after the T-GM (for example in the core or metro network) and an FTS network may be deployed closer to the end application (in the metro network, access network, or RAN for the cases where the RAN is split based on different functions).

For example, as shown in Figure I.5, an interworking function (IWF P-F), containing a clock among other functions, is deployed close to the edge of the network and provides synchronization to an access segment of the network with FTS. The IWF P-F has a local time reference (e.g., a PRTC or GNSS-based time source) that is used as the primary synchronization source for the FTS network. Additionally, the IWF P-F has a secondary synchronization source from the PTS network that may be used by the IWF P-F according to the APTS scheme. The IWF P-F would need to translate from the PTS profile

([ITU-T G.8275.2]) to the FTS profile ([ITU-T G.8275.1]) going downstream from the T-GM towards the end application.

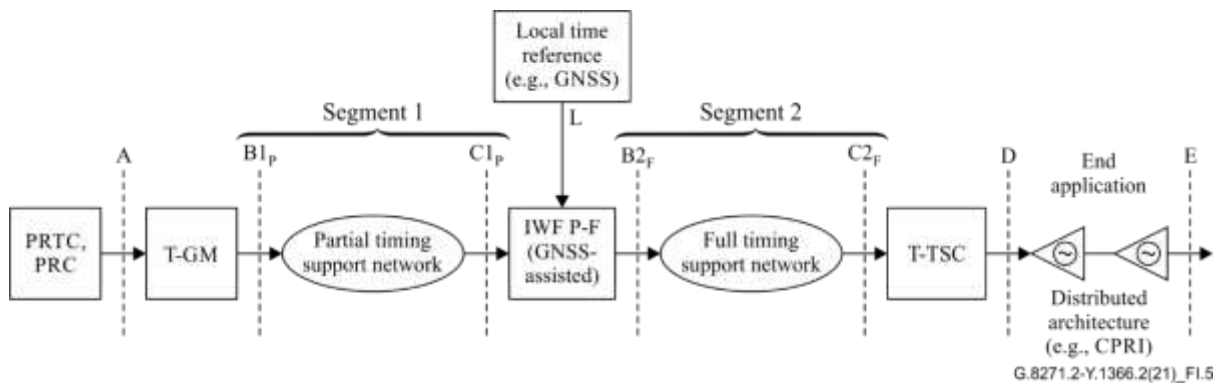

Figure I.5 – APTS network followed by a full timing support network (CPRI – common public radio interface)

The network limits and time error budgets associated with each section of the network are for further study, but the noise accumulation over all the segments up to point C2_F, including the IWFs, should stay within the overall network limit defined for reference point C in clause 7.3.

The time error budget allocated to the FTS network (between reference points B2_F and C2_F in Figure I.5 above) is expected to be relatively small, in order to not significantly reduce the time error budget allocated to the PTS segment, while also allowing a few (e.g., 2 to 3) PTP-aware network elements to be present in the FTS segment. An FTS time error budget of the order of 200 ns (in terms of max|TE| between reference points B2_F and C2_F) could address several use cases of interest. For further information on how to meet this budget refer to Appendix V in [ITU-T G.8271.1].

I.6 Use of PTS network to bridge between two FTS networks

In some circumstances, an operator deploying an FTS architecture has to connect two network segments over a PTP-unaware network segment owned or operated by a third party operator. In this case, it may be necessary to use PTS across the third party network. The network limits and time error budgets associated with each section of the network are for further study.

Figure I.6 illustrates the concept. An interworking function (IWF F-P), containing a clock among other functions, is needed to translate from the FTS profile ([ITU-T G.8275.1]) to the PTS profile ([ITU-T G.8275.2]) going downstream from the T-GM towards the end application.

A second interworking function (IWF P-F), containing a clock among other functions, is needed to translate from the PTS profile ([ITU-T G.8275.2]) back to the FTS profile ([ITU-T G.8275.1]) going downstream from the T-GM towards the end application.

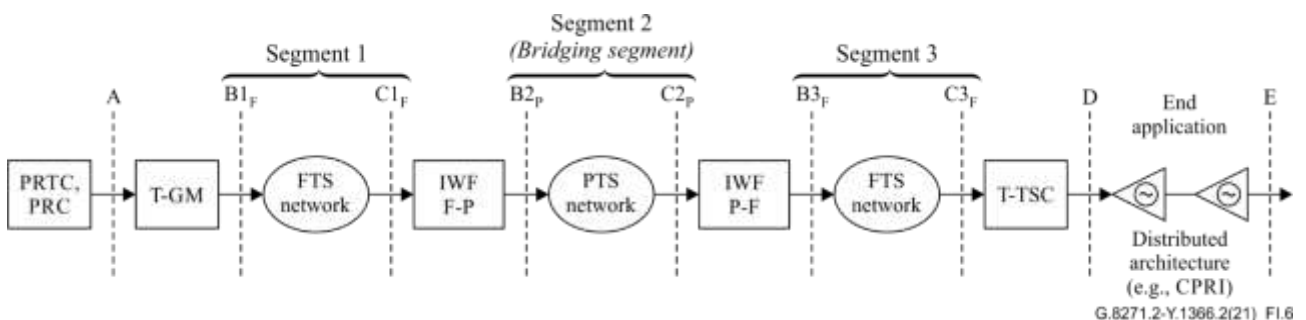

Figure I.6 – Bridging across a PTS network (CPRI – common public radio interface)

Appendix II

Considerations for handling precision time protocol traffic in networks with partial timing support

(This appendix does not form an integral part of this Recommendation.)

In order to meet the stringent network limits specified in this Recommendation, careful planning is needed in order to control the PDV and delay asymmetry generated by the network. Such a controlled network would typically be a small-scale, local network (e.g., in-building or "last-mile" network segments, such as might be used for the connection of small cells).

These guidelines are related to meeting the network limit of 1.1 μs at reference point C. This is necessary to meet the end application requirement of a maximum absolute time error of 1.5 μs (Class 4 in [ITU-T G.8271], Table 1). In cases where the end application requirements are less stringent (e.g., Class 2), the requirements on the network PDV and asymmetry are more relaxed. The details are for further study.

II.1 Network aspects

The following aspects should be considered.

- 1) The asymmetry and PDV generated by the network elements under applicable conditions should be characterized and validated. Such conditions should include:
 - a) dynamic traffic load and frame lengths;
 - b) network congestion;
 - c) link failure and restoration;
 - d) network element power cycle;
 - e) network reroute of PTP packets.
- 2) It is recommended that PTP messages be assigned to a high quality of service in order to reduce the PDV created by other data carried over the network. However, it should be noted that even if PTP messages use the highest quality of service, they may not avoid all PDV due to effects including head of line blocking, queuing architectures and others. The details are described in Appendix I of [b-ITU-T G.8261].
- 3) The link technology should not create excessive asymmetry or PDV.
- 4) Where possible, interface rate changes should be signalled by use of the INTERFACE_RATE type length variable (TLV) defined in Annex D of [ITU-T G.8275.2]. This allows the delay asymmetry caused by the rate change to be compensated for. If the equipment does not support the INTERFACE_RATE TLV, the effect of the asymmetry must be carefully considered.
- 5) The use of boundary clocks at key locations may be useful to reduce the accumulation of PDV. For example, a new network element containing a boundary clock between the PTP master and PTP slave(s) may be added. This is for further study.
- 6) The replacement of existing PTP-unaware network elements with network elements containing boundary clocks or transparent clocks would reduce the internal asymmetry and PDV introduced by the replaced network element, and additionally the boundary clock may be useful to reduce the overall accumulation of PDV.

The network should be based on a very small number of PTP-unaware network elements. The number is strongly related to the specific network equipment, the transport technology and the management and control of the traffic load in the network. It should be noted that not all switching and routing technology is the same, and this can affect the level of PDV and delay asymmetry produced. Switches and routers

have their own specific characteristics depending on their internal implementation. Some more complex network elements generate higher levels of PDV and asymmetry than smaller ones.

Some trials have reported successful operation over three to five PTP-unaware network elements where the traffic load and asymmetry were well-controlled; other trials have reported poor performance even over one PTP-unaware network element. Depending on the specific characteristics of the network elements used, and the traffic load within the network, the network may not support time or phase synchronization using PTS.

In addition, conditions in a network may change over time, e.g., as traffic load changes or as network asymmetry changes (this may occur in some technologies such as the optical transport network). Therefore one single measurement is not sufficient to fully characterize a network. Network monitoring is recommended to ensure the network limits are consistently met.

II.2 Time error performance aspects

For APTS networks, it is the dTE created by the PDV in the network that is of interest. The cTE created by delay asymmetry in the network should be sufficiently stable, relative to the required performance. If this is met, the local time reference of the T-TSC-A may be used to compensate for the asymmetry created by the network. Compensation may be achieved by either:

- 1) measuring the delay asymmetry while the local time reference is in operation, such that it is known in advance if the local time reference fails;
- 2) setting the correct time while the local time reference is in operation, and using the PTP flow as a source of frequency to maintain the time base when the local time reference is out of service.

For PTS networks, the full time error created by the network is important, including both the cTE and dTE components. This is because there is no local time reference to compensate for the network delay asymmetry.

Appendix III

The use of frequency to maintain precise time

(This appendix does not form an integral part of this Recommendation.)

Frequency, which can be used to hold precise time, can be derived from PTP. Further, in the case of PTP derived frequency, it is possible to derive frequency using packets from a single direction. Thus, for frequency from PTP, three approaches are possible:

- 1) use of the forward sequence;
- 2) use of the reverse sequence;
- 3) use of both the forward and reverse sequences together.

In cases where one of the two sequences shows much less PDV than the other, focus on that sequence rather than on both is warranted. Such a situation is illustrated in Figure III.1.

The limits for APTS are based on a peak-to-peak value of `pktSelected2WayTE`. In Appendix I of [ITU-T G.8260], the `pktSelected2WayTE`, expressed as $x_c'(t)$, is described by Figure III.1.

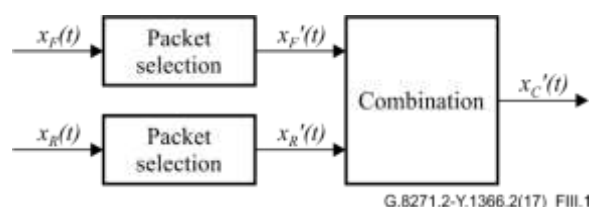

Figure III.1 – Packet Selection

Note that the packet selection is done independently on each one-way sequence with the results combined in each selection window. Thus the forward and reverse sequences are *both* constrained at the same time for each window.

For APTS, time is normally supplied by GNSS, and in the event of GNSS loss turns to PTP to provide or hold time. Time can be maintained by stable frequency, particularly over short periods of time such as small multiples of the 100 s or 200 s selection windows described above. The source of stable frequency might be an internal oscillator in the APTS clock, a traceable frequency input such as from SyncE, or a frequency derived from PTP.

The ability of a local oscillator to hold time is illustrated in Table III.1.

Table III.1 – Local oscillator types and phase drift

	10 ns	50 ns	100 ns	500 ns	1 μs
ITU-T G.812 Type 1	0.22 h	0.50 h	0.70 h	1.57 h	2.22 h
ITU-T G.812 Type 2	1.15 h	2.58 h	3.65 h	8.16 h	11.55 h
ITU-T G.812 Type 4	0.11 h	0.24 h	0.33 h	0.75 h	1.05 h
ITU-T G.812 Type 4	1.11 min	2.48 min	3.51 min	7.84 min	11.09 min
ITU-T G.812 Type 5	0.30 h	0.67 h	0.94 h	2.11 h	2.98 h
ITU-T G.812 Type 6	4.00 min	8.94 min	12.65 min	28.28 min	40.00 min
ITU-T Opt 1	0.49 min	1.10 min	1.55 min	3.46 min	4.90 min
ITU-T Opt 2	0.32 min	0.72 min	1.02 min	2.28 min	3.23 min

The ability of a traceable frequency to hold time is illustrated in Table III.2.

Table III.2 – Traceable frequency phase drift

	10 ns	50 ns	100 ns	1 μs	10 μs
Caesium (1E-12)	2.8 h	13.9 h	27.8 h	11.6 days	115.7 days
ITU-T G.811 (1E-11)	16.7 min	1.4 h	2.8 h	1.2 days	11.6 days

In the case of frequency derived from PTP, there are fairly common situations where stable frequency can be easily attained from PTP, though precise time is attained with greater difficulty. Such a situation is exemplified by Figure III.2, where blue shows the forward packet sequence and red shows the reverse packet sequence.

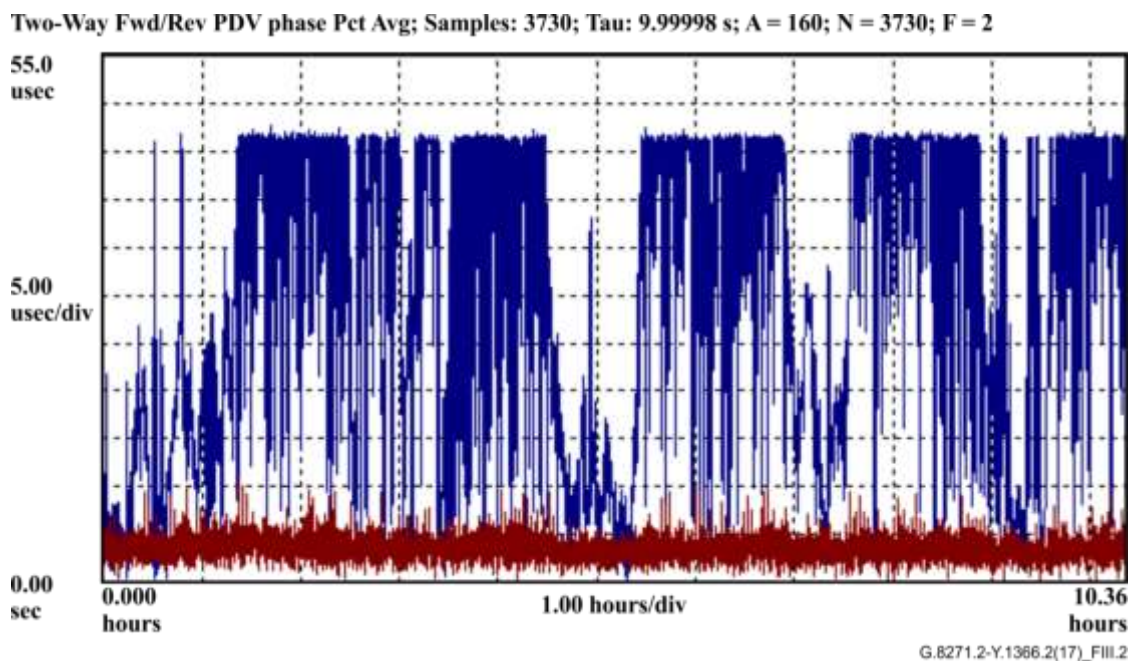

Figure III.2 – Examples of forward and reverse packet sequences

In this case, focusing on the reverse packets would yield a better frequency result.

Further, there are times when the forward sequence is advantageous for holding time and other times, perhaps just a short time later, when the reverse sequence is advantageous for holding time. Perhaps in a series of 10 selection windows, 1-3 are better for forward, 4-7 better for reverse and 8-10 better for forward.

Thus, while the limit based on peak-to-peak pktSelected2WayTE can suitably guarantee the presence of network conditions for APTS devices to deliver proper synchronization, a single one-way sequence can provide a stable frequency that can be used to assist in holding precise time.

Appendix IV

Noise accumulation model in partially aware networks

(This appendix does not form an integral part of this Recommendation.)

A partially aware network may contain several PTS clocks before the synchronization reaches the end application. Such a situation is illustrated in Figure IV.1, where there is one T-BC-P and one T-TSC-P in the synchronization chain. The accumulated time error accumulation is a function of the network PDV (as expressed in the metric $\max|\text{pktSelected2wayTE}|$), the transfer function of the PTS clock (expressed in terms of "gain peaking"), and the noise generation of the PTS clock.

In the example below, the time error on the PTP input interface at point P2 is X ns, as expressed using the $\max|\text{pktSelected2wayTE}|$ metric. The time error on the output from the T-BC-P at point P3 is $(X + \text{Gain} + \text{Generation})$, as expressed using $\max|\text{TE}|$.

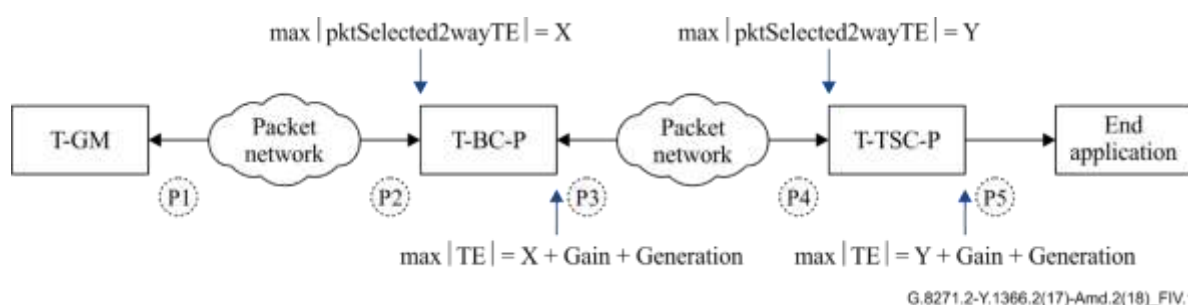

Figure IV.1 – Example network showing noise accumulation model

The way these different parameters combine is for further study.

Note that while this example shows the network limit using pktSelected2wayTE , an implementation of a T-BC-P or T-TSC-P may use any number of design (selection, filtering) techniques not related to the network limit metric. Implementations may achieve better performance than shown in the example.

Bibliography

- [b-ITU-T G.8261] Recommendation ITU-T G.8261/Y.1361 (2020), *Timing and synchronization aspects in packet networks*.

ITU-T Y-SERIES RECOMMENDATIONS
**GLOBAL INFORMATION INFRASTRUCTURE, INTERNET PROTOCOL ASPECTS, NEXT-
GENERATION NETWORKS, INTERNET OF THINGS AND SMART CITIES**

GLOBAL INFORMATION INFRASTRUCTURE	
General	Y.100–Y.199
Services, applications and middleware	Y.200–Y.299
Network aspects	Y.300–Y.399
Interfaces and protocols	Y.400–Y.499
Numbering, addressing and naming	Y.500–Y.599
Operation, administration and maintenance	Y.600–Y.699
Security	Y.700–Y.799
Performances	Y.800–Y.899
INTERNET PROTOCOL ASPECTS	
General	Y.1000–Y.1099
Services and applications	Y.1100–Y.1199
Architecture, access, network capabilities and resource management	Y.1200–Y.1299
Transport	Y.1300–Y.1399
Interworking	Y.1400–Y.1499
Quality of service and network performance	Y.1500–Y.1599
Signalling	Y.1600–Y.1699
Operation, administration and maintenance	Y.1700–Y.1799
Charging	Y.1800–Y.1899
IPTV over NGN	Y.1900–Y.1999
NEXT GENERATION NETWORKS	
Frameworks and functional architecture models	Y.2000–Y.2099
Quality of Service and performance	Y.2100–Y.2199
Service aspects: Service capabilities and service architecture	Y.2200–Y.2249
Service aspects: Interoperability of services and networks in NGN	Y.2250–Y.2299
Enhancements to NGN	Y.2300–Y.2399
Network management	Y.2400–Y.2499
Computing power networks	Y.2500–Y.2599
Packet-based Networks	Y.2600–Y.2699
Security	Y.2700–Y.2799
Generalized mobility	Y.2800–Y.2899
Carrier grade open environment	Y.2900–Y.2999
FUTURE NETWORKS	Y.3000–Y.3499
CLOUD COMPUTING	Y.3500–Y.3599
BIG DATA	Y.3600–Y.3799
QUANTUM KEY DISTRIBUTION NETWORKS	Y.3800–Y.3999
INTERNET OF THINGS AND SMART CITIES AND COMMUNITIES	
General	Y.4000–Y.4049
Definitions and terminologies	Y.4050–Y.4099
Requirements and use cases	Y.4100–Y.4249
Infrastructure, connectivity and networks	Y.4250–Y.4399
Frameworks, architectures and protocols	Y.4400–Y.4549
Services, applications, computation and data processing	Y.4550–Y.4699
Management, control and performance	Y.4700–Y.4799
Identification and security	Y.4800–Y.4899
Evaluation and assessment	Y.4900–Y.4999

For further details, please refer to the list of ITU-T Recommendations.

SERIES OF ITU-T RECOMMENDATIONS

Series A	Organization of the work of ITU-T
Series D	Tariff and accounting principles and international telecommunication/ICT economic and policy issues
Series E	Overall network operation, telephone service, service operation and human factors
Series F	Non-telephone telecommunication services
Series G	Transmission systems and media, digital systems and networks
Series H	Audiovisual and multimedia systems
Series I	Integrated services digital network
Series J	Cable networks and transmission of television, sound programme and other multimedia signals
Series K	Protection against interference
Series L	Environment and ICTs, climate change, e-waste, energy efficiency; construction, installation and protection of cables and other elements of outside plant
Series M	Telecommunication management, including TMN and network maintenance
Series N	Maintenance: international sound programme and television transmission circuits
Series O	Specifications of measuring equipment
Series P	Telephone transmission quality, telephone installations, local line networks
Series Q	Switching and signalling, and associated measurements and tests
Series R	Telegraph transmission
Series S	Telegraph services terminal equipment
Series T	Terminals for telematic services
Series U	Telegraph switching
Series V	Data communication over the telephone network
Series X	Data networks, open system communications and security
Series Y	Global information infrastructure, Internet protocol aspects, next-generation networks, Internet of Things and smart cities
Series Z	Languages and general software aspects for telecommunication systems