

ITU-T

G.8273.2/Y.1368.2

TELECOMMUNICATION
STANDARDIZATION SECTOR
OF ITU

(01/2017)

SERIES G: TRANSMISSION SYSTEMS AND MEDIA,
DIGITAL SYSTEMS AND NETWORKS

Packet over Transport aspects – Synchronization, quality
and availability targets

SERIES Y: GLOBAL INFORMATION
INFRASTRUCTURE, INTERNET PROTOCOL ASPECTS,
NEXT-GENERATION NETWORKS, INTERNET OF
THINGS AND SMART CITIES

Internet protocol aspects – Transport

**Timing characteristics of telecom boundary
clocks and telecom time slave clocks**

Recommendation ITU-T G.8273.2/Y.1368.2

ITU-T G-SERIES RECOMMENDATIONS

TRANSMISSION SYSTEMS AND MEDIA, DIGITAL SYSTEMS AND NETWORKS

INTERNATIONAL TELEPHONE CONNECTIONS AND CIRCUITS	G.100–G.199
GENERAL CHARACTERISTICS COMMON TO ALL ANALOGUE CARRIER-TRANSMISSION SYSTEMS	G.200–G.299
INDIVIDUAL CHARACTERISTICS OF INTERNATIONAL CARRIER TELEPHONE SYSTEMS ON METALLIC LINES	G.300–G.399
GENERAL CHARACTERISTICS OF INTERNATIONAL CARRIER TELEPHONE SYSTEMS ON RADIO-RELAY OR SATELLITE LINKS AND INTERCONNECTION WITH METALLIC LINES	G.400–G.449
COORDINATION OF RADIOTELEPHONY AND LINE TELEPHONY	G.450–G.499
TRANSMISSION MEDIA AND OPTICAL SYSTEMS CHARACTERISTICS	G.600–G.699
DIGITAL TERMINAL EQUIPMENTS	G.700–G.799
DIGITAL NETWORKS	G.800–G.899
DIGITAL SECTIONS AND DIGITAL LINE SYSTEM	G.900–G.999
MULTIMEDIA QUALITY OF SERVICE AND PERFORMANCE – GENERIC AND USER-RELATED ASPECTS	G.1000–G.1999
TRANSMISSION MEDIA CHARACTERISTICS	G.6000–G.6999
DATA OVER TRANSPORT – GENERIC ASPECTS	G.7000–G.7999
PACKET OVER TRANSPORT ASPECTS	G.8000–G.8999
Ethernet over Transport aspects	G.8000–G.8099
MPLS over Transport aspects	G.8100–G.8199
Synchronization, quality and availability targets	G.8200–G.8299
Service Management	G.8600–G.8699
ACCESS NETWORKS	G.9000–G.9999

For further details, please refer to the list of ITU-T Recommendations.

Recommendation ITU-T G.8273.2/Y.1368.2

Timing characteristics of telecom boundary clocks and telecom time slave clocks

Summary

Recommendation ITU-T G.8273.2/Y.1368.2 specifies minimum requirements for time and phase for telecom boundary clocks and telecom time slave clocks used in synchronization network equipment that operates in the network architecture as defined in Recommendations ITU-T G.8271, ITU-T G.8271.1, ITU-T G.8275 and ITU-T G.8275.1. It supports time and/or phase synchronization distribution for packet based networks.

This version of the Recommendation only applies to full timing support from the network.

These requirements apply under the normal environmental conditions specified for the equipment.

History

Edition	Recommendation	Approval	Study Group	Unique ID*
1.0	ITU-T G.8273.2/Y.1368.2	2014-05-14	15	11.1002/1000/12196
1.1	ITU-T G.8273.2/Y.1368.2 (2014) Amd. 1	2015-01-13	15	11.1002/1000/12395
1.2	ITU-T G.8273.2/Y.1368.2 (2014) Amd. 2	2015-08-13	15	11.1002/1000/12543
2.0	ITU-T G.8273.2/Y.1368.2	2017-01-12	15	11.1002/1000/13109

Keywords

Boundary clock, frequency synchronization, phase synchronization, slave clock, synchronous Ethernet, time synchronization.

* To access the Recommendation, type the URL <http://handle.itu.int/> in the address field of your web browser, followed by the Recommendation's unique ID. For example, <http://handle.itu.int/11.1002/1000/11830-en>.

FOREWORD

The International Telecommunication Union (ITU) is the United Nations specialized agency in the field of telecommunications, information and communication technologies (ICTs). The ITU Telecommunication Standardization Sector (ITU-T) is a permanent organ of ITU. ITU-T is responsible for studying technical, operating and tariff questions and issuing Recommendations on them with a view to standardizing telecommunications on a worldwide basis.

The World Telecommunication Standardization Assembly (WTSA), which meets every four years, establishes the topics for study by the ITU-T study groups which, in turn, produce Recommendations on these topics.

The approval of ITU-T Recommendations is covered by the procedure laid down in WTSA Resolution 1.

In some areas of information technology which fall within ITU-T's purview, the necessary standards are prepared on a collaborative basis with ISO and IEC.

NOTE

In this Recommendation, the expression "Administration" is used for conciseness to indicate both a telecommunication administration and a recognized operating agency.

Compliance with this Recommendation is voluntary. However, the Recommendation may contain certain mandatory provisions (to ensure, e.g., interoperability or applicability) and compliance with the Recommendation is achieved when all of these mandatory provisions are met. The words "shall" or some other obligatory language such as "must" and the negative equivalents are used to express requirements. The use of such words does not suggest that compliance with the Recommendation is required of any party.

INTELLECTUAL PROPERTY RIGHTS

ITU draws attention to the possibility that the practice or implementation of this Recommendation may involve the use of a claimed Intellectual Property Right. ITU takes no position concerning the evidence, validity or applicability of claimed Intellectual Property Rights, whether asserted by ITU members or others outside of the Recommendation development process.

As of the date of approval of this Recommendation, ITU had not received notice of intellectual property, protected by patents, which may be required to implement this Recommendation. However, implementers are cautioned that this may not represent the latest information and are therefore strongly urged to consult the TSB patent database at <http://www.itu.int/ITU-T/ipr/>.

© ITU 2017

All rights reserved. No part of this publication may be reproduced, by any means whatsoever, without the prior written permission of ITU.

Table of Contents

		Page
1	Scope.....	1
2	References.....	1
3	Definitions	2
	3.1 Terms defined elsewhere	2
	3.2 Terms defined in this Recommendation.....	2
4	Abbreviations and acronyms	2
5	Conventions	3
6	Physical layer frequency performance requirements.....	3
7	T-BC packet layer performance requirements for full timing support from the network	3
	7.1 Constant time error and dynamic time error noise generation	4
	7.2 Noise tolerance	6
	7.3 Noise transfer.....	6
	7.4 Transient response and holdover performance.....	7
	7.5 Interfaces	9
	Annex A – Telecom boundary clock model	11
	Annex B – Control of the phase transient due to rearrangements in the synchronous Ethernet network.....	13
	Annex C – Telecom time slave clock requirements	15
	C.1 Physical layer frequency performance requirements	15
	C.2 T-TSC packet layer performance requirements for full timing support from the network	15
	Appendix I – Mitigation of time error due to SyncE/SDH transients.....	22
	Appendix II – Derivation of T-BC output transient mask due to SyncE/SDH rearrangement	23
	II.1 Background on assumptions for and derivation of T-BC output phase error due to a SyncE/SDH rearrangement	23
	II.2 T-BC output phase transient mask	30
	Appendix III – Background to performance requirements of the T-BC.....	33
	III.1 Noise generation requirements	34
	III.2 Noise tolerance	34
	III.3 Noise transfer.....	35
	III.4 Holdover	37
	Appendix IV – Consideration on slave clocks embedded in end applications	39
	Appendix V – Performance Estimation for Cascaded Media Converters acting as T-BCs.....	40
	V.1 Noise generation.....	40
	V.2 Noise tolerance	41
	V.3 Noise transfer.....	41
	V.4 Transient response and holdover performance.....	41

Recommendation ITU-T G.8273.2/Y.1368.2

Timing characteristics of telecom boundary clocks and telecom time slave clocks

1 Scope

This Recommendation specifies minimum requirements for time and phase synchronization devices used in synchronization network equipment that operates in the network architecture as defined in [ITU-T G.8271], [ITU-T G.8271.1] and [ITU-T G.8275]. It supports time and/or phase synchronization distribution for packet based networks.

This Recommendation allows for proper network operation for phase/time synchronization distribution when network equipment embedding a telecom boundary clock (T-BC) and telecom time slave clock (T-TSC) is timed from another T-BC or a telecom grandmaster (T-GM). The current version of this Recommendation addresses only the distribution of phase/time synchronization with the full timing support architecture defined in [ITU-T G.8275] and the related profile defined in [ITU-T G.8275.1]. The definition of a T-BC and the T-TSC for the future partial timing support architecture is for further study.

This Recommendation defines the minimum requirements for telecom boundary clocks and telecom time slave clocks in network elements. These requirements apply under the normal environmental conditions specified for the equipment. The current version of this Recommendation focuses on the case of physical layer frequency support. Requirements related to the case without physical layer frequency support (i.e., the pure PTP case) are for further study.

This Recommendation includes noise generation, noise tolerance, noise transfer and transient response for telecom boundary clocks and telecom time slave clocks.

This version of the Recommendation was developed based on the simulations done for time transport via precision time protocol (PTP) and frequency transport via [ITU-T G.8262] EEC-Option 1 (and [ITU-T G.813] SEC-Option 1 as the requirements are identical). [ITU-T G.8262] EEC-Option 2 and [ITU-T G.813] SEC-Option 2 are for further study.

The T-BC requirements are given in clauses 6 and 7 and the T-TSC requirements are given in annex C.

NOTE – This Recommendation does not modify the physical layer reference chain behaviour, according to [ITU-T G.803] and [ITU-T G.8261]. This Recommendation does not exclude the use of other physical layer clocks (e.g., [ITU-T G.812] Type I) within the frequency transport network. The equipment specification of a T-BC assisted by a physical layer equipment clock, other than [ITU-T G.8262] option 1, such as [ITU-T G.812] Type I, is for further study.

2 References

The following ITU-T Recommendations and other references contain provisions which, through reference in this text, constitute provisions of this Recommendation. At the time of publication, the editions indicated were valid. All Recommendations and other references are subject to revision; users of this Recommendation are therefore encouraged to investigate the possibility of applying the most recent edition of the Recommendations and other references listed below. A list of the currently valid ITU-T Recommendations is regularly published. The reference to a document within this Recommendation does not give it, as a stand-alone document, the status of a Recommendation.

[ITU-T G.703] Recommendation ITU-T G.703 (2016), *Physical/electrical characteristics of hierarchical digital interfaces*.

[ITU-T G.781] Recommendation ITU-T G.781 (2008), *Synchronization layer functions*.

- [ITU-T G.803] Recommendation ITU-T G.803 (2000), *Architecture of transport networks based on the synchronous digital hierarchy (SDH)*.
- [ITU-T G.810] Recommendation ITU-T G.810 (1996), *Definitions and terminology for synchronization networks*.
- [ITU-T G.812] Recommendation ITU-T G.812 (2004), *Timing requirements of slave clocks suitable for use as node clocks in synchronization networks*.
- [ITU-T G.813] Recommendation ITU-T G.813 (2003), *Timing characteristics of SDH equipment slave clocks (SEC)*.
- [ITU-T G.8260] Recommendation ITU-T G.8260 (2015), *Definitions and terminology for synchronization in packet networks*.
- [ITU-T G.8261] Recommendation ITU-T G.8261/Y.1361 (2013), *Timing and synchronization in packet networks*.
- [ITU-T G.8262] Recommendation ITU-T G.8262/Y.1362 (2015), *Timing characteristics of a synchronous Ethernet equipment slave clock*.
- [ITU-T G.8264] Recommendation ITU-T G.8264/Y.1364 (2014), *Distribution of timing information through packet networks*.
- [ITU-T G.8271] Recommendation ITU-T G.8271/Y.1366 (2016), *Time and phase synchronization aspects of packet networks*.
- [ITU-T G.8271.1] Recommendation ITU-T G.8271.1/Y.1366.1 (2013), *Network limits for time synchronization in packet networks*.
- [ITU-T G.8273] Recommendation ITU-T G.8273/Y.1368 (2013), *Framework of phase and time clocks*.
- [ITU-T G.8275] Recommendation ITU-T G.8275/Y.1369 (2013), *Architecture and requirements for packet-based time and phase distribution*.
- [ITU-T G.8275.1] Recommendation ITU-T G.8275.1/Y.1369.1 (2016), *Precision time protocol telecom profile for phase/time synchronization with full timing support from the network*.

3 Definitions

3.1 Terms defined elsewhere

This Recommendation uses the following terms defined elsewhere:

Definitions related to synchronization are contained in [ITU-T G.810] and [ITU-T G.8260].

3.2 Terms defined in this Recommendation

None.

4 Abbreviations and acronyms

This Recommendation uses the following abbreviations and acronyms:

cTE	Constant Time Error
dTE	Dynamic Time Error
EEC	synchronous Ethernet Equipment Clock
ESMC	Ethernet Synchronization Messaging Channel

GbE	Gigabit Ethernet
MTIE	Maximum Time Interval Error
NE	Network Element
PEC	Packet-based Equipment Clock
PPS	Pulse Per Second
PRC	Primary Reference Clock
PRTC	Primary Reference Time Clock
PTP	Precision Time Protocol
SDH	Synchronous Digital Hierarchy
SEC	SDH equipment slave clock
SSM	Synchronization Status Message
SyncE	Synchronous Ethernet
T-BC	Telecom Boundary Clock
TDEV	Time Deviation
TE	Time Error
ToD	Time of Day
T-GM	Telecom Grandmaster
T-TSC	Telecom Time Slave Clock

5 Conventions

None.

6 Physical layer frequency performance requirements

The list of the applicable physical layer frequency interfaces is provided in clause 7.5.2.

The following applies for the synchronous Ethernet and SDH interfaces:

Synchronous Ethernet (SyncE) interfaces and synchronous Ethernet equipment clocks (EECs) used in combination with the telecom boundary clock (T-BC) are specified in [ITU-T G.8262] and generate and process Ethernet synchronization messaging channel (ESMC) messages as specified in [ITU-T G.8264].

Synchronous digital hierarchy (SDH) interfaces and SDH equipment slave clocks (SECs) used in combination with the T-BC are specified in [ITU-T G.813] and generate and process synchronization status messages (SSMs) as specified in [ITU-T G.781].

NOTE – The ITU-T G.8273.2 T-BC model does not exclude the use of other physical layer clocks (e.g., [ITU-T G.812] Type I) within the equipment related to the operation between the physical layer input to physical layer output interface behaviour, in accordance to the existing [ITU-T G.803] reference chain and [ITU-T G.8261] network limits. In such cases, the equipment behaviour related to the interaction between the physical layer input and the PTP output is for further study.

7 T-BC packet layer performance requirements for full timing support from the network

See Appendix III for background information on performance requirements of the T-BC.

NOTE – The 1 PPS input pertains to telecom grand master functions and it is for further study.

7.1 Constant time error and dynamic time error noise generation

The noise generation of a T-BC represents the amount of noise produced at the output of the T-BC when there is an ideal input reference packet timing signal.

Under normal, locked operating conditions, the time output of the T-BC should be accurate to within the maximum absolute time error (TE) ($\max|TE|$). This value includes all the noise components, i.e., the constant time error (cTE) and the dynamic time error (dTE) noise generation.

In order to support different performance requirements at the end application specified in Table 1 of [ITU-T G.8271] using different network topologies and network technologies, the maximum absolute time error, the time error and dTE noise generation requirements for T-BCs are divided into two classes: Class A and Class B.

At the precision time protocol (PTP) and 1 pulse per second (PPS) outputs, the maximum absolute time error ($\max|TE|$) for Class A and Class B is shown in Table 7-1. This includes all time error components (unfiltered).

Table 7-1 – Maximum absolute time error ($\max|TE|$)

T-BC class	Maximum absolute time error – $\max TE $ (ns)
A	100 ns
B	70 ns

NOTE – The values in Table 7-1 are valid for 1 PPS, 1 gigabit Ethernet (GbE) and 10 GbE interfaces. Values for interfaces above 10 GbE or below 1 GbE are for further study.

The noise generation is divided into two components, the cTE and the dTE noise generation.

7.1.1 Constant time error generation

At the PTP and 1 PPS outputs, the cTE generation for Class A and Class B is shown in Table 7-2.

Table 7-2 – T-BC permissible range of constant time error

T-BC Class	Permissible range of constant time error – cTE(ns)
A	± 50
B	± 20

NOTE 1 – The values in Table 7-2 are valid for 1 PPS, 1 GbE and 10 GbE interfaces. Values for interfaces above 10 GbE or below 1 GbE are for further study.

NOTE 2 – Constant time error definition and the method to estimate constant time error are defined in [ITU-T G.8260]. For the purpose of testing the limits in Table 7-2, an estimate of constant time error should be obtained by averaging the time error sequence over 1 000 s.

7.1.2 Dynamic time error low-pass filtered noise generation (dTE_L)

For a T-BC Class A or Class B containing an EEC-Option 1 clock and operating in locked mode synchronized to both a wander-free time reference at the PTP input and a wander-free frequency reference at the physical layer frequency input, the maximum time interval error (MTIE) at the PTP and 1 PPS outputs, measured through a first-order low-pass filter with bandwidth of 0.1 Hz, should meet the limits in Table 7-3 under constant temperature (within ± 1 K).

Table 7-3 – Dynamic time error low-pass filtered noise generation (MTIE) for T-BC with constant temperature

MTIE limit [ns]	Observation interval τ [s]
40	$m < \tau \leq 1\ 000$ (Notes 1, 2)
NOTE 1 – The minimum τ value m is determined by packet rate of 16 packet per second ($m=1/16$) or 1 PPS signal ($m=1$).	
NOTE 2 – The values in this table are valid for 1 PPS, 1 GbE and 10 GbE interfaces. Values for interface rates above 10 GbE or below 1 GbE are for further study.	

When temperature effects are included, the MTIE requirement is defined in Table 7-4 for a T-BC with physical layer frequency support; in this case the maximum observation interval is increased to 10 000 s.

Table 7-4 – Dynamic time error low-pass filtered noise generation (MTIE) for T-BC with variable temperature

MTIE limit [ns]	Observation interval τ [s]
40	$m < \tau \leq 10\ 000$ (Notes 1, 2)
NOTE 1 – the minimum τ value m is determined by packet rate of 16 packet per second ($m=1/16$) or 1 PPS signal ($m=1$).	
NOTE 2 – the values in this table are valid for 1 PPS, 1 GbE and 10 GbE interfaces. Values for interfaces above 10 GbE and below 1 GbE are for further study.	

NOTE – Guidelines for variable temperature testing are described in Appendix I of [ITU-T G.8273].

For a Class A or Class B T-BC containing an EEC-Option 1 clock and operating in locked mode synchronized to both a wander-free time reference at the PTP input and a wander-free frequency reference at the physical layer frequency input, the TDEV at the PTP and 1 PPS outputs, measured through a first-order low-pass filter with bandwidth of 0.1 Hz, should meet the limits shown in Table 7-5 under constant temperature (within $\pm 1\text{K}$).

Table 7-5 – Dynamic time error low-pass filtered noise generation (TDEV) for T-BC with constant temperature

TDEV limit [ns]	Observation interval τ [s]
4	$m < \tau \leq 1\ 000$ (Notes 1, 2)
NOTE 1 – The minimum τ value m is determined by packet rate of 16 packet per second ($m=1/16$) or 1 PPS signal ($m=1$)	
NOTE 2 – The values in this table are valid for 1 PPS, 1 GbE and 10 GbE interfaces. Values for interfaces above 10 GbE and below 1 GbE are for further study.	

7.1.3 Dynamic time error high-pass filtered noise generation (dTE_H)

For a T-BC Class A or Class B containing an EEC-Option 1 clock and operating in a locked mode synchronized to both a noise-free time reference at the PTP input and a noise-free frequency reference at the physical layer frequency input, the peak-to-peak time error at the T-BC output interfaces, measured over a 1 000 second measurement interval, with a first-order high-pass filter of 0.1 Hz must be less than 70 ns.

NOTE – The value of 70 ns is a conservative limit based on the SEC/EEC noise generation specification. This is based on the assumption that most of this noise is generated by the high-pass filtered noise of the SEC/EEC oscillator. It is expected that implementations based on better clocks can result in significantly lower values. It is not intended and not assumed that the component of the high-pass filtered noise due to timestamp granularity is a major portion of the 70 ns.

7.2 Noise tolerance

The noise tolerance of a T-BC indicates the minimum dynamic time error level at the input of the clock that should be accommodated while:

- not causing any alarms;
- not causing the clock to switch reference;
- not causing the clock to go into holdover.

NOTE 1 – There is no requirement related to cTE tolerance.

A T-BC for use in the full timing support profile should be capable of tolerating the following levels of dTE and phase wander simultaneously:

- dTE according to [ITU-T G.8271.1] network limit, clause 7.3 at the PTP input;
- wander tolerance according to [ITU-T G.8262], clause 9.1 at the SyncE input;
- wander tolerance according to [ITU-T G.813], clause 8.1 at the SDH input.

NOTE 2 – The noise tolerance for high frequency noise is for further study.

7.3 Noise transfer

The transfer characteristic of the T-BC determines its properties with regard to the transfer of time error from the PTP input interface to the PTP and 1 PPS output interfaces. It also accounts for the transfer of phase wander from the physical layer interface to the PTP and 1 PPS output interfaces.

NOTE 1 – For purposes of measuring the noise transfer, the impact of the test method may be critical. For example, it is known that some signal artefacts (known as sub-Nyquist artefacts) may be present due to improper test frequency selection. In particular, when using direct measurement methods or when measuring the noise transfer of a nonlinear filter, test signal frequencies that are equal to (m/n) multiplied by the Nyquist frequency, where (m/n) is a reduced fraction and m and n are small integers (e.g., less than 10) should be avoided. For instance, for a Nyquist frequency of 0.5Hz, examples of frequencies that should be avoided are 0.1 Hz ($m=1, n=5$), 0.25 Hz ($m=1, n=2$), 0.3 Hz ($m=3, n=5$), 0.5 Hz ($m=1, n=1$), 0.7 Hz ($m=7, n=5$), 1Hz ($m=2, n=1$), 2Hz ($m=4, n=1$), etc. and frequencies very close to these frequencies. Other mathematical processing methods may be less restricted with the choice of frequencies used. However, frequencies of the type $(m,1)$ should be avoided as they cannot be measured. Details on specific methods are for further study.

NOTE 2 – At all permissible noise input levels, the gain peaking from PTP to PTP, or from physical layer frequency to PTP is far lower than the permitted noise generation of the clock at the PTP and 1 PPS outputs. Therefore it may be difficult to verify the gain peaking at either the PTP or 1 PPS outputs.

7.3.1 PTP to PTP and PTP to 1 PPS noise transfer

The bandwidth of a T-BC should not exceed 0.1 Hz and should not be less than 0.05 Hz.

In the passband, the phase gain of the T-BC should be smaller than 0.1 dB.

NOTE 1 – Noise transfer only applies to dynamic time noise; there is no requirement related to cTE transfer.

NOTE 2 – See Note 1 and Note 2 in clause 7.3.

NOTE 3 – Since the PTP message rate is nominally 16Hz, the maximum observable input frequency content would be 8Hz.

NOTE 4 – When measuring on the 1 PPS output, the response to an input frequency component above 0.5Hz will be measured as an aliased component.

7.3.2 Physical layer frequency to PTP and physical layer frequency to 1 PPS noise transfer

The output PTP signal and 1PPS signal must correspond to the input physical layer frequency input signal on which a band-pass filter whose lower corner frequency is between 0.05 Hz and 0.1 Hz and whose upper corner frequency is between 1 Hz and 10 Hz has been applied.

In the passband, the phase gain of the EEC should be smaller than 0.2 dB (2.3%).

NOTE 1 – The above requirement applies to the case where a physical layer clock is implemented as per [ITU-T G.8262] option 1 to assist the T-BC, where the filter bandwidth is between 1 Hz and 10 Hz. When a different physical layer clock is used with a lower filter bandwidth to assist the T-BC, such as [ITU-T G.812] Type I, the input physical layer frequency noise transferred to the output PTP (1 PPS) signal is further attenuated. The detailed characteristics of the T-BC based on clocks different from [ITU-T G.8262] Option 1 is for further study, such as the impact on Annex B (control of transients due to rearrangements in the SyncE network) and noise accumulation in a chain of T-BC.

NOTE 2 – See Note 1 and Note 2 in clause 7.3.

NOTE 3 – When measuring on the PTP output, the response to an input frequency component above 8 Hz will be measured as an aliased component.

NOTE 4 – When measuring on the 1 PPS output, the response to an input frequency component above 0.5 Hz will be measured as an aliased component.

7.4 Transient response and holdover performance

7.4.1 Transient response

7.4.1.1 PTP to PTP and PTP to 1PPS transient response

The PTP to PTP transient response requirements applicable to a T-BC are for further study.

7.4.1.2 Physical layer frequency to PTP and physical layer frequency to 1PPS transient response

The physical layer frequency to PTP transient response due to a rearrangement of the physical layer frequency transport is specified in Annex B.

The response to an interruption or degradation of the physical layer frequency input for a period longer than specified in Annex B, where the T-BC operates only using the PTP input, is for further study.

7.4.2 Holdover performance

When a T-BC loses all of its input phase and time references, it enters the phase/time holdover state. Under these circumstances, the T-BC may either rely on the holdover of a local oscillator, or on a physical layer frequency assistance reference traceable to a primary reference clock (PRC), or on a combination of both.

This requirement reflects the performance of the clock in cases when the PTP input is ideal followed by disconnection of the PTP input. For the case of phase/time holdover requirements based on physical layer frequency (T-BC performance with physical layer frequency assistance during loss of PTP input reference), the frequency physical layer input is ideal.

This requirement bounds the maximum excursions in the PTP and 1PPS output signal. Additionally, it restricts the accumulation of the phase movement during input signal impairments or internal disturbances.

7.4.2.1 T-BC holdover

The phase/time holdover (both physical layer and PTP inputs are lost) requirements applicable to a T-BC are for further study.

7.4.2.2 T-BC performance with physical layer frequency assistance during loss of PTP input reference

The phase/time output will be measured through a first order low-pass filter with bandwidth of 0.1 Hz.

The phase/time performance during loss of PTP input reference requirements based on physical layer frequency applicable to a T-BC under constant temperature conditions is shown in Table 7-6 and Figure 7-1. Under constant temperature conditions (within $\pm 1\text{K}$) the maximum observation interval is 1 000 seconds.

Table 7-6 – Performance allowance during loss of PTP input (MTIE) for T-BC with constant temperature

MTIE limit [ns]	Observation interval τ [s]
$22 + 40 \tau^{0.1}$	$1 \leq \tau \leq 100$
$22 + 25.25 \tau^{0.2}$	$100 < \tau \leq 1\ 000$

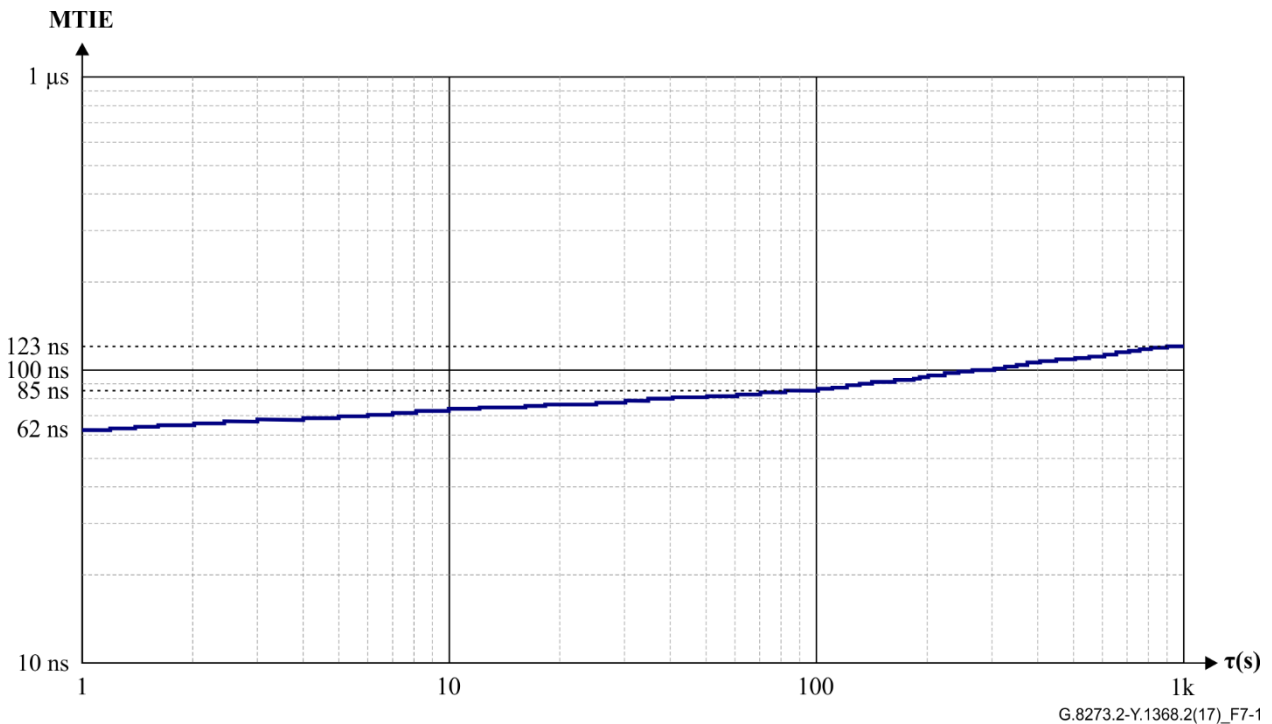

Figure 7-1 – Performance allowance during loss of PTP input (MTIE) for T-BC with constant temperature

The phase/time performance during loss of PTP input reference requirements based on physical layer frequency applicable to a T-BC under variable temperature conditions is shown in Table 7-7 and Figure 7-2. Under variable temperature conditions the maximum observation interval is 10 000 seconds.

Table 7-7 – Performance allowance during loss of packet signal input (MTIE) for T-BC with variable temperature

MTIE limit [ns]	Observation interval τ [s]
$22 + 40 \tau^{0.1} + 0.5 \tau$	$1 \leq \tau \leq 100$
$72 + 25.25 \tau^{0.2}$	$100 < \tau \leq 1\ 000$
for further study	$1\ 000 < \tau \leq 10\ 000$

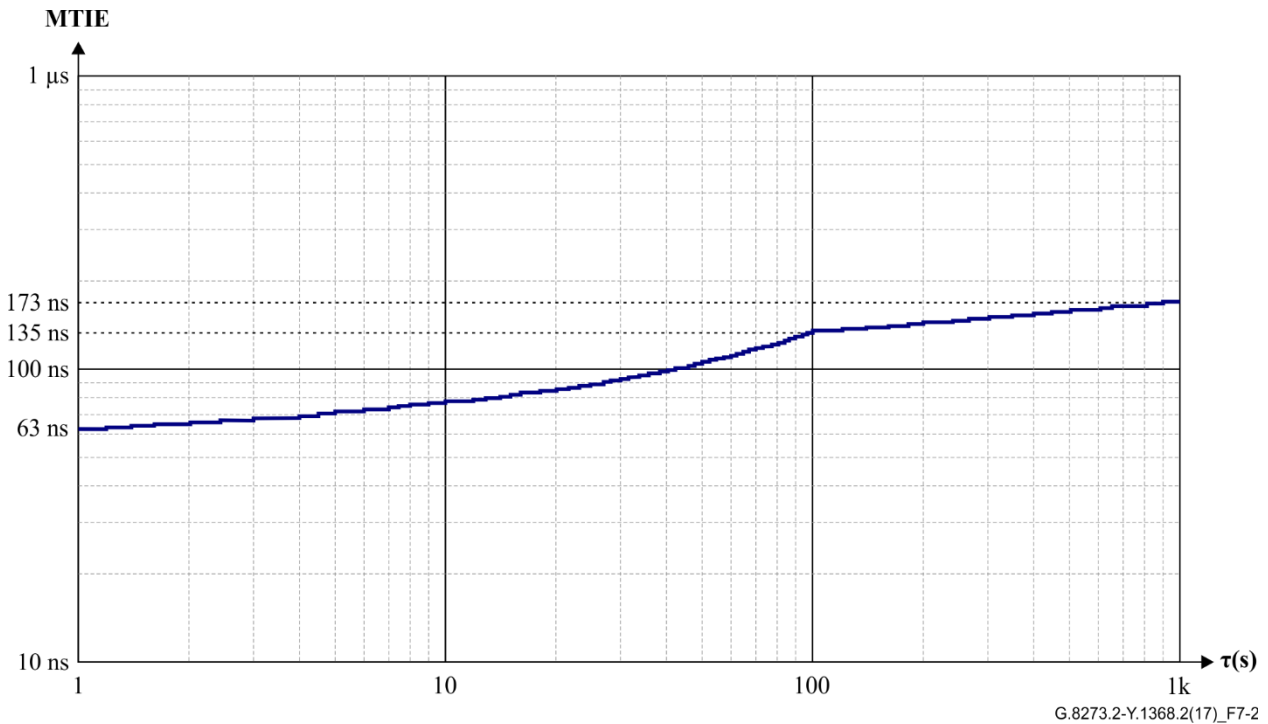

Figure 7-2 – Performance allowance during loss of PTP input (MTIE) for T-BC with variable temperature

NOTE – Guidelines for variable temperature testing are described in Appendix I of [ITU-T G.8273].

7.5 Interfaces

The requirements in this Recommendation are related to reference points which may be internal to the equipment or network element (NE) in which the T-BC is embedded and are therefore not necessarily available for measurement or analysis by the user. Consequently, the performance of the T-BC is not specified at these internal reference points, but rather at the external interfaces of the equipment.

Note that not all of the interfaces below need to be implemented on all equipment.

7.5.1 Phase and time interfaces

The phase and time interfaces specified for the equipment in which the T-BC may be contained are:

- Ethernet interface carrying PTP messages;
NOTE – Ethernet interfaces can combine synchronous Ethernet for frequency and PTP messages.
- ITU-T V.11-based time/phase distribution interface, as defined in [ITU-T G.703] and [ITU-T G.8271];
- 1 PPS 50 Ω phase-synchronization measurement interface, as defined in [ITU-T G.703] and [ITU-T G.8271];

- other interfaces are for further study.

7.5.2 Frequency interfaces

The frequency interfaces specified for the equipment in which the T-BC may be contained are:

- 2 048 kHz interfaces according to [ITU-T G.703] with additional jitter and wander requirements as specified herein;
- 1 544 kbit/s interfaces according to [ITU-T G.703] with additional jitter and wander requirements as specified herein;
- 2 048 kbit/s interfaces according to [ITU-T G.703] with additional jitter and wander requirements as specified herein;
- STM-N traffic interfaces;
- synchronous Ethernet interfaces;
(NOTE – Ethernet interfaces can combine PTP and synchronous Ethernet.)
- other interfaces are for further study.

Annex A

Telecom boundary clock model

(This annex forms an integral part of this Recommendation.)

Figure A.1 illustrates a telecom boundary clock model.

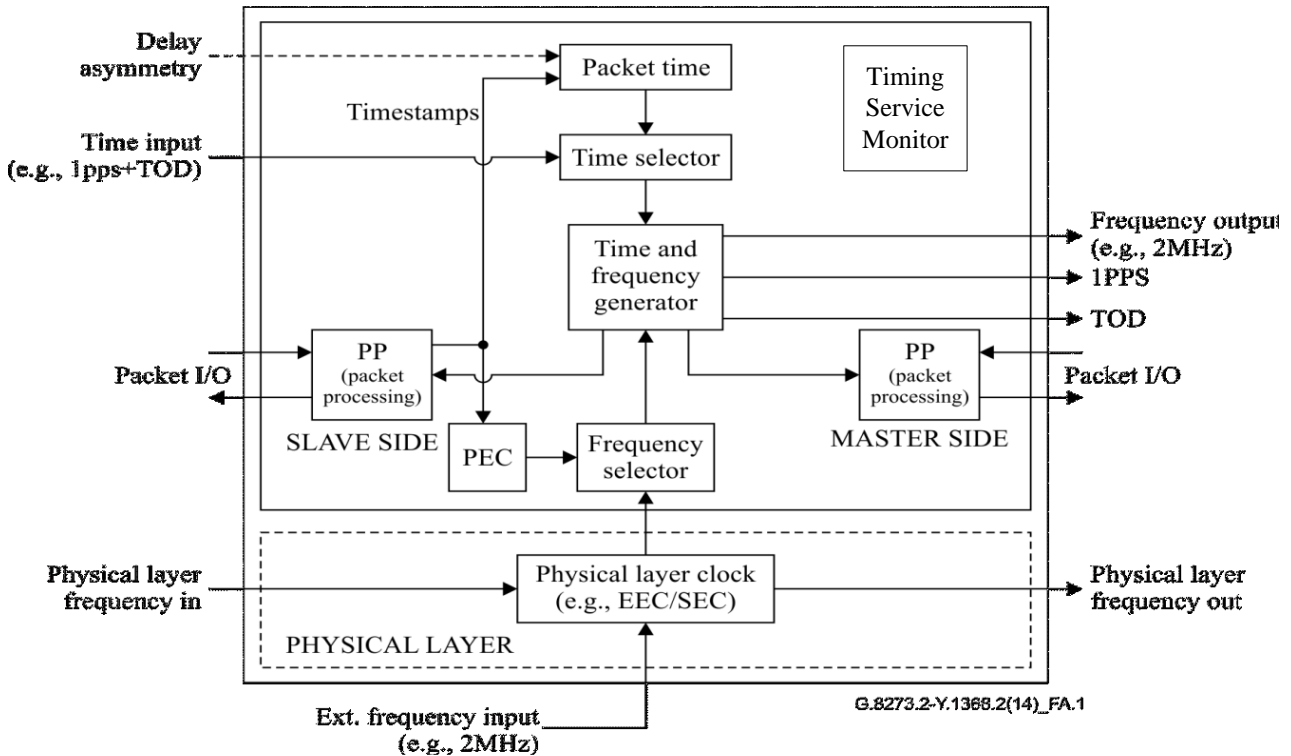

NOTE 1 – The physical layer frequency signal may be bidirectional for SyncE/SDH.

NOTE 2 – The "Physical layer clock" includes a selection mechanism as there may be multiple inputs.

NOTE 3 – T-BC functional model is also applicable to the T-TSC, except for the PTP master side (the T-TSC functional model includes the 1 PPS and ToD interface).

Figure A.1 – Boundary clock model

Figure A.1 shows a functional model of a telecom boundary clock. It is not intended to specify any specific implementation. Any implementation specific detail is outside the scope of this Recommendation.

The packet timing signal is processed by the packet processing block, the timestamps are sent to the packet time and to the packet-based equipment clock (PEC) blocks for further processing. The time information carried in the timestamps are used as an input to the time control to generate the time information to control the local time scales. Delay asymmetry established by means beyond the scope of the protocol-layer messages can be provided as a correction term. The frequency information carried in the timestamps is used in the PEC to generate the local frequency.

The time selector block may select either the time information recovered from the timestamps, or the local time input (e.g., 1 PPS+ time of day (ToD)).

The frequency selector block may select either the frequency information recovered from the timestamps, or the frequency recovered from a physical layer clock (e.g., synchronous Ethernet, or SDH).

The timing service monitor block provides monitoring of a timing service received by the clock according to key performance indicators. As an example, it may monitor the PTP timing service by analysing the PTP timestamps from the packet processing block (slave side) and raise an unusable alarm based on implementation specific criteria.

Annex B

Control of the phase transient due to rearrangements in the synchronous Ethernet network

(This annex forms an integral part of this Recommendation.)

A T-BC and T-TSC shall properly limit the generation of phase/time error due to a rearrangement of the physical layer frequency transport (e.g., SyncE, SDH) by using ingress QL information (e.g., ESMC message). In the worst-case, the input SyncE/SDH frequency will experience a re-arrangement transient as detailed in Figure 12 of [ITU-T G.8262] and Figure 12 of [ITU-T G.813]. When a SyncE/SDH rearrangement occurs, the T-BC or T-TSC may experience an initial output transient when the SyncE/SDH loses PRC-traceability and a second output transient when or after the SyncE/SDH again becomes PRC-traceable. The absolute value of T-BC and T-TSC output phase error shall meet the following requirements when these transients occur:

- a) The T-BC output phase error at the PTP and 1 PPS outputs and the T-TSC output phase error at the 1 PPS output shall not exceed the mask of Figure B.1 and Table B.1 below.

NOTE – The mask of Figure B.1 assumes that the SyncE/SDH signal loses PRC traceability at time zero and becomes traceable again at 15 s (i.e., the SyncE/SDH transient is completed by 15 s). The re-establishment of PRC-traceability will be earlier in smaller rings; the exact time depends on the number of EECs/SECs in the ring and the exact values of the SSM message delays. The mask is extended to 50 s to allow time for the T-BC and the T-TSC to either re-acquire the SyncE/SDH signal or begin using the T-BC and the T-TSC filter again after PRC-traceability has been re-established.

The SyncE/SDH transient test is done without a measurement filter and should exclude any constant time error. Ideally, the absolute value of unfiltered dTE is desired.

See Appendix II for background on the assumptions and derivations for the masks of Figure B.1 and Table B.1.

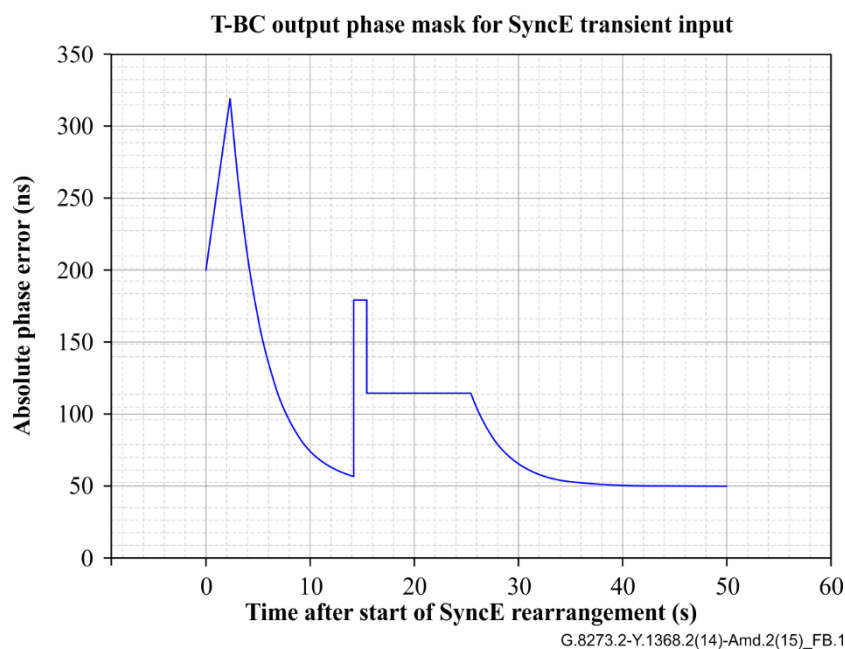

Figure B.1 – Phase error limit for output phase error transient after the start of the SyncE/SDH rearrangement

Table B.1 – T-BC and the T-TSC output phase transient mask for output transient after start of SyncE/SDH rearrangement (at and just after loss of PRC-traceability by the SyncE/SDH signal)

Time S after start of SyncE/SDH rearrangement (s)	T-BC and the T-TSC output absolute phase error (ns)
$0 \leq S < 2.4$	$200 + 50S$
$2.4 \leq S < 14.25$	$50 + 270 e^{-2\pi(0.05)(S - 2.4)}$
$14.25 \leq S < 15.5$	180
$15.5 \leq S < 25.5$	115
$25.5 \leq S \leq 50$	$50 + 65 e^{-2\pi(0.05)(S - 25.5)}$

NOTE – As per [ITU-T G.8264] SSM might be disabled by the operator. The impact on the mitigation of time error due to SyncE/SDH rearrangement when not using SSM is under the responsibility of the operator and is for further study.

Annex C

Telecom time slave clock requirements

(This annex forms an integral part of this Recommendation.)

C.1 Physical layer frequency performance requirements

The list of the applicable physical layer frequency interfaces is provided in clause C.2.5.2.

The following applies for the synchronous Ethernet and SDH interfaces:

Synchronous Ethernet interfaces and EECs used in the telecom time slave clock (T-TSC) shall meet the performance requirements specified in [ITU-T G.8262] and shall generate and process ESMC messages as specified in [ITU-T G.8264].

SDH interfaces and SECs used in the T-TSC shall meet the performance requirements specified in [ITU-T G.813], and shall generate and process SSM messages as specified in [ITU-T G.781].

NOTE – The ITU-T G.8273.2 T-TSC model does not exclude the use of other physical layer clocks (e.g., [ITU-T G.812] Type I) within the equipment related to the operation between the physical layer input to physical layer output interface behaviour, in accordance to the existing [ITU-T G.803] reference chain and [ITU-T G.8261] network limits.

C.2 T-TSC packet layer performance requirements for full timing support from the network

C.2.1 Constant time error and dynamic time error noise generation

The noise generation of a T-TSC represents the amount of noise produced at the output of the T-TSC when there is an ideal input reference packet timing signal.

Under normal, locked operating conditions, the time output of the T-TSC should be accurate to within the maximum absolute time error ($\max|TE|$). This value includes all the noise components, i.e., the cTE and the dTE noise generation.

In order to support different performance requirements at the end application specified in Table 1 of [ITU-T G.8271] using different network topologies and network technologies, the maximum absolute time error, the constant time error and the dTE noise generation requirements for T-TSCs are divided into two classes: Class A and Class B.

At the 1 PPS output, the maximum absolute time error ($\max|TE|$) for Class A and Class B is shown in Table C.1. This includes all time error and components (unfiltered).

Table C.1 – Maximum absolute time error ($\max|TE|$)

T-TSC Class	Maximum absolute time error – $\max TE $ (ns)
A	100 ns
B	70 ns

The noise generation is divided into two components, the cTE and the dTE noise generation.

C.2.1.1 Constant time error generation

At the 1 PPS output, the cTE generation for Class A and Class B is shown in Table C.2.

Table C.2 – T-TSC permissible range of constant time error

T-TSC Class	Permissible range of constant time error – cTE(ns)
A	±50
B	±20

NOTE – Constant time error definition and the method to estimate constant time error are defined in [ITU-T G.8260]. For the purpose of testing the limits in Table C.2, an estimate of constant time error should be obtained by averaging the time error sequence over 1 000 s.

C.2.1.2 Dynamic time error low-pass filtered noise generation (dT_{EL})

For a T-TSC Class A or Class B containing an EEC-Option 1 clock, and operating in the locked mode synchronized to both a wander-free time reference at the PTP input and a wander-free frequency reference at the physical layer frequency input, the MTIE at the 1 PPS output, measured through a first order low-pass filter with bandwidth of 0.1 Hz, should meet the limits in Table C.3 under constant temperature (within ±1 K).

Table C.3 – Dynamic time error low-pass filtered noise generation (MTIE) for T-TSC with constant temperature

MTIE limit [ns]	Observation interval τ [s]
40	$1 < \tau \leq 1\ 000$

When temperature effects are included, the MTIE requirement is defined in Table C.4 for a T-TSC with physical layer frequency support; in this case the maximum observation interval is increased to 10 000 s.

Table C.4 – Dynamic time error low-pass filtered noise generation (MTIE) for T-TSC with variable temperature

MTIE limit [ns]	Observation interval τ [s]
40	$1 < \tau \leq 10\ 000$

NOTE – Guidelines for variable temperature testing are described in Appendix I of [ITU-T G.8273].

For a Class A or Class B T-TSC containing an EEC-Option 1 clock, and operating in locked mode synchronized to both a wander-free time reference at the PTP input and a wander-free frequency reference at the physical layer frequency input, the TDEV at the 1 PPS output, measured through a first-order low-pass filter with bandwidth of 0.1 Hz, should meet the limits in Table C.5 under constant temperature (within ±1K).

Table C.5 – Dynamic time error low-pass filtered noise generation (TDEV) for T-TSC with constant temperature

TDEV limit [ns]	Observation interval τ [s]
4	$1 < \tau \leq 1\ 000$

C.2.1.3 Dynamic time error high-pass filtered noise generation (dTE_H)

For a T-TSC containing an EEC-Option 1 clock, and operating in a locked mode synchronized to both a noise-free time reference at the PTP input and a noise-free frequency reference at the physical layer frequency input, the peak-to-peak time error at the T-TSC output interfaces, measured over a 1 000 second measurement interval, with a first-order high-pass filter of 0.1 Hz must be less than 70 ns.

NOTE 1 – The value of 70 ns is a conservative limit based on the SEC/EEC noise generation specification. This is based on the assumption that most of this noise is generated by the high-pass filtered noise of the SEC/EEC oscillator. It is expected that implementations based on better clocks can result in significantly lower values. It is not intended and not assumed that the component of the high-pass filtered noise due to timestamp granularity is a major portion of the 70 ns.

NOTE 2 – The noise tolerance for high frequency noise is for further study.

C.2.2 Noise tolerance

The noise tolerance of a T-TSC indicates the minimum dynamic time error level at the input of the clock that should be accommodated while:

- not causing any alarms;
- not causing the clock to switch reference;
- not causing the clock to go into holdover.

NOTE – There is no requirement related to cTE tolerance.

A T-TSC for use in the full timing support profile should be capable of tolerating the following levels of dTE and phase wander simultaneously:

- dTE according to [ITU-T G.8271.1] network limit, clause 7.3 at the PTP input;
- wander tolerance according to [ITU-T G.8262], clause 9.1 at the SyncE input;
- wander tolerance according to [ITU-T G.813], clause 8.1 at the SDH input.

C.2.3 Noise transfer

The transfer characteristic of the T-TSC determines its properties with regard to the transfer of time error from the PTP input interface to the 1 PPS output interface. It also accounts for the transfer of phase wander from the physical layer interface to the 1 PPS output interface.

NOTE1– For purposes of measuring the noise transfer, the impact of the test method may be critical. For example, it is known that some signal artefacts (known as sub-Nyquist artefacts) may be present due to improper test frequency selection. In particular, when using direct measurement methods or when measuring the noise transfer of a nonlinear filter, test signal frequencies that are equal to (m/n) multiplied by the Nyquist frequency, where (m/n) is a reduced fraction and m and n are small integers (e.g., less than 10) should be avoided. For instance, for a Nyquist frequency of 0.5Hz, examples of frequencies that should be avoided are 0.1 Hz ($m=1, n=5$), 0.25 Hz ($m=1, n=2$), 0.3 Hz ($m=3, n=5$), 0.5 Hz ($m=1, n=1$), 0.7 Hz ($m=7, n=5$), 1Hz ($m=2, n=1$), 2Hz ($m=4, n=1$), etc. and frequencies very close to these frequencies. Other mathematical processing methods may be less restricted with the choice of frequencies used. However, frequencies of the type $(m,1)$ should be avoided as they cannot be measured. Details on specific methods are for further study..

NOTE 2 – At all permissible noise input levels, the gain peaking from PTP to 1 PPS, or from physical layer frequency to 1 PPS is far lower than the permitted noise generation of the clock at the 1 PPS output. Therefore it may be difficult to verify the gain peaking at the 1 PPS output.

C.2.3.1 PTP to 1 PPS noise transfer

The bandwidth of a T-TSC should not exceed 0.1 Hz and should not be less than 0.05 Hz.

In the passband, the phase gain of the T-TSC should be smaller than 0.1 dB.

NOTE 1 – Noise transfer only applies to dynamic time error noise; there is no requirement related to cTE transfer.

NOTE 2 – See Note 1 and Note 2 in clause C.2.3.

NOTE 3 – Since the PTP message rate is nominally 16Hz, the maximum observable input frequency content would be 8Hz.

NOTE 4 – When measuring on the 1 PPS output, the response to an input frequency component above 0.5Hz will be measured as an aliased component.

C.2.3.2 Physical layer frequency to 1 PPS noise transfer

The output 1 PPS signal must correspond to the input physical layer frequency input signal on which a band-pass filter whose lower corner frequency is between 0.05 Hz and 0.1 Hz, and whose upper corner frequency is between 1 Hz and 10 Hz has been applied.

In the passband, the phase gain of the EEC should be smaller than 0.2 dB (2.3%).

NOTE 1 – The above requirement applies to the case where a physical layer clock is implemented as per [ITU-T G.8262] option 1 to assist the T-TSC, where the physical layer clock bandwidth is between 1 Hz and 10 Hz. When a different physical layer clock, with a lower filter bandwidth and based on one of the clock types allowed for use in the physical layer frequency synchronization chain (e.g., [ITU-T G.812] Type I), is used to assist the T-TSC, it provides greater attenuation of the input physical layer frequency signal noise transferred to the output 1 PPS signal. The actual behaviour depends on the characteristics of the physical layer clock that is used. As an example, with [ITU-T G.812] Type I, where the bandwidth is 3 mHz or less, the lower filter bandwidth results in a greatly reduced physical layer signal noise transferred to the output 1 PPS signal as compared to the case of the [ITU-T G.8262] option 1 clock.

NOTE 2 – See Note 1 and Note 2 in clause C.2.3.

NOTE 3 – When measuring on the 1 PPS output, the response to an input frequency component above 0.5Hz will be measured as an aliased component.

C.2.4 Transient response and holdover performance

C.2.4.1 Physical layer frequency to 1 PPS transient response

The physical layer frequency to 1 PPS transient response due to a rearrangement of the physical layer frequency transport is specified in Annex B of this Recommendation.

Note – Annex B has been developed based on the assumption of a physical layer clock implemented as per [ITU-T G.8262] option 1 to assist the T-TSC, where the physical layer clock bandwidth is between 1 Hz and 10 Hz. When a different physical layer clock, with a lower filter bandwidth and based on one of the clock types allowed for use in the physical layer frequency synchronization chain (e.g., [ITU-T G.812] Type I), is used to assist the T-TSC, it provides greater attenuation of the input physical layer frequency signal noise transferred to the output 1 PPS signal. Therefore, the T-TSC will keep the output transients below the phase error transient response mask specified in Annex B.

C.2.4.2 Holdover performance

When a T-TSC loses all its input phase and time references, it enters the phase/time holdover state. Under these circumstances, the T-TSC may either rely on the holdover of a local oscillator, or on a physical layer frequency assistance reference traceable to a PRC, or on a combination of both.

This requirement reflects the performance of the clock in cases when the PTP input is ideal followed by disconnection of the PTP input. For the case of phase/time holdover requirements based on physical layer frequency (T-TSC performance with physical layer frequency assistance during loss of PTP input reference), the frequency physical layer input is ideal.

This requirement bounds the maximum excursions in the output timing signal. Additionally, it restricts the accumulation of the phase movement during input signal impairments or internal disturbances.

C.2.4.2.1 T-TSC holdover

The time holdover (when both physical layer and PTP inputs are lost) requirements applicable to a T-TSC are for further study.

C.2.4.2.2 T-TSC performance with physical layer frequency assistance during loss of PTP Input Reference

The phase/time output will be measured through a first order low-pass filter with bandwidth of 0.1 Hz.

The phase/time performance during loss of PTP input reference requirements based on physical layer frequency applicable to a T-TSC under constant temperature conditions is shown in Table C.6 and Figure C.1. Under constant temperature conditions (within $\pm 1\text{K}$) the maximum observation interval is 1 000 seconds.

Table C.6 – Performance allowance during loss of PTP input (MTIE) for T-TSC with constant temperature

MTIE limit [ns]	Observation interval τ [s]
$22 + 40 \tau^{0.1}$	$1 \leq \tau \leq 100$
$22 + 25.25 \tau^{0.2}$	$100 < \tau \leq 1\ 000$

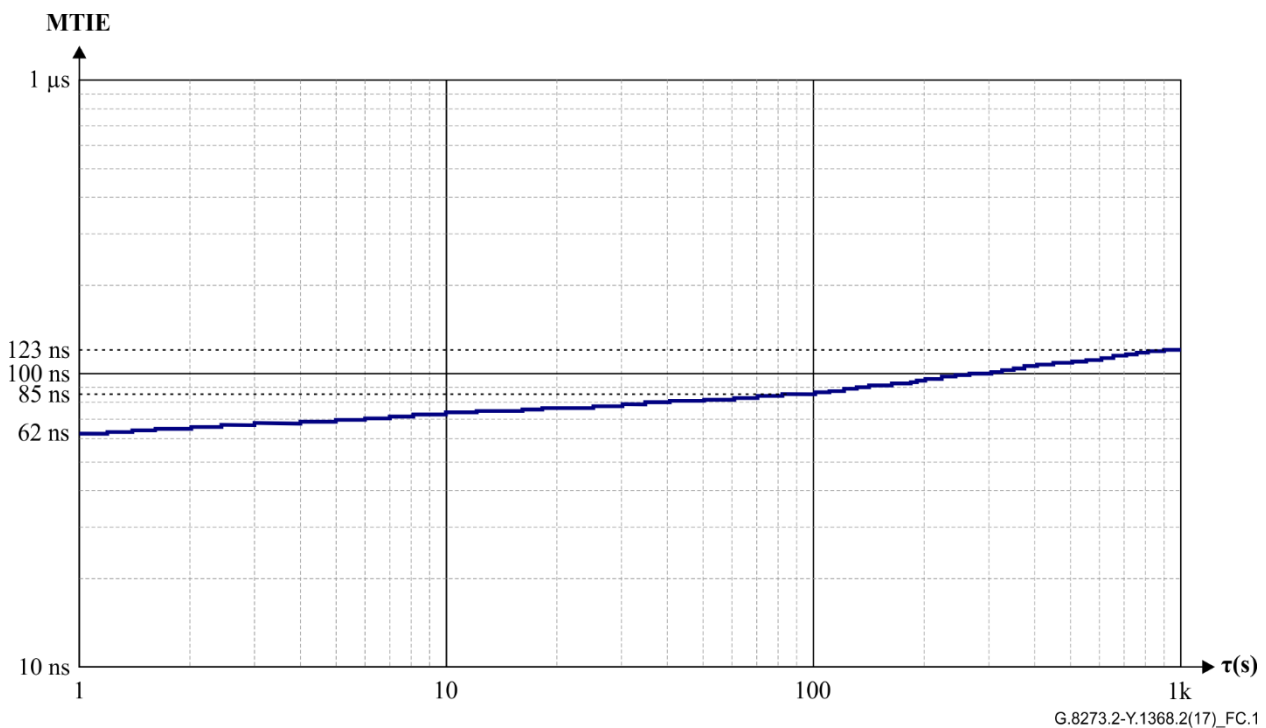
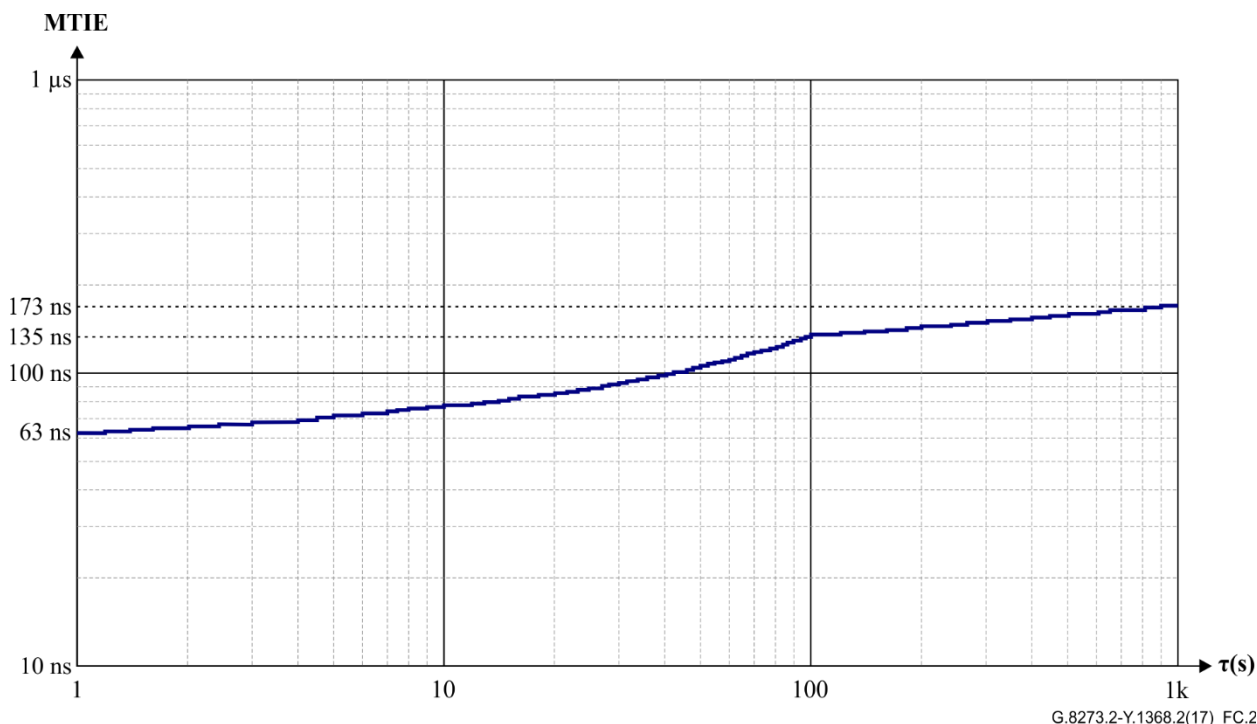

Figure C.1 – Performance allowance during loss of PTP input (MTIE) for T-TSC with constant temperature

The phase/time performance during loss of PTP input reference requirements based on physical layer frequency applicable to a T-TSC under variable temperature conditions is shown in Table C.7 and Figure C.2. Under variable temperature conditions the maximum observation interval is 10 000 seconds.

**Table C.7 – Performance allowance during loss of PTP input (MTIE)
for T-TSC with variable temperature**

MTIE limit [ns]	Observation interval τ [s]
$22 + 40 \tau^{0.1} + 0.5 \tau$	$1 \leq \tau \leq 100$
$72 + 25.25 \tau^{0.2}$	$100 < \tau \leq 1\ 000$
for further study	$1\ 000 < \tau \leq 10\ 000$



**Figure C.2 – Performance allowance during loss of PTP input (MTIE)
for T-TSC with variable temperature**

NOTE – Guidelines for variable temperature testing are described in Appendix I of [ITU-T G.8273].

C.2.5 Interfaces

The requirements in this Recommendation are related to reference points which may be internal to the equipment or NE in which the T-TSC is embedded and are therefore not necessarily available for measurement or analysis by the user. Consequently, the performance of the T-TSC is not specified at these internal reference points, but rather at the external interfaces of the equipment.

Note that not all of the interfaces below need to be implemented on all equipment.

C.2.5.1 Phase and time interfaces

The phase and time interfaces specified for the equipment in which the T-TSC may be contained are:

- Ethernet interface carrying PTP messages;
NOTE – Ethernet interfaces can combine Synchronous Ethernet for frequency and PTP messages.
- ITU-T V.11-based time/phase distribution interface, as defined in [ITU-T G.703] and [ITU-T G.8271];
- 1 PPS 50 Ω phase-synchronization measurement interface, as defined in [ITU-T G.703] and [ITU-T G.8271];
- other interfaces are for further study.

C.2.5.2 Frequency interfaces

The frequency interfaces specified for the equipment in which the T-TSC may be contained are:

- 2 048 kHz interfaces according to [ITU-T G.703] with additional jitter and wander requirements as specified herein;
- 1 544 kbit/s interfaces according to [ITU-T G.703] with additional jitter and wander requirements as specified herein;
- 2 048 kbit/s interfaces according to [ITU-T G.703] with additional jitter and wander requirements as specified herein;
- STM-N traffic interfaces;
- synchronous Ethernet interfaces;
- other interfaces are for further study.

C.2.6 T-TSC performance measurement

It is necessary to provide means for measuring the T-TSC performance (including when deployed in the field).

The use of 1 PPS 50 Ω phase-synchronization measurement output physical interface is the recommended way to perform performance measurement and analysis of the T-TSC (see [ITU-T G.703]). When time of day information is to be tested other interfaces should be considered (e.g., 1 PPS V.11 interface, see [ITU-T G.703]).

NOTE 1 – For cases when provisioning of dedicated testing interface is not feasible (e.g., due to equipment dimension such as equipment related to small cell environments), other means should be provided. This is for further study.

NOTE 2 – It may be beneficial to also measure the performance at the output of the end application (e.g., in the case of radio base stations at the radio interface output), the definition of the related methods are under responsibility of the relevant standardization body.

Appendix I

Mitigation of time error due to SyncE/SDH transients

(This appendix does not form an integral part of this Recommendation.)

Appendix II, clause II.1.2 of [ITU-T G.8271.1], illustrates hypothetical reference models for the transport of phase/time via PTP with physical layer frequency support. Figure II.2 of [ITU-T G.8271.1] illustrates the congruent scenario, where the frequency and phase/time transports follow the same synchronization path. Figure II.3 of [ITU-T G.8271.1] illustrates the non-congruent scenario, where the frequency and phase/time transports follow different synchronization paths. A rearrangement of the physical layer frequency, e.g., SyncE, transport results in phase/time error at each T-BC, the T-TSC and the end application.

In the congruent scenario, the time error due to the SyncE/SDH rearrangement can be reduced to an acceptable level if the physical layer signal is rejected after the physical layer transient is detected. Note that the rejection of the physical layer signal is an implementation method. This method permits switching temporarily, for a short period, upon detection of a SyncE/SDH failure (e.g., using the SSM information), from a mode where SyncE/SDH support is used for frequency transport to a mode where only the PTP messages are used to recover frequency; after the SyncE/SDH reconfiguration is completed, the mode of operation is still expected to become again based on SyncE/SDH for frequency transport. Specifically, the SyncE/SDH signal is rejected when the SSM indicating the SyncE/SDH signal is no longer PRC-traceable is received by the EEC collocated with that T-BC and the SyncE/SDH signal is again used at a time T_{reacq} after receipt of the SSM indicating the SyncE signal is again PRC-traceable is received by the EEC/SEC collocated with that T-BC.

In the non-congruent scenario, the time error will be acceptable if the T-BCs, T-TSC and end application have maximum bandwidth of 0.1 Hz and maximum gain peaking of 0.1 dB, and if the frequency plane clocks collocated with the T-BCs, T-TSC and end application are EECs/SECs. This is true whether or not the SyncE/SDH transient is rejected at each T-BC.

Appendix II

Derivation of T-BC output transient mask due to SyncE/SDH rearrangement

(This appendix does not form an integral part of this Recommendation.)

The absolute value of T-BC output phase transient due to a SyncE/SDH rearrangement is derived for the following two mitigation schemes:

- a) Reject the SyncE/SDH signal on receipt of the SSM that indicates the SyncE/SDH is no longer PRC-traceable, and
- b) Turn off the T-BC filter on receipt of the SSM that indicates the SyncE/SDH is no longer PRC-traceable

In the derivation, the input transient is assumed to be as specified in Figure 12 of [ITU-T G.8262], with the initial 120 ns phase change starting at time zero and the final 120 ns phase change ending 15 s later. The output transients for schemes (a) and (b) are obtained and the transient mask is taken as the upper envelope of these two output transients.

II.1 Background on assumptions for and derivation of T-BC output phase error due to a SyncE/SDH rearrangement

The T-BC output phase error mask of Figure B.1 of Annex B of this Recommendation is based on two possible techniques for mitigating the output phase error due to the HRM2 rearrangement. With the first technique, the EEC co-located with the T-BC informs the T-BC that the SyncE/SDH is no longer PRC-traceable when the EEC receives the SSM indicating this. When the T-BC is notified, it rejects the SyncE/SDH transient and operates in the pure PTP mode (i.e., without the use of SyncE/SDH to recover frequency). When the EEC switches a second time and is again PRC-traceable, it informs the T-BC. The T-BC then reacquires the SyncE/SDH signal. The T-BC typically waits at least 10 s after it is informed that the SyncE/SDH is again traceable to reacquire the SyncE/SDH, to ensure that the SyncE/SDH transient is completed; however, the important condition is that the mask of Figure B.1 is satisfied (i.e., the T-BC can reacquire the SyncE/SDH signal before 10 s have elapsed if it can satisfy the mask).

With the second technique, the T-BC filter is turned off when the T-BC is notified by the EEC that the SyncE/SDH is no longer traceable (i.e., when the EEC receives the SSM indicating this). The turning off of the filter means that it is no longer applied to the incoming PTP signal (as a low-pass filter) or to the SyncE/SDH signal (as a high-pass filter). When the T-BC is notified by the EEC that the SyncE/SEC is again traceable, the filter is again turned on. As with the first technique, the T-BC typically waits at least 10 s after it is informed that the SyncE/SDH is again traceable to turn the filter on, to ensure that the SyncE/SDH transient is completed; however, the important condition is that the mask of Figure B.1 is satisfied (i.e., the T-BC can turn the filter back on before 10 s have elapsed if it can satisfy the mask). To avoid a transient when the T-BC filter is turned back on, the filter continues to operate on the SyncE/SDH signal (with the SyncE/SDH transient present) and the PTP signal and the state of the filter is computed throughout the transient (i.e., at each sampling instant). However, the filter output is not used while the filter is turned off; the computations are done only so that the filter state will be known. When the filter is turned back on, the computed filter state at that instant is used as the initial state.

The mask of Figure B.1 is obtained by computing the absolute value of T-BC filter output phase error history, for each of the above techniques, assuming the SyncE/SDH undergoes the transient of Figure 12 of [ITU-T G.8262]. With each technique, it is found that the T-BC filter output history contains an initial transient when SyncE/SDH traceability is lost and a second transient when or shortly after SyncE/SDH traceability is regained. The actual duration of the time interval between

the two transients depends on how large the EEC ring is (the interval is longer for larger rings). However, in Figure 12 of [ITU-T G.8262] the time interval between the start of the initial transient (i.e., the first 120 ns phase change at a rate of 7.5 ppm) and the start of the second transient (i.e., the second 120 ns phase change at a rate of 7.5 ppm) is 14.984 s.

The steady-state T-BC noise generation requirements are:

- 1) $\max|TE|$ limit of 100 ns for class A and 70 ns for class B (see Table 7-1 in clause 7.1).
- 2) cTE limit of ± 50 ns for class A and ± 20 ns for class B (see Table 7-2 in clause 7.1.1).
- 3) dTE MTIE limit of 40 ns, measured through a 0.1 Hz low-pass filter (see Table 7-3 in clause 7.1.2). This 40 ns includes the effect of EEC noise generation and timestamp granularity.
- 4) dTE high-frequency noise limit of 70 ns peak-to-peak, measured through a 0.1 Hz high-pass filter (see clause 7.1.3).

The SyncE/SDH transient test is done without a measurement filter and should exclude any constant time error. Ideally, the absolute value of unfiltered dTE is desired.

Simulations showed that the unfiltered dTE does not exceed 80 ns peak-to-peak. While selected results were not highly asymmetric, they did exhibit some asymmetry. To allow margin for some asymmetry, it will be assumed that the unfiltered dTE $\max|TE|$ is 50 ns. It is further assumed that the 50 ns maximum dTE is due to steady-state SyncE/SDH noise accumulation and timestamp granularity. Any phase error due to the SyncE/SDH rearrangement is added to this. Note that this value does not include the inherent random noise generation in the T-BC, as this has not yet been specified in ITU-T G.8273.2; once it is specified, it needs to be considered. In addition, this value does not include cTE. If it is not convenient to remove cTE, this must be added to the mask derived below, i.e., the total $\max|TE|$ from Table 1 (100 ns for class A and 70 ns for class B) must be used instead of the assumed 50 ns zero-to-peak for dTE.

In all cases, we assume the T-BC input is a PTP packet timing signal with mean Sync message rate of 16 messages/s. If other assumptions were made, e.g., if the input timing signal were 1 PPS instead of PTP, or if packet selection were performed that caused the mean rate of selected Sync message to be less than 16 messages/s, these cases would need to be analysed. In addition, the T-BC output phase computed is the actual phase (time) error; there is no additional measurement filter.

Note that in Figure III.2 of [ITU-T G.8273], which gives the input SyncE/SDH transient used in testing, the 120 ns phase changes and 50 ns/s phase rate of change are reduced to 104 ns and 45 ns/s respectively. This was done to allow some margin in the test. The mask is derived here using the input transient of Figure 12 of [ITU-T G.8262].

In addition, Appendix III of [ITU-T G.8273] presents three test methods. In the analysis here, we make conservative assumptions to produce a single mask that is applicable to all three methods. In particular, the input transient of Figure 12 of [ITU-T G.8262] is assumed to be the transient output of the EEC/SEC, which is input to the T-BC (but subject to the assumptions of the two schemes). This is subject to the assumptions that (a) in Method I of Appendix III of [ITU-T G.8273] the filtering of the EEC/SEC can be neglected and (b) in Method II of Appendix III of [ITU-T G.8273] the output of the EEC/SEC does not exceed the mask of Figure 12 of [ITU-T G.8262] when the SyncE/SDH signal input to interface Y (Figure III.1 of [ITU-T G.8273]) is cut off. Method III of Appendix III of [ITU-T G.8273] is less stringent, because in this method the ESMC QL is changed but no SyncE/SDH transient is applied.

The following are the assumptions made in computing the T-BC output phase error due to the SyncE/SDH rearrangement, using the first technique, i.e., rejection of the SyncE/SDH transient:

- a) The input transient to the T-BC at interface Y of Figure III of [ITU-T G.8273] is given by Figure 12 of [ITU-T G.8262].

- b) The input PTP packet signal (i.e., carried by Sync and Delay_Req messages) is perfect, i.e., there is no phase error associated with this signal.
- c) The T-BC filter bandwidth is 0.05 Hz. This is the minimum T-BC and T-TSC bandwidth. It is modelled as a first-order filter and gain peaking is not modeled.
- d) The EEC co-located with the T-BC receives an input SSM, indicating the SyncE/SDH signal is no longer PRC-traceable. This occurs 500-2 000 ms after the transient begins and represents the holdover message delay, i.e., T_{HM} . clause 5.14 of [ITU-T G.781] specifies that T_{HM} is in this range.
- e) The EEC co-located with the T-BC sends to the T-BC, via interface Z of Figure III.1 of [ITU-T G.8273], an SSM indicating it is no longer PRC-traceable between 0 and 200 ms after it receives the changed SSM. This is the non-switching message delay (see clause 5.14 of [ITU-T G.781]). This delay is due to software processing in the EEC.
- f) The SyncE/SDH transient is rejected by the T-BC after a time interval has elapsed following the receipt of the SSM. This delay is due to software processes in the T-BC; it is approximated as having an upper bound that is equal to the non-switching message delay, i.e., 200 ms in clause 5.14 of [ITU-T G.781] and a lower bound of zero.
- g) There is a 30 ns phase jump at the T-BC input when the SyncE/SDH is rejected and a 60 ns phase jump when it is reacquired (simulations showed that $\max|TE|$ for HRM2, for a chain of 20 T-BCs, could be kept to within 200 ns with these phase jumps).
- h) The initial part of the SyncE/SDH transient is a 7.5 ppm phase ramp over 16 ms, followed by a 50 ns/s phase ramp, followed by a 30 ns phase jump when the SyncE/SDH signal is rejected. Based on (d), (e) and (f), the earliest the rejection can occur is at 0.5 s (500 ms) after the PRC-traceability is lost. The latest the rejection can occur is at 2.4 s (2 400 ms) after PRC-traceability is lost. The 30 ns phase jump can therefore occur anywhere between 500 ms and 2.4 s; to accommodate the worst case, we must take the envelope of all possibilities. For this envelope, we have an initial 7500 ns/s slope until the time error changes by 120 ns, followed by a 50 ns/s slope to time 500 ms, followed by a 30 ns phase step, followed by a 50 ns/s slope to time 2 400 ms. A constant 50 ns phase is added to this entire transient to account for the phase error due to steady-state SyncE/SDH phase noise (see above).
- i) The phase increases described in (g) are assumed to be rapid enough that they are above the 0.1 Hz T-BC filter corner frequency. Since the T-BC filter acts as a high-pass filter on the SyncE/SDH signal, this initial part of the SyncE/SDH transient is passed through the filter approximately unaffected and the effect of the high-pass filtering can be ignored. This assumption is conservative, as accounting for the high-pass filter could only decrease the output phase error.
NOTE – There exist signals for which the zero-to-peak and peak-to-peak values are increased by high-pass filtering, e.g., a square wave whose period is much longer than the high-pass filter time constant, i.e., much smaller than the high-pass filter corner frequency. However, the signal of Figure 12 of [ITU-T G.8262] above is not in this category.
- j) At 2.4 s, the SSM is received by the T-BC and the SyncE/SDH signal is rejected. The T-BC output phase error is an exponential decay with time constant $1/(2\pi \cdot 0.05 \text{ Hz})$ due to the relaxation of the filter.
- k) At time 14.984 s after the start of the transient, the SyncE/SDH undergoes a 120 ns phase change, at a rate of 7.5 ppm and is traceable again. Between 180 ms and 500 ms after this (this is the range for the switching message delay specified in clause 5.14.1 of [ITU-T G.781]), the EEC/SEC sends an SSM indicating this to the T-BC. At some time within 10 s of this, the SyncE/SDH signal is restored and there is a 60 ns phase step, followed by an exponential decay with time constant $1/(2\pi \cdot 0.05 \text{ Hz})$ to the 50 ns level. This means that the 60 ns phase step can occur at any time between $14.984 \text{ s} + 0.18 \text{ s} = 15.164 \text{ s}$,

and $14.984\text{ s} + 0.5\text{ s} + 10\text{ s} = 25.484\text{ s}$. The resulting mask will be taken as the upper envelope of all possible 60 ns phase steps in the range 15.164-25.484 s, with each phase step followed by an exponential decay.

The following assumptions were made in computing the T-BC output phase error due to the SyncE/SDH rearrangement, using the second technique, i.e., turning off the T-BC filter:

- l) This assumption is the same as assumption (a) above for rejection of the SyncE/SDH signal.
- m) This assumption is the same as assumption (b) above for rejection of the SyncE/SDH signal.
- n) This assumption is the same as assumption (c) above for rejection of the SyncE/SDH signal.
- o) This assumption is the same as assumption (d) above for rejection of the SyncE/SDH signal.
- p) This assumption is the same as assumption (e) above for rejection of the SyncE/SDH signal.
- q) The T-BC filter is turned off after a time interval has elapsed following the receipt of the SSM. This delay is due to software processes in the T-BC; it is taken to have an upper bound equal to the non-switching message delay, i.e., 200 ms in clause 5.14 of [ITU-T G.781], and a lower bound of zero. When the next Sync message is received, an immediate correction to the time is made. While this Sync message carries the GM time, the T-BC phase error immediately after the correction is not zero because the most recent mean propagation delay computation was, in worst-case, based on previously received Sync and Delay_Req messages whose arrival and departure, respectively, were timestamped during the SyncE/SDH transient. The mean propagation delay is given by $[(T_4 - T_1) - (T_3 - T_2)]/2$. If we assume that the time interval between the receipt of the most recent Sync and the most recent Delay_Req is, in worst-case, two mean Delay_Req intervals, then the error in mean propagation delay is equal to the accumulated phase error over these two mean Delay_Req intervals, divided by 2. This value is $(2)(0.0625\text{ s})(50\text{ ns/s})/2 = 3.125\text{ ns}$. Then, the T-BC phase error due to the SyncE/SDH transient decreases to 3.125 ns above the 50 ns steady-state error, or 53.125 ns, when this next Sync message is received. This occurs at most 0.125 s later, or at 2.525 s (i.e., at most two mean Sync intervals, since it is assumed that the actual time between Sync messages is bounded by 2 mean Sync intervals). When the next Sync message after this one is received, which is at most 0.125 s after 2.525 s, or 2.65 s, the T-BC phase error decreases to 50 ns.
- r) Between 2.65 s and when the SyncE/SDH signal is again traceable, at 14.984 s, the SyncE/SDH signal has a 50 ns/s frequency offset. This means that, since T-BC filtering is turned off, the T-BC phase error increases by $(50\text{ ns/s})(0.125\text{ s}) = 6.25\text{ ns}$ over the interval between successive Sync messages (the inter-message interval is taken as 0.125 s because clause 6.2.8 of [ITU-T G.8275.1] specifies that the actual Sync interval must not exceed two mean Sync intervals). When the next Sync message is received, this component of the phase error decreases to zero and then increases again until the next Sync message is received. The actual output transient over this time interval is a sawtooth. Since, as will be seen later, the time error for the first technique (i.e., rejecting the SyncE/SDH transient) is larger over most of the interval between 2.45 s and 14.984 s, we approximate this component of error by simply adding a constant 6.25 ns. Then, in (q) above, we approximate the error as 59.375 ns in the range 2.525-2.65 s, and 56.25 ns in the range 2.65-14.984 s.

- s) When the SyncE/SDH is again traceable, at 14.984 s, the second 120 ns phase change over 16 ms interval (i.e., a 7500 ppm phase ramp) appears on the T-BC output. This 120 ns phase error lasts for at most 2 Sync intervals (i.e., as indicated above, this is the longest interval that elapses before the next Sync message is received, because clause 6.2.8 of [ITU-T G.8275.1] specifies that the actual Sync interval must not exceed two mean Sync intervals) and then the error is immediately corrected because the T-BC filter is still turned off. The SSM is received between 180 ms and 500 ms later (i.e., in the range 15.164-15.484 s) indicating the SyncE/SDH is again traceable and the T-BC filter is turned back on between 0 and 10 s later (i.e., in the range 15.164-25.484 s). As was the case when the T-BC filter was turned off (see (q) above), there is still phase error due to the fact that the most recent Sync and Delay_Req messages, which were used for the most recent propagation delay measurement, occurred during the transient when the SyncE/SDH reacquires its reference. In this case, the worst-case is when T_2 was taken just when the SyncE/SDH again became traceable, and T_3 was taken 0.125 s later. The phase error during this interval between the T_3 and T_2 timestamps is $[(0.016 \text{ s})(7500 \text{ ns/s}) + (0.125 \text{ s} - 0.016 \text{ s})(0 \text{ ns/s})]/2 = 60 \text{ ns}$. Then, on receipt of the next Sync message after the T-BC filter is turned on, the T-BC phase error decreases to $56.25 \text{ ns} + 60 \text{ ns} = 116.25 \text{ ns}$. When the next Sync message is received 0.125 s after this, the T-BC phase error decreases to 50 ns.

The above assumptions (a) – (q) produce the T-BC output transients given in Tables II.1 and II.2. In addition to these assumptions, the SyncE/SDH signal was assumed to again be PRC-traceable after 15 s. The transients are continued to 50 s after the loss of traceability. The transients are shown in Figure II.1.

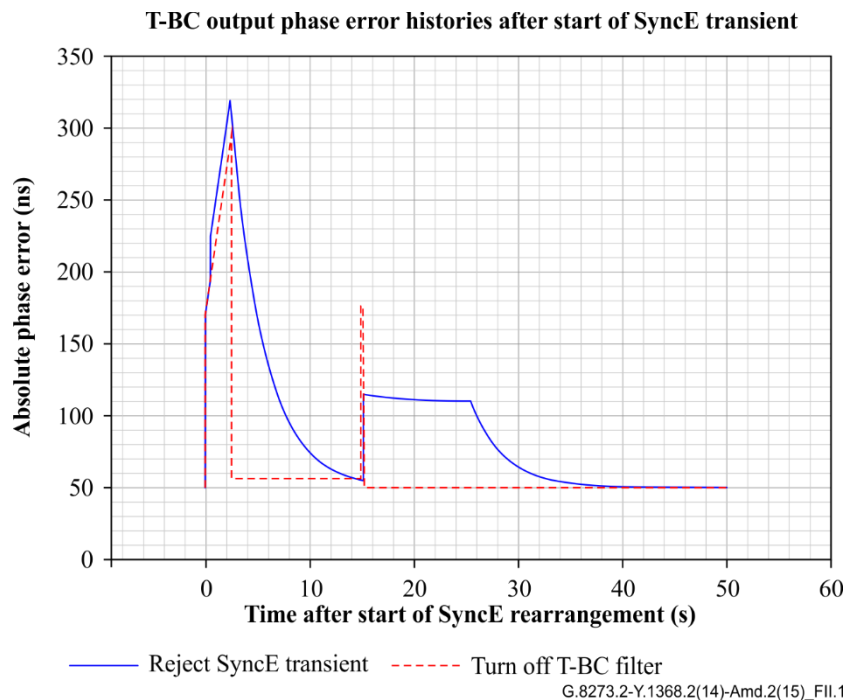

Figure II.1 – T-BC output phase error histories for each of the two techniques, assuming SyncE/SDH transient starts at time zero

**Table II.1 – T-BC output phase error history using scheme
(a) (rejection of SyncE/SDH transient)**

Time S after start of SyncE/SDH rearrangement (s)	T-BC output absolute phase error (ns)
$0 \leq S < 0.016$	$50 + 7500S$
$0.016 \leq S < 0.5$	$170 + 50(S - 0.016)$
$0.5 \leq S < 2.4$	$224.2 + 50(S - 0.5)$
$2.4 \leq S < 15.164$	$50 + 269.2e^{-2\pi(0.05)(S - 2.4)}$
$15.164 \leq S \leq 25.484$	$110 + 269.2 e^{-2\pi(0.05)(S - 2.4)}$
$25.484 \leq S \leq 50$	$50 + 60.193 e^{-2\pi(0.05)(S - 25.484)}$

**Table II.2 – T-BC output phase error history using scheme
(b) (turning off T-BC filter during SyncE/SDH transient)**

Time S after start of SyncE/SDH rearrangement (s)	T-BC output absolute phase error (ns)
$0 \leq S < 0.016$	$50 + 7500S$
$0.016 \leq S < 2.525$	$170 + 50(S - 0.016)$
$2.525 \leq S < 2.65$	59.375
$2.65 \leq S < 14.984$	56.25
$14.984 \leq S < 15.0$	$56.25 + 7500(S - 14.984)$
$15.0 \leq S < 15.125$	176.25
$15.125 \leq S < 15.25$	116.25
$15.25 \leq S \leq 50$	50

Figure II.1 and Table II.2 show that the output transient for scheme (b) (turning off the T-BC filter during the transient) contains a very sharp, narrow peak between 14.984 s and 15.25 s, i.e., over a period of 0.266 s. This peak is due to the second phase jump of 120 ns beginning at 14.984 s and ending at 15 s. In a test, the test set would have to begin and end the phase jump at exactly these times, otherwise the actual peak would occur at slightly different times and the equipment might fail. It would be desirable to allow some margin for the test set; this can be done by allowing the phase jump to begin as early as 14.5 s and end as late as 15.5 s (i.e., allow the phase jump to occur at any time during a 1 s interval). If this is done, the mask for scheme (b) must be computed as the envelope of all possible output transients with the second phase jump occurring during this interval. The modified output mask for scheme (b) is shown in Figure II.2 and Table II.3.

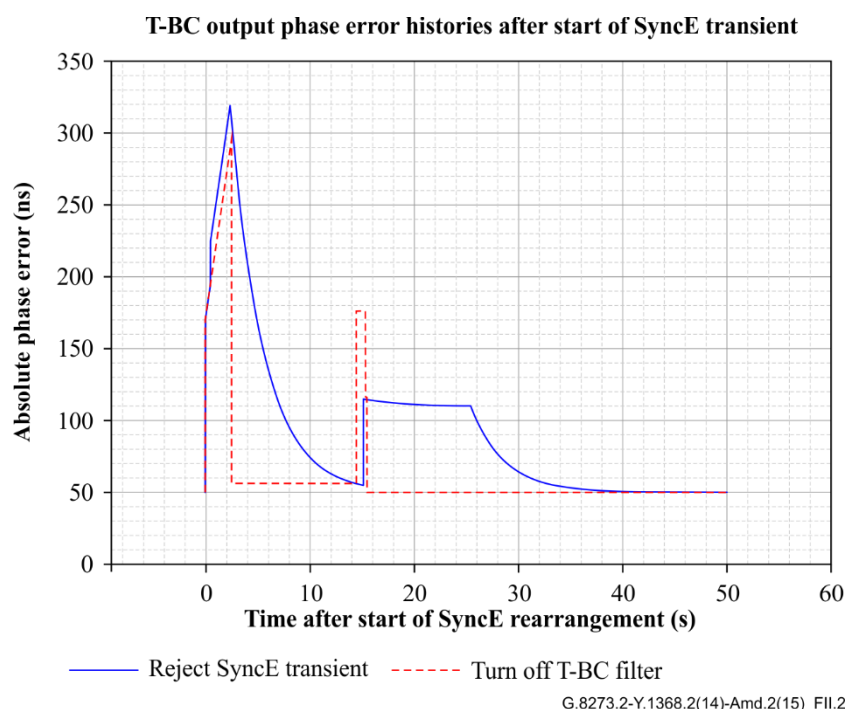

Figure II.2 – T-BC output phase error histories for each of the two techniques, assuming SyncE/SDH transient starts at time zero, and allowing 1 s of margin for the time of second 120 ns phase jump for scheme (b)

Table II.3 – Modified T-BC output phase error history using scheme (b) (turning off T-BC filter during SyncE/SDH transient), allowing 1 s of margin for time of second 120 ns phase jump

Time S after start of SyncE/SDH rearrangement (s)	T-BC output absolute phase error (ns)
$0 \leq S < 0.016$	$50 + 7500S$
$0.016 \leq S < 2.525$	$170 + 50(S - 0.016)$
$2.525 \leq S < 2.65$	59.375
$2.65 \leq S < 14.5$	56.25
$14.5 \leq S < 14.516$	$56.25 + 7500(S - 14.5)$
$14.516 \leq S < 15.375$	176.25
$15.375 \leq S < 15.5$	116.25
$15.5 \leq S \leq 50$	50

Finally, note that the Figure II.2 and Table II.3 mask is still somewhat complex for observation intervals in the range 14.5-15.5 s. The mask can be simplified by allowing it to take on the maximum level in this range, i.e., 176.25 ns. The result is given in Figure II.3 and Table II.4.

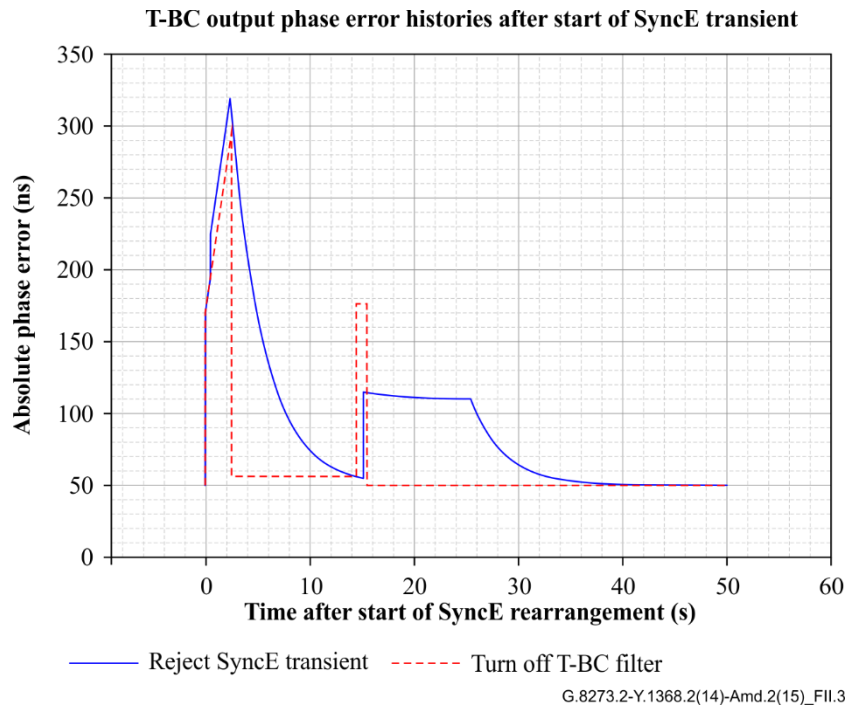

Figure II.3 – T-BC output phase error histories for each of the two techniques, assuming SyncE/SDH transient starts at time zero, and allowing 1 s of margin for the time of second 120 ns phase jump for scheme (b)

Table II.4 – Modified T-BC output phase error history using scheme (b) (turning off T-BC filter during SyncE/SDH transient), allowing 1 s of margin for time of second 120 ns phase jump

Time S after start of SyncE/SDH rearrangement (s)	T-BC output absolute phase error (ns)
$0 \leq S < 0.016$	$50 + 7500S$
$0.016 \leq S < 2.525$	$170 + 50(S - 0.016)$
$2.525 \leq S < 2.65$	59.375
$2.65 \leq S < 14.5$	56.25
$14.5 \leq S < 15.5$	176.25
$15.5 \leq S \leq 50$	50

II.2 T-BC output phase transient mask

The T-BC output phase transient mask is taken as the upper envelope of the two output transients of Tables II.1 and II.4 and Figure II.3 above. This is given by the mask of Figure II.4 and Table II.5 below.

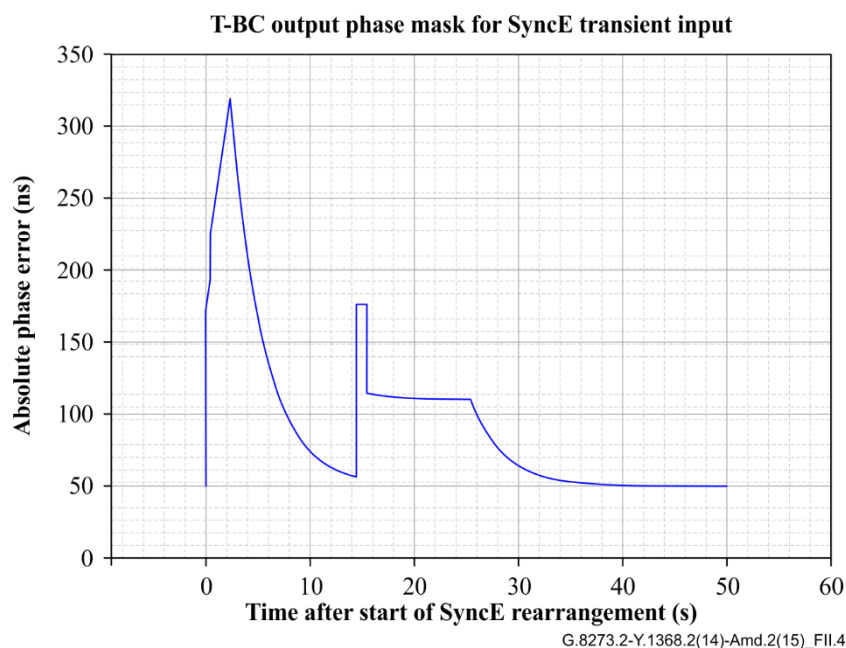

Figure II.4 – Upper envelope of masks of Figure II.3 and Table II.4

Table II.5 – Upper envelope of masks of Figure II.3 and Table II.4

Time S after start of SyncE/SDH rearrangement (s)	T-BC output absolute phase error (ns)
$0 \leq S < 0.016$	$50 + 7500S$
$0.016 \leq S < 0.5$	$170 + 50(S - 0.016)$
$0.5 \leq S < 2.4$	$224.2 + 50(S - 0.5)$
$2.4 \leq S < 14.3776$	$50 + 269.2e^{-2\pi(0.05)(S - 2.4)}$
$14.3776 \leq S \leq 14.5$	56.25
$14.5 \leq S < 15.5$	176.25
$15.5 \leq S < 25.484$	$110 + 269.2 e^{-2\pi(0.05)(S - 2.4)}$
$25.484 \leq S \leq 50$	$50 + 60.193 e^{-2\pi(0.05)(S - 25.484)}$

Further simplifications are possible. First, in Figure II.4 and Table II.5, the limit of 56.25 ns for observation intervals between 14.3776 s and 14.5 s is of very short duration. The mask can be simplified by extending the limit of 176.25 ns, currently for observation intervals between 14.3776 s and 14.5 s, to the range 14.3776-14.5 s and rounding the lower end of the range to 14.25 s. The result is given by the mask of Figure II.5 and Table II.6 below.

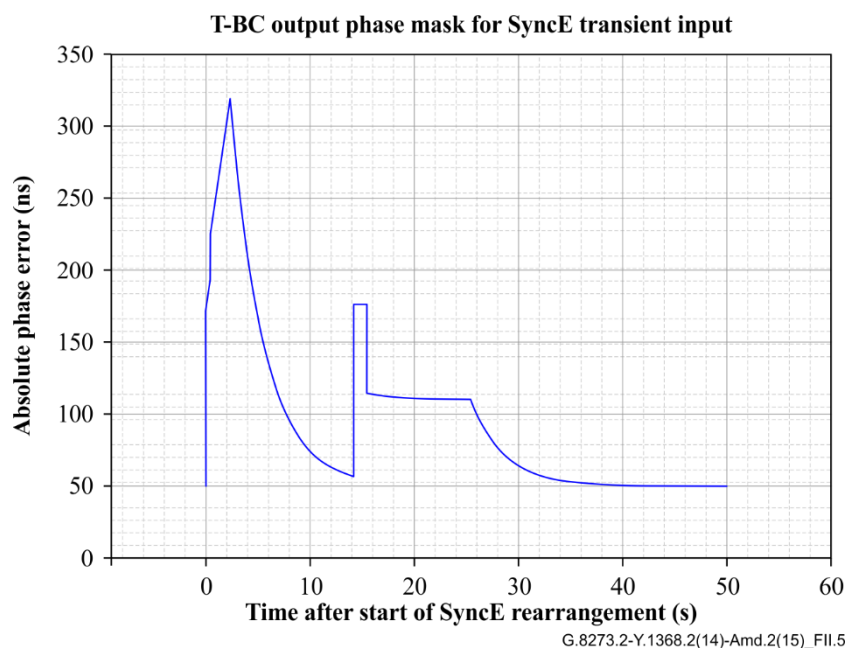

Figure II.5 – Upper envelope of masks of Figure II.3 and Table II.4 after applying simplifications in the range 14.25-14.5 s

Table II.6 – Upper envelope of masks of Figure II.3 and Table II.4 after applying simplifications in the range 14.25-14.5 s

Time S after start of SyncE/SDH rearrangement (s)	T-BC output absolute phase error (ns)
$0 \leq S < 0.016$	$50 + 7500S$
$0.016 \leq S < 0.5$	$170 + 50(S - 0.016)$
$0.5 \leq S < 2.4$	$224.2 + 50(S - 0.5)$
$2.4 \leq S < 14.25$	$50 + 269.2e^{-2\pi(0.05)(S - 2.4)}$
$14.25 \leq S < 15.5$	176.25
$15.5 \leq S < 25.484$	$110 + 269.2 e^{-2\pi(0.05)(S - 2.4)}$
$25.484 \leq S \leq 50$	$50 + 60.193 e^{-2\pi(0.05)(S - 25.484)}$

Second, the portion of the mask in the third region, which extends from 0.5 s to 2.4 s, may be extended into the first two regions (0 to 0.5 s). This will increase the mask in the first two regions. However, note that the mask already increases rapidly during the first 0.5 s and that 170 ns of the increase occurs over the first 0.016 s. Third, values are rounded up to at most three significant figures. Fourth, the second to last region, which extends from 15.5 s to 25.484 s, is replaced by the maximum value of the mask in this region, i.e., 115 ns after the rounding up described above. This may be done because the total decay in the value of the mask in this region is less than 5 ns. The final result is given by the mask of Figure B.1 and Table B.1 of Annex B of this Recommendation.

Appendix III

Background to performance requirements of the T-BC

(This appendix does not form an integral part of this Recommendation.)

Annex A describes a detailed model of a telecom boundary clock. Figure III.1 is a simpler representation showing the timing signal flows between the main functional blocks during normal operation.

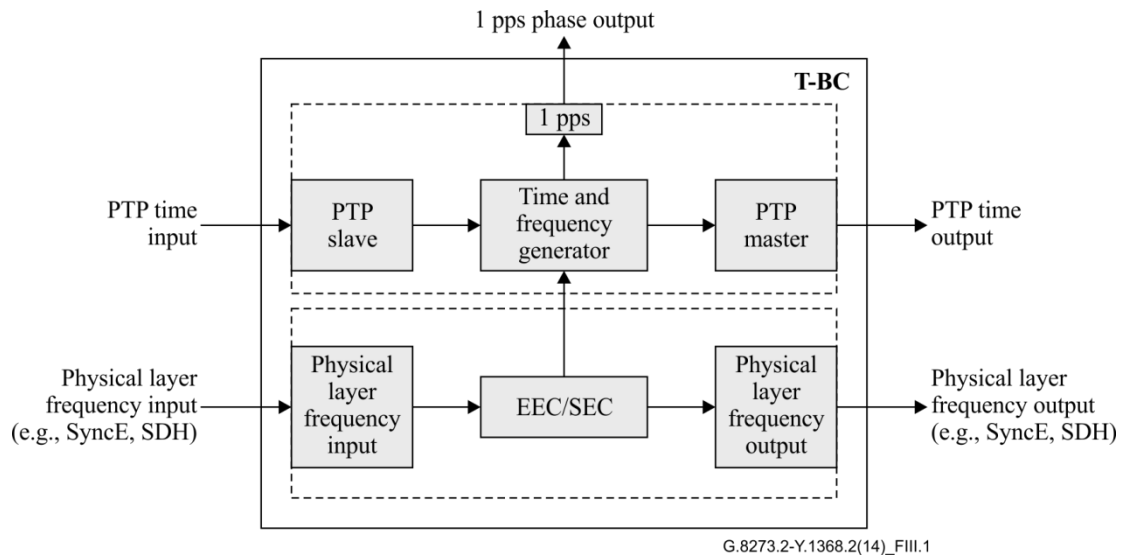

Figure III.1 – Model of T-BC showing signal flows in normal operation

From this diagram, it can be seen that there are basically two clocks in a T-BC, a frequency clock locked to the physical layer frequency input, and a time clock locked to the PTP input. In most cases, the frequency reference is SyncE based rather than SDH or PDH, and hence the frequency clock is an EEC. The two clocks are shown in Figure III.2:

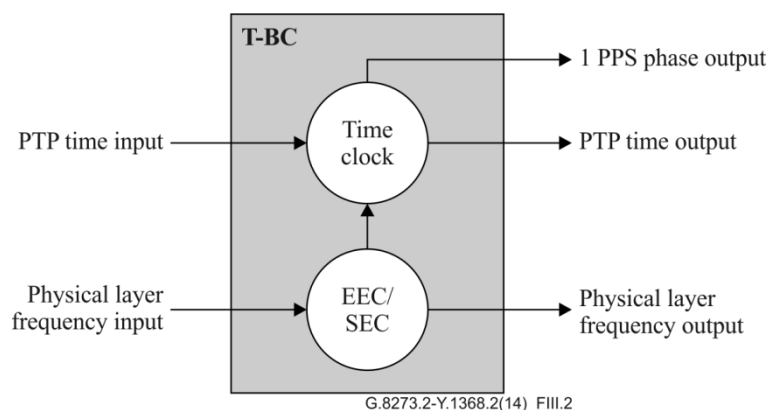

Figure III.2 – Simplified model of T-BC showing clocks

Since the 1 PPS output is a measurement point intended to reflect the performance of the time clock, it is expected that it should be broadly equivalent to the PTP output, aside from the different noise characteristics of the respective signal types.

Therefore there are three primary timing flows in a T-BC:

- 1) PTP time input to PTP and 1 PPS time/phase outputs;
- 2) physical layer frequency input to physical layer frequency output;
- 3) physical layer frequency input to PTP and 1 PPS outputs.

III.1 Noise generation requirements

The noise generation of a clock is defined as the noise (normally phase wander) at the output of the clock, with a wander-free reference at the input of the clock.

The noise generation at the physical layer frequency output is only affected by the physical layer frequency input and is defined by [ITU-T G.8262] and [ITU-T G.813], the clock specifications for an EEC or SEC respectively.

The PTP and 1 PPS signals are the output of the time clock within the T-BC. For these outputs noise basically means time error. This can be defined by three parameters:

- 1) cTE – the mean value of the time error function, measured over a long observation interval;
- 2) dTE – the variation of the time error function;
- 3) maximum time error ($\max|TE|$) – the maximum absolute value of the time error.

For a T-BC, the maximum noise generation is defined in terms of cTE and dTE. The $\max|TE|$ parameter is generally used for network limits.

There are two inputs that can affect the output of the Time Clock, the physical layer frequency input and the PTP input. Therefore the noise generation at the PTP and 1 PPS outputs is defined as the noise present at the output with a time-error free time reference at the PTP input, and a wander-free frequency reference at the physical layer frequency input. This is shown in Figure III.3:

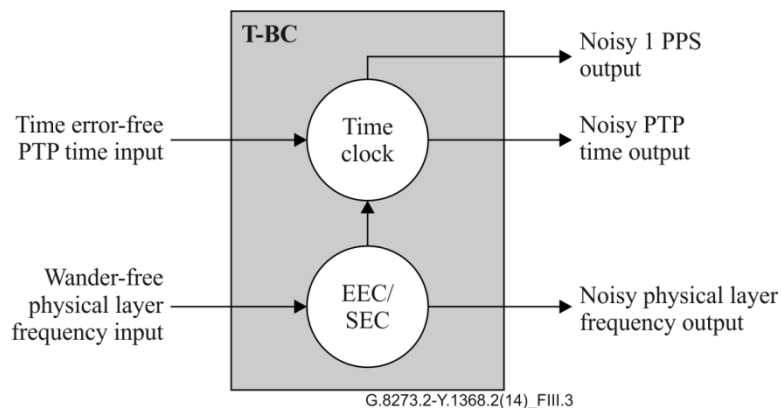

Figure III.3 – Noise generation of a T-BC

III.2 Noise tolerance

The noise tolerance of a T-BC is the maximum level of noise at the inputs of a T-BC that must be tolerated while continuing to work normally. In the real network, both inputs of a clock may be noisy at the same time, therefore the noise tolerance requirements are defined to apply simultaneously on both inputs.

For the PTP input, noise tolerance is defined in terms of the dTE of the input signal. cTE is not considered, since PTP is effectively "blind" to cTE; it cannot detect constant time error at its input without additional information (e.g., asymmetry measurements). The amount of dTE is based on network limit in [ITU-T G.8271.1].

For the physical layer frequency input, the maximum phase wander that should be tolerated is described in [ITU-T G.8262].

There are no output performance requirements on the output of the T-BC during a noise tolerance test. This is because the T-BC is a node within a chain. The noise accumulation through the chain is governed by the noise generation of the clock, and the network limits provide the overall limit on the performance of the chain. A clock is merely expected to work normally during a noise tolerance test, i.e., not switch references, generate any alarms, or go into holdover.

Noise tolerance is shown in Figure III.4:

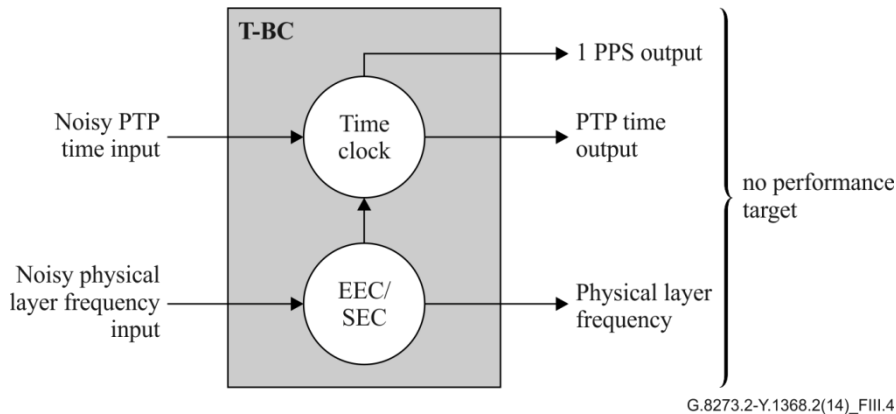

Figure III.4 – Noise tolerance of a T-BC

III.3 Noise transfer

The noise transfer of a clock describes how any noise present on the input of a clock is passed to the output of the clock. It is basically the transfer function of the clock, and is usually expressed in terms of bandwidth, since the clock acts a filter to the noise.

As discussed before, there are three primary signal flows through a T-BC, as shown in Figure III.5:

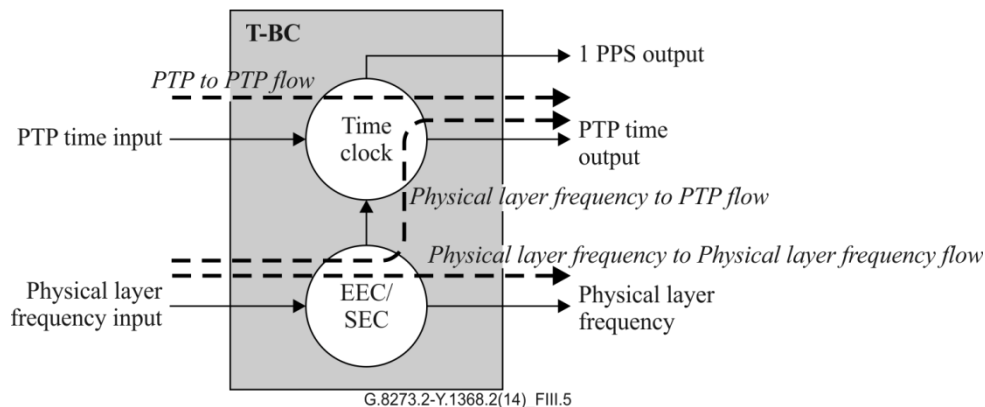

Figure III.5 – Signal flows through a T-BC

Each of these flows has a bandwidth associated with it. The PTP to PTP (and PTP to 1 PPS) bandwidth is explicitly defined in clause 7.3.1, as a low-pass filter with a maximum bandwidth of 0.1 Hz, and a minimum bandwidth of 0.05 Hz.

The physical layer to physical layer frequency bandwidth is defined in [ITU-T G.8262] and [ITU-T G.813], as this is a standard EEC and SEC function respectively. This is also a low-pass filter, with a maximum bandwidth of 10 Hz, and a minimum bandwidth of 1 Hz.

For the physical layer frequency to PTP (and physical layer frequency to 1 PPS) path, the physical layer frequency signal is first low-pass filtered by the EEC or SEC, then high-pass filtered by the time clock. This is because the time clock acts a low-pass filter to its time input, but a high-pass filter to its frequency input. This is a natural consequence of how the clock functions, basically it follows the time input at low frequencies, to stay locked to the time reference, but follows the frequency input at high frequencies (e.g., in between PTP packets, the frequency input provides the "ticking" to maintain the time output).

Therefore the cumulative effect is a band-pass function, with the lower cutoff at 0.05-0.1 Hz, and the upper cutoff at 1-10 Hz. Table III.1 summarizes the transfer functions, while Figure III.6 shows generalized schematics of the transfer functions.

Table III.1 – Transfer functions applicable to a T-BC

Input/output on the T-BC	Transfer function
PTP input to PTP output PTP input to 1 PPS output	0.05-0.1 Hz low-pass filter
Physical layer frequency input to physical layer frequency output	1-10 Hz low-pass filter
Physical layer frequency input to PTP output Physical layer frequency input to 1 PPS output	[0.05-0.1; 1-10] Hz band-pass filter (NOTE 1)

NOTE 1 – The band-pass filter description of the system behaviour from physical layer input to PTP/1_PPS output is representative of the expected behaviour. See Notes in clause 7.3.2 and clause C.2.3.2.

- a) PTP to PTP (or 1 PPS) transfer function schematic
- b) Physical layer frequency to physical layer frequency transfer function schematic
- c) Physical layer frequency to PTP (or 1 PPS) transfer function schematic

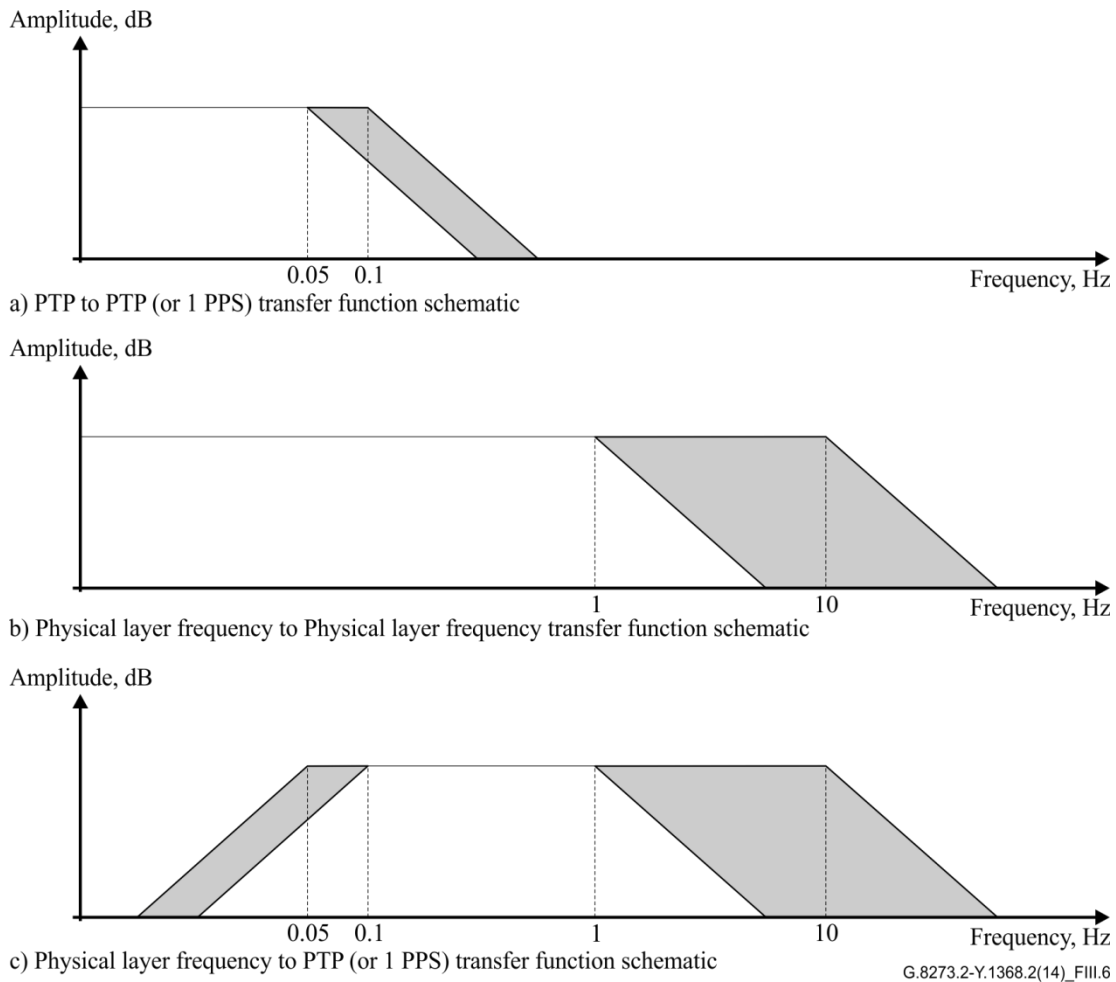

Figure III.6 – Generalized transfer function schematics of a T-BC

It should be noted that the diagrams in Figure III.6 are generalized schematics. The actual transfer function will be more rounded, and include the gain peaking defined in clause 7.3. In particular, the band-pass filter may not contain a flat area due to the closeness of the low-pass and high-pass corner frequencies.

III.4 Holdover

There are two types of holdover available in a T-BC. The first is where the T-BC loses its PTP time reference, but not the physical layer frequency reference, as shown in Figure III.7. In this case, the stable frequency reference is used to keep the time output "ticking" at approximately the correct rate. Since the long-term frequency of the physical layer frequency is traceable to a PRC, this is likely to maintain the correct time over a reasonable period of time.

The performance requirements to be met in this physical layer frequency-assisted holdover mode are not defined at present, and are for further study.

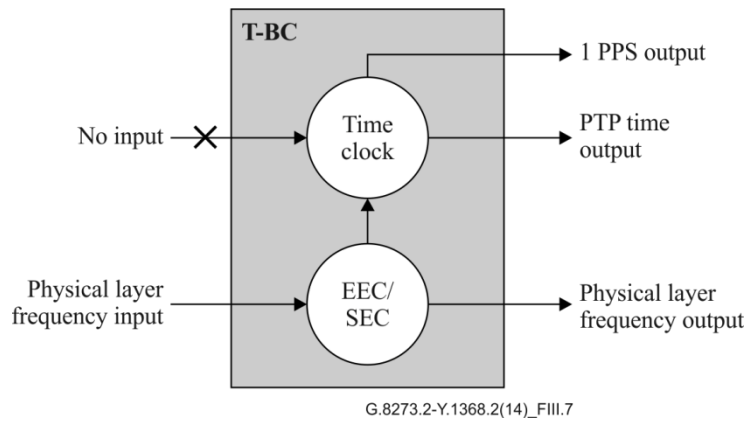

Figure III.7 – Physical layer frequency-assisted holdover

The second type is where both inputs are lost simultaneously, as shown in Figure III.8. The time output is then maintained using the local oscillator, but this is not expected to maintain accurate time for more than a few seconds, due to the drift rate of the oscillator. The performance requirements to meet in unassisted holdover are for further study.

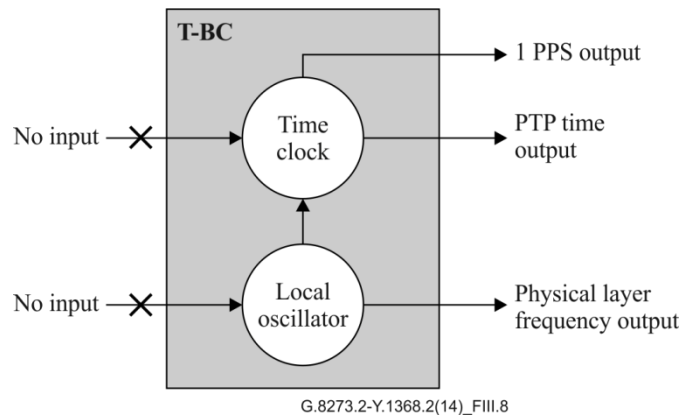

Figure III.8 – Unassisted holdover

Appendix IV

Consideration on slave clocks embedded in end applications

(This appendix does not form an integral part of this Recommendation.)

A time synchronization deployment is comprised of many network clocks such as primary reference time clocks (PRTC), T-GM, T-BC, T-TSC and end application time clocks. Two time synchronization deployment cases are shown in Figure 7-1 of [ITU-T G.8271.1]. In those deployment cases there is an 'end application time clock' that is shown as providing the output clock at interface D. The requirements of these end application time clocks and the performance at interface D is outside the scope of this Recommendation.

When the T-TSC is embedded inside the end application, as shown in deployment case 1 of Figure 7-1 of [ITU-T G.8271.1] the combination of the T-TSC and the end application time clock is implementation specific, where the combined performance may not behave as a stand-alone T-TSC described in this Recommendation. The T-TSC output interfaces may not be available external to the equipment for measurement.

In many end applications there is a need to have coherent frequency and time synchronization and/or to generate coherent frequency and time outputs. In such cases, it is important to properly design the end application time clock to implement the coherency.

Appendix V

Performance Estimation for Cascaded Media Converters acting as T-BCs

(This appendix does not form an integral part of this Recommendation.)

[ITU-T G.8273] describes the "back-to-back" testing of devices such as media converters, where the connecting interface may not be Ethernet and hence a suitable tester may not be available. This appendix discusses how to estimate the budget to use for back-to-back testing of such devices, where each device is allocated the budget equivalent to a single T-BC.

V.1 Noise generation

The budget for the noise generation of a pair of cascaded T-BCs can be estimated as follows:

- 1) Constant time error limit (cTE)
cTE adds linearly in a chain of devices. For example, if each device has a cTE of 50ns, the total cTE after two devices will be 100 ns.
- 2) Dynamic time error limit – low pass filtered (dTE_L)
dTE_L adds with the RMS value of the noise power.
For MTIE this approximates to a square root law. For example, if each device has a dTE_L of 40ns, the total after two devices will be $\sqrt{2} \cdot 40 = 57$ ns.
For the purposes of this estimation, the value is rounded up to 60 ns.
TDEV accumulates as the square root of the sum of the squares. For example, if each device has a dTE_L of 4ns, the total after two devices will be $\sqrt{(4^2 + 4^2)} = 5.7$ ns.
For the purposes of this estimation, the value is rounded up to 6 ns.
- 3) Dynamic time error limit – high pass filtered (dTE_H)
dTE_H from the first device is mostly removed by filtering in the second device. Therefore the dTE_H of the combination is mainly down to the second device. For example, if each device has a dTE_H of 70ns, the total after two devices will be still be 70 ns.
- 4) Maximum absolute time error limit – unfiltered max|TE|
The maximum absolute time error (max|TE|) of the T-BC is the total time error including all components cTE, dTE_L and dTE_H.
These noise components accumulate as described in points 1-3 above.

Table V.1 summarizes noise generation estimation for a pair of media converters based on the Class A and Class B T-BC noise generation specifications.

Table V.1 – Noise generation estimation for a pair of media converters

	Based on Class A T-BC		Based on Class B T-BC	
	Single T-BC	Pair of media converters	Single T-BC	Pair of media converters
cTE (ns)	±50	±100	±20	±40
dTE _L MTIE (ns)	40	60	40	60
dTE _L TDEV (ns)	4	6	4	6
dTE _H (peak-to-peak, ns)	70	70	70	70
max TE (ns)	100	160	70	100

NOTE 1 – The values for a single Class A and Class B T-BC are defined in clause 7.1 of this Recommendation.

V.2 Noise tolerance

For noise tolerance, the input stimulus should be the same as defined in clause 7.2 of this Recommendation, with none of the cascaded clocks raising alarms, switching references or going into holdover.

V.3 Noise transfer

The noise transfer response of a pair of cascaded clocks is for further study.

The bandwidth of two cascaded clocks is likely to be slightly lower than a single clock, but the reduction is for further study, since the roll-off or order of the filter is not specified in clause 7.3.

V.4 Transient response and holdover performance

The transient response and holdover performance of pair of cascaded clocks is for further study.

For the holdover performance with physical layer frequency assistance (as defined in clause 7.4.2.1), the performance will depend on whether the physical layer frequency signal is still available if the technology-dependent interface fails.

ITU-T Y-SERIES RECOMMENDATIONS

GLOBAL INFORMATION INFRASTRUCTURE, INTERNET PROTOCOL ASPECTS, NEXT-GENERATION NETWORKS, INTERNET OF THINGS AND SMART CITIES

GLOBAL INFORMATION INFRASTRUCTURE	
General	Y.100–Y.199
Services, applications and middleware	Y.200–Y.299
Network aspects	Y.300–Y.399
Interfaces and protocols	Y.400–Y.499
Numbering, addressing and naming	Y.500–Y.599
Operation, administration and maintenance	Y.600–Y.699
Security	Y.700–Y.799
Performances	Y.800–Y.899
INTERNET PROTOCOL ASPECTS	
General	Y.1000–Y.1099
Services and applications	Y.1100–Y.1199
Architecture, access, network capabilities and resource management	Y.1200–Y.1299
Transport	Y.1300–Y.1399
Interworking	Y.1400–Y.1499
Quality of service and network performance	Y.1500–Y.1599
Signalling	Y.1600–Y.1699
Operation, administration and maintenance	Y.1700–Y.1799
Charging	Y.1800–Y.1899
IPTV over NGN	Y.1900–Y.1999
NEXT GENERATION NETWORKS	
Frameworks and functional architecture models	Y.2000–Y.2099
Quality of Service and performance	Y.2100–Y.2199
Service aspects: Service capabilities and service architecture	Y.2200–Y.2249
Service aspects: Interoperability of services and networks in NGN	Y.2250–Y.2299
Enhancements to NGN	Y.2300–Y.2399
Network management	Y.2400–Y.2499
Network control architectures and protocols	Y.2500–Y.2599
Packet-based Networks	Y.2600–Y.2699
Security	Y.2700–Y.2799
Generalized mobility	Y.2800–Y.2899
Carrier grade open environment	Y.2900–Y.2999
FUTURE NETWORKS	Y.3000–Y.3499
CLOUD COMPUTING	Y.3500–Y.3999
INTERNET OF THINGS AND SMART CITIES AND COMMUNITIES	
General	Y.4000–Y.4049
Definitions and terminologies	Y.4050–Y.4099
Requirements and use cases	Y.4100–Y.4249
Infrastructure, connectivity and networks	Y.4250–Y.4399
Frameworks, architectures and protocols	Y.4400–Y.4549
Services, applications, computation and data processing	Y.4550–Y.4699
Management, control and performance	Y.4700–Y.4799
Identification and security	Y.4800–Y.4899
Evaluation and assessment	Y.4900–Y.4999

For further details, please refer to the list of ITU-T Recommendations.

SERIES OF ITU-T RECOMMENDATIONS

Series A	Organization of the work of ITU-T
Series D	Tariff and accounting principles and international telecommunication/ICT economic and policy issues
Series E	Overall network operation, telephone service, service operation and human factors
Series F	Non-telephone telecommunication services
Series G	Transmission systems and media, digital systems and networks
Series H	Audiovisual and multimedia systems
Series I	Integrated services digital network
Series J	Cable networks and transmission of television, sound programme and other multimedia signals
Series K	Protection against interference
Series L	Environment and ICTs, climate change, e-waste, energy efficiency; construction, installation and protection of cables and other elements of outside plant
Series M	Telecommunication management, including TMN and network maintenance
Series N	Maintenance: international sound programme and television transmission circuits
Series O	Specifications of measuring equipment
Series P	Telephone transmission quality, telephone installations, local line networks
Series Q	Switching and signalling, and associated measurements and tests
Series R	Telegraph transmission
Series S	Telegraph services terminal equipment
Series T	Terminals for telematic services
Series U	Telegraph switching
Series V	Data communication over the telephone network
Series X	Data networks, open system communications and security
Series Y	Global information infrastructure, Internet protocol aspects, next-generation networks, Internet of Things and smart cities
Series Z	Languages and general software aspects for telecommunication systems