

Recommendation

## **ITU-T G.8275 (01/2024)**

SERIES G: Transmission systems and media, digital systems and networks

Packet over Transport aspects – Synchronization, quality and availability targets

---

**Architecture and requirements for packet-based time and phase distribution**



ITU-T G-SERIES RECOMMENDATIONS  
**Transmission systems and media, digital systems and networks**

INTERNATIONAL TELEPHONE CONNECTIONS AND CIRCUITS	G.100-G.199
GENERAL CHARACTERISTICS COMMON TO ALL ANALOGUE CARRIER-TRANSMISSION SYSTEMS	G.200-G.299
INDIVIDUAL CHARACTERISTICS OF INTERNATIONAL CARRIER TELEPHONE SYSTEMS ON METALLIC LINES	G.300-G.399
GENERAL CHARACTERISTICS OF INTERNATIONAL CARRIER TELEPHONE SYSTEMS ON RADIO-RELAY OR SATELLITE LINKS AND INTERCONNECTION WITH METALLIC LINES	G.400-G.449
COORDINATION OF RADIOTELEPHONY AND LINE TELEPHONY	G.450-G.499
TRANSMISSION MEDIA AND OPTICAL SYSTEMS CHARACTERISTICS	G.600-G.699
DIGITAL TERMINAL EQUIPMENTS	G.700-G.799
DIGITAL NETWORKS	G.800-G.899
DIGITAL SECTIONS AND DIGITAL LINE SYSTEM	G.900-G.999
MULTIMEDIA QUALITY OF SERVICE AND PERFORMANCE – GENERIC AND USER-RELATED ASPECTS	G.1000-G.1999
TRANSMISSION MEDIA CHARACTERISTICS	G.6000-G.6999
DATA OVER TRANSPORT – GENERIC ASPECTS	G.7000-G.7999
PACKET OVER TRANSPORT ASPECTS	G.8000-G.8999
Ethernet over Transport aspects	G.8000-G.8099
MPLS over Transport aspects	G.8100-G.8199
<b>Synchronization, quality and availability targets</b>	<b>G.8200-G.8299</b>
Mobile network transport aspects	G.8300-G.8399
Service Management	G.8600-G.8699
ACCESS NETWORKS	G.9000-G.9999

*For further details, please refer to the list of ITU-T Recommendations.*

# Recommendation ITU-T G.8275

## Architecture and requirements for packet-based time and phase distribution

### Summary

Recommendation ITU-T G.8275 describes the architecture and requirements for packet-based time and phase distribution in telecom networks. The architecture described is mainly applicable to the use of IEEE 1588. Details necessary to utilize IEEE 1588 in a manner consistent with the architecture are defined in other Recommendations.

### History\*

Edition	Recommendation	Approval	Study Group	Unique ID
1.0	ITU-T G.8275/Y.1369	2013-11-22	15	11.1002/1000/12011
1.1	ITU-T G.8275/Y.1369 (2013) Amd. 1	2015-01-13	15	11.1002/1000/12396
1.2	ITU-T G.8275/Y.1369 (2013) Amd. 2	2016-04-13	15	11.1002/1000/12814
2.0	ITU-T G.8275/Y.1369	2017-08-13	15	11.1002/1000/13328
2.1	ITU-T G.8275/Y.1369 (2017) Amd. 1	2018-11-29	15	11.1002/1000/13771
2.2	ITU-T G.8275/Y.1369 (2017) Amd. 2	2019-08-29	15	11.1002/1000/14016
3.0	ITU-T G.8275/Y.1369	2020-10-29	15	11.1002/1000/14509
3.1	ITU-T G.8275/Y.1369 (2020) Amd. 1	2021-05-29	15	11.1002/1000/14627
3.2	ITU-T G.8275/Y.1369 (2020) Amd. 2	2022-02-13	15	11.1002/1000/14905
3.3	ITU-T G.8275/Y.1369 (2020) Amd. 3	2022-11-13	15	11.1002/1000/15155
4.0	ITU-T G.8275	2024-01-13	15	11.1002/1000/15845

### Keywords

Architecture, IEEE 1588, packet, phase, PTP, synchronization, time.

---

\* To access the Recommendation, type the URL <https://handle.itu.int/> in the address field of your web browser, followed by the Recommendation's unique ID.

## FOREWORD

The International Telecommunication Union (ITU) is the United Nations specialized agency in the field of telecommunications, information and communication technologies (ICTs). The ITU Telecommunication Standardization Sector (ITU-T) is a permanent organ of ITU. ITU-T is responsible for studying technical, operating and tariff questions and issuing Recommendations on them with a view to standardizing telecommunications on a worldwide basis.

The World Telecommunication Standardization Assembly (WTSA), which meets every four years, establishes the topics for study by the ITU-T study groups which, in turn, produce Recommendations on these topics.

The approval of ITU-T Recommendations is covered by the procedure laid down in WTSA Resolution 1.

In some areas of information technology which fall within ITU-T's purview, the necessary standards are prepared on a collaborative basis with ISO and IEC.

## NOTE

In this Recommendation, the expression "Administration" is used for conciseness to indicate both a telecommunication administration and a recognized operating agency.

Compliance with this Recommendation is voluntary. However, the Recommendation may contain certain mandatory provisions (to ensure, e.g., interoperability or applicability) and compliance with the Recommendation is achieved when all of these mandatory provisions are met. The words "shall" or some other obligatory language such as "must" and the negative equivalents are used to express requirements. The use of such words does not suggest that compliance with the Recommendation is required of any party.

## INTELLECTUAL PROPERTY RIGHTS

ITU draws attention to the possibility that the practice or implementation of this Recommendation may involve the use of a claimed Intellectual Property Right. ITU takes no position concerning the evidence, validity or applicability of claimed Intellectual Property Rights, whether asserted by ITU members or others outside of the Recommendation development process.

As of the date of approval of this Recommendation, ITU had received notice of intellectual property, protected by patents/software copyrights, which may be required to implement this Recommendation. However, implementers are cautioned that this may not represent the latest information and are therefore strongly urged to consult the appropriate ITU-T databases available via the ITU-T website at <http://www.itu.int/ITU-T/ipr/>.

© ITU 2024

All rights reserved. No part of this publication may be reproduced, by any means whatsoever, without the prior written permission of ITU.

## Table of Contents

		Page
1	Scope.....	1
2	References.....	1
3	Definitions .....	2
4	Abbreviations and acronyms .....	2
5	Conventions .....	3
6	General introduction to packet-based time/phase distribution .....	4
	6.1 Requirements for packet-based time and phase distribution.....	4
7	Architecture of packet-based time/phase distribution .....	4
	7.1 Packet-based time and phase distribution.....	5
	7.2 Time/phase protection aspects.....	6
	7.3 Packet network partitioning.....	16
8	Security aspects .....	17
9	Management aspects.....	17
	Annex A – Time/phase models based on ITU-T G.805 .....	18
	Annex B – Inclusion of a virtual PTP port on a PTP clock .....	20
	Annex C – Options to establish the PTP topology with the alternate BTCA .....	22
	Annex D – Synchronization uncertain indication (optional) .....	23
	Annex E – Use of the timeTransmitterOnly and notTimeTransmitter parameters in the networks.....	24
	Annex F – Performance monitoring (optional).....	27
	F.1 Data storage .....	29
	F.2 Use cases when local PTP clock is not used for timestamping.....	31
	F.3 Considerations for [ITU-T G.8275.2] .....	31
	F.4 Time reference information .....	31
	Appendix I – Architecture for time and phase distribution over a packet network providing PTS at the protocol level.....	33
	I.1 Architecture for PTS.....	33
	Appendix II – An example of PRTC switching by the BTCA in a ring network.....	37
	Appendix III – Generic IWF node .....	39
	III.1 Introduction .....	39
	III.2 Inter-working between the [ITU-T G.8275.1] and [ITU-T G.8275.2] profiles.....	40
	III.3 Generation of the physical layer frequency signal by the IWF.....	42
	III.4 Mapping IWF to telecom PTP clocks .....	43
	Appendix IV – Use cases for mapping from PTP clockClass values to quality levels.....	44
	IV.1 Use case I.....	44
	IV.2 Use case II .....	44

	<b>Page</b>
Appendix V – Deployment examples and the use of partially aware deviceTypes.....	46
Appendix VI – cnPRTC functional architecture.....	48
Appendix VII – cnPRTC deployment scenarios.....	49
Appendix VIII – Description of PTP clock modes and associated contents of Announce messages .....	51
VIII.1 Purpose of this appendix .....	51
VIII.2 Description of the modes.....	51
VIII.3 Example of mapping between PTP port states and PTP clock modes for a 3-port T-BC/T-BC-P/T-BC-A .....	52
VIII.4 T-GM Announce message contents based on the internal PTP clock modes	53
VIII.5 T-BC/T-BC-P/T-BC-A Announce message contents based on the internal PTP clock modes .....	54
Appendix IX – Considerations on the use of [IEEE 1588-2019] .....	56
Appendix X – Flexible synchronization network based on cnPRTC .....	57
Appendix XI – Information that can be used in the analysis of the performance monitoring data.....	60
Appendix XII – Updated terminology for PTP clocks and PTP profiles.....	61
Bibliography.....	62

# Recommendation ITU-T G.8275

## Architecture and requirements for packet-based time and phase distribution

### 1 Scope

This Recommendation describes the general architecture of time and phase distribution using packet-based methods. This version of the Recommendation focuses on the distribution of time and phase using the standard for precision time protocol (PTP) [IEEE 1588]. The requirements and architecture form a base for the specification of other functionalities that are needed to achieve packet-based time and phase distribution in a carrier environment. The architecture described covers the case where protocol interaction is at all nodes, between a packet timeTransmitter (pTT) clock and a packet timeReceiver (pTR) clock, or only a subset of the nodes between a pTT clock and a pTR clock. Details of the necessary profiles are described in other Recommendations.

### 2 References

The following ITU-T Recommendations and other references contain provisions which, through reference in this text, constitute provisions of this Recommendation. At the time of publication, the editions indicated were valid. All Recommendations and other references are subject to revision; users of this Recommendation are therefore encouraged to investigate the possibility of applying the most recent edition of the Recommendations and other references listed below. A list of the currently valid ITU-T Recommendations is regularly published. The reference to a document within this Recommendation does not give it, as a stand-alone document, the status of a Recommendation.

- [ITU-T G.805] Recommendation ITU-T G.805 (2000), *Generic functional architecture of transport networks*.
- [ITU-T G.810] Recommendation ITU-T G.810 (1996), *Definitions and terminology for synchronization networks*.
- [ITU-T G.8260] Recommendation ITU-T G.8260 (2022), *Definitions and terminology for synchronization in packet networks*.
- [ITU-T G.8261] Recommendation ITU-T G.8261/Y.1361 (2019), *Timing and synchronization aspects in packet networks*.
- [ITU-T G.8261.1] Recommendation ITU-T G.8261.1/Y.1361.1 (2012), *Packet delay variation network limits applicable to packet-based methods (Frequency synchronization)*.
- [ITU-T G.8262] Recommendation ITU-T G.8262/Y.1362 (2018), *Timing characteristics of a synchronous equipment slave clock*.
- [ITU-T G.8262.1] Recommendation ITU-T G.8262.1/Y.1362.1 (2022), *Timing characteristics of enhanced synchronous equipment slave clock*.
- [ITU-T G.8263] Recommendation ITU-T G.8263/Y.1363 (2017), *Timing characteristics of packet-based equipment clocks*.
- [ITU-T G.8264] Recommendation ITU-T G.8264/Y.1364 (2017), *Distribution of timing information through packet networks*.
- [ITU-T G.8265] Recommendation ITU-T G.8265/Y.1365 (2010), *Architecture and requirements for packet-based frequency delivery*.
- [ITU-T G.8265.1] Recommendation ITU-T G.8265.1/Y.1365.1 (2022), *Precision time protocol telecom profile for frequency synchronization*.

- [ITU-T G.8271] Recommendation ITU-T G.8271/Y.1366 (2020), *Time and phase synchronization aspects of telecommunication networks*.
- [ITU-T G.8271.1] Recommendation ITU-T G.8271.1/Y.1366.1 (2022), *Network limits for time synchronization in packet networks with full timing support from the network*.
- [ITU-T G.8271.2] Recommendation ITU-T G.8271.2/Y.1366.2 (2021), *Network limits for time synchronization in packet networks with partial timing support from the network*.
- [ITU-T G.8272] Recommendation ITU-T G.8272/Y.1367 (2018), *Timing characteristics of primary reference time clocks*.
- [ITU-T G.8275.1] Recommendation ITU-T G.8275.1/Y.1369.1 (2022), *Precision time protocol telecom profile for phase/time synchronization with full timing support from the network*.
- [ITU-T G.8275.2] Recommendation ITU-T G.8275.2/Y.1369.2 (2022), *Precision time protocol telecom profile for phase/time synchronization with partial timing support from the network*.
- [IEEE 1588] References either [IEEE 1588-2008] or [IEEE 1588-2019] depending on the specific implementation. See clause 5, Conventions, for further details.
- [IEEE 1588-2008] IEEE Std 1588-2008, *Standard for a Precision Clock Synchronization Protocol for Networked Measurement and Control Systems*.
- [IEEE 1588-2019] IEEE Std 1588-2019, *Standard for a Precision Clock Synchronization Protocol for Networked Measurement and Control Systems*.

### 3 Definitions

The terms and definitions used in this Recommendation are contained in [ITU-T G.810] and [ITU-T G.8260].

### 4 Abbreviations and acronyms

This Recommendation uses the following abbreviations and acronyms:

APTS	Assisted Partial Timing Support
APTSC	Assisted Partial Timing Support Clock
BC	Boundary Clock
BTCA	Best TimeTransmitter Clock Algorithm
cnPRTC	Coherent Network PRTC
DS	Data Set
EEC	Synchronous Ethernet Equipment Clock
ePRTC	Enhanced PRTC
ESMC	Ethernet Synchronization Messaging Channel
FTS	Full Timing Support
GM	Grandmaster
GNSS	Global Navigation Satellite System
HRM	Hypothetical Reference Model



IWF	Inter-working Function
LTE	Long-Term Evolution
NTP	Network Time Protocol
OTN	Optical Transport Network
PDV	Packet Delay Variation
PPS	Pulse Per Second
PRC	Primary Reference Clock
PRTC	Primary Reference Time Clock
PTP	Precision Time Protocol
PTS	Partial Timing Support
pTR	Packet timeReceiver
pTT	Packet timeTransmitter
QL	Quality Level
SDH	Synchronous Digital Hierarchy
SF	Signal Fail
SSM	Synchronization Status Message
SSU	Synchronization Supply Unit
T-BC	Telecom Boundary Clock
T-GM	Telecom Grandmaster
T-TC	Telecom Transparent Clock
T-TSC	Telecom Time Synchronous Clock
TC	Transparent Clock
ToD	Time of Day
TR	timeReceiver, TimeReceiver, or TIME_RECEIVER
TT	timeTransmitter, TimeTransmitter, or TIME_TRANSMITTER
UTC	Coordinated Universal Time
WCDMA	Wideband Code Division Multiple Access

## 5 Conventions

The architecture within this Recommendation applies to profiles that are specified in other Recommendations. Within those Recommendations, some requirements are stated as requiring compliance to the [IEEE 1588]. For implementations compliant to [IEEE 1588-2008], the reference to [IEEE 1588] means compliance to [IEEE 1588-2008]. For implementations compliant to [IEEE 1588-2019], the reference to [IEEE 1588] means compliance to [IEEE 1588-2019]. Some of these references to [IEEE 1588] include a specific clause number. In these cases, the clause number is the same in both [IEEE 1588-2008] and [IEEE 1588-2019]. If the requirements are in different clauses in the two versions of IEEE 1588, then the text of this Recommendation shall include the specific clause for [IEEE 1588-2008] and the specific cause for [IEEE 1588-2019].

Within this Recommendation, the term PTP refers to the PTP version 2 protocol defined in [IEEE 1588].

## **6 General introduction to packet-based time/phase distribution**

The distribution of accurate time and phase is necessary to support certain telecom-based services and in particular the underlying infrastructure. While traditional network synchronization has relied on the accurate distribution of frequency, evolving wireless networks require the distribution of accurate time and phase.

As the network evolves from a primarily TDM-based network infrastructure to one using packet-based technology, the ability to distribute synchronization is also changing.

In order to enable timing distribution in packet-based networks, the ITU-T developed specifications ([ITU-T G.8261], [ITU-T G.8262] and [ITU-T G.8264]) for synchronous Ethernet, which allowed the use of the Ethernet physical layer to be used as a mechanism to distribute frequency analogous to the methods used with synchronous digital hierarchy (SDH)-based network synchronization. In this regard, synchronous Ethernet, by appropriate specification of network equipment clocks provided support for the existing frequency-based synchronization network over both existing TDM and new packet-based technology.

In the absence of the ability to utilize the physical layer, the ITU also developed Recommendations covering frequency distribution using packet-based methods such as precision time protocol (PTP) and network time protocol (NTP). The use of packet-based methods also enabled new frequency synchronization scenarios to be considered. These, as well as other aspects specific to packet-based frequency distribution, resulted in the development of an architectural specification [ITU-T G.8265].

This Recommendation describes the architecture for packet-based time and phase distribution.

### **6.1 Requirements for packet-based time and phase distribution**

Packet-based mechanisms for time and phase distribution must meet the following five requirements:

- 1) mechanisms must be specified to allow interoperability between the various phase/time clocks defined in this architecture;
- 2) mechanisms must permit consistent operation over managed wide area telecom networks;
- 3) packet-based mechanisms must allow the synchronization network to be designed and configured in a fixed arrangement;
- 4) protection schemes used by packet-based systems must be based on standard telecom operational practice and allow telecom time synchronous clocks (T-TSC) the ability to take phase and time from multiple geographically separate telecom grandmaster (T-GM) clocks;
- 5) phase/time reference source selection based on received phase/time traceability and local priority should be permitted. Automatic establishment of the phase/time synchronization network topology may also be possible.

## **7 Architecture of packet-based time/phase distribution**

In contrast to physical layer synchronization where the significant edges of a data signal define the timing content of the signal, packet-based methods rely on the transmission of dedicated "event packets". These "event packets" form the significant instants of a packet timing signal. The timing of these significant instants is precisely measured relative to a timeTransmitter (TT), and this timing information is encoded in the form of a timestamp, which is a machine-readable representation of a specific instance of time. The timestamp is generated via a pTT function and is carried over a packet network to a pTR clock.

A protocol is used between the timeTransmitter and the timeReceiver (TR) clocks to adjust for transmission and other delays, resulting in both having the same time reference.

As time is the integral of frequency, the timestamps can also be used to derive frequency. This case is covered in [ITU-T G.8265] and [ITU-T G.8265.1].

## 7.1 Packet-based time and phase distribution

A time reference is initially obtained from a primary reference time clock (PRTC). If the time across the system is required to be referenced to the coordinated universal time (UTC) or to some other universal standard source of time, the PRTC itself may require a time reference input such as a global navigation satellite system (GNSS) signal.

For the purposes of time and phase synchronization transport, the pTT delivers its reference to the pTR clock using a packet timing signal (see [ITU-T G.8260]).

In order to achieve better accuracy, protocol-level timing support may be used at various network nodes. Specifically, for the [IEEE 1588] PTP protocol, these intermediate devices are termed boundary clocks (BCs) or transparent clocks (TCs).

The architecture described in this Recommendation describes two cases; the first case is where timing support is provided by all the nodes in the network (e.g., telecom boundary clocks (T-BCs)) with physical layer frequency support ("full timing support to the protocol level" (FTS) (see [ITU-T G.8260]) and the second case is where the intermediate nodes do not provide timing support, but timing support is provided by the GNSS at the network edge, with PTP acting as a backup. This is termed assisted partial timing support (APTS). The node providing support at the edge of the network is called an assisted partial timing support clock (APTSC).

Other architectures where not all of the nodes need to provide timing support by participating in the timing protocol are termed "partial timing support to the protocol level" (PTS) (see [ITU-T G.8260]). Some additional considerations for this topic are documented in Appendix I.

In both types of architectures, the physical layer frequency support may be available to stabilize the operation of the T-BCs or telecom transparent clocks (T-TCs).

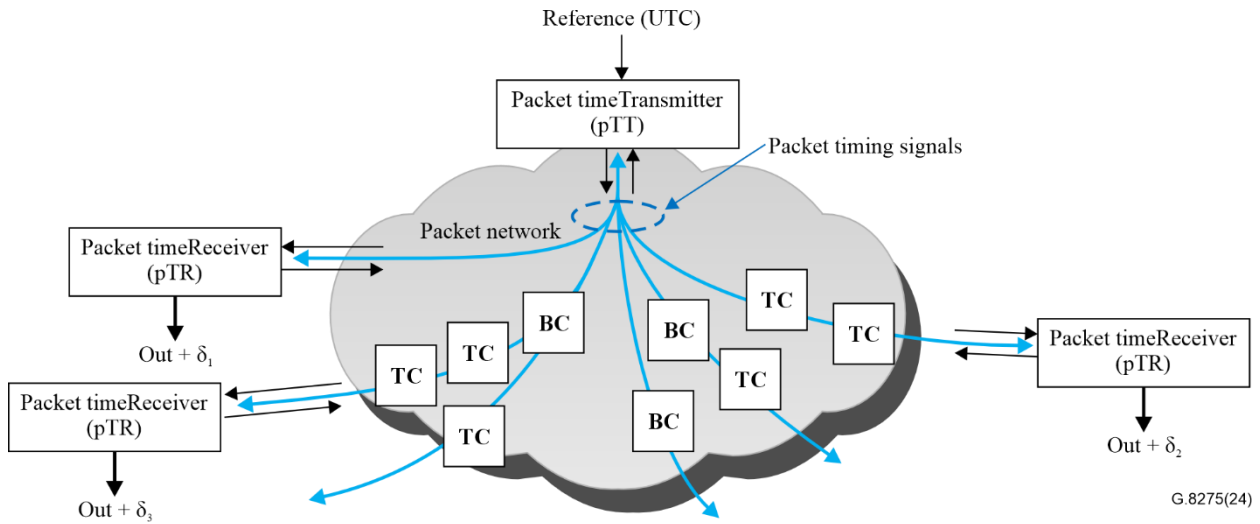
The time-transfer protocol operating between the nodes allows the same time to be recovered or corrected at all the nodes participating in the timing protocol, subject to some degradation ( $\delta$ ).

In some deployments, especially in the access part of the network, it may be convenient to provide timing support from the protocol via T-TC functions. One typical example is in the case of the microwave connections.

NOTE 1 – The T-TCs are typically connected in tree architectures. Rings composed entirely of T-TCs can raise issues in terms of PTP packets loops.

The general network topology for time/phase distribution from a PRTC to a T-TSC is shown in Figure 1. The synchronization flow is from the timeTransmitter clock to the timeReceiver clock, although the timing messages will flow in both directions. Individual nodes are T-BCs or T-TCs in the case of full support from the network.

NOTE 2 – The following Figure does not imply any hypothetical reference model (HRM).



**Figure 1 – Time distribution to timeReceiver clocks**

Additional aspects related to performance are also covered in [ITU-T G.8271] and [ITU-T G.8271.1].

## 7.2 Time/phase protection aspects

Protection is required to optimize the performance of the services. Protection is defined as the mechanisms that allow maintaining the phase/time reference delivered to the end application (e.g., a base station) to an acceptable level during failure events. It includes redundancy of the phase/time primary reference sources (time-plane rearrangement) and phase/time holdover (time-plane holdover). Protection is described in the following clauses in terms of protection of the pTT /PRTC and protection of the pTR.

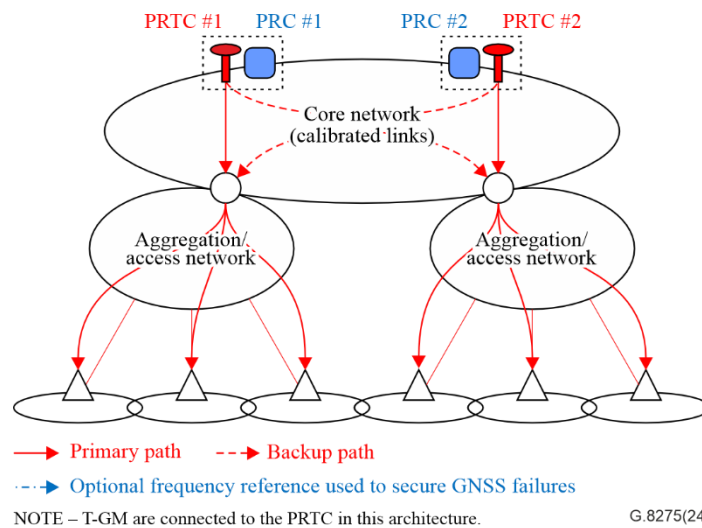
### 7.2.1 Packet timeTransmitter (pTT) protection

#### PRTC location

When considering phase/time distribution, the PRTC functions can be located at different positions, depending on the overall architecture that the network operator wishes to follow. However, these can be summarized into the four generic locations described in this clause.

These are the main scenarios; others may be considered.

*Case A: centralized PRTC collocated with a primary reference clock (PRC)*



**Figure 2 – Architecture with centralized PRTC functions collocated with the PRC**



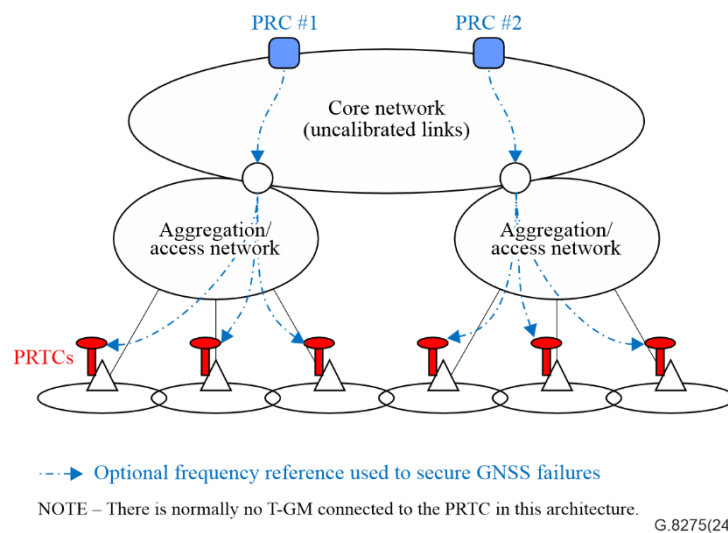
In this architecture, shown in Figure 4, the PRTC function is located in an aggregation site; typically, a GNSS receiver is added to one of the last synchronization supply units (SSUs) of the physical layer frequency chain. This implies the deployment of a higher number of GNSS receivers than in the centralized PRTC architecture. However, the advantage is that the links of the core network do not have to be calibrated to compensate for the link asymmetry.

PRTC redundancy schemes require connectivity between these aggregation sites; this may not always be possible. Control of the precision time protocol (PTP) hierarchy (e.g., to limit the segment of a network that can be synchronized by a specific PRTC) should be guaranteed by the proper setting of PTP parameters (e.g., `timeTransmitterOnly`, `notTimeTransmitter`).

When the PRTC redundancy is considered between different aggregation sites, it implies that some nodes of the core network would support PTP clocks (e.g., T-BC to be supported by the nodes between the PRTC functions), as well as proper calibration of some of the links of the core network.

When the PRTC redundancy is not used, it is recommended that GNSS failures be secured by other means; typically, the use of a PRC-traceable physical layer frequency reference delivered to the PRTC function allows extending the phase/time holdover period during the GNSS failures.

*Case D: distributed PRTC at the cell sites*



**Figure 5a – Architecture with PRTC functions distributed at the cell sites**

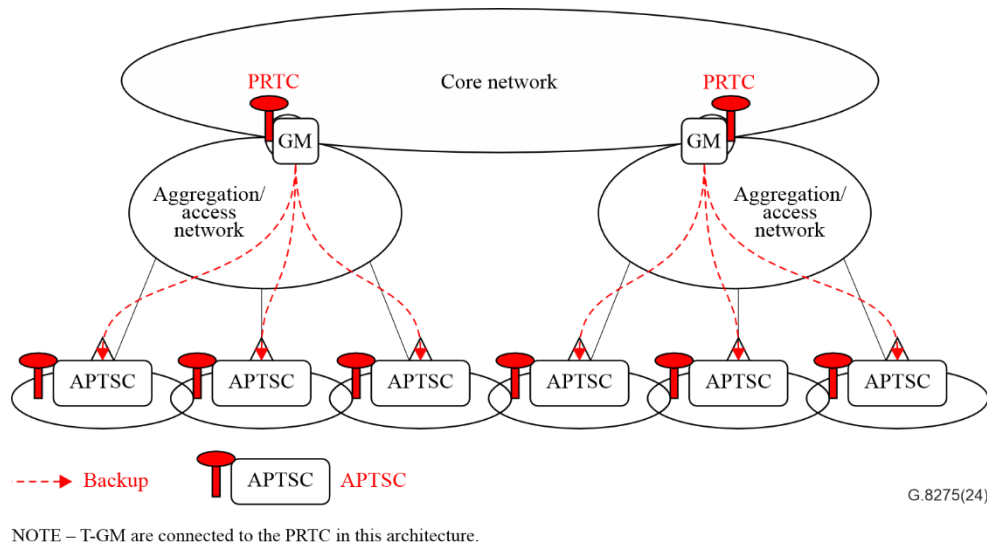
In this architecture, shown in Figure 5a, the PRTC function is now located directly at the cell site; typically, a GNSS receiver is directly connected to the base stations. This implies the deployment of a higher number of GNSS receivers than in the "centralized PRTC" and "distributed PRTC in an aggregation site" architecture. However, the advantage is that the links of both the core and the backhaul networks do not have to be calibrated to compensate for the link asymmetry.

PRTC redundancy schemes with this architecture require connectivity between different cell sites. Control of the PTP hierarchy (e.g., to limit the sites synchronized by a specific PRTC) should be guaranteed by a proper setting of the PTP parameters (e.g., `timeTransmitterOnly`, `notTimeTransmitter`).

If these connections are not possible, GNSS failures could be secured by other means; typically, the use of a PRC-traceable physical layer frequency reference delivered to the PRTC function allows extending the phase/time holdover period during the GNSS failures.

A combination of T-BC case C and case D is a possible option to minimize the number of GNSS receivers deployed at cell sites, and to provide further PRTC redundancy options.

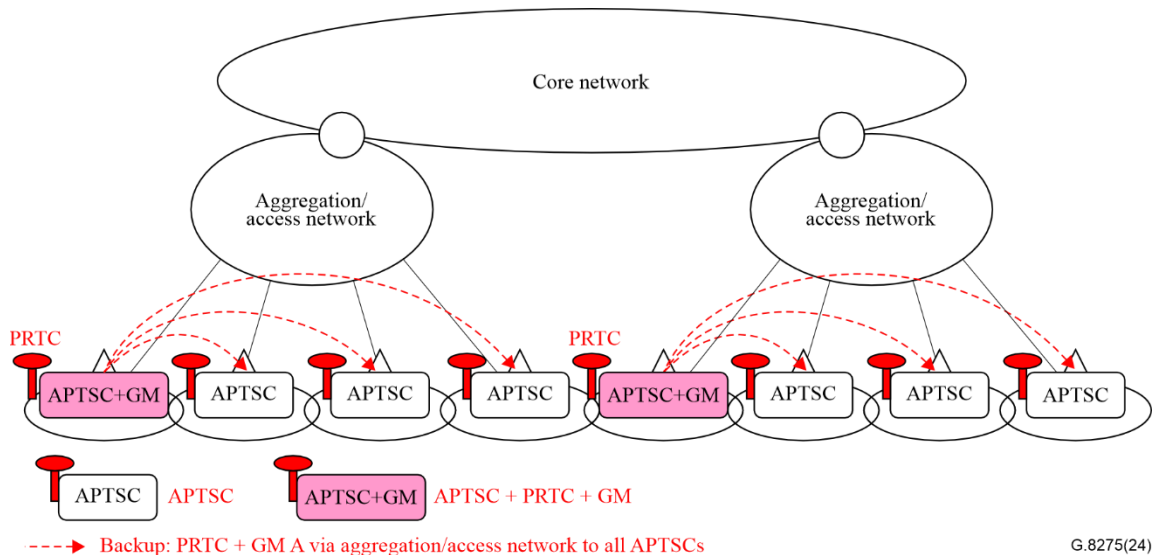
Case E: APTSC at the cell sites with distributed PRTC + GM protection in the aggregation sites



**Figure 5b – APTS architecture with PRTC functions distributed in the aggregation sites**

In this architecture, shown in Figure 5b, the assisted partial timing support clock (APTSC) function is located directly at the cell site; in addition, PRTC + GMs are located at the aggregation sites and distribute PTP streams to the APTSCs. These PTP streams are used by the APTSC in case of a PRTC/GNSS outage. This architecture implies deployment of a higher number of GNSS receivers than in the "centralized PRTC" architectures. However, PTP unaware or partially aware networks can be kept as short as possible to decrease the asymmetry and packet delay variation (PDV) introduced by the network.

Case F: APTSC at the cell sites with distributed PRTC protection at the cell sites

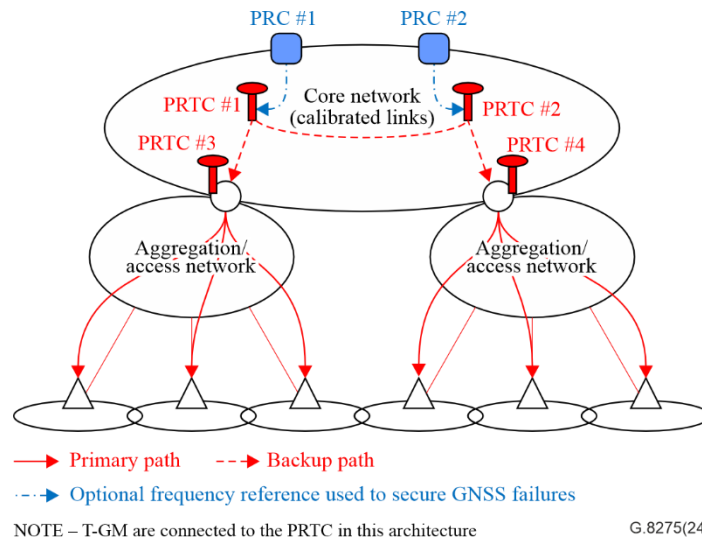


**Figure 5c – APTS architecture with PRTC+GM functions distributed at the cell sites**

In this architecture, shown in Figure 5c, the APTSC function is located directly at the cell site; in addition, grandmasters (GMs) are located at selected cell sites and distribute PTP streams to the adjacent APTSCs. These PTP streams are used by the APTSC in case of a PRTC/GNSS outage. This architecture implies deployment of a higher number of GNSS receivers than in the "centralized PRTC" architectures. However, PTP unaware or partially aware networks can be kept as short as

possible to decrease the asymmetry and PDV introduced by the network. In addition, the Global Navigation Satellite System (GNSS) signal available to the APTSC in the cell site is used by the collocated GM.

*Case G: centralized PRTC at the core network and distributed PRTC in aggregation sites*



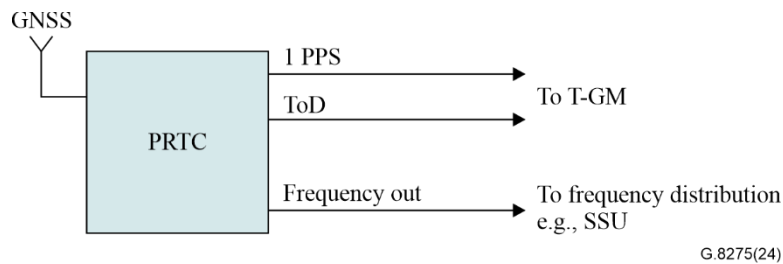
**Figure 5d – Centralized PRTC at the core network and distributed PRTC in the aggregation sites**

In this architecture, shown in Figure 5d, the PRTC is deployed at the core layer and the aggregation site. In the normal operation, the nodes of the backhaul network selects the PRTC at the aggregation as its primary reference. When the aggregation PRTC fails, one possibility is that the nodes of the backhaul network selects the PRTC at the core network as a backup; other options are also possible. This architecture deployment can be achieved via some parameter configurations, e.g., the priority2 or localPriority parameters.

In addition, if network timing isolation is required, e.g., the timing topology of two aggregation/access networks of Figure 5d need to be separated, the PTP port parameters (i.e., timeTransmitterOnly, notTimeReceiver) could be useful.

**Applicable PRTC models depending on the PRTC location**

The first PRTC model, illustrated in Figure 6, where no physical layer frequency input is present, may be applicable to case A introduced earlier. It corresponds to the case where PRTC and PRC functions are merged in the same equipment, and coherency between the frequency and phase/time planes is therefore ensured.

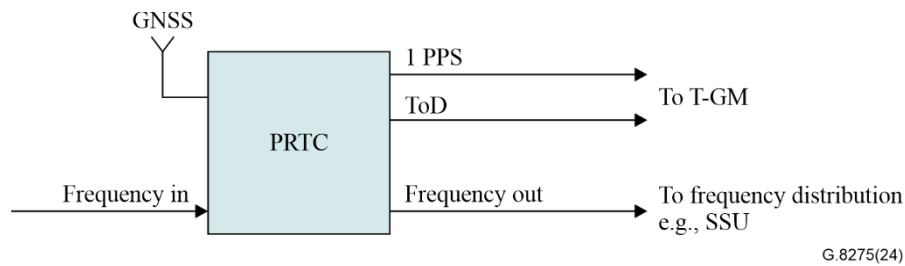


**Figure 6 – PRTC model with no physical layer frequency input**

NOTE – In addition to being connected to a T-GM, a PRTC may be connected to a T-BC by the 1 pulse per second (PPS) + time of day (ToD) interface. This is useful for some applications such as achieving protection in a ring network, see Appendix II.



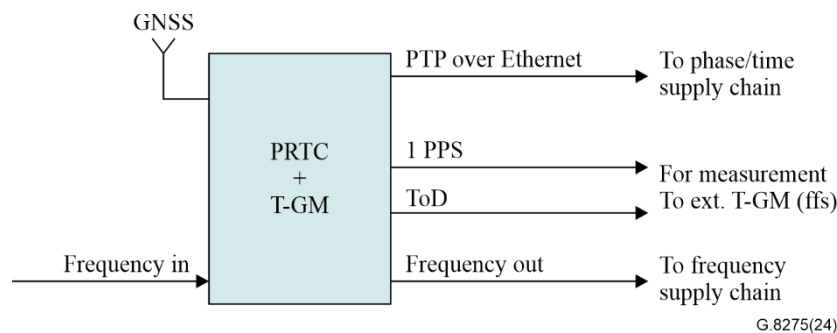
The second PRTC model, illustrated in Figure 7, where a physical layer frequency input is present and may be applicable to cases A, B, C, and D introduced earlier. It corresponds to the case where PRTC and PRC functions are implemented in separate equipment and coherency between the frequency, and phase/time planes is not always ensured.



**Figure 7 – PRTC model with a physical layer frequency input**

NOTE – In addition to being connected to a T-GM, a PRTC may be connected to a T-BC by the 1 PPS+ToD interface. This is useful for some applications such as achieving protection in a ring network, see Appendix II.

The case where the PRTC and T-GM are combined is shown in Figure 8. The Ethernet interface that supplies PTP may also supply frequency (i.e., it operates as a synchronous Ethernet interface).



**Figure 8 – Combined PRTC and T-GM**

There are other network architectures under study based on an enhanced PRTC (ePRTC) that provide the ability to maintain network-wide time accuracy (see Appendix VI). Additional details are for further study.

### 7.2.2 Packet timeReceiver (pTR) protection

This clause deals with the various schemes that may be considered for providing redundancy in the distribution of a time synchronization reference.

Three protection scenarios for phase/time synchronization of the pTR are described. The scenarios are:

- 1) phase/time long-term holdover with a physical layer frequency synchronization support;
- 2) switching to a backup reference with a physical layer frequency synchronization support;
- 3) switching to a backup reference without a physical layer frequency synchronization support.

Protection scenarios 2 and 3 involve time-plane rearrangements, while protection scenario 1 involves time-plane holdover. In protection scenario 2, the frequency reference during the rearrangement is provided via physical layer support, i.e., synchronous Ethernet. In protection scenario 3, the frequency reference during the rearrangement is provided via the end application clock in holdover. In protection scenario 1, the phase/time holdover is provided by a physical layer support.

The three scenarios are described in the following clauses.

### 7.2.2.1 Protection scenario 1

Protection scenario 1 involves holdover with a physical layer frequency support (i.e., synchronous Ethernet), where the period of holdover is generally much longer than the period of the rearrangement of protection scenario 2 (see clause 7.2.2.2). Three sub-scenarios may be considered for protection scenario 1. It is assumed that there is no backup timeTransmitter (TT) in this case:

- 1) scenario 1.1: The synchronous Ethernet reference used during the holdover is available at the end application;
- 2) scenario 1.2: The synchronous Ethernet reference used during the holdover is available at the PRTC, and it is the PRTC that enters the holdover by losing its GNSS reference. The end application receives its timing from the PRTC via PTP;
- 3) scenario 1.3: The synchronous Ethernet reference used during the holdover is available at the PRTC, and it is the PRTC that enters holdover by losing its GNSS reference. The end application is collocated with and receives its timing directly from the PRTC.

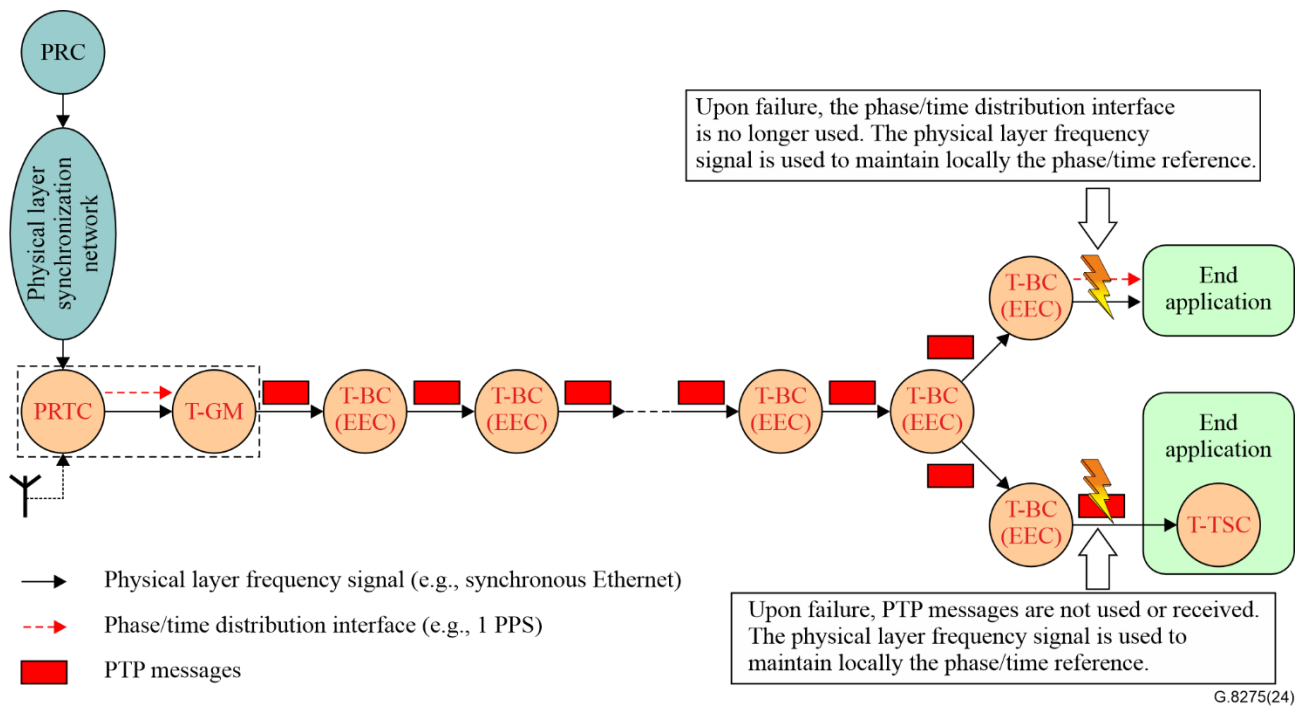
Three holdover periods are of interest for protection scenarios 1.1, 1.2 and 1.3:

- 1) short holdover period, on the order of minutes (e.g., up to 5 minutes, maximum);
- 2) long holdover period, on the order of hours (e.g., up to 8 hours);
- 3) very long holdover periods, on the order of days (e.g., up to 3 days).

The short holdover period is assumed to cover cases where the GNSS signals become unavailable for a short period of time. The long holdover period is assumed to cover cases where the GNSS signals remain unavailable for a longer period of time, possibly without the need for an on-site operator intervention. The very long holdover period covers the cases of very long failures, for which an on-site operator intervention is necessary.

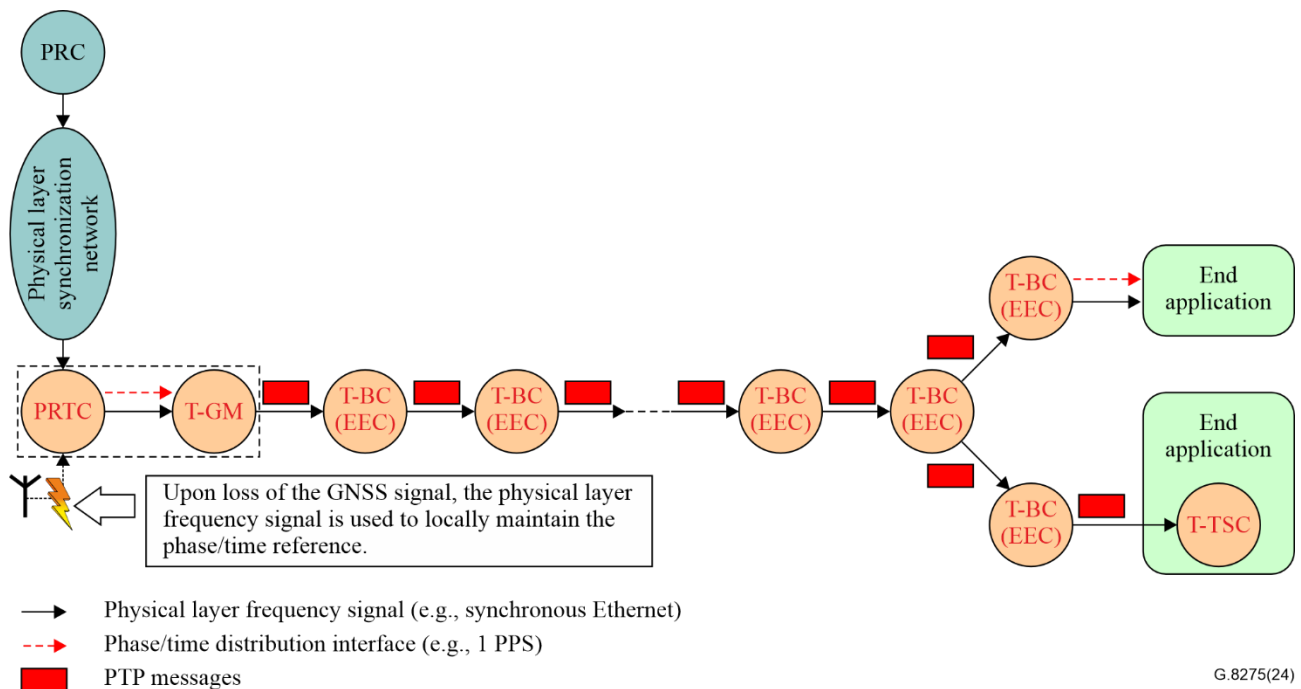
Protection scenario 1.1 is illustrated in Figure 9. In this protection scenario, the phase/time synchronization path fails and the end application (e.g., the base station) is informed that the reference signal is no longer traceable to a PRTC so that it would switch to the holdover. Relying on only a free-running local clock, even of good quality, may not allow addressing the long and very long holdover periods mentioned above. Instead, the local clock in the end application must be locked to an accurate and stable physical layer frequency reference, such as the synchronous Ethernet.

The phase/time long-term holdover function is assumed to be supported in a PTP clock capable of adequately filtering the noise that may be present on the synchronous Ethernet reference. The same function can be used in a base station receiving both a 1 PPS input signal and a synchronous Ethernet reference. During the holdover period, any timing signal delivered to the application by PTP is not used.



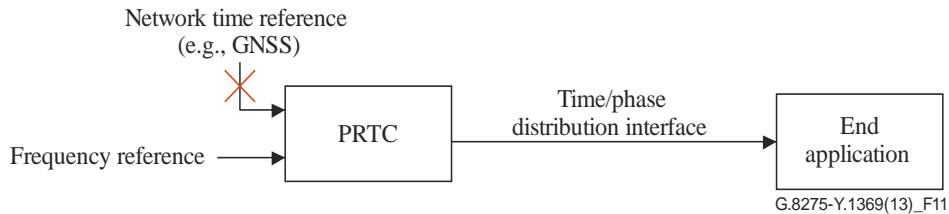
**Figure 9 – Illustration of protection scenario 1.1 at the T-TSC (phase/time long-term holdover at the T-TSC embedded in the end application)**

Protection scenario 1.2 is illustrated in Figure 10. In this case, the phase/time long-term holdover function is supported by the PRTC/T-GM. Like protection scenario 1.1, this holdover function includes a clock that is capable of providing a high-quality frequency reference (e.g., high quality local oscillator or a synchronous Ethernet equipment clock (EEC)). When the PRTC connected to the T-GM has lost its reference (e.g., GNSS signal is lost), the PRTC may continue to deliver time synchronization using this frequency reference.



**Figure 10 – Illustration of protection scenario 1.2 at the PRTC/GM, (phase/time long-term holdover at the PRTC/GM, with the PRTC/GM not collocated with the end application)**

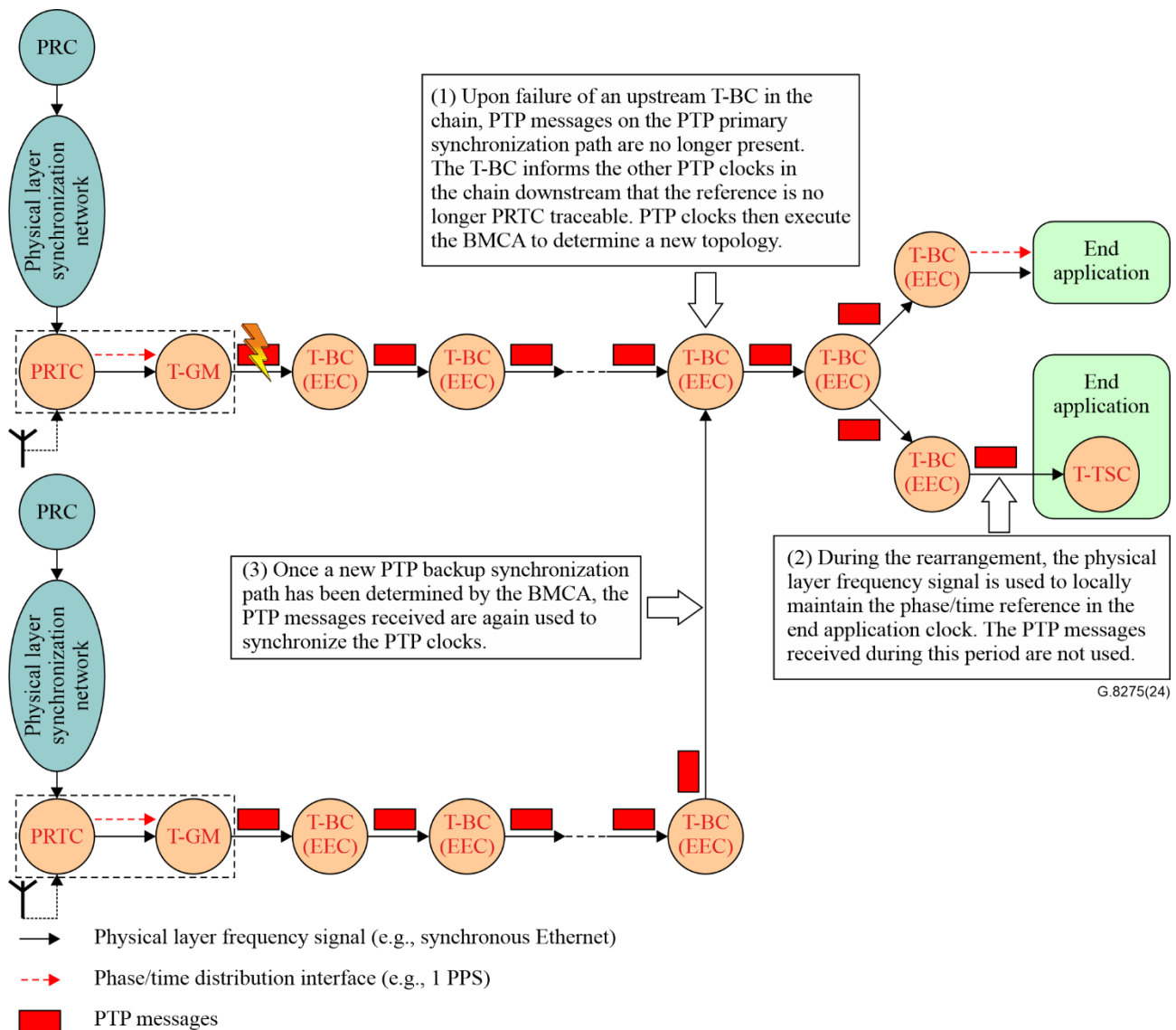
Protection scenario 1.3 is illustrated in Figure 11. In this case, as in protection scenario 1.2, the phase/time long-term holdover function is supported by the PRTC, which is also assumed to have a good oscillator embedded, for instance, in case of problems with the GNSS signals reception. When the PRTC has lost its reference (e.g., GNSS signal is lost), the PRTC may continue to deliver time synchronization either using the internal oscillator or an external frequency synchronization reference (e.g., synchronous Ethernet). However, now the PRTC is collocated with the end application.



**Figure 11 – Illustration of protection scenario 1.3 at the PRTC (phase/time long-term holdover at the PRTC, with the PRTC collocated with the end application)**

### 7.2.2.2 Protection scenario 2

Protection scenario 2 is illustrated in Figure 12. In this protection scenario, a telecom boundary clock (T-BC) in the chain detects a failure in the primary PTP phase/time synchronization path, e.g., it stops receiving PTP time-stamp messages on its timeReceiver port, or the information on the signal indicates a degraded reference. This T-BC informs the downstream PTP clocks (T-BC, T-TSC) that the reference is no longer traceable to a PRTC. This triggers the best timeTransmitter clock algorithm (BTCA) and a new PTP path is determined.



**Figure 12 – Illustration of protection scenario 2 (switching to a backup reference with physical layer frequency synchronization support)**

Immediately after the failure has been detected, the end application (e.g., a base station) is therefore informed that the reference signal is no longer traceable to a primary reference time clock (PRTC) and switches to the holdover. It may take some time to propagate this information down the chain, depending on the position of the T-BC which has detected the failure. The local clock in the end application is locked to an accurate and stable physical layer frequency reference, such as the synchronous Ethernet, since this support is used.

The BTCA is run to determine a new PTP synchronization path.

The phase/time holdover function is assumed to be supported in the T-TSC embedded in the base station. The same function can be used in a base station receiving both a 1 PPS input signal and a synchronous Ethernet reference (in this case, the 1 PPS signal should be squelched during the failure).

The T-BC must be able to inform about the loss of the PRTC traceability.

### 7.2.2.3 Protection scenario 3

Protection scenario 3 is illustrated in Figure 13. In this protection scenario, a T-BC in the chain detects a failure in the primary PTP phase/time synchronization path, e.g., it stops receiving PTP time-stamp messages on its timeReceiver port, or the information on the signal indicates a degraded reference.



## **8 Security aspects**

Unlike traditional timing streams where frequency is carried over the physical layer, packet-based timing streams may be observed at different points in the network. There may be cases where timing packets flow across multiple network domains which may introduce specific security requirements. There may also be aspects of security that may be related to both the network (e.g., authentication and/or authorization) and to the PTP protocol itself.

It is important to permit the operation with existing standards-based security techniques to help ensure the integrity of the synchronization. Examples may include encryption and/or authentication techniques, or network techniques for separating traffic, such as virtual local area networks (VLANs) or label-switched paths (LSPs).

It may not be possible to implement some of these requirements without actually degrading the overall level of timing or the system performance.

Certain aspects of security are for further study; however, some critical aspects are:

- timeReceivers should be prevented from connecting to rogue timeTransmitters (this could be either by an authentication process or by using a network separation to prevent rogue timeTransmitters from accessing the timeReceivers);
- a T-BC port that is connected to a "customer" must never enter the TIME\_RECEIVER (TR) state;
- timeTransmitters should be prevented from providing services to unauthorised timeReceivers.

## **9 Management aspects**

Network management aspects are for further study.

## Annex A

### Time/phase models based on ITU-T G.805

(This annex forms an integral part of this Recommendation.)

[ITU-T G.8264] provides descriptions of timing flows related to packet network synchronization. Specifically, timing flows are shown which cover the case of the circuit emulation and physical layer frequency synchronization based on the synchronous Ethernet.

This annex shows the timing flows appropriate to packet-based time mechanisms.

Network models help to ensure that interoperable systems can be developed. What follows is a discussion of [ITU-T G.805] as a modelling technique, as this is what was used in the initial development of [ITU-T G.8264]. [ITU-T G.805] has been used for many years to describe the behaviour of the time-division multiplexing (TDM) systems. Since the development of [ITU-T G.8264], further work has been undertaken within ITU-T to extend the models to cover packet networks. However, for the purposes here, it is sufficient to refer to the [ITU-T G.805] models.

[ITU-T G.805] provides the modelling "language" to describe transport networks and it describes at the high level, the functional blocks that form a transport network. These define the overall "architecture" in a manner that is implementation independent. A key aspect of the architecture is the concept of network layers. Typically, networks are managed on a per-layer basis, and interactions between the layers follow client / server relationships. For telecom applications, OAM is defined on a per-layer basis.

For a modelling construct such as [ITU-T G.805], a key aspect of the model is that there are well-defined interactions between the functions. Common constructs in [ITU-T G.805] models include trails (which support the end-to-end transfer of information and the various adaptation, termination, and connection functions). The newer ITU-T, models to define packet networks describe "flows". The work in [ITU-T G.8264] had anticipated this and thus it describes the timing flows.

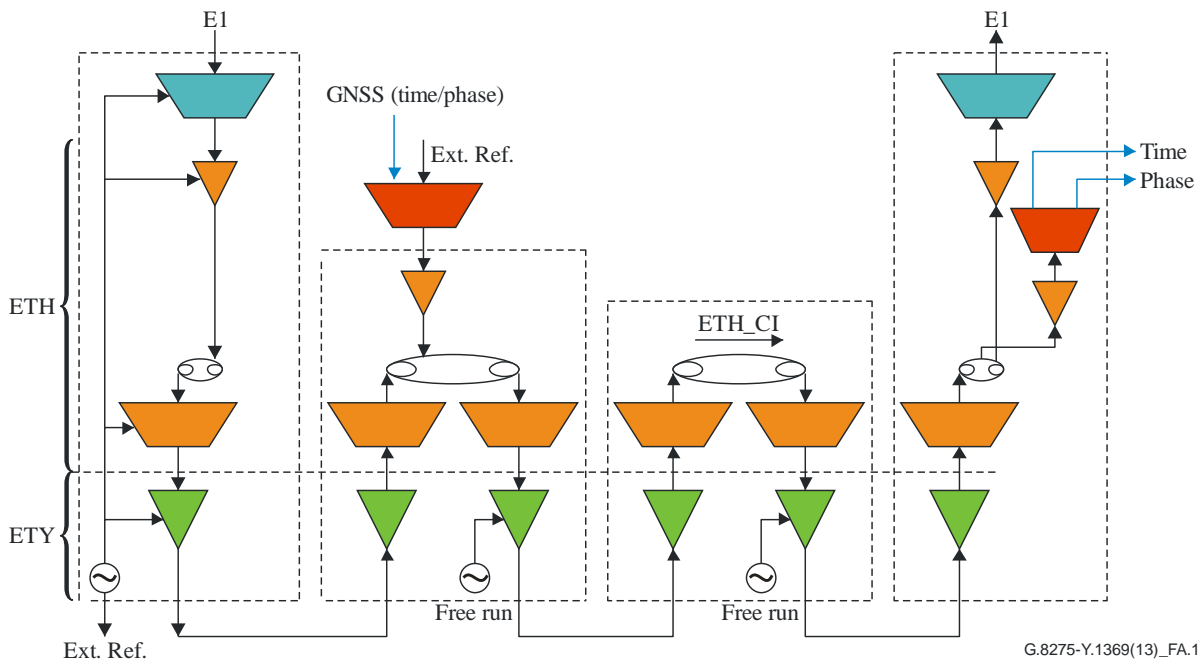
The major benefit of the architectural modelling is that if properly specified and followed, functional interactions are fully understood from the network level and therefore a complete specification of the equipment consistent with the capabilities of the network is possible. Additionally, this results in a network that has a high level of interoperability and is fully manageable.

#### The model to support time/phase

Extension of the [ITU-T G.8264] models to cover time/phase becomes conceptually straightforward and is shown in Figure A.1. Here the output of the adaptation function is time/phase. The format of time/phase is not considered at this point. The important aspects are that the input to the source adaptation function must have additional information (time/phase), rather than simply being a frequency reference. The information that is carried across the network remains, from the network perspective, the same as in the frequency only case. The network carries the PTP packets. The adaptation functions would be responsible for producing the appropriate outputs. This only shows the timing path and traverses multiple packet network elements. This is illustrative of the model only.

In the case where frequency output is also required, this could be via the adaptation function. For simplicity, this is not shown in the Figure, but it could be described (i.e., an additional frequency output could be provided).

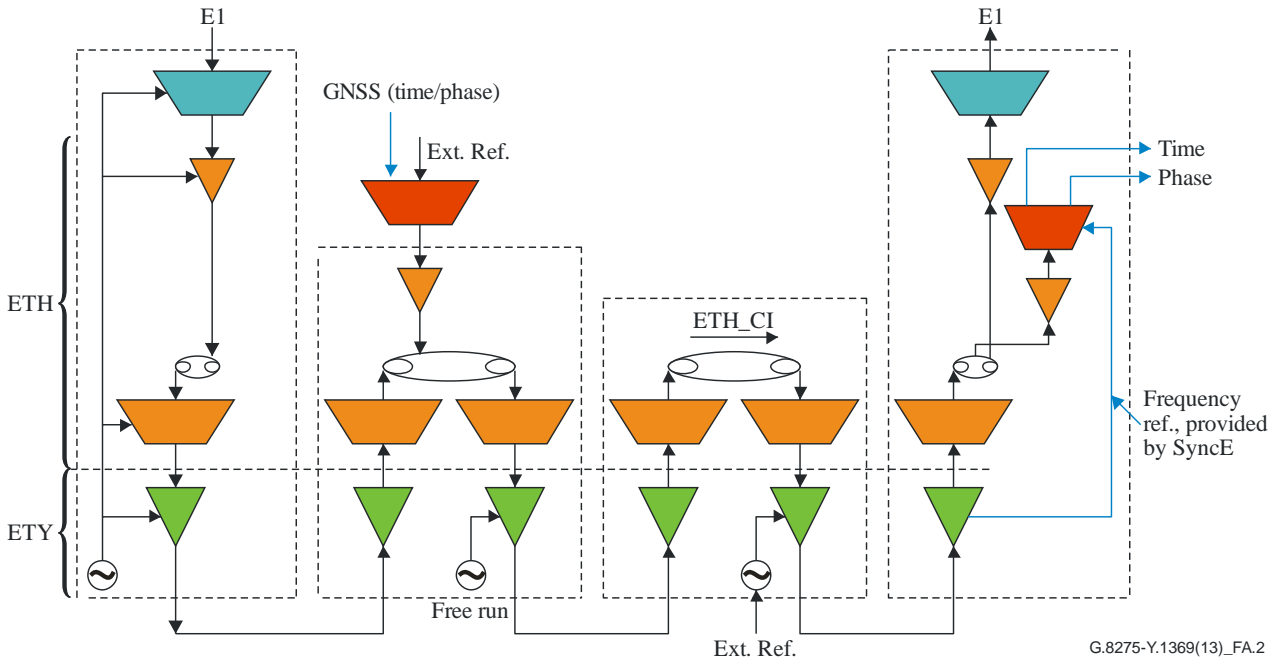




**Figure A.1 – Extension of basic [ITU-T G.8264] model to support time/phase**

**Packet time/phase with frequency support by the network**

Figure A.2 shows how time/phase can be assisted with the frequency. In this specific example, the frequency reference is provided via a synchronous Ethernet. A similar model could be developed where the input is via an external interface. This model begins to illustrate the independence of time/phase with frequency.



**Figure A.2 – Time/phase with frequency support provided by the network (e.g., synchronous Ethernet)**

## Annex B

### Inclusion of a virtual PTP port on a PTP clock

(This annex forms an integral part of this Recommendation.)

This annex describes the model for inclusion of a unidirectional, phase/time interface on a precision time protocol (PTP) clock. High-level principles are introduced in this annex.

This interface will be referred to as a virtual PTP port. This virtual PTP port may be used to model:

- An external input signal of the clock (e.g., coming from a PRTC, such as 1 PPS + ToD);
- An external output signal of the clock (e.g., going to an end application, such as 1 PPS + ToD);
- An internal input (i.e., an input that originates within the node and is not accessible externally) to a PTP clock that is coming from a source outside of the PTP clock's domain;
- An internal output (i.e., an output that originates within the node and is not accessible externally) of a PTP clock that is going to a sink outside of the PTP clock's domain.

When associated with an input signal, a virtual PTP port allows this interface to participate in the PTP protocol. As an input, this port can participate in the source selection with an associated virtual  $E_{r_{best}}$  or  $D_0$  using the associated virtual PTP port. As an input, the virtual PTP port may be used as part of the "interfaces enabling interdomain interactions" defined in clause 18 of [IEEE 1588-2019] and illustrated in Annex O of [IEEE 1588-2019], most applicably as the source adapter block providing meta-data.

When associated with an external output signal, a virtual PTP port allows the communication of the PTP clock information to other equipment.

Not all parameters supported by the virtual PTP port are required to be supported by the PTP clock. The parameters grouped as locally set are not transmitted across the virtual PTP port but are set internally by the receiver of the virtual PTP port information. The parameters supported by a virtual PTP port are listed below.

- Time properties data set (DS)
  - Leap61
  - Leap59
  - currentUtcOffsetValid
  - ptpTimescale
  - timeTraceable
  - frequencyTraceable
  - timeSource
  - currentUtcOffset
- Parent data set
  - grandmasterIdentity
  - grandmasterClockQuality
    - clockClass
    - clockAccuracy
    - offsetScaledLogVariance
  - grandmasterPriority1
  - grandmasterPriority2

- Other parameters
  - stepsRemoved
  - versionPTP
  - domainNumber
  - Time of day (ToD)
- Locally set
  - Signal fail (SF)
  - localPriority
  - portNumber

NOTE 1 – The stepsRemoved attribute is set to zero in the case where a PRTC is connected to a virtual PTP input port.

NOTE 2 – The SF is a locally set property of the PTP port. Signal fail is set to TRUE when the PTP clock determines the input virtual PTP port (e.g., 1 PPS, GNSS) is not useable. When SF is TRUE the portDS.SF parameter is set to TRUE.

NOTE 3 – When the external input virtual PTP port is a local external physical clock source, such as the GNSS, the grandmasterIdentity assigned to the input virtual PTP port is the clockIdentity of the PTP clock itself.

NOTE 4 – The portNumber assigned to the virtual PTP port is set to a value different from the portNumber values already assigned to the other PTP ports of the PTP clock.

## Annex C

### Options to establish the PTP topology with the alternate BTCA

(This annex forms an integral part of this Recommendation.)

For the ITU-T PTP telecom profiles [ITU-T G.8275.1] and [ITU-T G.8275.2] which include a localPriority attribute, the alternate best timeTransmitter clock algorithm (BTCA) of those profiles allows two main approaches to set up the topology of the phase/time synchronization network:

- Automatic topology establishment: When configuring the localPriority attributes to their default value, the PTP topology is established automatically by the alternate BTCA based on the *Announce* messages exchanged by the PTP clocks. A synchronization tree with the shortest paths to the T-GMs is built after this operation. In this mode, during failure events and topology reconfiguration, the alternate BTCA will be run again and result in a new synchronization tree. This alternate BTCA operation ensures that no timing loop will be created without requiring manual intervention or prior analysis of the network. The convergence time to the new PTP topology depends on the size of the network, and on the specific configuration of the PTP parameters.
- Manual network planning: The use of the localPriority attributes with different values than their default value allows building manually the synchronization network topology, in a similar way as synchronous digital hierarchy (SDH) networks are typically operated based on the synchronization status message (SSM). This option allows full control on the actions during failure events and topology reconfiguration, based on the configured local priorities of the system. However, careful network planning is required prior to the deployment in order to avoid timing loops.

## Annex D

### **Synchronization uncertain indication (optional)**

(This annex forms an integral part of this Recommendation.)

This annex is used in the ITU-T PTP telecom profiles [ITU-T G.8275.1] and [ITU-T G.8275.2]. It is optional, but if implemented, it is necessary for the equipment to conform to the requirements contained herein. When a PTP clock selects a new parent as a synchronization time source, the PTP port associated with that new parent is placed in the UNCALIBRATED state. This PTP port state indicates that the PTP clock is in the process of synchronizing to the time source. The duration and functionality of this state is implementation specific. During this period, the PTP clock may have large or fast changes in frequency and phase, and while it is desirable that the updated parent information be propagated downstream to allow the topology to settle, it may not be desirable for the downstream PTP clocks to use the timing information. Therefore, communicating to downstream PTP clocks about the UNCALIBRATED state would be beneficial.

The local synchronizationUncertain Boolean, used with Announce messages transmitted from an egress port is FALSE except under the following conditions for which it shall be TRUE:

- the synchronizationUncertain flag of the Announce message received from the parent clock is TRUE; or
- the ingress port is in the UNCALIBRATED state; or
- implementation specific criteria.

When the synchronizationUncertain condition is TRUE then in the transmitted Announce message, the flagField – octet 1, bit 6 is set to 1. Otherwise, when the synchronizationUncertain condition is FALSE, the bit is set to 0.

The default value for the synchronizationUncertain flag was picked so that the value transmitted out of a PTP clock that does not have the synchronizationUncertain functionality indicates that its timing information can be used. This allows a downstream clock that does support the functionality to use an upstream parent clock that does not support this functionality. The downstream clock considers the timing information from the upstream clock as usable and performs synchronization processing using this timing information. As this situation can lead to the misinterpretation of the actual synchronization quality at the end of the network clock chain, it is not recommended to depend on this synchronizationUncertain indication unless all the PTP clocks in the network support this functionality.

## Annex E

### Use of the `timeTransmitterOnly` and not `TimeTransmitter` parameters in the networks

(This annex forms an integral part of this Recommendation.)

There are two `portDS` members that may be used to control the network topology – `portDS.timeTransmitterOnly` and `portDS.notTimeTransmitter`.

The `portDS.timeTransmitterOnly` operation is specified in clause 9.2.2.2 of [IEEE 1588-2019]. This applies to the implementations of this profile based on [IEEE 1588-2008] and those based on [IEEE 1588-2019]. For a telecom boundary clock (T-BC), the ports for which the `timeTransmitterOnly` attribute is `FALSE` it is allowed to enter into the `TIME_RECEIVER` state and therefore may be used to receive timing into the T-BC. The use of the `timeTransmitterOnly` is intended primarily to be used in the following scenarios:

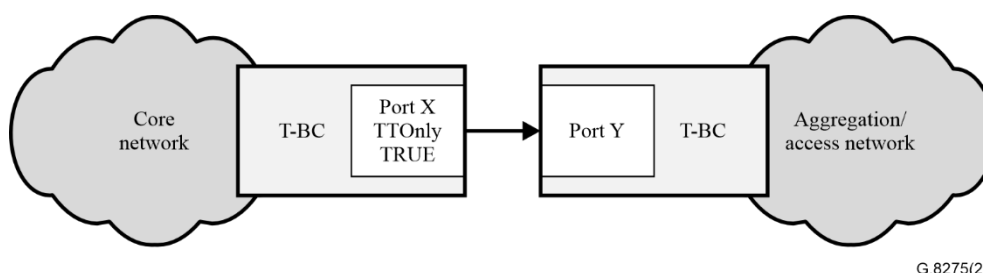
- A PTP port of a T-GM.
- A PTP port of a T-BC that is facing the 'downstream' direction towards the access portion of a tree hierarchy.
- A PTP port of a T-BC that is facing an end application. Note that if an end application includes a `timeReceiverOnly` ordinary clock, then by definition, it will not send Announce messages.

The use of the `timeTransmitterOnly` (TTOOnly) parameter in other scenarios, such as on PTP ports participating in a ring architecture, may result in an unintended operation, especially during re-configuration or topology changes.

One typical use case where this parameter should remain `TRUE` is the prevention of timing propagating from the access portion of the network to the core portion of the network as shown in Figure E.1.

This may also be applicable at a user network interface (UNI) or a network node interface (NNI) between the two operators where the flow of synchronization is known.

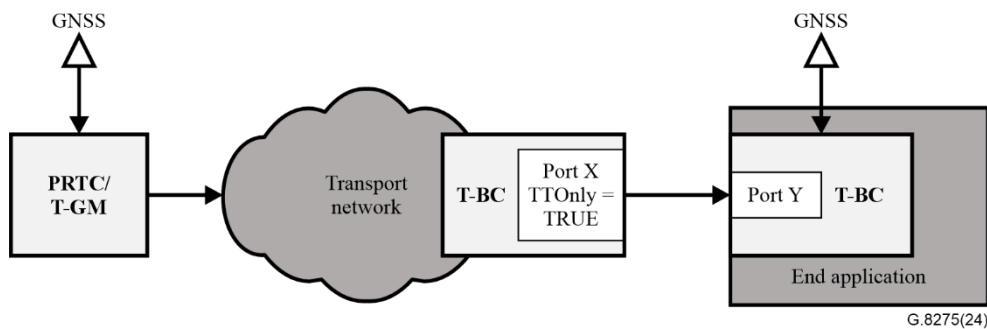
In addition, this may also be applicable for an inter-working function (IWF) where the direction of the timing is known in advance, or similarly for uni-directional timing flows through the native access equipment.



**Figure E.1 – PTP timing propagation from core to access**

Another typical use case where this parameter should remain `TRUE` is where:

- a) there is a need to prevent timing from propagating from the end application to the transport network, and
- b) the PTP clock in the end application is not a `timeReceiverOnly` clock, as shown in Figure E.2.

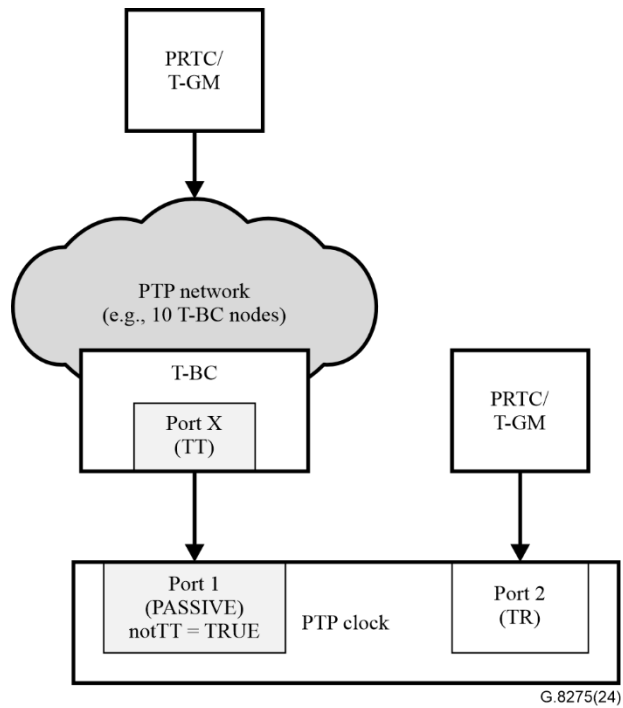


**Figure E.2 – PTP timing propagation from the transport network to the end application**

The `portDS.notTimeTransmitter` is in some measure the opposite effect of the `portDS.timeTransmitterOnly`. If `notTimeTransmitter` is `TRUE`, the port is never placed in the `PRE_TIME_TRANSMITTER` or `TIME_TRANSMITTER` (TT) state, and, if the recommended state by the alternate BTCA is `BTC_TIME_TRANSMITTER`, then the PTP port should instead be placed in the `PASSIVE` state. The `notTimeTransmitter` attribute does not affect the state of the PTP port if the recommended state is `BTC_TIME_RECEIVER` or `BTC_PASSIVE` (e.g., if `notTimeTransmitter` is `TRUE` and the recommended state is `BTC_TIME_RECEIVER`, the PTP port will be placed in the `TIME_RECEIVER` state). The `notTimeTransmitter` attribute is set via `portDS.notTimeTransmitter`.

The `portDS.notTimeTransmitter` primarily gives control to an individual PTP clock itself to avoid the propagation of synchronization, and also indirectly provides the ability to monitor its peers.

One use case for the `notTimeTransmitter` attribute is for the PTP clocks located at the end of the clock chain where it is known in advance that their PTP ports will not be re-transmitting timing further downstream (such as a daisy chain). In the situation shown in Figure E.3, the PTP clock is located with a PRTC/T-GM connected to port 2, which is selected by the BTCA as the best source (perhaps due to the smallest `stepsRemoved` value) and is placed into the `TIME_RECEIVER` state. Ordinarily, that may result in port 1 of the PTP clock to be placed into the `TIME_TRANSMITTER` (TT) state and the upstream telecom boundary clock (T-BC) being placed into the `TIME_RECEIVER` state (e.g., perhaps due to the `stepsRemoved` comparison, in this case shown the `stepsRemoved` from the upper PRTC/T-GM via the PTP network is 10). That outcome would result in where the upper PTP network selects the timing from the lower PRTC/T-GM connecting to the PTP clock and prevent port 1 in the `TIME_TRANSMITTER` state of the PTP clock from monitoring the upper PTP network. However, if port 1 enables the `notTimeTransmitter` attribute, then instead Port 1 is placed into the `PASSIVE` state, and the peer PTP port X is placed into the `TIME_TRANSMITTER` state. As a result, it avoids the upper PTP network to select the lower PRTC/T-GM as its reference. Meanwhile, port 1 in the `PASSIVE` state can monitor the timing from the upper PTP network (see Annex G of [ITU-T G.8275.1]).



**Figure E.3 – PTP clock with notTimeTransmitter enabled**

This notTimeTransmitter attribute may also be useful for the inter-working function (IWF) where the direction of the timing is known in advance with multiple PTP ports, or similarly for uni-directional timing flows through the native access equipment.



## Annex F

### Performance monitoring (optional)

(This annex forms an integral part of this Recommendation.)

This annex is used in the ITU-T PTP telecom profiles [ITU-T G.8275.1] and [ITU-T G.8275.2]. It is optional, but if implemented, it is necessary for the equipment to conform to the requirements contained herein.

A T-BC, T-TSC, T-BC-P, T-BC-A, T-TSC-P or T-TSC-A implementing this option collects the performance monitoring data as listed in Table F.1.

This is based on Table J.1 from clause J.2 of [IEEE 1588-2019].

**Table F.1 – PTP instance performance monitoring parameters**

Parameter name	Definition	Data type
averageTT-TR-Delay	Average of the TT-TR-Delay for each 15 minute and 24 h interval.	TimeInterval
minTT-TR-Delay	Minimum of the TT-TR-Delay for each 15 minute and 24 h interval.	TimeInterval
maxTT-TR-Delay	Maximum of the TT-TR-Delay for each 15 minute and 24 h interval.	TimeInterval
stdDevTT-TR-Delay	StdDev of the TT-TR-Delay for each 15 minute and 24 h interval.	TimeInterval
averageTR-TT-Delay	Average of the TR-TT-Delay for each 15 minute and 24 h interval.	TimeInterval
minTR-TT-Delay	Minimum of the TR-TT-Delay for each 15 minute and 24 h interval.	TimeInterval
maxTR-TT-Delay	Maximum of the TR-TT-Delay for each 15 minute and 24 h interval.	TimeInterval
stdDevTR-TT-Delay	StdDev of the TR-TT-Delay for each 15 minute and 24 h interval.	TimeInterval
averageMeanPathDelay	Average of the <meanPathDelay> for each 15 minute and 24 h interval.	TimeInterval
minMeanPathDelay	Minimum of the <meanPathDelay> for each 15 minute and 24 h interval.	TimeInterval
maxMeanPathDelay	Maximum of the <meanPathDelay> for each 15 minute and 24 h interval.	TimeInterval
stdDevMeanPathDelay	StdDev of the <meanPathDelay> for each 15 minute and 24 h interval.	TimeInterval
averageOffsetFromTT (see Note 1)	Average of the <offsetFromTT> for each 15 minute and 24 h interval.	TimeInterval
minOffsetFromTT (see Note 1)	Minimum of the <offsetFromTT> for each 15 minute and 24 h interval.	TimeInterval

**Table F.1 – PTP instance performance monitoring parameters**

Parameter name	Definition	Data type
maxOffsetFromTT (see Note 1)	Maximum of the <offsetFromTT> for each 15 minute and 24 h interval.	TimeInterval
stdDevOffsetFromTT (see Note 1)	StdDev of the <offsetFromTT> for each 15 minute and 24 h interval.	TimeInterval

NOTE 1 – When the main usage of the statistics is to be compared against a threshold level crossing alarm, it might be more convenient to display an absolute value, for example, the observed abs (average offset from TimeTransmitter), instead of the related signed value. This is implementation specific.

A T-BC, T-TSC, T-BC-P, T-BC-A, T-TSC-P or T-TSC-A clock implementing this option collects the additional parameters as listed in Table F.2 below. The applicability of these parameters to T-TC is for further study.

These are based on Table J.3 from clause J.3 in [IEEE-1588-2019], excluding the following counters: pDelayReqTx, pDelayReqRx, pDelayRespTx, pDelayRespRx, pDelayRespFollowupTx, pDelayRespFollowupRx.

**Table F.2 – Additional parameters**

Parameter name	Definition	Data type
announceTx	Counter indicating the number of Announce messages that have been transmitted for each 15 minute and 24 h interval.	UInteger32
announceRx	Counter indicating the number of Announce messages from the current GM that have been received for each 15 minute and 24 h interval.	UInteger32
announceForeignTTRx	Counter indicating the total number of Announce messages from the foreign TimeTransmitter that have been received for each 15 minute and 24 h interval.	UInteger32
syncTx	Counter indicating the number of sync messages that have been transmitted for each 15 minute and 24 h interval.	UInteger32
syncRx	Counter indicating the number of sync messages that have been received for each 15 minute and 24 h interval.	UInteger32
followUpTx	Counter indicating the number of Follow_Up messages that have been transmitted for each 15 minute and 24 h interval.	UInteger32
followUpRx	Counter indicating the number of Follow_Up messages that have been received for each 15 minute and 24 h interval.	UInteger32
delayReqTx	Counter indicating the number of Delay_Req messages that have been transmitted for each 15 minute and 24 h interval.	UInteger32
delayReqRx	Counter indicating the number of Delay_Req messages that have been received for each 15 minute and 24 h interval.	UInteger32

**Table F.2 – Additional parameters**

<b>Parameter name</b>	<b>Definition</b>	<b>Data type</b>
delayRespTx	Counter indicating the number of Delay_Resp messages that have been transmitted for each 15 minute and 24 h interval.	UInteger32
delayRespRx	Counter indicating the number of Delay_Resp messages that have been received for each 15 minute and 24 h interval.	UInteger32

NOTE 2 – [IEEE 1588-2019] Table J.2 is not applicable to [ITU-T G.8275.1] and [ITU-T G.8275.2] because it deals with a peer-to-peer delay mechanism. Counters for signalling messages (related to unicast negotiation used by the [ITU-T G.8275.2] PTP telecom profile) are for further study.

Record data types are based on clause J.4 of [IEEE 1588-2019] and data sets for performance monitoring are specified in clause J.5 of [IEEE 1588-2019].

As per [IEEE 1588-2019] Annex J, data collection periodicity is with a single record every 15 minutes and a single record for the full period (24 hours). This is indicated as "Regular data storage" in clause F.1.1.

In addition, a second set of data collection ("Simplified data storage" as indicated in clause F.1.2) is based on a single record every 3 minutes and a single record for the full period of 1 hour. The related data sets specified in [IEEE 1588-2019] Annex J.5 should be adapted accordingly in this case.

Both sets of data collection (clauses F.1 and F.2) should be supported. An exemption is possible for smaller equipment to support one of them.

NOTE 3 – A PTP instance implementing [IEEE 1588-2019] Annex J is interoperable with an implementation supporting this Annex. The time-of-day clock used to build the record should be reliable and preferably based on a timing reference that is not impacted by the same type of failures that can impact the recovered PTP clock.

The collected data can be used by a network management system for monitoring analysis. As an example, when an assisted partial timing support (APTS) is used, it could provide information on the network asymmetry. As a second example, sudden change in the value of some of the parameters, such as maxMeanPathDelay, can indicate that there has been network rearrangements in a specific link. By having information on the synchronization network topology, it should be possible to identify the end applications that may be impacted by these changes and perform further analysis if needed.

## **F.1 Data storage**

Two options apply for the data storage as specified in clauses F.1.1 and F.1.2 respectively.

### **F.1.1 Regular data storage:**

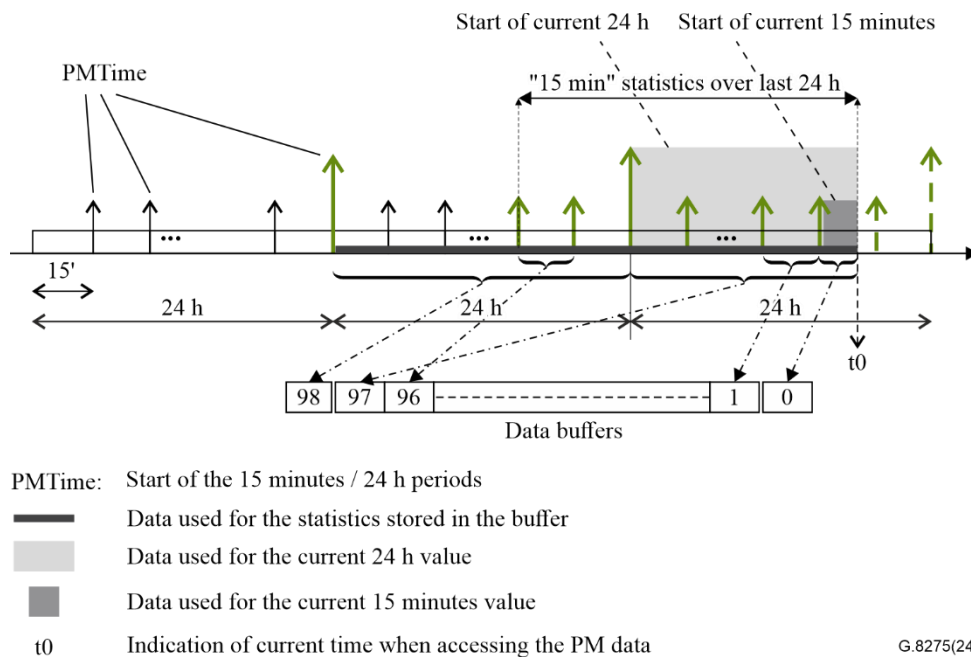
Data is stored over the past 24 hours.

This results in a list of records as defined in [IEEE 1588-2019] Annex J.4, composed by:

96 for the 15-minute sets of statistics, plus the current values; 1 x 24-hours sets of statistics, plus the current value.

This results in 99 sets of values in total.

The data buffers are numbered between 0 and 98 as shown in the following Figure F.1.



**Figure F.1 – Performance monitoring data collection for the regular data storage**

### F.1.2 Simplified data storage:

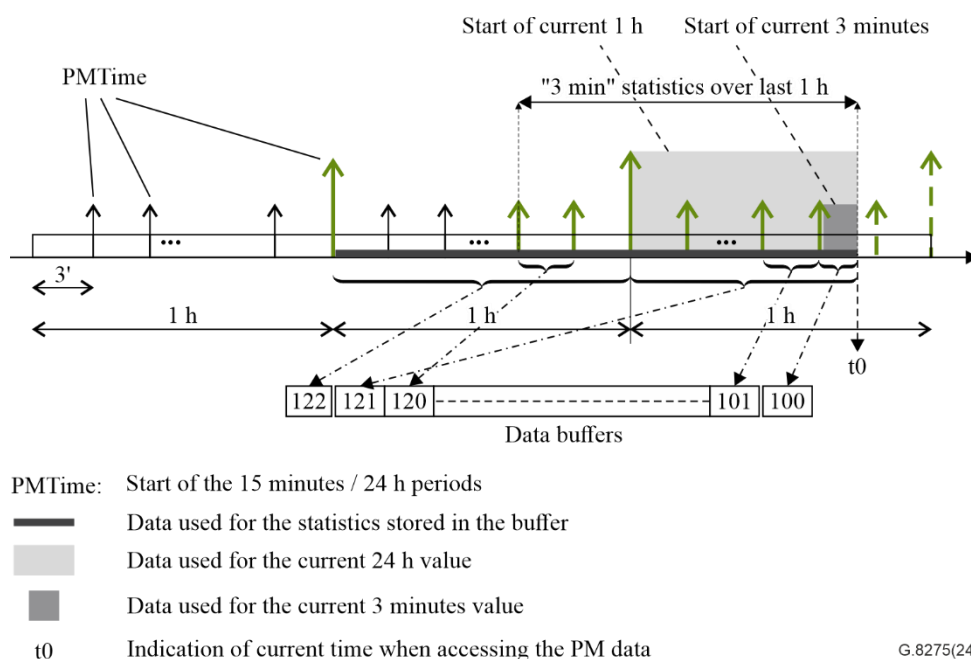
Data is stored over the past 1 hour.

This results in a list of records as defined in [IEEE 1588-2019] Annex J.4 and adapted to the 3 minutes granularity and 1 hour period, composed by:

20 for the 3-minute sets of statistics, plus the current values; 1 × 1-hour sets of statistics, plus the current value.

This results in 23 sets of values in total.

The data buffers are numbered between 100 and 122 as shown in the following Figure F.2.



**Figure F.2 – Performance monitoring data collection for the simplified data storage**

NOTE – The numbering of data buffers allows to identify unique types of data; regular data storage based on standard [IEEE 1588-2019] Annex J (from 0 to 98), with 15 minutes and 24 h granularity and simplified data storage (from 100 to 122) with 3 minutes and 1 hour granularity.

## F.2 Use cases when local PTP clock is not used for timestamping

There are several use cases where the local precision time protocol (PTP) clock is not used for timestamping. For example, when the system has access to an alternative accurate and reliable reference, the performance monitoring data is calculated with reference to this accurate and reliable reference.

In particular, the following use cases are currently addressed:

- When a local GNSS is used as a primary reference (not modelled as a virtual PTP port), and the PTP reference is used as a back up (the selection is made outside the PTP);
- When a PTP node has access to an active [ITU-T G.8275.1], PTP reference and a [ITU-T G.8275.2] reference is used for back up.

Additional use cases (e.g., GNSS local reference modelled via a virtual PTP port or, in general, when the PM data is collected from ports that are not in the TIME\_RECEIVER state) are for further study.

## F.3 Considerations for [ITU-T G.8275.2]

In the case of the unicast profile [ITU-T G.8275.2], additional care should be taken with the PTP event messages used to compute the TR-TT-Delay and TT-TR-Delay parameters. The intention is for the statistics based on the TR-TT-Delay and TT-TR-Delay to be readily used to compare against the network limits specified in [ITU-T G.8271.2]. In this way it is possible for a network operator to compare in a consistent way the results of the measurements performed by the different implementations. As such, the use of a subset of all the PTP event messages that approximates the network limit selection criteria is helpful (refer to [ITU-T G.8271.2] clause 7.3.1.1). If this is not possible, and with the assumptions that the monitoring based on the packet selection criteria of the specific implementation would not provide significant differences if compared with the [ITU-T G.8271.2] principles, the TR-TT-Delay and TT-TR-Delay parameters should be calculated every 15 or 3 minutes by using the packets selected by the clock recovery during this interval. The statistics representing the number of various PTP messages are counted over the full data set.

NOTE – In the case of APTS, when the GNSS is available, the performance monitoring data is calculated with reference to the local reference clock (locked to GNSS). In this way it is possible to measure the network performance with respect to a local accurate reference. As an example, the offsetFromTT based statistics can provide an indication of the asymmetry caused by the PTP-unaware network.

## F.4 Time reference information

To inform the network management system about which reference is used for the PM measurement defined in Table F.1, the ClockPerformanceMonitoringDataRecord data type is amended to include the PMref parameter as shown below:

```
Struct ClockPerformanceMonitoringDataRecord
```

```
{  
  UInteger16 index;  
  Boolean measurementValid;  
  Boolean periodComplete;  
  PMTimestamp PMTime;  
  TimeInterval <parameter 1>
```

```
..
```

TimeInterval <parameter 16>;

Boolean PMref;

};

Where PMref is defined as follows:

- TRUE: the Local PTP Clock (as per [IEEE 1588-2019]) is used to compute the statistics in Table F.1
- FALSE: the Local PTP Clock (as per [IEEE 1588-2019]) is not used to compute the statistics in Table F.1

NOTE – Only when a PTP instance has a port in TIME\_RECEIVER state, the PM data collection is performed.

## Appendix I

### Architecture for time and phase distribution over a packet network providing PTS at the protocol level

(This appendix does not form an integral part of this Recommendation.)

This appendix describes an alternative to the architecture for time and phase distribution using the full timing support (FTS) described in this Recommendation, where not every network element is required to provide timing support. It will operate over a unicast IP network, in a similar manner to the existing frequency distribution architecture, but adapted to carry time and phase, as well as frequency. The architecture and its associated PTP profile are still under development and the accuracy and stability of time and phase distribution using this architecture is not yet known.

This future architecture is expected to address use cases where the operator wants to distribute accurate time and phase over an existing network and cannot upgrade the network to provide timing support in every network node. Additionally, a portion of the network may be provided by a third party and outside the administrative scope of the primary operator. The performance aspects and impacts of these use cases are still under study.

This appendix presents the initial concepts.

#### I.1 Architecture for PTS

The following four architectural aspects are covered in this appendix:

- 1) general packet-based timing distribution architecture;
- 2) timing protection aspects and functions;
- 3) partitioning across multiple administrative domains;
- 4) use of multiple underlying technologies.

##### I.1.1 Timing distribution architecture

[ITU-T G.8265] describes an architecture for frequency distribution using packet timing protocols. In this architecture, a frequency reference is connected to a pTT clock and distributed to the pTR clock using packet timing signals. The packet network itself is "timing unaware", i.e., it does not contain any elements that provide assistance or correction to the packet timing signals.

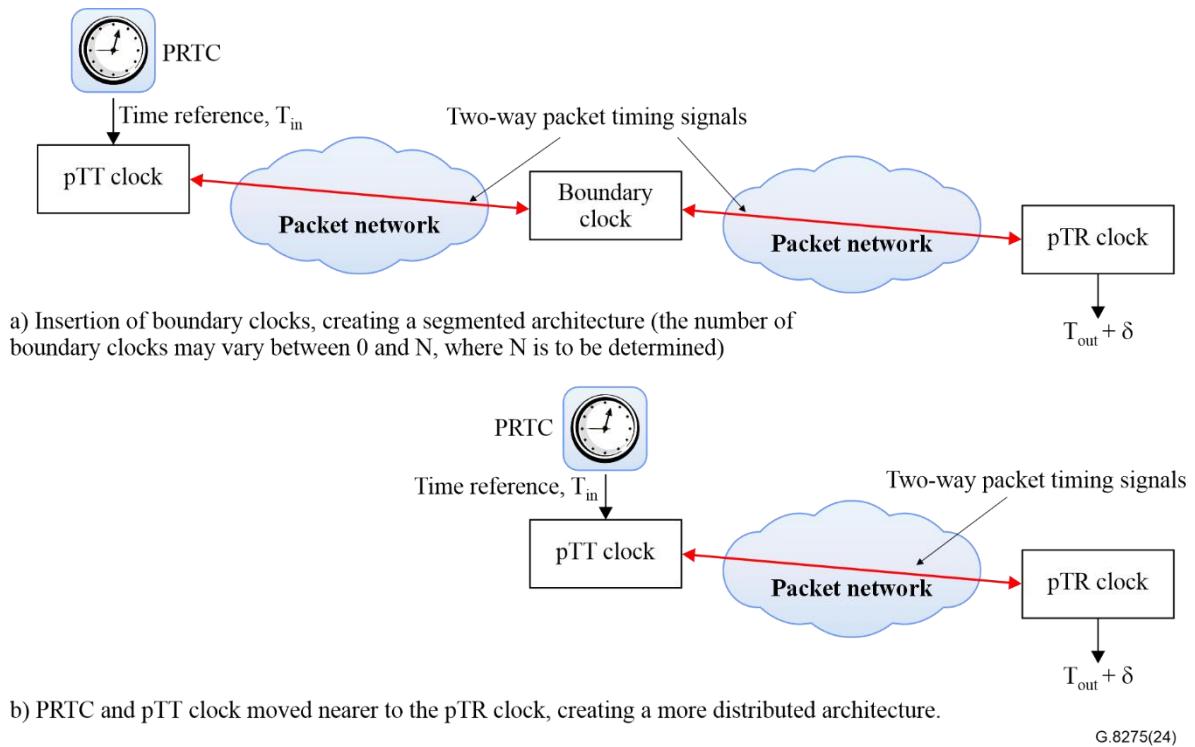
The same method can be considered and adapted to distribute time and phase to the pTR clock. This requires changing the frequency reference to a time reference derived from a PRTC (PRTC, normally a GNSS receiver referencing time back to UTC). It also requires the timing protocol to operate in a two-way mode, i.e., to send event messages in both directions. If the PTP protocol is used, this means using both *sync* and *delay\_request* messages.

The applications requiring accurate time and phase distribution described in [ITU-T G.8271] place a much more stringent requirement on the network and the pTR clock performance than for the frequency distribution. The objective is to address some of the classes described in [ITU-T G.8271]. To achieve this, it may be required to reduce the number and type of network elements that can be traversed compared to [ITU-T G.8265.1] / [ITU-T G.8261.1] while still meeting the performance requirements.

There are two main ways to accommodate this reduction:

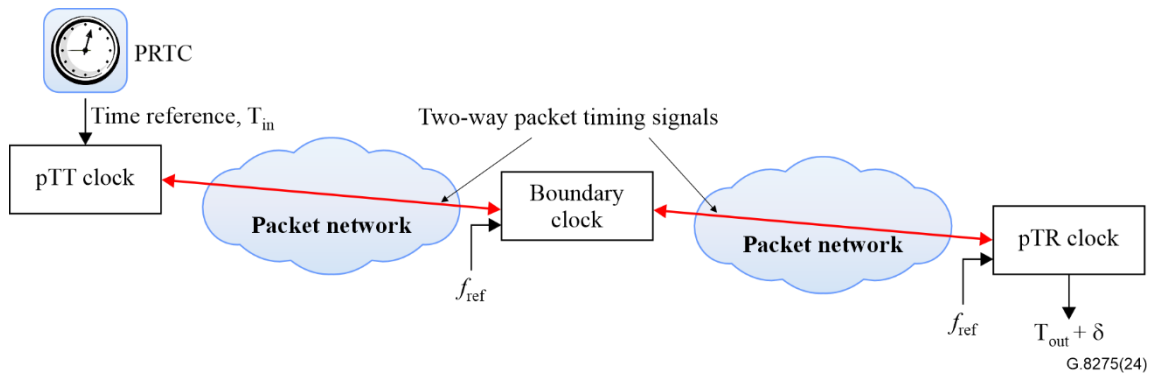
- 1) use boundary clocks to break the network up into smaller segments (boundary clocks recover and filter the timing from the original packet timing signal and generate a new packet timing signal to forward the timing downstream);
- 2) move the PRTC and pTT clock closer to the pTR clock (i.e., a more distributed architecture).

These approaches are shown in Figure I.1:



**Figure I.1 – Modified architecture to support time and phase distribution**

In both the cases, the stability and performance of the boundary clocks and pTR clock may be enhanced by the provision of a stable physical layer frequency reference, such as a synchronous Ethernet, if available, as shown in Figure I.2:



**Figure I.2 – Use of a physical layer frequency reference (if available)**

The specification of the boundary clock in Figure I.2 is not identical to the boundary clock for FTS. Similarly, the specification of the packet timeReceiver (pTR) clock in Figure I.2 is not the same as the pTR clock for FTS or the pTR clock for frequency described in [ITU-T G.8263].

Performance specifications for the clocks described in this appendix are for further study.

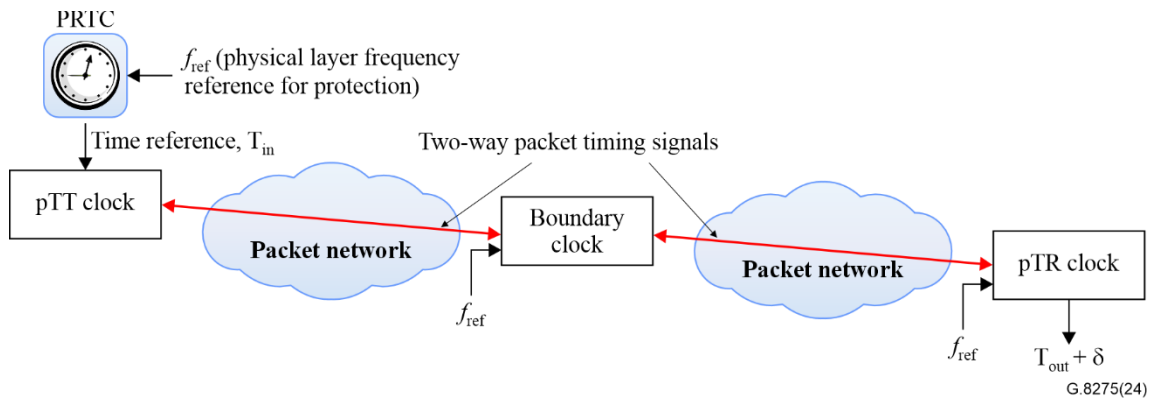
### I.1.2 Timing protection aspects

One method of providing protection in case of a network failure is to provide access to an alternative packet timeTransmitter (pTT) clock or a boundary clock. The details of the TT selection mechanism are under study.



A second method of protection is based on the use of a frequency reference (if available) to maintain the time base of the various clocks. For example, [ITU-T G.8272] describes the use of a frequency reference (such as a synchronous Ethernet) to maintain the PRTC output during periods when the GNSS signal is unavailable.

This method can be applied to both the boundary clock and the pTR clock. A physical layer frequency reference, if available, can be used to maintain the time output of the boundary clock and/or pTR clock during periods when the packet timing signal is either unavailable or unusable. This is shown in Figure I.3:

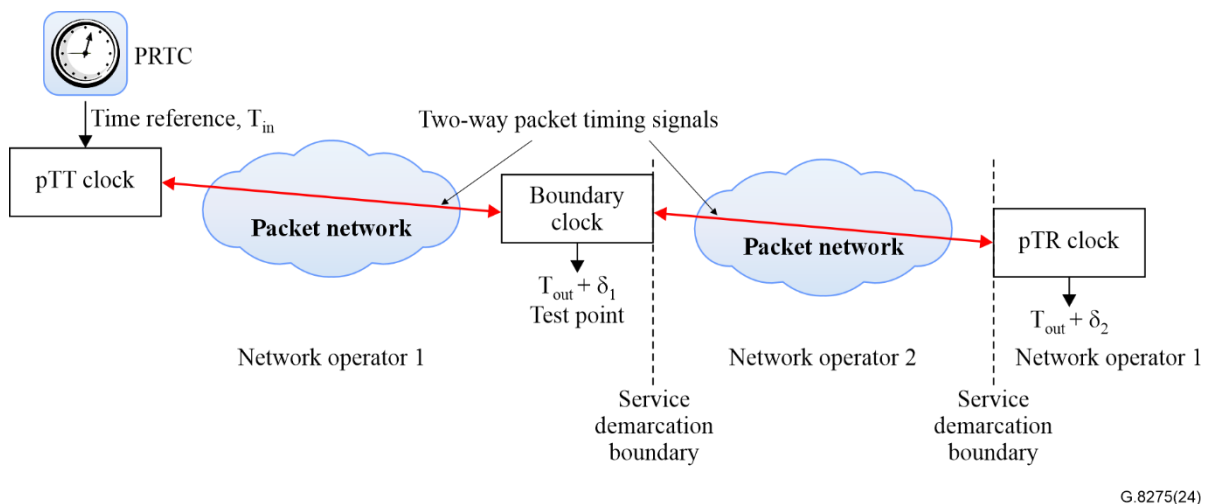


**Figure I.3 – Protection using physical layer frequency references**

### I.1.3 Partitioning across multiple administrative domains

In some cases, operators purchase services from other operators in order to provide access to remote equipment or networks. The use of the partial timing support (PTS) architecture permits the distribution of time and phase across such alternative access vendors, even where such vendors may not provide timing support, although the performance of such timing distribution schemes may be undefined.

For example, Figure I.4 shows an example of such an alternative access provision. In this example, a boundary clock is used to ensure a clean hand-off point to the second network operator.



**Figure I.4 – Timing transmission over a second operator's network**

Passing accurate phase/time between administrative domains is for further study. Issues surrounding the demarcation of the packet timing flow and the transferred performance between operators may exist. It may be difficult to determine the location of the performance problems especially if the packet timing is passing through multiple administrative domains.

When multiple administrative domains are involved, other methods may be required to deliver accurate phase/time reference to the mobile network operator. For instance, a carrier operator may provide a phase/time reference as a service. The details of these other methods are for further study.

#### **I.1.4 Use of multiple underlying technologies**

Packet networks are built on a number of different underlying technologies. Some technologies not only create a packet delay variation (PDV), but also introduce significant asymmetry or difference in delay between the forward and reverse paths. If uncorrected, this asymmetry will cause an error in the pTR clock estimate of the correct time or phase.

Where such technologies are used, it will be necessary to verify that they are suitable for accurate time and phase transfer, or that appropriate timing support has been built into the equipment. Details of the PDV and the asymmetry contributions of individual transport technologies and their suitability for accurate time and phase distribution are for further study.

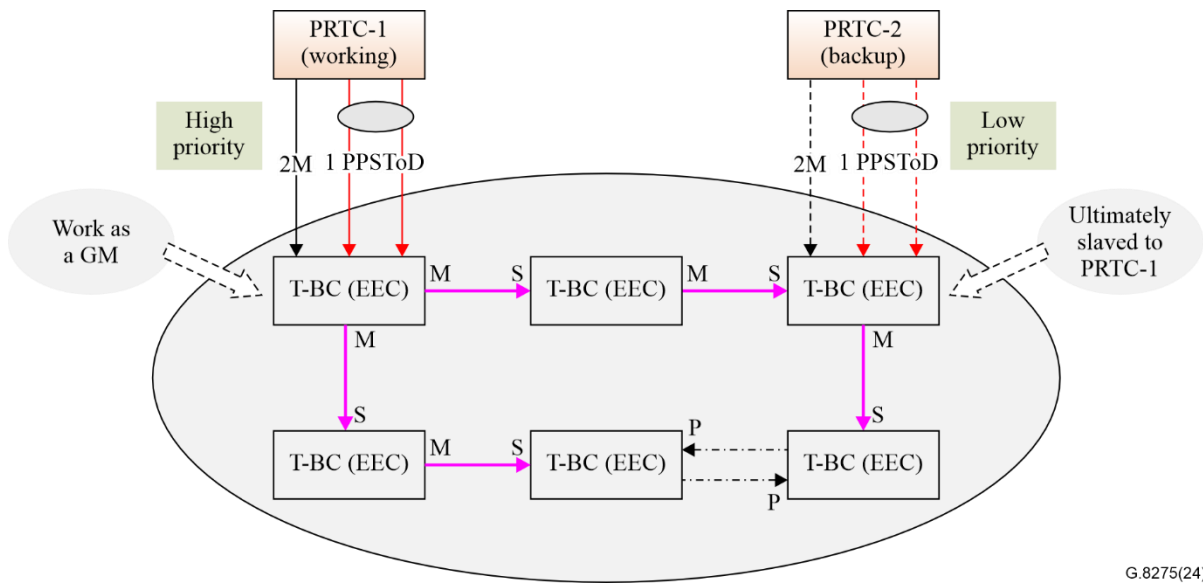
## Appendix II

### An example of PRTC switching by the BTCA in a ring network

(This appendix does not form an integral part of this Recommendation.)

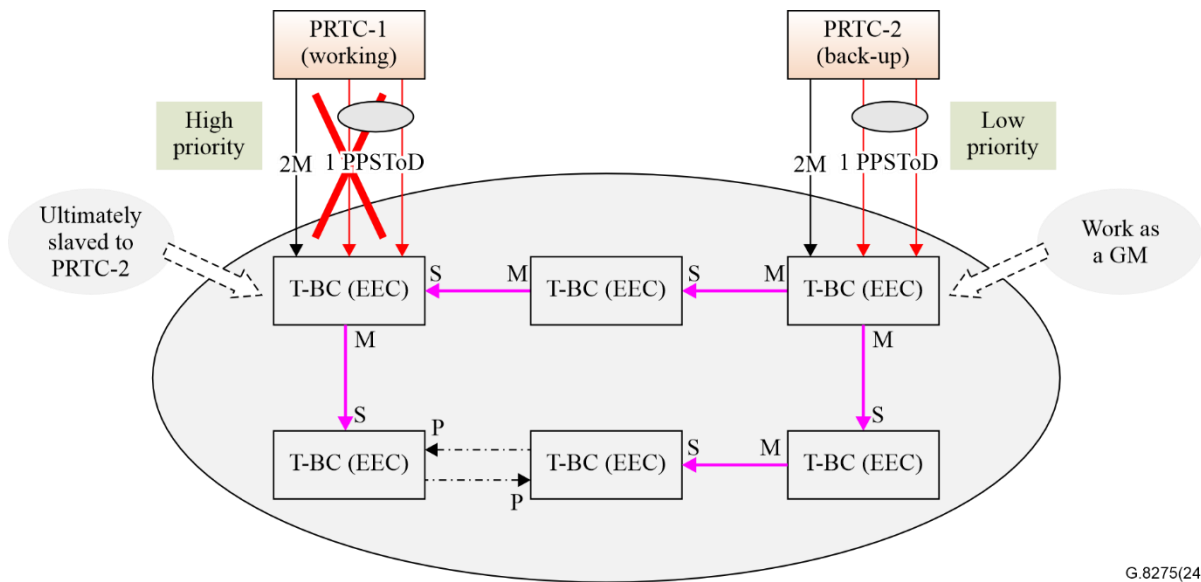
Figure II.1 and Figure II.2 show the normal and abnormal application scenarios. In the figures, the working primary reference time clock (PRTC) has a higher priority than the backup PRTC.

Normally, the working PRTC (i.e., PRTC-1) sends frequency via a 2 048 kHz or 2 048 kbit/s signal and phase/time via a 1 PPS + ToD signal to the T-BC that it is connected to. This T-BC is the GM, and all the network elements including the T-BC connected to the backup PRTC (i.e., PRTC-2) track the phase/time of the working PRTC, as shown in Figure II.1.



**Figure II.1 – Normal state (T-BC connected to working PRTC is working as a GM)**

If, at some time, PRTC-1 is degraded (e.g., the GNSS signal is lost), or the connection between PRTC-1 and the T-BC it is connected to fails, PRTC-2 becomes the working PRTC. All the network elements will then track the phase/time of PRTC-2, and the T-BC initially connected to PRTC-1 will no longer be the GM, as shown in Figure II.2.



G.8275(24)

**Figure II.2 – Abnormal state (the working PRTC has failed)**

The above operation can be obtained using the best TimeTransmitter clock algorithm (BTCA) by setting the clockClass of PRTC-1 and PRTC-2 to 6 when they are operating normally (i.e., when they are traceable to a GNSS) and setting priority2 for PRTC-1 to be better (i.e., to have a smaller value) than priority2 for PRTC-2. Both PRTC-1 and PRTC-2 are attached to the respective T-BCs via virtual PTP ports (see [ITU-T G.8275.1]), and the respective PTP attributes, which include clockClass and priority2 are transferred via the 1 PPS+ToD interfaces to the virtual PTP ports (see [ITU-T G.8271]). With these values for clockClass and priority2 (and with clockAccuracy and offsetScaledLogVariance of PRTC-1 and PRTC-2 the same) PRTC-1 will win the BTCA when it is operating normally because its clockClass will be the same or better than the clockClass of PRTC-2 and its priority2 will be better than priority2 of PRTC-2. If PRTC-1 degrades, its clockClass will be worse than that of PRTC-2 and PRTC-2 will win the BTCA. If PRTC-1 is lost (i.e., the connection from PRTC-1 to the T-BC it is attached to is cut), there will be no input to the virtual PTP port and PRTC-2 will win the BTCA.

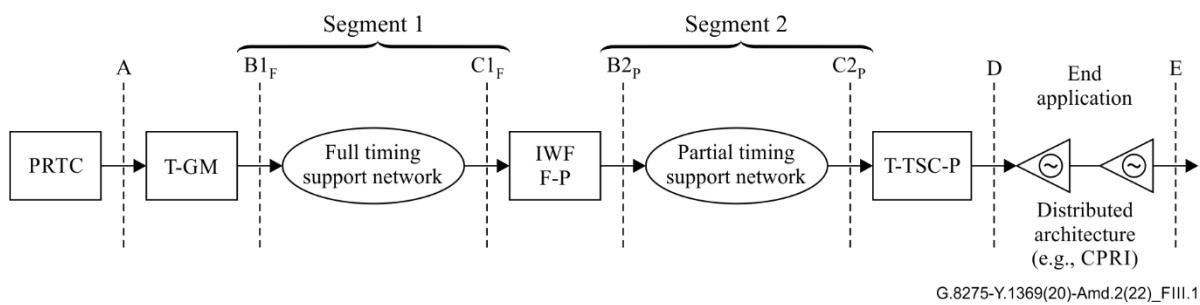
## Appendix III

### Generic IWF node

(This appendix does not form an integral part of this Recommendation.)

#### III.1 Introduction

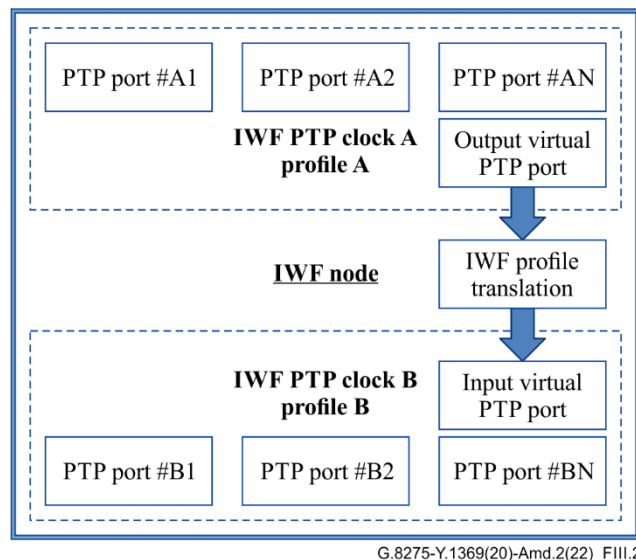
In some deployment scenarios, an inter-working function (IWF) may be used to connect synchronization network segments that are running different precision time protocol (PTP) profiles. An example is shown below in Figure III.1 where an IWF node, containing a clock among other functions, would be needed to translate from the FTS profile ([ITU-T G.8275.1]) to the PTS ([ITU-T G.8275.2]) going downstream from the T-GM towards the end application. In this case, the IWF node may be denoted as IWF F-P to indicate the direction of the profile translation from full to partial. Similarly, IWF P-F indicates the direction of the profile translation from partial to full.



**Figure III.1 – Deployment case requiring IWF node**

A model for the IWF node is shown in Figure III.2. This IWF node uses a virtual PTP port to interconnect PTP clocks from different PTP profiles. The IWF node consists of several aspects.

- IWF PTP clock A, running profile A
  - several PTP ports
  - output virtual PTP port
  - clock A datasets
- IWF PTP clock B, running profile B
  - several PTP ports
  - input virtual PTP port
  - clock B datasets
- IWF profile translation



**Figure III.2 – Model of a telecom profile IWF node**

Figure III.2 profile IWF node represents the same concept that was later introduced in [IEEE 1588-2019] as a "PTP profile gateway" in Annex O, specifically Figure O.7 of [IEEE 1588-2019], with

- Output virtual PTP port block seen as the "sink adapter block",
- Profile translator block seen as the "profile / domain adapter block",
- Input virtual PTP port seen as the "source adapter block".

A typical scenario would have a uni-directional timing service flowing from one profile (profile A) to the other profile (profile B). The performance of such a node may be defined in a Recommendation and may be built as a timeReceiver clock of profile A and a grandmaster clock of profile B, where profile A and profile B are participating in different PTP domains. Continuing the description of the typical scenario, the IWF PTP clock A, configured with profile A, would operate as a timeReceiverOnly clock, while the IWF PTP clock B, configured with profile B, would operate as a grandmaster clock with timeTransmitterOnly PTP ports. The IWF PTP clock A would comply with all the requirements defined for profile A and the IWF PTP clock B would comply with all the requirements defined for profile B.

For IWF F-P and P-F, the node performance limits mainly consider the type of network used on the timeReceiver port, regardless of the one used on the timeTransmitter port.

- For a synchronization interworking function IWF F-P translating from the FTS profile ([ITU-T G.8275.1]) to the PTS profile ([ITU-T G.8275.2]), the performance limits may be the same as those for a T-BC in [b-ITU-T G.8273.2].
- For a synchronization interworking function IWF P-F translating from the PTS profile ([ITU-T G.8275.2]) to the FTS profile ([ITU-T G.8275.1]), the performance limits may be the same as those for a T-BC-A or T-BC-P in [b-ITU-T G.8273.4].

However, application-specific implementations with different limits are also allowed. It is the responsibility of the operator to choose the appropriate type of IWF node based on the network configuration.

### **III.2 Inter-working between the [ITU-T G.8275.1] and [ITU-T G.8275.2] profiles**

The interworking function translating between the [ITU-T G.8275.1] and [ITU-T G.8275.2] profiles is simplified due to the many common aspects shared between these two profiles. Table III.1 outlines the areas of commonality as well as differences between the two profiles.

**Table III.1 – Common aspects and differences between the [ITU-T G.8275.1] and [ITU-T G.8275.2] profiles**

Functionality	[ITU-T G.8275.1]	[ITU-T G.8275.2]
Network support	FTS from network	PTS from the network
Transport layer	Transport of PTP over [b-IEEE 802.3]/Ethernet Transport of PTP over optical transport network (OTN).	PTP transport over UDP/IPv4 PTP transport over UDP/IPv6
Domain	24-43	44-63
deviceTypes (BC)	T-BC (synchronized by another PTP clock, or can become T-GM)	T-BC-P, T-BC-A
Message rates	Fixed rates <ul style="list-style-type: none"> <li>• Sync: 16 pkts/s</li> <li>• Delay_req: 16 pkts/s</li> <li>• Announce: 8 pkts/s</li> <li>• Signalling FFS</li> <li>• Management FFS</li> </ul>	Negotiated rates <ul style="list-style-type: none"> <li>• Sync: 1-128 pkts/s</li> <li>• Delay_req: 1-128 pkts/s</li> <li>• Announce: 1-8 pkts/s</li> <li>• Signalling: used for unicast rate negotiation</li> <li>• Management FFS</li> </ul>
Network architecture	Use-cases and architecture per ITU-T G.8275 (this Recommendation)	
BTCA	Common (same) ABTCA	
Fields ignored (common behaviour)	controlField, priority1, PTP profile specific 1,2 = FALSE, Reserved = FALSE	
Fields ignored (different behaviour)	unicastFlag	–
Fields used (common behaviour)	<ul style="list-style-type: none"> <li>• ptpTimescale must be TRUE (not ignored, it must actually be true)</li> <li>• twoStepFlag, leap61, leap59, currentUtcOffsetValid same definition as [IEEE 1588]</li> <li>• timeTraceable, frequencyTraceable</li> </ul>	
Fields used (different behaviour)	unicastFlag must be FALSE	unicastFlag must be TRUE
Asymmetry control	–	Static asymmetry controlled using assisted PTS
Physical layer	Physical layer frequency support using SyncE/E1/T1	Physical layer frequency support is optional
Unicast negotiation support	No (not allowed)	Yes (allowed – must be supported)
VLAN allowed	No	Yes

When the PTP profiles are part of an IWF node, they may be modelled as inter-connected using a virtual PTP port that is described in Annex B through an IWF profile translation block. Table III.2 provides information on how these parameters can be set or translated between profiles in the IWF profile translation block. This Table does not define that these must be the values used on the internal virtual PTP port inside the equipment.

**Table III.2 – Translation between the [ITU-T G.8275.1] and the [ITU-T G.8275.2] profiles**

Group	Field	In profile A: [ITU-T G.8275.1]  Out profile B: [ITU-T G.8275.2]	In profile A: [ITU-T G.8275.2]  Out profile B: [ITU-T G.8275.1]
Time properties DS	Leap61	Direct mapping	Direct mapping
Time properties DS	Leap59	Direct mapping	Direct mapping
Time properties DS	currentUtcOffsetValid	Direct mapping	Direct mapping
Time properties DS	ptpTimescale	No translation; set TRUE	No translation; set TRUE
Time properties DS	timeTraceable	Direct mapping	Direct mapping
Time properties DS	frequencyTraceable	Direct mapping	Direct mapping
Time properties DS	timeSource	Direct mapping	Direct mapping
Time properties DS	currentUtcOffset	Direct mapping	Direct mapping
Parent DS	grandmasterIdentity	Note 1	Note 1
Parent DS	grandmasterClockQuality.clockClass	Direct mapping	Direct mapping
Parent DS	grandmasterClockQuality.clockAccuracy	Note 2	Note 2
Parent DS	grandmasterClockQuality.offsetScaledLogVariance	Note 2	Note 2
Parent DS	grandmasterPriority1	Direct mapping	Direct mapping
Parent DS	grandmasterPriority2	Direct mapping	Direct mapping
Other	stepsRemoved	0	0
Other	version	No translation; set by 'Profile B'	No translation; set by 'Profile B'
Other	domain number	No translation; set by 'Profile B'	No translation; set by 'Profile B'
Other	Time of day	From 'Profile A' clock	From 'Profile A' clock
Local	Signal Fail (SF)	See Annex B, Note 2	See Annex B, Note 2
Local	localPriority	No translation, set by 'Profile B'	No translation, set by 'Profile B'
Local	port number	See Annex B, Note 4	See Annex B, Note 4
<p>NOTE 1 – The grandmasterIdentity assigned to the input virtual PTP port is the clockIdentity of the PTP clock profile B.</p> <p>NOTE 2 – The clockQuality.clockAccuracy and clockQuality.offsetScaledLogVariance should reflect the actual (degraded) clockQuality of the PTP connection at reference point B<sub>2P</sub> (see Figure III.1), if known. Otherwise, clockQuality.clockAccuracy and clockQuality.offsetScaledLogVariance are directly mapped.</p>			

### III.3 Generation of the physical layer frequency signal by the IWF

A synchronization IWF F-P node has an input PTP reference timing signal carried over an FTS synchronization network that includes a mandatory physical layer frequency signal (e.g., SyncE, SDH, etc.), and delivers a PTP reference timing signal carried over a PTS synchronization network.



NOTE 1 – The physical layer frequency signal generation is optional on the PTS port(s). If used, it is specified by the physical layer-based frequency synchronization requirements ([b-ITU-T G.812], [ITU-T G.8262], and [ITU-T G.8262.1] for frequency and time error, [b-ITU-T G.781] and [ITU-T G.8264] for SSM QL-TLV).

A synchronization IWF P-F node has an input PTP reference timing signal carried over a PTS synchronization network that includes an optional physical layer frequency signal (e.g., SyncE, SDH, etc.), and delivers a PTP reference timing signal carried over an FTS synchronization network.

NOTE 2 – The physical layer frequency signal generation is mandatory on the FTS port(s). If a valid physical layer frequency signal is delivered by the upstream PTS network and if the synchronization IWF P-F node supports the distribution of such a signal, then this distribution is specified by the physical layer-based frequency synchronization requirements ([b-ITU-T G.812], [ITU-T G.8262], [ITU-T G.8262.1] for frequency and time error, [b-ITU-T G.781] and [ITU-T G.8264] for SSM QL-TLV). Otherwise, the quality level to be used on the physical layer frequency signal shall be generated following the rules defined in Annex F of [ITU-T G.8275.2].

### III.4 Mapping IWF to telecom PTP clocks

An IWF F-P is used to denote an IWF node that translates from the FTS profile ([ITU-T G.8275.1]) to the PTS profile ([ITU-T G.8275.2]); the direction of the profile translation is full to partial. In this case the IWF F-P may be modelled as a combination of a T-TSC or T-BC (represented by the inner element IWF PTP clock A in Figure III.2) from [ITU-T G.8275.1] and a T-GM (represented by the inner element IWF PTP clock B in Figure III.2) from [ITU-T G.8275.2].

An IWF P-F is used to denote an IWF node that translates from the PTS profile ([ITU-T G.8275.2]) to the full timing support (FTS) profile ([ITU-T G.8275.1]); the direction of the profile translation is partial to full. In this case the IWF P-F may be modelled as a combination of a T-TSC-A or T-TSC-P (represented by the inner element IWF PTP clock A in Figure III.2) from [ITU-T G.8275.2] and a T-GM (represented by the inner element IWF PTP clock B in Figure III.2) from [ITU-T G.8275.1]).

The modelling of the IWF F-P and the IWF P-F as telecom clocks from [ITU-T G.8275.1] and [ITU-T G.8275.2] does not imply that the IWF node is compliant with all the requirements for those equipment clocks, which are designed to be used as a standalone equipment.

**Table III.3 – Mapping between IWF node type, [ITU-T G.8275.1], [ITU-T G.8275.2] deviceTypes and IEEE 1588 clockTypes**

<b>IWF node type</b>	<b>PTP profile</b>	<b>deviceTypes from [ITU-T G.8275.1] and [ITU-T G.8275.2]</b>	<b>clockTypes from [IEEE 1588]</b>
<b>IWF F-P</b>	A (ITU-T G.8275.1)	T-TSC or T-BC	OC or BC
	B (ITU-T G.8275.2)	T-GM	OC or BC
<b>IWF P-F</b>	A (ITU-T G.8275.2)	T-TSC-P or T-TSC-A	OC or BC
	B (ITU-T G.8275.1)	T-GM	OC or BC

## Appendix IV

### Use cases for mapping from PTP clockClass values to quality levels

(This appendix does not form an integral part of this Recommendation.)

This appendix provides use cases for mapping from PTP clockClass values to quality levels (QLs) for use by synchronization status message (SSM) and Ethernet synchronization messaging channel (ESMC) when using the PTP time profile for frequency recovery.

#### IV.1 Use case I

Due to the evolution from 3G to 4G, base stations of different generations coexist. In some situations, two different base stations, such as where a wideband code division multiple access (WCDMA) station and a long-term evolution (LTE) station are connected to the same node. As shown in Figure IV.1, a WCDMA station and an LTE station are connected to the same [ITU-G.8275.2] T-TSC-P/T-TSC-A node. The WCDMA station requires a frequency signal from the T-TSC-P/T-TSC-A node. However, in the scenario of partial-PTP timing support, the node can only get PTP messages through the middle network that does not support PTP and SyncE functions. Therefore, to provide a frequency signal to the WCDMA station, the T-TSC-P/ T-TSC-A node has to transform the PTP clockClass values into QLs. In this case, the mapping from PTP clockClass values to QLs is required.

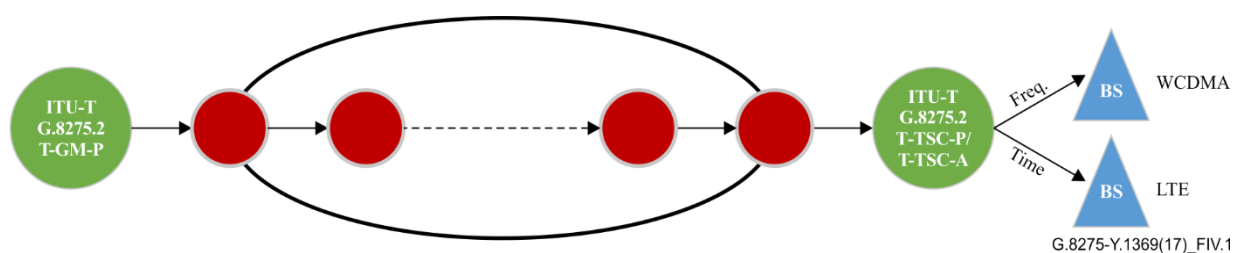


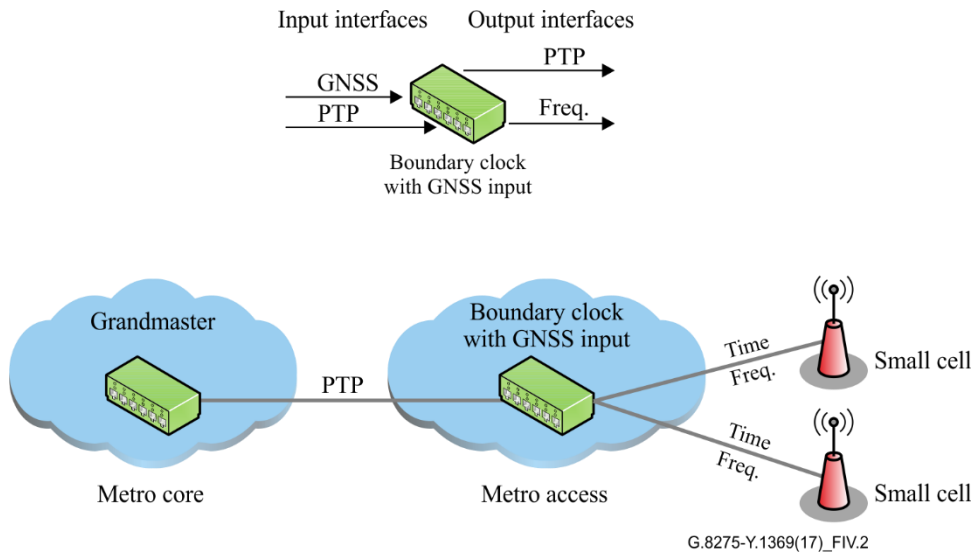
Figure IV.1 – Use case I

#### IV.2 Use case II

To provide frequency and time service to a local network area (e.g., to deploy the small cells in a building) and meet the stringent accuracy requirement, one possible convenient solution is to deploy a boundary clock with a global navigation satellite system (GNSS) input close to an access network area rather than rely on the grandmaster (GM) in the core network.

This type of boundary clock with a GNSS input usually supports at least two types of input sources: GNSS or PTP input from the upstream network. The boundary clock with a GNSS input also provides the PTP output and frequency output (e.g., SyncE or 2 048 kHz / 2 048 kbit/s) simultaneously, to support various applications.

When the boundary clock with a GNSS input chooses the PTP input and provides the frequency output, it should support transforming the PTP clockClass values into QLs. For example, in Figure IV.2, the boundary clock with the GNSS input is deployed close to the small cells and provides services for users within a certain area. The boundary clock with the GNSS input may get a time source via a full- or partial-PTP path. At the same time, the boundary clock with the GNSS input offers time and frequency services to the small cells. To provide frequency service for the small cells, the mapping from PTP clockClass values to QLs is also required for the boundary clock with the GNSS input.



**Figure IV.2 – Use case II**

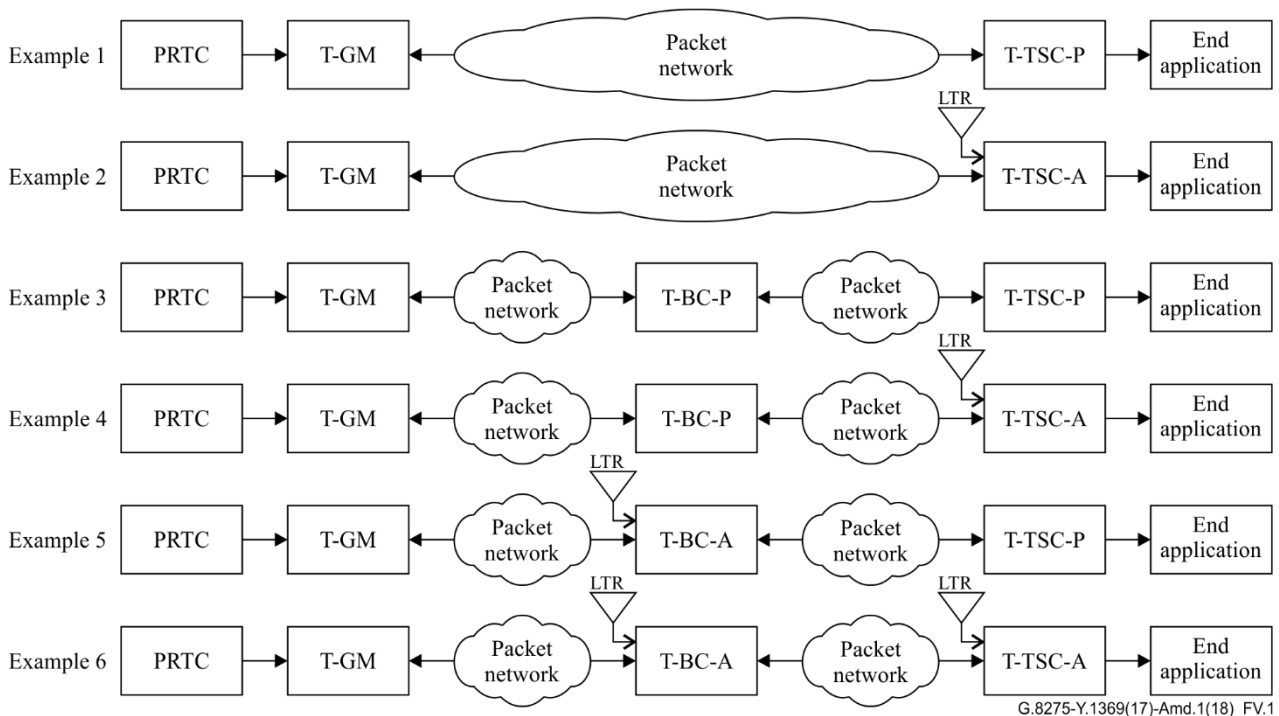
## Appendix V

### Deployment examples and the use of partially aware deviceTypes

(This appendix does not form an integral part of this Recommendation.)

This Recommendation includes several partially aware deviceTypes: T-TSC-A, T-TSC-P, T-BC-A and T-BC-P. Figure V.1 illustrates the potential use of these clocks in example network deployments. The examples included in the figure are not meant to be exhaustive of all the possible network deployments, but it shows a few simple examples that provide clarity between the partially aware deviceTypes.

- Example 1 shows a T-GM with a direct PTP connection to a T-TSC-P, without any intermediate T-BC-P or T-BC-A.
- Example 2 shows a T-GM with a direct PTP connection to a T-TSC-A that has local time reference (LTR) support for asymmetry compensation, without any intermediate T-BC-P or T-BC-A.
- Example 3 shows a T-GM with a PTP connection to a T-BC-P, which in turn has a PTP connection to a T-TSC-P.
- Example 4 shows a T-GM with a PTP connection to a T-BC-P, which in turn has a PTP connection to a T-TSC-A. The T-TSC-A has local time reference support for asymmetry compensation.
- Example 5 shows a T-GM with a PTP connection to a T-BC-A, which in turn has a PTP connection to a T-TSC-P. The T-BC-A has local time reference support for asymmetry compensation.
- Example 6 shows a T-GM with a PTP connection to a T-BC-A, which in turn has a PTP connection to a T-TSC-A. The T-TSC-A has local time reference support for asymmetry compensation.



**Figure V.1 – Scenarios showing T-BC-A and T-BC-P in PTS and APTS**

NOTE 1 – The PRTC and the T-GM may be embedded in the same equipment.

NOTE 2 – The T-TSC-A or T-TSC-P and the end application clock may be embedded in the same equipment.

NOTE 3 – The local time reference may be in a separate, co-located equipment, or embedded within the same equipment, as the T-BC-A or T-TSC-A.

NOTE 4 – The examples show no or one T-BC-P or T-BC-A between the T-GM and the T-TSC-P or T-TSC-A; other numbers of T-BC-P or T-BC-A are also possible.

## **Appendix VI**

### **cnPRTC functional architecture**

(This appendix does not form an integral part of this Recommendation.)

The contents of this appendix have been moved into Appendix I of [b-ITU-T G.8272.2].

## Appendix VII

### cnPRTC deployment scenarios

(This appendix does not form an integral part of this Recommendation.)

For coherent network PRTC (cnPRTC) network deployment, the following scenarios are proposed for a step-by-step deployment approach. The scenarios can be regarded as network migration guidelines.

The network specific deployment depends on many factors, such as specific network architecture, availability of time transfer links, network size, etc. Therefore, using the specific scenarios for a specific network is up to the network operator.

#### Scenario 1:

- As basis: To deploy stand-alone enhanced PRTC (ePRTC) functions according to [b-ITU-T G.8272.1].
- This scenario would allow a network operator to start with several ePRTC functions according to [b-ITU-T G.8272.1] at centralized locations. Connecting time transfer links are not needed.

#### Scenario 2:

- To mesh neighbourhood cnPRTC location with time transfer links.
- This scenario introduces time transfer links from / to neighbourhood locations which allow measurement between them, in order to have the performance under control and have an early fault detection mechanism. Depending on the network operator's implementation strategy and roll-out time frame, this scenario may not be needed for specific networks.

#### Scenario 3

- Active usage of all available sources for local timescale generation.
- Scenario 3 provides the full cnPRTC functionality according to the architectural concept as part of [ITU-T G.8275] in a very robust way to overcome any GNSS issues or any system defects.  
All sources will be used for local timescale generation including frequency, phase, and time according to their individual assigned weight.

Table VII.1 provides an overview of the three deployment scenarios:

**Table VII.1 – Summary of deployment scenario capabilities**

De- ploy- ment sce- nario #	Used sources and logical functions								Descriptions		
	Local sources		Remote sources			Logical functions					
	PRC/ ePRC	PRTC	Time Transfer links 1) from/to neigh- borhood e/cnPRTC nodes		UTC(k)  from a remote UTC(k) lab	Measure- ment function	Clock Com- biner function	Output function		GNSS Common view	
for measure- ment			for local ensem- bling 2)								
1	YES	YES	NO	NO	Optional	Optional	YES	YES	Optional	Stand-alone ePRTC according to G.8272.1	
2	YES	YES	YES	NO		Optional	YES	YES		YES	Like cnPRTC, but monitoring the remote sources only
3	YES	YES	YES	YES		Optional	YES	YES		YES	Final cnPRTC architecture , remote sources are actively used
1)	e. g. IEEE1588v2.1 (High-accuracy profile), or ITU-T PTP-FTS/SyncE										
2)	to contribute to local time										



## Appendix VIII

### Description of PTP clock modes and associated contents of Announce messages

(This appendix does not form an integral part of this Recommendation.)

#### VIII.1 Purpose of this appendix

This appendix provides information related to possible T-GM, T-BC, T-BC-P, and T-BC-A clock modes. The intention of the clock mode information is to provide a high-level indication of the operational status of the entire clock as opposed to just individual precision time protocol (PTP) ports. It provides a mapping between the clock modes and the PTP port states as defined in [IEEE 1588]. In addition, it provides a table showing the content of the *Announce* message fields that will occur in the various clock modes.

The acquiring clock mode, if included in an implementation, allows a T-GM, T-BC, T-BC-P, or T-BC-A to delay the distribution of grandmaster (GM) information transmitted by the clock. The purpose of this acquiring clock mode is to allow a T-GM T-BC, T-BC-P, or T-BC-A some time to establish a timescale with acceptable accuracy before using it for the clock's node time.

NOTE – The procedures defined within this appendix for the Acquiring clock mode are not compliant with the procedures of [IEEE 1588] and the delay introduced by this mode can impact the overall settling time during PTP topology rearrangements.

Network deployments including clocks using the procedures of this appendix are under the operator's responsibility.

#### VIII.2 Description of the modes

– Free-Run mode

The PTP clock has never been synchronized to a time source and is not in the process of synchronizing to a time source.

As it relates to the PTP port state defined in [IEEE 1588], a clock is in free-run mode if there are no PTP ports in: PRE\_TIME\_TRANSMITTER, PASSIVE, UNCALIBRATED or TIME\_RECEIVER states.

– Acquiring mode

The PTP clock is in the process of synchronizing to a time source. The duration and functionality of this mode is implementation specific. This mode is not required in an implementation.

As it relates to the PTP port state defined in [IEEE 1588], a clock is in acquiring mode if there is a PTP port in the UNCALIBRATED state.

– Locked mode

The PTP clock is synchronized to a time source and is within some internal acceptable accuracy.

As it relates to the PTP port state defined in [IEEE 1588], a clock is in locked mode if there is a PTP port in the TIME\_RECEIVER state.

– Holdover-in-specification mode

The PTP clock is no longer synchronized to a time source and is using information obtained while it was previously synchronized or other information sources were still available, in order to maintain performance within the desired specification. The node may be relying solely on its own facilities for holdover or may use something like a frequency input from the network to achieve a holdover of time and/or phase.

As it relates to the PTP port state defined in [IEEE 1588], a clock is in holdover-in-specification mode if there are no PTP ports in: INITIALIZING, LISTENING, UNCALIBRATED or TIME\_RECEIVER states, and performance is within the desired specification.

– Holdover-out-of-specification mode

The PTP clock is no longer synchronized to a time source and, while it may be using information obtained while it was previously synchronized or other information sources were still available, it is unable to maintain performance within the desired specification.

As it relates to the PTP port state defined in [IEEE 1588], a clock is in holdover-out-of-specification mode if there are no PTP ports in: INITIALIZING, LISTENING, UNCALIBRATED or TIME\_RECEIVER states, and performance is not within the desired specification.

### VIII.3 Example of mapping between PTP port states and PTP clock modes for a 3-port T-BC/T-BC-P/T-BC-A

**Table VIII.1 – PTP port state vs clock mode mapping**

Telecom boundary clock					
	Port state			Clock mode	
Trigger event	Port 1	Port 2	Port 3		Notes
Power up of PTP	INITIALIZING	INITIALIZING	INITIALIZING	Free-run	No port in TT, PASSIVE, UNCALIBRATED, or TR
Clock completes initialization	LISTENING	LISTENING	LISTENING	Free-run	No port in TT, PASSIVE, UNCALIBRATED, or TR
Qualified <i>Announce</i> received from foreign TT on port P1	UNCALIBRATED	LISTENING	LISTENING	Acquiring	A port is in UNCALIBRATED state
ANNOUNCE_RECEIPT_TIMEOUT_EXPIRES event on ports P2 and P3	UNCALIBRATED	TT	TT	Acquiring	A port is in UNCALIBRATED state
Calibration finished on port P1	TR	TT	TT	Locked	A TR port exists on the node
ANNOUNCE_RECEIPT_TIMEOUT_EXPIRES event on port P1	TT	TT	TT	Holdover-in-specification	Start holdover timer No port in TR, UNCALIBRATED, LISTENING, or INITIALIZING
Holdover timer expires	TT	TT	TT	Holdover-out-of-specification	Holdover timer expired and no port in TR, UNCALIBRATED, LISTENING, or INITIALIZING
Port P3 receives qualified <i>Announce</i> with clockClass = 7	TT	TT	UNCALIBRATED	Acquiring	A port is in UNCALIBRATED state
Calibration finished on port P3	TT	TT	TR	Locked	A TR port exists on the node

**Table VIII.1 – PTP port state vs clock mode mapping**

Telecom boundary clock					
	Port state			Clock mode	
Trigger event	Port 1	Port 2	Port 3		Notes
Port P1 receives qualified <i>Announce</i> with clockClass = 6	UNCALIBRATED	TT	PRE_TT	Acquiring	A port is in UNCALIBRATED state
QUALIFICATION_TIMEOUT_EXPIRES event on port P3	UNCALIBRATED	TT	TT	Acquiring	A port is in UNCALIBRATED state
Calibration finished on port P1	TR	TT	TT	Locked	A TR port exists on the node

**VIII.4 T-GM Announce message contents based on the internal PTP clock modes**

**Table VIII.2 – T-GM Announce message contents**

Announce message fields	Free-run mode	Acquiring mode	Locked mode	Holdover-in-specification mode	Holdover-out-of-specification mode
sourcePortIdentity (header.sourcePortIdentity)	Local clockId of the T-GM + Port number	Local clockId of the T-GM + Port number	Local clockId of the T-GM + Port number	Local clockId of the T-GM + Port number	Local clockId of the T-GM + Port number
leap61 (header.flagField)	FALSE	From time source	From time source	TRUE / FALSE (Note 2)	TRUE / FALSE [Implementation specific] (Note 2)
leap59 (header.flagField)	FALSE	From time source	From time source	TRUE / FALSE (Note 2)	TRUE / FALSE [Implementation specific] (Note 2)
currentUtcOffsetValid (header.flagField)	FALSE	TRUE / FALSE [Implementation specific]	TRUE	TRUE / FALSE (Note 2)	TRUE / FALSE [Implementation specific] (Note 2)
ptpTimescale (header.flagField)	TRUE	TRUE	TRUE	TRUE	TRUE
timeTraceable (header.flagField)	FALSE	TRUE / FALSE [Implementation specific]	TRUE	TRUE	FALSE
frequencyTraceable (header.flagField)	TRUE / FALSE based on frequency source lock	TRUE / FALSE based on frequency source lock	TRUE	TRUE / FALSE based on frequency source lock	TRUE / FALSE based on frequency source lock
currentUtcOffset	As per PTP	Based on input reference UTC offset	Based on input reference UTC offset	Last known UTC offset (Note 2)	Last known UTC offset (Note 2)
grandmasterPriority1	128 (default)	128 (default)	128 (default)	128 (default)	128 (default)
grandmasterClockQuality.clockClass	248	Implementation specific, generally previous state	6	7	140/150/160

**Table VIII.2 – T-GM Announce message contents**

Announce message fields	Free-run mode	Acquiring mode	Locked mode	Holdover-in-specification mode	Holdover-out-of-specification mode
		7/140/150/160/248			
grandmasterClockQuality.clockAccuracy	Unknown (0xFE)	Unknown (0xFE)	0x21, 0x20	Unknown (0xFE)	Unknown (0xFE)
grandmasterClockQuality.offsetScaledLogVariance	0xFFFF (default)	0xFFFF (default)	0x4E5D, 0x4B32	0xFFFF (default)	0xFFFF (default)
grandmasterPriority2	Configured priority2 of the T-GM	Configured priority2 of the T-GM	Configured priority2 of the T-GM	Configured priority2 of the T-GM	Configured priority2 of the T-GM
grandmasterIdentity	Local clockId of the T-GM	Local clockId of the T-GM	Local clockId of the T-GM	Local clockId of the T-GM	Local clockId of the T-GM
stepsRemoved	0	0	0	0	0
timeSource	INT_OSC (0xA0)	INT_OSC (0xA0)	As per PTP	INT_OSC (0xA0)	INT_OSC (0xA0)
synchronizationUncertain (header.flagField)	TRUE (Note 3)	TRUE	FALSE (Note 3)	FALSE (Note 3)	TRUE (Note 3)
<p>NOTE 1 – Time properties (leap61, leap59, currentUtcOffsetValid, currentUtcOffset) can be obtained from time source (GNSS or ToD) or user configuration.</p> <p>NOTE 2 – Refer to Table A.8 of [ITU-T G.8275.1] or Table A.6 of [ITU-T G.8275.2].</p> <p>NOTE 3 – Or as defined in Annex D.</p>					

**VIII.5 T-BC/T-BC-P/T-BC-A Announce message contents based on the internal PTP clock modes**

**Table VIII.3 – T-BC/T-BC-P/T-BC-A Announce message contents**

Announce message fields	Free-run mode	Acquiring mode	Locked mode	Holdover-in-specification mode	Holdover-out-of-specification mode
sourcePortIdentity (header.sourcePortIdentity)	Local clockId of the T-BC/T-BC-P/T-BC-A + Port number	Local clockId of the T-BC/T-BC-P/T-BC-A + Port number	Local clockId of the T-BC/T-BC-P/T-BC-A + Port number	Local clockId of the T-BC/T-BC-P/T-BC-A + Port number	Local clockId of the T-BC/T-BC-P/T-BC-A + Port number
leap61 (header.flagField)	FALSE	(Note 1)	(Note 1)	TRUE / FALSE (Note 2)	TRUE / FALSE [Implementation specific] (Note 2)
leap59 (header.flagField)	FALSE	(Note 1)	(Note 1)	TRUE / FALSE (Note 2)	TRUE / FALSE [Implementation specific] (Note 2)
currentUtcOffsetValid (header.flagField)	FALSE	Implementation specific, generally previous state. TRUE / FALSE	(Note 1)	TRUE / FALSE (Note 2)	TRUE / FALSE [Implementation specific] (Note 2)
ptpTimescale (header.flagField)	TRUE	TRUE	(Note 1)	TRUE	TRUE
timeTraceable (header.flagField)	FALSE	Implementation specific,	(Note 1)	TRUE	FALSE

**Table VIII.3 – T-BC/T-BC-P/T-BC-A Announce message contents**

Announce message fields	Free-run mode	Acquiring mode	Locked mode	Holdover-in-specification mode	Holdover-out-of-specification mode
		generally previous state. TRUE / FALSE			
frequencyTraceable (header.flagField)	TRUE / FALSE based on frequency source lock	TRUE / FALSE based on Frequency Source lock	(Note 1)	TRUE / FALSE based on frequency source lock	TRUE / FALSE based on Frequency source lock
currentUtcOffset	As per PTP	Last known UTC offset	(Note 1)	Last known UTC offset	Last known UTC offset (Note 2)
grandmasterPriority1	128 (default)	128 (default)	(Note 1)	128 (default)	128 (default)
grandmasterClockQuality.clockClass	248	Implementation specific, generally previous state. 135/165/248	(Note 1)	135	165
grandmasterClockQuality.clockAccuracy	Unknown (0xFE)	Unknown (0xFE)	(Note 1)	Unknown (0xFE)	Unknown (0xFE)
grandmasterClockQuality.offsetScaledLogVariance	0xFFFF (default)	0xFFFF (default)	(Note 1)	0xFFFF (default)	0xFFFF (default)
grandmasterPriority2	Configured priority2 of the T-BC/T-BC-P/T-BC-A	Configured priority2 of the T-BC/T-BC-P/T-BC-A	(Note 1)	Configured priority2 of the T-BC/T-BC-P/T-BC-A	Configured priority2 of the T-BC/T-BC-P/T-BC-A
grandmasterIdentity	Local clockId of the T-BC/T-BC-P/T-BC-A	Local clockId of the T-BC/T-BC-P/T-BC-A	(Note 1)	Local clockId of the T-BC/T-BC-P/T-BC-A	Local clockId of the T-BC/T-BC-P/T-BC-A
stepsRemoved	0	0	Received stepsRemoved +1 (Note 6)	0	0
timeSource	INT_OSC (0xA0)	INT_OSC (0xA0)	(Note 1)	INT_OSC (0xA0)	INT_OSC (0xA0)
synchronizationUncertain (header.flagField)	TRUE (Note 5)	TRUE	(Note 4)	(Note 4)	(Note 4)

NOTE 1 – The value sent in the *Announce* message corresponds to the value of the current grandmaster or time interface (as per [ITU-T G.8272] Appendix III) in case T-BC/T-BC-P/T-BC-A has selected a virtual port as the best timeTransmitter.

NOTE 2 – Refer to Table A.8 of [ITU-T G.8275.1] or Table A.6 of [ITU-T G.8275.2].

NOTE 3 – Valid UTC offset is one advertised by timeTransmitter with currentUtcOffsetValid value TRUE. In case there is no such value available, either default initializing UTC offset or one advertised by timeTransmitter with currentUtcOffsetValid as false can be used.

NOTE 4 – The value sent in the *Announce* message corresponds to the value received from the current parent clock or as defined in Annex D.

NOTE 5 – Or as defined in Annex D.

NOTE 6 – Or an implementation may send zero if the T-BC is locked to an embedded PRTC. (Refer to [IEEE 1588] clause 8.2.2.2 currentDS.stepsRemoved)

## Appendix IX

### Considerations on the use of [IEEE 1588-2019]

(This appendix does not form an integral part of this Recommendation.)

As per clause 19 in [IEEE 1588-2019], an [IEEE 1588-2019] compliant implementation is fully interoperable with an [IEEE 1588-2008] compliant version, provided that no new [IEEE 1588-2019] options are used.

There are a few minor additions in the precision time protocol (PTP) header specified by [IEEE 1588-2019], on bits that were earlier reserved: the `minorVersionPTP` and the `minorSdoId`. In this respect, the following apply for the telecom profiles:

- for an [IEEE 1588-2008] compliant implementation, on transmit these fields are reserved and are set to zero.
- for an [IEEE 1588-2019] compliant implementation, on transmit for these fields the `minorVersionPTP` is set to 1 and the `minorSdoId` is set to zero.
- for an [IEEE 1588-2008] compliant implementation, on receive these fields are reserved and ignored.
- for an [IEEE 1588-2019] compliant implementation, on receive these fields are not ignored, but are properly handled according to the value.

## Appendix X

### Flexible synchronization network based on cnPRTC

(This appendix does not form an integral part of this Recommendation.)

Mobile networks are critical infrastructure; they must be protected to overcome risks due to improper timing and synchronization. The coherent network PRTC (cnPRTC) architecture itself is a very resilient system and can overcome many threats, hazards, or disruptions even if they occur over an extended time. Specific situations with unavailability of timing and synchronization sources or limited network availability may require the flexibility of the synchronization network architecture. A re-configuration may be needed depending on the specific situation.

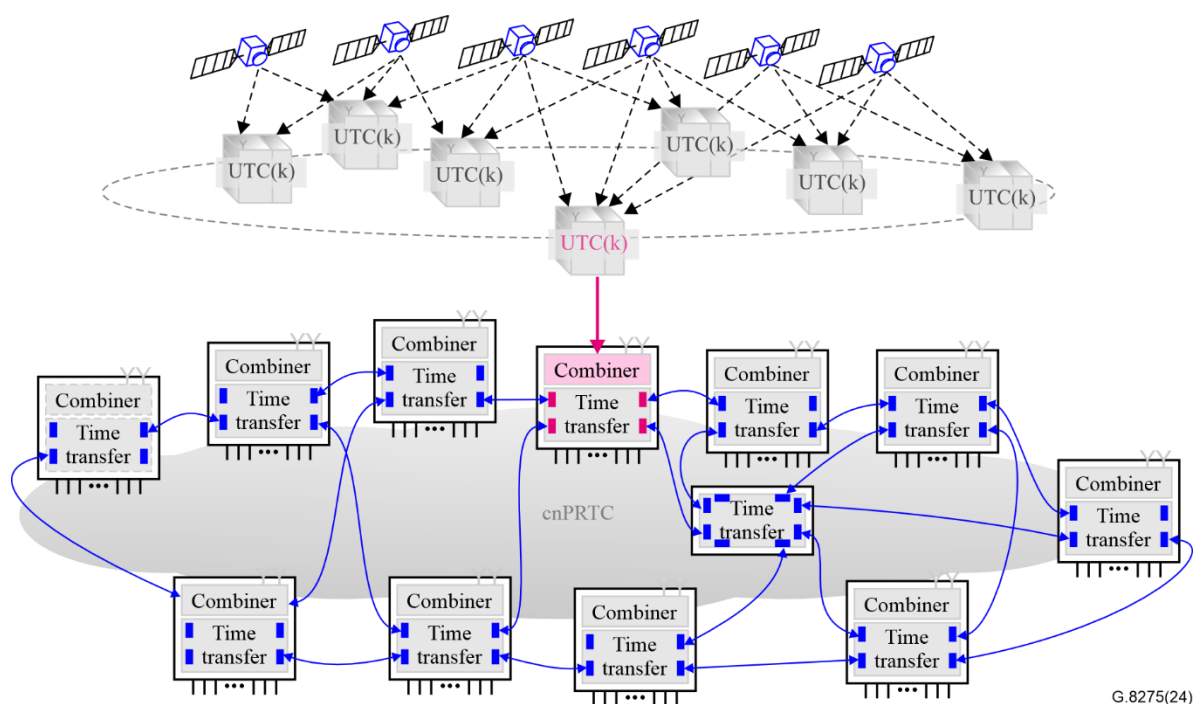
With coordinated universal time UTC(k) insertion at one or more cnPRTC clock combiners, the entire cnPRTC architecture becomes more flexible. For example, the neighbouring cnPRTC nodes could use the signals coming from cnPRTC nodes with UTC(k) insertion with higher priority by configuration.

Upon operational request, parts of the system could be reconfigured in a hierarchical structure, still maintaining the resilience of a cnPRTC. In an emergency, the entire system could be reconfigured as fully hierarchical.

#### A few examples follow:

- (1) cnPRTC architecture, using UTC(k) at one location

Figure X.1 shows a cnPRTC architecture, using one UTC(k) at one location. The red line is used to indicate the UTC(k) connection in the figure; the blue lines refer to regular cnPRTC operation. In this example, only one local cnPRTC system is set to UTC(k).

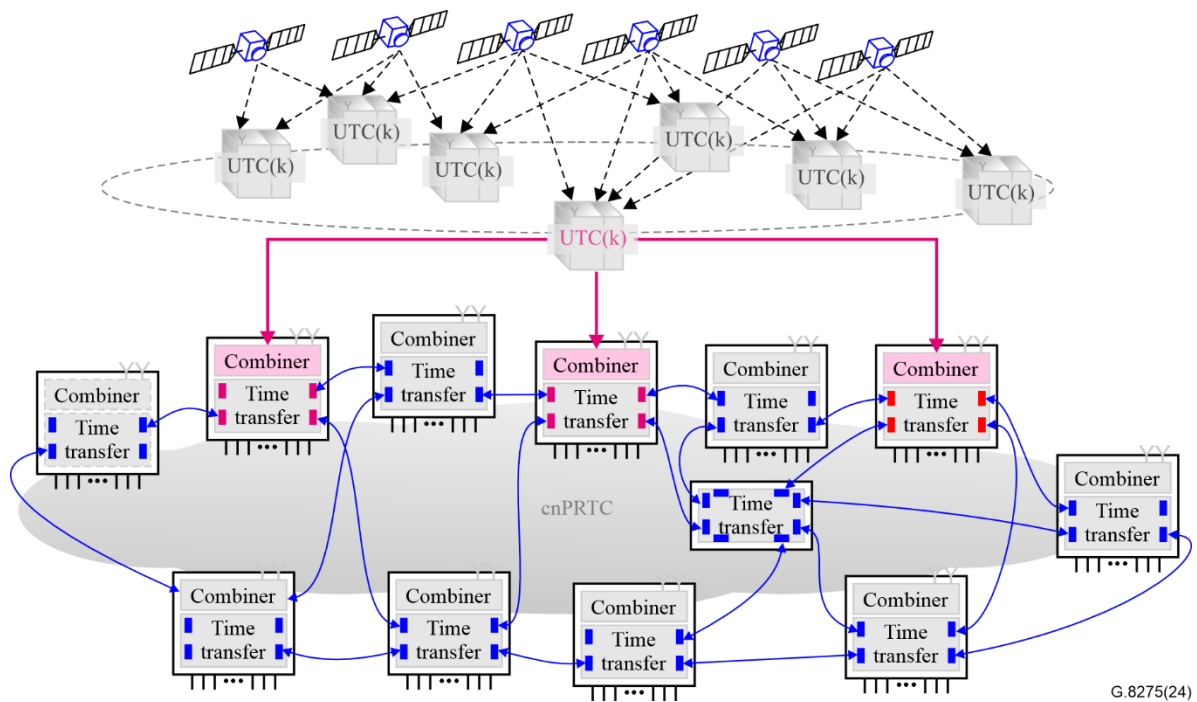


**Figure X.1 – cnPRTC architecture, using actively one UTC(k) at one location**

- (2) cnPRTC architecture, using UTC(k) at three locations

Figure X.2 shows a cnPRTC architecture using one UTC(k) at three locations. In this case, one local cnPRTC system is set to UTC(k). The red lines indicate UTC(k) connections and the blue lines indicate regular cnPRTC operation. For the cnPRTC system in the middle, it is a local UTC(k) source.

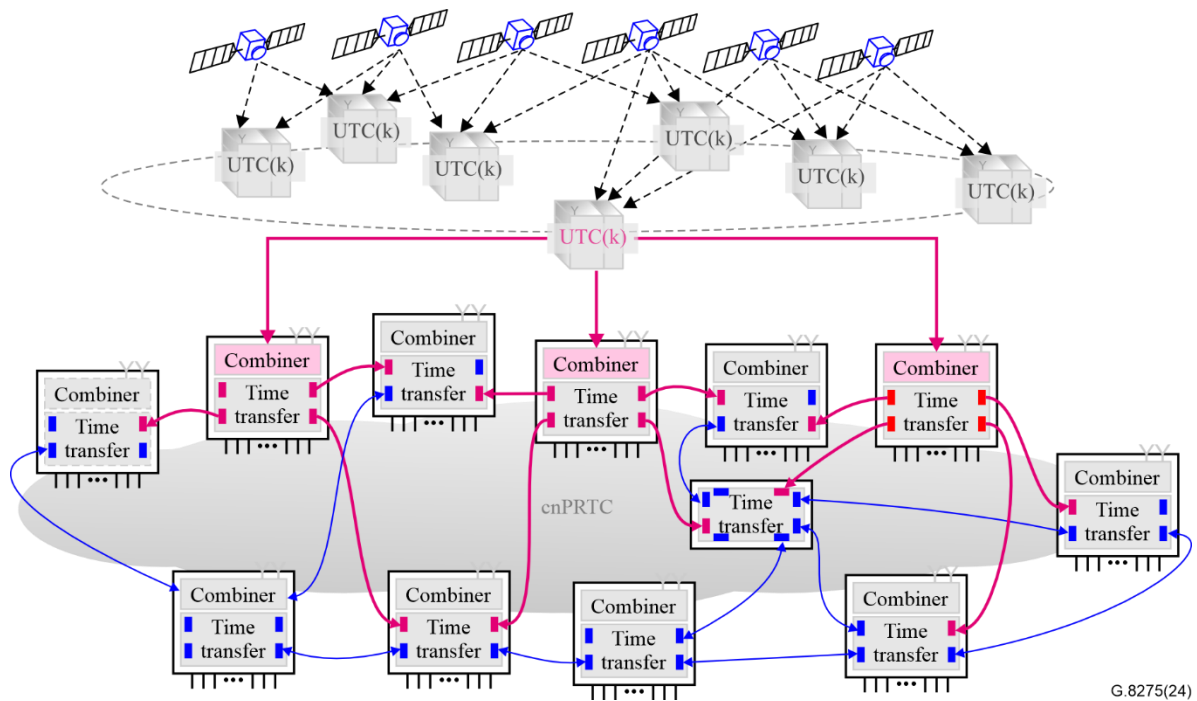
For the other two, it is via remote high-accuracy time transfer according to [ITU-T G.8271.1], which is specified with a maximum time error of 1 ns (Class B).



**Figure X.2 – cnPRTC architecture with three UTC insertion nodes as an example**

- (3) cnPRTC architecture, using UTC(k) at three locations for active further hierarchical synchronization

Figure X.3 shows a cnPRTC architecture, as before, using one UTC(k) actively at three locations. In addition, a section is configured for further hierarchical distribution.



**Figure X.3 – cnPRTC architecture with three UTC insertion nodes with further hierarchical synchronization**



- (4) In the case of massive primary source and / or network problems, the theoretical end point of such a reconfiguration could be a full hierarchical structure for the reachable part of the network. This would be at the expense of cnPRTC resilience.

## Appendix XI

### Information that can be used in the analysis of the performance monitoring data

(This appendix does not form an integral part of this Recommendation.)

When analysing the PM data specified in Annex F of this Recommendation, there is some additional information that is typically also available in the device (e.g., because related to standard SyncPHY and PTP datasets) and could allow a more complete and accurate correlation analysis.

Some of this information could be collected periodically (e.g., at the same time when the performance monitoring data is collected) or when some event happens (e.g., alarms).

As an example, the information from the defaultDS can provide important details on the characteristics of the PTP clock itself (e.g., deviceType, profileIdentifier clockIdentity, clockClass, etc.). Information from the currentDS and parentDS, can provide details on the reference (being tested), e.g., grandmasterIdentity, grandmasterClockQuality, stepsRemoved. From the portDS it is possible to get information on the state of the port (portState).

How some of this information changes over time (e.g., changes in the grandmasterIdentity, stepsRemoved) can be compared with changes in the PM data happening at the same time.

Additional datasets outside PTP are required to provide information on a non-PTP reference for the clock, e.g., local GNSS (when this is not modelled via a virtual PTP port).

How synchronization information outside PTP is handled is for further study (e.g., type of references being used as candidate synchronization reference, active reference, etc.).

SyncPHY dataset from [ITU-T G.781] Annex B, is also relevant as it provides information on the characteristics of the physical layer reference and this can have an important role on the overall clock performance (e.g., clock identity of the SyncE master from the parentDS.systemClockSourceID or Quality level from the parentDS.systemClockSourceQL).

## Appendix XII

### Updated terminology for PTP clocks and PTP profiles

(This appendix does not form an integral part of this Recommendation.)

The terminology related to partial timing support (PTP) clocks and PTP profiles has been revised based on [b-IEEE Std 1588g]. Some documents may still present the legacy terms. The following table summarizes the application of [b-IEEE Std 1588g] to the terms used in the ITU-T related Recommendations and that can be as a reference when legacy documents are used.

**Table XII.1 – TimeTransmitter-related terms**

<b>Legacy terminology</b>	<b>New terminology</b>
master	timeTransmitter
Master	TimeTransmitter
MASTER	TIME_TRANSMITTER
Abbreviation for master	TT
Abbreviation for packet master	pTT
BMCA	BTCA

**Table XII.2 – TimeReceiver-related terms**

<b>Legacy terminology</b>	<b>New terminology</b>
slave	timeReceiver
Slave	TimeReceiver
SLAVE	TIME_RECEIVER
Abbreviation for slave	TR
Abbreviation for packet slave	pTR

## Bibliography

- [b-ITU-T G.781] Recommendation ITU-T G.781 (2024), *Synchronization layer functions for frequency synchronization based on the physical layer.*
- [b-ITU-T G.812] Recommendation ITU-T G.812 (2004), *Timing requirements of slave clocks suitable for use as node clocks in synchronization networks.*
- [b-ITU-T G.8272.1] Recommendation ITU-T G.8272.1 (2024), *Timing characteristics of enhanced primary reference time clocks.*
- [b-ITU-T G.8272.2] Recommendation ITU-T G.8272.2 (2024), *Timing characteristics of coherent network primary reference time clocks.*
- [b-ITU-T G.8273.2] Recommendation ITU-T G.8273.2/Y.1368.2 (2023), *Timing characteristics of telecom boundary clocks and telecom time synchronous clocks for use with full timing support from the network.*
- [b-ITU-T G.8273.4] Recommendation ITU-T G.8273.4/Y.1368.4 (2020), *Timing characteristics of telecom boundary clocks and telecom time slave clocks for use with partial timing support from the network.*
- [b-IEEE 802.3] IEEE 802.3-2022 – *IEEE Standard for Ethernet.*  
<<https://ieeexplore.ieee.org/document/9844436>>
- [b-IEEE Std 1588g] Amendment to IEEE Std 1588g-2022, *IEEE Standard for a Precision Clock Synchronization Protocol for Networked Measurement and Control Systems Amendment 2: Master-Slave Optional Alternative Terminology.*  
<<https://standards.ieee.org/ieee/1588g/10478/>>



## SERIES OF ITU-T RECOMMENDATIONS

Series A	Organization of the work of ITU-T
Series D	Tariff and accounting principles and international telecommunication/ICT economic and policy issues
Series E	Overall network operation, telephone service, service operation and human factors
Series F	Non-telephone telecommunication services
<b>Series G</b>	<b>Transmission systems and media, digital systems and networks</b>
Series H	Audiovisual and multimedia systems
Series I	Integrated services digital network
Series J	Cable networks and transmission of television, sound programme and other multimedia signals
Series K	Protection against interference
Series L	Environment and ICTs, climate change, e-waste, energy efficiency; construction, installation and protection of cables and other elements of outside plant
Series M	Telecommunication management, including TMN and network maintenance
Series N	Maintenance: international sound programme and television transmission circuits
Series O	Specifications of measuring equipment
Series P	Telephone transmission quality, telephone installations, local line networks
Series Q	Switching and signalling, and associated measurements and tests
Series R	Telegraph transmission
Series S	Telegraph services terminal equipment
Series T	Terminals for telematic services
Series U	Telegraph switching
Series V	Data communication over the telephone network
Series X	Data networks, open system communications and security
Series Y	Global information infrastructure, Internet protocol aspects, next-generation networks, Internet of Things and smart cities
Series Z	Languages and general software aspects for telecommunication systems