



INTERNATIONAL TELECOMMUNICATION UNION

CCITT

THE INTERNATIONAL
TELEGRAPH AND TELEPHONE
CONSULTATIVE COMMITTEE

G.961

(11/1988)

SERIES G: TRANSMISSION SYSTEMS AND MEDIA,
DIGITAL SYSTEMS AND NETWORKS

Digital networks, digital sections and digital line systems –
Digital section and digital transmission systems
for customer access

**Digital transmission system on metallic local
lines for ISDN basic rate access**

Reedition of CCITT Recommendation G.961 published in
Blue Book, Fascicle III.5 (1989)

NOTES

- 1 CCITT Recommendation G.961 was published in Fascicle III.5 of the *Blue Book*. This file is an extract from the *Blue Book*. While the presentation and layout of the text might be slightly different from the *Blue Book* version, the contents of the file are identical to the *Blue Book* version and copyright conditions remain unchanged (see below).
- 2 In this Recommendation, the expression “Administration” is used for conciseness to indicate both a telecommunication administration and a recognized operating agency.

Recommendation G.961

DIGITAL TRANSMISSION SYSTEM ON METALLIC LOCAL LINES FOR ISDN BASIC RATE ACCESS

(Melbourne, 1988)

1 General

1.1 Scope

This Recommendation covers the characteristics and parameters of a digital transmission system at the network side of the NT1 to form part of the digital section for the ISDN basic rate access.

The system will support the

- full duplex;
- bit sequence independent

transmission of two B-channels and one D-channel as defined in Recommendation I.412 and the supplementary functions of the digital section defined in Recommendation I.603 for operation and maintenance.

The terminology used in this Recommendation is very specific and not contained in the relevant terminology Recommendations. Therefore Annex B to Recommendation G.960 provides a number of terms and definitions used in this Recommendation.

1.2 Definition

Figure 1/G.961 shows the boundaries of the digital transmission system in relation to the digital section.

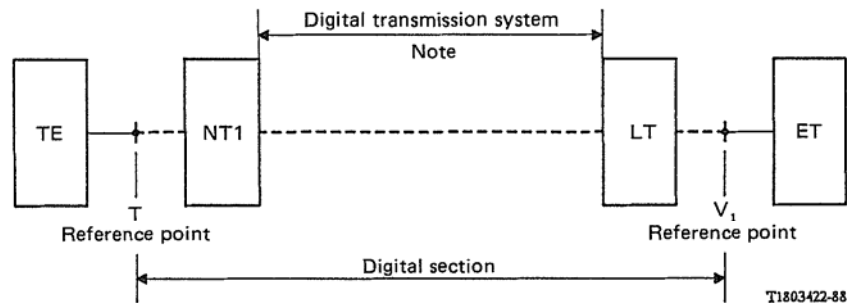

Note – In this Recommendation digital transmission system refers to a line system using metallic lines. The use of one intermediate regenerator may be required.

FIGURE 1/G.961

Digital section and transmission system boundaries

The concept of the digital section is used in order to allow a functional and procedural description and a definition of the network requirements. Note that the reference points T and V₁ are not identical and therefore the digital section is not symmetric.

The concept of a digital transmission system is used in order to describe the characteristics of an implementation, using a specific medium, in support of the digital section.

1.3 Objectives

Considering that the digital section between the local exchange and the customer is one key element of the successful introduction of ISDN into the network the following requirements for the specification have been taken into account:

- to meet the error performance specified in Recommendation G.960;
- to operate on existing 2-wire unloaded lines, open wires being excluded;

- the objective is to achieve 100% cable fill for ISDN basic access without pair selection, cable rearrangements or removal of bridged taps (BT) which exist in many networks;
- the objective to be able to extend ISDN basic access provided services to the majority of customers without the use of regenerators. In the remaining few cases special arrangements may be required;
- coexistence in the same cable unit with most of the existing services like telephony and voice band data transmission;
- various national regulations concerning EMI should be taken into account;
- power feeding from the network under normal or restricted conditions via the basic access shall be provided where the Administration provides this facility;
- the capability to support maintenance functions shall be provided.

1.4 Abbreviations

A number of abbreviations are used in this Recommendation. Some of them are commonly used in the ISDN reference configuration while others are created only for this Recommendation. The last one is given in the following:

BER	bit error ratio
BT	bridged tap
CISPR	Comité international spécial de perturbation radioélectrique (now part of IEC)
CL	control channel of the line system
ECH	echo cancellation
EMI	electro-magnetic interference
DLL	digital local line
DTS	digital transmission system
NEXT	near-end crosstalk
PSL	power sum loss
TCM	time compression multiplex
UI	unit interval

2 Functions

Figure 2/G.961 shows the functions of the digital transmission system on metallic local lines.

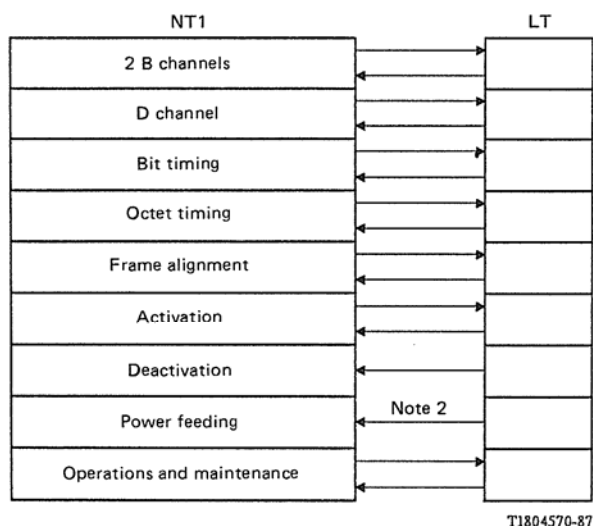

Note 1 – The optional use of one regenerator must be foreseen.

Note 2 – This function is optional.

FIGURE 2/G.961

Functions of the digital transmission system

2.1 *B-channel*

This function provides, for each direction of transmission, two independent 64 kbit/s channels for use as B-channels (as defined in Recommendation I.412).

2.2 *D-channel*

This function provides, for each direction of transmission, one D-channel at a bit rate of 16 kbit/s, (as defined in Recommendation I.412).

2.3 *Bit timing*

This function provides bit (signal element) timing to enable the receiving equipment to recover information from the aggregate bit stream. Bit timing for the direction NT1 to LT shall be derived from the clock received by the NT1 from the LT.

2.4 *Octet timing*

This function provides 8 kHz octet timing for the B-channels. It shall be derived from frame alignment.

2.5 *Frame alignment*

This function enables the NT1 and the LT to recover the time division multiplexed channels.

2.6 *Activation from LT or NT1*

This function restores the Digital Transmission system (DTS) between the LT and NT1 to its normal operational status. Procedures required to implement this function are described in § 6 of this Recommendation.

Activation from the LT could apply to the DTS only or to the DTS plus the customer equipment. In case the customer equipment is not connected, the DTS can still be activated.

Note – The functions required for operation and maintenance of the NT1 and one regenerator (if required) and for some activation/deactivation procedures are combined in one transport capability to be transmitted along with the 2B + D-channels. This transport capability is named the CL-channel.

2.7 *Deactivation*

This function is specified in order to permit the NT1 and the regenerator (if it exists) to be placed in a low power consumption mode or to reduce intrasystem crosstalk to other systems. The procedures and exchange of information are described in § 6 of this Recommendation. This deactivation should be initiated only by the exchange (ET). See Note in § 2.6.

2.8 *Power feeding*

This optional function provides for remote power feeding of one regenerator (if required) and NT1. The provision of wetting current is recommended.

Note – The provision of line feed power to the user-network interface, normal or restricted power feeding as defined in Recommendation I.430 is required by some Administrations.

2.9 Operations and maintenance

This function provides the recommended actions and information described in Recommendation I.603.

The following categories of functions have been identified:

- maintenance command (e.g., loopback control in the regenerator or the NT1);
- maintenance information (e.g., line errors);
- indication of fault conditions;
- information regarding power feeding in NT1.

See Note in § 2.6.

3 Transmission medium

3.1 Description

The transmission medium over which the digital transmission system is expected to operate, is the local line distribution network.

A local line distribution network employs cables of pairs to provide services to customers.

In a local line distribution network, customers are connected to the local exchange via local lines.

A metallic local line is expected to be able to simultaneously carry bi-directional digital transmission providing ISDN basic access between LT and NT1.

To simplify the provision of ISDN basic access, a digital transmission system must be capable of satisfactory operation over the majority of metallic local lines without requirement of any special conditioning. Maximum penetration of metallic local lines is obtained by keeping ISDN requirements at a minimum.

In the following, the term Digital Local Line (DLL) is used to describe a metallic local line that meets minimum ISDN requirements.

3.2 Minimum ISDN requirements

- a) No loading coils;
- b) No open wires;
- c) When BTs are present, some restrictions may apply. Typical allowable BT configurations are discussed in § 4.2.1.

3.3 DLL physical characteristics

In addition to satisfying the minimum ISDN requirements, a DLL is typically constructed of one or more twisted-pair segments that are spliced together. In a typical local line distribution network, these twisted-pair segments occur in different types of cables as described in Figure 3/G.961.

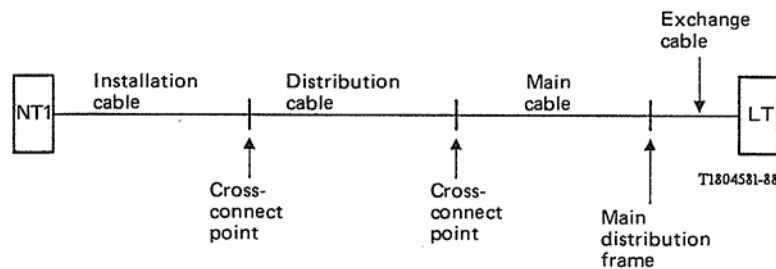

FIGURE 3/G.961

DLL physical model

3.4 DLL electrical characteristics

3.4.1 Insertion loss

The DLL will have non-linear loss versus frequency characteristic. For any DLL of a particular gauge mix, with no BTs and with an insertion loss of x dB at 80 kHz, the typical behaviour of its insertion loss versus frequency is depicted in Figure 4/G.961.

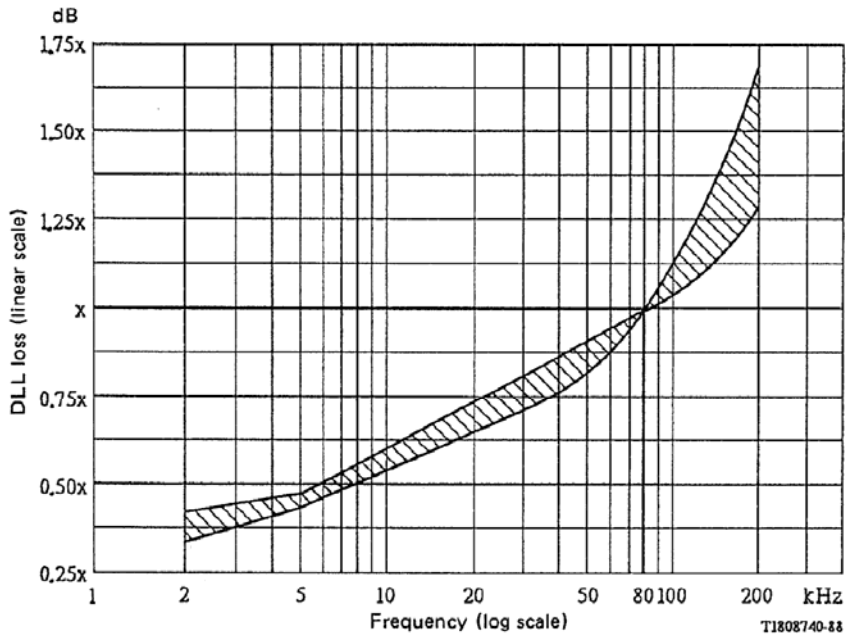

Note — The maximum value of x ranges from 37 dB to 50 dB at 80 kHz. The minimum value could be close to zero.

FIGURE 4/G.961

Typical insertion loss characteristic without presence of BTs

3.4.2 *Group delay*

Typical ranges of values of DLL group delay as a function of frequency are shown in Figure 5/G.961.

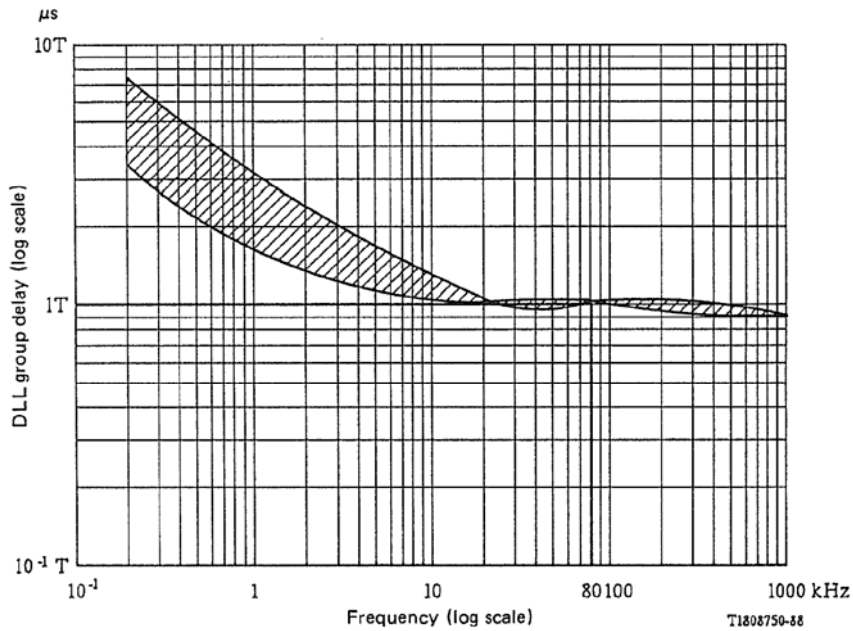

Note — The maximum value of one-way group delay (T) ranges from 30 to 60 microseconds at 80 kHz.

FIGURE 5/G.961

Typical group delay characteristic

3.4.3 *Characteristic impedance*

Typical ranges of values of the real and imaginary parts of the characteristic impedance of twisted pairs in different types of cables are shown in Figure 6/G.961.

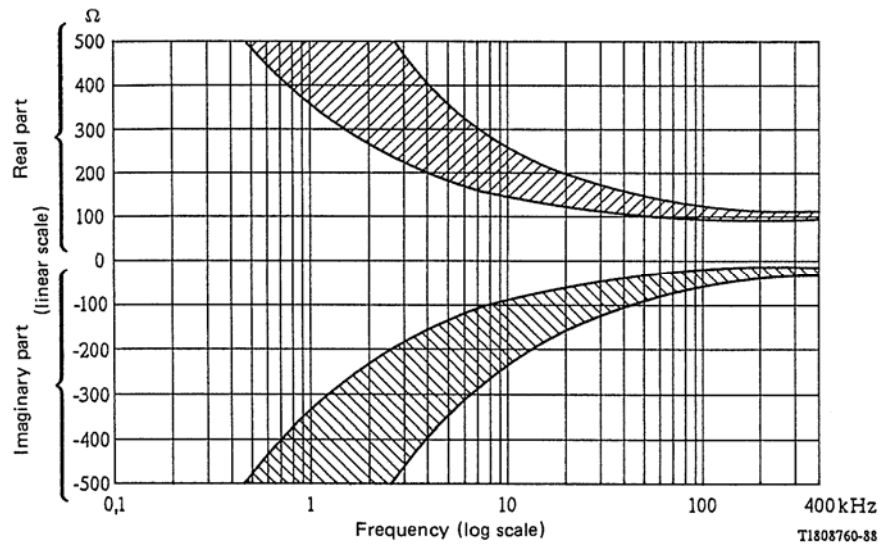

FIGURE 6/G.961

Typical ranges of values of real and imaginary parts of characteristic impedance

3.4.4 *Near-end crosstalk (NEXT)*

The DLL will have finite crosstalk coupling loss to other pairs sharing the same cable. Worst-case NEXT power sum loss (PSL) varies from 44 to 57 dB at 80 kHz (refer to § 4.2.2).

The DLL loss and PSL ranges have been independently specified. However, it is not required that all points in both ranges be satisfied simultaneously. A combined DLL loss/PSL representation is shown in Figure 7/G.961 to define the combined range of operation.

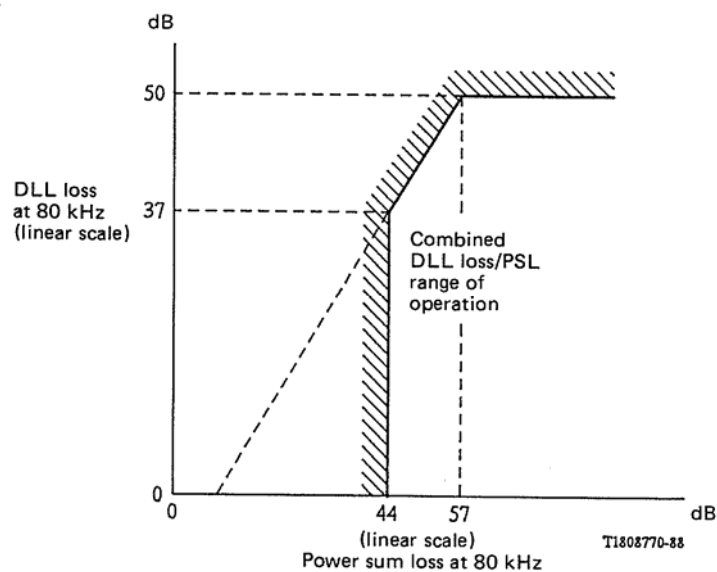

FIGURE 7/G.961

Combined representation of DLL loss/PSL range of operation

3.4.5 Unbalance about earth

The DLL will have finite balance about earth. Unbalance about earth is described in terms of longitudinal conversion loss. Worst-case values are shown in Figure 8/G.961.

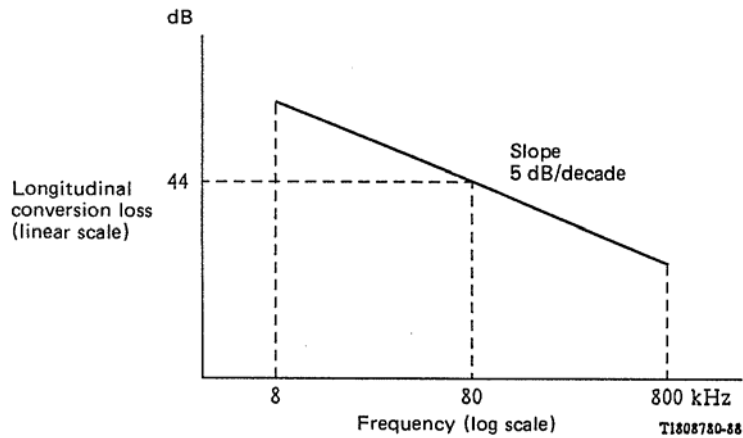

FIGURE 8/G.961

Worst-case longitudinal conversion loss versus frequency

3.4.6 Impulse noise

The DLL will have impulse noise resulting from other systems sharing the same cable as well as from other sources.

4 System performance

4.1 Performance requirements

Performance limits for the digital section are specified in § 4 of Recommendation G.960. The digital transmission system performance must be such that these performance limits are met. For that purpose, a digital transmission system is required to pass specific laboratory performance tests that are defined in the next sections.

4.2 Performance measurements

Laboratory performance measurement of a particular digital transmission system requires the following preparations:

- a) definition of a number of DLL models to represent physical and electrical characteristics encountered in local line distribution networks;
- b) simulation of the electrical environment caused by finite crosstalk coupling loss to other pairs in the same cable;
- c) simulation of the electrical environment caused by impulse noise;
- d) specification of laboratory performance tests to verify that the performance limits referred to in § 4.1 will be met.

4.2.1 DLL physical models

For the purposes of laboratory testing of performance of a digital transmission system providing ISDN basic access, some models representative of DLLs to be encountered in a particular local line distribution network are required. The maximum loss in each model is optionally set between 37 and 50 dB at 80 kHz to satisfy requirements of the particular network. Similarly, the lengths of BTs are optionally set within the range defined in Figure 9/G.961.

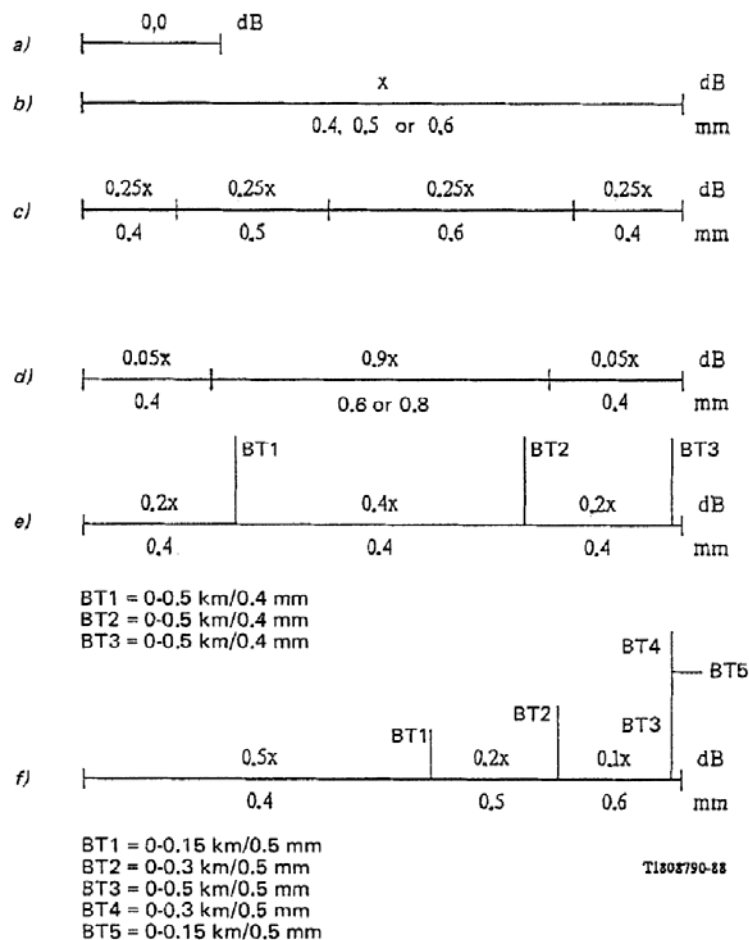

Note 1 – The value of x varies from 37 to 50 dB at 80 kHz.

Note 2 – Equivalent gauges can be used. For example 0.6 mm is equivalent to AWG 22. AWG stands for American Wire Gauge.

FIGURE 9.G.961

DLL physical models for laboratory testing

4.2.2 Intrasystem crosstalk modelling

4.2.2.1 Definition of intrasystem crosstalk

Crosstalk noise in general results due to finite coupling loss between pairs sharing the same cable, especially those pairs that are physically adjacent. Finite coupling loss between pairs causes a vestige of the signal flowing on one DLL (disturber DLL) to be coupled into an adjacent DLL (disturbed DLL). This vestige is known as crosstalk noise. Near-end crosstalk (NEXT) is assumed to be the dominant type of crosstalk. Intrasystem NEXT or self NEXT results when all pairs interfering with each other in a cable carry the same digital transmission system. Intersystem NEXT results when pairs carrying different digital transmission systems interfere with each other. Definition of intersystem NEXT is not part of this Recommendation.

Intrasystem NEXT noise coupled into a disturbed DLL from a number of DLL disturbers is represented as being due to an equivalent single disturber DLL with a coupling loss versus frequency characteristic known as PSL. Worst-case PSL encountered in a local line distribution network is defined in Figure 10/G.961. All DLLs are assumed to have fixed resistance terminations of R_0 ohms. The range of R_0 is 110 to 150 ohms.

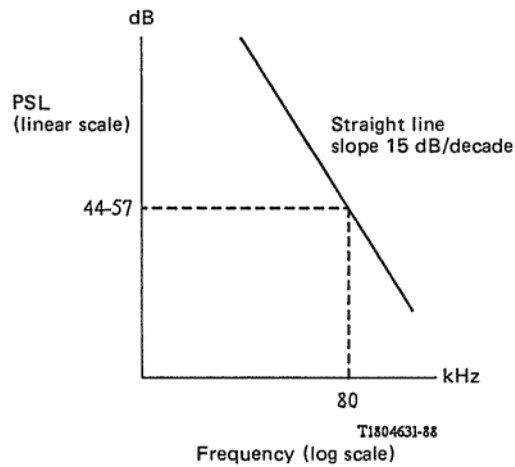

FIGURE 10/G.961

Worst-case power sum loss (PSL)

4.2.2.2 *Measurement arrangement*

Simulation of intrasystem NEXT noise is necessary for performance testing of digital transmission systems. Intrasystem noise coupled into the receiver of the disturbed DLL depends on:

- a) Power spectrum of the transmitted digital signal. The power spectrum is a function of the line code and the transmit filter.
- b) Spectrum shaping due to the PSL characteristic of Figure 10/G.961.

The measurement arrangement of Figure 11/G.961 can be used for testing of performance with intrasystem crosstalk noise.

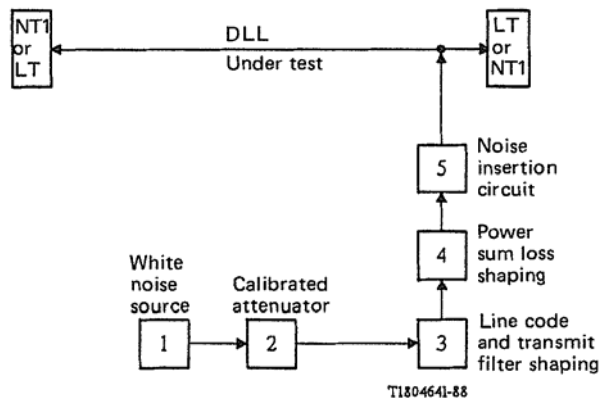

FIGURE 11/G.961

Crosstalk noise simulation and testing

The measurement arrangement in Figure 11/G.961 is described in the following:

- a) Box 1 represents a white noise source of constant spectral density. Spectrum is flat from 100 Hz to 500 kHz rolling off afterwards at a rate ≥ 20 dB/decade.
- b) Box 2 is a variable attenuator.
- c) Box 3 is a filter that shapes the power spectrum to correspond to a particular line code and a particular transmit filter.
- d) Box 4 is a filter that shapes the power spectrum according to the PSL characteristic of Figure 10/G.961.

- e) Box 5 is a noise insertion circuit which couples the simulated crosstalk noise into the DLL without disturbing its performance. The insertion circuit therefore must be of sufficiently high output impedance relative to the magnitude of the characteristic impedance of the DLL under test. A value of $\geq 4.0 \text{ k}\Omega$ in the frequency range 0 to 1000 kHz is recommended.

Boxes 3, 4 and 5 in Figure 11/G.961 are conceptual. Dependent on the particular realization, they could possibly be combined into one circuit. The measurement arrangement in Figure 11/G.961 is calibrated according to the following steps:

- a) By terminating the output of Box 5 with a resistor of a value of $R_o/2$ ohm, and measuring the true r.m.s. (root-mean-square) voltage across it in a bandwidth extending from 100 Hz to over 500 kHz. The power dissipated in the $R_o/2$ resistor is 3 dB higher than the power coupled into the receiver of the DLL under test.
- b) The shape of the noise spectrum measured across the $R_o/2$ resistor should be within:
 - $\pm 1 \text{ dB}$ for values within 0 dB to 10 dB down from the theoretical peak;
 - $\pm 3 \text{ dB}$ for values within 10 dB to 20 dB down from the theoretical peak;
 for measurement purposes a resolution bandwidth of $\geq 10 \text{ kHz}$ is recommended.
- c) The peak factor of the noise voltage across the $R_o/2$ resistor should be ≥ 4 . This in turn fixes the dynamic range requirements of the circuits used in the measurement arrangement.

With the specified calibrated measurement arrangement, intrasystem crosstalk noise due to a worst-case PSL can be injected into the DLL under test while monitoring its performance. The noise level can be increased or decreased to determine positive or negative performance margins.

4.2.3 Impulse noise modelling

4.2.3.1 Definition of impulse noise

Impulse noise energy appears concentrated in random short time intervals during which it attains substantial levels. For the rest of the time impulse noise effects are negligible.

4.2.3.2 Measurement arrangement

Figure 12/G.961 shows a possible arrangement for impulse noise testing.

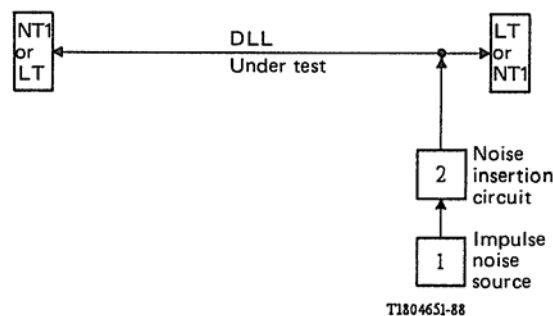
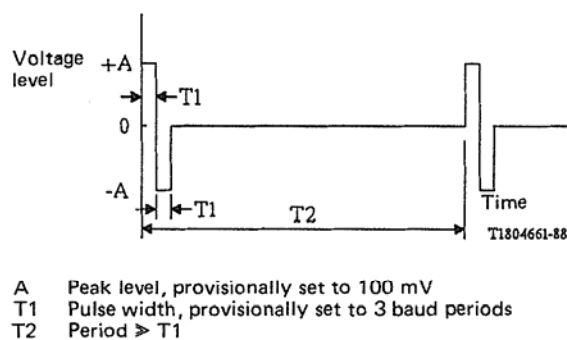

FIGURE 12/G.961

Impulse noise simulation and testing

The impulse noise source in Figure 12/G.961 is for further study. Two possible classes of impulse noise signals are described in the following:

- white noise of flat spectral density level of $5\text{-}10 \mu\text{V}/\sqrt{\text{Hz}}$ and a bandwidth > 4 times the Nyquist frequency of the particular system. The peak factor of the noise must be > 4 ;
- a particular waveform, as represented in Figure 13/G.961.



Note — In some local line distribution networks and as a national option, crosstalk noise performance tests are considered sufficient to evaluate a particular digital transmission system. In such cases proper DLL engineering rules are applied to guard against impulse noise.

FIGURE 13/G.961

Possible waveform to simulate impulse noise

4.2.4 *Performance tests*

Five types of tests are required to describe the overall performance of a particular digital transmission system to qualify it for operation over the local line distribution network modelled in this Recommendation.

4.2.4.1 *Dynamic range*

Dynamic range performance describes the ability of a particular digital transmission system to operate with received signals varying in level over a wide range. DLL models 1 and 2 in Figure 9/G.961 have a loss varying from very low (0 dB) to very high (37-50 dB at 80 kHz).

When testing with DLL models 1 and 2 in Figure 9/G.961, no errors should be observed in any 15 minutes (provisional) measuring interval when monitoring any B-channel.

Specification of data sequences to be used for this measurement are for further study.

4.2.4.2 *Immunity to echoes*

The remaining DLL models in Figure 9/G.961 are used to test performance of digital transmission systems in the presence of BTs and/or diameter changes.

In each model, no errors should be observed in any 15 minutes (provisional) measuring interval when monitoring any B-channel.

Specification of data sequences to be used for this measurement are for further study.

4.2.4.3 *Intrasystem crosstalk*

Using the crosstalk arrangement described in § 4.2.2.2 with simulated crosstalk noise injected in each DLL model in Figure 9/G.961 the observed bit error ratio (BER) should be $\leq 10^{-6}$ (provisional).

When BER measurements are performed in a B-channel, a measuring interval of at least 15 minutes (provisional) is required.

In each DLL model, performance margins are determined. Definition of a minimum positive performance margin is left for further study. This is required to account for additional DLL loss due to splices, and environmental effects (e.g. temperature change).

Specification of data sequences to be used for this measurement are for further study.

4.2.4.4 *Impulse noise*

For further study.

4.2.4.5 Longitudinal voltages induced from power lines

For further study.

5 Transmission method

The transmission system provides for duplex transmission on 2-wire metallic local lines. Duplex transmission shall be achieved through the use of ECHO CANCELLATION (ECH) or TIME COMPRESSION MULTIPLEX (TCM). With the ECH method, illustrated in Figure 14/G.961, the echo canceller produces a replica of the echo of the transmitted signal that is subtracted from the total received signal. The echo is the result of imperfect balance of the hybrid and impedance discontinuities in the line.

With the TCM or “burst mode” method, illustrated in Figure 15/G.961, transmissions on the DLL are separated in time (bursts). Blocks of bits (bursts) are sent alternatively in each direction. Bursts are passed through buffers at each transceiver terminal such that the bit stream at the input and output of the TCM transceiver terminal is continuous at the rate R. The bit rate on the line is required to be greater than 2R to provide for an idle interval between bursts which is necessary to allow for the transmission delay and transmitter/receiver turn-around (switching of S_n and S_e in Figure 15/G.961).

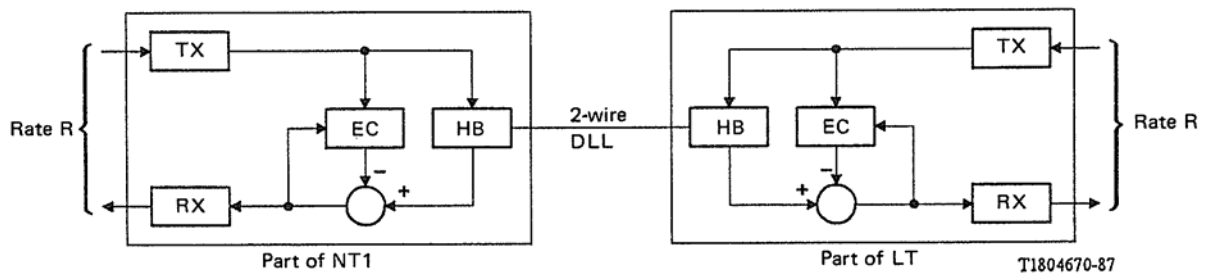
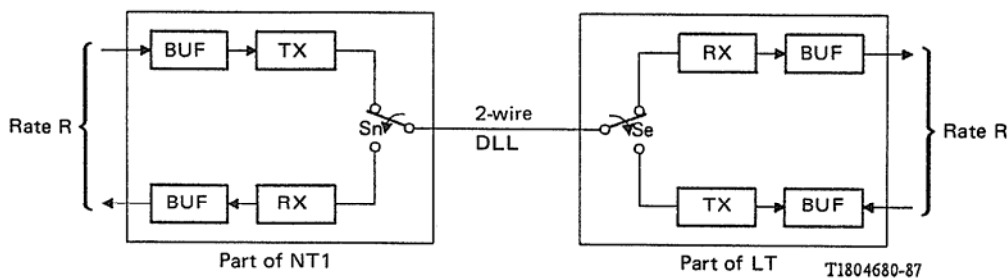

FIGURE 14/G.961

ECH method functional diagram



- TX Transmitter
- RX Receiver
- EC Echo canceller
- HB Hybrid
- BUF Buffer

FIGURE 15/G.961

TCM method functional diagram

6 Activation/deactivation

6.1 General

The functional capabilities of the activation/deactivation procedure are specified in Recommendation G.960. The transmission system has to meet the requirements specified in Recommendation G.960. In particular, it has to make provision to convey the signals defined in Recommendation G.960 which are required for the support of the procedures.

6.2 *Physical representation of signals*

The signals used in the digital transmission system are system dependent and can be found in Annex A and in the Appendices to this Recommendation.

7 **Operation and maintenance**

7.1 *Operation and maintenance functions*

The operation and maintenance functions in the digital transmission system using metallic local lines for the ISDN basic rate access, are defined in Recommendation G.960.

7.2 *CL channel*

7.2.1 **CL channel** *definition*

This channel is conveyed by the digital transmission system in both directions between LT and NT1. It is used to transfer information concerning operation, maintenance and activation/deactivation of the digital transmission system and of the digital section.

7.2.2 *CL channel requirements*

For further study.

The minimum number of functions (optional or mandatory) the CL channel should support is for further study.

7.3 *Transfer mode of operation and maintenance links*

For further study.

8 **Power feeding**

8.1 *General*

This section deals with power feeding of the NT1, one regenerator (if required), and the provision of power to the user-network interface according to Recommendation I.430 under normal and restricted conditions.

When activation/deactivation procedures are applied, power down modes at the NT1, regenerator (if required) and the LT are defined.

8.2 *Power feeding options*

Power feeding options under normal and restricted conditions are considered. For this purpose, a restricted condition is entered after failure of AC mains power at the NT1 location.

a) Power feeding of NT1 under normal conditions will be provided using one of the following options:

- AC mains powering;
- remote powering from the network (or via a regenerator, if required).

In both cases the NT1 may provide power to the user-network interface according to Recommendation I.430. This power is derived from AC mains or remotely from the network.

b) Power feeding of NT1 under restricted conditions, when provided, employs one of the following optional sources:

- back-up battery;
- remote powering from the network (or via a regenerator, if required).

In both cases the NT1 may provide power to the user-network interface according to Recommendation I.430.

Power feeding options are chosen to satisfy national regulations.

Two power feeding and recovery methods are possible and are described in Figure 16/G.961.

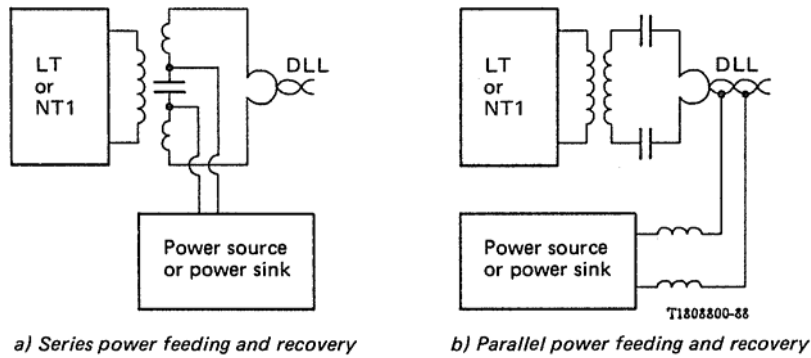

FIGURE 16/G.961

Power feeding and recovery methods

When no regenerator is present on the DLL connecting the LT and the NT1, for each case in Figure 16/G.961 the power source could be either a constant voltage source with current limiting or a constant current source with voltage limiting.

When a regenerator is present, both methods of power feeding and recovery in Figure 16/G.961 remain applicable. However, when a constant voltage source is used at the LT, the regenerator power sink is connected in parallel to the DLLs and when a constant current source is used at the LT, the regenerator power sink is connected in series with the DLLs. The resulting configurations are shown in Figure 17/G.961.

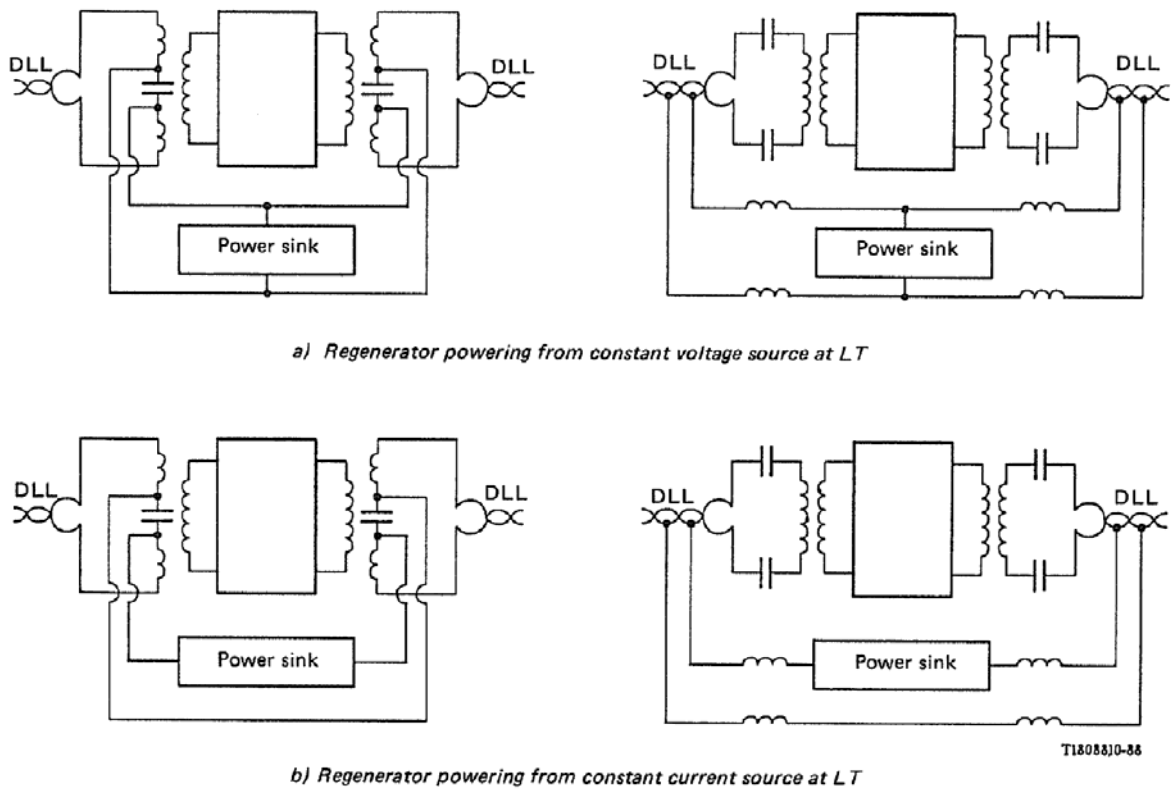

FIGURE 17/G.961

Powering at regenerator

8.4 *DLL resistance*

This parameter is a particular subject of the individual local network and therefore out of the scope of this Recommendation. Its maximum value depends on the LT output voltage, the power consumption of the NT1 and regenerator (if required) and the power feeding arrangement for the user-network interface.

8.5 *Wetting current*

The NT1 shall provide a DC termination to allow a minimum wetting current to flow (the value has to be defined) including the power down mode or in case of local power feeding of the NT1.

8.6 *LT aspects*

A current limitation for voltage source configuration or a voltage limitation for current source configuration is required. The values shall take into account the relevant IEC Publications and national safety regulations.

Short-term overload of the feeding current may be tolerated (charging condition of the capacitor of DC/DC converter in NT1).

8.7 *Power requirements of NT1 and regenerator*

8.7.1 *Power requirements of NT1*

- a) active state without powering of user-network interface: to be defined;
- b) active state including restricted powering of the user-network interface as defined in Recommendation I.430: to be defined;
- c) active state including normal powering of user-network interface as defined in Recommendation I.430: to be defined;
- d) power down mode: to be defined.

8.7.2 *Power requirements of regenerator*

For further study.

8.8 *Current transient limitation*

The rate of change of current drawn by the NT1 or regenerator from the network shall not exceed X mA/ μ s. The value of X is to be defined.

9 Environmental conditions

9.1 *Climatic conditions*

Climatograms applicable to the operation of NT1 and LT equipment in weather protected and non-weather protected locations can be found in IEC Publication 721-3. The choice of classes is under national responsibility.

9.2 *Protection*

9.2.1 *Isolation*

Isolation between various points at the NT1 can be identified:

- between line interface and T reference point;
- between line interface or T reference point and AC mains (this is generally defined in IEC Guide 105 and IEC Publication 950 but the test requirements may be different in various countries);
- between line interface and the protective ground of AC mains.

9.2.2 *Overvoltage protection*

- To conform with Recommendations K.12, K.20 for LT.
- To conform with Recommendations K.12, K.21 for NT1.

9.3 *Electromagnetic compatibility*

9.3.1 *Susceptibility, radiated and conducted emission levels for LT or NT1 equipment*

This is outside of the scope of this Recommendation. CISPR Publication 22 and national regulations have to be considered.

9.3.2 *Limitation of the output power to the line*

Due to limited longitudinal conversion loss of the line at high frequencies and the limitation of radiation according to CISPR Publication 22 and national regulations, the output power shall be limited. The specific values are outside the scope of this Recommendation.

ANNEX A

(to Recommendation G.961)

General structure for an Appendix on electrical characteristics

A.0 *Electrical characteristics*

Short general characterization of the digital transmission system.

Note – The content of this Annex is a guideline for the presentation of the description of the digital transmission systems and is not intended to constrain any of the systems which will be included.

A.1 *Line code*

For both directions of the transmission the line code is . . . And the coding scheme will be . . .

A.2 *Symbol rate*

The symbol rate is determined by the line code, the bit rate of the information stream and the frame structure. The symbol rate is . . . kbaud.

A.2.1 *Clock requirements*

A.2.1.1 *NT1 free running clock accuracy*

The accuracy of the free running clock in the NT1 shall be \pm . . . ppm.

A.2.1.2 *LT clock tolerance*

The NT1 and LT shall accept a clock accuracy from the ET of \pm . . . ppm.

A.3 *Frame structure*

The frame structure contains a frame word, N times $(2B + D)$ and a CL channel.

Frame word	N times $(2B + D)$	CL channel
------------	----------------------	------------

A.3.1 *Frame length*

The number N of $(2B + D)$ slots in one frame is . . .

A.3.2 *Bit allocation in direction LT-NT1*

In Figure A-1/G.931 the bit allocation is given.

TO BE PREPARED FOR EVERY SPECIFIC CASE

FIGURE A-1/G.961

Bit allocation in direction LT-NT1

A.3.3 *Bit allocation in direction NT1-LT*

In Figure A-2/G.961 the bit allocation is given.

TO BE PREPARED FOR EVERY SPECIFIC CASE

FIGURE A-2/G.961

Bit allocation in direction NT1-LT

A.4 *Frame word*

The frame word is used to allocate bit positions to the $2B + D + CL$ channels. It may, however, also be used for other functions.

A.4.1 *Frame word in direction LT-NT1*

The code for the frame word will be . . .

A.4.2 *Frame word in direction NT1-LT*

The code for the frame word will be . . .

A.5 *Frame alignment procedure*

A.6 *Multiframe*

To enable bit allocation of the CL channel in more frames next to each other a multiframe structure may be used. The start of the multiframe is determined by the frame word. The total number of frames in a multiframe is . . .

A.6.1 *Multiframe word in direction NT1-LT*

The multiframe will be identified by . . .

A.6.2 *Multiframe word in direction LT-NT1*

The multiframe will be identified by . . .

A.7 *Frame offset between LT-NT1 and NT1-LT frames*

The NT1 shall synchronize its frame on the frame received in the direction LT to NT1 and will transmit its frame with an offset.

A.8 *CL channel*

A.8.1 *Bit rate*

A.8.2 *Structure*

A.8.3 *Protocols and procedures*

A.9 *Scrambling*

Scrambling will be applied on 2B+D channels and the scrambling algorithm shall be as follows:

- In direction LT to NT1
- In direction NT1 to LT.

A.10 *Activation/deactivation*

Description of system activation/deactivation procedure including options that are supported and options that are not supported.

See also Recommendation G.960, § 5.

A.10.1 *Signals used for activation*

A list and definition of the signals used for activation/deactivation (SIGs).

- signals used for start-up (CL not available);
- bits in CL channel in an already established frame.

A.10.2 *Definition of internal timers*

A.10.3 *Description of the activation procedure* (based on arrow sequence for the error-free case)

- activation from the network side;
- activation from the user side.

A.10.4 *State transition table NT1 as a function of INFOs, SIGs, internal timers*

The description of loop backs and options supported is given in such a way that the minimum implementation may be clearly identified.

A.10.5 *State transition table LT as a function of FEs, SIGs, internal timers*

The description of loop backs and options supported is given in such a way that the minimum implementation may be clearly identified.

A.10.6 *Activation times*

See Recommendation G.960, §§ 5.5.1 and 5.5.2.

A.11 *Jitter*

Jitter tolerances are intended to ensure that the limits of Recommendation I.430 are supported by the jitter limits of the transmission system on local lines. The jitter limits given below must be satisfied regardless of the length of the local line and the inclusion of one regenerator, provided that they are covered by the transmission media characteristics (see § 3). The limits must be met regardless of the bit patterns in the B, D and CL channels.

A.11.1 *NT1 input signal jitter tolerance*

The NT1 shall meet the performance objectives with wander/jitter at the maximum magnitudes (J_1 , J_2) indicated in Figure A-3/G.961, for single jitter frequencies in the range of F_1 Hz to F_3 kHz ($F_3 = 1/4 F_6$, $F_6 =$ symbol rate frequency), superimposed on the test signal source. The NT1 shall also meet the performance objectives with wander per day of up to . . . UI peak-to-peak where the maximum rate of change of phase is . . . UI/hour.

A.11.2 *NT1 output jitter limitations*

With the wander/jitter as specified in § A.11.1 superimposed on the NT1 input signal, the jitter on the transmitted signal on the NT1 towards the network shall conform to the following:

- a) The jitter shall be equal to or less than . . . UI peak-to-peak and less than . . . UI r.m.s. when measured with a high-pass filter having a 20 dB/decade roll-off below $M \cdot F_2$ Hz ($M \cdot 1$).
- b) The jitter in the phase of the output signal relative to the phase of the input signal (from the network) shall not exceed . . . UI peak-to-peak or . . . UI r.m.s. when measured with a band-pass filter having a 20 dB/decade roll-off above $N \cdot F_2$ Hz ($N \cdot 2$) and a 20 dB/decade roll-off below $K \cdot F_k$ ($F_k \ll 1$). This requirement applies with superimposed jitter in the phase of the input signal as specified in § A.11.1 for single frequencies up to F_2 Hz.

A.11.3 *Test conditions for jitter measurements*

Due to bidirectional transmission on the 2-wire and due to severe intersymbol interference no well defined signal transitions are available at the NT1 2-wire point.

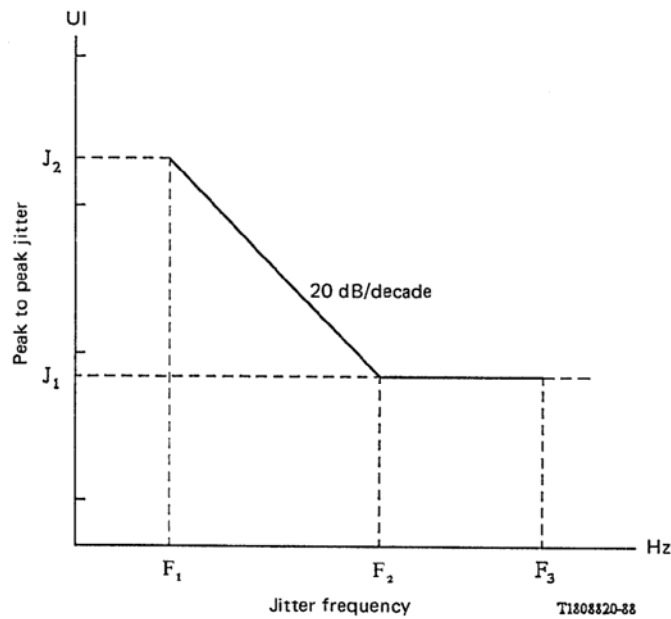

Note — Two possible solutions are proposed:

- a) A test point in the NT1 is provided to measure jitter with an undisturbed signal.
- b) A standard LT transceiver including an artificial local line is defined as a test instrument.

FIGURE A-3/G.961

Minimum tolerable jitter on NT1 input signal

A.12 *Transmitter output characteristics of NT1 and LT*

The following specifications apply with a load impedance of . . .

A.12.1 *Pulse amplitude*

The zero to peak nominal amplitude of the largest pulse shall be . . . V and the tolerance shall be \pm . . . %.

A.12.2 *Pulse shape*

The pulse shape shall meet the pulse mask of Figure . . .

A.12.3 *Signal power*

The average signal power shall be between . . . dBm and . . . dBm.

A.12.4 *Power spectrum*

The upper bound of the power spectral density shall be within the template in Figure . . .

A.12.5 *Transmitter signal nonlinearity*

This is a measure of the deviations from ideal pulse heights and the individual pulse nonlinearity.

The measurement method is for further study.

A.13 *Transmitter/receiver termination*

A.13.1 *Impedance*

The nominal input/output impedance looking toward the NT1 or LT respectively shall be . . .

A.13.2 *Return loss*

The return loss of the impedance shall be greater than shown in the template Figure . . .

A.13.3 *Longitudinal conversion loss*

The minimum longitudinal conversion loss shall be as follows:

. . . kHz . . . dB

. . . kHz . . . dB

APPENDIX 1

(to Recommendation G.961)

Electrical characteristics of an MMS 43 transmission system

I.1 *Line code*

For each direction of transmission the line code is a Modified Monitoring State Code mapping 4 bits into 3 ternary symbols with levels +, 0 or – (MMS 43). Details of the coding scheme are given in Figure I-1/G.961. Note that the numbers in the columns for each of the 4 alphabets S1 . . . S4 give the numbers of the alphabet to be used for the coding of the next block of 4 bits. The bits and symbols standing left are those transmitted or received first.

	S1	S2	S3	S4
0001	0 – + 1	0 – + 2	0 – + 3	0 – + 4
0111	– 0 + 1	– 0 + 2	– 0 + 3	– 0 + 4
0100	– + 0 1	– + 0 2	– + 0 3	– + 0 4
0010	+ – 0 1	+ – 0 2	+ – 0 3	+ – 0 4
1011	+ 0 – 1	+ 0 – 2	+ 0 – 3	+ 0 – 4
1110	0 + – 1	0 + – 2	0 + – 3	0 + – 4

1001	+ – + 2	+ – + 3	+ – + 4	– – – 1
0011	0 0 + 2	0 0 + 3	0 0 + 4	– – 0 2
1101	0 + 0 2	0 + 0 3	0 + 0 4	– 0 – 2
1000	+ 0 0 2	+ 0 0 3	+ 0 0 4	0 – – 2
0110	– + + 2	– + + 3	– + + 2	– – + 3
1010	+ + – 2	+ + – 3	+ – – 2	+ – – 3
1111	+ + 0 3	0 0 – 1	0 0 – 2	0 0 – 3
0000	+ 0 + 3	0 – 0 1	0 – 0 2	0 – 0 3
0101	0 + + 3	– 0 0 1	– 0 0 2	– 0 0 3
1100	+ + + 4	– + – 1	– + – 2	– + – 3

Note – A received ternary block 000 is decoded as binary 0000.

FIGURE I-1/G.961

MMS43-Code

I.2 *Symbol rate*

The symbol rate is 120 kbaud.

I.2.1 *Clock symbol requirements*

I.2.1.1 *NT1 free running clock accuracy*

The tolerance of the free running NT1 clock is ± 100 ppm.

I.2.1.2 *LT clock tolerance*

The tolerance of the clock signal provided at the LT is ± 1 ppm.

I.3 *Frame structure*

Each frame contains a frame word, 2B + D data and the CL-channel. Multiframe are not used.

I.3.1 *Frame length*

The length of each frame is 120 ternary symbols corresponding to 1 ms. Each frame has 108 symbols (corresponding to 144 bits) carrying 2B + D data.

I.3.2 *Symbol allocation LT to NT1*

In the direction LT to NT1 the 120 symbols of each frame are used as follows:

- Symbols 1 to 84: 2B + D;
- Symbol 85: CL-channel;
- Symbols 110 to 120: frame word.

I.3.3 *Symbol allocation NT1 to LT*

In the direction NT1 to LT, the frame structure is identical to that of the direction LT to NT1.

The frame transmitted by the NT1 is synchronized to that received from the LT.

I.4 *Frame word*

I.4.1 *Frame word in direction LT to NT1*

The frame word in the direction LT to NT1 is:

+ + + ---+---+-

I.4.2 *Frame word in direction NT1 to LT*

The frame word in the direction NT1 to LT is:

-+---+----+++

I.5 *Frame alignment procedure*

The transmission system is considered to be synchronous if the frame word has been identified in the same position for 4 immediately succeeding frames. Loss of synchronization is assumed, if the detected frame position does not coincide with the expected position during 60 . . . 200 successive frames.

I.6 *Multiframe*

Not used.

I.7 *Frame offset at NT1*

On the line at the NT1 the frame word transmitted by the NT1 occurs 60 ± 1 symbols (0.5 ms) later than that received at the NT1 input, measured between the first symbols of each frame word.

I.8 *CL-channel*

I.8.1 *Bit rate*

The bit rate for the CL-channel (maintenance-channel) is 1 kbit/s.

I.8.2 *Structure*

No specific structure is defined for transparent messages.

I.8.3 *Protocols and procedures*

Transparent messages in the CL-channel use “0” and “–” polarity of the CL-symbol of the line signal. “0” and “+” polarity are used to request a loopback 2B + D in the NT1 or an intermediate repeater. Transparent use of the CL-channel may override these loopback commands.

I.9 *Scrambling*

In order to minimize correlation between incoming and transmitted symbols scrambling is used. Scrambling is applied only to the 2B + D-channels.

The scrambling polynomial is different in both NT1 to LT and LT to NT1 directions.

- In direction LT to NT1: $1 \oplus x^{-5} \oplus x^{-23}$
- In direction NT1 to LT: $1 \oplus x^{-5} \oplus x^{-23}$.

where \oplus is the modulo two sum and x^{-k} is the scrambled data delayed by k symbol intervals.

I.10 *Activation/deactivation*

Activation/deactivation is provided to enable the use of a power down state especially for applications, where the NT1 is powered from the LT via the local line. Activation from the power state may be initiated from both ends using a 7.5 kHz burst signal. Collisions are handled through appropriate duration and repetition rate of these bursts.

The procedures on the line system support the procedures at reference point T for call control in accordance with Recommendation I.430 and the operation of loopbacks 1 (in the LT), 1A (in the regenerator) and 2 (in the NT1) in accordance with Recommendation I.603. The loopbacks are transparent.

Timer 1 and timer 2, as defined in Recommendation I.430, are located as follows:

- Timer 1 in the ET layer 1 or the ET,
- Timer 2 in the NT1.

The activation of the line system for maintenance purposes e.g. error performance monitoring, is possible, even if no TE is connected to the interface at T reference point.

Transmission of INFO 2 on the interface of T reference point is initiated when the line system is synchronized in the direction LT to NT1.

I.10.1 *Signals used for activation*

To provide means to control/indicate progress during activation/deactivation across the local line the following signal elements are used:

SIG 0	NT1 to LT and LT to NT1 No signal.
SIG 1W	NT1 to LT Awake signal (7.5 kHz tone); signals the layer 1 entity in the local exchange that it has to enter the power-up state and provide for the activation of the line system and the interface at T reference point. This signal is also used as awake acknowledge on the receipt of SIG 2W.
SIG 2W	LT to NT1 Awake signal (7.5 kHz tone); signals the NT1 that it has to enter the power-up state and prepare for synchronization on an incoming signal from the LT. This signal is also used as awake acknowledge on the receipt of SIG 1W.
SIG 1	NT1 to LT Signal which contains framing information and allows the synchronization of the receiver in the LT. It informs the LT that the NT1 has synchronized on SIG 2.
SIG 2	LT to NT1 Signal which contains framing information and allows the synchronization of the receiver in the NT1.

SIG 1A	NT1 to LT Signal similar to SIG 1 but without framing information.
SIG 3	NT1 to LT Signal which contains framing information and allows the synchronization of the receiver in the LT. It indicates to the ET that the interface at T reference point is synchronized in both directions of transmission (except in the case of loopback 2 and 1A).
SIG 4H	LT to NT1 Signal which requires the NT1 to establish full layer 1 information transfer capability in both directions of transmission.
SIG 4	LT to NT1 Signal which contains framing information and operational data on B and D channels.
SIG 5	NT1 to LT Signal which contains framing information and operational data on B and D channels.
SIG 2-L2	LT to NT1 Signal similar to SIG 2, but includes a loopback 2 request.
SIG 4H-L2	LT to NT1 Signal which requires the NT1 to operate loopback 2 and to establish layer 1 information transfer capability in the direction LT to TE (transparent loopback 2).
SIG 4-L2	Signal similar to SIG 4, but includes a loopback 2 request.

All SIGs, except SIG 1W and SIG 2W, are continuous signals. The awake signals SIG 1W and SIG 2W are sent for a specified period of time only, but may be repeated if no acknowledgement is received. The repetition times are specified in a way to assure a proper interworking with the normal activation procedure.

The loopback requests are transmitted making use of the CL channel. All other SIGs do not require the CL channel.

The CL channel is provided with all SIGs except SIG 0, SIG 1W, SIG 2W and SIG 1A.

I.10.2 *Definition of internal timers*

In the state transition tables and arrow diagrams the following internal timers are used:

Tn1 =	13 ms:	timer to supervise repetition of the awake signal SIG 2W from the LT
T11 =	7 ms:	timer to supervise repetition of the awake signal SIG 1W from the NT1
T12 =	1 ms:	timer which defines the duration of SIG 4H and SIG 4H-L2
T13 =	1 ms:	timer which assures that, under non-failure conditions, the PH-AI is passed first in the TE and then in the LT/ET. This protects the first layer 2 frame (layer 3 – SETUP message) from the network side.
T14 =	12 ms:	timer used to start transmission of SIG 2 when loopback 1 is requested.
T15 =	0.1 . . . 1 s:	timer to supervise the deactivation procedure (within ET).

I.10.3 *Description of the activation procedure*

In Figure I-2/G.961 the activation/deactivation procedures are described for the non-failure situation.

Timer T1 (located in ET layer 1) and Timer T2 (located in NT1) are as specified in Recommendation I.430; the Functional Elements (FE) are defined in Recommendation G.960, § 5.4.1.3, and the primitives in Recommendation G.960, § 5.4.2.2 and § 5.4.2.3.

I.10.4 *NT1 state transition table*

The NT1 state transition table is described in Table I-1/G.961. INFOs on the interface at T reference point are related to SIGs on the line system and vice versa.

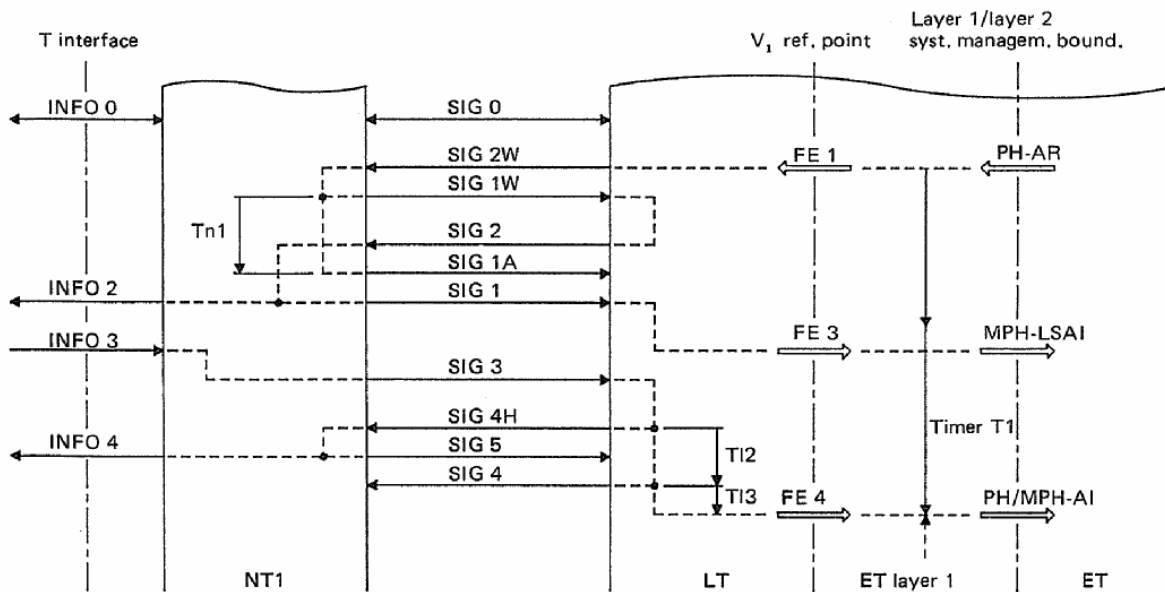

a) Activation from network side

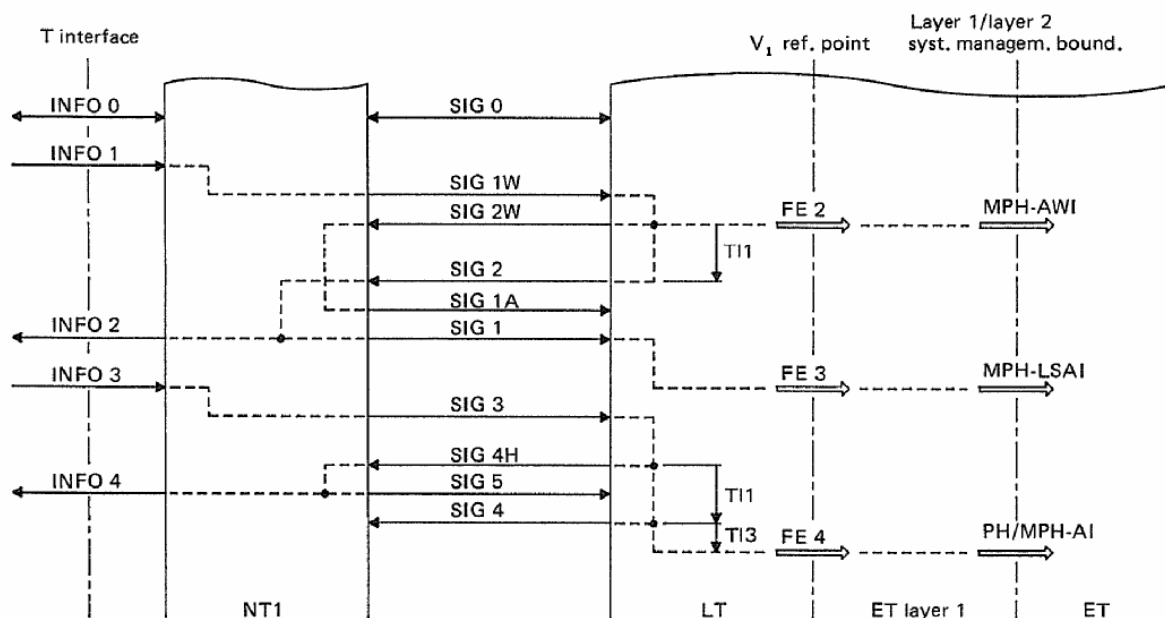

b) Activation from user side

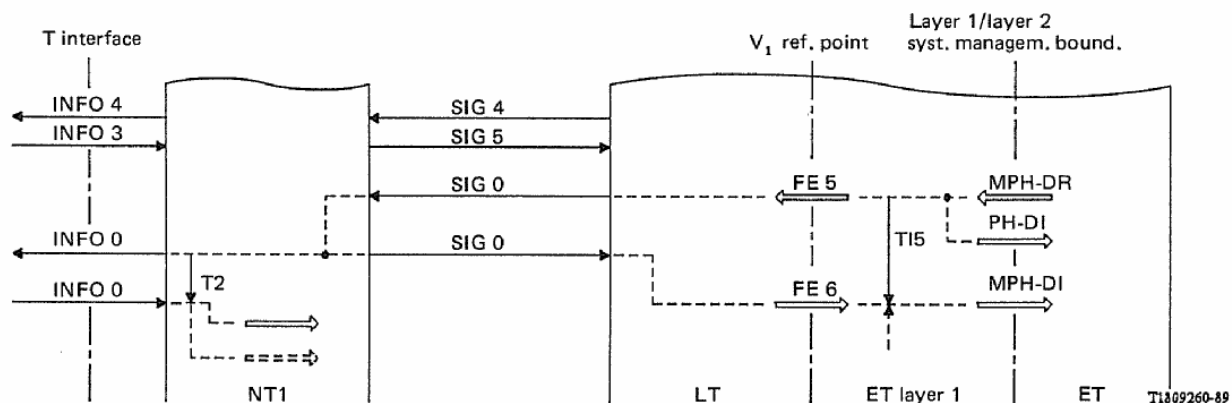

c) Deactivation

FIGURE I-2/G.961

Activation/deactivation procedures: arrow diagrams
(non-failure situations)

TABLE I-1/G.961

NT1 state transition table

State	NT 1.1	NT 1.2	NT 1.3	NT 1.4	NT 1.5	NT 1.6	NT 1.7	NT 1.8	NT 1.9	NT 1.10	NT 2.1	NT 2.2
Transmit signal Receive signal	INFO 0	INFO 0	INFO 0	INFO 0	INFO 2	INFO 2	INFO 4	INFO 0	INFO 2	INFO X (Note 2)	INFO 2	INFO 4 (Note 4)
	SIG 0	SIG 1W	SIG 1W	SIG 1A	SIG 1	SIG 3	SIG 5	SIG 0	SIG 5	SIG 0 (Note 3)	SIG 3	SIG 5 (Note 5)
INFO 0	–	–	–	–	–	–	NT 1.9	NT 1.1	–	–	–	–
INFO 1	NT 1.2	–	–	–	–	–	/	–	–	/	–	/
INFO 3	/	/	/	/	NT 1.6	–	–	–	TR 1.7	/	–	–
SIG 0	–	–	–	ST.T2; NT 1.8	ST.T2; NT 1.8	ST.T2; NT 1.8	ST.T2; NT 1.8	–	ST.T2; NT 1.8	ST.T2; NT 1.8	ST.T2; NT 1.8	ST.T2; NT 1.8
SIG 2W	ST. TN1; NT 1.3	NT 1.4	/	/	/	/	/	/	/	/	/	/
SIG 2	/	–	–	NT 1.5	–	–	/	/	/	/	NT 1.6 or –	/
SIG 4H	/	/	/	/	/	NT 1.7	–	/	/	/	NT 1.7	/
SIG 4	/	/	/	/	/	/	–	/	–	–	/	NT 1.7
Exp. of T2 (Note 1)	–	–	–	–	–	–	–	NT 1.1	–	–	–	–
Lost framing T interface	/	/	/	/	/	–	NT 1.9	–	–	–	/	/
Lost framing line system	/	/	/	/	NT 1.10	NT 1.10	NT 1.10	/	NT 1.10	–	NT 1.10	NT 1.10
Exp. of internal timer Tn1	/	/	NT 1.4	/	/	/	/	/	/	/	/	/

TABLE I-1/G.961 (cont.)

State	NT 1.1	NT 1.2	NT 1.3	NT 1.4	NT 1.5	NT 1.6	NT 1.7	NT 1.8	NT 1.9	NT 1.10	NT 2.1	NT 2.2
Transmit signal	INFO 0	INFO 0	INFO 0	INFO 0	INFO 2	INFO 2	INFO 4	INFO 0	INFO 2	INFO X (Note 2)	INFO 2	INFO 4 (Note 4)
	SIG 0	SIG 1W	SIG 1W	SIG 1A	SIG 1	SIG 3	SIG 5	SIG 0	SIG 5	SIG 0 (Note 3)	SIG 3	SIG 5 (Note 5)
Receive signal												
SIG 2-L2	/	–	–	NT 2.1	NT 2.1 or –	NT 2.1 or –	/	/	/	/	–	/
SIG 4H-L2	/	/	/	/	/	NT 2.2	–	/	/	/	NT 2.2	–
SIG 4-L2	/	/	/	/	/	/	NT 2.2	/	NT 2.2	NT 2.2	/	–

– No state change.

/ Impossible by the definition of peer-to-peer physical layer procedures or system internal reasons.

ST.Tx; NTy Start Timer x; enter state NT y.

Note 1 – Timer T2 as defined in Recommendation I.430.

Note 2 – INFO X: signal with no framing information i.e. binary ZERO's.

Note 3 – Any other signal which produces an error indication on the LT side is allowed, especially loss of framing or excessive error rate.

Note 4 – The D-Echo bit is set to binary ZERO.

Note 5 – The B- and D-channels are looped back to the network side.

The following states are used:

- NT 1.1 Deactivated state (low power consumption mode). No signal is transmitted.
- NT 1.2 The NT1 sends the awake signal SIG 1W to the LT, on the receipt of INFO 1 from the user side, and waits for the receipt of the awake acknowledge signal SIG 2W from the LT.
- NT 1.3 On receipt of the awake signal SIG 2W, the NT1 responds with SIG 1W and starts transmission of SIG 1A on expiry of timer Tn1, unless a new awake signal SIG 2W from the LT is received.
- NT 1.4 After completion of the awake procedure, the NT1 waits for SIG 2 to synchronize its receiver.
- NT 1.5 The receiver on the network side is synchronized. The NT1 sends SIG 1 to the LT and INFO 2 to the user side to initiate the activation of the interface of reference point T. It waits for the receipt of INFO 3.
- NT 1.6 The interface at T reference point is synchronized in both directions of transmission. The NT1 sends SIG 3 to the LT and waits for the receipt of SIG 4H.
- NT 1.7 The NT1 is fully active and sends INFO 4 to the user side and SIG 5 to the LT. The B and D channels are operational.
- NT 1.8 Pending deactivation state. The NT1 sends INFO 0 to the user side to deactivate the interface at reference point T and SIG 0 to the LT. It waits for the receipt of INFO 0 or expiry of timer T2 to enter state NT1.1.
- NT 1.9 This state is entered on loss of signal or loss of framing at the T interface. No indication is sent to the LT, in accordance with Note 3 to Table 4/I.430.
- NT 1.10 This state is entered on loss of framing at the line side. An indication is forwarded to the user side (INFO X) and to the network side (SIG 0).

The following states support activation when loopback 2 is requested:

- NT 2.1 The receiver on the network side is synchronized. The NT1 sends SIG 3 to the LT and INFO 2 to the user side (transparent loopback). It waits for the receipt of SIG 4H-L2 from the LT.
- NT 2.2 The NT1 is fully active and sends INFO 4 to the user side (transparent loopback) and SIG 5 to the LT. Loopback 2 is operated and receive data 2B + D are sent to the LT.

I.10.5 *LT state transition table*

The LT state transition table is described in Table I-2/G.961. SIGs on the line system are related to Functional Elements (FEs) on the V₁ reference point.

The following states are used:

- LT 1.1 Deactivated state. No signal is transmitted.
- LT 1.2 On receipt of the awake signal SIG 1W, the LT responds with SIG 2W and starts transmission of SIG 2 on expiry of timer T11, unless a new awake signal SIG 1W from the NT1 is received.
- LT 1.3 The LT sends the awake signal SIG 2W to the NT1, on the receipt of FE 1, and waits for the awake acknowledge signal SIG 1W from the NT1.
- LT 1.4 The LT sends SIG 2 to the NT1 and waits for SIG 1 or SIG 3 to synchronize its receiver. When the LT is synchronized and has detected SIG 1, it issues FE 3.
- LT 1.5 The line transmission system is synchronized in both directions of transmission. The LT waits for the receipt of SIG 3.
- LT 1.6 The line transmission system and the interface at T reference point are synchronized in both directions of transmission. The LT sends SIG 4H until the expiry of timer T12.
- LT 1.7 Fully active state. The LT sends SIG 4 to the NT1 and issues FE 4. The B and D channels are fully operational.
- LT 1.8 Pending deactivation state. The LT sends SIG 0 to the NT1 to deactivate the line system and the interface at T reference point. It waits for the receipt of SIG 0 to enter state LT 1.1 and to issue FE 6.

TABLE I-2/G.961

LT state transition table

State	LT 1.1	LT 1.2	LT 1.3	LT 1.4	LT 1.5	LT 1.6	LT 1.7	LT 1.8	LT 2.1	LT 2.2	LT 2.3	LT 2.4
Transmit signal / Receive signal	SIG 0	SIG 2W	SIG 2W	SIG 2	SIG 2	SIG 4H	SIG 4	SIG 0	SIG 2W	SIG 2	SIG 4H	SIG 4
EF 1	LT 1.3	–	–	–	–	–	–	–	–	–	–	–
EF 5	:	LT 1.8	LT 1.8	LT 1.8	LT 1.8	LT 1.8	LT 1.8	–	LT 1.8	LT 1.8	LT 1.8	LT 1.8
SIG 0	–	–	–	–	FE 7; –	FE 7; –	FE 7; –	FE 6; LT 1.1	–	–	–	–
SIG 1W	ST.T11, FE 2; LT 1.2	:	LT 1.4	/	/	/	/	–	–	/	/	/
SIG 1	/	/	/	FE 3; LT 1.5	–	/	/	–	/	–	–	–
SIG 3	/	/	/	ST.T12; LT 1.6	ST.T12; LT 1.6	–	–	–	/	–	–	–
Exp. of intern. timer T11	–	LT 1.4	–	–	–	–	–	–	–	–	–	–
Exp. of intern. timer T12	–	–	–	–	–	FE 7; LT 1.4	–	–	–	–	FE 4; LT 2.4	–
Lost framing line system	/	/	/	/	FE 7; –	FE 7; –	FE 7; –	–	/	/	/	/

TABLE I-2/G.961

State	LT 1.1	LT 1.2	LT 1.3	LT 1.4	LT 1.5	LT 1.6	LT 1.7	LT 1.8	LT 2.1	LT 2.2	LT 2.3	LT 2.4
Transmit signal												
Receive signal	SIG 0	SIG 2W	SIG 2W	SIG 2	SIG 2	SIG 4H	SIG 4	SIG 0	SIG 2W	SIG 2	SIG 4H	SIG 4
FE 4	ST.T14; LT 2.1	–	LT 2.2 or –	LT 2.2 or –	LT 2.2 or –	–	–	LT 2.1	:	:	:	:
Exp. of item. timer T14	–	–	–	–	–	–	–	–	LT 2.2	–	–	–
Rec. synch. on looped b. sig.	/	/	/	–	–	–	–	–	/	ST.T12; LT 2.3	–	–

– No state change.

/ Impossible by the definition of peer-to-peer physical layer procedures or system internal reasons.

:

a, b; LTx Perform action/issue message a and b; enter state LTx.

ST.Tlx Start Timer Tlx.

The following states support activation when loopback 1 is requested:

- LT 2.1 The LT sends the awake signal SIG 2W to the NT1 (transparent loopback), on the receipt of FE 9, and starts transmission of SIG 2 on expiry of timer TI4.
- LT 2.2 The LT has operated loopback 1 and is synchronizing its receiver on the looped back signal.
- LT 2.3 The LT sends SIG 4H until the expiry of timer TI2.
- LT 2.4 The LT is fully active and sends SIG 4 to the NT1 (transparent loopback). Loopback 1 is operated.

The LT state transition table is not affected by loopback 2 and 1A requests. The corresponding control signals are transferred across channels C_{V1} and CL.

I.10.6 Activation times

For definition of activation times see Recommendation G.960, § 5.5.

- a) Maximum activation time for activation occurring immediately after a deactivation:
 - without regenerator: 210 ms.
 - with regenerator: 420 ms.
- b) Maximum time for activation occurring after the first powering of a line
 - without regenerator: 1.5 s.
 - with regenerator: 3 s.

I.11 Jitter

Jitter tolerances shall assure that the maximum network limit of jitter (see Recommendation G.823) is not exceeded.

Furthermore, the limits of Recommendation I.430 must be supported by the jitter limits of the transmission system on local lines.

The jitter limits given below must be satisfied regardless of the length of the local line and the inclusion of repeaters, provided that they are covered by the transmission media characteristic (see § 3). The limits must be met regardless of the transmitted signal. A suitable test sequence is for further study (see Recommendation G.823, § 4).

I.11.1 Limits of maximum tolerable input jitter

The amplitude of the jitter at the NT1 input shall be limited by the template given in Figure I-3/G.961.

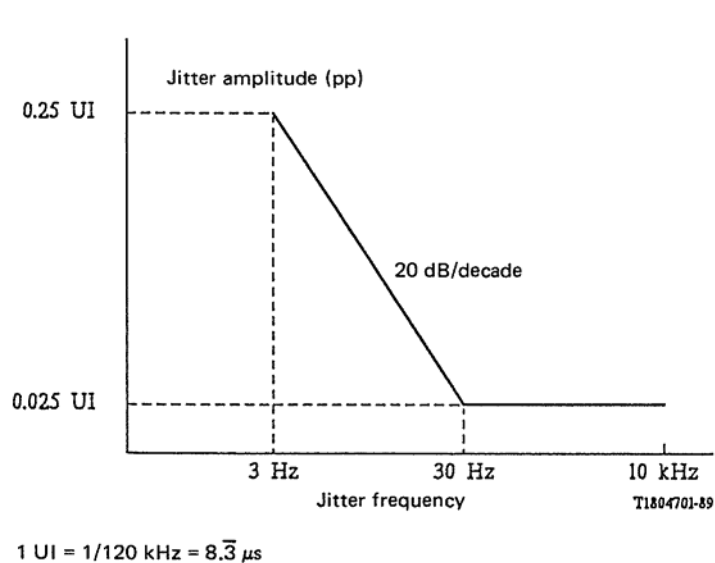

FIGURE I-3/G.961

Minimum tolerable sinusoidal input jitter

I.11.2 *Output jitter of NT1 in absence of input jitter*

When measured with a highpass filter with a 30 Hz cut-off frequency, the jitter at the output of the NT1 shall not exceed 0.02 U_{Ipp}. Without a filter, the jitter shall not exceed 0.1 U_{Ipp}.

I.11.3 *Timing extraction jitter*

The jitter at the output of the NT1 shall closely follow the input jitter. Therefore, the jitter transfer function of the NT1 shall be less than ± 1 dB in the frequency range 3 Hz to 30 Hz.

I.11.4 *Test conditions for jitter measurements*

For further study.

I.12 *Transmitter output characteristics*

I.12.1 *Pulse amplitude*

The amplitude of a transmitted single pulse shall be 2V ± 0.2V with a load impedance of 150 ohm.

I.12.2 *Pulse shape*

The shape of a transmitted single pulse shall fit the mask given in Figure I-4/G.961.

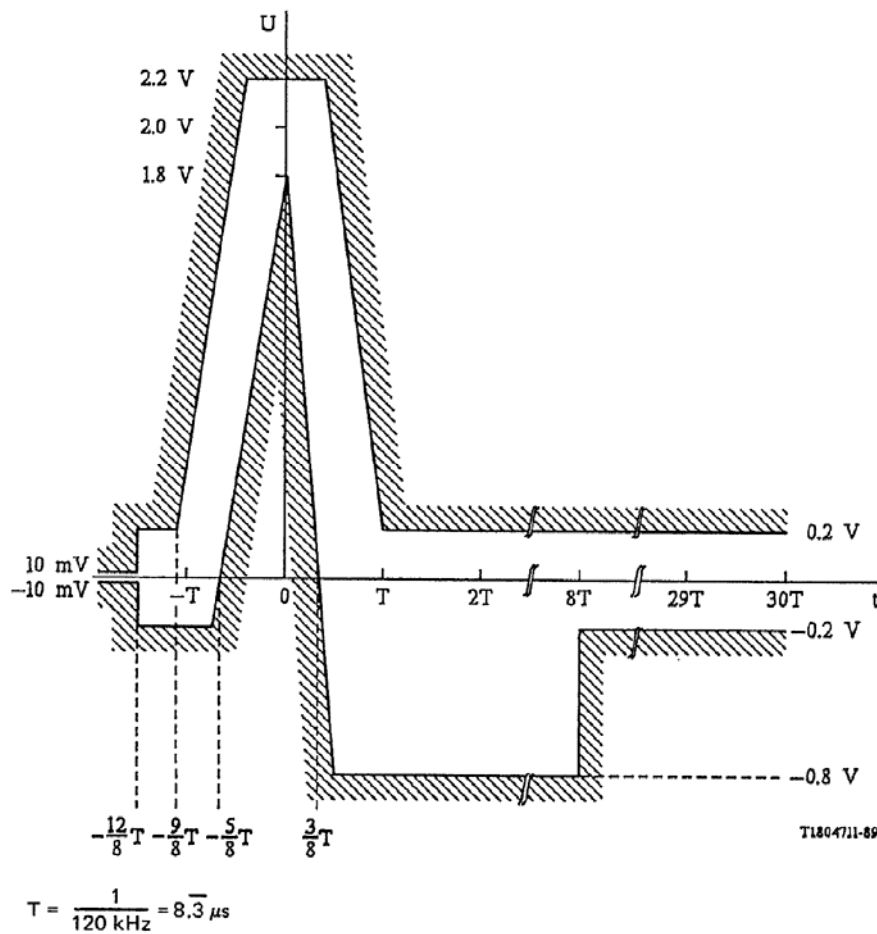

FIGURE I-4/G.961

Pulse mask for transmitted single pulse

I.12.3 *Signal power*

Not specified.

I.12.4 *Power spectrum*

The upper bound of the power spectral density shall be limited according to Figure I-5/G.961.

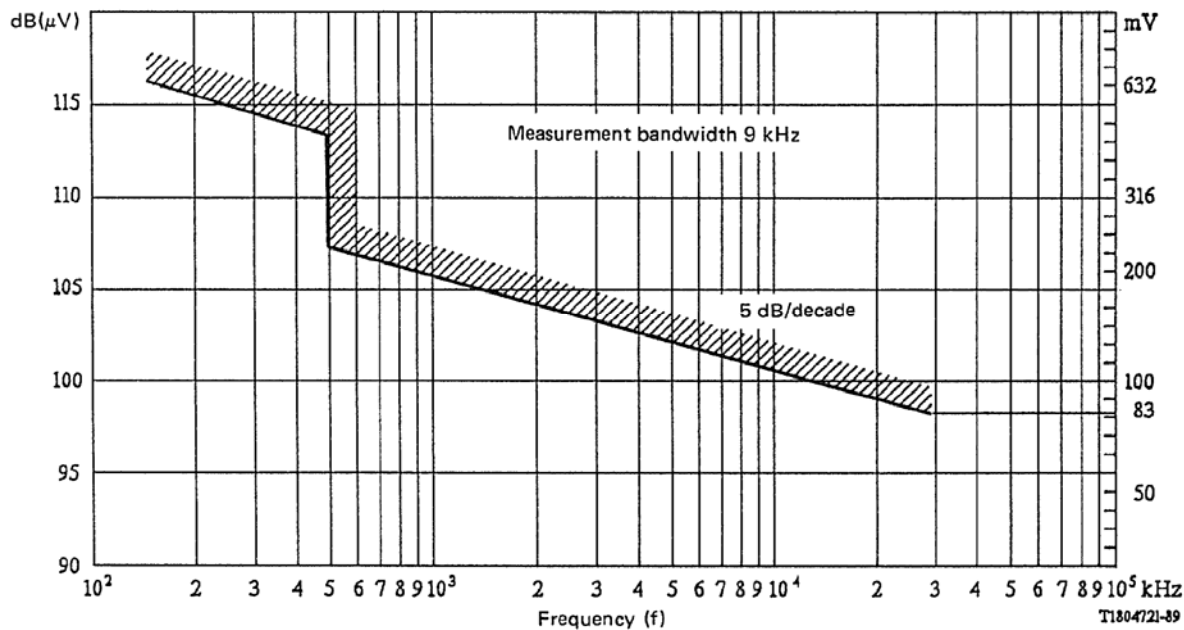

FIGURE I-5/G.961

Limits of transmit power spectrum

I.12.5 *Transmitter signal nonlinearity*

Not specified.

I.13 *Transmitter/receiver termination*

I.13.1 *Impedance*

The nominal output/input impedance of the NT1 and LT shall be 150 ohm.

I.13.2 *Return loss*

The return loss against 150 ohm ± 1% measured for NT1 or LT shall exceed the limits given in Figure I-6/G.961.

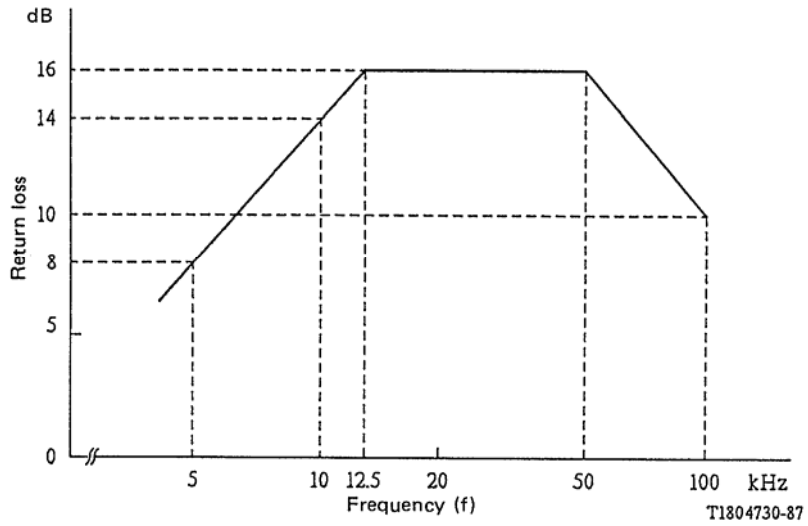

FIGURE I-6/G.961
NT1 and LT return loss

I.13.3 *Longitudinal conversion loss*

The longitudinal conversion loss at the line interface for LT and NT1 shall exceed the limits given in Figure I-7/G.961.

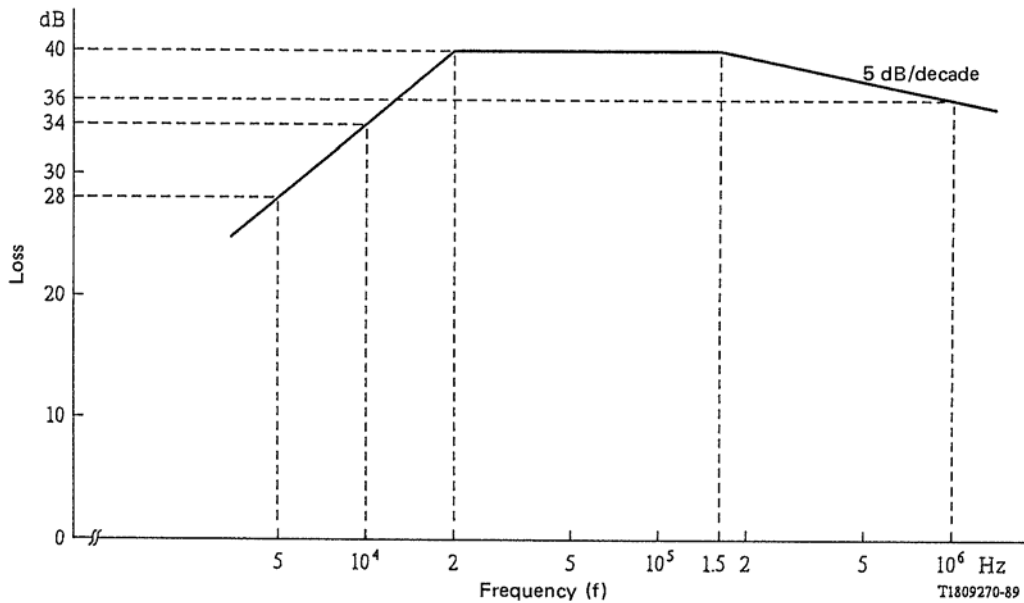

FIGURE I-7/G.961
Longitudinal conversion loss

APPENDIX II

(to Recommendation G.961)

Electrical characteristics of a 2B1Q transmission system

II.1 *Line code*

The line code shall be 2B1Q (2 binary, 1 quaternary). This is a 4-level code and is used without redundancy.

The bit stream entering the NT1 from the interface at reference point T (or entering the LT from the ET) shall be grouped into pairs of bits for conversion to quaternary symbols that are called quats. Figure II-1/G.961 shows the relationship of the bits in the B and D channels to quats. The B- and D-channel bits are scrambled before coding. M_1 through M_6 bits of the CL channel are also paired, coded and scrambled in the same way.

Data	Time →									
	B ₁				B ₂				D	
Bit pairs	$b_{11}b_{12}$	$b_{13}b_{14}$	$b_{15}b_{16}$	$b_{17}b_{18}$	$b_{21}b_{22}$	$b_{23}b_{24}$	$b_{25}b_{26}$	$b_{27}b_{28}$	d_1d_2	
Quat # (relative)	q_1	q_2	q_3	q_4	q_5	q_6	q_7	q_8	q_9	
# Bits	8				8				2	
# Quats	4				4				1	

- b_{11} First bit of B₁ octet received at reference point T
- b_{18} Last bit of B₁ octet received at reference point T
- b_{21} First bit of B₂ octet received at reference point T
- b_{28} Last bit of B₂ octet received at reference point T
- d_1d_2 Consecutive D-channel bits
(d_1 is first bit of pair as received at reference point T)
- q_i i th quat relative to start of given 18-bit 2B + D data field

Note – There are 12 2B + D 18-bit fields per 1.5 ms basic frame.

FIGURE II-1/G.961

2B1Q encoding of 2B + D bit fields

Each successive pair of scrambled bits in the binary data stream is converted to a quaternary symbol to be output from the transmitters, as specified below:

First bit (sign)	Second bit (magnitude)	Quaternary symbol (quat)
1	0	+ 3
1	1	+ 1
0	1	- 1
0	0	- 3

At the receiver, each quaternary symbol is converted to a pair of bits by reversing the table above, descrambled, and formed into a bit stream representing B and D channels and a CL channel containing M bits for maintenance and other purposes. The bits in the B and D channels are properly placed by reversing the relationship in Figure II-1/G.961.

II.2 *Line baud rate*

The line symbol rate is 80 kbauds.

II.2.1 *Clock tolerance*

II.2.1.1 *NT1 clock tolerance*

The tolerance of the free running NT1 clock is ± 100 ppm.

II.2.1.2 *LT clock tolerance*

The tolerance of the clock provided at the LT is ± 5 ppm.

II.3 *Frame structure*

A frame shall be 120 quaternary symbols transmitted within a nominally 1.5 ms. interval. Each frame contains a frame word, 2B + D data and CL channel bits shown in Figure II-2/G.961.

	← 1.5 ms →		
Frame	FW/IFW	12 × (2B + D)	CL
Function	Frame word	2B + D	Overhead
# Quats	9	108	3
Quat positions	1-9	10-117	118-120
<hr/>			
# Bits	18	216	6
Bit position	1-18	19-234	235-240
<hr/>			

- quat Quaternary symbol = 1 baud
- 3, -1, +1, +3 Symbol names
- 2B + D Customer data channel B₁, B₂ et D
- FW Frame Word (9-Symbol Code) = +3 +3 -3 -3 -3 +3 -3 +3 +3
- IFW Inverted (or complementary) Frame Word = -3 -3 +3 +3 +3 -3 +3 -3 -3
- CL M-Channel Bits M₁-M₆

Note – Frames in the NT1-to-Network direction are offset from frames in the Network-to-NT1 direction by 60 ± 2 quats.

FIGURE II-2/G.961

Frame structure of 2B1Q transmission system

II.3.1 *Frame length*

The number of 2B + D slots in a frame is 12. Each slot contains 18 bits.

II.3.2 *Bit allocation in direction LT-NT1*

The bit allocation of the frames are shown in Figures II-1/G.961 and II-2/G.961.

II.3.3 *Bit allocation in direction NT1-LT*

See § II.3.2.

II.4 *Frame word*

The frame word is used to allocate bit positions to the B, D, and CL channels. It may be also used for baud synchronization.

II.4.1 *Frame word in direction LT-NT1*

The code for the frame word in all frames except the first in a multiframe shall be:

$$FW = +3 +3 -3 -3 -3 +3 -3 +3 +3$$

The code for the frame word of the first frame of a multiframe shall be an inverted frame word (IFW):

$$IFW = -3 -3 +3 +3 +3 -3 +3 -3 -3$$

II.4.2 *Frame word in direction NT1-LT*

See § II.4.1.

II.5 *Frame alignment procedure*

Not specified.

II.6 *Multiframe*

To enable the allocation of the CL channel bits over more than one frame, a multiframe is used. The start of the multiframe is determined by the inverted frame word (IFW). The number of frames in a multiframe is 8.

II.6.1 *Multiframe word in direction NT1-LT*

See § II.4.1.

II.6.2 *Multiframe word in direction LT-NT1*

See § II.4.1.

II.7 *Frame offset between LT-NT1 and NT1-LT frames*

The NT1 shall synchronize transmitted frames with received frames (LT-NT1 direction). Transmitted frames shall be offset with respect to received frames by 60 ± 2 quaternary symbols (i.e., about 0.75 ms).

II.8 *CL channel*

II.8.1 *Bit rate*

The bit rate for the CL channel is 4 kbit/s.

II.8.2 *Structure*

Forty eight bits of a multiframe are used for the CL channel and are referred to as M bits.

Twenty four bits per multiframe (2 kbit/s) are allocated to an embedded operations channel (EOC) which supports operations communications needs between the network and the NT1.

Twelve bits per multiframe (1 kbit/s) are allocated to a cyclic redundancy check (CRC) function.

Twelve bits per multiframe (1 kbit/s) are allocated to other functions and spare bits as shown in Figure II-3/G.961.

		Framing	2B + D	CL (overhead) bits $M_1 - M_6$					
Quat positions		1-9	10-117	118s	118m	119s	119m	120s	120m
Bit positions		1-18	19-234	235	236	237	238	239	240
Multi-frame #	Basic frame #	Frame word	2B + D	M_1	M_2	M_3	M_4	M_5	M_6
LT to NT1									
A	1	IFW	2B + D	EOC_{a1}	EOC_{a2}	EOC_{a3}	ACT	1	1
	2	FW	2B + D	EOC_{dm}	EOC_{i1}	EOC_{i2}	DEA	1	FEBE
	3	FW	2B + D	EOC_{i3}	EOC_{i4}	EOC_{i5}	1	CRC ₁	CRC ₂
	4	FW	2B + D	EOC_{i6}	EOC_{i7}	EOC_{i8}	1	CRC ₃	CRC ₄
	5	FW	2B + D	EOC_{a1}	EOC_{a2}	EOC_{a3}	1	CRC ₅	CRC ₆
	6	FW	2B + D	EOC_{dm}	EOC_{i1}	EOC_{i2}	1	CRC ₇	CRC ₈
	7	FW	2B + D	EOC_{i3}	EOC_{i4}	EOC_{i5}	1	CRC ₉	CRC ₁₀
	8	FW	2B + D	EOC_{i6}	EOC_{i7}	EOC_{i8}	1	CRC ₁₁	CRC ₁₂
B, C, ...									
NT1 to LT									
1	1	IFW	2B + D	EOC_{a1}	EOC_{a2}	EOC_{a3}	ACT	1	1
	2	FW	2B + D	EOC_{dm}	EOC_{i1}	EOC_{i2}	PS ₁	1	FEBE
	3	FW	2B + D	EOC_{i3}	EOC_{i4}	EOC_{i5}	PS ₂	CRC ₁	CRC ₂
	4	FW	2B + D	EOC_{i6}	EOC_{i7}	EOC_{i8}	NTM	CRC ₃	CRC ₄
	5	FW	2B + D	EOC_{a1}	EOC_{a2}	EOC_{a3}	CSO	CRC ₅	CRC ₆
	6	FW	2B + D	EOC_{dm}	EOC_{i1}	EOC_{i2}	1	CRC ₇	CRC ₈
	7	FW	2B + D	EOC_{i3}	EOC_{i4}	EOC_{i5}	1	CRC ₉	CRC ₁₀
	8	FW	2B + D	EOC_{i6}	EOC_{i7}	EOC_{i8}	1	CRC ₁₁	CRC ₁₂
2, 3, ...									

1	Reserve = bit for future standard; set = ONE
EOC	Embedded operations channel
a	Address bit
dm	Data/message indicator
i	Information (data/message)
FW	Frame word
IFW	Inverted frame word
s	sign bit (first) in quat
m	Magnitude bit (second) in quat
ACT	Activation bit (set to ONE during activation)
PS ₁ , PS ₂	Power status bits (set to ZERO to indicate power problems)
NTM	NT1 in Test Mode bit (set to ZERO to indicate test mode)
CSO	Cold-start-only bit (set to ONE to indicate cold-start-only)
CRC	Cyclic redundancy check: covers 2B + D and M4
1	Most significant bit
2	Next most significant bit
etc.	
DEA	Deactivation bit (set to ZERO to announce deactivation)
FEBE	Far end block error bit set to ZERO for errored multiframe)

Note 1 – NT1-to-Network multiframe delay offset from Network-to-NT1 multiframe by 60 ± 2 quats (about 0.75 ms). All bits other than the frame word are scrambled.

Note 2 – 8×1.5 ms basic frames \rightarrow 12 ms multiframe.

FIGURE II-3/G.961

2B1Q multiframe technique and overhead bit assignments

II.8.3 Protocol and procedures

The CL-channel functions (M bits) specified below are based on the bit allocation for the multiframe defined in Figure II-3/G.961.

II.8.3.1 Error monitoring function

II.8.3.1.1 Cyclic redundancy check (CRC)

The CRC bits are the M₅ and M₆ bits in frames 3 through 8 of the multiframe. The CRC is an error detection code that shall be generated from the appropriate bits in the multiframe and inserted into the bit stream by the transmitter. At the receiver a CRC calculated from the same bits shall be compared with the CRC value received in the bit stream. If the two CRCs differ, there has been at least one error in the covered bits in the multiframe.

II.8.3.1.2 CRC algorithms

The Cyclic Redundancy Check (CRC) code shall be computed using the polynomial:

$$P(x) = x^{12} \oplus x^{11} \oplus x^3 \oplus x^2 \oplus x \oplus 1$$

where

\oplus = modulo 2 summation.

One method of generating the CRC code for a given multiframe is illustrated in Figure II-4/G.961. At the beginning of a multiframe all register cells are cleared. The multiframe bits to be covered by the CRC are then clocked into the generator from the left. During bits which are not covered by the CRC (FW, IFW, M₁, M₂, M₃, M₅, M₆) the state of the CRC generator is frozen and no change in state of any of the stages takes place. After the last multiframe bit to be covered by the CRC is clocked into register cell 1, the 12 register cells contain the CRC code of the next multiframe. Between this point and the beginning of the next multiframe, the register cell contents are stored for transmission in the CRC field of the next multiframe. Notice that bit CRC1 resides in register cell 12, CRC2 in register cell 11, etc.

Note – The binary ONES and ZEROS from the interface at the T reference point, and corresponding bits from the network (across the V₁ reference point), must be treated as binary ONES and ZEROS, respectively, for the computation of the CRC.

II.8.3.1.3 *Bits covered by the CRC*

The CRC bits shall be calculated from the bits in the D channel, both B channels, and the M₄ bits.

II.8.3.2 *Other M-bit functions*

A number of transceiver operations and maintenance functions are handled by M₄, M₅, and M₆ bits in the multiframe. These bits are defined in the following paragraphs.

II.8.3.2.1 *Far end block error (FEBE) bit*

A single bit in each multiframe is allocated to carrying the Far End Block Error (FEBE) bit. The FEBE bit shall be set to ONE if there are no CRC errors in the multiframe and ZERO if the multiframe contains a CRC error. The FEBE bit shall be placed in the next available outgoing multiframe and transmitted back to the originator. The FEBE bits may be monitored to determine the performance of the far end receiver.

II.8.3.2.2 *The act bit*

The act bit is the M₄ bit in the first frame of multiframes transmitted by either transceiver. The act bit is used as a part of the start-up sequence to communicate readiness for layer 2 communication progress (see § II.10.5).

II.8.3.2.3 *The DEA Bit*

The DEA bit is the M₄ bit in the second frame of multiframes transmitted from the LT (see § II.3 and Figure II-3/G.961). The DEA bit is used by the LT to communicate to the NT1 its intention to deactivate (see § II.10.1.5.2). To permit reliable detection of the DEA bit when indicating the intention to deactivate, its corresponding status (binary ZERO) shall be transmitted in three successive multiframes before terminating transmission of signal.

II.8.3.2.4 *NT1 power status bits*

Two bits of each multiframe (Figure II-3/G.961) shall be used to indicate NT1 power status. Table II-1/G.961 shows the power status bit assignments and the corresponding messages and definitions.

The NT1 must have sufficient energy storage to transmit the dying gasp indication for a minimum of 3 multiframes.

II.8.3.2.5 *NT1 test mode indicator bit*

One bit, NTM, of each multiframe (Figure II-3/G.961) from the NT1 to the LT shall be used to indicate that the NT1 is in a customer initiated test mode. The NT1 is considered to be in a test mode when the D channel or either one of the B channels are involved in a customer locally-initiated maintenance action. While in test mode, the NT1 may be unavailable for service or the NT1 may be unable to perform actions requested by EOC messages. The bit shall be a binary ONE to indicate normal operation and a binary ZERO indicate test mode.

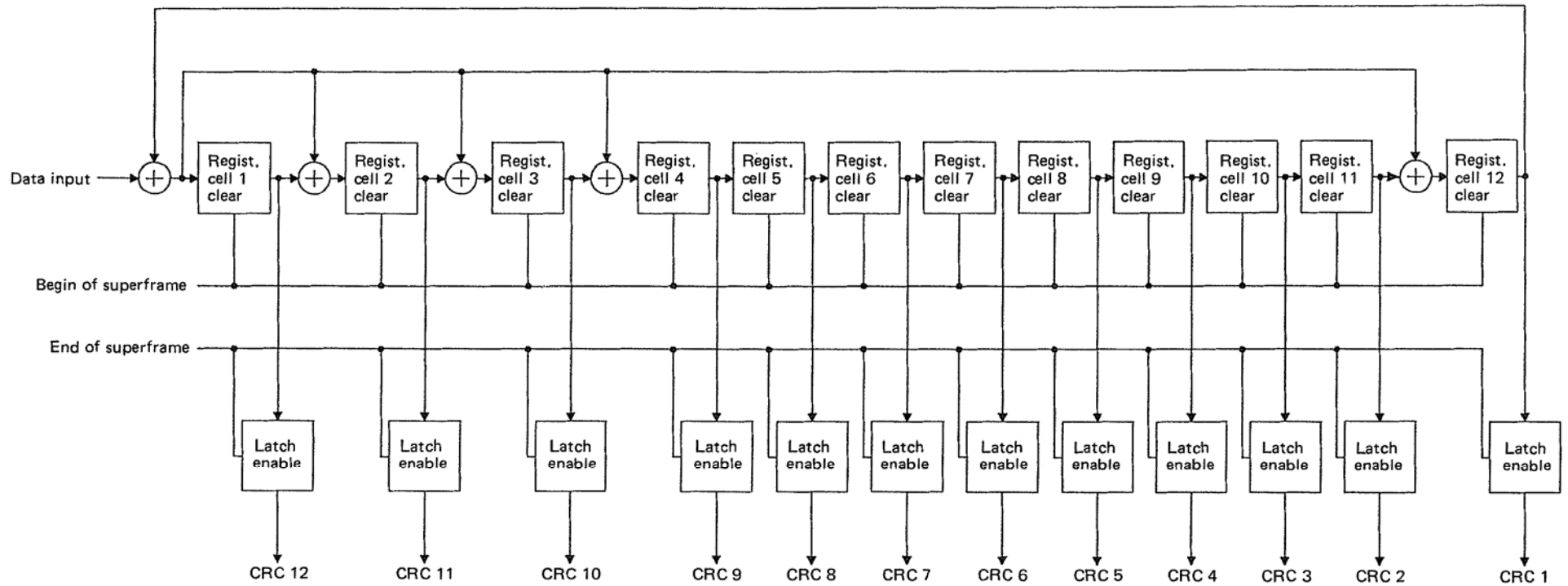

T1809280-89

FIGURE II-4/G.961

CRC-12 generator

TABLE II-1/G.961

Power status bit assignments and messages

NT1 status	$ps_1 ps_2$ binary values	Definition
All power normal	11	Primary and secondary power supplies are both normal
Secondary power out	10	Primary power is normal, but the secondary power is marginal, unavailable, or not provided
Primary power out	01	Primary power is marginal or unavailable, secondary power is normal
Dying gasp	00	Both primary and secondary power are marginal or unavailable. The NT1 may shortly cease normal operation

II.8.3.2.6 *Cold-start-only bit*

The CSO bit is the M_4 bit in the fifth frame of the multiframe transmitted by an NT1. It shall be used to indicate the start-up capabilities of the NT1 transceiver. If the NT1 has a cold-start-only transceiver, as defined in part 4) of § II.10, this bit is set to ONE. Otherwise, this bit shall be set to ZERO in SN3.

II.8.3.2.7 *Reserved bits*

All bits in M_4 , M_5 , and M_6 not otherwise assigned are reserved for future standardization. Reserved bits shall be set to ONE before scrambling.

II.8.3.3 *Embedded operations channel (EOC) functions*

Twenty-four bits per multiframe (2 kbps) are allocated to an embedded operations channel (EOC) which supports operations communications needs between the network and the NT1.

II.8.3.3.1 *EOC frame*

The EOC frame shall be composed of 12 bits synchronized to the multiframe:

Bits	3	1	8
Functions provided	Address field	Data msg indicator	Info field

The three-bit Address Field may be used to address up to 7 locations. Only the specification of addresses of messages for the NT1 are within the scope of this Recommendation. The additional addresses are for intermediate network elements where the system is used to extend access involving carrier systems.

The Data/Message Indicator bit shall be set to ONE to indicate that the Information Field contains an operations message; it shall be set to ZERO to indicate that the Information Field contains numerical data. Up to 256 messages may be encoded in the information field.

Exactly two EOC frames shall be transmitted per multiframe consisting of all M_1 , M_2 , and M_3 bits (see Figure II-3/G.961).

I.8.3.3.2 *Mode of operation*

The EOC protocol operates in a repetitive command/response mode. Three identical properly-addressed consecutive messages shall be received before an action is initiated. Only one message, under the control of the network shall be outstanding (not yet acknowledged) on a complete basic access EOC at any one time.

The network shall continuously send an appropriately addressed message. In order to cause the desired action in the addressed element, the network shall continue to send the message until it receives three identical consecutive EOC frames from the addressed device that agree with the transmitted EOC frame. When the network is trying to activate an EOC function, autonomous messages from the NT1 will interfere with confirmation of receipt of a valid EOC message. The sending by the NT1 and receipt by the network of three identical consecutive properly addressed Unable to Comply messages constitutes notification to the network that the NT1 does not support the requested function, at which time the network may abandon its attempt.

The addressed element shall initiate action when, and only when, three identical, consecutive, and properly addressed EOC frames, that contain a message recognized by the addressed element, have been received. The NT1 shall respond to all received messages. The response should be an echo of the received EOC frame towards the network with two exceptions described below. Any reply or echoed EOC frame shall be in the next available returning EOC frame, which allows a processing delay of approximately 0.75 ms.

If the NT1 does not recognize the message in a properly addressed EOC frame, rather than echo, on the third and all subsequent receipts of that same correctly addressed EOC frame it shall return the Unable to Comply message in the next available EOC frame.

If the NT1 receives EOC frames with addresses other than its own address (000), or the broadcast address (111), it shall, in the next available EOC frame, return an EOC frame toward the network containing the hold state message and its own address (the NT1, address, 000).

The protocol specification has made no provision for autonomous messages from the NT1.

All actions to be initiated at the NT1 shall be latching, permitting multiple eoc-initiated actions to be in effect simultaneously. A separate message shall be transmitted by the network to unlatch.

II.8.3.3.3 *Addressing*

An NT1 shall recognize either of two addresses, an NT1 and a broadcast address. These addresses are as follows:

	Node	Address
	NT1	000
Broadcast	(all nodes)	111

An NT1 shall use the address 000 in sending the Unable to Comply message.

II.8.3.3.4 *Definition of required EOC functions*

- 1) *Operate 2B + D loopback:* This function directs the NT1 to loopback the user-data (2B + D) bit stream toward the network. This loopback is complete and may be transparent or non-transparent but in either case will continue to provide sufficient signal to allow the TE to maintain synchronization to the NT1.
- 2) *Operate B1-Channel (or B2-Channel) loopback:* This function directs the NT1 to loopback an individual B channel toward the network. The individual B-channel loopback can provide per-channel maintenance capabilities without totally disrupting service to the customer. This loopback is transparent.
- 3) *Return to normal:* The purpose of this message is to release all outstanding EOC controlled operations and to reset the EOC processor to its initial state.
- 4) *Unable to comply acknowledgement:* This will be the confirmation that the NT1 has validated the receipt of an EOC message, but that the EOC message is not in the menu of the NT1.

- 5) *Request corrupt CRC*: This message requests the sending of corrupt CRCS toward the network, until cancelled with Return to Normal.
- 6) *Notify of corrupted CRC*: This message notifies the NT1 that intentionally corrupted CRCS will be sent from the network until cancellation is indicated by Return to Normal.
- 7) *Hold state*: This message is sent by the network to maintain the NT1 EOC processor and any active EOC controlled operations in their present state. This message may also be sent by the NT1 toward the network to indicate that the NT1 has received an EOC frame with an improper address.

II.8.3.3.5 Codes for required EOC functions

Table II-2/G.961 shows the codes for each of the EOC functions defined in § II.8.3.3.4 above.

TABLE II-2/G.961

Messages required for command response EOC mode

Message	Message code	Origin (o) & destination (d)	
		Network	NT1
Operate 2B + D loopback	0101 0000	o	d
Operate B ₁ -channel loopback	0101 0001	o	d
Operate B ₂ -channel loopback	0101 0010	o	d
Request corrupted CRC	0101 0011	o	d
Notify of corrupted CRC	0101 0100	o	d
Return to normal	1111 1111	o	d
Hold state	0000 0000	d/o	o/d
Unable to comply acknowledgement	1010 1010	d	o

Sixty-four EOC messages have been reserved for non-standard applications in the following four blocks of 16 codes each (x is ONE or ZERO): 0100 xxxx, 0011 xxxx, 0010 xxxx, 0001 xxxx. All remaining codes not defined in Table II-2/G.961 and not reserved for non-standard applications are reserved for future standardization. Thus, 184 codes associated with the NT1 (000) and broadcast (111) addresses, are available for future standardization, i.e., 256 total codes minus 8 defined codes from the table minus 64 codes for non-standard applications.

Note – The reservation of codes for non-standard applications does not in any way endorse their use. Any use of such messages shall not interfere with the EOC protocol. An NT1 and an LT that support messages for non-standard applications may not function properly together.

II.9 Scrambling

The data stream in each direction of transmission shall be scrambled with a 23rd-order polynomial (see Figure II-5/G.961) prior to the insertion of FW.

In the LT-NT1 direction the polynomial shall be:

$$1 \oplus x^{-5} \oplus x^{-23}$$

where

\oplus = modulo 2 summation.

In the NT1-LT direction the polynomial shall be:

$$1 \oplus x^{-18} \oplus x^{-23}$$

where

\oplus = modulo 2 summation.

The binary data stream shall be recovered in the receiver by applying the same polynomial to the scrambled data as was used in the transmitter.

Note – Binary ONES and ZEROS entering the NT1 receiver from the interface at reference point T or entering the LT side transceiver from the network must appear as binary ONES and ZEROS respectively, at the input of the scrambler. Also, during transmission/reception of the frame word or inverted frame word, the state of the scrambler must remain unchanged. (Caution: It is common for the input bits to be all ONES, e.g., during idle periods or during start-up. For the ONES to become scrambled, the initial state of the scrambling shift register must not be all 1s.)

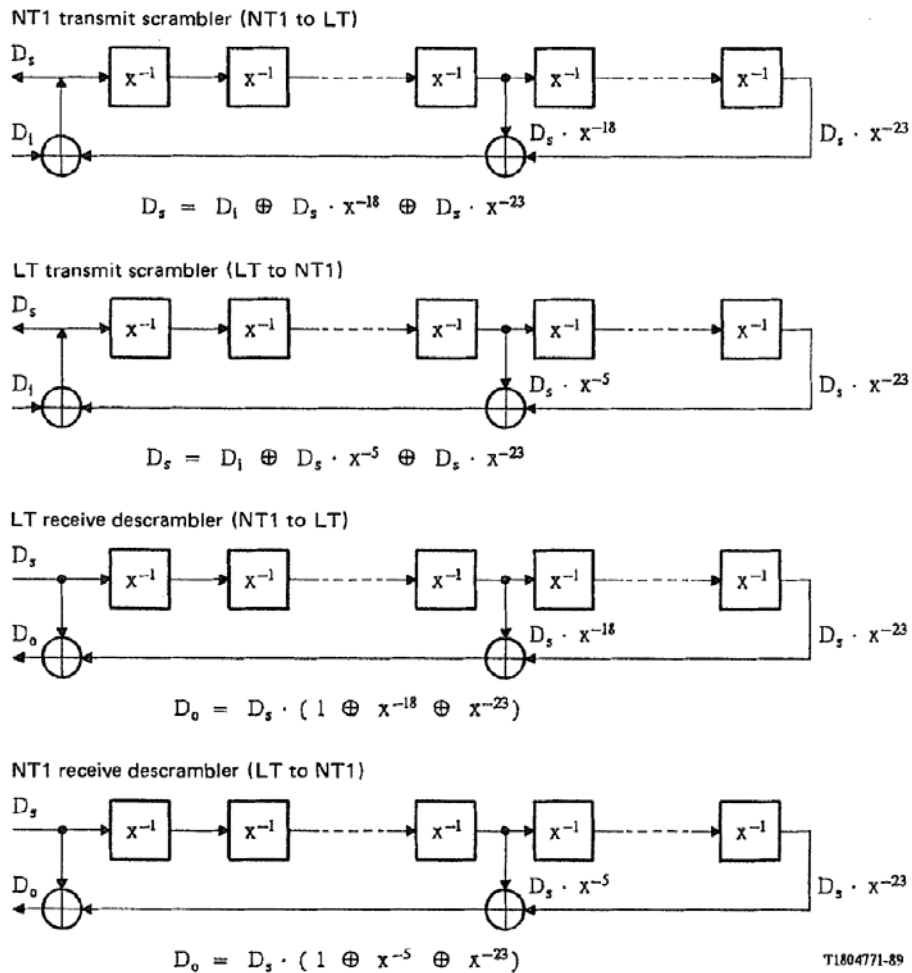

FIGURE II-5/G.961

Scrambler and descrambler

This section gives requirements and examples supporting activation/deactivation requests, indicators of activation and deactivation, and indicators of errors. The transmission system is capable of loopbacks but these are not illustrated by examples. The transmission system is also capable of being activated without activating the interface at reference point T. There are no provisions for the support of activation of the transmission system without activating the interface at reference point T, but such a capability is not precluded (e.g., by use of spare CL channel bits).

The following definitions are for the purpose of clarifying requirements that are to follow:

- 1) *Start-up*: A process characterized by a sequence of signals produced by the LT and by the NT1. Start-up results in establishment of the master-slave mode, i.e., synchronization of the receivers and the training of equalizers and echo cancelers to the point that two-way transmission requirements are met.
- 2) *Warm start*: The start-up process that applies to transceivers meeting the optional warm-start activation-time requirements after they have once been synchronized and have subsequently responded to a deactivation request. Warm start applies only if there have been no changes in line characteristics and equipment. Transceivers that meet warm-start requirements are called warm-start transceivers.
- 3) *Cold-start*: The start-up process that applies to transceivers that either do not meet optional warm-start activation-time requirements, or have not been continuously in a deactive state that resulted from a deactivation request to the NT1. Cold start also applies if there have been changes in line characteristics or equipment or both. A cold start shall always start from the RESET state.
- 4) *Cold-start-only (CSO)*: NT1 transceivers that do not meet optional warm-start activation-time requirements (see § II.10.6) are called cold-start-only transceivers.
- 5) *Reset*: The reset state consists of two sub-states: the receive reset and the full reset states. In other sections of this Recommendation, the term reset is used to refer to the full reset state.

Reset has no implications about the state of convergence of the equalizer or echo canceler coefficients of the transceiver. The reset states are applicable to cold-start-only as well as warm-start transceivers.

For specific transceiver implementations, reset states (or sub-states) may mean different and possibly multiple internal states.

- 6) *Full Reset*: The full reset state is one in which a transceiver has detected the loss of signal from the far-end and is not transmitting (sending signal to the loop).

The full reset state shall also be entered following power-up.

While in full reset, NT1s may initiate transmission only to request service. Under all other conditions, where the interface has been deactivated, the NT1s shall remain quiet, i.e., they shall not start transmitting any signal until the NT1 has received the TL signal from the network.

- 7) *Receive reset*: The receive reset state is a transient state in which NT1 has detected the loss of signal from the far-end and is not transmitting (sending signal to the loop) and, in addition, is not permitted to initiate the start-up sequence (send wake-up tone) but shall be capable of responding to the start-up sequence (detecting wake-up tone). An NT1 must remain in this state for at least 40 ms, after detecting the loss of received signal, as specified in § II.10.1.5.2 and II.10.2, after which time, the transceiver shall enter the full reset state.

II.10.1 *Signals used for activation*

II.10.1.1 *Signals during start-up*

Figure II-6/G.961 defines the signals produced by the transceivers during start-up. These signals apply during both types of start-up; i.e., cold start, and warm start. During start-up, all signals at the interface shall consist of sequences of symbols of the shape defined in § II.12.2.

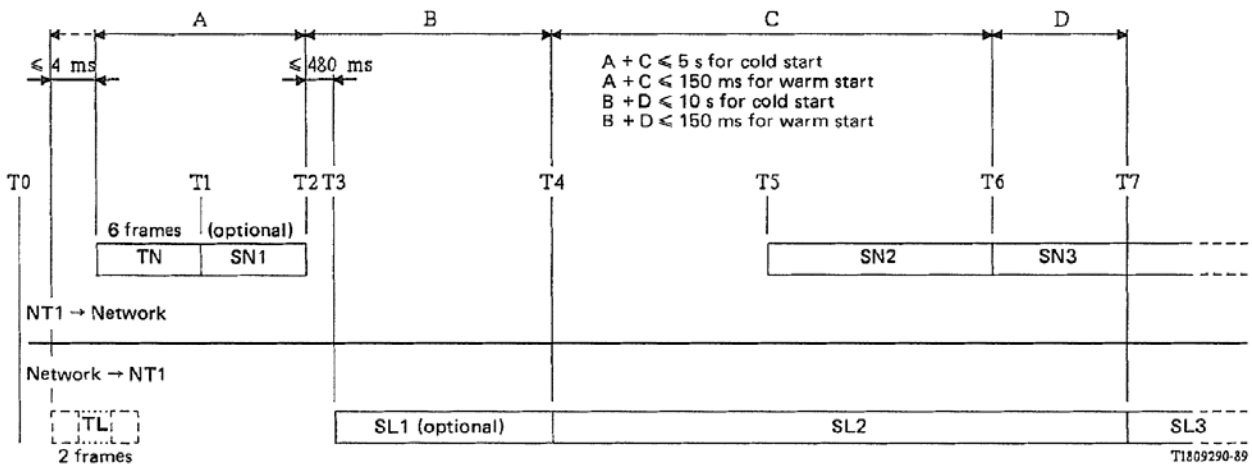

Time description of event or state:

- T0 Reset state.
- T1 Network and NT1 are awake.
- T2 NT1 discontinues transmission, indicating that the NT1 is ready to receive signal.
- T3 Network responds to termination of signal and begins transmitting signal toward the NT1.
- T4 Network begins transmitting SL2 toward the NT1, indicating that the network is ready to receive SN2.
- T5 NT1 begins transmitting SN2 toward the network, indicating that NT1 has acquired FW frame and detected SL2.
- T6 NT1 has acquired multiframe marker, and is fully operational.
- T7 Network has acquired multiframe marker, and is fully operational.

FIGURE II-6/G.961

State sequence for transceiver start-up

With the exception of the wake-up tones (TN and TL), the scrambler shall be used in the normal way in formulating the signals. For example, Figure II-7/G.961 shows ONEs for B and D channel bits and the overhead bits in the signal SN1. These ONEs are scrambled before coding, producing random pulses in these positions at the interface.

Except where noted otherwise in Figure II-7/G.961, all the pulse sequences, are framed and multiframed in accordance with the normal frame structure shown in Figures II-1/G.961, II-2/G.961, and II-3/G.961, and all pulses represent scrambled bits except those in the frame word. The signals TN and TL are 10 kHz tones generated by repeating the following unscrambled and unframed symbol pattern:

... +3 +3 +3 +3 -3 -3 -3 -3 ...

II.10.1.2 *Line rate during start-up*

During start-up, the network shall produce symbols at the nominal line rate within the tolerance specified in § II.2.1.2.

The symbol rate from the NT1 shall be 80 kbauds \pm 100 ppm.

Signal	Frame word (FW)	Multiframe (IFW)	2B + D	M	Start	Stop	Time (frames)
TN	± 3‡	± 3‡	± 3‡	± 3‡	†	†	6
SN1	Present	Absent	1	1	T1	T2	—
SN2	Present	Absent	1	1	T5	T6	—
SN3	Present	Present	Normal ⁺	Normal	T6	*	—
TL	± 3‡	± 3‡	± 3‡	± 3‡	†	†	2
SL1	Present	Absent	1	1	T3	T4	—
SL2	Present	Present	0	Normal	T4	T7	—
SL3	Present	Present	Normal ⁺	Normal	T7	*	—

‡ Tones have alternating pattern of four +3 symbols followed by four –3 symbols, and no FW

† See Figure II-6/G.961 and § II.10.1.3 for start and/or stop time of this signal

TN, TL Tones produced by NT1 or LT, respectively (see § II.10.1.1)

SNx, SLx Pulse patterns produced by NT1 or LT, respectively

Tx Notation refers to transition instants defined in Figure II-6/G.961

Absent Under Multiframe this notation means only that FW is transmitted instead of IFW

Normal Normal means that the M bits are transmitted onto the 2-wire line as required during normal operation; e.g., valid CRC bits, EOC bits, and indicator bits are transmitted

Normal⁺ Except to perform a loopback, 2B + D bits shall remain in the previous state (SN2 or SL2) until both act bits indicate full transparency of the B and D channels (i.e., the 2B + D bits of SN3 and SL3 shall remain set to ONE and ZERO, respectively, until transparency is achieved at both ends of the DLL)

* Signals SN3 and SL3 continue indefinitely (or until deactivation)

FIGURE II-7/G.961

Definitions of signals during start-up

II.10.1.3 *Start-up sequence*

Figure II-6/G.961 shows the sequence of signals at the interface that are generated by the transceivers. The transition points in the sequence are also defined in Figure II-7/G.961. For further information on the events at the interface at reference point T, the reader is referred to Recommendation I.430.

II.10.1.4 *Wake-up*

When transceivers meeting the optional warm-start activation-time requirements, or when cold-start-only NT1s having the optional capability of initiating start-up, are in the RESET state or are deactive as a result of responding to a deactivation request, either transceiver may initiate start-up by sending a tone as defined in Figure II-7/G.961.

II.10.1.5 *Progress indicators*

II.10.1.5.1 *Activation*

In the NT1 to LT direction, the act bit remains set to ZERO until the customer equipment indicates progress in getting ready to transmit. The corresponding action at the T reference point in the customer equipment is receipt of the signal INFO3. To communicate this progress indication, act from the NT1 is set to ONE. Assuming INFO3 occurs before T6 and T7, this progress indication shall not affect overhead symbols at the interface until T6, when the NT1 overhead bits are allowed to be normal, and may not be detected by the LT until T7.

After event T7 (Figure II-6/G.961) and after act = ONE is received from the NT1, the LT sets the act bit to ONE to communicate readiness for layer 2 communication (see § II.8.3.2.2).

II.10.1.5.2 *Deactivation*

Transceivers in the active state that meet optional warm-start activation-time requirements shall cease transmission on the basis of the DEA bit (see § II.8.3.2.3) and subsequent loss of received signal. The DEA bit from the LT shall be set to ONE before activation is initiated. The LT shall announce deactivation by setting DEA to ZERO.

The LT shall send DEA = ZERO in at least three multiframes before ceasing transmission. It shall cease transmission before sending a DEA bit in the multiframe following the multiframe in which DEA = ZERO is sent the last time. During the multiframes with DEA = ZERO the NT1 has time to prepare for deactivation. The NT1 shall, upon the detection of loss of signal from the LT, cease transmission, enter the receive reset state and deactivate. Its response time to a loss of received signal shall be such that the NT1 will enter the receive reset state within 40 ms. of the occurrence of the transition to no signal at its interface. As specified in the definitions given at the beginning of §II-10, it shall not initiate the transmission of wake-up tone for a period of at least 40 ms. after it ceases transmission and then it shall enter the full reset state. The LT shall enter the full reset state upon the detection of the loss of received signal.

LT transceivers not implementing optional warm-start activation-time requirements shall continuously set DEA to ONE.

II.10.2 *Timers*

Timers shall be used to determine entry into the reset states. Upon the occurrence of any of the following conditions:

- 1) failure to complete start-up within 15 s. (warm or cold start),
- 2) loss of received signal for more than 480 ms., or
- 3) loss of synchronization for more than 480 ms.,

a transceiver shall respond as follows: Upon satisfying conditions 1) or 3), it shall cease transmission and then, upon the subsequent detection of the loss of received signal, the transceiver shall enter the receive reset state. Its response time to a loss of signal (after conditions 1) or 2) have been satisfied) shall be such that it shall enter the receive reset state and be capable of responding to the initiation of wake-up tone by the far-end transceiver within 40 ms. after the far end transceiver ceases transmission. Upon satisfying condition 2), the transceiver shall immediately enter the receive reset state. As specified in part 7) of § II.10, a transceiver shall remain in the receive reset state for at least 40 ms., after which it shall enter the full reset state. The transceiver may not initiate transmission of wake-up tone in the receive reset state.

For conditions 2) and 3), the requirements apply to transceivers after start up, i.e., after multiframe synchronization is achieved (see T6 and T7 in Figure II-6/G.961 for NT1 and LT transceivers, respectively).

In addition, an NT1 shall enter the full reset state if signal is not received within 480 ms. after it ceases the transmission of TN, or SN1 if it is sent (see T2 to T3 in Figures II-6/G.961 and II-7/G.961).

II.10.3 Description of the activation procedure

II.10.3.1 Activation from customer equipment

While the NT1 and LT remain in the deactive state as a result of receiving and responding to a deactivation request, or while they are in RESET, a request for activation from the customer equipment shall result in the TN signal (tone) being sent from the NT1 toward the LT. The LT, on receiving TN shall remain silent until detection of cessation of signal from the NT1. The rest of the sequence then follows as indicated in Figures II-6/G.961 and II-7/G.961. If the LT happens to try to activate at the same time it may send a TL tone during the TN tone without harm.

While in the reset state, NT1 may initiate transmission only to request service. Under all other conditions where the system has been deactivated, the NT1 shall remain quiet, i.e., they shall not start transmitting any signal until the NT1 has received the TL signal from the LT.

II.10.3.2 Activation from the network

While the NT1 and LT remain in the deactive state as a result of receiving and responding to a deactivation request, or while they are in RESET, a request for activation from the LT shall result in the TL signal being sent from the LT toward the NT1. The NT1, on receiving TL shall respond with TN within 4 ms from the beginning of TL. The rest of the sequence then follows as indicated in Figures II-6/G.961 and II-7/G.961.

II.10.3.3 Sequence charts

Examples of sequence charts for activation by both terminal and ET equipment are given in Figures II-8/G.961 and II-9/G.961.

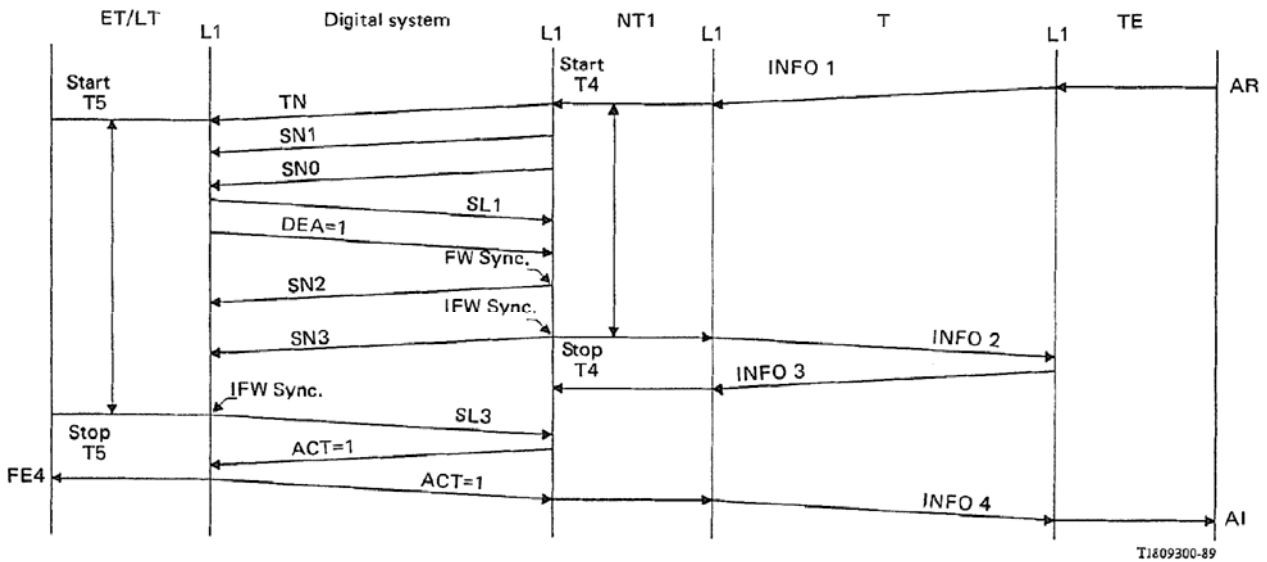

Note - Receipt of INFO 3 and SL3 at the NT1 can theoretically occur in either order.

FIGURE II-8/G.961

Activation initiated by terminal equipment

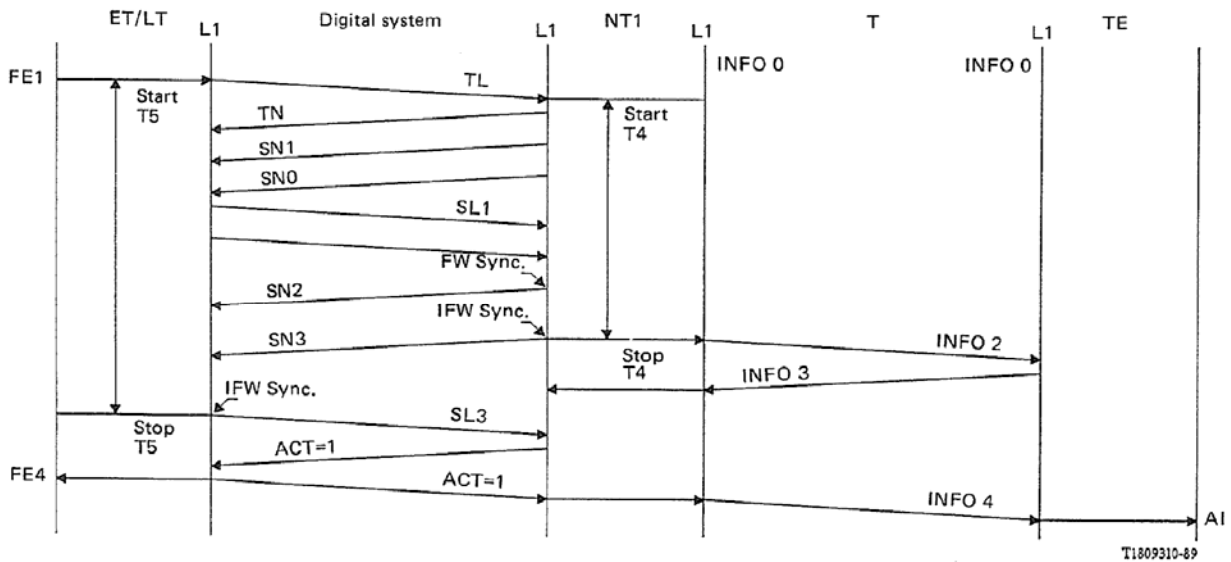

Note — Receipt of INFO 3 and SL3 at the NT1 can theoretically occur in either order.

FIGURE II-9/G.961

Activation initiated by the exchange

II.10.3.4 *Transparency*

Transparency of the transmission in both directions by the NT1 shall be provided after the NT achieves full operational status (T6), and both act = ONE from the LT and DEA = ONE. Full operational status of the NT1 means that the NT1 has:

- 1) acquired bit timing and frame synchronization from the incoming signal from the LT,
- 2) recognized the multiframe marker from the LT,
- 3) fully converged both its echo canceler and equalizer coefficients.

Transparency of the transmission in both directions at the LT shall be provided when the LT:

- 1) achieves full operational status (T7),
- 2) detects the presence of the multiframe marker from the NT1,
- 3) receives act = ONE from the NT1.

Full operational status at the LT means that the LT has:

- 1) acquired bit timing phase of the incoming signal from the NT1, and frame synchronization,
- 2) recognized the multiframe marker from the NT1,
- 3) fully converged both its echo canceler and equalizer coefficients.

After both the LT and the NT1 achieve transparency in both directions, the act bits shall continue to reflect the state of readiness of the LT and the terminal equipment for layer 2 communication. The act bit in the LT-to-NT1 direction shall reflect the status of the LT side of the interface. The act bit in the NT1-to-LT direction shall reflect the status of the NT1 side of the interface. Whenever either end, for any reason, loses its readiness to communicate at layer 2 (e.g., the terminal is unplugged), that end shall set its transmitted act bit to ZERO. A change of status of this bit shall be repeated in at least three consecutive transmitted multiframes.

II.10.4 State transition table for the NT1

Table II-3/G.961 provides an example of a state transition table for the NT1 as a function of INFOs, SIGs, and Timers.

TABLE II-3/G.961

State transition table for the NT1 as a function of INFOs, SIGs and timers

Event	State name	Power off	Full reset	Alerting	EC training	EC cnvrg'd	FW sync.	IFW sync.	Pending active	Active	Pending deact'n	Tear down	TE inactive	Rcv. reset	
	State code	NT0	NT1 (T0)	NT2	NT3 (T1)	NT4 (T2)	NT5 (T5)	NT6 (T6)	NT7	NT8	NT9	NT10	NT11	NT12	
	Tx (Note 6)	SN0 INFO 0	SN0 INFO 0	TN INFO 0	SN1 INFO 0	SN0 INFO 0	SN2 INFO 0	SN3 ACT=0 INFO 2	SN3 ACT=1 INFO 2	SN3 ACT=1 INFO 4	SN3 (Nota 7)	SN0 INFO 0	SN3 ACT=0 INFO 2	SN0 INFO 0	
Power on		NT1	-	-	-	-	-	-	-	-	-	-	-	-	
Loss of power		-	NT0	NT0	NT0	NT0	NT0	NT0	NT0	NT0	NT0	NT0	NT0	NT0	
Received T INFO 1 signal (Notes 1 and 2)		/	ST.T4 NT2	-	-	-	-	-	-	/	/	-	/	-	
Received T INFO 3 signal (Notes 1 and 3)		/	/	/	/	/	/	NT7	-	-	-	-	NT7	/	
Received T INFO 0 signal (Notes 1 and 4)		/	-	-	-	-	-	-	NT11	NT11	-	-	/	-	
End of tone TN (9 ms)		/	/	TR3	-	/	/	/	/	/	/	/	/	/	
Received tone TL		/	ST.T4 NT2	-	/	/	/	/	/	/	/	/	/	ST.T4 STP.T 6 NT2	
Echo canceler converged		/	-	-	NT4	-	-	-	-	-	-	-	-	-	
Basic frame sync (FW)		/	/	/	/	NT5	-	-	-	-	-	-	-	-	
Multiframe sync (IFW)		/	/	/	/	/	STP.T4 NT6	-	-	-	-	-	-	-	
Received DEA = 0 (Note 6)		/	/	/	/	/	/	NT9	NT9	NT9	-	-	NT9	-	
Received ACT = 0		/	/	/	/	/	/	-	-	NT7	-	-	-	-	
Received ACT = 1 and DEA = 1		/	/	/	/	/	/	-	NT8 AI	-	-	-	-	-	
Loss of synchronization (> 480 ms)		/	/	/	/	/	/	NT10	NT10	NT10	-	-	NT10	-	
Loss of signal (> 480 ms)		/	/	/	/	/	ST.T6 NT1	ST.T6 NT12	ST.T6 NT12	ST.T6 NT12	ST.T6 NT12	/	/	ST.T6 NT12	-
Expiry of timer T4 (15 seconds)		/	-	NT10	NT10	NT10	NT10	/	/	/	/	-	/	-	
Loss of signal (< 40 ms)		/	/	/	/	/	/	/	/	/	ST.T6 NT12	ST.T6 NT12	/	/	
Expiry of timer T6 (40 ms)		/	-	/	/	/	/	/	/	/	/	/	/	NT1	

Note – For symbols and abbreviations, see Table II-4/G.961.

II.10.5 State transition table for the LT

Table II-4/G.961 provides an example of a state transition table for the LT as a function of FEs, SIGs, and Timers.

TABLE II-4/G.732

State transition table for the LT as a function of FEs, SIGs and timers

Event	State name	Power off	Full reset	Alerting	EC training	EC cnvrg'd	FW sync.	IFW sync.	Pending active	Active	Pending deact'n	Tear down	TE inactive	Rev. reset
	State code	LT0	LT1 (T0)	LT2	LT3 (T1)	LT4 (T2)	LT5 (T5)	LT6 (T6)	LT7	LT8	LT9	LT10	LT11	LT12
	Tx	SL0	SL0	LT	SL0	SL1	SL2 DEA=1 ACT=0	SL2 DEA=1 ACT=0	SL3 DEA=1 ACT=0	SL3 DEA=1 ACT=1	SL3 DEA=0 ACT=0	SL0	SL0	SL0
Power on		LT1	-	-	-	-	-	-	-	-	-	-	-	-
Loss of power		-	TL0 EF7	TL0 EF7	LT0 EF7	LT0 EF7	LT0 EF7	LT0 EF7	LT0 EF7	LT0 EF7	LT0 EF7	LT0 EF7	LT0 EF7	LT0
Activation request (FE1)		/	ST.T5 LT2	-	-	-	-	-	-	/	/	-	-	-
Deactivation request (FE5) (Note 8)		/	/	/	/	/	/	TR7	-	-	-	-	TR7	/
End of tone TL (3 ms)		/	/	LT3	-	/	/	/	/	/	/	/	/	/
Received tone TN		/	ST.T5 LT3	-	-	/	/	/	/	/	/	/	/	ST.T5 STP.T 7 LT3
Loss of signal energy		/	-	-	LT4	-	/	/	/	/	/	/	/	-
Echo canceler converged		/	-	-	-	LT5	-	-	-	-	-	-	-	-
Basic frame sync. (FW)		/	/	/	/	/	LT6	-	-	-	-	-	-	-
Multiframe sync. (IFW)		/	/	/	/	/	/	STP.T5 LT7	-	-	-	-	-	-
Received ACT = 0		/	/	/	/	/	/	/	-	LT7 EF6,7	-	-	-	-
Received ACT = 1		/	/	/	/	/	/	/	LT8 EF4	-	-	-	-	-
Loss of synchronization (> 480 ms)		/	/	/	/	/	/	/	LT10 EF7	LT10 EF6,7	-	-	-	-
Loss of signal (> 480 ms)		/	/	/	/	/	/	ST.T7 LT12 EF7	ST.T7 LT12 EF7	ST.T7 LT12 EF6,7	-	/	/	/
End of last multiframe with DEA = 0 (Note 9)		/	/	/	/	/	/	/	/	/	LT11	/	/	/
Expiry of timer T5 (15 seconds)		/	-	LT10 EF7	LT10 EF7	LT10 EF7	LT10 EF7	LT10 EF7	/	-	/	-	/	/
Loss of signal (< 40 ms)		/	-	/	/	/	/	/	/	/	/	ST.T7 LT12	LT1	-
Expiry of timer T7 (40 ms)		/	/	/	/	/	/	/	/	/	/	/	/	LT1

Symbols, abbreviations, and Notes for Tables II-3/G.961 and II-4/G.961

–	No change, no action
/	Impossible situation
FE1	Function element – corresponds to primitive Activation request – PH-AR
FE4	Function element – corresponds to primitive Activation indication – PH/MPH-AI
FE5	Function element – corresponds to primitive Deactivation request – MPH-DR
FE6	Function element – corresponds to primitive Deactivation indication – MPH-DI
FE7	Function element – corresponds to primitive Error indication
NTn	Go to state “NTn”
LTn	Go to state “LTn”
ST.Tn	Start timer Tn
STP.Tn	Stop timer Tn
SL0	No signal

Note 1 – These events are initiated by the “G” Finite State Matrix (FSM), as defined in Recommendation I.430, and communicated to the “NT” FSM through messages.

Note 2 – This condition acts as an “Activation Request” event.

Note 3 – This condition indicates that the user data path (2B + D channels) in the TE-to-NT1 direction is transparent to user data.

Note 4 – This condition indicates that the user data path (2B + D channels) in the TE-to-NT1 direction is not transparent to user data.

Note 5 – This event takes priority over received act = ZERO for warm-start NT1s. This event could be ignored for NT1s not wishing to deactivate (cold-start-only NT1s).

Note 6 – Although the INFO signals at the T reference point are shown as transmit signals in the “NT” FSM, the “NT” FSM does not directly control these signals. They are included for information only.

Note 7 – The signals output in this state remain unchanged from signals output during the preceding state (e.g., act = ZERO if NT6 or NT11 preceded, or act = ONE if NT7 or NT8 preceded).

Note 8 – This event will cause deactivation of the NT1 independent of whether the transmitter is cold-start-only or warm-start.

Note 9 – This event must occur after receiving at least three multiframes. See § II.10.1.5.2.

II.10.6 *Activation times*

The LT and the NT1 shall complete the start-up process, including synchronization and training of equalizers to the point of meeting performance criteria within the following lengths of time: Cold-start-only transceivers shall synchronize within 15 s. Transceivers meeting optional warm-start activation-time requirements shall synchronize within 300 ms. on warm starts and within 15 s on cold starts. The 15-second cold-start time requirement is apportioned such that the NT1 is allowed 5 s. and the LT is allowed 10 s. For warm starts the 300 ms. start-up time requirement is apportioned equally between the NT1 and the LT, 150 ms. each. See Figure II-6/G.961 for details.

Note – The 300 ms. requirement applies to laboratory tests only. No 300 ms. timer is involved in actual in-service loops. (See definitions in § II.10 for warm and cold starts.)

As indicated in Figure II-6/G.961, the start time requirements cover the time span from wake-up tone to T7, and do not include time for activation of customer terminal equipment. All activation times apply only to the DLL, and do not apply to the entire customer access link where carrier systems may be involved.

Note – The value in Recommendation G.960 is 10 s. This is a 95% value.

II.11 *Jitter*

To assure support of the jitter requirements of Recommendation I.430, the jitter of the timing signal recovered at the clock of the NT1 shall not exceed the limits given in Figure 9/I.430 and § 8.3.1 of Recommendation I.430. Jitter tolerances are intended to ensure that the limits of Recommendation I.430 are supported by the jitter limits of the transmission system on subscriber lines. The jitter limits given below must be satisfied regardless of the length of the subscriber line and the inclusion of one repeater, provided that they are covered by the transmission media characteristics. The limits must be met regardless of the transmitted signal. In this Recommendation, jitter is specified in terms of unit intervals (UI) of the nominal 80 kbauds signal (12.5 μ s.).

II.11.1 *Input signal jitter tolerance*

The NT1 shall meet the performance objectives with wander/jitter at the maximum magnitude indicated in Figure II-10/G.961, for single jitter frequencies in the range of 0.1 Hz to 20 kHz, superimposed on the test signal source with the received signal symbol rate in the range of 80 kbauds \pm 5 ppm. The NT1 shall also meet the performance objectives with wander per day of up to 1.44 UI peak-to-peak where the maximum rate of change of phase is 0.06 UI/hour.

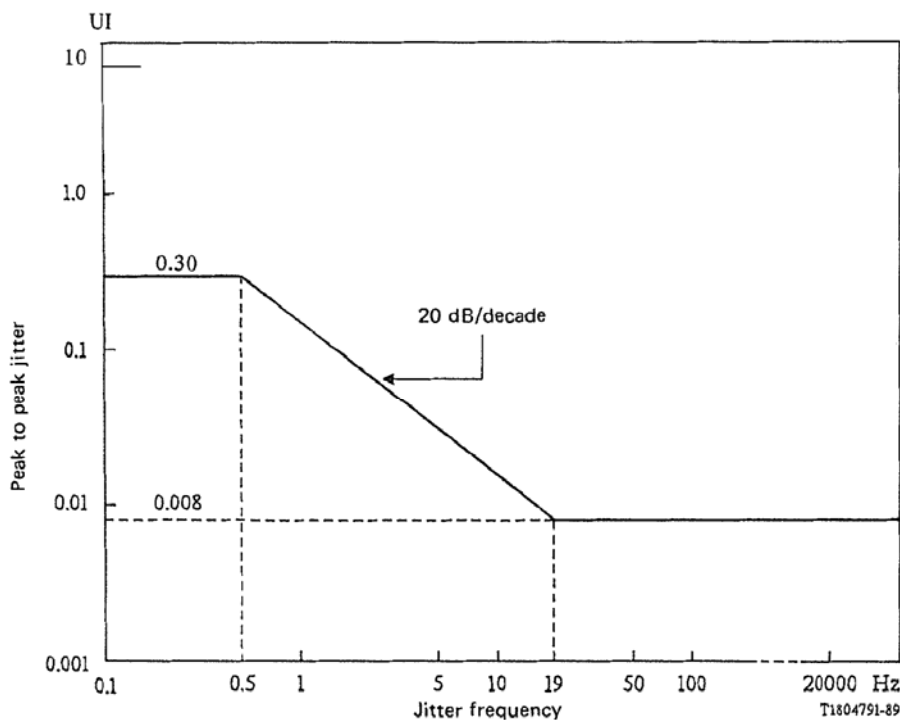

Note - Unit interval (UI) = 12.5 μ s.

FIGURE II-10/G.961

Permissible sinusoidal NT1 input signal jitter

II.11.2 *NT1 output jitter limitations*

With the wander/jitter as specified in § II.11.1, except as noted, superimposed on the NT1 input signal, the jitter on the transmitted signal from the NT1 towards the LT shall conform to the following, with the received signal symbol rate in the range of 80 kbauds \pm 5 ppm, as described in § II.2:

- 1) The jitter shall be equal to or less than 0.04 UI peak-to-peak and less than 0.01 UI rms when measured with a high-pass filter having a 6 dB/octave roll-off below 100 Hz.

- 2) The jitter in the phase of the output signal (the signal transmitted towards the LT) relative to the phase of the input signal (from the LT) shall not exceed 0.05 UI peak-to-peak and 0.015 UI rms when measured with a band-pass filter having a 6 dB/octave roll-off above 40 Hz and below 1.0 Hz. (Note that the 1.0 Hz cut-off assures that the average difference in the phase of the input and output signals is subtracted.) This requirement applies with superimposed jitter in the phase of the input signal as specified in § II.11.1 for single frequencies up to 19 Hz.
- 3) The maximum (peak) departure of the phase of the output signal from its nominal difference (long term average) from the phase of the input signal (from the LT) shall not exceed 0.1 UI. This requirement applies during normal operation including following a “warm start”. (Note that this means that, if deactivated and subsequently activated in conformance with the “warm start” requirements, the long term average difference in phase of the output signal from the phase of the input signal shall be essentially unchanged.)

II.11.3 *Test conditions for jitter measurements*

Due to bidirectional transmission on the 2-wire and due to severe intersymbol interference, no well defined signal transitions are available at the NT1 2-wire point.

Two possible solutions are proposed:

- 1) A test point in the NT1 is provided to measure jitter with an undisturbed signal.
- 2) A standard LT transceiver including an artificial transmission line is defined as a test instrument.

II.12 *Transmitter output characteristics of NT1 and LT*

The following specifications apply with a load impedance of 135 ohms resistive over a frequency band of 0 Hz to 160 kHz.

II.12.1 *Pulse amplitude*

The nominal peak of the largest pulse shall be 2.5 Volts (see Figure II-11/G.961).

II.12.2 *Pulse shape*

The transmitted pulse shall have the shape specified in Figure II-11/G.961. The pulse mask for the four quaternary symbols shall be obtained by multiplying the normalized pulse mask shown in Figure II-11/G.961 by 2.5 V, 5/6 V, -5/6 V or -2.5 V. When the signal consists of a framed sequence of symbols with a synchronization word and equiprobable symbols in all other positions, the nominal average power is 13.5 dBm.

II.12.3 *Signal power*

The average power of a signal consisting of a framed sequence of symbols with a frame word and equiprobable symbols at all other positions should be between 13.0 dBm and 14.0 dBm over the frequency band from 0 Hz to 80 kHz.

II.12.4 *Power spectral density*

The upper bound of the power spectral density of the transmitted signal shall be as shown in Figure II-12/G.961.

II.12.5 *Transmitted linearity*

II.12.5.1 *Requirements*

This is a measure of the deviations from ideal pulse heights and the individual pulse non-linearity. The transmitted and received signals shall have sufficient linearity so that the residual rms non-linearity is at least 36 dB below the rms signal at the interface.

Normalized level		Quaternary symbols			
		+3	+1	-1	-3
A	0.01	0.025 V	0.00833 V	-0.00833 V	-0.025 V
B	1.05	2.625 V	0.8750 V	-0.8750 V	-2.625 V
C	1.00	2.5 V	5/6 V	-0.5/6 V	-2.5 V
D	0.95	2.275 V	0.79167 V	-0.79167 V	-2.275 V
E	0.03	0.075 V	0.025 V	-0.025 V	-0.075 V
F	-0.01	-0.025 V	-0.00833 V	0.00833 V	0.025 V
G	-0.12	-0.3 V	-0.1 V	0.1 V	0.3 V
H	-0.05	-0.125 V	-0.04167 V	0.04167 V	0.125 V

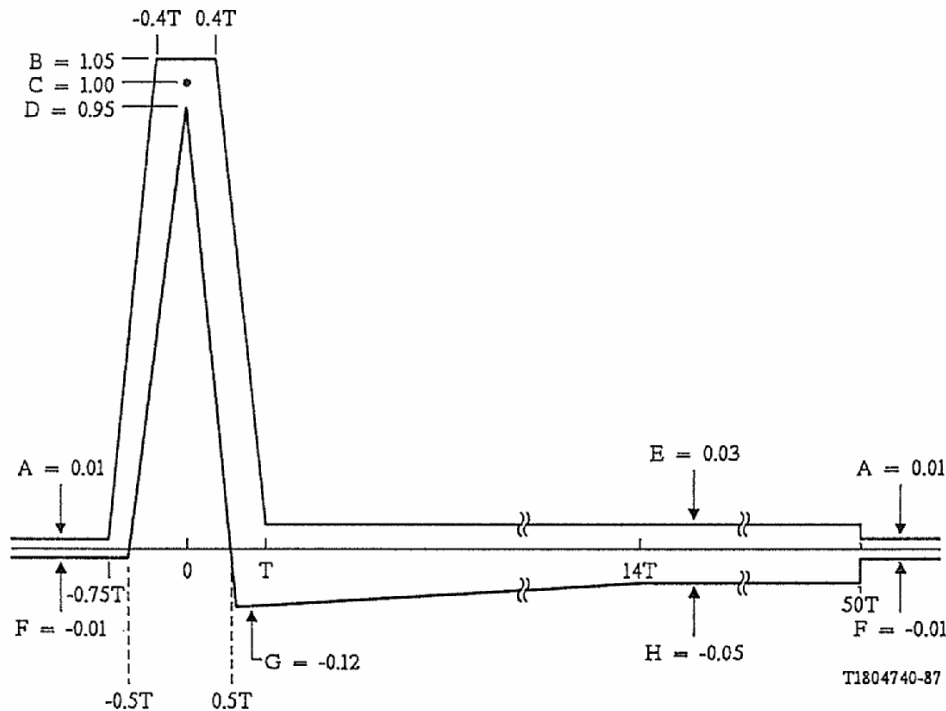

FIGURE II-11/G.961

Normalized output pulse from NT1 or LT

II.12.5.2 *Linearity test method*

With the transceiver (LT or NT1) terminated in a 135/ohm resistance through a zero-length loop, and driven by an arbitrary binary sequence, the voltage appearing across the resistance is filtered (anti-alias), sampled and converted to digital form (V_{out}) with a precision of no less than 12 bits (see Figure II-13/G.961). These samples are compared with the output of an adjustable, linear filter, the input of which is the scrambled, framed, and linearly encoded transmitter input. The signals at the subtractor may both be in digital form, or they may both be in analog form.

The linear digital filter input (“Quaternary Input Data” in Figure II-13/G.961) can be considered a linearity standard. It may be produced from the transmitter output by an errorless receiver (with no descrambler), or from the scrambled transmitter input data if it is available. If the samples input to the adjustable filter are available in digital form, no additional A/D converter is required. Whether analog or digital, these samples are required to be in the ratio 3:1:-1:-3, to an accuracy of at least 12 bits.

The sampling rate of the samplers and filters may be higher than the symbol rate, and generally will be several times the symbol rate for good accuracy. Alternatively, the sample rate may be at the symbol rate, but the rms values are obtained by averaging over all sample phases relative to the transmitter signal.

Because the anti-alias filter, sampler, and A/D converter operating on the transmitter output may introduce a loss or gain, proper calibration requires determining $\langle V_{out}^2 \rangle$ at the filter output, as shown in Figure II-13/G.961, rather than the mean-squared value of the transmitter output itself.

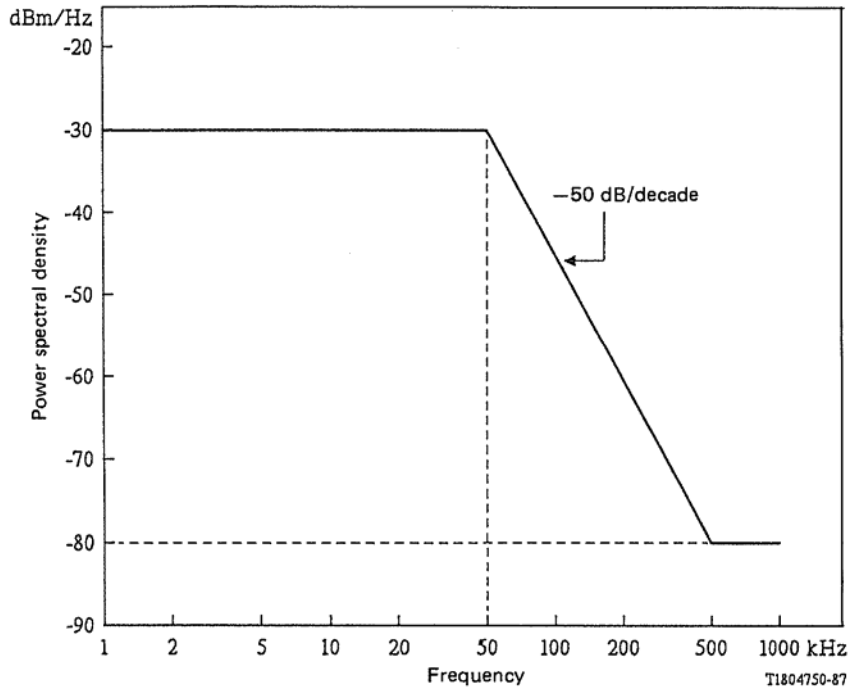

FIGURE II-12/G.961

Upper bound of power spectral density of signal from NT1 and LT

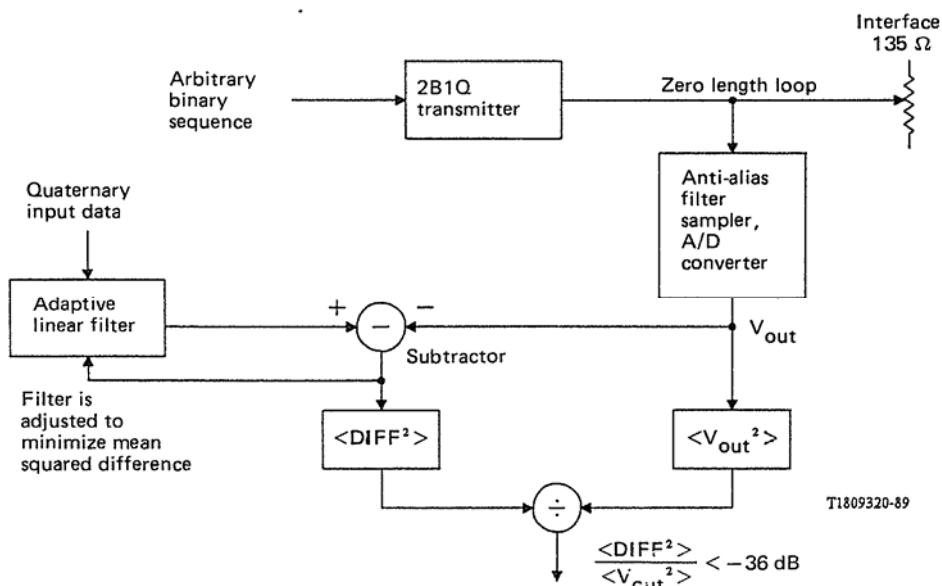

FIGURE II-13/G.961

Measurement of transmitter linearity

II.13 *Transmitter/receiver termination*

II.13.1 *Impedance*

The nominal driving point impedance at the interface toward the NT1 shall be 135 ohms.

II.13.2 *Return loss*

The return loss with respect to 135 ohms, over a frequency band from 1 kHz to 200 kHz, shall be as shown in Figure II-14.G.961.

II.13.3 *Longitudinal conversion loss*

II.13.3.1 *Longitudinal Balance*

The longitudinal balance (of impedance to ground) is given by:

$$LBal = 20 \log \left| \frac{e_l}{e_m} \right| \text{ dB}$$

where

e_l is the applied longitudinal voltage (referenced to the building green or green wire ground of the NT1).

e_m is the resultant metallic voltage appearing across a 135 ohms termination.

The balance shall be > 60 dB at frequencies up to 4 kHz and > 55 dB at higher frequencies up to 160 kHz.

Figure II-15/G.961 defines a measurement method for longitudinal balance. For direct use of this test configuration, measurement should be performed with the NT1 powered up but inactive (no transmitted signal).

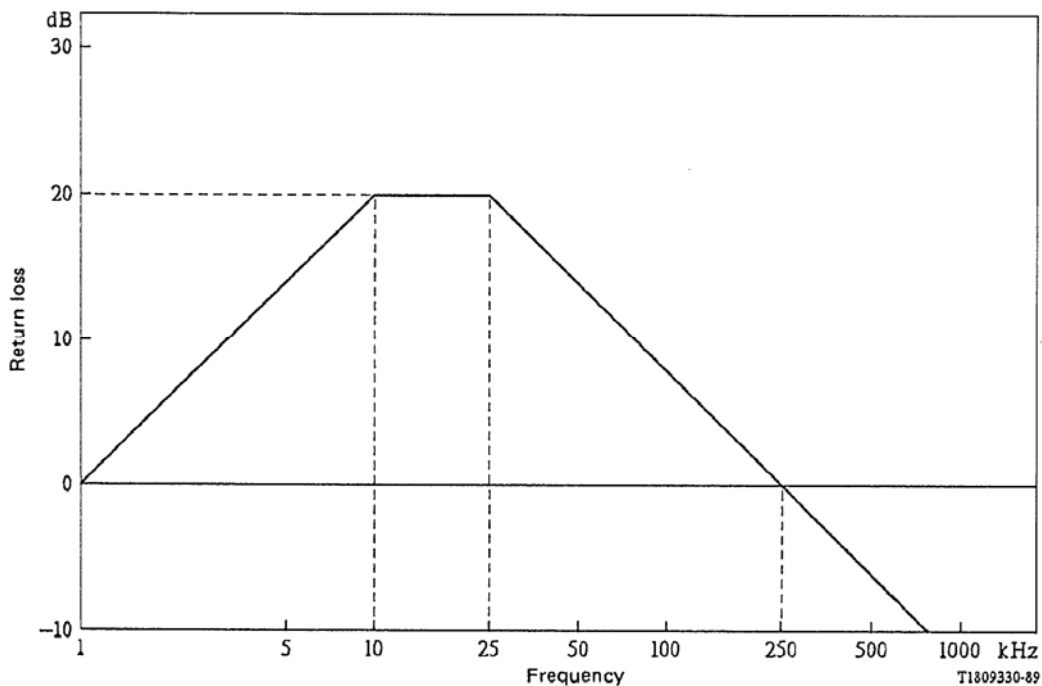
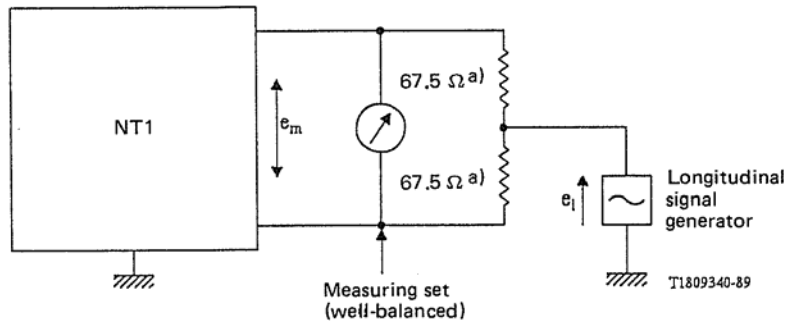

FIGURE II-14/G.961

Minimum return loss



a) These resistors to be matched to better than 0.03% tolerance.

FIGURE II-15/G.961

Measurement method for longitudinal balance

II.13.3.2 *Longitudinal output voltage*

The longitudinal component of the NT1 output signal shall have an rms voltage, in any 4 kHz bandwidth averaged in any 1 second period, less than -50 dBv over the frequency range 100 Hz to 170 kHz, and less than -80 dBv the range from 170 kHz to 270 kHz. Compliance with this limitation is required with a longitudinal termination having an impedance equal to or greater than a 100 ohm resistor in series with a 0.15 uF capacitor.

Figure II-16/G.961 defines a measurement method for longitudinal output voltage. For direct use of this test configuration, the NT1 should be able to generate a signal in the absence of a signal from the LT.

The ground reference for these measurements shall be the building ground.

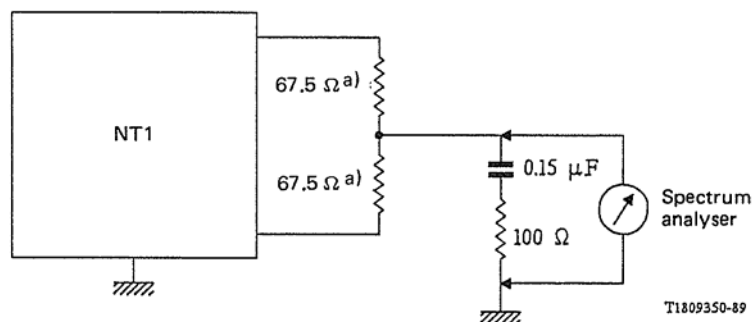

a) These resistors to be matched to better than 0.1% tolerance.

FIGURE II-16/G.961

Measurement method for longitudinal output voltage

APPENDIX III

(to Recommendation G.961)

Electrical characteristics of an AMI transmission system

III.0 *General*

The system will support the full duplex, transparent transmission of the two 64 kbit/s B channels and one 16 kbit/s D channel, as defined in Recommendation I.412. The bidirectional transmission over symmetric pair cables is based on the echo cancelling techniques. An extra 16 kbit/s capacity is added to the resulting 144 kbit/s data information, to provide a CL channel (for control, supervisory and maintenance purposes) and other transmission facilities.

The frames of the transmitted signal contain framewords which include a time period of absence of line signal. This frame format allows, when the relative offset between the frames in the two transmission direction is lesser than the values specified in § III.7, to simplify the timing recovery, the line equalizer setting and the echo canceller updating.

III.1 *Line code*

For both directions of transmission the line code is AMI.

The binary bit stream shall be coded according to the following rule:

- a binary ONE is represented by no line signal
- a binary ZERO is alternately represented as a positive or a negative pulse.

III.2 *Symbol rate*

The symbol rate is determined by the line code, the bit rate of the information stream and the frame structure. The symbol rate is 160 kbauds.

III.2.1 *Clock requirements*

III.2.1.1 *Free running NT1 clock accuracy*

The accuracy of the free running clock in the NT1 shall be ± 50 ppm.

III.2.1.2 *LT clock tolerance*

The NT1 and the LT shall accept a clock accuracy from the ET of ± 1 ppm.

III.3 *Frame structure*

The frame structure contains a frame word, 32 times (2B + D) and a CL channel, besides an auxiliary and a stop bit. In both transmission directions the general structure of the frame is as follows:

Frame word	A	4 [8 (2B + D) + CL]	P
------------	---	---------------------	---

A = Auxiliary bit

The A bit of the frame is used to distinguish the directions of transmission and to signal the correct establishment of the activation procedure by the polarity inversion.

P = Parity bit

The P bit is used to get an even number of binary ZEROs in the frame; so it is set to binary ZERO or binary ONE according to the number of binary ZEROs if the frame is odd or even respectively.

III.3.1 *Frame length*

The number of $(2B + D)$ slots in one frame is 32; whereas the number of CL bits is 4.

III.3.2 *Bit allocation in direction LT-NT1*

In Figure III-1/G.961 the bit allocation is given.

Bit position	Use				
1-58	Frame word				
59	Auxiliary bit				
60-67	B1 channel	}	First slot (2B + D)	} First block [8 (2B + D) + CL]	
68-75	B2 channel				
76-77	D channel				
.					
.					
.					
.					
186-193	B1 channel	}	Eighth slot (2B + D)		
194-201	B2 channel				
202-203	D channel				
204	CL channel				
.					
.					
.					
.					
492-493	B1 channel	}	First slot (2B + D)	} Fourth block [8 (2B + D) + CL]	
494-508	B2 channel				
509-510	D channel				
.					
.					
.					
621-628	B1 channel	}	Eighth slot (2B + D)		
629-636	B2 channel				
637-638	D channel				
639	CL channel				
640	Parity bit				

FIGURE III-1/G.961

Bit allocation in direction LT-NT1

III.3.3 *Bit allocation in direction NT1-LT*

Same as § III.3.2.

III.4 *Frame word*

The frame word is used to allocate bit positions to the $2B + D + CL$ channels and to the A and P bits. It may also be used for timing recovery, echo canceller updating and line equalizer setting.

III.4.1 *Frame word in direction LT-NTI*

The code for the frameword shall be 57 consecutive binary ONE (coded as line absence of signal) and one binary ZERO (positive line pulse).

III.4.2 *Frame word in direction NTI-LT*

Same as § III.4.1.

III.5 *Frame alignment procedure*

The frame alignment procedure shall be as follows:

III.5.1 *State 1: correct frame alignment*

To enter the correct alignment state the frame word, the auxiliary bit and the parity bit must be detected correctly three times consecutively.

III.5.2 *State 2: prealarm for frame alignment*

To enter the prealarm state it is sufficient not to detect the frame word, the auxiliary bit and the parity bit for one time.

III.5.3 *State 3: out of frame alignment*

To enter the out of alignment state eight consecutive negative checks of the condition defined under state 1 must be detected.

III.6 *Multiframe*

To enable bit allocation of the CL channel in more frames next to each other, a multiframe structure shall be used. The start of the multiframe is determined by the content of the CL channel in a frame word as described in § III.6.1. The total number of frames in a multiframe is 4.

III.6.1 *Multiframe word in direction NTI-LT*

The multiframe will be identified by detecting the CL channel bits. CL channel is synchronous with the frame, and the start of a multiframe is assumed when odd parity is verified on the four CL bits in a frame. There are four of CL bits in a frame, coded as follows:

<i>CL channel structure</i>				
I	I	I	O	First frame
I	I	I	P	Second frame
I	I	I	P	Third frame
P	P	P	P	Fourth frame

Where I stands for Information bits and P, O for parity check bits. The P bits of the fourth frame are dedicated to vertical parity of the previous frames, while O is the odd parity of the first frame. The parity evaluation is performed considering the binary ONE's. The first CL frame is also used for multiframe alignment. In the condition of out of multiframe alignment the CL channel shall be disregarded.

III.6.2 *Multiframe word in direction LT-NTI*

Same as § III.6.1.

III.6.3 *Multiframe alignment procedure*

The multiframe alignment is based on a correct detection of the parity (odd and even) of the CL channel. The correct multiframe alignment is assumed when the four parity bits satisfy the horizontal sequence Odd, Even, Even, Even and vertical sequence Even (see § III.6.1). When such sequence is not detected a prealarm multiframe alignment state is assumed, then if the correct detection is not available, out of multiframe alignment is assumed. From the state of out of multiframe alignment or from prealarm multiframe alignment condition only one correct detection of the right sequence enters the system in correct multiframe alignment state.

III.7 *Frame offset between LT-NT1 and NT1-LT frames*

The NT1 shall synchronize its frame with the frames received in the direction LT to NT1 and will transmit its frame with the offset specified in § III.7.1.

In LT the offset between the frames in the two transmission directions shall not exceed the value specified in § III.7.2.

III.7.1 *Relative frame position at the NT1 input output*

The first bit of each frame transmitted from a NT1 towards the LT shall be delayed, nominally, by 583 bit periods with respect to the first bit of the frame received from the LT. Figure III-2 /G.961 illustrated the relative bit positions for both transmitted and received frames.

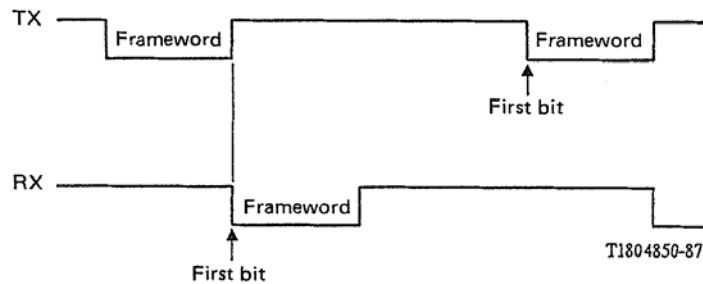

FIGURE III-2/G.961

Timing diagram in NT1

III.7.2 *Relative frame position at the LT input/output*

The time delay between the first bit of each frame transmitted from a LT towards the NT1 and the first bit of each frame received from NT1 shall not exceed 583+13 bit periods. Figure III-3/G.961 shows the relative bit positions for both transmitted and received frames.

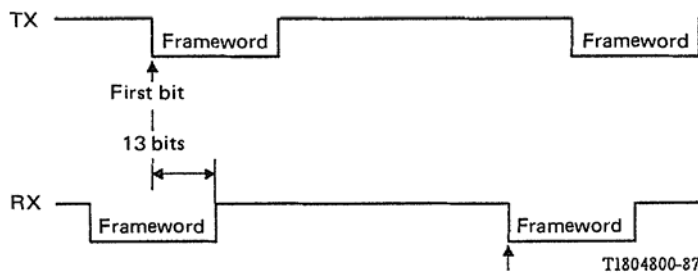

FIGURE III-3/G.961

Timing diagram in LT

III.8 *CL channel*

CL channel shall be used to carry information for activation/deactivation, testing and maintenance purposes.

III.8.1 *Bit rate*

The bit rate for the CL channel is 1 kbit/s.

III.8.2 *Structure*

The informations to be transmitted are organized in frames of 16 bit (four quadruplets in a multiframe). Each sixteen bits frame contains:

- 9 information bits;
- 7 bits for parity checks and error detection and multiframe alignment purposes.

Denoting by I the information bits and by O and P the bits for odd and even parity, the generic frame may be represented as indicated in § III.6.1.

III.8.2.1 *CL channel performance*

The performance of the CL channel shall be the following:

With a bit error rate of 10^{-3}

- the frame simulation probability shall be less than 10^{-10}
- the probability of not detecting a right frame in 100 ms shall be less than 10^{-10}

III.8.3 *Protocols and procedures*

The messages on the CL channel may be split into two categories, namely:

- a) messages concerned with the activation/deactivation procedure and spontaneous report of maintenance information not solicited by the ET.
- b) auxiliary messages for maintenance purposes. These functions imply actions that can be started only by the ET and that can be performed during the full active state.

The messages of the category a) are present in a continuous mode; this means that they are transmitted continuously on the CL channel until a new message has to be transmitted.

The messages used for the transmission of these messages allows the transmission of both single byte information and multi byte information.

The procedure, that may be started only by LT/ET, shall be as follows:

- The LT/ET sends in a continuous mode the first message containing the first information byte. The first information byte always contains the address of the destination equipment in a downstream direction (regenerator, NT1). The message is transmitted continuously until the reception of an acknowledged message from the destination equipment.
- The LT/ET sends, in the same way the following messages each containing a byte information. Each message sent by LT/ET is acknowledged by the destination equipment.
- The ET/LT sends an end-message which is acknowledged as any other message.
- When the destination equipment has to send answer information, the procedure is the same as above. In this case it is not necessary to provide the address as the destination equipment is LT/ET.

III.9 *Scrambling*

Scrambling will be applied on (2B + D + CL) channels. The scrambling polynomial is $1 \oplus x^{-9} \oplus x^{-11}$ in both transmission directions.

Scrambling with a two thresholds guard circuit is used to avoid long sequences of binary ONE's.

Figures III-4/G.961 and III-5/G.961 show the scrambling and descrambling circuit respectively.

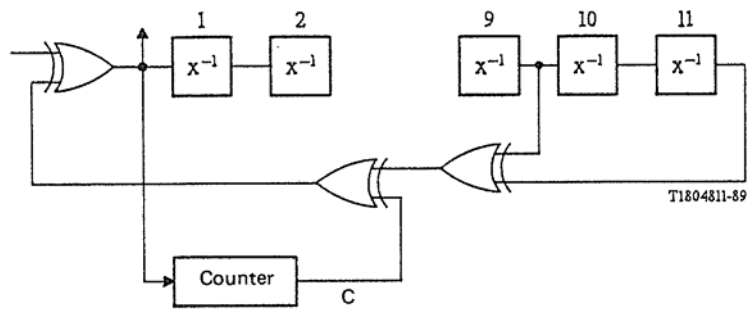

FIGURE III-4/G.961

Scrambling circuit

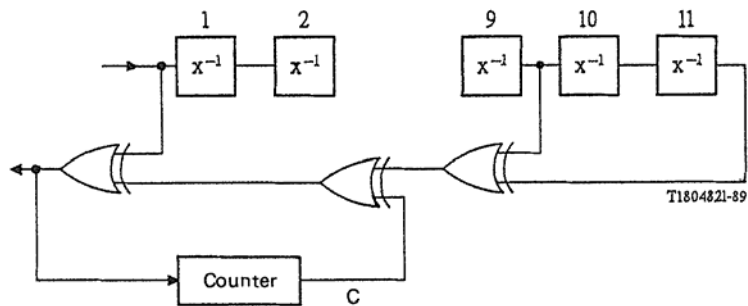

FIGURE III-5/G.961

Descrambling circuit

The counter C is incremented at each transmitted binary ONE and cleared at each transmitted binary ZERO. The counter sends a binary ZERO when 16 consecutive ONES have been transmitted and sets its threshold to 2 if a binary ONE appears again at its input. In this condition, the counter sends a binary ZERO every two consecutive binary ONES at its inputs. The threshold is reset to 16 at the first binary ZERO transmitted.

III.10 *Activation/deactivation*

The guidelines taken into account in the definition of activation/deactivation procedures can be summarized as follows:

- In the deactivated state, no signal is present on the line.
- During activation appropriate signals are sent to speed up the convergence of the equalizer, the bit and frame synchronization and the echo canceller convergence.

A master/slave relationship is assumed between LT and NT1, so that, even if NT1 starts to request an activation, it is always the LT (under the ET acknowledgment), that assumes the initiative of continuing the procedure and then the transmission.

The system will support the activation of both the transmission system and the interface at T reference point, the activation of the transmission system only, interface, the deactivation of both the transmission system and the interface at T reference point or of the interface at T reference point only.

Cold and warm activations are possible. Cold activation starts after the power off - power on transition or after some specific maintenance procedures. Cold start refers to NT1 and LT which do not have stored any information about the echo canceller coefficients or equalizers setting, so a long time for activation is expected. Warm activation apply when LT and NT1 contain full information about the echo canceller coefficients and the line equalizers setting, so a short activation time is expected.

Power down mode refers to a state with very low power consumption of both LT and NT1 and with the absence of any line signal, this state allows to statistically reduce the power feeding from the central office. Of course some parts of the system, in particular the receiving sections, are always active to detect the incoming activation requests.

III.10.1 *Signals used for activation*

III.10.1.1 *Signals used for start up (CL not available)*

During the activation/deactivation procedures the following specific signals (SIGS) are exchanged on the line between LT and NT:

Down stream (LT → NT1)

- INFO U0 (IU0): No signals on the line.
- INFO U12 (IU12): 20 kHz burst tone. This line signal is obtained by repeating 72 times the following pattern of 8 line symbols (+ + + + - - - -) every 8 ms. The burst tone is sent in half-duplex way.
- INFO U22 (IU22): 80 kHz burst tone. This line signal is obtained by repeating 291 times the following pattern of 2 line symbols (+ -) every 8 ms. The burst tone is sent in half-duplex way.
- INFO U4 (IU4): Full-duplex transmission. The line signal has the same frame structure of the useful signal but with B1, B2, D and CL bit channels at the binary value ZERO. The binary stream is scrambled with a pseudorandom sequence and encoded according to the AMI rule. The second bit of the frame is set to the binary value ZERO.
- INFO U6 (IU6): Full-duplex transmissison of operative data on the B and D channels; CL channel is used to convey layer 1 activation/deactivation, testing and maintenance information. The second bit of the frame is set to the binary value ONE.

Upstream (NT1 → LT)

- INFO U0 (IU0): No signals on the line.
- INFO U11 async.: 20 kHz burst tone. This line signal is obtained by repeating 72 times the following pattern of 8 line symbols (+ + + + - - - -) every 16 ms. The burst tone is sent in half-duplex way.
- INFO U11 sync.: 20 kHz burst tone. This line signal is obtained by repeating 72 times the following pattern of 8 line symbols (+ + + + - - - -) every 8 ms. The burst tone is sent in half-duplex way synchronized to the IU12 coming from LT.
- INFO U21 (IU21): 80 kHz burst tone. This line signal is obtained by repeating 291 times the following pattern of 2 line symbols (+ -) every 8 ms. The burst tone is sent in half-duplex way.
- INFO U3 (IU3): Full-duplex transmission. The line signal has the same frame structure of the useful signal but with B1, B2, D and CL bit channels at the binary value ZERO. The binary stream is scrambled with a pseudorandom sequence and encoded according to the AMI rule. The second bit of the frame is set to the binary value ONE.
- INFO U5 (IU5): Full-duplex transmission of operative data on the B and D channels; CL channel is used to convey layer 1 activation/deactivation, testing and maintenance information. The second bit of the frame is set to the binary value ZERO.

III.10.1.2 *Bits in the CL channel*

The I bits (see § III.6.1) of the CL channels are used to convey both activation/deactivation commands and testing and maintenance commands/reports, while P and O bits are employed for parity checking and error detecting and coded consequently. Only the activation/deactivation signals that are exchanged between LT and NT1 and conveyed through the CL channel are listed below.

I bits of CL Channel from LT to NT1

000010001 ACTIVATE REQUEST (AR)

Request to activate all the layer 1, both transmission system and interface at T reference point are activated

000001111 TRANSMISSION SYSTEM ACTIVATE REQUEST (UAR)

Request to activate the transmission system only. As in case of an AR command, the activation procedure is automatically performed. In the case in which the interface at T reference point is active, it will be deactivated.

000010011 ACTIVATE REQUEST with LOOPBACK 2 (AR2)

Request to activate with loopback 2 in NT1.

000000001 DEACTIVATE REQUEST (DR)

Request to deactivate the transmission system. The LT and NT1 automatically perform the deactivation procedure.

I bits of CL Channel from NT1 to LT

000001001 RESYNCHRONIZATION (RSY)

The RSY indication is input by the T interface when the synchronization on the interface at T reference point has been lost and not valid data are available.

000011001 ACTIVATE INDICATION (AI)

The activation procedure at the interface at T reference point has been successfully completed up to the terminal equipments when the AI is active.

000011101 ACTIVATE INDICATION with LOOPBACK 2 (AIL)

The connection through loopback 2 at the T-interface has been established. After an ARL command, the AIL indicate signal acknowledges the the receiving of an AI.

000001111 TRANSMISSION SYSTEM ACTIVATION INDICATION (UAI)

The transmission system is activated in NT1 and this information is transferred to LT/ET. The interface at T reference point is not activated.

III.10.2 *Definition of internal timers*

During the activation/deactivation procedures the following timers shall be used:

- *Timer A:* This timer is located in NT1. It has two different meanings: during the activation procedure its value is 8 seconds and is an upper limit for the activation time. Whenever, the activation is reached its value is 500 ms as a guard time to prevent unwanted deactivations due to interruption of signal or loss of line frame coming from LT.
- *Timer 2:* This timer is located in NT1. Its value is fixed in 50 ms and its purpose is to prevent from unwanted reactivations from a TE.

III.10.3 *Description of the activation procedure*

III.10.3.1 *Description of the activation procedure from LT*

Figure III-6/G.961 based on arrow sequence summarizes the activation procedure originated from ET. The activation procedure is started from an Activation request (FE1) coming from the ET. LT starts the procedure with an FE2 to ET and transmitting (IU12) on the line. At the reception of (IU11) from NT1, LT transmits (IU22) towards NT1. (IU22) is used by the NT1 for line equalizer setting (only for cold starts), fast timing recovery and AMI decision threshold setting. Once that NT1 finished its training procedure, it transmits towards LT (IU21). This SIG is used by LT for line equalizer setting (only cold starts), timing recovery and AMI decision thresholds setting. Then LT transmits

(IU4) which is used by the NT1 for echo canceller updating (short training period for warm starts, longer for cold starts). At the end of this training period, NT1 sends (IU3) which is used by LT for the same purposes just explained for the NT1. Whenever all the training periods are over, LT sends (IU6) (operative B and D channels) in which the I bits of the CL channel carry FE1 command. NT1 answers with (IU5) (operative B and D channels) with FE3 code in the CL I bits if the interface at T reference point is not active and then (IU5) with FE4 when the interface at T reference point is active.

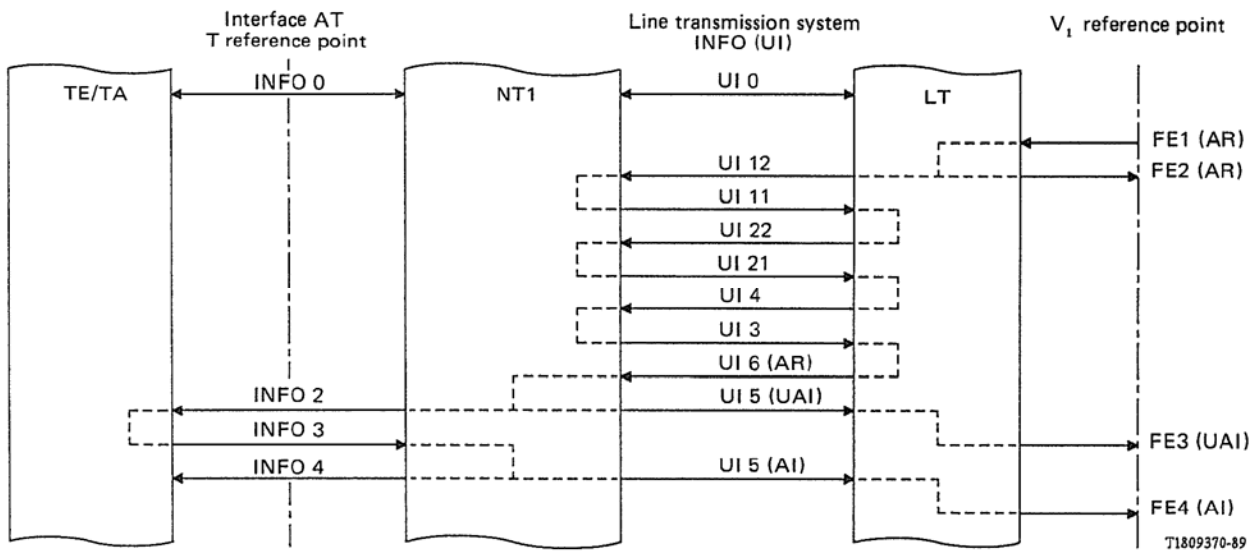

FIGURE III-6/G.961

Layer 1 activation from the network side

III.10.3.2 Description of the activation procedure from NT1

Figure III-7/G.961 based on arrow sequence summarizes the activation procedure originated from the user side. The activation procedure is started from an activation request INFO1 coming from the interface at T reference point. NT1 starts the procedure transmitting IU11 asyn towards LT. LT passes this information to the ET with FE2 and waits for the ET FE1 to continue the activation procedure. If ET gives its acknowledgment with FE1, then the activation procedure resumes and is equal to that shown in § III.10.3.1.

III.10.3.3 Description of the deactivation procedure

The deactivation of the layer 1 is physically performed only under complete control of the LT/ET. The deactivation is started from ET with FE3 to LT. LT transmit (IU6) with the command DR in the I bits of the CL channel. NT1 send INFO 0 to the interface at T reference point and (IU0) back to LT. Figure III-8/G.961 based on arrow sequence summarizes the deactivation procedure.

III.10.4 NT1 state transition table

The detailed behaviour of the activation/deactivation procedure in NT1 is described in the Table III-1/G.961 as a function of INFOS, SIGs and internal timers.

Loopback 2 shall be originated only from a deactivated state, and no transitions from loopback 2 to active state shall be possible.

III.10.5 LT state transition table

The detailed behaviour of the activation/deactivation procedure in LT is described in the Table III-2/G.961 as a function of INFOS, SIGs and internal timers.

Loopback 1 shall be originated only from a deactivated state, and no transitions from loopback 1 to active state shall be possible. Loopback 1 shall be transparent or not. It is possible that after loopback 1 a long activation (cold start) will be required, as the system could lose all the information about the line equalizer, echo canceller coefficients and so on.

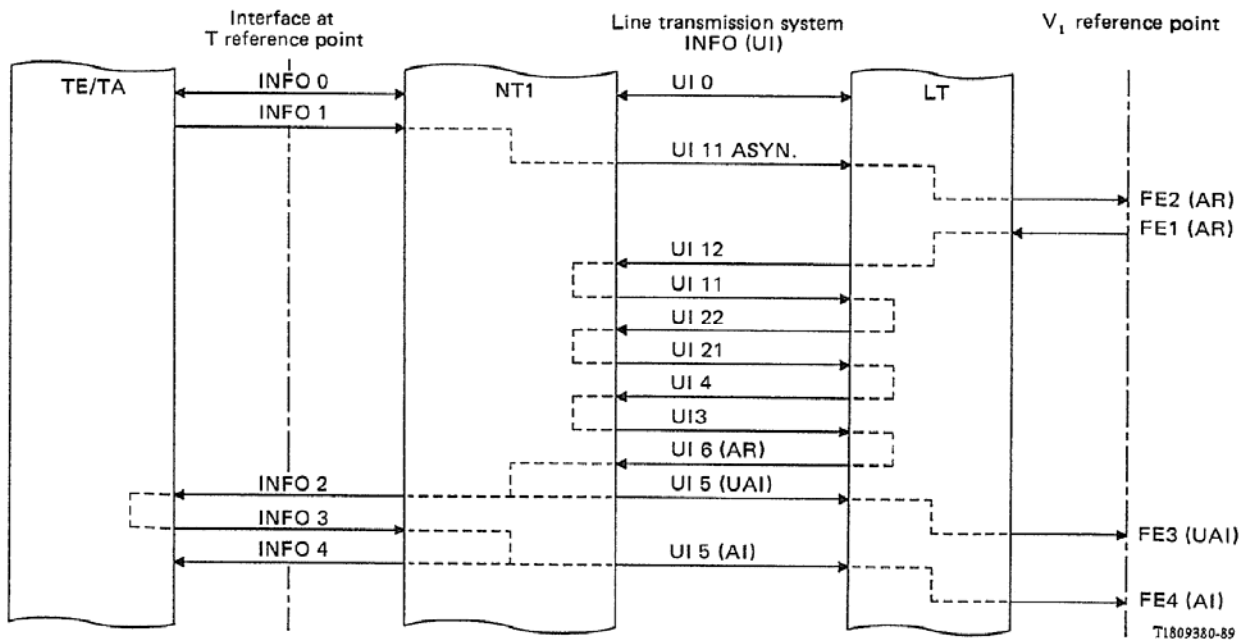

FIGURE III-7/G.961

Layer 1 activation from the user side

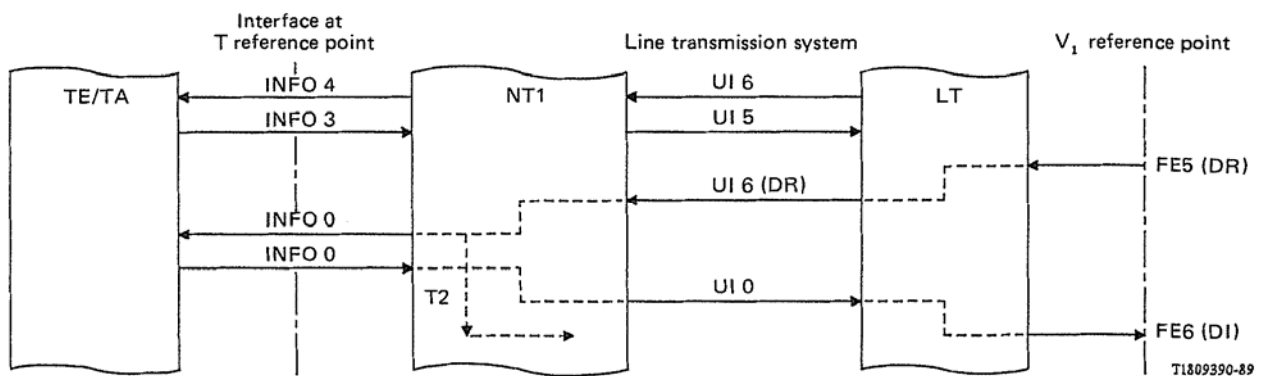

FIGURE III-8/G.961

Layer 1 deactivation

TABLE III-1/G.961
State transition table NT1 (NT-states matrix)

State		NT1	NT2	NT3	NT4	NT5	NT6	NT7	NT8	NT9	NT10	NT11	NT12	NT13	NT14	NT15	
Name		Deactivation	Pending activation step 1	Pending activation step 2	Pending activation step 3	Pending activation step 4	Line only active	Pending activation T int.	T interf. + line active	Lost of frame at U in NT6	Lost of frame at U in NT8, 9	Pending deactivat. exp. TA	Pending deactivat. IU6 (DR)	U inter. active loop 2	Loop 2 active	Loss of fr. at U loop 2	
Signals Tx	Line INFO	IU0	IU11 asy	IU11	IU21	IU3	IU5 + UAI on CL	IU5 + X on CL	IU5 + AI on CL	IU0	IU0	IU0	IU5 + X on CL	IU5 + UAI or RSY	IU5 + AI on CL	IU0	
	S/T	INFO 0	INFO 0	INFO 0	INFO 0	INFO 0	INFO 0	INFO 2	INFO 4	INFO 0	INFO X	INFO 0	INFO 0	INFO 2	INFO 4	INFO X	
I/S	INFO 0	-	-	-	-	-	-	-	NT7	-	-	NT1	NT1	/	NT13	-	
	INFO 1	NT2	-	-	-	-	---	-	NT7	-	-	-	-				
	INFO 2													NT14	-	-	
	INFO 3	/	/	/	/	/	/	NT8	-	/	-	-	-	/	-	-	
	Loss of frame align. at T int.	/	/	/	/	/	/	/	NT7	/	/	-	-	/	NT13	/	
	Expiry T2	/	/	/	/	/	/	/	/	/	/	/	NT1	NT1	/	/	/
	Expiry TA	/	ST.T2 NT11	ST.T2 NT11	ST.T2 NT11	ST.T2 NT11	/	/	/	NT1	ST.T2 NT11	/	/	/	/	/	ST.T2 NT11
	IU0	-	-	ST.TA	ST.TA	ST.TA	-	-	-	-	-	-	-	-	-	-	-
	IU12	NT3	NT3	-	ST.TA	ST.TA	/	/	/	/	/	/	-	-	/	/	/
	IU22	/	/	Stop TA NT4	-	ST.TA	/	/	/	/	/	/	-	-	/	/	/
LINE	IU4	/	/	ST.TA	Stop TA NT5	-	/	/	/	/	/	-	-	/	/	/	
	IU6 + AR on CL	/	/	/	/	Stop TA NT7	NT7	-	-	/	/	-	-	/	/	/	
	IU6 + UAR on CL	/	/	/	/	Stop TA NT6	-	/	NT6	/	/	-	-	/	/	/	
	IU6 + AR2 on CL	/	/	/	/	Stop TA NT13	/	/	/	/	/	-	-	-	-	/	
	IU6 + DR on CL	/	/	/	/	/	NT1	ST.T2 NT12	ST.T2 NT12	/	/	-	-	ST.T2 NT12	ST.T2 NT12	/	
	Loss of frame align. at U int.	/	/	/	/	/	ST.TA NT9	ST.TA NT10	ST.TA NT10	-	-	/	/	ST.TA NT15	ST.TA NT15	-	
	Recovery from loss of frame align. at U int.	/	/	/	/	/	/	/	/	Stop TA NT6	Stop TA NT7 ou NT8	/	/	/	/	Stop TA NT13 or NT14	

Note – For symbols and abbreviations, see Table III-2/G.961.

TABLE III-2/G.961
State transition table LT (LT-states matrix)

State		LT1	LT2	LT3	LT4	LT5	LT6	LT7	LT8	LT9	LT10	LT11	LT12	LT13	
Name		Deactivation	Wait activation	Pending activat. step 1	Pending activat. step 2	Pending activat. step 3	Pending activat. step 4	Line only active	T int. or loop 2 active	Loss of frame at U in LT8	Loss of frame at U in LT7	Remote error indication	Loss of frame at U in LT11	Pending deactivation	
New event Rx	Signals Tx	IU0	IU0	IU12	IU22	IU4	IU6 + FE on CL	IU6 + FE on CL	IU6 + FE on CL	IU6 + FE on CL	IU6 + FE on CL	IU6 + FE on CL	IU6 + FE on CL	IU6 + FE on CL	
	Line INFO														
	V ₁	FE 6 (DI)	FE 2 (AR)	FE 2 (AR)	FE 2 (AR)	FE 2 (AR)	FE 2 (AR)	FE 3 (UAI)	FE 4 (AI)	FE 7 (RSY)	FE 7 (RSY)	FE 7 (RSY)	FE 7 (RSY)	FE 7 (RSY)	
LINE	FE 1 (AR)	LT3	LT3	-	-	-	-	-	-	-	-	-	-	-	
	FE 11 (UAR)	LT3	/	-	-	-	-	-	-	-	-	-	-	-	
	FE 9 (ARL)	LT4	/	/	-	-	-	-	-	-	-	-	-	-	
	FE 8 (AR2)	LT3	/	-	-	-	-	-	-	-	-	-	-	-	
	FE 10 (AR4)	LT3	/	-	-	-	-	-	-	-	-	-	-	-	
	FE 5 (DR)	-	-	LT1	LT1	LT1	LT1	LT13	LT13	LT1	LT1	LT13	LT1	-	
	IU11 asyn.	LT2	-	-	-	-	-	-	-	-	-	-	-	-	
	IU11	/	LT1	LT4	-	-	-	-	-	-	-	-	-	-	
	IU21	/	LT1	-	LT5	-	-	-	-	-	-	-	-	-	
	IU3	/	LT1	-	-	LT6	-	-	-	-	-	-	-	-	
	IU5 + UAI on CL	/	LT1	-	-	-	LT7	-	LT7	-	-	LT7	-	-	
	IU5 + AI on CL	/	LT1	-	-	-	LT8	LT8	-	-	-	LT8	-	-	
	IU5 + AR on CL	/	/	/	/	/	/	/	LT6	/	/	/	/	/	
	IU0	-	LT1	-	-	-	-	-	-	-	-	LT8	-	LT1	
	IU5 + RSY on CL	/	LT1	-	-	-	-	-	LT11	LT11	-	-	-	-	
	Loss of frame align. at U int.	/	/	/	/	/	/	/	LT10	LT9	-	-	LT12	-	LT1
	Recovery from loss of frame at U int.	/	/	/	/	/	/	/	/	/	LT8	LT7	/	LT11	/

Symbols, abbreviations and Notes for Tables III-1/G.961 and III-2/G.961

/	Impossible event
–	No change state
	Impossible event by the definition of the layer 1 service
INFO IU5 + X	Line signal with X-message on CL channel
INFO IU6 + X	Line signal with X-message on CL channel
ST.T2	Start timer T2
ST.TA	Start timer TA
INFO U6 + FE	Line signal with a message on CL channel related with FE and V1 interface coming from ET1.

Note – NT1 transmits on the CL channel AR instead of UAI.

III.10.6 *Activation times*

The activation time from a warm start shall be less than 300 ms.

The activation time from a cold start shall be less than 4 seconds.

III.11 *Jitter*

Jitter tolerances are intended to ensure that the limits of Recommendation I.430 are supported by the jitter limits of the transmission system on local lines. The jitter limits given below must be satisfied regardless of the length of the line and the inclusion of one regenerator, provided that they are covered by the transmission media characteristics (see § 3). The limits must be met regardless of the transmitted bit patterns in the B, D and CL channel.

III.11.1 *NT input signal jitter tolerance*

The NT1 shall meet the performances objectives with wander/jitter at the maximum magnitudes indicated in Figure III-9/G/961 for single jitter frequencies in the range of 1 Hz to 40 kHz, superimposed on the test signal source. The NT1 shall also meet the performance objectives with wander per day of up to 3 UI peak to peak where the maximum rate of change of phase is 0.6 UI/hour.

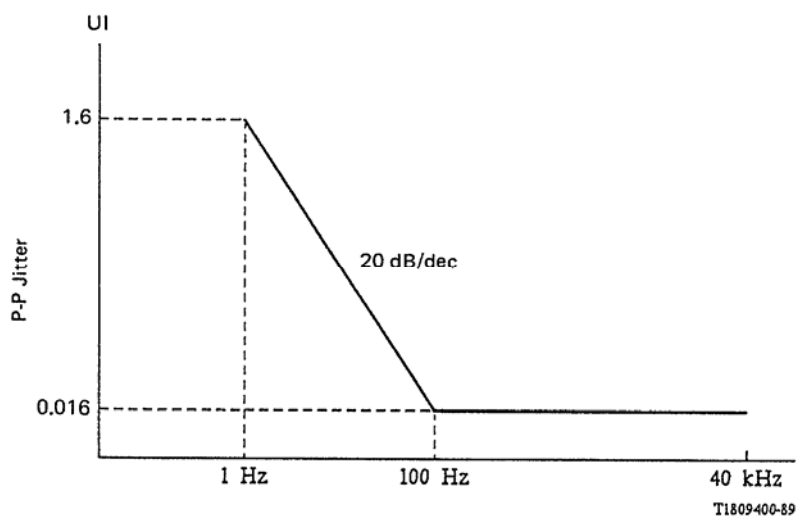

FIGURE III-9/G.961

Minimum tolerable jitter on NT1 input signal

III.12.3 *Signal power*

The average signal power shall be between 8 dBm and 9 dBm.

III.12.4 *Power spectrum*

The upper bound of the power spectral density shall be within the template of Figure III-11/G.961.

III.12.5 *Transmitter signal nonlinearity*

The transmitter signal nonlinearity shall be less than 1%.

III.13 *Transmitter/receiver termination*

III.13.1 *Impedance*

The nominal input/output impedance looking towards to the NT1 or LT respectively shall be 130 ohms.

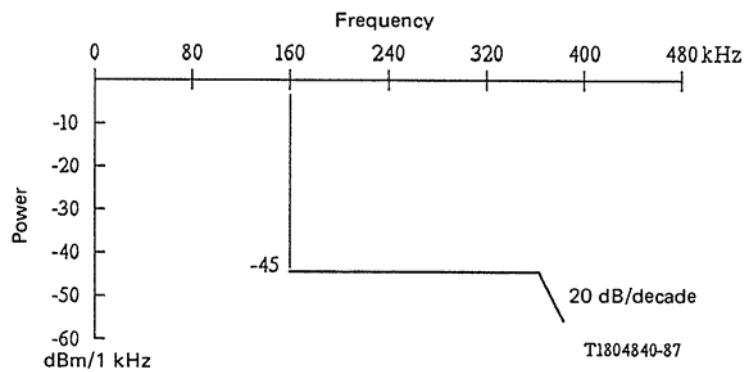

FIGURE III-11/G.961

Template of the transmitted power spectral density

III.13.2 *Return loss*

The return loss of the impedance shall be greater than 11 dB in the frequency range 5 to 60 kHz and greater than 16 dB in the frequency range 60 to 100 kHz.

III.13.3 *Longitudinal conversion loss*

The minimum longitudinal conversion loss shall be as follows:

- up to 80 kHz 45 dB;
- above 80 kHz 40 dB.

APPENDIX IV

(to Recommendation G.961)

Electrical characteristics of an AMI transmission system using a TCM method

IV.1 *Line code*

For both directions of the transmission, the line code is AMI. The coding scheme will be performed in such a way that a binary ZERO is represented by no line signal, while a binary ONE is represented by a positive or negative pulse alternately.

IV.2 *Symbol rate*

The symbol rate is determined by the line code, rate of the information stream and the frame structure. The bit symbol rate is 320 kbauds.

IV.2.1 *Clock requirements*

IV.2.1.1 *NT1 free running clock accuracy*

The accuracy of the free running clock in the NT1 shall be ± 50 ppm.

IV.2.1.2 *NT1 clock tolerance*

The NT1 shall accept a clock accuracy from the LT of ± 10 ppm.

IV.2.1.3 *LT clock tolerance*

The LT shall accept a clock accuracy from the ET of ± 10 ppm.

IV.3 *Frame structure*

The frame structure contains a frame word, N times (2B + D) and a CL channel.

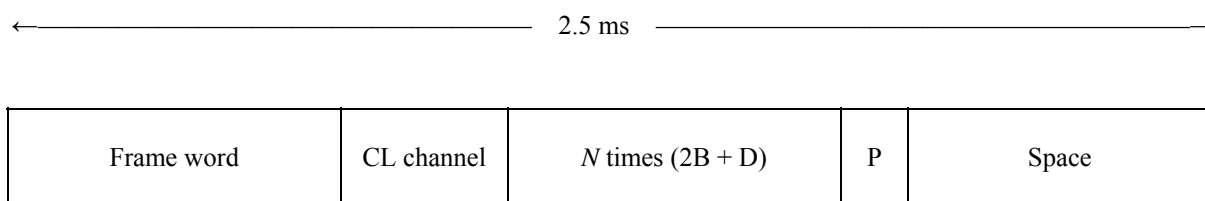

P Parity bit: The P bit is used to get an even number of binary ONEs in a frame; so it is set to binary ONE or binary ZERO when the number of binary ONEs in a frame is odd or even respectively

IV.3.1 *Frame length*

The number *N* of (2B + D) slots in one frame is twenty.

IV.3.2 *Bit allocation in direction LT-NT1*

In Figure IV-1/G.961, the bit allocation is given.

IV.3.3 *Bit allocation in direction NT1-LT*

In Figure IV-2/G.961, the bit allocation is given.

Bit positions	1~8	9	10	11~13	14~16	XX (Note)	YY (Note)	ZZ (Note)	VV (Note)	377	378~800
Functions	Frame word	Control bit	Multiframe bit	Control bits	CRC bits	B ₁ channel	D channel	B ₂ channel	D channel	Parity bit	Space (No line signal)
		CL channel									

Note – XX = (17 + 18n) until (24 + 18n); where n = 0~19.

YY = 25 + 18n ; where n = 0~19.

ZZ = (26 + 18n) until (33 + 18n); where n = 0~19.

VV = 34 + 18n ; where n = 0~19.

FIGURE IV-1/G.961

Bit allocation in direction LT-NT1

Bit positions	1~8	9	10	11~13	14~16	XX (Note)	YY (Note)	ZZ (Note)	VV (Note)	377	378~800
Functions	Frame word	Information bit	Multiframe bit	Information bits	CRC bits	B ₁ channel	D channel	B ₂ channel	D channel	Parity bit	Space (No line signal)
		CL channel									

Note - $XX = (17 + 18n)$ until $(24 + 18n)$; where $n = 0 \sim 19$.

$YY = 25 + 18n$; where $n = 0 \sim 19$.

$ZZ = (26 + 18n)$ until $(33 + 18n)$; where $n = 0 \sim 19$.

$VV = 34 + 18n$; where $n = 0 \sim 19$.

FIGURE IV-2/G.961

Bit allocation in direction NT1-LT

IV.4 *Frame word*

The frame word is used to allocate bit position to the $2B + D + CL$ channels. It may, however, also be used for other functions.

IV.4.1 *Frame word in direction LT-NT1*

The code for the frame word will be “100000M0”; M is “1”/“0” alternating bit in every frame.

IV.4.2 *Frame word in direction NT1-LT*

The code for the frame word will be “1000000M”; M is “1”/“0” alternating bit in every frame.

IV.5 *Frame alignment procedure*

The frame alignment procedure is defined as follows.

a) *Frame alignment state*

The transmission system is considered to be frame alignment state if the frame word has been identified in the same position for three consecutive frames.

b) *Loss of frame alignment state*

The transmission system is considered to be loss of frame alignment state if the frame word has not been identified in the expected frame position for six frames before identifying the frame word in the frame position for twelve frames.

IV.6 *Multiframe*

To enable bit allocation of the CL channel in more frames next to each other, a multiframe structure may be used. The start of the multiframe is determined by the frame word. The total number of frames in a multiframe is four.

IV.6.1 *Multiframe word in direction LT-NT1*

The multiframe is identified by the multiframe bit allocated in the CL channel. The code for the multiframe word, which is defined by the multiframe bits in four consecutive frames under the frame alignment state, is “1000”.

IV.6.2 *Multiframe word in direction NT1-LT*

The same as IV.6.1.

IV.7 *Frame offset between LT-NT1 and NT1-LT frames*

The NT1 shall synchronize its frame on the frame received in the direction LT to NT1 and will transmit its frame with an offset. Relative frame position at the NT1 input/output is as follows. The first bit of each frame transmitted from the NT1 toward the LT shall be delayed by 383 up to 384 bit periods with respect to the first bit of the frame received from the LT.

IV.8 *CL channel*

IV.8.1 *Bit rate*

The bit rate for the CL channel is 3.2 kbit/s.

IV.8.2 *Structure*

- a) Thirty two bits (3.2 kbit/s) are allocated in a multiframe for the use of CL channel.
- b) Four bits (0.4 kbit/s) are allocated to multiframe bits.
- c) Sixteen bits (1.6 kbit/s) are allocated to maintenance and operational control functions in direction LT to NT1, and to maintenance and operational information functions in direction NT1 to LT.
- d) Twelve bits (1.2 kbit/s) are allocated to a cyclic redundancy check (CRC) function.

IV.8.3 *Protocols and procedures*

Protocols and procedures of maintenance/operational control/information are as follows.

- a) Transfer modes are bit-oriented.
- b) Sending modes are continuous.
- c) Identification is confirmed by identical bits receiving for three consecutive multiframes under the frame alignment state.
- d) Duration of control invocations is as long as sending control is identified.
- e) Duration of information invocations is as long as causing event is identified.

IV.9 *Scrambling*

Scrambling will be applied on 2B + D channels and the scrambling algorithm shall be as follows.

- In direction LT-NT1: $x^9 \oplus x^5 \oplus 1$
- In direction NT1-LT: $x^9 \oplus x^5 \oplus 1$

IV.10 *Activation/deactivation*

Activation/deactivation is defined in Recommendation G.960, § 5. Applications provided by the transmission system are described as follows.

IV.10.1 *Signals used for activation*

Definition of the signals used for activation/deactivation (SIGs) are listed below. Signals used for start-up (bits in the CL channel are not available) and bits in the CL channel (in already established frames) are defined.

- a) Signals used for start-up (CL not available):
 - SIG 0 (NT1 to LT and LT to NT1): No line signal.
 - SIG 1 (LT to NT1): A signal which deactivates the line and the interface at T reference point.
 - SIG 2 (NT1 to LT): An awake signal to invoke the LT layer 1 that it has to enter the power up state and provide for the activation of the line and the interface at T reference point. It is invoked by receiving the signal INFO 1 across the T reference point in case of the activation from the user side. This signal is also used as awake acknowledgement on receiving of the signal SIG 3 in case of the activation from the network side.
 - SIG 3 (LT to NT1): An awake signal to invoke the NT1 layer 1 that it has to enter the power up state and prepare for synchronization on an incoming signal from the LT. This signal is also used as awake acknowledgement on receiving of the signal SIG 2 in case of the activation from the user side.
 - SIG 4 (LT to NT1): A signal which contains framing information and allows the synchronization of the receiver in the NT1.
 - SIG 5 (NT1 to LT): A signal which contains framing information and allows the synchronization of the receiver in the LT. It informs the LT that the NT1 has synchronized on the signal SIG 4.
- b) Bits in CL channel in already established frame:
 - SIG 6 (LT to NT1): A signal which requires the NT1 to establish the full layer 1 information transfer capability available between the NT1 and LT, and requires the NT1 to activate the T interface by sending the signal INFO 2 across the T reference point.
 - SIG 7 (LT to NT1): A signal which requires the NT1 to establish the full layer 1 information transfer capability available between TE and the ET by sending the signal INFO 4 across the T reference point.
 - SIG 8 (NT1 to LT): A signal which indicates that the interface at T reference point is activated, and requires the LT to provide the full layer 1 information transfer capability available between TE and the ET. It is invoked by receiving of the signal INFO 3 across the T reference point.
 - SIG 9 (LT to NT1): A signal which requires the NT1 to establish the full layer 1 information transfer capability available between the NT1 and LT, and requires the NT1 to activate the loopback 2.

- SIG 10 (NT1 to LT): A signal which indicates that the loopback 2 is activated in the NT1, and requires the LT to provide the full layer 1 information transfer capability available between the NT1 and ET.
- SIG 11 (LT to NT1 and NT1 to LT): A synchronization signal which contains framing information and 2B + D + CL channels.
- SIG 12 (NT1 to LT): A signal which indicates that the receiver on the T interface side of the NT1 has entered lost framing state.
- SIG 13 (LT to NT1): A signal which indicates that the receiver on the line side of the LT has entered lost framing state. This signal also contains a function as the signal SIG 4.
- SIG 14 (NT1 to LT): A synchronization signal which contains framing information and 2B + D + CL channels; bits in the 2B + D channels are set to be idle.

Note – Definition of the function element (FEs) across the V reference point is described in Recommendation G.960, § 5.4. FEs used for activation/deactivation are relisted in Table IV-1/G.961.

TABLE IV-1/G.961

The repertoire of function elements associated with the activation/desactivation procedures

FEs	Direction	Repertoire
FE 1	ET to LT	Activation request for the interface at T reference point
FE 5	ET to LT	Deactivation request for the line and the interface at T reference point
FE 9	ET to LT	Activation request for loopback 1
FE 8	ET to LT	Activation request for loopback 2
FE 4	LT to ET	The T interface is activated or a loopback is provided respectively
FE 3	LT to ET	The line is activated
FE 6	LT to ET	The line and the interface at T reference point are deactivated
FE 7	LT to ET	Error indication
FE 2	LT to ET	Request to start timer T1 within the ET layer 1

IV.10.2 *Definition of internal timers*

Timer T2 (see Recommendation I.430, § 6) resides within the LT layer 1.

IV.10.3 *Description of the activation procedure*

- a) Activation from the network side: See Figure IV-3/G.961.
- b) Activation from the user side: See Figure IV-4/G.961.
- c) Deactivation from the network side: See Figure IV-5/G.961.
- d) Activation of loopback 2: See Figure IV-6/G.961.

Note 1 – Activating the line system only, where the full information transfer capability is available while the interface at T reference point remains deactivated, is not provided.

Note 2 – A non-transparent loopback 1 is provided where no line signal is transmitted at the LT 2-wire point.

Note 3 – A non-transparent loopback 2 is provided where INFO 0 is sent from the NT1 at the interface at T reference point.

Note 4 – A repeater is not applicable.

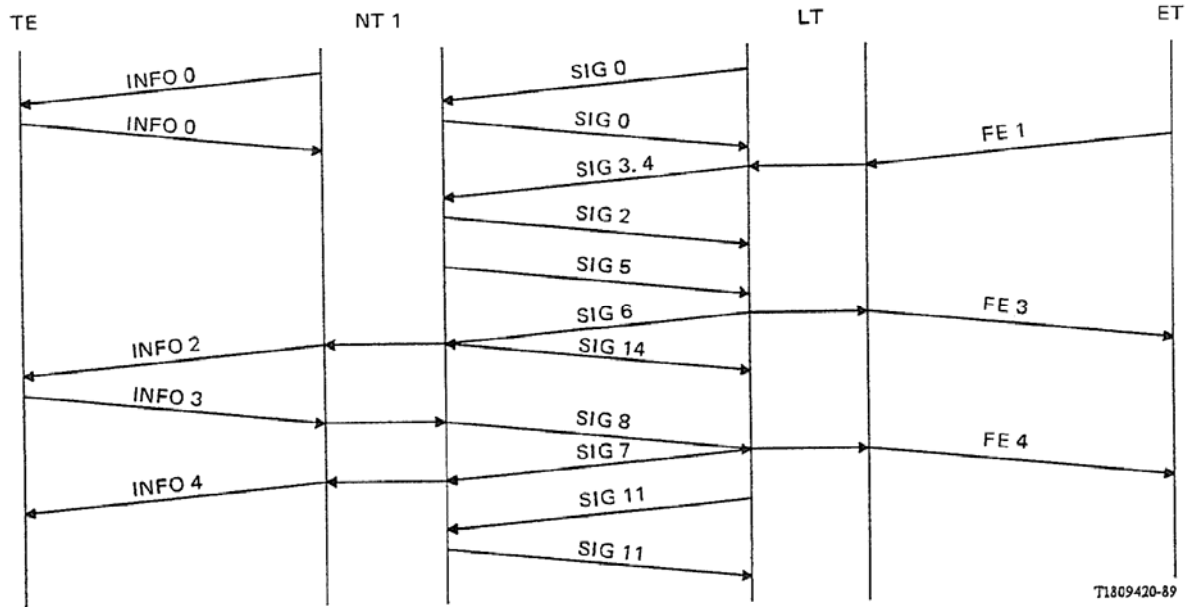

FIGURE IV-3/G.961

Activation from the network side

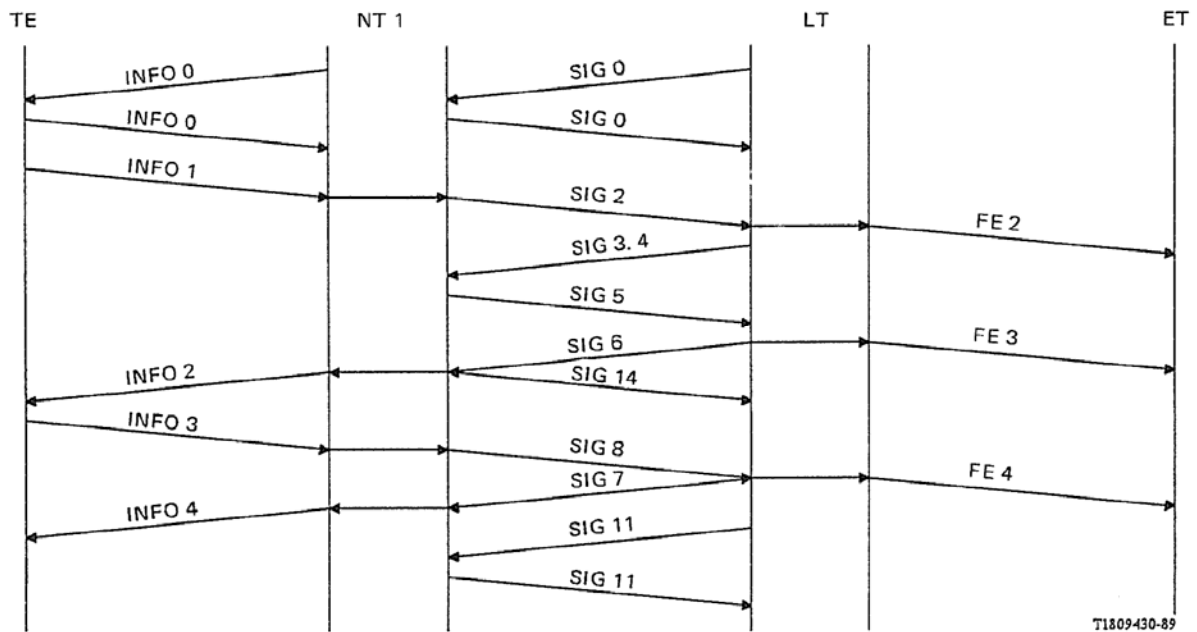

FIGURE IV-4/G.961

Activation from the user side

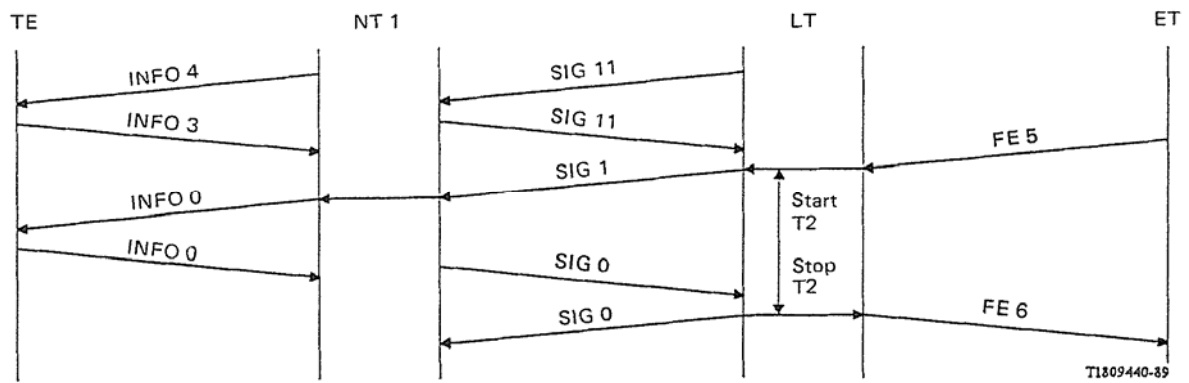

FIGURE IV-5/G.961

Deactivation from the network side

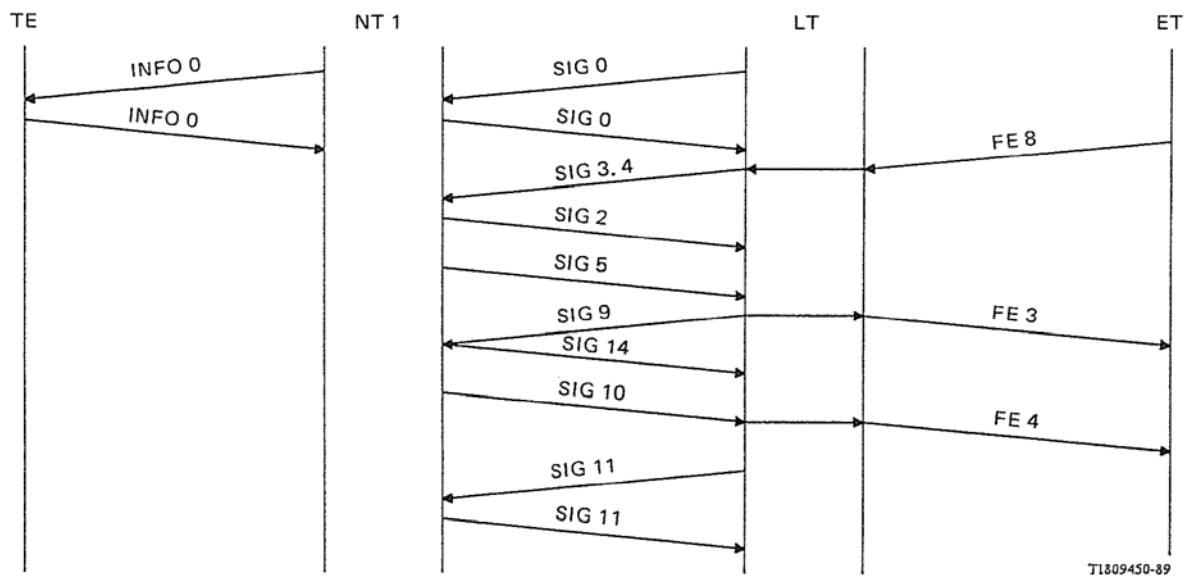

FIGURE IV-6/G.961

Activation of loopback 2

IV.10.4 *State transition table NT1*

State transition table NT1 as a function of INFOs and SIGs is defined in Table IV-2/G.961.

IV.10.5 *State transition table LT*

State transition table LT as a function of FEs, SIGs and the internal timer T2 is defined in Table IV-3/G.961.

TABLE IV-2/G.961

State transition table NT1

Event	State name	Deactive	Pending power activation	Pending activation of line at NT1 side	Pending activation of line at LT side	Line active	T- interface pre-active	T- interface active	Lost framing of T- interface	Ligne active	Loopback 2 active
	State code	NT 1.0	NT 1.1	NT 1.2	NT 1.3	NT 1.4	NT 1.5	NT 1.6	NT 1.7	NT 2.1	NT 2.2
	Tx	INFO 0	INFO 0	INFO 0	INFO 0	INFO 2	INFO 2	INFO 4	INFO 2	INFO 0	INFO 0
		SIG 0	SIG 2	SIG 2	SIG 5	SIG 14	SIG 8	SIG 11	SIG 12	SIG 14	SIG 10 SIG 11
SIG 1	/	NT 1.0	NT 1.0	NT 1.0	NT 1.0	NT 1.0	NT 1.0	NT 1.0	NT 1.0	NT 1.0	NT 1.0
SIG 3	NT 1.2	NT 1.2	-	-	/	/	/	/	/	/	/
Line of NT1 side active	/	/	NT 1.3	-	-	-	-	-	-	-	-
SIG 6	/	/	/	NT 1.4	-	-	-	-	-	-	-
SIG 7	/	/	/	/	/	NT 1.6	-	-	-	/	/
SIG 9	/	/	/	NT 2.1	/	/	/	/	/	-	-
SIG 13	/	/	/	-	NT 1.3	NT 1.3	NT 1.3	NT 1.3	NT 1.3	NT 1.3	NT 1.3
Lost framing of T interface	/	/	/	/	/	NT 1.7	NT 1.7	NT 1.7	-	/	/
Lost framing of line at NT1 side	/	/	/	NT 1.2	NT 1.2	NT 1.2	NT 1.2	NT 1.2	NT 1.2	NT 1.2	NT 1.2
Receiving INFO 1	NT 1.1	-	-	-	-	/	/	/	/	-	-
Receiving INFO 3	/	/	/	/	/	NT 1.5	-	-	NT 1.5	/	/
Loopback 2 established	/	/	/	/	/	/	/	/	/	NT 2.2	-

/ Impossible event

- No state change

TABLE IV-3/G.961

State transition table LT

Event	State name	Deactive	Pending activation of line	Line active	T- interface active	Pending deactivation	Lost framing of line	Pending activation of line	Line active	Loopback 2 active
	State code Tx	LT 1.0	LT 1.1	LT 1.2	LT 1.3	LT 1.4	LT 1.5	LT 2.1	LT 2.2	LT 2.3
		SIG 0	SIG 3 SIG 4	SIG 6	SIG 7 SIG 11	SIG 1	SIG 13	SIG 3 SIG 4	SIG 9	SIG 11
SIG 2	FE 2 LT 1.1	-	-	/	/	-	-	/	/	
Line fully active	/	FE 3 LT 1.2	-	-	-	FE 3 LT 1.2	FE 3 LT 2.2	-	-	
SIG 8	/	/	FE 4 LT 1.3	-	-	/	/	/	/	
SIG 10	/	/	/	/	/	/	/	FE 4 LT 2.3	-	
Lost framing of line	/	/	FE 7 LT 1.5	FE 7 LT 1.5	-	-	/	FE 7 LT 2.1	FE 7 LT 2.1	
SIG 12	/	/	/	FE 7 LT 1.2	-	/	/	/	/	
Expiry of timer T2	/	/	/	/	LT 1.0	/	/	/	/	
FE 1	LT 1.1	/	/	/	/	/	/	/	/	
FE 5	/	ST.T2 LT 1.4	ST.T2 LT 1.4	ST.T2 LT 1.4	/	ST.T2 LT 1.4	ST.T2 LT 1.4	ST.T2 LT 1.4	ST.T2 LT 1.4	
FE 8	2.1	/	/	/	/	/	/	/	/	

/ Impossible event

- No state change

IV.10.6 *Activation times*

See Recommendation G.960, §§ 5.5.1 and 5.5.2.

IV.11 *Jitter*

Jitter tolerance is intended to ensure that the limits of Recommendation I.430 are supported by the jitter limits of the transmission system on local lines. The jitter limits given below must be satisfied regardless of the length of the local line and the inclusion of one regenerator, provided that they are covered by the transmission media characteristics (see § 3). The limits must be met regardless of bit patterns in the B, D and CL channels.

IV.11.1 *NT1 input signal jitter tolerance*

The NT1 shall meet the performance objective with wander/jitter at the maximum magnitudes indicated in Figure IV-7/G.961, for single jitter frequencies in the range of 3 Hz to 80 kHz, superimposed on the test signal source. The NT1 shall also meet the performance objectives with wander per day of up to 0.1 UI peak-to-peak where the maximum rate of change of phase is 1.0 UI/hour.

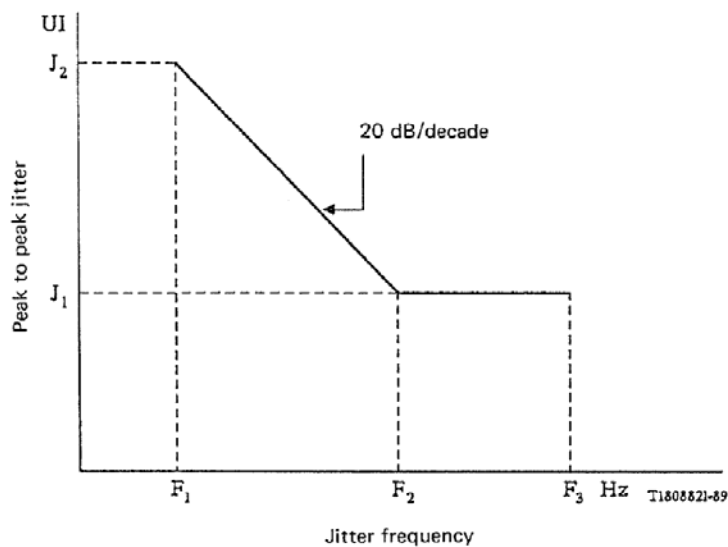

$$1 \text{ IU} = \frac{1}{320 \text{ kHz}} = 3.125 \text{ } \mu\text{s}$$

F ₁	F ₂	F ₃	J ₁	J ₂
3 Hz	30 Hz	80 kHz	0.1 UI	1.0 UI

FIGURE IV-7/G.961

Minimum tolerable jitter on NT1 input signal

IV.11.2 *NT1 output jitter limitations*

With the wander/jitter as specified in IV.11.1 superimposed on the NT1 input signal, the jitter on the transmitted signal on the NT1 toward the network shall conform to following:

- a) The jitter shall be equal to or less than 0.1 UI peak-to-peak and less than 0.25 UI rms when measured with a high-pass filter having a 20 dB/decade roll-off below 90 Hz.

- b) The jitter in the phase of the output signal relative to the phase of the input signal (from the network) shall not exceed 0.12 UI peak-to-peak or 0.025 UI rms when measured with a band-pass filter having a 20 dB/decade roll-off above 90 Hz and a 20 dB/decade roll-off below 0.3 Hz. This applies with superimposed jitter in the phase of the input signal as specified in § IV.11.1 for single frequency up to F_2 Hz.

IV.11.3 Test conditions for jitter measurements

Due to bidirectional transmission on the 2-wire and due to severe intersymbol interference no well defined signal transitions are available at the NT1 2-wire point.

Note – Two possible solutions are proposed:

- A test point in the NT1 is provided to measure jitter an undisturbed signal.
- A standard LT transceiver including an artificial local line is defined as a test instrument.

IV.12 Transmitter output characteristics of NT1 and LT

The following specification apply with a load impedance of 110 ohms.

IV.12.1 Pulse amplitude

The zero to peak nominal amplitude of the largest pulse shall be 6 V and the tolerance shall be $\pm 10\%$.

IV.12.2 Pulse shape

The pulse shape shall meet the pulse mask of Figure IV-8/G.961.

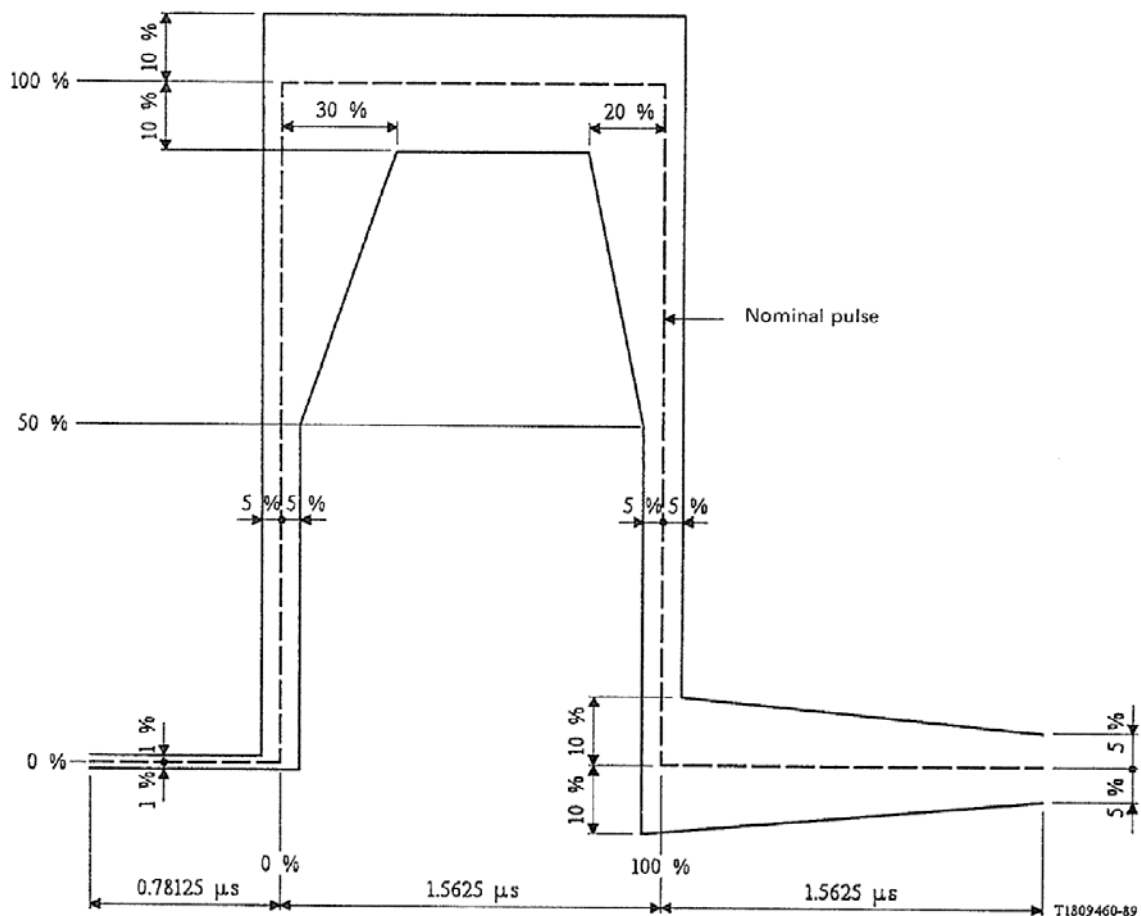

FIGURE IV-8/G.961

Transmitter output pulse mask

IV.12.3 *Signal power*

The average power shall be between 14.5 dBm and 17.1 dBm.

IV.12.4 *Power spectrum*

The upper bound of the power spectral density shall be within the template in Figure IV-9/G.961.

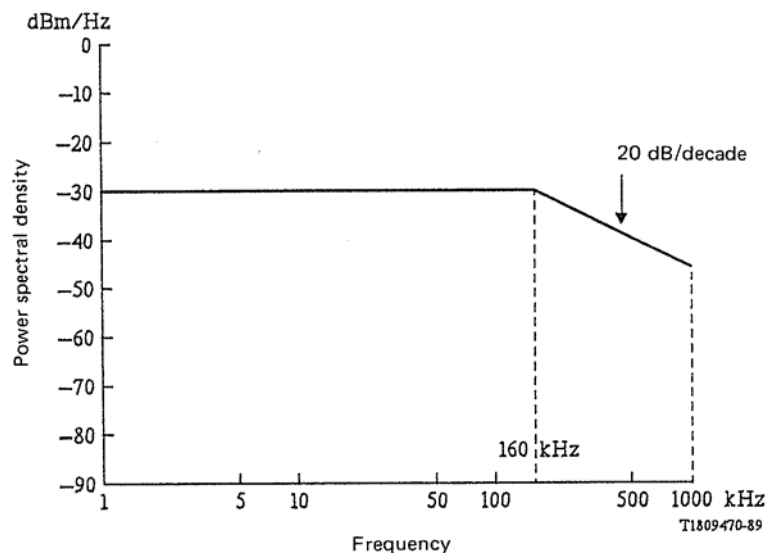

FIGURE IV-9/G.961

Upper bound of power spectral density of signal

IV.12.5 *Transmitter signal nonlinearity*

This is a measure of the deviations from ideal pulse heights and the individual pulse nonlinearity.

The deviation between positive and negative pulse heights shall be less than 5%.

The measurement method is for further study.

IV.13 *Transmitter/receiver termination*

IV.13.1 *Impedance*

- a) The nominal input impedance looking toward the NT1 or LT respectively shall be 110 ohms.
- b) The nominal output impedance looking toward the NT1 or LT respectively shall be less than 30 ohms when driving pulses, and shall be 110 ohms when not driving pulses.

IV.13.2 *Return loss*

The return loss of the impedance shall be greater than shown in the template Figure IV-10/G.961.

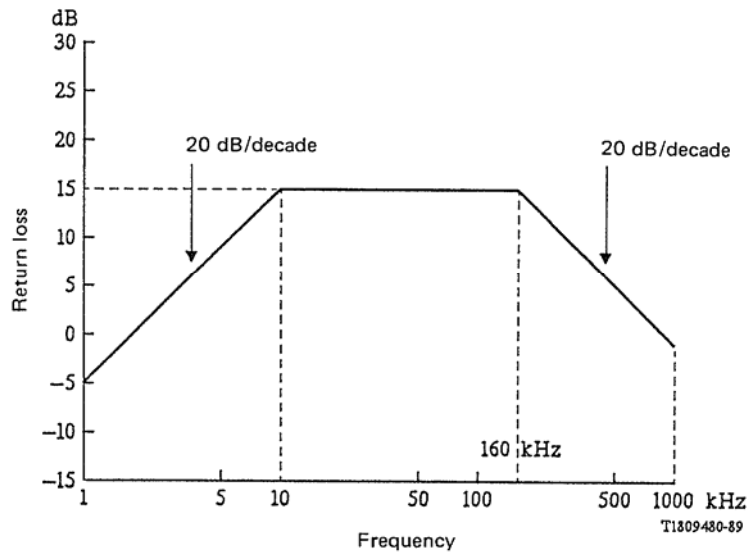

FIGURE IV-10/G.961

Minimum return loss of impedance

IV.13.3 *Longitudinal conversion loss*

The minimum longitudinal conversion loss shall be greater than shown in the template Figure IV-11/G.961.

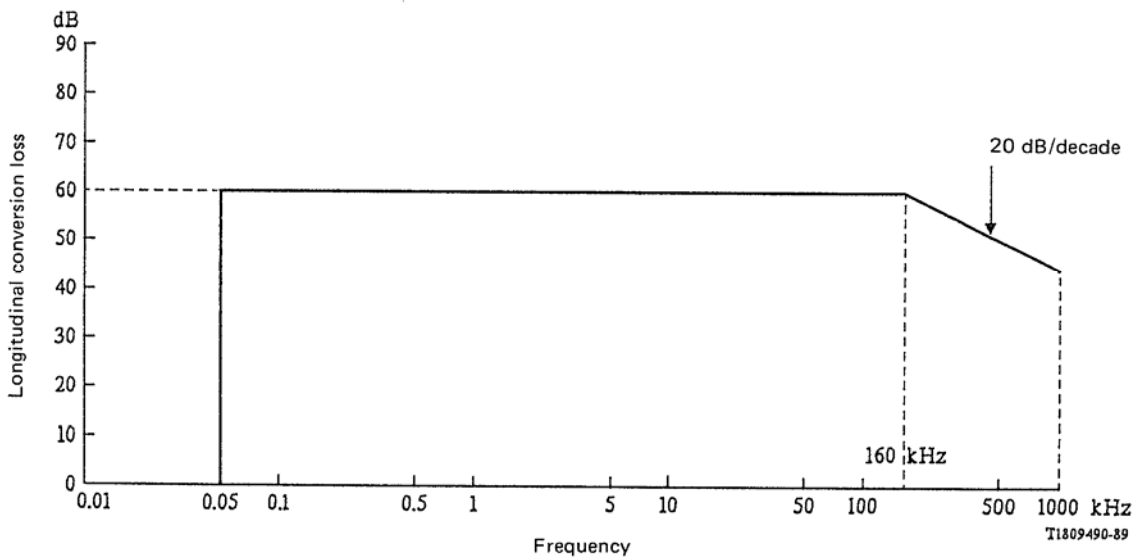

FIGURE IV-11/G.961

Minimum conversion loss

APPENDIX V

(to Recommendation G.961)

A digital line system for ISDN basic rate access using binary bi-phase line code

V.0 *Electrical characteristics*

This appendix describes a 160 kbit/s transparent transmission system using echo cancelling techniques. The transmission rate will support 64 kbit/s B channels and one 16 kbit/s D channel as defined in Recommendation I.412. The remaining 16 kbit/s capacity will allow for framing and auxiliary channel information.

Data scrambling is performed on the entirety of the framed data using different polynomials at exchange end and subscriber end. Bi-phase coding is used for the line code. The encoded signal is filtered and transmitted to the line at a symbol rate of 160 kbauds. The bi-phase signalling element transitions allow data-derived clock extraction with low jitter, and equalisation can be accomplished by a short decision-feedback structure. Binary decision-making gives best immunity to residual inter-symbol interference and residual echo and simplifies receiver design by not requiring AGC/decision references.

V.1 *Line code*

For both the directions of transmission the line code is bi-phase. The coding scheme is as follows.

Binary ZERO is represented by a negative transition in the middle of the bit period.

Binary ONE is represented by a positive transition in the middle of the bit period.

Transitions at the bit boundary occur if successive binary data bits are identical.

The encoded binary signal is then shaped to effectively filter out the high frequency components.

V.2 *Symbol rate*

The symbol rate is determined by the line code, the bit rate of the information stream and the frame structure. The symbol rate is 160 kbauds.

V.2.1 *Clock requirements*

V.2.1.1 NT1 free running clock accuracy

The accuracy of the free running clock in the NT1 shall be ± 230 ppm.

V.2.1.2 LT clock tolerance

The NT1 and LT shall accept a clock accuracy from the ET of ± 50 ppm in compliance with Recommendation G.703.

V.3 *Frame structure*

The frame structure contains a frame word, N times ($2B + D$) and a CL channel.

As shown in Figure V-1/G.961, a line frame is defined as 40 "cells" C0 to C39, each containing 19 bits at the transmission bit rate. Cell C0 contains a frame synchronization pattern.

Cells C1 to C19 and C21 to C39 contain the subscriber B1, B2, and D channels. Cell C20 contains a CL channel.

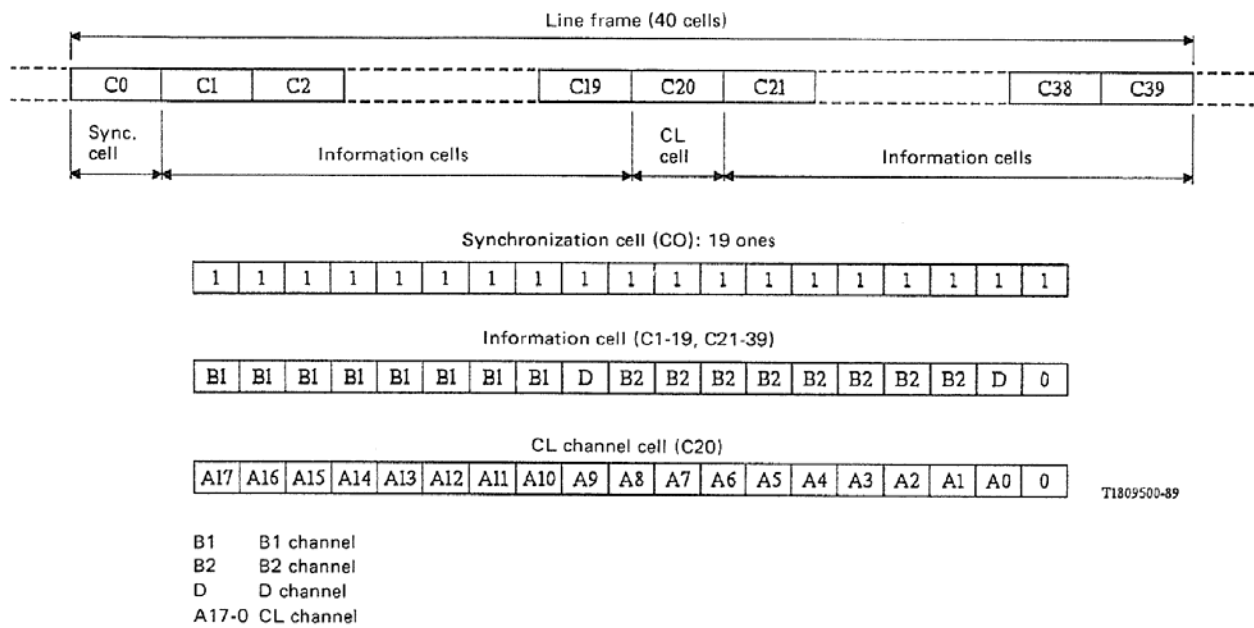

Note — Transmission order is from left to right.

FIGURE V-1/G.961
Frame structure

V.3.1 *Frame length*

The defined frame structure and line rate results in a line frame of 760 bits and of 4.75 ms duration.

V.3.2 *Bit allocation in direction LT-NTI*

As defined in § V.3.

V.3.3 *Bit allocation in direction NTI-LT*

As defined in § V.3.

V.4 *Frame word*

V.4.1 *Frame word in direction LT-NTI*

The frame word occupies cell C0 in the frame structure, and it consists of 19 consecutive ones, which is unique within the frame bit sequence. This is ensured by defining the 19th bit in cells C1 to C39 to be permanently set to zero.

V.4.2 *Frame word in direction NTI-LT*

As defined in § V.4.1.

V.5 *Frame alignment procedure*

A 20-bit alignment pattern of 19 consecutive ones immediately preceded by a zero shall be searched for in the incoming data stream. “Frame alignment” is defined as the correct reception of three consecutive frames containing the alignment pattern in the expected positions within the frames.

V.5.1 *Frame alignment monitoring*

“Loss of frame alignment”, is defined as the detection of 3 consecutive frames each with one or more errors in the alignment pattern. The monitoring of frame alignment shall be a continuous process.

V.5.2 *Line polarity detection*

In the NT1, a mechanism is provided for the automatic detection of the line polarity. An 80 ms timer is started only by the inactive to active transition of the “line signal detect” signal, from the transmission system. The timer is held reset when “frame alignment” is achieved. The expiry of the timer causes the incoming and outgoing data polarity to be reversed. Once the line polarity is determined it is retained as the initial polarity for subsequent detection operations. The timer duration of 80 ms is chosen to allow for the convergence of the transmission system, plus the time required to obtain “frame alignment”.

In order to avoid duplication of the alignment pattern by a data sequence in a data stream from a reversed line, the B1, B2 and D channels, in the LT to NT1 direction, are to be set to all ones during that part of the activation procedure before operational data is switched through. In addition, at least one bit of the auxiliary channel must also be set to a one during the activation procedure.

V.6 *Multiframe*

There is no multiframe structure.

V.7 *Frame offset between LT-NT1 and NT1-LT frames*

The LT-NT1 and NT1-LT frames at the NT1 can be in any alignment but the LT is required to align with any offset of the received line frames relative to the transmitted line frames.

V.8 *CL channel*

The purpose of the CL channel is to convey maintenance information as well as “date valid” and “ready for data” flags.

V.8.1 *Bit rate*

The bit rate of the CL channel is 3.8 kbit/s.

V.8.2 *Structure*

Figure V-2/G.961 shows the CL channel format in the two directions LT-NT1 and NT1-LT, which is divided into the following field types:

- a) M3-0: A 4 bit field for the conveyance of a “maintenance command” to a remote transmission termination. The termination identity is included in the command coding.
- b) R3-0: A 4 bit field for the conveyance of a “maintenance response” to the LT.
- c) DV: A “data valid” flag which indicates that, in the LT to NT1 direction, the B1, B2 and D channels contain operational data.
- d) RFD: A “ready for data” flag which indicates that, in the NT1 to LT direction, the B1, B2 and D channels contain operational data.
- e) D7-0: An 8 bit field for the conveyance of any “maintenance data” that may be associated with a “maintenance response”.
- f) K4-0: A 5 bit cyclic check code which operates on the auxiliary cell bits A17 to A5 inclusive.

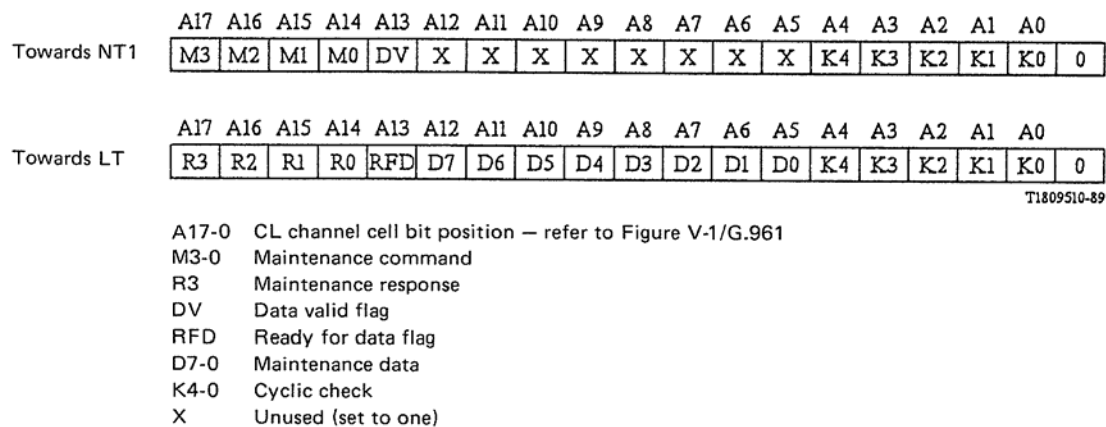

FIGURE V-2/G.961
CL channel format

V.8.3 *Protocols and procedures*

Maintenance operations are based on a repetitive command/echo-response protocol. A maintenance operation is initiated by the continuous transmission of the required “maintenance command” from the LT. When the appropriate termination receives the validated command, it is continuously echoed back to the LT as a “maintenance response”, and the command is acted upon. If the command demands data, then this is simultaneously returned in the “maintenance data” field. The termination continues to echo the command and provide any data for as long as it receives appropriate validated commands. For responses which are not accompanied by data, the “maintenance data” field is undefined. The LT assumes the conclusion of the maintenance operation when it receives a validated response that matches the transmitted command.

Loopbacks are applied using maintenance commands, and transmission system performance data is returned using the maintenance data field. Maintenance operations can be performed whenever the Digital Section is activated.

V.8.4 *Security*

A security mechanism operates on CL channel bits A17 to A0 inclusive.

The validation procedure consists of two stages:

- a) A 5 bit cyclic redundancy code K4-0 operates on CL channel bits A17 to A5 inclusive. The generator of the code is:

$$g(x) = (1 \oplus x)(1 \oplus x \oplus x^4)$$

This is a Hamming code which gives single bit error detection and single bit error correction.

- b) A set of CL channel bits A17 to A5 are only accepted as valid if they have been successfully checked/corrected and they match the previous two sets which were successfully checked/corrected. Note that these three sets need not necessarily have come from consecutive line frames.

V.9 *Scrambling*

The entirety of the framed binary data stream is scrambled as follows:

- a) NT1 to LT scramble polynomial

$$1 \oplus x^{-14} \oplus x^{-15}$$

b) LT to NT1 scramble polynomial

$$1 \oplus x^{-1} \oplus x^{-15}$$

(\oplus = EXCLUSIVE OR)

V.10 *Activation/deactivation*

One bit of the CL channel is allocated for use during the activation and deactivation procedures. These are the “data valid” flag in the LT to NT1 direction and the “ready for data” flag in the NT1 to LT direction. These bits are not included in the maintenance protocol described above, and operate as simple unsolicited indications.

V.10.1 *Signals used for activation/deactivation*

The signals (SIGs) used for activation/deactivation are:

LT-NT1 direction

Signal	Frame word	2B + D	M	DV	K
I0	Absent	Absent	Absent	Absent	Absent
I2	Normal	1	1	0	Normal
I4	Normal	Normal	Normal	1	Normal

NT1-LT direction

Signal	Frame word	2B + D	R	RFD	D0-D7	K
I0	Absent	Absent	Absent	Absent	Absent	Absent
I1	0	0	0	0	0	0
I31	Normal	0	1	0	Normal	Normal
I3	Normal	Normal	Normal	1	Normal	Normal

V.10.2 *Definition of internal timers*

The following timers are located within the LT:

- Timer 2 (T2) prevents unintentional reactivation from the TE.
- Timer A (TA) is started if, from the layer 1 active state (LT4), SIG I31 is received, indicating loss of SIG I3. If SIG I3 is not subsequently received before expiry of Timer A, deactivation is initiated.
- Timer B (TB) is started upon loss of framing. If frame recovery is not achieved before expiry of Timer B, deactivation is initiated.

Durations of internal timers are for further study.

V.10.3 *Description of activation/deactivation procedures*

Figure V-3/G.961 (sheet 1 of 3) illustrates the method of activation from the network. PH ACTIVATE REQUEST causes SIG I2 to be transmitted from the network towards NT1. NT1 achieves line signal detect and frame synchronization status. At this point NT1 sends INFO 2 towards the TE and simultaneously sends SIG I31 towards the network. In time, the network achieves in synchronization status and the TE replies to INFO 2 with INFO 3. The latter event is signalled to the network from NT1 by sending SIG I3. At the network this results in ACTIVATE INDICATION. The network responds by sending SIG I4 towards NT1. Upon receipt of this signal NT1 sends INFO 4 towards the TE, thus completing the activation procedure.

Figure V-3/G.961 (sheet 2 of 3) illustrates activation from the user side. The activation process is essentially similar to that for activation from the network side, except that INFO 1 from the TE begins the process. In this case NT1 starts the process by sending SIG I1 towards the network. Line signal detect status is achieved at the network. The network sends SIG I2 towards NT1. From here on the process is as described above.

Figure V-3/G.961 (sheet 3 of 3) illustrates the method of deactivation. DEACTIVATE REQUEST causes transmission from the network to NT1 to cease (SIG I0). The NT1, on detecting this, sends SIG I1 back to the network, and INFO 0 towards the TE. The TE responds by sending INFO 0 back to the NT1, and on receipt of this, the NT1 ceases transmitting to the network (SIG I0). At the network, this results in DEACTIVATE INDICATION, thus completing the deactivation procedure.

Definitions for SIGs are given in V.10.1 and for definitions for INFOS refer to Recommendation I.430.

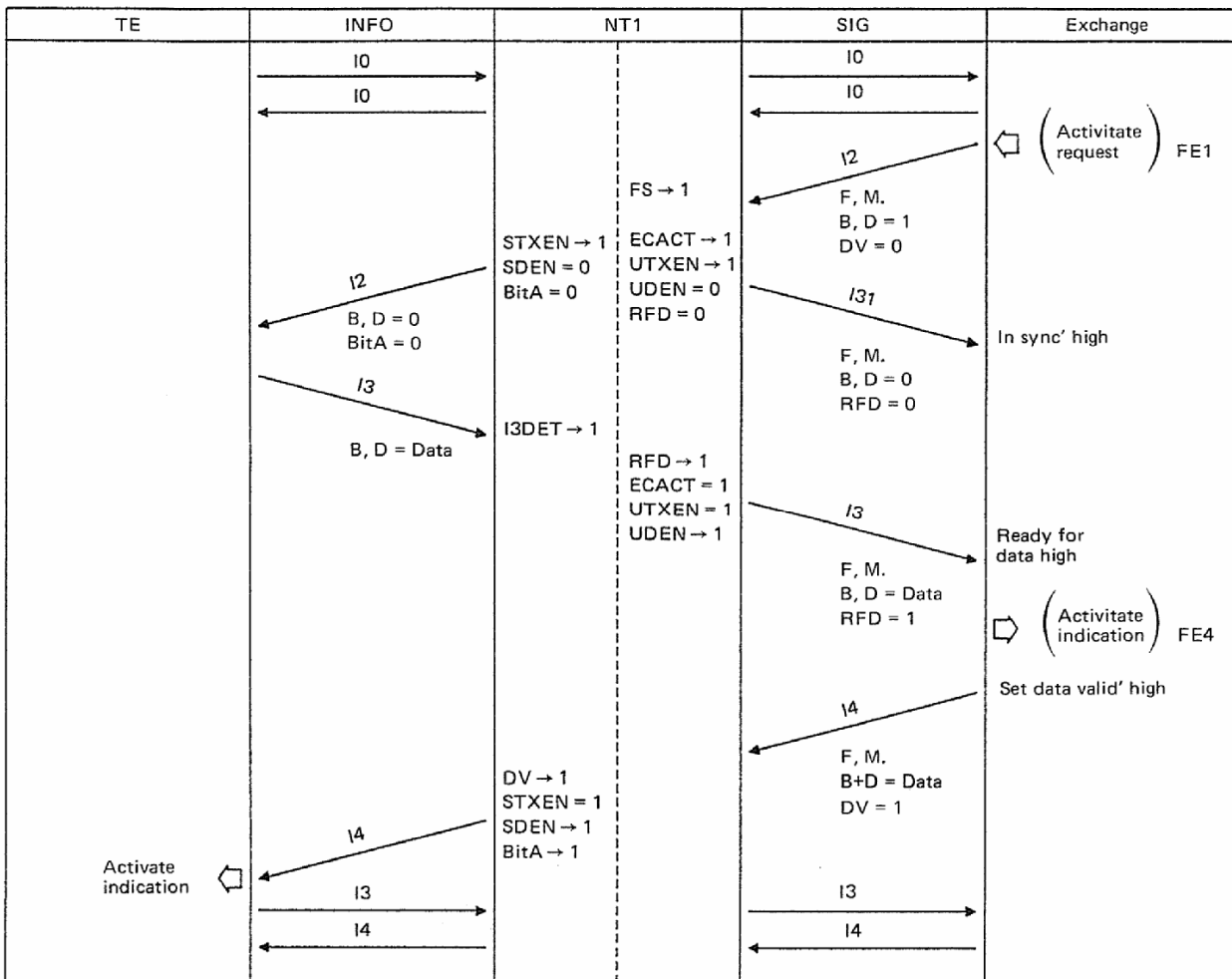

T1809520-89

FIGURE V-3/G.961 (Sheet 1 of 3)

Activation from network side – activation initiated by exchange

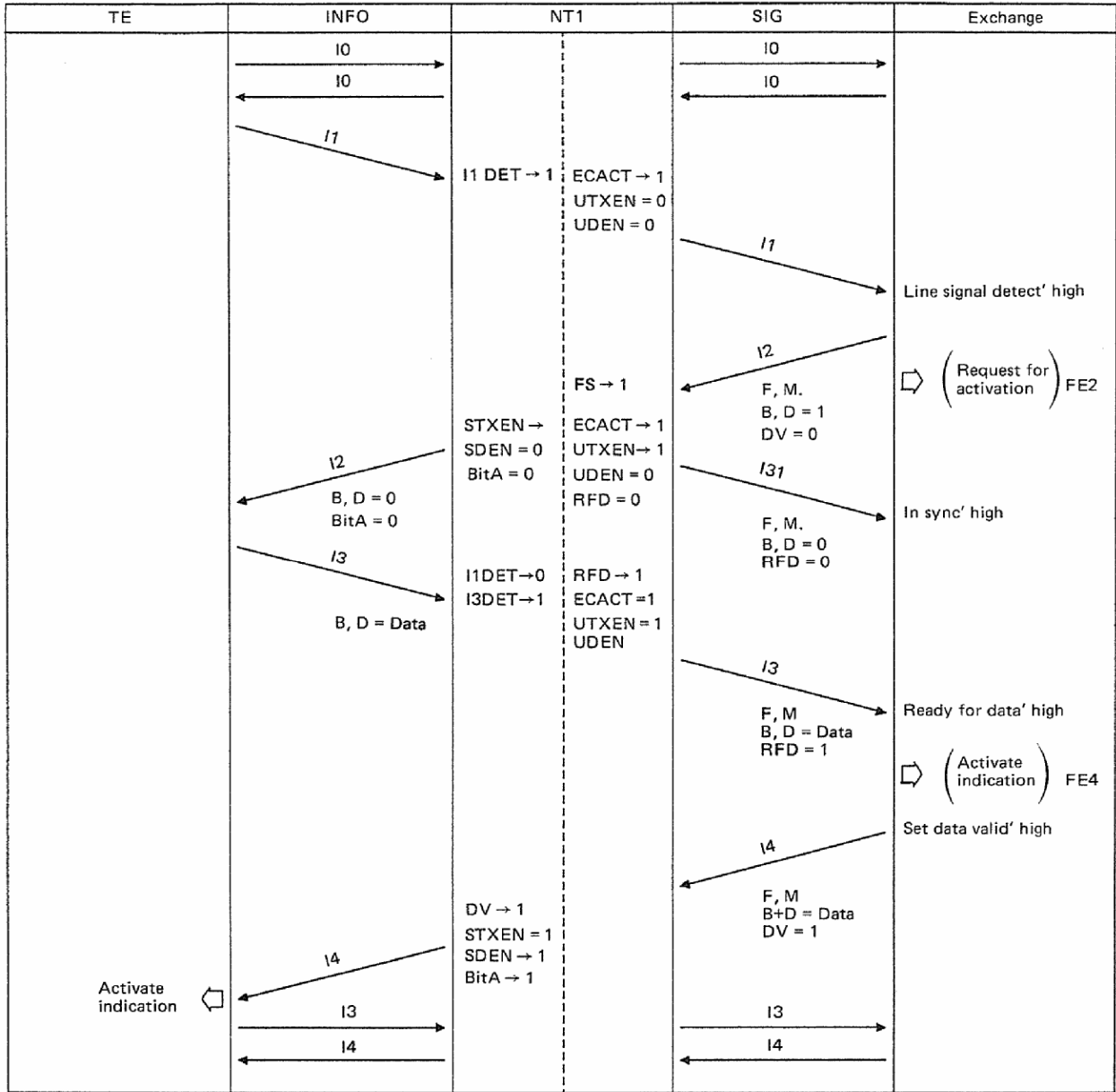

TI809530-89

FIGURE V-3/G.961 (Sheet 2 of 3)

Activation from user side – activation initiated by terminal

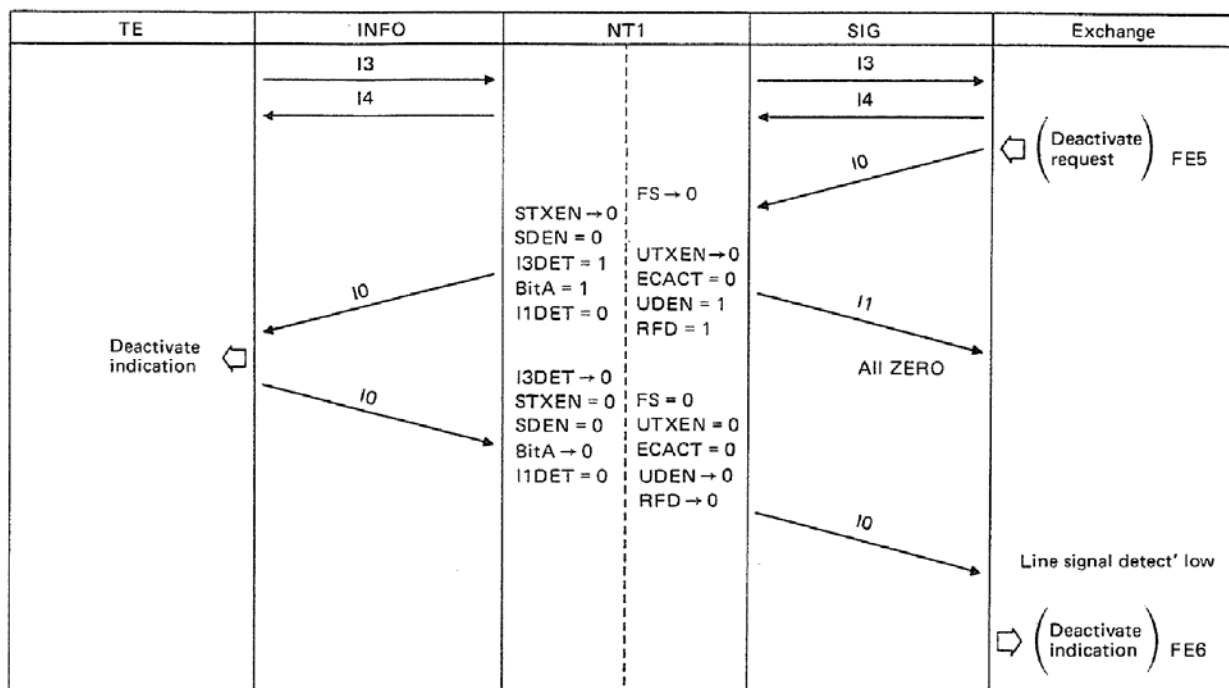

T1209540-89

FIGURE V-3/G.961 (Sheet 3 of 3)

Deactivation

V.10.4 State transition table for NT1 as a function of INFOs, SIGs

See Table V-1/G.961.

V.10.5 State transition table for LT as a function of FEs, SIGs, and internal timers

See Table V-2/G.961.

V.10.6 Activation times

Metallic pair cable transmission system.

Maximum activation time occurring immediately after a deactivation (without intervening loopback or powering action):

- a) without regenerator: 100 ms;
- b) with regenerator: 200 ms.

Maximum activation time occurring after the first powering of a line:

- a) without regenerator: 250 ms;
- b) with regenerator: 500 ms.

V.11 Jitter

Jitter tolerances are intended to ensure that the limits of Recommendation I.430 are supported by the jitter limits of the transmission system on local lines.

TABLE V-1/G.961

NT1 activation/deactivation state transition table

States		NT1 Deact.	NT2 Act. pendg.	NT3 System. act.	NT4 Wait data valid	NT5 Layer 1 act.
Events	SIG transmitted	I0	I1	I31	I3	I3
SIG received	I0 (Deact. req.)	–	–	I0 NT1	I0 NT1	I0 NT1
	I2 (Act. req.)	I2 NT3	I2 NT3	–	–	I2 NT3
	I4 (Dat. valid)	/	I2 NT3	/	I4 NT5	–
From TE	I0 (Deact. req.)	–	I0 NT1	–	– NT3	I2 NT3
	I1 (Act. req.)	– NT2	–	/	/	/
	I3 (Act. ind.)	– NT2	–	– NT4	–	–

/ No change

– Impossible

TABLE V-2/G.961

LT activation/deactivation state transition table

States		LT1 Deact.	LT2 Wait for systm. act	LT3 Systm act.	LT4 Layer 1 act.	LT5 Loss of frang.	LT6 Wait for deact.
Events	SIG transmitted	I0	I2	I2	I4	(Note)	I0
SIG received	I0 (Deact. ind.)	–	–	FE7 –	FE7 –	–	FE6 LT1
	I1 (Act. req.)	FE2 TL2	–	/	/	/	–
	I31 (System activated)	/	FE3 LT3	–	Start TA LT3	/	–
	I3 (Layer 1 activated)	/	/	Stop TA FE4 LT4	–	/	/
Internal event	Loss of framing	/	/	Start TB LT5	Start TB LT5	/	–
	Frame recovery	/	/	/	/	Stop TB LT3	–
	Expiry of timer 2	–	–	–	–	–	FE6 LT1
	Expiry of timer A	–	–	Start T2 FE7 LT6	–	–	–
	Expiry of timer B	–	–	–	–	Start T2 FE7 LT6	–
Function element received	FE1	– LT2	/	/	/	/	– LT2
	FE5	–	Start T2 LT6	Start T2 LT6	Start T2 LT6	Start T2 LT6	–

– No change

/ Impossible

Note – The SIG transmitted by the LT when framing is lost will not change from that transmitted immediately prior to the loss (i.e. I2 or I4).

Meaning of symbols for Tables V-1/G.961 and V-2/G.961

States at NT

NT1	Deactivated
NT2	Activation pending
NT3	Transmission system activated
NT4	Wait for data valid
NT5	Layer 1 activated

States at LT

LT1	Deactivated
LT2	Waiting for transmission system activation
LT3	Transmission system activated
LT4	Layer 1 activated
LT5	Loss of framing
LT6	Waiting for deactivate indication
ST.T2	Start timer T2
STP.TA	Stop timer TA

Function element definitions are as in Recommendation G.960.

V.11.1 *NT1 input signal jitter tolerance*

For further study.

V.11.2 *NT1 output jitter limitations*

For further study.

V.11.3 *Test conditions for jitter measurements*

For further study.

V.12 *Transmitter output characteristics of NT1 and LT*

The following specifications apply with a load impedance of 140 ohms.

V.12.1 *Pulse amplitude*

The nominal peak amplitude of a transmitted signal pulse shall be 1.6 V, and the tolerance shall be $\pm 5\%$.

V.12.2 *Pulse shape*

The pulse shape shall be as shown in Figure V-4/G.961.

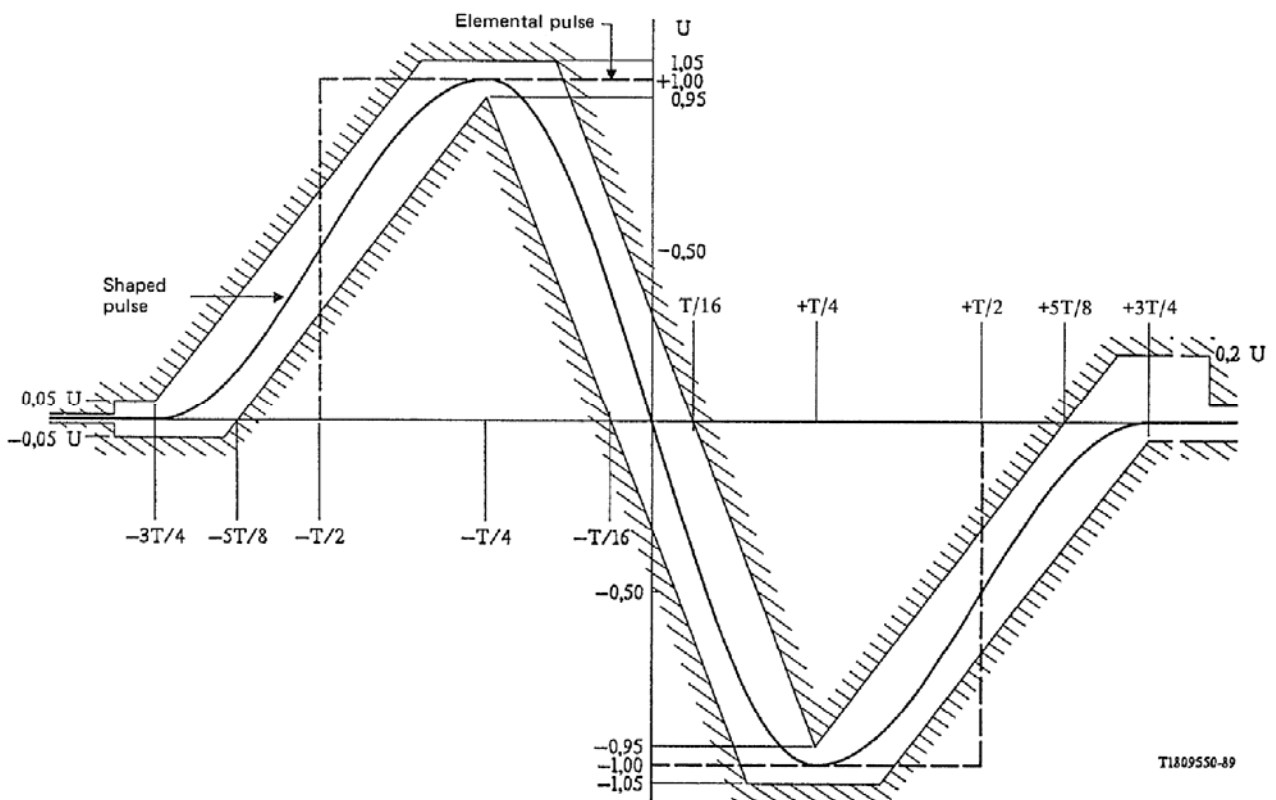

FIGURE V-4/G.961

Pulse shape

V.12.3 *Signal power*

The maximum total transmit power, averaged in any one second period, sent down to the line shall be +10 dBm.

V.12.4 *Power spectrum*

The upper bound of the power spectral density, averaged in any one second period in any 3 kHz band, shall be limited as shown in the template Figure V-5/G.961.

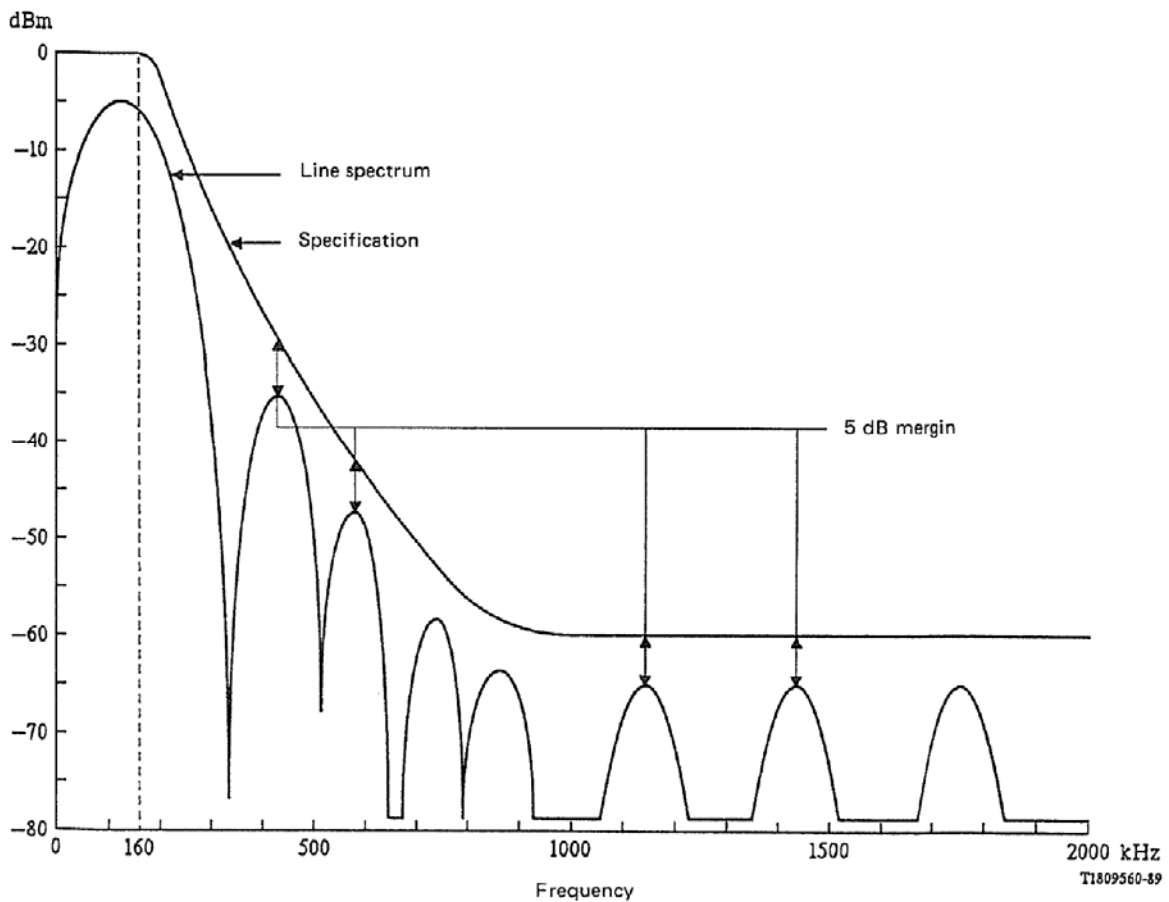

FIGURE V-5/G.961

Line signal power spectrum

V.12.5 *Transmitter signal nonlinearity*

This is a measure of the deviations from ideal pulse heights and the individual pulse nonlinearity. For further study.

V.13 *Transmitted/receiver termination*

V.13.1 *Impedance*

The nominal line driving impedance shall be 140 ohms.

V.13.2 *Return loss*

The return loss of the impedance (against 140 ohms) shall be greater than shown in the template Figure V-6/G.961.

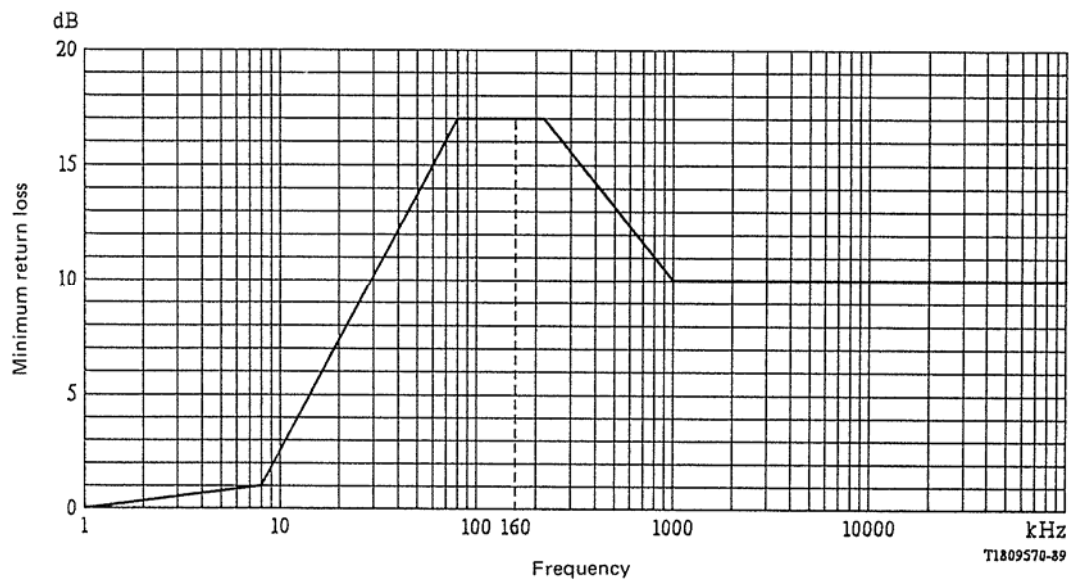

FIGURE V-6/G.961

Return loss

V.13.3 *Longitudinal conversion loss*

This is a measure of the immunity from longitudinal voltages. In the frequency band 100 Hz to 256 kHz, the conversion loss shall not be less than 46 dB. From 256 kHz to 4 MHz, the conversion loss shall not be less than $[46 - 40 \log_{10} (f/256)]$ dB (where f is frequency in kHz).

APPENDIX VI

(to Recommendation G.961)

Basic access transmission system using SU32 line code

VI.0 *General*

The SU32 standard will support the full duplex, transparent transmission of two 64 kbit/s B channels and one 16 kbit/s D channel over symmetric pair cables using echo cancelling techniques. In addition to transparent 2B + D transmission, 5.3 kbit/s capacity is provided for an Auxiliary channel supporting data CRC, control, supervisory and maintenance functions. The bit stream is encoded for transmission using a high performance ternary SU32 (substitutional 3B2T) conditional block code, filtered and transmitted to line at a baud rate of 108 kbauds. An orthogonal timing signal is superimposed on the line code for symbol sampling; which does not compromise either the line code efficiency or performance. A unique synchronisation word is used to achieve frame synchronisation. Fast and reliable activation is ensured by means of a binary handshake procedure, for separate training of canceller and equaliser.

VI.1 *Line code*

The binary data is encoded into a ternary form using the SU32 line code. This is based on the fixed and unconditional 3B2T line code and modified as follows. Each binary triplet is converted to a ternary duplet and is transmitted unless it is identical to the previously transmitted duplet. If current and previous duplets are identical, then the un-used code word "00" is transmitted in its place. The SU32 coding rule is shown in Table VI-1/G.961. In this Table, the left most bit is the first into the encoder and the left most symbol the first out of the encoder.

TABLE VI-1/G.961

SU32 coding (substitutional 3B2T)

Binary I/P	Ternary O/P	Binary I/P	Ternary O/P
000	--	100	0-
001	-0	101	+ -
010	-+	110	+0
011	0+	111	++

Decoding

Decoding of the received signal is the inverse of the coding process.

Tolerance to line polarity inversion

The code is symmetric so that inversion of the ternary data results in an inversion of the decoded binary data. Thus polarity correction due to cable inversion can be applied either to scrambled or unscrambled binary data, or to ternary data. Both transmitted and received polarity correction is performed at the NT1.

VI.2 *Symbol rate*

The symbol rate is determined by the line code, the bit rate of the information stream and the frame structure. The symbol rate is 108 kbauds.

VI.2.1 *Clock tolerance*

VI.2.1.1 *NT1 free running clock accuracy*

The tolerance of the NT free running clock shall be ± 192 ppm.

VI.2.1.2 *Tolerance of the free running clock in the LT*

The free running clock in the LT will be phase locked to the exchange clock having a frequency tolerance of ± 50 ppm thus permitting operation with any equipment meeting Recommendation G.703.

VI.3 *Frame structure*

There are two states of operation of the transmission system, steady state and training state. The frame structure covered in this section is for the steady state (information transfer).

The B1, B2, D and CL channels map directly from binary bits through the scrambler into the ternary frame structure. The SU32 code table is designed to exclude certain uniquely identifiable code sequences, which are exploited for synchronisation purposes.

Multiframe: Multiframe word and location

The 12 ms multiframe is identified every 16th 3/4 ms frame by replacing the CRC data symbol (No. 79) with a ternary “0”. In all other frames, this symbol is binary valued. This, combined with the frame synchronisation word preceding it, uniquely identifies the position of the start of the superframe.

Multiframe Format

A multiframe consists of sixteen 81-ternary-symbol 0.75 ms frames.

6 frames of 2B + D	Frame word	CRC ₁	CL-channel ₁₁
6 frames of 2B + D	Frame word	CRC ₂	CL-channel ₂
6 frames of 2B + D	Frame word	CRC ₃	CL-channel ₃
6 frames of 2B + D	Frame word	CRC ₄	CL-channel ₄
6 frames of 2B + D	Frame word	CRC ₅	CL-channel ₅
6 frames of 2B + D	Frame word	CRC ₆	CL-channel ₆
6 frames of 2B + D	Frame word	CRC ₇	CL-channel ₇
6 frames of 2B + D	Frame word	CRC ₈	CL-channel ₈
6 frames of 2B + D	Frame word	CRC ₉	CL-channel ₁
6 frames of 2B + D	Frame word	CRC ₁₀	CL-channel ₂
6 frames of 2B + D	Frame word	CRC ₁₁	CL-channel ₃
6 frames of 2B + D	Frame word	CRC ₁₂	CL-channel ₄
6 frames of 2B + D	Frame word	CRC ₁₃	CL-channel ₅
6 frames of 2B + D	Frame word	CRC ₁₄	CL-channel ₆
6 frames of 2B + D	Frame word	CRC ₁₅	CL-channel ₇
6 frames of 2B + D	Frame word	“0”	CL-channel ₈

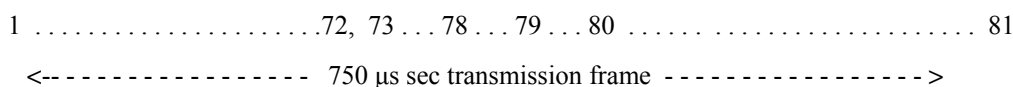

12 ms multiframe structure

Note – B1, B2, D and CL channel data is scrambled. CRC data and frame words are not scrambled.

VI.3.1 *Frame length*

There are 6 (2B + D) slots in each 3/4 ms 81 symbol frame.

VI.3.2 *Binary bit allocation in direction LT to NT*

The following binary bit ordering is applied before scrambling.

B1 ₁	B1 ₂	B1 ₃	B1 ₄	B1 ₄	B1 ₅	B1 ₆	B1 ₇	B1 ₈	B2 ₁	B2 ₂	B2 ₃	B2 ₄	B2 ₅	B2 ₆	B2 ₇	B2 ₈	D ₁	D ₂
B1 ₁	B1 ₂	B1 ₃	B1 ₄	B1 ₄	B1 ₅	B1 ₆	B1 ₇	B1 ₈	B2 ₁	B2 ₂	B2 ₃	B2 ₄	B2 ₅	B2 ₆	B2 ₇	B2 ₈	D ₁	D ₂
B1 ₁	B1 ₂	B1 ₃	B1 ₄	B1 ₄	B1 ₅	B1 ₆	B1 ₇	B1 ₈	B2 ₁	B2 ₂	B2 ₃	B2 ₄	B2 ₅	B2 ₆	B2 ₇	B2 ₈	D ₁	D ₂
B1 ₁	B1 ₂	B1 ₃	B1 ₄	B1 ₄	B1 ₅	B1 ₆	B1 ₇	B1 ₈	B2 ₁	B2 ₂	B2 ₃	B2 ₄	B2 ₅	B2 ₆	B2 ₇	B2 ₈	D ₁	D ₂
B1 ₁	B1 ₂	B1 ₃	B1 ₄	B1 ₄	B1 ₅	B1 ₆	B1 ₇	B1 ₈	B2 ₁	B2 ₂	B2 ₃	B2 ₄	B2 ₅	B2 ₆	B2 ₇	B2 ₈	D ₁	D ₂
B1 ₁	B1 ₂	B1 ₃	B1 ₄	B1 ₄	B1 ₅	B1 ₆	B1 ₇	B1 ₈	B2 ₁	B2 ₂	B2 ₃	B2 ₄	B2 ₅	B2 ₆	B2 ₇	B2 ₈	D ₁	D ₂
CL ₁	CL ₂	CL ₃																

The binary data is scrambled as defined in § VI.9 and ternary encoded. It is then multiplexed into the following frame format.

T ₁	T ₂	T ₃	T ₄	T ₅	T ₆	T ₇	T ₈	T ₉	T ₁₀	T ₁₁	T ₁₂	
T ₁₃	T ₁₄	T ₁₅	T ₁₆	T ₁₇	T ₁₈	T ₁₉	T ₂₀	T ₂₁	T ₂₂	T ₂₃	T ₂₄	
T ₂₅	T ₂₆	T ₂₇	T ₂₈	T ₂₉	T ₃₀	T ₃₁	T ₃₂	T ₃₃	T ₃₄	T ₃₅	T ₃₆	
T ₃₇	T ₃₈	T ₃₉	T ₄₀	T ₄₁	T ₄₂	T ₄₃	T ₄₄	T ₄₅	T ₄₆	T ₄₇	T ₄₈	
T ₄₉	T ₅₀	T ₅₁	T ₅₂	T ₅₃	T ₅₄	T ₅₅	T ₅₆	T ₅₇	T ₅₈	T ₅₉	T ₆₀	
T ₆₁	T ₆₂	T ₆₃	T ₆₄	T ₆₅	T ₆₆	T ₆₇	T ₆₈	T ₆₉	T ₇₀	T ₇₁	T ₇₂	
0	0	0	0	0	0	VRC	T ₇₃	T ₇₄				

VI.3.3 *Binary bit allocation in direction NT1 to LT*

The frame structure and order of bits in the NT1 to LT direction is to identical that used in the LT to NT1 direction specified in § VI.3.2 above.

VI.4 *Frame word*

The frame word of six ternary zeros terminated by the binary CRC₁₅ bit (as illustrated in the above Table) is used to define the 0.75 ms frame boundaries. Note that once every superframe a ternary zero is substituted for the binary CRC check bit. This frame word is unique and cannot be emulated by any 2B + D data pattern.

The frame word specified above is the same in both directions of transmission.

VI.5 *Frame alignment procedure*

The frame alignment function is specified in the Activation sequence. 2B + D transmission cannot commence unless frame alignment has been achieved. Initial frame alignment is considered to have been achieved when the cumulative total of correct versus incorrectly received 7-bit frame words exceeds 4. In steady state operation, this cumulative count is maintained but limited to a maximum of 64. Frame alignment loss is flagged if this cumulative total falls below two.

VI.6 *Multiframe*

The multiframe structure has been described in the frame structure, § VI.3 of this Appendix.

VI.7 *Frame offset between LT-NT1 and NT1-LT frames*

No specific phase requirements are necessary between frames in the LT-NT1 and NT1-LT directions.

VI.8 *CL channel*

An embedded protected operations channel (EPOC) of 4 kbit/s is partially allocated to supervisory and maintenance functions. Significant spare capacity and undefined bits remain for both future allocation of messages as well as specific national requirements.

This channel is protected by a 6-bit CRC check and compelled protocol which provides that all messages are repeated every 6 ms.

VI.8.1 *Bit rate*

Twenty-four bits per 6 ms multiframe (4 kbit/s) are allocated to an embedded protected operations channel (EPOC). This supports supervisory and maintenance functions between the network and the NT1 and includes spare capacity for user defined functions. Additionally a further 1.33 kbit/s is allocated to provide an error detecting CRC15 and 12 ms framing to the CL channel.

VI.8.2 *Structure*

Within each 12 frame, the operations channel sends two consecutive messages of 24 bits. Each 24 bit message comprises:

- 1 bit Ready for data/data valid (R).
- 5-bit Maintenance channel (M).
- 9-bit Supervisory channel (S).
- 3 Unassigned bits (500 bit/s subsidiary channel).
- 6-bit Cyclic redundancy check field (CRC).

The structure of the CL channel is as follows:

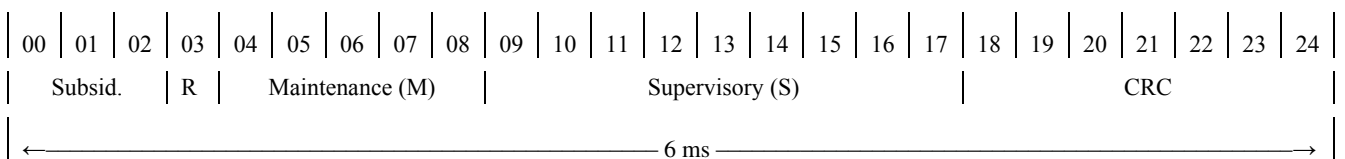

VI.8.2.1 *Maintenance messages*

In the ET to NT1 direction 9 of the 32 possible command messages are allocated. An identical message is returned in the NT1 to ET direction as an acknowledgement.

<i>ET to NT1 maintenance message codes</i>						
No.	Message	5-bit code				
		M1	M2	M3	M4	M5
1	No loopback (null message)/remove loopback	1	1	1	1	1
2	Provide loopback B1 at NT1	1	1	0	1	1
3	Provide loopback B2 at NT1	1	0	1	1	1
4	Provide loopback B1 + B2 at NT1	1	0	0	1	1
5	Provide loopback B1 + B2 + D at NT1	1	0	0	0	1
6	Provide loopback B1 at regenerator	0	0	1	1	1
7	Provide loopback B2 at regenerator	0	1	0	1	1
8	Provide loopback B1 + B2 at regenerator	0	1	1	1	1
9	Provide loopback B1 + B2 + D loopback at regenerator	0	1	1	0	1

Supervisory sub-channel message formats

A 9-bit field is available in each direction of transmission to allow supervisory information to be provided. This contains an 8-bit data/address field and a one-bit flag used to indicate whether or not the 8-bit field contains valid data.

<i>ET to NT1 supervisory message command codes</i>		
No	Supervisory message and destination	S-interface
1	No supervisory information requested	1 1111 1111
2	ET AGC value	0 0000 0100
3	ET eye closure	0 0000 0101
4	ET eye height	0 0000 0110
5	ET CRC error count	0 0000 0111
6	NT1 AGC value	0 0001 0000
7	NT1 Eye closure	0 0001 0001
8	NT1 Eye height	0 0001 0010
9	NT1 CRC error count	0 0001 0011
11	Regenerator LT-side receiver AGC	0 0000 1000
12	Regenerator LT-side receiver Eye closure	0 0000 1001
13	Regenerator LT-side receiver Eye height	0 0000 1010
14	Regenerator LT-side receiver CRC count	0 0000 1011
15	Regenerator NT1-side receiver AGC	0 0000 1100
16	Regenerator NT1-side receiver Eye closure	0 0000 1101
17	Regenerator NT1-side receiver Eye height	0 0000 1110
18	Regenerator NT1-side CRC count	0 0000 1111

VI.8.3 Protocols and procedures

The maintenance channel is used to set loop backs from the LT. When a maintenance message has been received free from error and implemented, the same message is echoed back from the NT1 to the LT.

The supervisory channel is designed to be used as a compelled system, with a command sent by the LT end until the expected response is received. A delimiting idle message of nine ONEs is employed. All valid messages and responses set the first bit of the 9 supervisory bits to a ONE. An 8 bit word can therefore be securely passed across this channel. An example use of the supervision channel is for reporting eye closure information from the NT1 to the LT.

VI.8.4 *CL channel performance*

With a mean 144 kbit/s error rate of 1 in 1000, characterised by a mean error burst size of 10, the following performance will be achieved:

- a) 99.8% of all messages will be conveyed within 6 ms.
- b) No more than one message per hour shall be conveyed in more than 18 ms.
- c) The mean erroneous error message rate is less than one per hour with a maximum time to correction of 18 ms.

VI.9 *Scrambling*

B1, B2, D and C channel binary data is scrambled as follows:

- a) NT to LT scrambler polynomial

$$1 \oplus x^{-18} \oplus x^{-23} \text{ (where } \oplus \text{ denotes exclusive OR)}$$

- b) LT to NT scrambler polynomial

$$1 \oplus x^{-5} \oplus x^{-23}$$

VI.10 *Activation/deactivation*

VI.10.1 *Signals used for activation*

Figure VI-1/G.961 illustrates the activation sequence initiated by the ET in terms of function elements (FE) and INFO's.

Figure VI-2/G.961 illustrates the activation sequence initiated by the user in terms of function elements (FE) and INFO's.

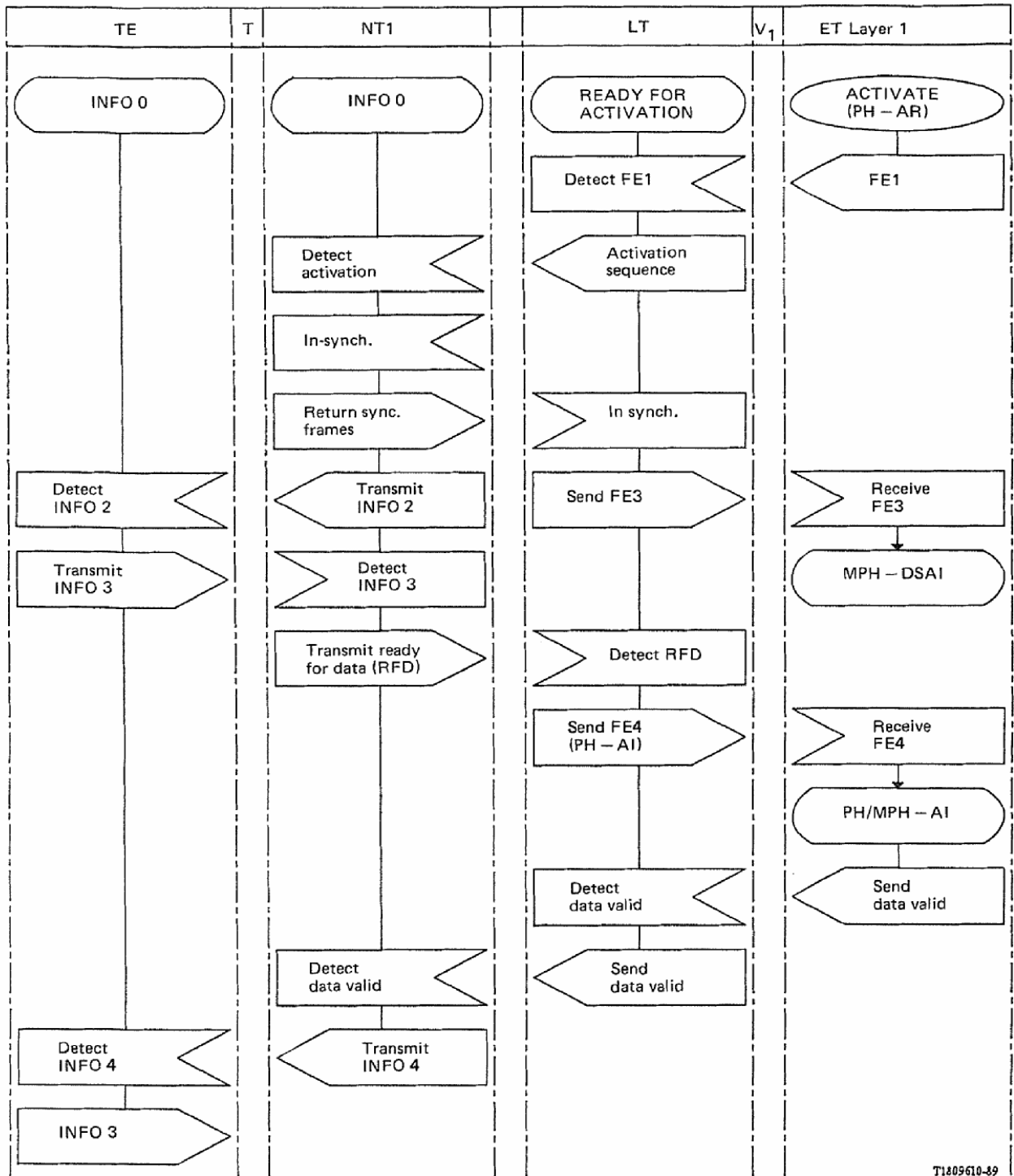

T1205610-49

FIGURE VI-1/G.961

Activation from the network side

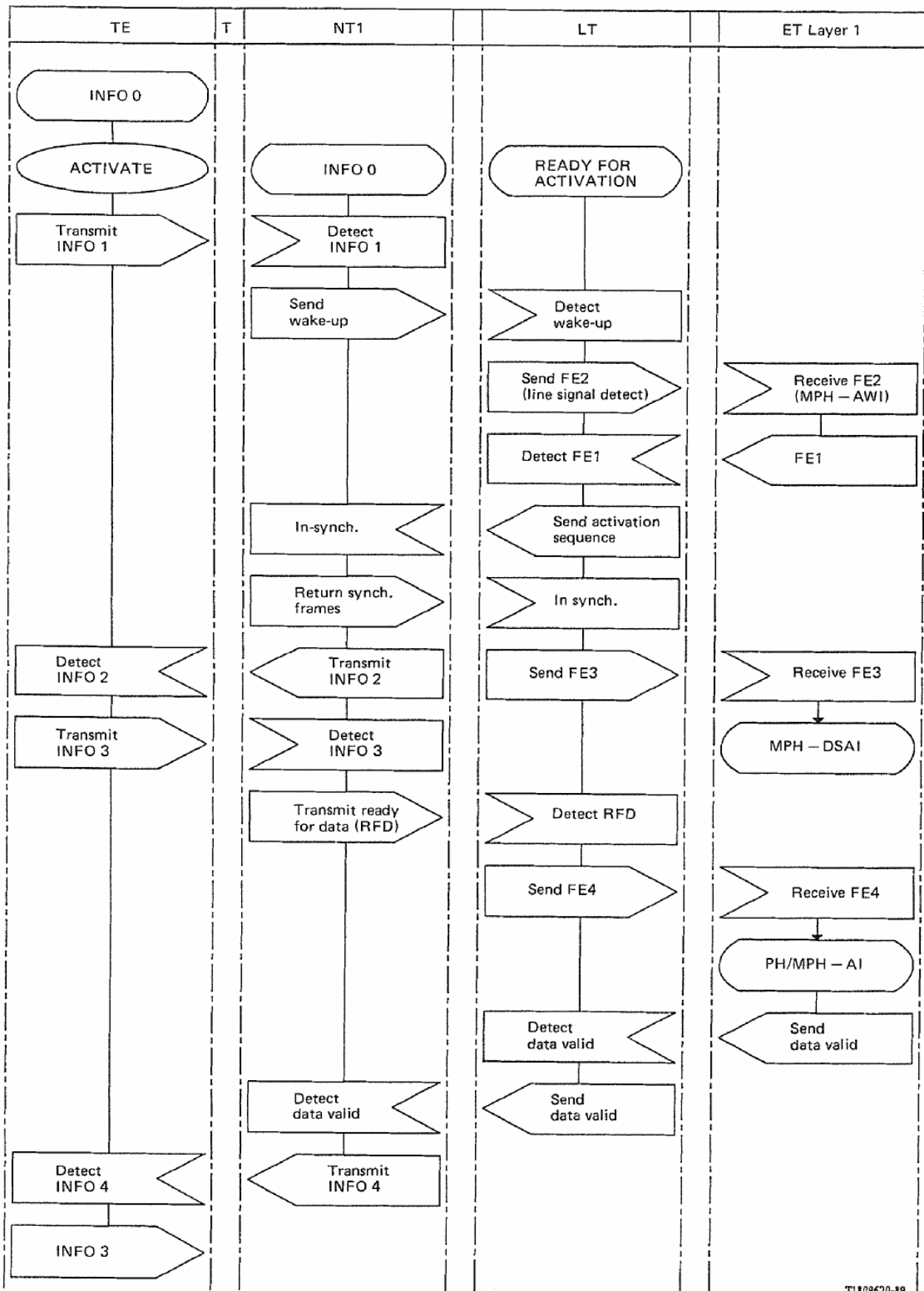

T1809620-89

FIGURE VI-2/G.961
Activation from the user side

The definition of the function elements, LT states and NT states used in the activation Figures and the state transition tables in this Appendix is as follows.

Definition of FE's LT's and NT's	
	Function elements (FE)
FE1	Activation request for the interface from the ET.
FE2	Line signal detected on the digital section.
FE3	The digital section is activated (in synchronisation).
FE4	The user network at the T reference point is activated or a loopback is operated.
FE5	Deactivation request for the digital section.
FE6	The digital section and the interface at the T reference point has been de-activated.
FE7	Error indication. (Loss of synchronisation or no line signal detect).
	NT1 states
NT1	The NT1 is ready for activation.
NT2	The NT1 is executing the digital section training sequence.
NT3	The NT1 is in synchronisation with the LT and the LT to NT1 digital section is capable of error free data transmission.
NT4	Equivalent to state NT3 plus synchronisation of the interface at the T-reference point.
NT5	The 2B + D data channel through the digital section and across the T reference point is fully operational.
NT6	The NT1 has sent an activate request to the LT and is waiting for a response.
NT7	The NT1 is not active but is not ready for activation.
	LT states
LT1	The LT is ready for activation.
LT2	The LT is executing the digital section training sequence.
LT3	The digital section has been correctly activated and is synchronised in both directions.
LT4	Both the digital section and the interface at the T reference point are correctly activated and synchronised.
LT5	The 2B + D data channel through the digital section and across the T reference point is fully operational.
LT7	The LT has ceased transmission over the digital section and is waiting for all line signals to disappear.

The response of the digital section to the activation request FE1 from the ET or the activation request INFO 1 from the TE is to signal across the digital section by the transmission of a quarter baud rate (27 kHz) wake-up tone.

In the NT1 to LT direction, the duration of this wake up tone shall not be less than 32 complete cycles of the repetitive data pattern +--+-. The tone shall not exceed 10 ms in duration.

In the LT to NT1 direction, the duration of the wake-up tone shall not be less than 32 complete cycles of the repetitive data pattern +--+-. The tone shall not exceed 10 ms in duration.

VI.10.2 Definition of internal timers

The activation procedure shall nominally take 120 ms to the point where error free framed transmission can commence.

In the event of the activation procedure failing, or loss of synchronisation on either the interface at the T-Reference point or on the transmission system described herein, a timer is required in the NT to terminate operation. This timer shall not exceed 65 ms measured from the point of loss of synchronisation; or in the case of activation, measured from the time at which synchronisation should be achieved.

It is not essential to employ a timer for the identification of failure to activate or loss of synchronisation signalled to the LT. However, where there is no external control of the de-activation procedure applied to the two wire LT termination, a timer not exceeding 65 ms from the time of loss of synchronisation or as measured from the time at which activation should have been achieved should be employed.

VI.10.3 Activation procedure

Table VI-2/G.961 shows the training sequence signals that should be transmitted to line by the LT and NT1. At the LT, offsets are measured in baud periods from the end of the wake-up tone transmission. At the NT1, offsets are measured in baud periods from the detection of the end of the wake-up tone. For correct operation, it is necessary that the time from the LT completing the wake-up tone burst, to the NT1 detecting the end of wake-up tone is less than or equal to 32 bauds.

TABLE VI-2/G.961

Activation training sequence

Offset (bauds)	Duration (bauds)	LT timing signal	LT data	NT timing signal	NT data
0	64	OFF	None	OFF	None
64	512	ON	None	OFF	None
576	512	OFF	None	ON	None
1 088	512	ON	None	OFF	None
1 600	512	OFF	None	ON	None
2 112	4096	ON	PRBS	OFF	None
6 208	32	ON	None	OFF	None
6 240	4064	ON	None	OFF	SBSA
10 304	(405) (Note 1)	ON	Ternary (Note 1)	OFF	None
10 709 (Note 1)	(405) (Note 2)	ON	Ternary (Note 2)	OFF	Ternary (Note 2)

PRBS stand for a 511 bit pseudo-random binary sequence generated by the polynomial $(1 \oplus x^{-4} \oplus x^{-9})$.

Note 1 – The transmission of ternary data from the LT to the NT1 from this time onwards in continuous. The NT1 will not return ternary data until it has achieved synchronisation, the figure of 405 bauds and the subsequent offset to the next row is intended as a guide to the normal duration for this process.

Note 2 – Ternary transmission from NT1 to LT implies that error-free transmission and frame synchronisation have been achieved in the NT. Following the LT acquiring synchronisation, full duplex 2B + D transmission can commence.

The conditional step between the NT1 acquiring synchronisation and returning ternary data is included to provide a mechanism by which the optional alignment of LT to NT1 and NT1 to LT frame words can be achieved.

VI.10.4 State transition table of the NT

See Table VI-3/G.961.

TABLE VI-3/G.961

State transition table of the NT

State		NT1 ready for act.	NT2 training	NT3 wait for T	NT4 wait for data valid	NT5 steady state	NT6 TE act.	NT7 pending deact.
Signal transmitted to TE		I0	I0	I2	I2	I4	I0	
Events								
Source	Event							
TL	Activate indication [FE1]	NT2	–	–	–	–	NT2	–
TR1	In synch. [FE3]	/	NT3	–	–	–	/	–
ET	INFO 3	/	/	NT4	–	–	/	–
TR1	Data valid	/	/	/	NT5	–	/	–
ET	Activate indication INFO 1	NT6	/	/	/	/	–	–
TR1	Loss of synch. [FE3]	–	NT7	NT7	NT7	NT7	–	–
TR1	No line sig. detect on DS	–	–	–	–	–	–	NT1

- No change
- / Impossible
- [] Remote source event
- DS Digital system

VI.10.5 State transition table of the LT

See Table VI-4/G.961.

TABLE VI-4/G.961

State transition table of the LT

State	LT1 Ready for act.	LT2 Training	LT3 Dig. sect. active	LT4 T-ref in synch.	LT5 Steady state		LT7 Pending deact.
Signal transmitted to DS	Inactive	Training seq.	Steady state	Steady state	Steady state		Inactive
Events							
Source Event							
ET FE1 (activate reqst.)	LT2	/	/	/	/		–
LT DS in-synch.	/	FE3 LT3	–	–	–		/
LT EF2 No line activity LSD → False	/	–	–	–	–		LT1
NT1 [INFO 3] Ready for data	/	/	FE4 LT4	–	–		/
LT DS loss of synchronisation	/	FE7 LT7	FE7 LT7	FE7 LT7	FE7 LT7		–
LT FE5 deactivation request	/	FE7 LT7	FE7 LT7	FE7 LT7	FE7 LT7		–
ET Data valid	/	/	/	LT5	–		–

- No change
- / Impossible
- [] Remote source event
- LSD Line signal detect

VI.10.6 Activation times

The “cold start” and “warm start” times will be 120 ms± 10 ms with all cable combinations permissible. This reliable and repeatable activation time is a result of the specific activation sequence specified in this SU32 standard.

VI.11 *Jitter*

Jitter performance must be sufficient for the purpose of providing the clock for interface at the T-reference point transmission function in accordance with Recommendation I.430.

The SU32 proposal features an orthogonal timing signal superimposed on the data. This leads to stable and low jitter digital phase locked loop timing circuitry being easily achieved.

VI.11.1 to VI.11.3

For further study.

VI.12 *Transmitter output characteristic of the NT or LT*

VI.12.1 *Pulse amplitude*

The nominal pulse amplitude shall be zero to peak 1.8 volts. The tolerance on this peak pulse amplitude shall be such that signal power and amplitude vs. frequency spectrum performance is as specified in § VI.12.

VI.12.2 *Pulse shape*

The pulse shape is determined by the pulse mask of Figure VI-3/G.961.

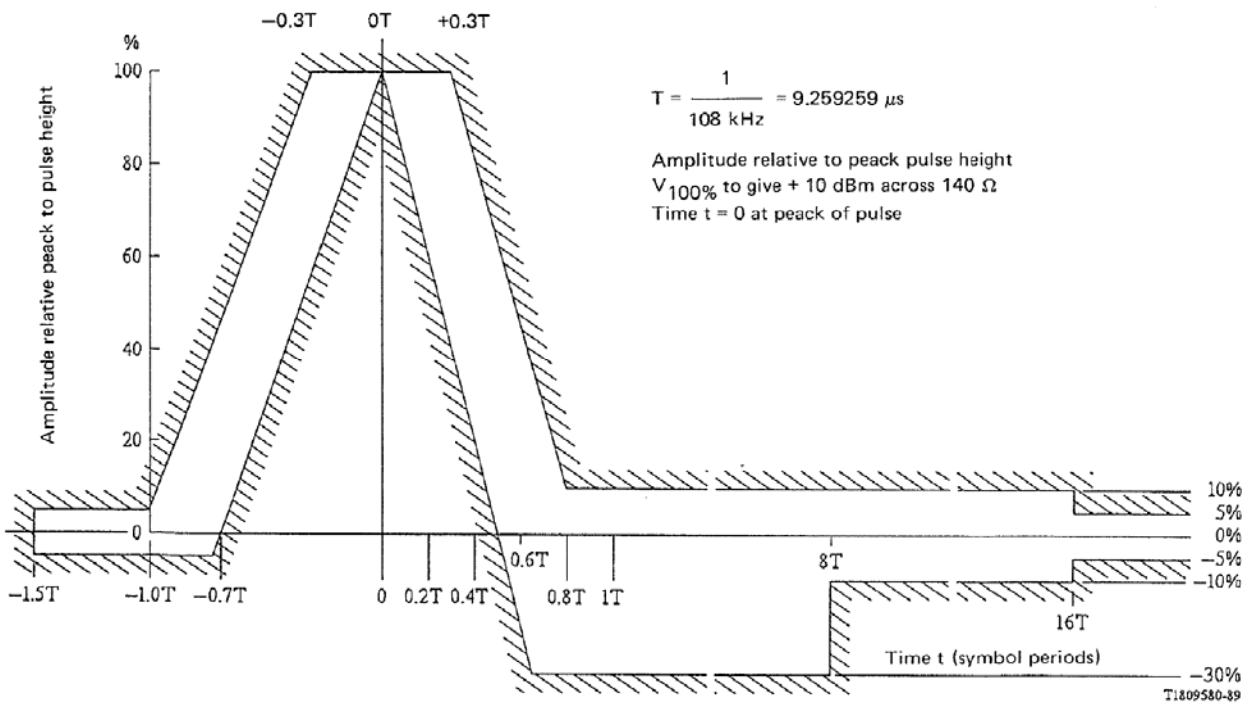

FIGURE VI-3/G.961

Single pulse mask – 108 kbauds transmitter pulse shaping

VI.12.4 *Power spectrum*

SU32 has a code spectrum modified by the conditional coding rule compared to random ternary signalling. The theoretical power spectrum when using SU32 having full width rectangular pulse shaping with transformer coupling is given in Figure VI-4/G.961.

Limits for the transmitted power spectral density are given in Figure VI-5/G.961.

Conditions: 10mW transmit power
 Transformer coupling assumed
 Full width rectangular pulses

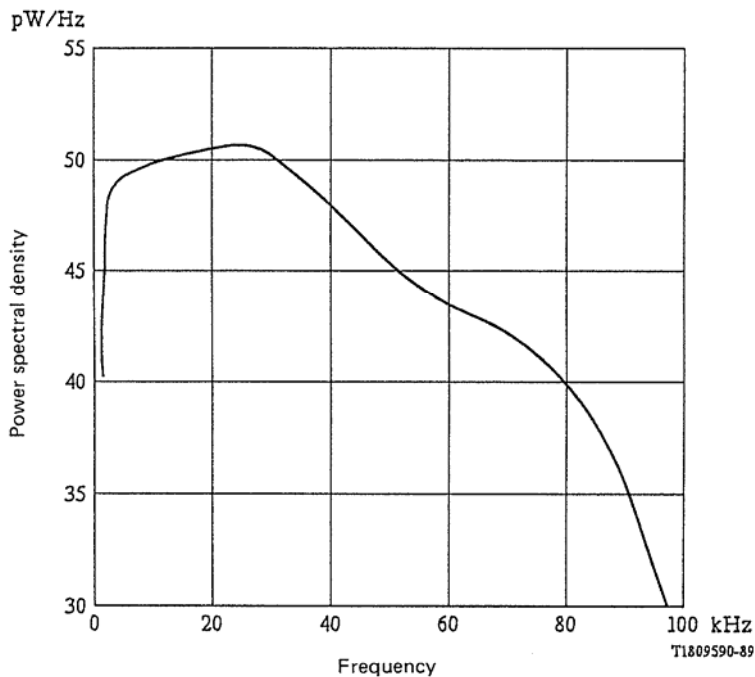

FIGURE VI-4/G.961

On line power spectral density of SU32 line code

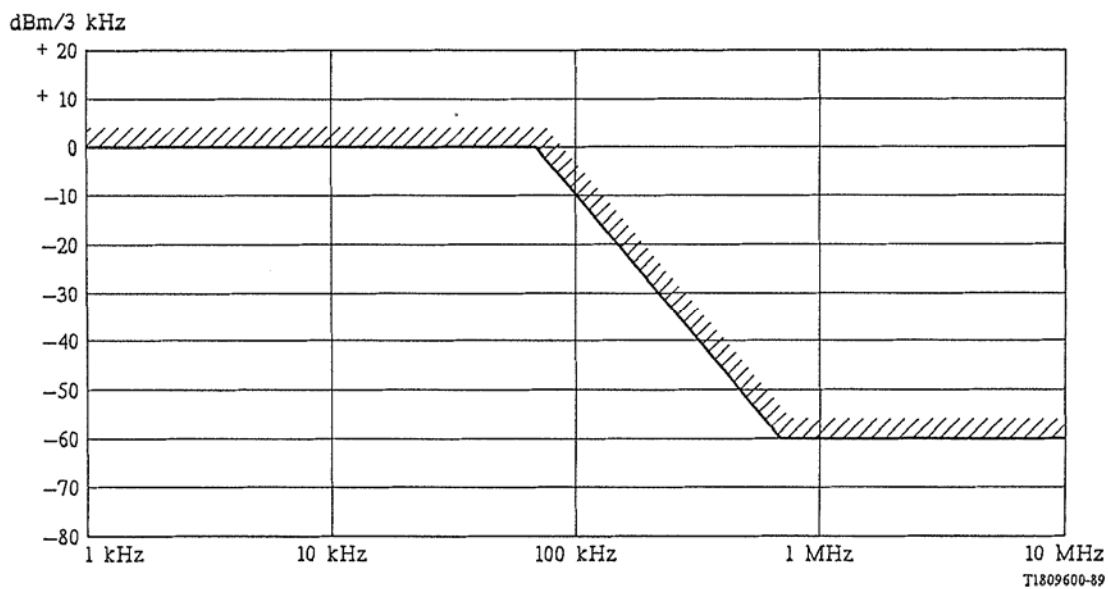

FIGURE VI-5/G.961

Transmitted power spectral density specification

Power levels

Signals sent to line must conform to the following criteria, under all operating conditions with 140 ohms resistive termination:

- a) The maximum total transmit power, averaged in any 1 second period must not exceed +11 dBm.
- b) The maximum transmit power average in any 1 second period in any 3 kHz band, below 100 kHz, must be less than 0 dBm. This limit extends down to DC (excluding power feed).
- c) The nominal recommended transmit power will be +9.5 dBm with a tolerance of ± 1 dB.

VI.13 *Transmitter/receiver termination*

VI.13.1 *Impedance*

The nominal output/input impedance looking towards the NT shall be 140 ohms. The nominal output/input impedance looking towards the LT shall be 140 ohms.

VI.13.2 *Return loss*

For further study.

VI.13.3 *Longitudinal conversion loss*

The longitudinal conversion loss in the range 100 Hz to 1.6 times the symbol rate (f_0) shall exceed 46 dB. For a frequency $10 \text{ MHz} > f > 1.6 f_0$, the longitudinal loss shall exceed $46 - 40 \log (f/1.6 f_0)$ dB or 24 dB whichever is greater.

ITU-T RECOMMENDATIONS SERIES

Series A	Organization of the work of the ITU-T
Series B	Means of expression: definitions, symbols, classification
Series C	General telecommunication statistics
Series D	General tariff principles
Series E	Overall network operation, telephone service, service operation and human factors
Series F	Non-telephone telecommunication services
Series G	Transmission systems and media, digital systems and networks
Series H	Audiovisual and multimedia systems
Series I	Integrated services digital network
Series J	Transmission of television, sound programme and other multimedia signals
Series K	Protection against interference
Series L	Construction, installation and protection of cables and other elements of outside plant
Series M	TMN and network maintenance: international transmission systems, telephone circuits, telegraphy, facsimile and leased circuits
Series N	Maintenance: international sound programme and television transmission circuits
Series O	Specifications of measuring equipment
Series P	Telephone transmission quality, telephone installations, local line networks
Series Q	Switching and signalling
Series R	Telegraph transmission
Series S	Telegraph services terminal equipment
Series T	Terminals for telematic services
Series U	Telegraph switching
Series V	Data communication over the telephone network
Series X	Data networks and open system communications
Series Y	Global information infrastructure and Internet protocol aspects
Series Z	Languages and general software aspects for telecommunication systems