

International Telecommunication Union

ITU-T

TELECOMMUNICATION
STANDARDIZATION SECTOR
OF ITU

G.971

(07/2010)

SERIES G: TRANSMISSION SYSTEMS AND MEDIA,
DIGITAL SYSTEMS AND NETWORKS

Digital sections and digital line system – Optical fibre
submarine cable systems

**General features of optical fibre submarine
cable systems**

Recommendation ITU-T G.971



ITU-T G-SERIES RECOMMENDATIONS
TRANSMISSION SYSTEMS AND MEDIA, DIGITAL SYSTEMS AND NETWORKS

INTERNATIONAL TELEPHONE CONNECTIONS AND CIRCUITS	G.100–G.199
GENERAL CHARACTERISTICS COMMON TO ALL ANALOGUE CARRIER-TRANSMISSION SYSTEMS	G.200–G.299
INDIVIDUAL CHARACTERISTICS OF INTERNATIONAL CARRIER TELEPHONE SYSTEMS ON METALLIC LINES	G.300–G.399
GENERAL CHARACTERISTICS OF INTERNATIONAL CARRIER TELEPHONE SYSTEMS ON RADIO-RELAY OR SATELLITE LINKS AND INTERCONNECTION WITH METALLIC LINES	G.400–G.449
COORDINATION OF RADIOTELEPHONY AND LINE TELEPHONY	G.450–G.499
TRANSMISSION MEDIA AND OPTICAL SYSTEMS CHARACTERISTICS	G.600–G.699
DIGITAL TERMINAL EQUIPMENTS	G.700–G.799
DIGITAL NETWORKS	G.800–G.899
DIGITAL SECTIONS AND DIGITAL LINE SYSTEM	G.900–G.999
General	G.900–G.909
Parameters for optical fibre cable systems	G.910–G.919
Digital sections at hierarchical bit rates based on a bit rate of 2048 kbit/s	G.920–G.929
Digital line transmission systems on cable at non-hierarchical bit rates	G.930–G.939
Digital line systems provided by FDM transmission bearers	G.940–G.949
Digital line systems	G.950–G.959
Digital section and digital transmission systems for customer access to ISDN	G.960–G.969
Optical fibre submarine cable systems	G.970–G.979
Optical line systems for local and access networks	G.980–G.989
Access networks	G.990–G.999
MULTIMEDIA QUALITY OF SERVICE AND PERFORMANCE – GENERIC AND USER-RELATED ASPECTS	G.1000–G.1999
TRANSMISSION MEDIA CHARACTERISTICS	G.6000–G.6999
DATA OVER TRANSPORT – GENERIC ASPECTS	G.7000–G.7999
PACKET OVER TRANSPORT ASPECTS	G.8000–G.8999
ACCESS NETWORKS	G.9000–G.9999

For further details, please refer to the list of ITU-T Recommendations.

Recommendation ITU-T G.971

General features of optical fibre submarine cable systems

Summary

Recommendation ITU-T G.971 applies to optical fibre submarine cable systems. The purpose of this Recommendation is to identify the main features of optical fibre submarine cable systems, and to provide generic information on relevant Recommendations in the field of optical fibre submarine cable systems. A common implementation relevant to all the optical fibre submarine cable systems is described in Annex A. Specific information relevant to each optical fibre submarine cable systems is included in annexes of other Recommendations. The updated data on cable ships and submersible equipment of various countries are also described in Appendix I.

History

Edition	Recommendation	Approval	Study Group
1.0	ITU-T G.971	1993-03-12	XV
2.0	ITU-T G.971	1996-11-11	15
3.0	ITU-T G.971	2000-04-04	15
4.0	ITU-T G.971	2004-06-13	15
5.0	ITU-T G.971	2007-07-29	15
6.0	ITU-T G.971	2010-07-29	15

FOREWORD

The International Telecommunication Union (ITU) is the United Nations specialized agency in the field of telecommunications, information and communication technologies (ICTs). The ITU Telecommunication Standardization Sector (ITU-T) is a permanent organ of ITU. ITU-T is responsible for studying technical, operating and tariff questions and issuing Recommendations on them with a view to standardizing telecommunications on a worldwide basis.

The World Telecommunication Standardization Assembly (WTSA), which meets every four years, establishes the topics for study by the ITU-T study groups which, in turn, produce Recommendations on these topics.

The approval of ITU-T Recommendations is covered by the procedure laid down in WTSA Resolution 1.

In some areas of information technology which fall within ITU-T's purview, the necessary standards are prepared on a collaborative basis with ISO and IEC.

NOTE

In this Recommendation, the expression "Administration" is used for conciseness to indicate both a telecommunication administration and a recognized operating agency.

Compliance with this Recommendation is voluntary. However, the Recommendation may contain certain mandatory provisions (to ensure, e.g., interoperability or applicability) and compliance with the Recommendation is achieved when all of these mandatory provisions are met. The words "shall" or some other obligatory language such as "must" and the negative equivalents are used to express requirements. The use of such words does not suggest that compliance with the Recommendation is required of any party.

INTELLECTUAL PROPERTY RIGHTS

ITU draws attention to the possibility that the practice or implementation of this Recommendation may involve the use of a claimed Intellectual Property Right. ITU takes no position concerning the evidence, validity or applicability of claimed Intellectual Property Rights, whether asserted by ITU members or others outside of the Recommendation development process.

As of the date of approval of this Recommendation, ITU had not received notice of intellectual property, protected by patents, which may be required to implement this Recommendation. However, implementers are cautioned that this may not represent the latest information and are therefore strongly urged to consult the TSB patent database at <http://www.itu.int/ITU-T/ipr/>.

© ITU 2010

All rights reserved. No part of this publication may be reproduced, by any means whatsoever, without the prior written permission of ITU.

CONTENTS

	Page
1 Scope	1
2 References.....	1
3 Definitions	1
3.1 Terms defined elsewhere.....	1
4 Abbreviations and acronyms	1
5 Conventions	2
6 Features of optical fibre submarine cable systems	2
7 Relationship among Recommendations relevant to optical submarine cable systems.....	3
Annex A – Common implementation aspects of optical submarine cable systems for manufacturing, installing and maintenance	5
A.1 Introduction	5
A.2 Manufacturing	5
A.3 System installation.....	6
A.4 System commissioning.....	7
A.5 Maintenance	7
Appendix I – Data on cable ships and submersible equipments of various countries	9
I.1 Cable ships.....	9
I.2 Submersible equipments.....	14
Bibliography.....	21

Recommendation ITU-T G.971

General features of optical fibre submarine cable systems

1 Scope

This Recommendation applies to optical fibre submarine cable systems.

The purpose of this Recommendation is to identify the main features of optical fibre submarine cable systems, and to provide generic information on relevant Recommendations in the field of optical fibre submarine cable systems. Annex A contains common implementation aspects of all optical submarine cable systems. Appendix I contains data on cable ships and submersible equipments of various countries.

2 References

The following ITU-T Recommendations and other references contain provisions which, through reference in this text, constitute provisions of this Recommendation. At the time of publication, the editions indicated were valid. All Recommendations and other references are subject to revision; users of this Recommendation are therefore encouraged to investigate the possibility of applying the most recent edition of the Recommendations and other references listed below. A list of the currently valid ITU-T Recommendations is regularly published. The reference to a document within this Recommendation does not give it, as a stand-alone document, the status of a Recommendation.

- [ITU-T G.821] Recommendation ITU-T G.821 (2002), *Error performance of an international digital connection operating at a bit rate below the primary rate and forming part of an Integrated Services Digital Network.*
- [ITU-T G.972] Recommendation ITU-T G.972 (2004), *Definition of terms relevant to optical fibre submarine cable systems.*
- [ITU-T G.973] Recommendation ITU-T G.973 (2007), *Characteristics of repeaterless optical fibre submarine cable systems.*
- [ITU-T G.973.1] Recommendation ITU-T G.973.1 (2009), *Longitudinally compatible DWDM applications for repeaterless optical fibre submarine cable systems.*
- [ITU-T G.974] Recommendation ITU-T G.974 (2007), *Characteristics of regenerative optical fibre submarine cable systems.*

3 Definitions

3.1 Terms defined elsewhere

This Recommendation uses the terms defined in [ITU-T G.972].

4 Abbreviations and acronyms

This Recommendation uses the following abbreviations and acronyms:

BAS	Burial Assessment Survey
BOL	Beginning of Life
BU	Branching Unit
CPT	Cone Penetrometer Testing
CTE	Cable Terminating Equipment

DP-system	Dynamic Positioning-system
DWDM	Dense Wavelength Division Multiplexing
PFE	Power Feeding Equipment
PLGR	Pre-Lay Grapnel Run
ROV	Remotely Operated Vehicle
SCARAB	Submersible Craft Assisting Repair and Burial
SWL	Safe Working Load
TSE	Terminal Station Equipment
TTE	Terminal Transmission Equipment

5 Conventions

This clause is intentionally left blank.

6 Features of optical fibre submarine cable systems

An optical fibre submarine cable system has specific technical features:

- a) A submarine cable system should achieve a long lifetime and a high reliability; the main reason is that, due to the difficulty in accessing the submerged plant, the construction and maintenance of a link is long and expensive; moreover, most of submarine links are of strategic importance in the transmission network and the interruption of a link usually results in significant loss of traffic and revenue.
- b) A submarine cable system should possess mechanical characteristics which enable it:
 - 1) to be installed accurately with correct slack and with due safety consideration on the seabed; deep water installations may reach 8000 metres. (In general, submarine cable systems shall be installed, buried or inspected by specially designed cable ships and submerged equipments. Detailed information of such cable ships and submerged equipments (i.e., ploughs, ROVs, etc.) is contained in Appendix I);
 - 2) to resist the sea bottom environment condition at the installation depth, and particularly hydrostatic pressure, temperature, abrasion, corrosion, and marine life;
 - 3) to be adequately protected (i.e., by armouring or burying) against aggression, due for example to trawlers or anchors;
 - 4) to survive recovery from such a depth, and subsequent repair and relay, with due safety consideration.
- c) The material characteristics of a submarine cable system should enable the optical fibre:
 - 1) to achieve its desired reliability over its design lifetime;
 - 2) to tolerate stated loss and aging mechanisms, especially bending, strain, hydrogen, stress, corrosion and radiation.
- d) The transmission quality of a submarine cable system should follow as a minimum [ITU-T G.821].

Figure 1 shows the basic concept of optical fibre submarine cable systems and boundaries. Optical submarine repeaters or optical submarine branching units could be included, depending on each system requirement.

In Figure 1, "A" denotes the system interfaces at the terminal station (where the system can be interfaced to terrestrial digital links or to other submarine cable systems), and "B" denotes beach joints or landing points. Numbers in brackets in the figure refer to [ITU-T G.972].

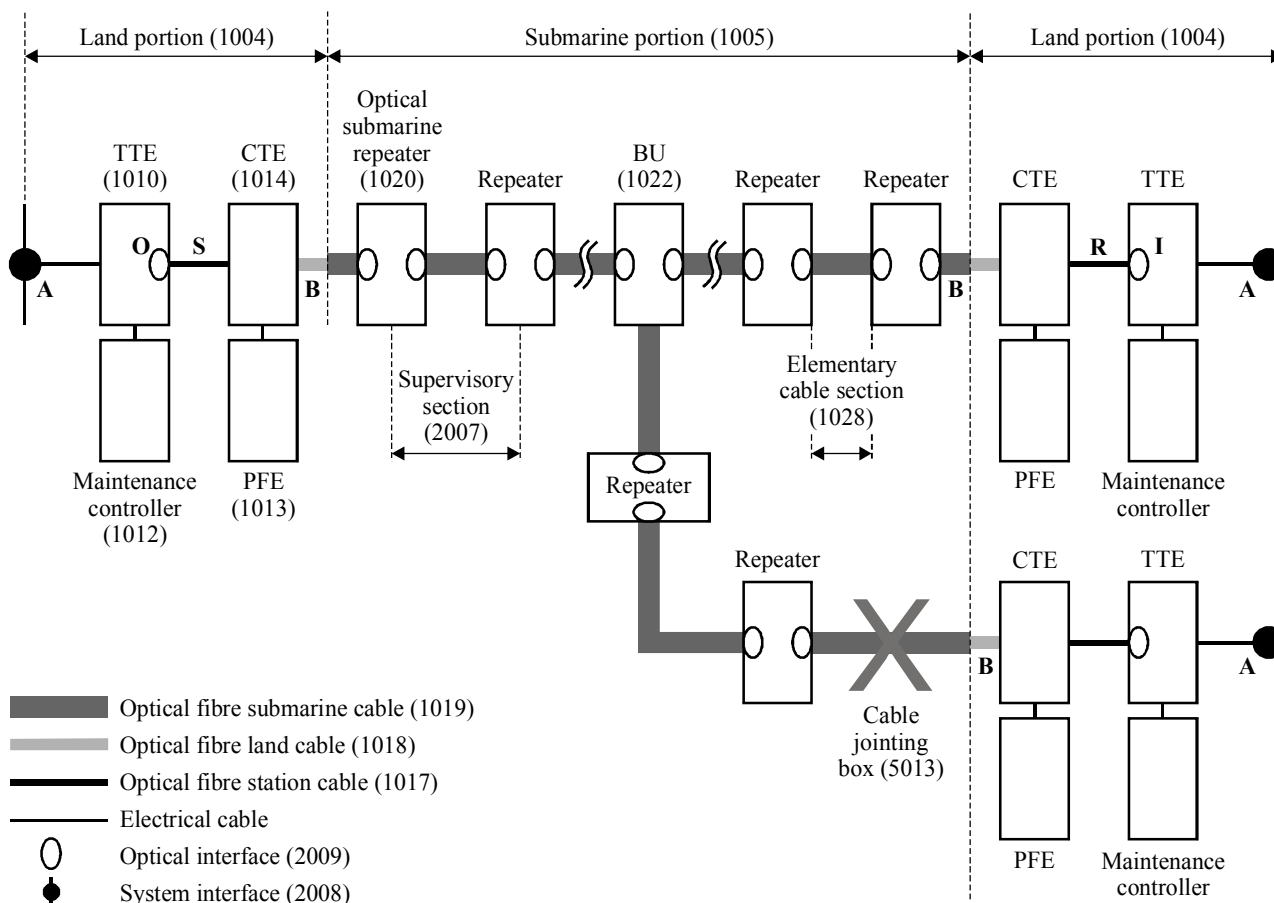

NOTE 1 – A denotes system interface.
 NOTE 2 – B denotes landing points or beach joints (1006).
 NOTE 3 – X denotes cable jointing box (5013).
 NOTE 4 – Number in brackets relate to [ITU-T G.972].

G.971(10)_F01

Figure 1 – Example of optical fibre submarine cable systems

7 Relationship among Recommendations relevant to optical submarine cable systems

Relationships among the various Recommendations pertaining to optical fibre submarine cable systems are shown in the flow chart presented in Figure 2.

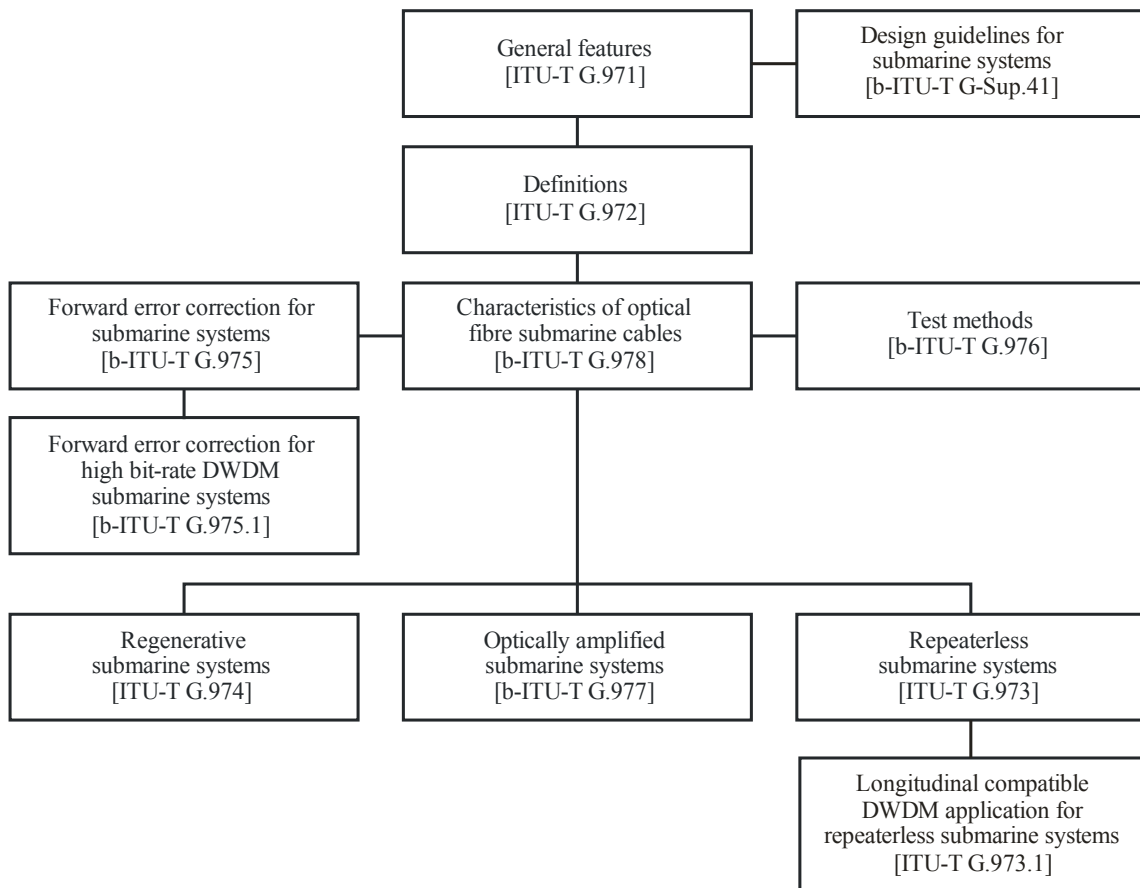

G.971(10)_F02

Figure 2 – Relationships amongst Recommendations relevant to optical submarine cable systems

Annex A

Common implementation aspects of optical submarine cable systems for manufacturing, installing and maintenance

(This annex forms an integral part of this Recommendation)

A.1 Introduction

This annex outlines the common aspects of submarine cable systems, which are specified in [ITU-T G.973], [ITU-T G.973.1], [ITU-T G.974] and [ITU-T G.977], such as manufacturing, installation, and maintenance.

The information provided in this annex is intended as a guide to current practice and is not intended as a Recommendation relating to existing or future systems.

A.2 Manufacturing

A.2.1 Quality in optical fibre submarine cable systems

The high performance and reliability requirement established for an optical fibre submarine cable system can be fulfilled only if stringent quality procedures are applied during designing, manufacturing, and laying of a system. Although quality procedures are particular to each optical fibre submarine cable supplier, the following basic principles generally apply.

A.2.1.1 Qualification of the designs and technologies

This activity, part of the development process, is intended to demonstrate that the performance of a technology, a component or an assembly is compatible with meeting the overall system performance requirements and provides reasonable assurance that the reliability target can be met. Qualification includes high-stress testing, intended to estimate the ruggedness of the technology, component or subassembly and to determine the screening procedure, and long-term life testing (some of which might be accelerated for instance by the temperature), the purpose of which is to confirm the validity of the screening procedure and to evaluate the lifetime and/or the reliability of the technology, component or assembly. Qualification of a cable or submarine equipment may also include sea trials.

A.2.1.2 Certification of components and sub-assemblies

This activity, part of the manufacturing process, is intended to assure the ability of each component or assembly to comply with its performance and reliability specifications once installed. For submarine equipment, each component is individually certified.

The certification is based on the results of screening tests, intended to remove any unsatisfactory item or component, and particularly those likely to exhibit early failures.

A.2.1.3 Manufacturing inspection

This activity, during the manufacturing process, is intended to verify that the quality plan is respected, that each operation is accomplished according to the agreed procedure, and that the result is satisfactory.

The responsibility for manufacturing inspection can be shared between the manufacturer and the purchaser of an optical fibre submarine cable system.

A.2.1.4 Factory acceptance tests

After completion of the manufacture of each item (TSE and submerged equipment), functional and performance tests must be carried out in order to release the equipment from the factory.

This activity, conducted in the factory, should comprise all tests necessary to confirm that TSE (including final software) and submerged equipment (repeater and cable sections) are ready for installation or assembly. The tests should demonstrate that the requirements of the technical specification will be met by the segments and the full network once installed or assembled if no discrepancy occurs during the installation or assembly period.

On completion of factory testing, equipment may be tested during a confidence trial period to check its stability.

A.2.2 Assembly and loading procedure

Link assembly consists of jointing the cable sections, the repeaters and the branching units, together with monitoring that the guaranteed margin is present for each fibre in each cable section, so as to constitute the submarine portion. Link assembly is usually performed in the cable factory prior to loading.

Ship loading consists of installing the submarine portion, or fractions of it, on board the cable ship, prior to laying. Ship loading is generally performed with the link unpowered. Tests are made periodically during loading to confirm that the performance of the assembled equipment has not been affected by the loading process.

A.3 System installation

A.3.1 Submarine route survey

A route survey is performed prior to cable laying so as to select the cable route and means of cable protection (lightweight protection, armour, burial). The route survey consists of studying the sea depth profile, the sea bottom temperature and seasonal variations, the morphology and nature of the sea bottom, the position of existing cables and pipes, the cable fault history, fishing and mining activities, sea current, seismic activity, laws, etc.

A cable route study should normally be carried out prior to the start of a route survey to determine all environmental, political, economical and practical aspects related to the route. Discussions should be held with local authorities and fishing bodies for this purpose, together with the inspection of landing sites and access points, as necessary.

An assessment of burial feasibility can also be carried out as part of the route survey, either through direct continuous measurement (burial assessment survey (BAS)) or discrete periodic measurement (cone penetrometer testing (CPT)).

A.3.2 Submarine cable installation

Cable laying is normally performed using a recognized cable-ship after any necessary route clearance in shallow water has been carried out (e.g., pre-lay grapnel run (PLGR)).

Laying is normally undertaken only when weather and sea conditions do not create severe risk of damage to the submarine portion, cable ship and laying equipment, or of injury to the personnel.

The cable may be buried in the seabed to increase cable protection. Burial can be undertaken during laying using a sea plow towed by the laying cable ship, or after laying using a self-propelled submersible robot or other means.

During laying, a predetermined cable overlength (slack) is laid, so as to ensure that the cable is properly laid on the sea bottom.

The system should be tested during the laying and at the end of laying, so as to ensure that no significant system degradation has been induced. Laying testing includes transmission and functional tests, and may include tests on redundant subassemblies. To permit testing during cable laying, the link may be powered, provided that safety regulations are respected.

A.3.3 Land cable installation and testing

Land cable tests will be performed after the completion of land cable installation at each site to confirm performances.

Especially, the return earth system shall be tested after its installation.

A.3.4 Terminal station equipment installation and testing

After completion of terminal station equipment installation activities in the cable terminal station, a site acceptance testing programme should be conducted based on the factory acceptance test programme already performed. Results of both periods should be compared. In the event of an unfavourable comparison between the two sets of results, the cause of the irregularities should be determined.

All equipment units provided as spares shall be tested for correct operation by substitution with working units.

On completion of the suite tests, the equipment shall be subject to a continuous confidence trial period to be defined depending of the equipment type.

Following the site acceptance testing period for each item, interconnection of equipment should be carried out to control their interoperability. A specific integration test plan should then be conducted. The results obtained could be compared with previous results (including technology demonstration). In the event of an unfavourable comparison between the two sets of results, the cause of the irregularities should be determined.

A.4 System commissioning

Commissioning testing is performed prior to installing traffic on the system to ensure that the system meets its overall transmission performance contractual requirement, and that all functionalities with respect to the network management are operating. When extra margins are available at the beginning of life (BOL), it is recommended that they be assessed in order to track the ageing of the system.

If redundancy is used in the design to meet the reliability performance, redundant components could be used for correcting faults occurring during laying or prior to commissioning. However, the objective is to ensure that the number of redundant devices remaining available is sufficient to meet, with a high probability, the target for the number of ship repairs.

On completion of the system commissioning period, a continuous transmission segment out of service confidence trial should be followed. Carefully controlled procedures should be established to prevent the introduction of errors through human action. Any irregularity, variation alarm or non-routine event observed should be investigated.

A.5 Maintenance

A.5.1 Routine maintenance

Routine maintenance is performed from the terminal stations using the supervisory system. It consists of periodic monitoring of the system parameters and, when required, in preventive redundancy switching.

A.5.2 Maintenance at sea

Optical fibre submarine cable systems can be subject to faults due, in particular, to external aggression and to component failure. It is important to define and develop well-established and efficient repair procedures and equipment, to facilitate repair and limit loss of traffic.

Maintenance at sea is usually performed using dedicated repair cable ships.

A.5.2.1 Fault localization

For systems equipped with optical submarine repeaters, a first localization to within one supervisory section is obtained using the supervisory system.

For the end cable sections, cable fault localization may be achieved from the terminal stations, using adequate electrical measurement (resistance, capacitance, insulation, etc.) and optical reflectometry.

Similarly, cable fault localization may be achieved from the cable ship after cable recovery, using the same methods.

Electroding can be used to locate the cable route.

A.5.2.2 Cable recovery

During cable recovery, it may be necessary, in order to limit the mechanical tension applied to the cable, to cut the cable on the sea bottom prior to recovering both ends separately.

A.5.2.3 Sea repair

Several methods can be used for sea repair according to the sea depth:

- the shallow water repair may necessitate the addition of a cable length, but not that of a repeater; a repair margin is generally included in the shallow water optical power budget since the shallow water sections are the most exposed to risk from external aggression, even though precautions are taken;
- the deep sea repair usually necessitates the addition of a cable length and sometimes of a repeater to compensate for the extra attenuation, if the extra attenuation incurred cannot be accommodated in the available margin; generally, a very low repair margin is included in the deep water optical power budget since deep sea repairs are not frequent.

When a fault is identified to within one supervisory section, the section may be replaced by a mini-system, without further localization. This method may save time, but requires more spare equipment.

Repair safety procedures are applied on board the cable ship and in the terminal station, so as to ensure the safety of the personnel operating on board the cable ship. In particular, power safety procedures involve earthing the cable in the terminal station, on board the cable ship and at the branching unit.

Appendix I

Data on cable ships and submersible equipments of various countries

(This appendix does not form an integral part of this Recommendation)

I.1 Cable ships

Cable ships are utilized not only for laying optical submarine cable but also for repairing optical submarine cable, including repeaters. A cable ship contains a cable tank, a cable engine, and an unwinding/winding pulley. The cable tank houses wound optical submarine cable and repeaters. The cable engine controls the unwinding/winding speed so that it synchronizes well with the ship speed. Unwinding/winding pulleys are installed at the bow and/or stern of the ship, and are called bow and stern sheaves, respectively.

The cable ship also carries submersible equipment for underwater work. Generally, a dynamic positioning (DP) system is used, and it maintains the position of the ship at a fixed point automatically without the use of an anchor.

Name of ship	Year of construction	Displacement (tons)	Overall length (m)	Draft (m)	Normal speed (knots)	Range (autonomy) (nautical miles)	Number of tanks	Cable capacity		Cable gear				Max operating depth (m)	Capability	
								Cable		Re-peaters	Cable engine		Unwinding pulley			
								Cubic metres (m ³)	Weight (tons)		Drum (diameter) (m)	Linear (pairs of wheels)	Bow sheave (diameter) (m)			Stern sheave (diameter) (m)
Peter Faber	1982	3680	78.35	Ice 3.8 Summer 5.0	13.0	7000	1 tank	310	600	App. 10	3.0		2 × 3.0	–	4000	Reinforced for operation in ice-filled waters. A-frame for ROV. Two hydraulic double-drum warping winches.
Lodbrog	1985/ 2002	12'503	143.4	8.50	16.0	10'000	1 hold 6	230 2940	400 5040	84	2 × 4.0 (25 t)	2 × 6 (6 t)	–	2 × 3.0	All	Laying/burying and repair of all types of cables (coaxial, optical fibre and power cables). ROV capability, SWL 8 ton.
M/S Telepaatti	1978 (modification)	450	42.6	3.0	12	–	1	–	350	–	2 linear engines with 3 caterpillar tracks on each	3.0		300		Laying of all types of telecom cables. Specially equipped for cable route survey and cable repair. Fully automatic autopilot and DP-system.
c/s Telepaatti	1978 Modification 1999	450	42.6	3.0	10.5	–	1	250	260	–	–	2 linear engines with 3 caterpillar tracks on each	3.0	–	300	Laying of all types of telecom cables and < 150 mm power cables. Specially equipped for cable route survey and cable repair. Fully automatic autopilot and DP-system.
Chamarel (formerly Vercors)	1974	11'000	136	7.2	16.0	12'000	3	2425	4900	144	3.0	24	3.0	Chute	All	Laying and repair of all types of telecom cables. Burying of cables with plough and 200 kW Hector 4.
Léon Thevenin	1983	6800	107	6.24	15.0	10'000	2 + 1	1420	2000	11	3.4	12	3.0	Chute	All	Laying and repair of all types of telecom cables. Burying of cables using 300 kW Hector 5.

Name of ship	Year of construction	Displacement (tons)	Overall length (m)	Draft (m)	Normal speed (knots)	Range (autonomy) (nautical miles)	Number of tanks	Cable capacity			Cable gear				Max operating depth (m)	Capability					
								Cable		Re-peaters	Cable engine		Unwinding pulley								
								Cubic metres (m ³)	Weight (tons)		Drum (diameter) (m)	Linear (pairs of wheels)	Bow sheave (diameter) (m)	Stern sheave (diameter) (m)							
<i>Raymond Croze</i>	1983	6800	107	6.24	15.0	10'000	2 + 1	1420	2000	11	3.4	12	3.0	Chute	All	Laying and repair of all types of telecom cables. Burying of cables using 250 kW Hector 3.					
<i>René Descartes</i>	2002	15'450	114.50	7.42	16.0	12'000	4	3250	5500	210	4.0	20	Aft sheave 3.0 m	Sheave	All	Stem concept cable ship. Laying and repair of all types of telecom cables. Burying of cables with plough and 250 kW ROV Hector 6.					
<i>Ile de Sein</i> <i>Ile de Batz</i> <i>Ile de Brehat</i> <i>Ile de Ré</i>	2002 1983 rebuilt 2002	18'006 12'687	140.4 143.4	8.016 7.23	15.0 16.0	15'000 11'000	2 + 2 3 + 3	2) Ships belonging to Alda Marine			3000 2900	5500 4500	202 84	4.0 2 × 4.0	21 NA	NA NA	3.0 3.0	All All	Laying and repair of all types of telecom cables. Burying of cables with. 2/3m Rock plough. Sea state 7 A-frame Laying and repair of types of cable. ROV to 2500 m. A plough is available.		
<i>Teliri</i> <i>Certamen (ex John Cabot)</i>	1996 1966 rebuilt 1998	6500 5000	111.5 96.6	6.5 7.3	14.01 12.0	10'000 8000	3 3	ITALY 1) Ships belonging to Elettra TLC S.p.A					2000 600	2600 1900	70 24	2 × 3.5 1 × 3.0	18 18 (on the stern) + 6 (on the bow)	3 3	4 3	All All	Laying and repair optical fibre systems. Laying, survey and repair optical fibre systems.
<i>Giulio Verne</i>	1984	16'900	133.18	8.5	10	7000	2	ITALY 2) Ships belonging to Prysmian Cavi e Sistemi Energia S.r.l.					2600	7000	10	6.0 (55 t)	1 (Pads type 10 t)	–	6.0	All	Lay and repair from the stern.
<i>Teneo</i>	1992	4000	81	5.7	14.5	4200	2	SPAIN Ships belonging to Tyco Submarine Systems Ltd.					500	1000	20	2 × 3.5	1 × 9	2 × 3	1 × 3	All	Lays and repairs of all types of telephone cables.

Name of ship	Year of construction	Displacement (tons)	Overall length (m)	Draft (m)	Normal speed (knots)	Range (autonomy) (nautical miles)	Number of tanks	Cable capacity			Cable gear				Max operating depth (m)	Capability
								Cable		Re-peaters	Cable engine		Unwinding pulley			
								Cubic metres (m ³)	Weight (tons)		Drum (diameter) (m)	Linear (pairs of wheels)	Bow sheave (diameter) (m)	Stern sheave (diameter) (m)		
JAPAN																
<i>1) Ships belonging to Kokusai Cable Ship (KCS)</i>																
<i>KDDI Ocean Link</i>	1992	11'700	133.2	7.0	15	10'000	Main 3 Spare 4	2600	4500	57	3.6	21	3.2	4.0	All	Laying by linear engine. Lays and repairs all types of submarine cables.
<i>KDDI Pacific Link</i>	1997	11'207	109.0	7.5	11	10'000	Main 2 Spare 2	2720	4500	50	3.6	20	–	3.0	All	Laying by linear engine. Lays and repairs all types of submarine cables.
<i>2) Ships belonging to NTT World Engineering Marine Corporation (NTT-WE Marine)</i>																
<i>Subaru</i>	1999	9557	123.3	7.0	13.2	8800	Main 2 Spare 2	2770	4000	50	4.0	21	–	3.2	All	Lays and repairs all types of telephone cables.
<i>C/S VEGA</i>	1984	2293	74.3	4.5	13.0	4500	2	169	250	–	3.0	6	2.5	2.0	All	Lays and repairs for non-powered telephone cable system. DP, ROV system
UNITED KINGDOM																
<i>1) Ships belonging to British Telecommunications plc</i>																
<i>Sovereign</i>	1991	13'018	131	7.0	13.5	14'000	4	2800	6200	90	3.50		3.00	3.50	All	Lays, repairs all types of coaxial and optical fibre cable. (Operated by C&W marine.)
<i>2) Ships belonging to Global Marine Systems Ltd</i>																
<i>MV Cable Installer</i>	1980	6065	89.42	5	12	42 days	4	840	1600	None	3.0	4-track pair	–	3.0	–	Ditto (no plough). Repeaterless installation vessel fully DP Cegelec 901 system.
<i>Seaspread</i>	1980	10'887	116	6.8	13	65 days	2	1010	1701	–	2 × 3	–	–	3	All	Lays/repairs by aft drums. Burial by plough. Lays/repairs armoured and lightweight cables.
<i>Pacific Guardian</i>	1984	7526	116	6.32	14.0	8000	3	1416	3470	96	3.5		3.00	3.00	All	Laying by linear cable engine. Lays and repairs armoured and lightweight cables.
<i>Sir Elic Sharp</i>	1988	7526	115	6.3	13.5	9600	3	1416	1700	96	2 × 3.5	–	3	3	All	Laying by linear cable engine. Repairs and lays armoured and lightweight cables. Post lay/repair burial by integral ROV.

Name of ship	Year of construction	Displacement (tons)	Overall length (m)	Draft (m)	Normal speed (knots)	Range (autonomy) (nautical miles)	Number of tanks	Cable capacity			Cable gear				Max operating depth (m)	Capability
								Cable		Re-peaters	Cable engine		Unwinding pulley			
								Cubic metres (m ³)	Weight (tons)		Drum (diameter) (m)	Linear (pairs of wheels)	Bow sheave (diameter) (m)	Stern sheave (diameter) (m)		
<i>MV Cable Innovator</i>	1995	–	142	8.3	14.5	42 days	4	4900	7500	180	4.0	21 pairs (min)	–	4.0	–	Simplex D/P system. Lays/repairs cables.
<i>CS Coastal Connector</i>	1997 Converted in 1996	6761	92.47	7.1	12.5	25'000	3 main 1 spare	675 (main, total) 70 (spare)	1600	30	2 × 3	N/A	N/A	2 × 3	–	The CS Coastal Connector is a stern-laying design. She is capable of deploying the SCARAB II, SCARAB IV, and Pacific SCARAB I ROVs, as well as the Seabed Tractor.
<i>CS Tyco Provider</i>	1978, Converted in 1999	14'500	139.4	7.6	14.5	20'000	5	3349	6000	100+	2 × 4	–	–	2 × 3	–	The CS Tyco Provider is a stern-laying design. She is capable of deploying Sea Plow VIII.
<i>CS NIWA (ex. CS Global Link)</i>	1990	16'375	145.7	8.08	15	10'000	3 main, 4 spare	3258 (main, total) 164 (spare, total)	6098	100+	2 × 3.7	1 × Western Gear Tractor Type	2 × 3	1 × trough/Chute type	–	The CS NIWA is capable of deploying the SCARAB II ROVs.
<i>Gulmar Badaro (ex. CS Global Mariner)</i>	1993	15'638	151.5	7.8	13.8	10'000	2 main, 3 spare	2172 (main, total) 447 (spare, total)	4999	80+	2 × 3.7	1 × Dowty 21 pairs	2 × 3	1 × trough/Chute type	–	The Gulmar Badaro is capable of deploying the SCARAB II and SCARAB IV ROVs, as well as Sea Plow VII, Sea Plow VIII, and the Seabed Tractor.
<i>CS Global Sentinel</i>	1991	16'375	145.7	8.08	15	10'000	3 main, 4 spare	3258 (main, total) 164 (spare, total)	6098	100+	2 × 3.7	1 × Dowty 21 pairs	2 × 3	1 × trough/Chute type	–	The Global Sentinel is capable of deploying the SCARAB II and SCARAB IV, and Pacific SCARAB I ROVs, as well as Sea Plow VII and Sea Plow VIII.

Name of ship	Year of construction	Displacement (tons)	Overall length (m)	Draft (m)	Normal speed (knots)	Range (autonomy) (nautical miles)	Number of tanks	Cable capacity			Cable gear				Max operating depth (m)	Capability
								Cable		Re-peaters	Cable engine		Unwinding pulley			
								Cubic metres (m ³)	Weight (tons)		Drum (diameter) (m)	Linear (pairs of wheels)	Bow sheave (diameter) (m)	Stern sheave (diameter) (m)		
NOTE – Only relatively short cables are laid and only shore-end.																
UNITED ARAB EMIRATES <i>Ships belonging to E-marine PJSC</i>																
<i>CS Etisalat</i>	1990	2221	74.7	4.5	13	35 days	3	667	600	12	3	6	3	4	Unlimited	Surface lay, maintenance, ROV inspection and jet burial.
<i>CS NIWA</i>	1990	16'375	145.66	8.08	15	60 days	3 main 4 spare	3258	6098	152	4	18	4	4	Unlimited	Surface lay, plough burial, maintenance, work class ROV inspection and jet burial.
<i>CS UAA</i>	1972 Converted in 1996	7800	133.7	6.15	13	48 days	3 main 1 spare	3360	4500	120	4	18	4	4	Unlimited	Surface lay, plough, maintenance, work class ROV inspection and jet burial.
REPUBLIC OF KOREA <i>Ships belonging to KT Submarine</i>																
<i>SEGERO</i>	1998	8323	115	7.8	12		4	4500	2218	70ea	2 × 4	2 × 4	–	3.6		

I.2 Submersible equipments

Various types of submersible equipment are used to support the installation and maintenance of an optical submarine cable system. Typical examples of submersible equipment include a plough and a remotely operated vehicle (ROV).

A plow is towed by a cable ship and is used for laying the optical submarine cable while burying it.

An ROV is used when a plough is not available. A submersible craft assisting repair and burial (SCARAB) is a type of ROV. ROVs typically enable inspection, repair, and burial.

Type of submersible	Weight (tons)	Overall length (m)	Width (m)	Height (m)	Trenching system	Trenching	Propulsion	Max operating depth (m)	Max pulling tension (tons)	Capability
FRANCE										
<i>Submersibles belonging to France Telecom Marine</i>										
<i>ELISE2 Submersible Plough system</i>	17	7.60	2.90	2.95	Ploughshare	Immediate burial up to 1.1 m	Towed by support ship	1500		Lay and bury all types of cables.
<i>ELISE3 Submersible Plough system</i>	17	7.60	2.90	2.95	Ploughshare	Immediate burial up to 1.1 m	Towed by support ship	1500		Lay and bury all types of cables.
<i>Self-advancing buried system CASTOR2</i>	12	7.0	2.40	3.00	Trenching wheel or chain	Burial of existing cables down to 2 m	Tracked vehicle	1000		Burial of cables and pipes. Visual inspection.
<i>ROVs HECTOR 3, 4, 5 & 6</i>	9	4.0	3.50	2.10	High-pressure water jets	Up to 1.5 m depth	Thrusters (inspection) Back drive (burial)	2000		Visual inspection, post-lay burial, cable location, cable manipulation, cable cutting.
FRANCE										
<i>Submersibles belonging to France Telecom Marine</i>										
<i>Remote control submersible Scorpio 2000</i>	3.4	2.9	1.5	2.11	High-pressure water jets	Up to 60 cm depth	Thrusters	1000		Visual inspection, post-lay burial, cable location/manipulation/cutting.
ITALY										
<i>1) Submersibles belonging to Elettra TLC SpA</i>										
<i>Plough Taurus 1</i>	14	9	4.6	4.5	Plough share	Up to 1 m	Towed by cable ship	1500	50	Lay and bury all types of cables.
<i>Plough Taurus 2</i>	16	9.5	4.5	5.1	Plough share	Up to 1.5 m	Towed by cable ship	1500	50	Lay and bury all types of cables.
<i>ROV – Phoenix 2</i>	6.8	4.8	2	2.6	High/low-pressure jetting	Up to 1.2 m	8 Hydraulic thrusters	1000		Visual inspection, post-lay burial, cable location/manipulation/cutting.
<i>ROV-T200</i>	Free-fly mode 6, Track mode 7	3.1	2	2.2	High/low-pressure jetting	Up to 1.2 m	4 vertical and 4 horizontal thrusters	2500		Visual inspection, post-lay burial, cable location/manipulation/cutting.
UNITED KINGDOM										
<i>Submersibles belonging to Global Marine Systems Ltd</i>										
<i>Submersible trencher</i>	17.0	6.6	4	3.4	Fluidization and cutting jets and dredge pump	Up to 1 m depth with cutting and fluidization jets	Three vertical and four horizontal thrusters, track drive differential steering	274		Trench in existing cable and pipe.

Type of submersible	Weight (tons)	Overall length (m)	Width (m)	Height (m)	Trenching system	Trenching	Propulsion	Max operating depth (m)	Max pulling tension (tons)	Capability
<i>Submersible Plough system</i>	9.75	6.1	2.6	2.6	Ploughshare preceded by disc	Immediate burial of cable on ploughing	Towed by support ship	900		Lay and bury cable, umbilical and pipe in one action giving full cable protection.
<i>Remote control submersible 2 off Cirus A&B</i>	3.2	3.5	2.1	2.3	Water jets	Trenching capability 0.3 m	Thrusters (7)	1000		Visual inspection, cable location/inspection/deburial, manipulation. Tools include cable cutter, cable gripper and 2 manipulators with line cutters.
<i>Plough 2 off A&B</i>	14.5	9	4.1	4	Passive blade	Trenching capability 1.0 m	Towed	1000		Steerable, repeater burial.
<i>Remote control submersible ROV 128</i>	7.5	2.9	1.8	2.0	Jetting tool	Trenching capability 0.6 m	Tracked burial Thrusters survey	1000 (burial) 2000 (survey)		Tools include cable cutter, cable gripper and 2 manipulators with line cutters.
<i>Underwater vehicle-MARLIN</i>	7.8	4.191	2.438	3.175	Burial skid	To 1.0 m (Optimized for 0-30 kPa soil)	Hydraulic driven thrusters	2500		Burial, deburial, inspection. Maintenance and repair. Tools include cable cutter, cable gripper.
UNITED KINGDOM <i>Submersibles belonging to Global Marine Systems Ltd</i>										
<i>Scarab I – Umbilically tethered ROV</i>	3.2	2.74	1.82	1.52	Jetting tool	Up to 0.6 m	Thrusters: 2 vertical 4 vectored	2000		Cable detection and inspection. Visual survey. Cable manipulation and cutting. Debris elimination. Cable and repeater burial/deburial.
<i>Subtrack – ROV</i>	10.0	8.0 (Max)	3.7	3.8	Jetting tool	Burial to 1.0 m	Electro-hydraulic track drives	1000		Cable burial and deburial. Inspection. Maintenance and repair.
<i>EUREKA: Deepwater burial + trenching system</i>	17 (Max)	5.5	4.2	3.85	Jetting tool Rock wheel cutter Mechanical chain excavator	1 m 1.2 m 2.2 m	Electro-hydraulic track drives	1500		Capable of burying cable, small flexible flowlines and also rigid pipes. Can also debury cable and restore. Visual and electronic inspections.
<i>Plough 5</i>	14.0	9.0	4.6	3.7	Passive blade	Variable from 0-1100 mm (600-900 mm in all conditions)	Towed	1000		Simultaneously lay and bury cables and umbilicals at varying depths.
<i>Plough 6 and 7</i>	14.0	9.0	4.6	3.7	Passive blade	Max burial depth: 1100 mm	Towed	1000		Simultaneously lay and bury cables and umbilicals at varying depths.

Type of submersible	Weight (tons)	Overall length (m)	Width (m)	Height (m)	Trenching system	Trenching	Propulsion	Max operating depth (m)	Max pulling tension (tons)	Capability
<i>Cable Plough 1000 mm</i>	14.4	9.75	4.1	3.9	Passive blade	1000 mm (Good conditions: 1100 mm; Repeaters/Joints: 500 mm)	Towed	1000		Simultaneously lay and bury cables and umbilicals at varying depths.
<i>Plough D</i>	13.5	9.0	4.6	3.7	Plough share	Variable from 0-1100 mm (600-900 mm in all conditions)	Towed by host vessel	1500		Lay and bury telecom cables, power cables and umbilicals. Cables: Up to 120 mmφ (bury). Joints and repeaters: Up to 400 mmφ (pass).
<i>Plough 7</i>	13.5	9.0	4.6	3.7	Plough share	Variable from 0-1100 mm (600-900 mm in all conditions)	Towed by surface vessel	1000		Lay and bury fibre optic cables, power cables and umbilicals.
<i>Subtrack-Subsea tractor</i>	10.0	8.0 (Max)	3.7	3.8	Jetting tool	Burial to 1.0 m	Electro-hydraulic track drives	1000		Cable burial and deburial. Inspection. Maintenance and repair.
<i>Super Phantom S4-ROV</i>	0.09	1.5	0.75	0.6	–	–	Thrusters 4 prop fwd/aft 2 prop vertical 2 prop transverse	300		Inspect cables and other underwater objects. Can also be used to inspect seabed conditions.
<i>MARCAS-II-ROV</i>	Jet tool mode: 8.0 Track base mode: 7.5	Jet tool mode: 2.9 Track base mode: 5.3	Jet tool mode: 2.3 Track base mode: 4.0	Jet tool mode: 3.2 Track base mode: 3.8	Water jet tool	Up to 1.0 m Track base mode: 1.5 m	4 horizontal, 4 vertical and 2 jet thrusters	Jet tool mode: 2500 Track base mode: 2000		Post-lay burial, maintenance of cable. Can survey seabed.
<i>MARCAS-III-ROV</i>	Jet tool mode: 17.0	6.3	3.7	3.4	Water jet tool	Up to 3.0 m	Thrusters(8) 4 horizontal, 2 vertical, 2 for standby (redundant)	2500		Post-lay burial, maintenance of cable. Can survey seabed.
<i>PLOW-II</i>	18.5 Jet tool mode: 20.0	9.5	5.6	5.0	Plough share Water jet tool	Up to 3.0 m	Towed by cable ship	1500 Jet tool mode: 200	80	Simultaneously lay and bury cables and umbilicals at varying depth.

Type of submersible	Weight (tons)	Overall length (m)	Width (m)	Height (m)	Trenching system	Trenching	Propulsion	Max operating depth (m)	Max pulling tension (tons)	Capability
<i>2) Submersibles belonging to NTT-WE Marine</i>										
<i>Plough-type 7 Submarine cable burying system</i>	21	9.1	5.1	6.0	–	Up to 2.0 m depth immediate burial of cable on ploughing	Towed by support ship	1500		Simultaneous or post-lay burial of cable.
<i>CARBIS-II ROV system</i>	8.0	3.2	2.1	2.8	Water jetting	Trenching capability 1.5 m	Vertical and horizontal thrusters	2500		Cable detection & inspection visual survey. Cable manipulation & cutting. Cable & repeater burial.
<i>MAKO, ROV system (C/S VEGA)</i>	8	3.8	2.5	2.9	Water jetting	Trenching capability 1.5 m	Vertical and horizontal thrusters	2000		Cable detection & inspection visual survey. Cable manipulation & cutting. Cable & repeater burial.
SPAIN										
<i>1) Submersibles belonging to Tyco Submarine Systems Ltd.</i>										
<i>ARADO I</i>	12	9	4.6	4	Plow-share	1100 mm	Towed	1500		Bury cable from 19 to 40 mm. Bury repeaters until 380 mm. Velocity 1 m/s.
<i>NEREUS</i>	8.5	3.2	3.4	2.9		1 m	150 kW	2000		Repair, inspect and bury all types of telephone cable 2 × manipulating 7 functions. Velocity 3 knots.
UNITED STATES OF AMERICA										
<i>Submersibles belonging to Tyco Submarine Systems Ltd.</i>										
<i>PACIFIC SCARAB I</i>	5.48	4.27	1.83	3.05	Jetting modules	560 metres/hour. Soil hardness to 100 kPa.	150 HP Electro-hydraulically powered using 8 thrusters	2500		PACIFIC SCARAB I Submersible Craft Assisting Repair and Burial is a tethered, swimming ROV capable of operating at depths of 2500 metres. It can locate, inspect, retrieve, and bury submarine cables.

Type of submersible	Weight (tons)	Overall length (m)	Width (m)	Height (m)	Trenching system	Trenching	Propulsion	Max operating depth (m)	Max pulling tension (tons)	Capability
<i>SCARAB II</i>	3.45	3.7	2.1	2.3	35 HP cable jetter	255 m/hr depending on soil conditions. Soil hardness to 60 kPa.	Horizontal: 4 × 5 HP electric thrusters Vertical: 2 × 5 HP electric thrusters Aft lateral: 1 × 10 HP hydraulic thruster Bow: 2 × 2.5 HP hydraulic thrusters	1850		SCARAB II Submersible Craft Assisting Repair and Burial is a tethered, swimming ROV capable of operating at depths of 1850 metres. It can locate, inspect, retrieve, and bury submarine cables.
<i>SCARAB IV</i>	4.6	3.4	2.02	1.96	Jetting modules	530 metres/hour Soil hardness to 100 kPa	150 HP electro-hydraulically powered using 8 thrusters	1850		SCARAB IV Submersible Craft Assisting Repair and Burial is a tethered, swimming ROV capable of operating at depths of 1850 metres. It can locate, inspect, retrieve, and bury submarine cables. SCARAB IV is part of the ACMA SCARAB Agreement.
<i>Sea Plow VI</i>	25.5	10.5	6.0	4.3	Towed plow system	1.2 metre burial	Towed by ship	1000		Sea Plow VI is a towed burial tool employing state-of-the-art burial features. It can achieve 1.2 metre burial depth in up to 1000 metre water depth.
<i>Sea Plow VII</i>	14.0	10.5	6.0	4.3	Towed plow system	1.0 metre burial	Towed by ship. 1 thruster for launches and recoveries	1400		Sea Plow VII is a towed burial tool employing state-of-the-art burial features. It can achieve 1.0 metre burial depth in up to 1400 metre water depth.
<i>Sea Plow VIII</i>	19.3	9.2	5.5	3.6	Towed plow system with water jet assist	1.5 metre burial	Towed by ship	1500		Sea Plow VIII is a towed burial tool employing state-of-the-art burial features. It can achieve 1.5 metre burial depth in up to 1500 metre water depth.
UNITED ARAB EMIRATES <i>Submersibles belonging to E-marine PJSC</i>										
<i>SMD Plough</i>	15 12 (Submerged)	9 9.8 (Max)	4.6	4.5	Plough share	1.5 metre	Towrope from surface vessel	2000	50	Cables from 17 mm to 150 mm diameter. Repeaters up to 380 mm diameter.
<i>Olympian T2 ROV</i>	10.1 (Skid) 10.9 (With tracks)	5.2	2.3 (Skid) 3.8 (Track)	2.9	Jet burial tool config.	1 metre cohesive seabed 2 metre non-cohesive seabed	Hydraulic thrusters/tracks	3000	1	Cable burial and deburial. Inspect cables, seabed and underwater objects. 7-function 2-manipulation cutting and grip.

Type of submersible	Weight (tons)	Overall length (m)	Width (m)	Height (m)	Trenching system	Trenching	Propulsion	Max operating depth (m)	Max pulling tension (tons)	Capability
<i>SMD ROV</i>	8 (Skid) 9.2 (With track)	3.8	3.2 (Skid) 3.7 (Tracks)	2.7	Jet burial tool config.	0-1 metre	Hydraulic thrusters/tracks	2000	1	Cable burial and deburial. Inspect cables, seabed and underwater objects. 7-function 2-manipulation cutting and grip.
<i>Navajo ROV</i>	0.042	1.052	0.628	0.411	NA	NA	DC brushless thrusters	300	Power supply 115 VAC/26A 230 VAC/13A	High quality video & sonar surveys. Capable of carrying buoyant work skids and manipulators.
					REPUBLIC OF KOREA <i>Submersibles belonging to KT Submarine</i>					
<i>ROV</i>	18	5.5	3.7	3.2		3 M	800 HP	2500		
<i>Plough</i>	16	9.0	4.1	4.6	–	1.5 M	–	1500		

Bibliography

- [b-ITU-T G.975] Recommendation ITU-T G.975 (2000), *Forward error correction for submarine systems*.
- [b-ITU-T G.975.1] Recommendation ITU-T G.975.1 (2004), *Forward error correction for high bit-rate DWDM submarine systems*.
- [b-ITU-T G.976] Recommendation ITU-T G.976 (2007), *Test methods applicable to optical fibre submarine cable systems*.
- [b-ITU-T G.977] Recommendation ITU-T G.977 (2006), *Characteristics of optically amplified optical fibre submarine cable systems*.
- [b-ITU-T G.978] Recommendation ITU-T G.978 (2006), *Characteristics of optical fibre submarine cables*.
- [b-ITU-T G-Sup.41] ITU-T G-series Recommendations – Supplement 41 (2007), *Design guidelines for optical fibre submarine cable systems*.

SERIES OF ITU-T RECOMMENDATIONS

Series A	Organization of the work of ITU-T
Series D	General tariff principles
Series E	Overall network operation, telephone service, service operation and human factors
Series F	Non-telephone telecommunication services
Series G	Transmission systems and media, digital systems and networks
Series H	Audiovisual and multimedia systems
Series I	Integrated services digital network
Series J	Cable networks and transmission of television, sound programme and other multimedia signals
Series K	Protection against interference
Series L	Construction, installation and protection of cables and other elements of outside plant
Series M	Telecommunication management, including TMN and network maintenance
Series N	Maintenance: international sound programme and television transmission circuits
Series O	Specifications of measuring equipment
Series P	Terminals and subjective and objective assessment methods
Series Q	Switching and signalling
Series R	Telegraph transmission
Series S	Telegraph services terminal equipment
Series T	Terminals for telematic services
Series U	Telegraph switching
Series V	Data communication over the telephone network
Series X	Data networks, open system communications and security
Series Y	Global information infrastructure, Internet protocol aspects and next-generation networks
Series Z	Languages and general software aspects for telecommunication systems