

Recommendation

## **ITU-T G.987.2 (02/2023)**

SERIES G: Transmission systems and media, digital systems and networks

Digital sections and digital line system – Optical line systems for local and access networks

---

### **10-Gigabit-capable passive optical networks (XG-PON): Physical media dependent (PMD) layer specification**



ITU-T G-SERIES RECOMMENDATIONS  
**TRANSMISSION SYSTEMS AND MEDIA, DIGITAL SYSTEMS AND NETWORKS**

INTERNATIONAL TELEPHONE CONNECTIONS AND CIRCUITS	G.100–G.199
GENERAL CHARACTERISTICS COMMON TO ALL ANALOGUE CARRIER-TRANSMISSION SYSTEMS	G.200–G.299
INDIVIDUAL CHARACTERISTICS OF INTERNATIONAL CARRIER TELEPHONE SYSTEMS ON METALLIC LINES	G.300–G.399
GENERAL CHARACTERISTICS OF INTERNATIONAL CARRIER TELEPHONE SYSTEMS ON RADIO-RELAY OR SATELLITE LINKS AND INTERCONNECTION WITH METALLIC LINES	G.400–G.449
COORDINATION OF RADIOTELEPHONY AND LINE TELEPHONY	G.450–G.499
TRANSMISSION MEDIA AND OPTICAL SYSTEMS CHARACTERISTICS	G.600–G.699
DIGITAL TERMINAL EQUIPMENTS	G.700–G.799
DIGITAL NETWORKS	G.800–G.899
DIGITAL SECTIONS AND DIGITAL LINE SYSTEM	G.900–G.999
General	G.900–G.909
Parameters for optical fibre cable systems	G.910–G.919
Digital sections at hierarchical bit rates based on a bit rate of 2048 kbit/s	G.920–G.929
Digital line transmission systems on cable at non-hierarchical bit rates	G.930–G.939
Digital line systems provided by FDM transmission bearers	G.940–G.949
Digital line systems	G.950–G.959
Digital section and digital transmission systems for customer access to ISDN	G.960–G.969
Optical fibre submarine cable systems	G.970–G.979
<b>Optical line systems for local and access networks</b>	<b>G.980–G.989</b>
Metallic access networks	G.990–G.999
MULTIMEDIA QUALITY OF SERVICE AND PERFORMANCE – GENERIC AND USER-RELATED ASPECTS	G.1000–G.1999
TRANSMISSION MEDIA CHARACTERISTICS	G.6000–G.6999
DATA OVER TRANSPORT – GENERIC ASPECTS	G.7000–G.7999
PACKET OVER TRANSPORT ASPECTS	G.8000–G.8999
ACCESS NETWORKS	G.9000–G.9999

*For further details, please refer to the list of ITU-T Recommendations.*

## Recommendation ITU-T G.987.2

### 10-Gigabit-capable passive optical networks (XG-PON): Physical media dependent (PMD) layer specification

#### Summary

Recommendation ITU-T G.987.2 describes the physical layer requirements and specifications for the XG-PON physical media dependent (PMD) layer. Wavelength enhancement bands are described in Recommendation ITU-T G.987.1. The transmission convergence (TC) layer is described in Recommendation ITU-T G.987.3. The optical network unit (ONU) management and control interface (OMCI) specifications are described in Recommendation ITU-T G.988.

Recommendation ITU-T G.987.2 describes a flexible optical fibre access network capable of supporting the bandwidth requirements of business and residential services. The G.987 series of standards allows for multiple upstream and downstream line rates. This Recommendation currently defines one type of 10-Gigabit-capable passive optical network (XG-PON) system with an asymmetric nominal line rate of 9.95328 Gbit/s in the downstream direction and 2.48832 Gbit/s in the upstream direction.

This Recommendation describes a system that represents an evolutionary development from the systems described in the ITU-T G.984 series. To the greatest extent possible, this Recommendation maintains the requirements of Recommendation ITU-T G.984.1 to ensure maximal continuity with existing systems and optical fibre infrastructure.

Amendment 2 continues the maintenance and evolution of physical media dependent (PMD) layer specifications for XG-PON as defined in this Recommendation. It includes technical updates and corrections for changing references to XG-PON1 to XG-PON, replacing the mask of the eye diagram for the ONU transmitter, updating the DD40 downstream specification, correcting the X/S tolerance mask for ONU and updating the X/S tolerance mask for the optical trunk line (OLT).

This revision adds a new annex specifying out-of-band noise limits on XG-PON ONUs to reduce the impact on other systems coexisting on the same PON.

#### History

Edition	Recommendation	Approval	Study Group	Unique ID*
1.0	ITU-T G.987.2	2010-01-13	15	<a href="http://handle.itu.int/11.1002/1000/10411">11.1002/1000/10411</a>
2.0	ITU-T G.987.2	2010-10-07	15	<a href="http://handle.itu.int/11.1002/1000/10889">11.1002/1000/10889</a>
2.1	ITU-T G.987.2 (2010) Amd. 1	2012-02-13	15	<a href="http://handle.itu.int/11.1002/1000/11499">11.1002/1000/11499</a>
3.0	ITU-T G.987.2	2016-02-26	15	<a href="http://handle.itu.int/11.1002/1000/12832">11.1002/1000/12832</a>
3.1	ITU-T G.987.2 (2016) Amd. 1	2017-08-13	15	<a href="http://handle.itu.int/11.1002/1000/13290">11.1002/1000/13290</a>
3.2	ITU-T G.987.2 (2016) Amd. 2	2020-10-29	15	<a href="http://handle.itu.int/11.1002/1000/14491">11.1002/1000/14491</a>
4.0	ITU-T G.987.2	2023-02-22	15	<a href="http://handle.itu.int/11.1002/1000/15124">11.1002/1000/15124</a>

#### Keywords

10-Gigabit-capable passive optical network, FTTx network, OLT, ONU, optic, optical network terminal (ONT), passive optical network (PON), physical layer interfaces, physical layer requirements, physical layer specification, PMD, XG-PON.

---

\* To access the Recommendation, type the URL <http://handle.itu.int/> in the address field of your web browser, followed by the Recommendation's unique ID. For example, <http://handle.itu.int/11.1002/1000/11830-en>.

## FOREWORD

The International Telecommunication Union (ITU) is the United Nations specialized agency in the field of telecommunications, information and communication technologies (ICTs). The ITU Telecommunication Standardization Sector (ITU-T) is a permanent organ of ITU. ITU-T is responsible for studying technical, operating and tariff questions and issuing Recommendations on them with a view to standardizing telecommunications on a worldwide basis.

The World Telecommunication Standardization Assembly (WTSA), which meets every four years, establishes the topics for study by the ITU-T study groups which, in turn, produce Recommendations on these topics.

The approval of ITU-T Recommendations is covered by the procedure laid down in WTSA Resolution 1.

In some areas of information technology which fall within ITU-T's purview, the necessary standards are prepared on a collaborative basis with ISO and IEC.

## NOTE

In this Recommendation, the expression "Administration" is used for conciseness to indicate both a telecommunication administration and a recognized operating agency.

Compliance with this Recommendation is voluntary. However, the Recommendation may contain certain mandatory provisions (to ensure, e.g., interoperability or applicability) and compliance with the Recommendation is achieved when all of these mandatory provisions are met. The words "shall" or some other obligatory language such as "must" and the negative equivalents are used to express requirements. The use of such words does not suggest that compliance with the Recommendation is required of any party.

## INTELLECTUAL PROPERTY RIGHTS

ITU draws attention to the possibility that the practice or implementation of this Recommendation may involve the use of a claimed Intellectual Property Right. ITU takes no position concerning the evidence, validity or applicability of claimed Intellectual Property Rights, whether asserted by ITU members or others outside of the Recommendation development process.

As of the date of approval of this Recommendation, ITU had not received notice of intellectual property, protected by patents/software copyrights, which may be required to implement this Recommendation. However, implementers are cautioned that this may not represent the latest information and are therefore strongly urged to consult the appropriate ITU-T databases available via the ITU-T website at <http://www.itu.int/ITU-T/ipr/>.

© ITU 2023

All rights reserved. No part of this publication may be reproduced, by any means whatsoever, without the prior written permission of ITU.

## Table of Contents

	<b>Page</b>
1 Scope .....	1
2 References.....	1
3 Definitions .....	2
3.1 Terms defined elsewhere .....	2
3.2 Terms defined in this Recommendation .....	2
4 Abbreviations and acronyms .....	2
5 Conventions .....	3
6 Architecture of the optical access network.....	3
6.1 Classes for optical path loss.....	4
6.2 Categories for fibre differential distance .....	4
7 Services .....	5
8 User-network interface and service node interface.....	5
9 Optical network requirements .....	5
9.1 Layered structure of XG-PON optical network.....	5
9.2 Physical media dependent layer requirements for the XG-PON.....	5
10 X/S tolerance masks .....	17
10.1 X/S tolerance mask for ONU.....	17
10.2 X/S tolerance mask for OLT.....	18
11 Upstream physical layer overhead .....	19
Annex A – ONU out-of-band power spectral density .....	20
Appendix I – Examples of wavelength allocation for XG-PON, G-PON and video distribution services.....	22
Appendix II – Physical layer measurements required to support optical layer supervision ....	23
Appendix III – Allocation of the physical layer overhead time.....	24
Appendix IV – Jitter budget specifications .....	27
IV.1 The concept of jitter budget.....	27
IV.2 Definition of test points.....	28
IV.3 Jitter budget specification for XG-PON.....	29
IV.4 Jitter measurements for compliance to budget .....	29
Appendix V – Measurement of burst mode acquisition time and burst mode eye opening at OLT .....	31
Bibliography .....	34



## Recommendation ITU-T G.987.2

### 10-Gigabit-capable passive optical networks (XG-PON): Physical media dependent (PMD) layer specification

#### 1 Scope

This Recommendation pertains to flexible access networks using optical fibre technology. The focus is primarily on a network supporting services with bandwidth requirements ranging from those of voice services to data services running at up to 10 Gbit/s. Also included are broadcast services.

This Recommendation describes characteristics of the physical medium dependent (PMD) layer of an optical access network (OAN) with the capability of transporting various services between the user-network interface and the service node interface.

The OAN described in this Recommendation enables the network operator to provide a flexible upgrade to meet future customer requirements, in particular, in the area of the optical distribution network (ODN). The ODN considered is based on a point-to-multipoint tree and branch option.

#### 2 References

The following ITU-T Recommendations and other references contain provisions which, through reference in this text, constitute provisions of this Recommendation. At the time of publication, the editions indicated were valid. All Recommendations and other references are subject to revision; users of this Recommendation are therefore encouraged to investigate the possibility of applying the most recent edition of the Recommendations and other references listed below. A list of the currently valid ITU-T Recommendations is regularly published. The reference to a document within this Recommendation does not give it, as a stand-alone document, the status of a Recommendation.

- [ITU-T G.652] Recommendation ITU-T G.652 (2016), *Characteristics of a single-mode optical fibre and cable.*
- [ITU-T G.657] Recommendation ITU-T G.657 (2016), *Characteristics of a bending loss insensitive single-mode optical fibre and cable.*
- [ITU-T G.783] Recommendation ITU-T G.783 (2006), *Characteristics of synchronous digital hierarchy (SDH) equipment functional blocks.*
- [ITU-T G.825] Recommendation ITU-T G.825 (2000), *The control of jitter and wander within digital networks which are based on the synchronous digital hierarchy (SDH).*
- [ITU-T G.957] Recommendation ITU-T G.957 (2006), *Optical interfaces for equipments and systems relating to the synchronous digital hierarchy.*
- [ITU-T G.959.1] Recommendation ITU-T G.959.1 (2016), *Optical transport network physical layer interfaces.*
- [ITU-T G.982] Recommendation ITU-T G.982 (1996), *Optical access networks to support services up to the ISDN primary rate or equivalent bit rates.*
- [ITU-T G.984.1] Recommendation ITU-T G.984.1 (2008), *Gigabit-capable passive optical networks (GPON): General characteristics.*
- [ITU-T G.984.2] Recommendation ITU-T G.984.2 (2003, as amended), *Gigabit-capable passive optical networks (G-PON): Physical media dependent (PMD) layer specification.*

- [ITU-T G.987] Recommendation ITU-T G.987 (2012), *10-Gigabit-capable passive optical network (XG-PON) systems: Definitions, abbreviations and acronyms.*
- [ITU-T G.987.1] Recommendation ITU-T G.987.1 (2010), *10 Gigabit-capable passive optical network (XG-PON): General requirements.*
- [ITU-T G.987.3] Recommendation ITU-T G.987.3 (2014), *10-Gigabit-capable passive optical networks (XG-PON): Transmission convergence (TC) layer specification.*
- [ITU-T G.988] Recommendation ITU-T G.988 (2022), *ONU management and control interface (OMCI) specification.*
- [ITU-T L.313] Recommendation ITU-T L.313 (2007), *Optical fibre cable maintenance criteria for in-service fibre testing in access networks.*

## **3 Definitions**

### **3.1 Terms defined elsewhere**

This Recommendation uses the following terms defined elsewhere:

See clause 3 of [ITU-T G.987].

### **3.2 Terms defined in this Recommendation**

This Recommendation defines the following term:

**3.2.1 out-of-band power spectral density (OOB-PSD):** The optical power spectral density outside the operating wavelength band measured at the appropriate reference point (S/R for downstream direction, R/S for upstream direction).

NOTE – Measurements are averaged over the time periods when the transmitter is enabled, or when the transmitter is not enabled but the allocated transient time has not yet elapsed. The OOB-PSD is expressed as the total integrated power within a sliding spectral window of known width.

## **4 Abbreviations and acronyms**

See clause 4 of [ITU-T G.987].

## **5 Conventions**

See clause 5 of [ITU-T G.987].

## **6 Architecture of the optical access network**

See [ITU-T G.984.1]. For convenience, Figure 1 of [ITU-T G.984.2] is reproduced below.



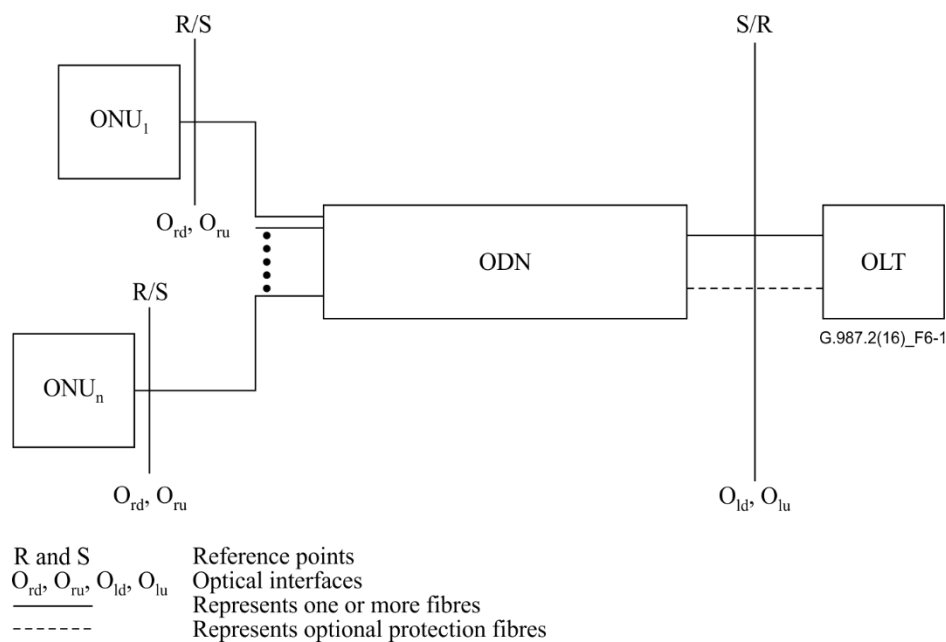

**Figure 6-1 – Generic physical configuration of the optical distribution network (reproduced from Figure 1 of [ITU-T G.984.2])**

The following reference points are defined in Figure 6-1:

- S: Point on the optical fibre just after the optical trunk line (OLT)[Downstream]/optical network unit (ONU)[Upstream] optical connection point (i.e., optical connector or optical splice).
- R: Point on the optical fibre just before the ONU[Downstream]/OLT[Upstream] optical connection point (i.e., optical connector or optical splice).
- S/R, R/S: Combination of points S and R existing simultaneously in a single fibre, when operating in bidirectional mode.
- $O_{ru}, O_{rd}$ : Optical interface at the reference point R/S between the ONU and the ODN for the upstream and downstream directions, respectively.
- $O_{lu}, O_{ld}$ : Optical interfaces at the reference point S/R between the OLT and the ODN for the upstream and downstream directions, respectively.

The two directions for optical transmission in the ODN are identified as follows:

- downstream direction for signals travelling from the OLT to the ONU(s), and
- upstream direction for signals travelling from the ONU(s) to the OLT.

Transmission in downstream and upstream directions takes place on the same fibre and components (duplex/diplex configuration).

### 6.1 Classes for optical path loss

Recommended classes for optical path loss are shown in Table 6-1.

**Table 6-1 – Classes for optical path loss defined in this Recommendation**

	Nominal1 class (N1 class)	Nominal2 class (N2 class)	Extended1 class (E1 class)	Extended2 class (E2 class)
Minimum loss	14 dB	16 dB	18 dB	20 dB
Maximum loss	29 dB	31 dB	33 dB	35 dB

For single-star architectures, the absence of optical branching devices may result in optical path losses of less than 5 dB. In such a case, the ODN must contain additional optical attenuators guaranteeing minimum channel insertion loss for the given class to prevent potential damage to receivers.

## 6.2 Categories for fibre differential distance

Categories for fibre differential distance

Recommended categories for fibre differential distance (DD) are shown in Table 6-2.

**Table 6-2 – Categories for fibre differential distance defined in G.987.2**

	<b>DD20</b>	<b>DD40</b>
Maximum differential distance	20 km	40 km

For DD40 ODNs, due to the intrinsic wavelength dependence of the optical fibre loss [ITU-T G.652], the fibre attenuation coefficient at the downstream wavelength (1577 nm) is lower than that at the upstream wavelength (1270 nm) resulting in a downstream loss margin. This margin is expected to be at least 1 dB for a fibre length greater than 20 km. The additional maximum optical path penalty allowed for DD40 is therefore fully compensated by the lower fibre loss at the downstream wavelength. Thus, the other PMD values (except optical path penalty (OPP)) for DD40 do not change from those PMD values specified for DD20.

In DD40 deployments, the actual fibre cable loss characteristics should be assessed, to make sure there is the required extra margin of 1dB with respect to the maximum OPL class loss at the downstream wavelength for ODN branches with a maximum OLT-ONU fibre length greater than 20 km.

## 7 Services

See clause 7 of [ITU-T G.987.1].

## 8 User-network interface and service node interface

See Appendix I of [ITU-T G.987.1].

## 9 Optical network requirements

### 9.1 Layered structure of XG-PON optical network

See clause 5.2.5 of [ITU-T G.987.1].

### 9.2 Physical media dependent layer requirements for the XG-PON

All parameters are specified as follows, and are in accordance with Tables 9-2 to 9-4.

There are two ONU types, based on different ONU receiver sensitivity.

All parameter values specified are worst-case values, to be met over the range of standard operating conditions (i.e., temperature and humidity), and they include ageing effects. The parameters are specified relative to an optical section design objective of a bit error ratio (BER) not worse than the values specified in Table 9-3 and Table 9-4, for the extreme case of optical path attenuation and dispersion conditions.

In particular, the values given in Table 9-3 and Table 9-4 are valid for the cases of an enhancement band, as described in clause 10.

### 9.2.1 Line rate

The transmission line rate is a multiple of 8 kHz. The target standardized 10-gigabit-capable passive optical network (XG-PON) system supports the following variant: XG-PON with a downstream line rate of 9.95328 Gbit/s and an upstream line rate of 2.48832 Gbit/s.

Parameters to be defined are categorized by downstream and upstream, and the nominal line rate as shown in Table 9-1.

**Table 9-1 – Relation between parameter categories and tables**

Variant	Transmission direction	Nominal line rate [Gbit/s]	Reference table
XG-PON	Downstream	9.95328	Table 9-3
	Upstream	2.48832	Table 9-4

#### 9.2.1.1 Downstream accuracy

When the optical trunk line (OLT) and the end office are in their normal operating state, the OLT is typically traceable to a Stratum-1 reference (accuracy of  $1 \times 10^{-11}$ ). When the OLT is in its free-running mode, the accuracy of the downstream signal is at least that of a Stratum-4 clock ( $3.2 \times 10^{-5}$ ). OLTs intended for timing-critical applications such as mobile backhaul may require stratum-3 quality in free-running mode.

NOTE – The OLT may derive its timing from either a dedicated timing signal source or from a synchronous data interface (line timing). A packet-based timing source may also be used.

#### 9.2.1.2 Upstream accuracy

When in one of its operating states and granted an allocation, the ONU shall transmit its signal with frequency accuracy equal to that of the received downstream signal.

### 9.2.2 Forward error correction code selection for XG-PON

See clause 10.3 of [ITU-T G.987.3].

### 9.2.3 Physical media and transmission method

#### 9.2.3.1 Transmission medium

This Recommendation is based on the fibre described in [ITU-T G.652]. Other fibre types may be compatible with this Recommendation, e.g., [ITU-T G.657], used, for example, for in-building cabling, drop section.

#### 9.2.3.2 Transmission direction

The signal is transmitted both upstream and downstream through the transmission medium.

#### 9.2.3.3 Transmission methodology

Bidirectional transmission is accomplished by use of wavelength division multiplexing (WDM) technique on a single fibre.

### 9.2.4 Line code

The scrambling method is defined in [ITU-T G.987.3].

The convention used for optical logic levels is:

- high level of light emission for a binary ONE;
- low level of light emission for a binary ZERO.

#### 9.2.4.1 Downstream

Downstream line coding for XG-PON: NRZ.

#### 9.2.4.2 Upstream

Upstream line coding for XG-PON: NRZ.

#### 9.2.5 Operating wavelength

##### 9.2.5.1 Downstream wavelength allocation

The operating wavelength range for XG-PON for the downstream direction is defined in Table 9-3.

##### 9.2.5.2 Upstream wavelength allocation

The operating wavelength range for XG-PON for the upstream direction is defined in Table 9-4.

#### 9.2.6 XG-PON PMD parameters

##### 9.2.6.1 XG-PON compatible ODN

XG-PON shall operate over an ODN whose parameters are described by Table 9-2.

**Table 9-2 – Physical parameters of a simple ODN (ODS)**

Item	Unit	Specification
Fibre type (Note)	–	[ITU-T G.652], or compatible
Attenuation range (as defined in clause 6.1)	dB	N1 class: 14 – 29 N2 class: 16 – 31 E1 class: 18 – 33 E2 class: 20 – 35
Maximum fibre distance between S/R and R/S points	km	DD20: 20 DD40: 40
Minimum fibre distance between S/R and R/S points	km	0
Bidirectional transmission	–	1-fibre WDM
Maintenance wavelength	nm	See [ITU-T L.313]
NOTE – See clause 9.2.3.1		

##### 9.2.6.2 Optical interface parameters of 9.95328 Gbit/s downstream direction

**Table 9-3 – Optical interface parameters of 9.95328 Gbit/s downstream direction**

Item	Unit	Value
<b>OLT transmitter (optical interface O<sub>ld</sub>)</b>		
Nominal line rate	Gbit/s	9.95328
Operating wavelength (Note 1)	nm	1575 – 1580
Line code	–	NRZ
Mask of the transmitter eye diagram	–	see clause 9.2.7.6.1
Maximum reflectance at S/R, measured at transmitter wavelength	dB	NA
Minimum optical return loss (ORL) of ODN at O <sub>lu</sub> and O <sub>ld</sub> (Notes 2 and 3)	dB	more than 32

**Table 9-3 – Optical interface parameters of 9.95328 Gbit/s downstream direction**

Item	Unit	Value					
		N1	N2		E1	E2	
ODN Class			N2a	N2b		E2a	E2b
Mean launched power MIN	dBm	+2.0	+4.0	+10.5	+6	+8	+14.5
Mean launched power MAX	dBm	+6.0	+8.0	+12.5	+10	+12	+16.5
Launched optical power without input to the transmitter	dBm	NA					
Minimum extinction ratio	dB	8.2					
Transmitter tolerance to reflected optical power (Note 7)	dB	more than –15					
Dispersion Range	ps/nm	0-400 (DD20) 0-800 (DD40)					
Minimum side-mode-suppression ratio	dB	30					
Maximum differential optical path loss	dB	15					
Jitter generation	–	see clause 9.2.9.7.3					
<b>ONU receiver (optical interface O<sub>rd</sub>)</b>							
Maximum OPP (Note 6, Note 9)	dB	1.0 (DD20) 2.0 (DD40)					
Maximum reflectance at R/S, measured at receiver wavelength	dB	less than –20					
BER reference level	–	10 <sup>-3</sup> (Note 4)					
ODN Class		N1	N2		E1	E2	
			N2a	N2b		E2a	E2b
Minimum sensitivity at BER reference level (Note 5)	dBm	–28.0	–28.0	–21.5	–28.0	–28.0	–21.5
Minimum overload at BER reference level	dBm	–8.0	–8.0	–3.5	–8.0	–8.0	–3.5
Consecutive identical digit immunity	bit	more than 72					
Jitter tolerance	–	see clause 9.2.9.7.2					
Receiver tolerance to reflected optical power (Note 8)	dB	less than 10					
<p>NOTE 1 – In the case of outdoor OLT deployment, it is allowed for the operating wavelength to span between 1 575 and 1 581 nm.</p> <p>NOTE 2 – There are optional cases where the "minimum optical return loss (ORL) of ODN at O<sub>lu</sub> and O<sub>ld</sub>" can be as low as 20 dB (see [b-ITU-T G.983.1] Appendix I).</p> <p>NOTE 3 – The value of ONU transceiver reflectance corresponding to the "minimum optical return loss (ORL) of ODN at O<sub>lu</sub> and O<sub>ld</sub>" is –20 dB (see [b-ITU-T G.983.1] Appendix II).</p> <p>NOTE 4 – See [b-ITU-T G Suppl.39], clause 9.4.1 for additional details.</p> <p>NOTE 5 – This sensitivity shall be met in the presence of G-PON and video overlay on the same ODN. If either G-PON, or video overlay, or both are absent, the sensitivity may be different (precise value is for further study).</p> <p>NOTE 6 – The specified penalty must be met by optics complying with the specified launched power range. If a transmitter exhibits a higher penalty, it can still comply if it equally increases the minimum</p>							

**Table 9-3 – Optical interface parameters of 9.95328 Gbit/s downstream direction**

Item	Unit	Value
launched power while remaining under the maximum launched power. In no case should the OPP exceed 2.5 dB.		
NOTE 7 – Parameter known in [ITU-T G.984.2] as "Tolerance to the transmitter incident light power".		
NOTE 8 – Parameter known in [ITU-T G.984.2] as "Tolerance to the reflected optical power".		
NOTE 9 – For ODN branches with a maximum OLT-ONU fibre length greater than 20 km, the applicable maximum OPP is the DD40 value. However, the fibre loss at the downstream wavelength is lower than that at the upstream wavelength and this more than compensates for the extra OPP of DD40 vs. DD20 (i.e., the upstream wavelength loss limits the link distance and therefore loss margin exists for the downstream signal). For systems that connect ONUs at both short and long distances (up to 40 km) to the same OLT port, the optical link must comply with the DD20 maximum OPP value for ONUs at < =20 km and the DD40 maximum OPP value for ONUs at > 20 km.		

**9.2.6.3 Optical interface parameters of 2.48832 Gbit/s upstream direction**

**Table 9-4 – Optical interface parameters of 2.48832 Gbit/s upstream direction**

Item	Unit	Value			
<b>ONU transmitter (optical interface O<sub>ru</sub>)</b>					
Nominal line rate	Gbit/s	2.48832			
Operating wavelength	nm	1260 – 1280			
Line code	–	NRZ			
Mask of the transmitter eye diagram	–	see clause 9.2.7.6.2			
Maximum reflectance at R/S, measured at transmitter wavelength	dB	less than –6			
Minimum optical return loss (ORL) of ODN at O <sub>ru</sub> and O <sub>rd</sub> (Notes 1 and 2)	dB	more than 32			
ODN Class		N1	N2	E1	E2
Mean launched power MIN	dBm	+2.0	+2.0	+2.0	+2.0
Mean launched power MAX	dBm	+7.0	+7.0	+7.0	+7.0
Launched optical power without input to the transmitter (Note 3)	dBm	less than "Minimum sensitivity at BER reference level" – 10			
Maximum Tx enable (Note 3)	bits	32			
Maximum Tx disable (Note 3)	bits	32			
Minimum extinction ratio	dB	8.2			
Transmitter tolerance to reflected optical power (Note 8)	dB	more than –15			
Dispersion range (Note 4, Note 5)	ps/nm	0 to –140 (DD20) 0 to –280 (DD40)			
Minimum side mode suppression ratio (Note 10)	dB	30			
Jitter transfer	–	see clause 9.2.9.7.1			
Jitter generation	–	see clause 9.2.9.7.3			
<b>OLT receiver (optical interface O<sub>lu</sub>)</b>					
Maximum OPP (Note 7)	dB	0.5			

**Table 9-4 – Optical interface parameters of 2.48832 Gbit/s upstream direction**

Item	Unit	Value			
Maximum reflectance at S/R, measured at receiver wavelength	dB	less than -20			
BER reference level	–	10 <sup>-4</sup> (Note 6)			
ODN Class		N1	N2	E1	E2
Minimum sensitivity at BER reference level	dBm	-27.5	-29.5	-31.5	-33.5
Minimum overload at BER reference level	dBm	-7.0	-9.0	-11	-13
Consecutive identical digit immunity	bit	more than 72			
Jitter tolerance	–	see clause 9.2.9.7.2			
Receiver tolerance to reflected optical power (Note 9)	dB	less than 10			

NOTE 1 – There are optional cases where the "minimum optical return loss (ORL) of ODN at  $O_{ru}$  and  $O_{rd}$ " can be as low as 20 dB (see [b-ITU-T G.983.1] Appendix I).

NOTE 2 – The value of ONU transceiver reflectance corresponding to the "minimum optical return loss (ORL) of ODN at  $O_{ru}$  and  $O_{rd}$ " is -20 dB (see [b-ITU-T G.983.1] Appendix II).

NOTE 3 – As defined in clause 9.2.7.3.1.

NOTE 4 – Dispersion range is considered to be the most appropriate method of specifying a laser's spectral characteristic. These values are considered to be compatible with the older method of specifying values using maximum -20 dB width, for line rates below 2.5 Gbit/s.

NOTE 5 – The equivalent maximum -20 dB width value is specified as less than 1 nm.

NOTE 6 – See [b-ITU-T G Suppl.39], clause 9.4.1 for additional details.

NOTE 7 – The specified penalty is valid up to a 40 km link distance.

NOTE 8 – Parameter known in [ITU-T G.984.2] as "Tolerance to the transmitter incident light power".

NOTE 9 – Parameter known in [ITU-T G.984.2] as "Tolerance to the reflected optical power".

NOTE 10 – See Annex A for additional spectral requirements that limit harmful crosstalk penalties on the upstream transmissions of coexisting PON systems. Other means to facilitate coexistence are described in [ITU-T G.9805].

### 9.2.7 Transmitter at $O_{ld}$ and $O_{ru}$

All parameters are specified as follows, and are in accordance with Table 9-3 and Table 9-4.

#### 9.2.7.1 Source type

Considering the attenuation/dispersion characteristics of the target fibre channel, feasible transmitter devices include only single-longitudinal mode (SLM) lasers. The indication of a nominal source type in this Recommendation is not a requirement though it is also expected that only SLM lasers will meet all the distance and line rate requirements of the XG-PON systems both for the downstream and upstream links.

The use of multilongitudinal mode (MLM) lasers is not contemplated in this Recommendation, due to their practical distance/line rate limitations.

#### 9.2.7.2 Spectral characteristics

For SLM lasers, the laser is specified as its fibre dispersion range, the range over which the laser characteristics and fibre dispersion result in a defined penalty at a specified fibre distance, under standard operating conditions. Additionally, for control of mode partition noise in SLM systems, a minimum value for the laser side-mode suppression ratio is specified. The actual spectral

characteristics are limited by the maximum amount of OPP produced with the worst-case optical dispersion in the data channel.

The use of MLM lasers is not contemplated in this Recommendation.

### 9.2.7.3 Mean launched power

The mean launched power at  $O_{ld}$  and  $O_{ru}$  is the average power of a pseudo-random data sequence coupled into the fibre by the transmitter. It is given as a range to allow for some cost optimization and to cover all allowances for operation under standard operating conditions, transmitter connector degradation, measurement tolerances and ageing effects.

In the operating state, the lower figure is the minimum power to be provided and the higher one is the power never to be exceeded.

NOTE – Measurement of the launched power at the  $O_{ru}$  optical interface must take into account the burst nature of the upstream traffic transmitted by the ONUs.

#### 9.2.7.3.1 Launched optical power without input to the transmitter

In the upstream direction, the ONU transmitter should ideally launch no power into the fibre in all bursts which are not assigned to that ONU. However, an optical power level less than or equal to the launched power without input to the transmitter is allowed during bursts which are not assigned to that ONU. During the Tx enable bit period the transmit levels are not specified, provided they comply with the PMD Tables 9-3 and 9-4. During the Tx disable bit period immediately following the assigned burst, the maximum launch power level allowed is the zero-level corresponding to the minimum extinction ratio specified in Tables 9-3 and 9-4.

The specification of the maximum number of Tx enable and Tx disable bit periods is provided in Table 9-3 and Table 9-4.

The relationship between ONU power levels and burst times is shown in Figure 9-1.

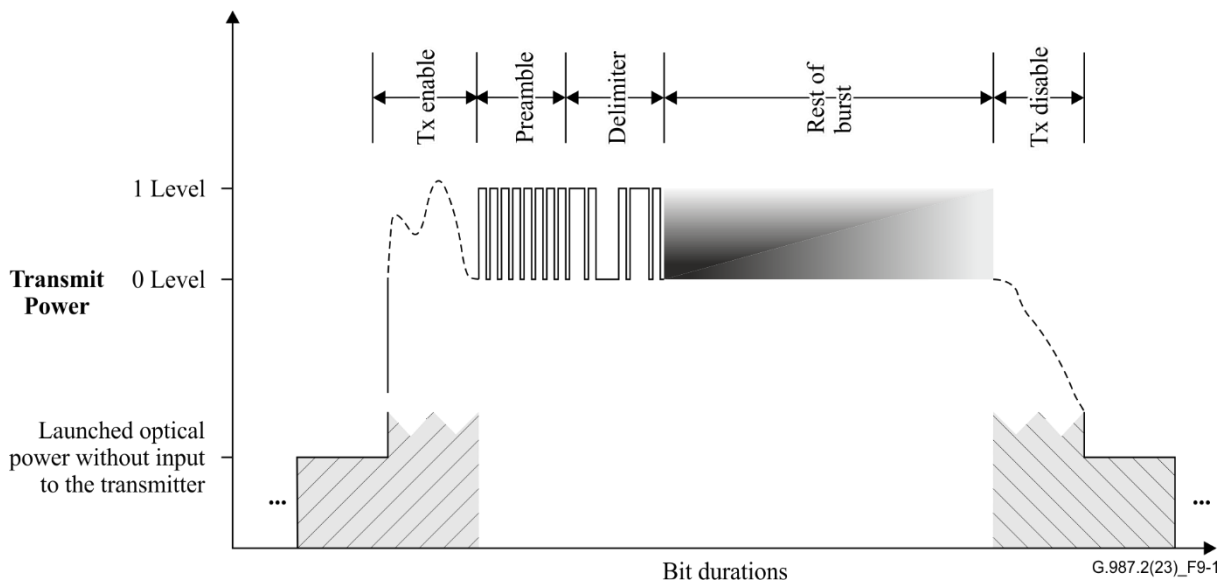

Figure 9-1 – Relationship between ONU power levels and burst times

#### 9.2.7.4 Minimum extinction ratio

The extinction ratio (ER) is defined as:

$$ER = 10 \log_{10} (A/B)$$

where  $A$  is the average optical power level at the centre of the binary 1 and  $B$  is the average optical power level at the centre of the binary 0.



The ER for the upstream direction burst mode signal is applied from the first bit of the preamble to the last bit of the burst signal, inclusive.

### 9.2.7.5 Maximum reflectance of equipment, measured at transmitter wavelength

Reflections from equipment (ONU/OLT) back to the cable plant are specified by the maximum permissible reflectance of equipment measured at  $O_{ld}/O_{ru}$ , in accordance with Table 9-3 and Table 9-4.

### 9.2.7.6 Mask of transmitter eye diagram

In this Recommendation, general transmitter pulse shape characteristics including rise time, fall time, pulse overshoot, pulse undershoot and ringing, all of which should be controlled to prevent excessive degradation of the receiver sensitivity, are specified in the form of a mask of the transmitter eye diagram at  $O_{ld}/O_{ru}$ . For the purpose of assessing the transmit signal, it is important to consider not only the eye opening, but also the overshoot and undershoot limitations.

#### 9.2.7.6.1 OLT transmitter

The parameters specifying the mask of the eye diagram (see Figure 9-2) for the OLT transmitter are shown in Table 9-5. The test set-up for the measurement of the mask of the eye diagram is shown in Figure 9-3.

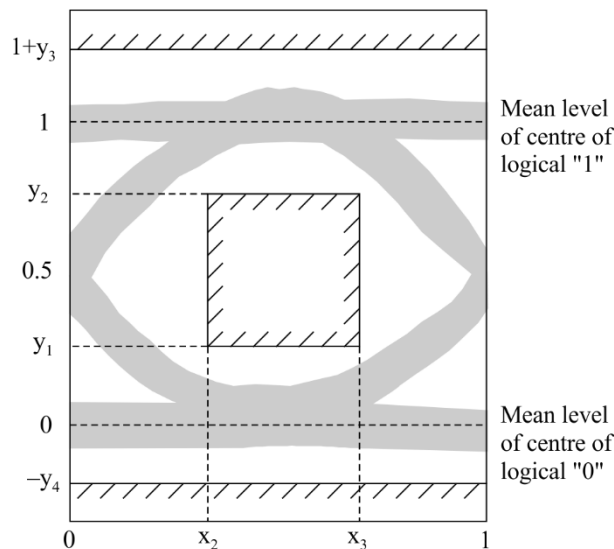

G.987.2(16)\_F9-2

**Figure 9-2 – Mask of the eye diagram for OLT transmitter**

**Table 9-5 – Mask of the eye diagram for OLT transmitter – Numeric values**

	<b>9.95328 Gbit/s</b>
$x_3 - x_2$ (Note 1)	0.2
$y_1$	0.25
$y_2$	0.75
$y_3$	0.25
$y_4$	0.25

NOTE 1 –  $x_2$  and  $x_3$  of the rectangular eye mask need not be equidistant with respect to the vertical axes at 0 UI and 1 UI.

NOTE 2 – The values are taken from [ITU-T G.959.1], clause 7.2.2.14.

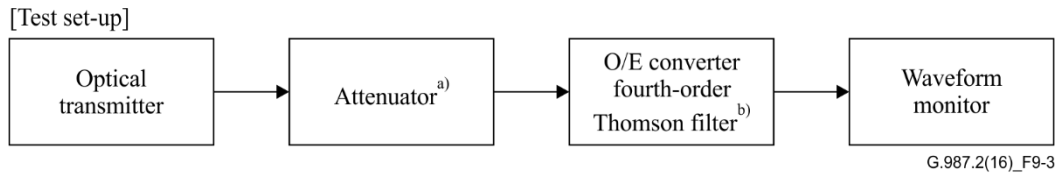

<sup>a)</sup> Attenuator is used if necessary.

<sup>b)</sup> Cut-off frequency (3 dB attenuation frequency) of the filter is 0.75 times output nominal bit rate.

**Figure 9-3 – Test set-up for mask of the eye diagram for OLT transmitter**

### 9.2.7.6.2 ONU transmitter

The parameters specifying the mask of the eye diagram (see Figure 9-4) for the ONU transmitter are shown in Table 9-6. The test set-up for the measurement of the mask of the eye diagram is shown in Figure 9-5.

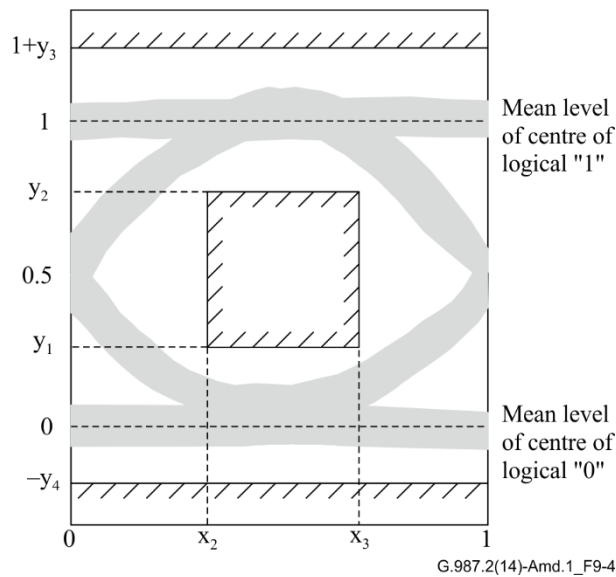
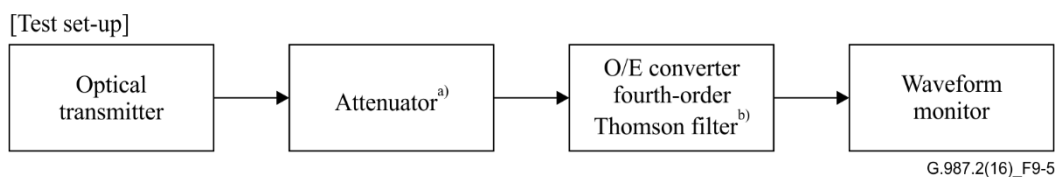

**Figure 9-4 – Mask of the eye diagram for ONU transmitter**

**Table 9-6 – Mask of the eye diagram for ONU transmitter – Numeric values**

	2.48832 Gbit/s	9.95328 Gbit/s
$x_3 - x_2$ (Note 1)	0.2	0.2
$y_1, y_3, y_4$	0.25	0.25
$y_2$	0.75	0.75

NOTE 1 – Parameters  $x_2$  and  $x_3$  of the rectangular eye mask need not be equidistant with respect to the vertical axes at 0 UI and 1 UI.  
 NOTE 2 – The values are taken from [ITU-T G.957], clause 6.2.5.



<sup>a)</sup> Attenuator is used if necessary.

<sup>b)</sup> Cut-off frequency (3 dB attenuation frequency) of the filter is 0.75 times output nominal bit rate.

**Figure 9-5 – Test set-up for mask of the eye diagram for ONU transmitter**

The mask of the eye diagram for the upstream direction burst mode signal is applied from the first bit of the preamble to the last bit of the burst signal, inclusive.

#### **9.2.7.7 Transmitter tolerance to reflected optical power**

The specified transmitter performance must be met in the presence of the optical reflection level at reference point S specified in Table 9-3 and Table 9-4.

### **9.2.8 Optical path between $O_{ld}/O_{ru}$ and $O_{rd}/O_{lu}$**

#### **9.2.8.1 Attenuation range**

Four classes of attenuation ranges are specified in clause 6.1.

Attenuation specifications are assumed to be worst-case values at all wavelengths specified in Table 9-3 and Table 9-4, including losses due to splices, connectors, optical attenuators (if used) or other passive optical devices, and any additional cable margin to cover allowances for:

- 1) future modifications to the cable configuration (additional splices, increased cable lengths, etc.);
- 2) fibre cable performance variations due to environmental factors; and
- 3) degradation of any connector, optical attenuators (if used) or other passive optical devices between points S and R, when provided.

#### **9.2.8.2 Minimum optical return loss of the cable plant at point R/S, including any connectors**

Overall minimum optical return loss (ORL) specification at point R/S in the ODN is specified in Table 9-3 and Table 9-4.

Optionally, minimum ORL specification at point S in the ODN is specified in Note 2 of Table 9-3 and Table 9-4.

NOTE – The overall reflectance at the S/R point for an ODN model is dominated by the optical connectors at the optical distribution frame (ODF). The maximum reflectance of a single discrete element within [ITU-T G.982] is –35 dB. The reflectance from the two ODF connectors leads to a figure of –32 dB. However, based on another network model, the overall reflectance may become worse than –20 dB.

#### **9.2.8.3 Maximum discrete reflectance between points S and R**

All discrete reflectances in the ODN shall be better than –35 dB as defined in [ITU-T G.982].

#### **9.2.8.4 Dispersion**

Systems considered limited by dispersion have maximum values of dispersion (ps/nm) specified in Table 9-3 and Table 9-4. These values are consistent with the maximum optical path penalties specified. They take into account the specified transmitter type, and the fibre dispersion coefficient over the operating wavelength range.

### **9.2.9 Receiver at $O_{rd}$ and $O_{lu}$**

All parameters are specified as follows, in accordance with Table 9-3 and Table 9-4.

#### **9.2.9.1 Receiver sensitivity**

Receiver sensitivity is defined in [ITU-T G.987]. The values are specified in Table 9-3 and Table 9-4. Receiver sensitivity takes into account power penalties caused by the use of a transmitter under standard operating conditions with worst-case values of ER, pulse rise and fall times, optical return loss (ORL) at point R/S, receiver connector degradation and measurement tolerances. The receiver sensitivity does not include power penalties associated with dispersion, jitter or reflections from the optical path; these effects are specified separately in the allocation of maximum OPP.

### 9.2.9.2 Receiver overload

Receiver overload is defined in [ITU-T G.987]. The values are specified in Table 9-3 and Table 9-4, accordingly. The receiver should have a certain robustness against increased optical power level due to start-up or potential collisions during ranging, for which the BER, specified in Table 9-3 and Table 9-4, is not guaranteed.

### 9.2.9.3 Maximum optical path penalty

Optical path penalty is defined in [ITU-T G.987]. The receiver is required to tolerate an OPP not exceeding the value specified in Table 9-3 and Table 9-4.

### 9.2.9.4 Maximum reflectance at R/S, measured at receiver wavelength

Reflections from equipment (ONU/OLT) back to the cable plant are specified by the maximum permissible reflectance of equipment measured at  $O_{rd}$  and  $O_{lu}$ . It shall be in accordance with Table 9-3 and Table 9-4.

### 9.2.9.5 Differential optical path loss

Differential optical path loss means the optical path loss difference between the highest and lowest optical path loss in the same ODN. The maximum differential optical path loss is defined in Table 9-3 and Table 9-4.

### 9.2.9.6 Clock extraction capability

NOTE – The clock of the upstream transmission signal is extracted rapidly from several alternating bits in the preamble. The clock extracted from the preamble is maintained at least during reception of the signal from the delimiter through the end of the upstream assigned burst, or is continuously extracted from the signal after the preamble during reception of the assigned burst.

### 9.2.9.7 Jitter performance

This clause deals with jitter requirements for optical interfaces of XG-PON.

#### 9.2.9.7.1 Jitter transfer

The jitter transfer specification applies only to the ONU.

The jitter transfer function is defined as:

$$jitter\ transfer = 20 \log_{10} \left[ \frac{jitter\ on\ upstream\ signal\ UI}{jitter\ on\ downstream\ signal\ UI} \times \frac{downstream\ bit\ rate}{upstream\ bit\ rate} \right]$$

The jitter transfer function of an ONU shall be under the curve given in Figure 9-6, when input sinusoidal jitter up to the mask level in Figure 9-7 is applied, with the parameters specified in this figure for each line rate.

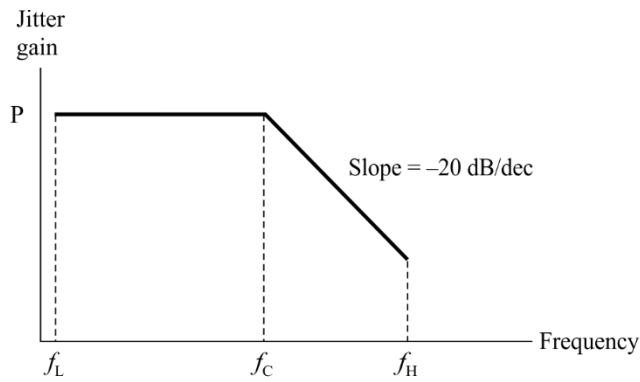

Upstream line rate (Gbit/s)	$f_L$ (kHz)	$f_C$ (kHz)	$f_H$ (kHz)	P (dB)
2.48832	20	2000	20'000	0.1

NOTE – These values are taken from [ITU-T G.783]

G.987.2(16)\_F9-6

**Figure 9-6 – Jitter transfer for ONU**

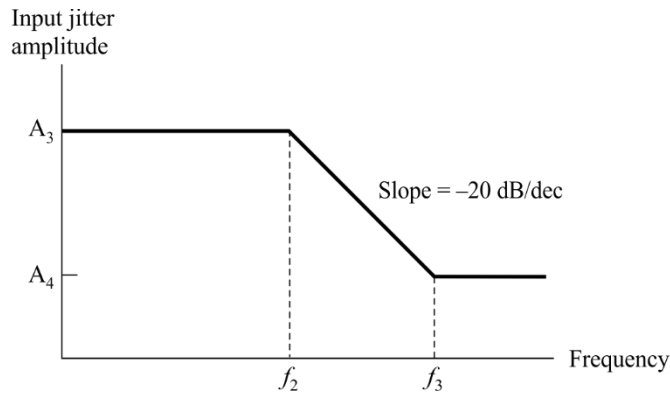

Downstream line rate (Gbit/s)	$A_3$ (UI)	$A_4$ (UI)	$f_2$ (kHz)	$f_3$ (kHz)
9.95328	1.5	0.15	400	4000

NOTE – These values are taken from [ITU-T G.783]

G.987.2(16)\_F9-7

**Figure 9-7 – High-band portion of sinusoidal jitter mask for jitter transfer**

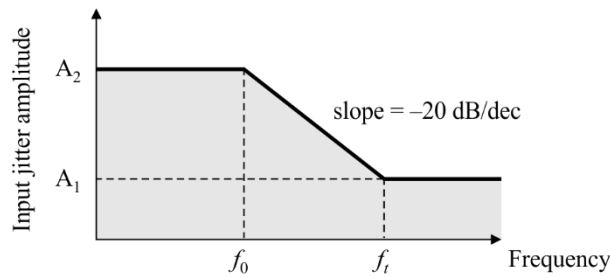

Line rate (Gbit/s)	$f_i$ [kHz]	$f_0$ [kHz]	$A_1$ [UIp-p]	$A_2$ [UIp-p]
2.48832	1000	100	0.075	0.75
9.95328	4000	400	0.075	0.75

NOTE – These values are scaled to 10 Gbit/s from the values in [ITU-T G.984.2]

G.987.2(16)\_F9-8

**Figure 9-8 – Jitter tolerance mask**

### 9.2.9.7.2 Jitter tolerance

Jitter tolerance is defined as the peak-to-peak amplitude of sinusoidal jitter applied on the input XG-PON signal that causes a 1 dB optical power penalty at the optical equipment. Note that it is a stress test to ensure that no additional penalty is incurred under operating conditions.

The ONU shall tolerate, as a minimum, the input jitter applied according to the mask in Figure 9-8, with the parameters specified in that figure for the downstream line rate. The OLT should tolerate, as a minimum, the input jitter applied according to the mask in Figure 9-8, with the parameters specified in that figure for the upstream line rate. The jitter tolerance specification for the OLT is informative as it can only be measured in a setting that permits continuous operation of the upstream.

### 9.2.9.7.3 Jitter generation

An ONU shall not generate a peak-to-peak jitter amplitude more than shown in Table 9-7 at a line rate of 2.48832 Gbit/s, with no jitter applied to the downstream input and with a measurement bandwidth as specified in Table 9-7. An OLT shall not generate a peak-to-peak jitter amplitude more than that shown in Table 9-7 at a line rate of 9.95328 Gbit/s, with no jitter applied to its timing reference input and with a measurement bandwidth as specified in Table 9-7.

**Table 9-7 – Jitter generation requirements for XG-PON**

Line rate (Gbit/s)	Measurement band (-3 dB frequencies) (Note 1)		Peak-peak amplitude (UI) (Note 2)
	High-pass (kHz)	Low-pass (MHz) -60 dB/dec	
2.48832	5	20	0.30
	1000	20	0.10
9.95328	20	80	0.30
	4000	80	0.10

NOTE 1 – The high-pass and low-pass measurement filter transfer functions are defined in clause 5 of [ITU-T G.825].

NOTE 2 – The measurement time and pass/fail criteria are defined in clause 5 of [ITU-T G.825].

NOTE 3 – This table comes from [ITU-T G.783].

### 9.2.9.8 Consecutive identical digit (CID) immunity

The OLT and the ONU shall have a CID immunity as specified in the series of Table 9-3 and Table 9-4.

### 9.2.9.9 Receiver tolerance to reflected power

The receiver tolerance to reflected power is the allowable ratio of optical input average power of  $O_{rd}$  and  $O_{lu}$  to reflected optical average power when multiple reflections are regarded as a noise light at  $O_{rd}$  and  $O_{lu}$ , respectively.

The receiver tolerance to reflected power is defined at minimum receiver sensitivity.

### 9.2.9.10 Transmission quality and error performance

To avoid system down time or failures, the frame structure should be robust in the presence of transmission BER up to the values defined in Table 9-3 and Table 9-4.

The average BER on individual links across the entire PON system will typically be lower than the values defined in Table 9-3 and Table 9-4. Optical components should provide BER better than the values defined in Table 9-3 and Table 9-4 when conditions allow.

## 10 X/S tolerance masks

### 10.1 X/S tolerance mask for ONU

The minimum optical sensitivity of an XG-PON ONU must be met in the presence of interference signals. Interference signals are caused by other services such as G-PON and/or video signals in the enhancement band specified in [ITU-T G.987.1]. To minimize the effect of interference signals, XG-PON ONUs need to isolate them using an appropriate wavelength blocking filter (WBF) and WDM filter. This Recommendation does not specify the isolation characteristics of the WBF and WDM filters directly, but specifies the X/S tolerance of the XG-PON ONU. Here, S is the optical power of the XG-PON signal, and X is that of the interference signal(s). Both are measured at the ONU reference point R/S, corresponding to the ONU reference point  $IF_{XGPON}$  specified in [ITU-T G.987.1].

The interference signal format for measuring X/S tolerance is a non-return-to-zero (NRZ) pseudo-random code with the same line rate as the XG-PON downstream signal or a lower line rate within the bandwidth of the XG-PON receiver.

This tolerance can be used to design a variety of WDM configurations at the ONU. It makes no definite assumption about additional services using the enhancement band specified in [ITU-T G.987.1]. Figure 10-1 shows the X/S tolerance mask that should not cause the XG-PON receiver to fail to meet its sensitivity requirements. Implementers need to specify the isolation characteristics of the WBF and WDM filters to obtain enough isolation of the interference signal(s). This allows the XG-PON sensitivity requirement to be met in the presence of this level of interference. The wavelengths and total optical launched power of additional services must fall beneath the mask of Figure 10-1 to allow coexistence with XG-PON.

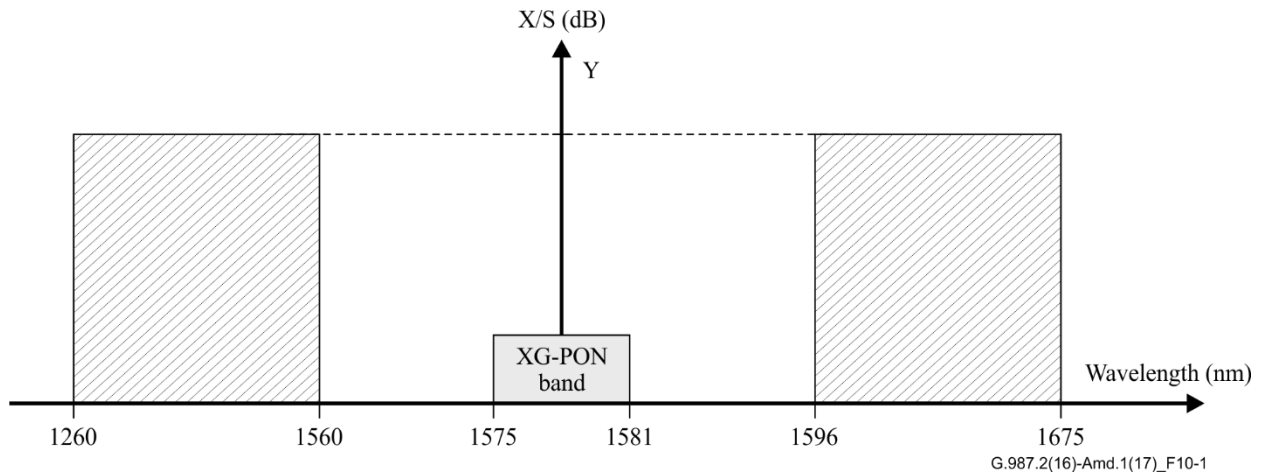

S: Received power of basic band

X: Maximum total power of additional services received in the blocking wavelength range.

X/S: In the mask (hatching area) should not cause the XG-PON receiver to fail to meet its sensitivity requirements.

**Figure 10-1 – X/S tolerance mask for ONU (Versatile WDM configuration)**

### 10.2 X/S tolerance mask for OLT

X/S tolerance mask definition of XG-PON OLT is used to enable a variety of WDM implementations at the OLT. This clause specifies the X/S tolerance mask that should ensure the XG-PON OLT receiver will not fail to meet its sensitivity requirements in the presence of coexisting PON signals. This is an optional requirement for an XG-PON OLT but, in order to facilitate smooth evolution to higher speed PON and alleviate the high isolation requirement of coexistence elements (CE<sub>x</sub>), it is recommended the necessary WBF be implemented. To ensure X/S compliance, implementers need to design the combined isolation characteristics of the WBF and WDM filters to obtain enough overall isolation of the signals in the blocking wavelength range. This allows the XG-PON OLT sensitivity requirement to be met in the presence of this level of interference.

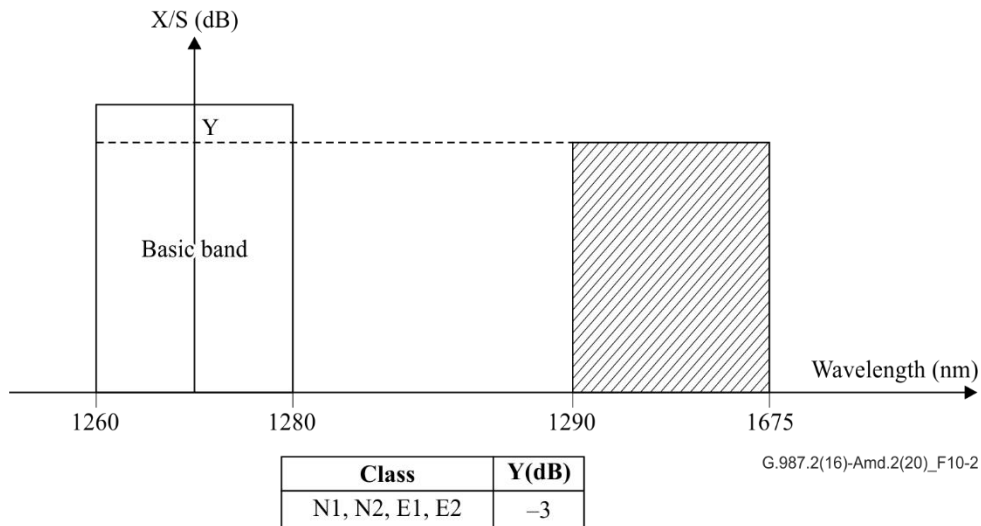

S: Received power.

X: Maximum total power of additional services received in the blocking wavelength range.

X/S: In the mask (hatching area) should not cause the XG-PON receiver to fail to meet its sensitivity requirements.

**Figure 10-2 – X/S tolerance mask for XG-PON OLT**



## 11 Upstream physical layer overhead

The XG-PON frame structure is described in [ITU-T G.987.3], which is devoted to the specification of the TC layer. However, upstream bursts must be preceded by suitable physical layer overhead, which is used to accommodate several physical processes. Table 11-1 shows the length of the physical layer overhead for the upstream line rate specified in this Recommendation.

**Table 11-1 – XG-PON upstream physical layer overhead**

<b>Upstream line rate</b>	<b>Overhead bits</b>
2.48832 Gbit/s	256

Moreover, Appendix III provides information on the physical processes that have to be performed during the physical layer overhead ( $T_{plo}$ ) time, and some guidelines on the optimum use of  $T_{plo}$ .

## Annex A

### ONU out-of-band power spectral density

(This annex forms an integral part of this Recommendation.)

The purpose of this annex is to specify a set of additional requirements on the ONU transmitter which should be applied in multisystem coexistence deployments. These requirements are stricter than those in the base text of this Recommendation.

The requirements specified in this annex are optional. Implementations of this Recommendation should not be assumed to meet the requirements of this annex. If the implementer declares the support of this annex, the implementation shall meet all the requirements specified herein.

Coexistence with other PON systems (e.g., ITU-T G.984.x Series, ITU-T G.989.x Series, ITU-T G.9804.3, etc.) on the same ODN is a frequent requirement for PON system deployments. In such cases, light from ONU transmitters of one PON type may fall into the upstream operating wavelength band of a coexisting PON system. If the optical power of this out-of-band (OOB) light is too high, then this may cause harmful crosstalk penalties on the upstream transmissions of the coexisting PON systems. Such problems are exacerbated in PON ODNs where the differential optical loss is high, and the interfering ONU is on a lower loss path.

To ensure successful operation in PON coexistence use cases, the out-of-band power spectral density (OOB-PSD) must be below a certain level. The OOB-PSD mask for the ONU transmitter at the R/S interface is shown in Figure A.1 and the values are given in Tables A.1 and A.2. To meet the OOB-PSD mask requirement, the ONU PSD remains below the dashed mask line under all operating conditions. The in-band power limit (Y) is the maximum ONU launched power and the points at the ONU operating band edge (Y-SMSR) represent the power limit given by the ONU transmitter side-mode-suppression ratio (SMSR). The out-of-band PSD (X) is the power outside of the ONU operating wavelength band that may fall into coexisting PON upstream operating wavelength bands. The OOB-PSD spectral interval is 0.1 nm according to the industry convention for optical signal-to-noise measurement.

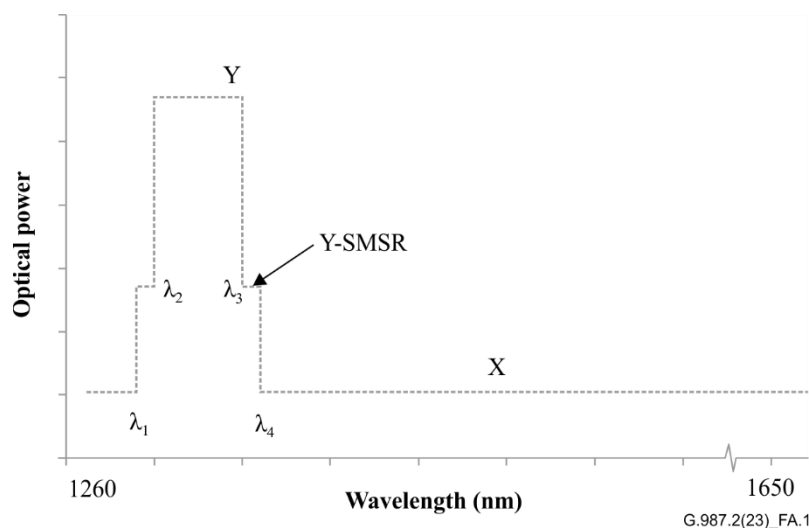

**Figure A.1 – ONU transmitter OOB-PSD mask definition**

**Table A.1 –ONU OOB-PSD mask wavelengths**

	<b>Wavelength (nm)</b>
$\lambda_1$	Not applicable
$\lambda_2$	1260
$\lambda_3$	1280
$\lambda_4$	1284

**Table A.2 – ONU OOB-PSD mask values**

<b>Mask range</b>	<b>PSD (dBm measured in 0.1 nm)</b>
$1260 \text{ nm} \leq \lambda < \lambda_1$	Not applicable
$\lambda_1 \leq \lambda < \lambda_2$	Y-SMSR
$\lambda_2 \leq \lambda \leq \lambda_3$	Y
$\lambda_3 < \lambda \leq \lambda_4$	Y-SMSR
$\lambda_4 < \lambda \leq 1650 \text{ nm}$	X= -41.5 dBm

Y= Mean launch power maximum as given in the ONU PMD parameter tables  
SMSR= Minimum side-mode-suppression ratio as given in the ONU PMD parameter tables.  
NOTE – The OOB-PSD mask specification must be met under the full range of ODN conditions including reflections, as specified elsewhere in this Recommendation.  
The mask wavelengths define the boundaries of measurement ranges. The entire 0.1 nm measurement interval should lie inside a single range.

## **Appendix I**

### **Examples of wavelength allocation for XG-PON, G-PON and video distribution services**

(This appendix does not form an integral part of this Recommendation.)

See Appendix II of [b-ITU-T G.984.5] for a generic consideration of wavelength allocation for XG-PON, G-PON and video distribution services.

## **Appendix II**

### **Physical layer measurements required to support optical layer supervision**

(This appendix does not form an integral part of this Recommendation.)

See Annex B in [ITU-T G.984.2].

## Appendix III

### Allocation of the physical layer overhead time

(This appendix does not form an integral part of this Recommendation.)

The physical layer overhead time ( $T_{plo}$ ) is used to accommodate five physical processes in the PON. These are: laser on/off time, timing drift tolerance, level recovery, clock recovery and start of burst delimitation. The exact division of the physical layer time to all these functions is determined partly by constraint equations and partly by implementation choices. This appendix reviews the constraints that the OLT must comply with, and suggests values for the discretionary values.

$T_{plo}$  can be divided into three sections with respect to what ONU data pattern is desired. For simplicity, these times can be referred to as the guard time ( $T_g$ ), the preamble time ( $T_p$ ) and the delimiter time ( $T_d$ ). During  $T_g$ , the ONU transmit levels are not specified, provided they comply with the PMD Tables 9-3 and 9-4. During the Tx disable bit period immediately following the assigned burst, the maximum launch power level allowed is the zero-level corresponding to the minimum ER specified in Tables 9-3 and 9-4. During  $T_p$ , the ONU will transmit a preamble pattern that provides the desired transition density and signal pattern for fast level and clock recovery functions. Lastly, during  $T_d$ , the ONU will transmit a special data pattern with optimal autocorrelation properties that enable the OLT to find the beginning of the burst. Table III.2 gives recommended values for  $T_g$ ,  $T_p$ ,  $T_d$  and  $T_{plo}$ . Figure III.1 shows the timing relationship between the various physical layer overhead times.

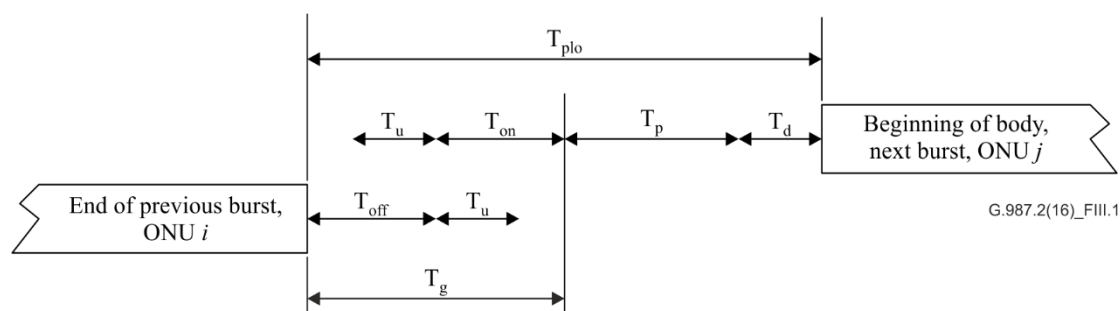

**Figure III.1 – Timing relationship between the various physical layer overhead times**

An additional parameter of the control logic on the PON is the total peak-to-peak timing uncertainty ( $T_u$ ). This uncertainty arises from variations of the time of flight caused by the fibre and component variations with temperature and other environmental factors.

The constraint equations with which the OLT must comply are then:

$$T_g > T_{on} + T_u \text{ and } T_g > T_{off} + T_u$$

These equations can be explained as follows. The first equation makes sure that the following burst's laser on ramp-up does not fall on top of the last burst's data. The second equation makes sure that the last burst's laser off tail-off does not fall on top of the following burst's preamble.

$T_p$  must be sufficient for the physical layer to recover the signal level (essentially, setting the decision threshold) and the signal clock phase. There are many diverse design approaches to these two problems, each with its own benefits and costs. Some designs are very fast, but require an external trigger signal and produce sub-optimal error performance. Other designs are slower, but do not require a reset signal and produce bit errors that are normally distributed. In addition, each of these designs may have special requirements on the data pattern used for the preamble. Some designs prefer a maximum transition density pattern, while others prefer a pattern with a balance of transitions and controlled runs of identical digits.

Since the design is up to the OLT implementer, the OLT is able to configure the details of the preamble that is transmitted by the ONU. This is part of the burst profile discussion below.

$T_d$  must be long enough to provide a robust delimiter function in the face of bit errors. The error resistance of the delimiter depends on the exact implementation of the pattern correlator, but a simple approximate relationship between the number of bits in the delimiter ( $N$ ) and the number of bit errors tolerated ( $E$ ) is:

$$E = \text{int}(N/4) - 1 \quad (\text{III.1})$$

Equation III.1 has been empirically verified by a numerical search of all delimiters of sizes ranging from 8 to 32 bits. This search was performed under the assumption that the preamble pattern was a '1010' repeating pattern, and that the delimiter had an equal number of zeroes and ones. The Hamming distance,  $D$ , of the best delimiter from all shifted patterns of itself and the preamble was found to be  $D = \text{int}(N/2) - 1$ ; yielding the error tolerance shown.

Given a certain BER, the probability of a severely errored burst ( $P_{seb}$ ) is given by:

$$P_{seb} = \binom{N}{E+1} BER^{E+1} \quad (\text{III.2})$$

Substituting equation III.1 into equation III.2, the resultant  $P_{seb}$  is given by:

$$P_{seb} = \binom{N}{\text{int}(N/4)} BER^{\text{int}(N/4)} \quad (\text{III.3})$$

If the BER equals  $10^{-4}$ , the resultant  $P_{seb}$  for various delimiter lengths,  $N$ , is given in Table III.1. Inspection of this table shows that, in order to effectively suppress this kind of error, the delimiter length must be at least 16 bits long. The choice of delimiter length and pattern is made by the OLT as part of the burst profile.

**Table III.1 – Probability of a severely errored burst as a function of delimiter length**

$N$	$P_{seb}$
8	$2.8 \times 10^{-7}$
12	$2.2 \times 10^{-10}$
16	$1.8 \times 10^{-13}$
20	$1.5 \times 10^{-16}$
24	$1.3 \times 10^{-19}$
32	$1.1 \times 10^{-25}$
64	$4.9 \times 10^{-50}$

With these considerations taken into account, the worst case and objective allocations of the physical layer overhead are given in Table III.2. This table also lists the values for the ONU Tx enable time and Tx disable time, and the total physical layer overhead time for reference. The worst-case values are intended to provide a reasonable bound for easy implementation, and the objective values are intended to be the design target for more efficient implementation with optimized components. These values are for a simple ODN without reach extenders. Reach extenders may require their own guard and preamble time allowances, making the total overhead larger.

**Table III.2 – Recommended allocation of burst mode overhead time for XG-PON OLT functions**

	<b>Tx enable</b>	<b>Tx disable</b>	<b>Total time</b>	<b>Guard time</b>	<b>Preamble time</b>	<b>Delimiter time</b>
Worst case (bit times)	32	32	2048	128	1856	64
Objective (bit times)	32	32	256	64	160	32

In addition to the design dependent aspects of the burst overhead, there can be operationally dependent factors. For example, detecting an ONU's ranging burst is a more difficult problem than receiving an ONU's regular transmission. To consider another example, some ONUs may have higher power and be easier to detect, and therefore do not need forward error correction (FEC). For these reasons, the OLT may request different burst parameters depending on the context.

The concept of a burst profile captures all the aspects of burst overhead control. A burst profile specifies the preamble pattern and length, the delimiter pattern and length, and whether FEC parity should be sent. The OLT establishes one or more burst profiles, and then requests a particular burst profile for each burst transmission.

The OLT has considerable latitude in setting up the profiles, because the OLT's burst receiver is sensitive to the profile parameters. Therefore, the OLT should use profiles that ensure adequate response in its burst mode receiver. However, some basic requirements from the ONU side must be met. Namely, the preamble and delimiter patterns should be balanced, and they should have a reasonable transition density. If not, the ONU transmitter driver circuitry may be adversely affected. Also note that the preamble and delimiter patterns could differ in each profile, and this difference could be used by the OLT receiver as an in-band indication of the format of each burst (e.g., FEC active or not).

The details of distributing the burst profiles and signalling their use are described in [ITU-T G.987.3], the XG-PON XGTC layer.



## Appendix IV

### Jitter budget specifications

(This appendix does not form an integral part of this Recommendation.)

#### IV.1 The concept of jitter budget

Figure IV.1 describes the overall concept of the jitter specification and shows the place of the jitter budget in it.

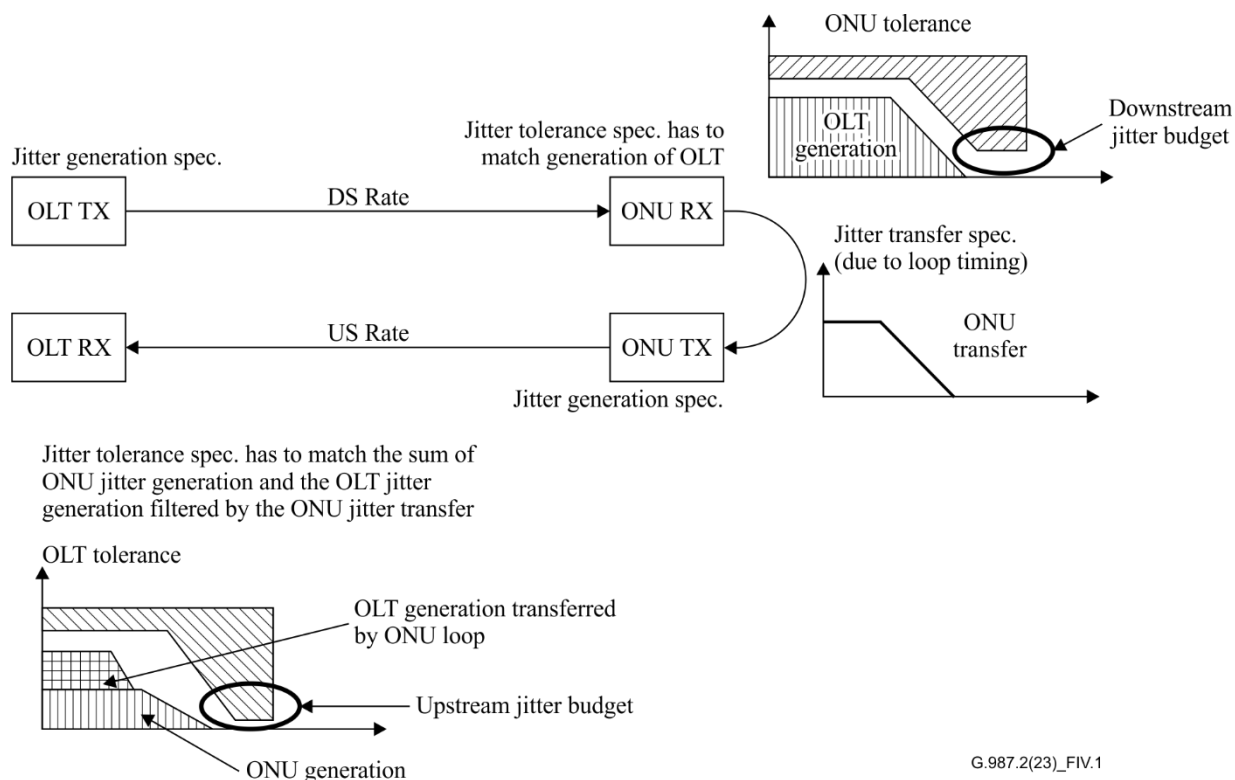

**Figure IV.1 – The place of the jitter budget in the overall jitter specification**

The jitter budget specifies jitter components that are not covered by the low frequency jitter specifications. All jitter components accounted for in the jitter budget are integrated over the frequency domain that starts from the upper corner frequency ( $f_i$ ) of the jitter tolerance mask (see clause 9.2.9.7.2).

The jitter budget is based on the dual Gaussian jitter model. In this model, the jitter components are classified into deterministic jitter (DJ) and random jitter (RJ). The DJ components are modelled as a bimodal distribution and the RJ components as a Gaussian distribution. In addition, the duty-cycle distortion (DCD), which is a DC component, is included into the DJ specification of the jitter budget. The basic assumptions of the model are as follows:

- 1) Jitter is represented assuming the DJ has an equiprobable bimodal distribution, and the RJ has a Gaussian distribution.
- 2) All sources of random jitter are assumed independent; therefore, RJ RMS values can be added by squares.
- 3) All sources of DJ are assumed to be correlated (this is a worst-case assumption, meaning that all DJ components are either together at maximum value or together at minimum value, with equal probability for the minimum and the maximum to occur).

Under these assumptions, the total jitter is defined at each given BER by:

$$TJ_{@BER} = DJ + RJ_{RMS} \cdot 2 \cdot Q^{-1}(BER)$$

where  $Q^{-1}(BER)$  is the inverse of the  $Q$  function. For a very rigorous definition of jitter methodologies, refer to [b-ISO MJSQ].

## IV.2 Definition of test points

In order to build a consistent jitter budget, test points need to be defined at which the jitter components are to be measured. It is important to notice that between the optical module and the SERDES component (whether it is a stand-alone component connected to the MAC through a parallel interface or whether it is integrated inside the MAC ASIC) there is a non-negligible electrical channel.

The test points of the jitter budget are defined in Figure IV.2 and Table IV.1.

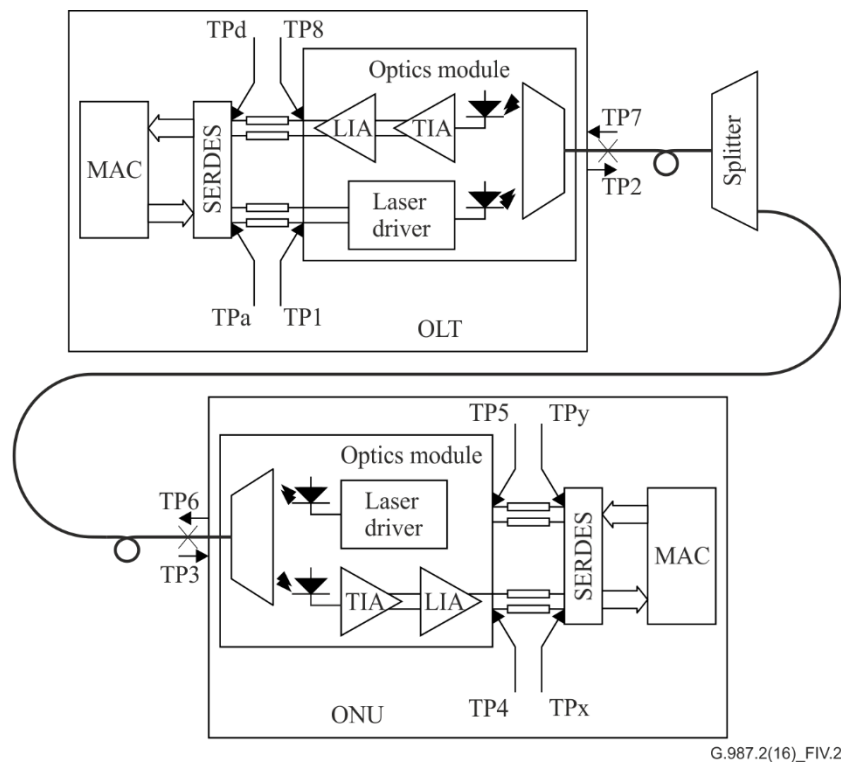

**Figure IV.2 – Test points of the jitter budget**

**Table IV.1 – Description of test points for jitter budget**

Test Point	Description
TPa	Electrical test point at the TX output pins of OLT SERDES
TP1	Electrical test point at the TX input pins of OLT optical module
TP2	Optical test point at output of OLT (downstream)
TP3	Optical test point at input of ONU (downstream)
TP4	Electrical test point at the RX output pins of ONU optical module
TPx	Electrical test point at the RX input pins of ONU SERDES
Tpy	Electrical test point at the TX output pins of ONU SERDES
TP5	Electrical test point at the TX input pins of ONU optical module
TP6	Optical test point at output of ONU (upstream)

**Table IV.1 – Description of test points for jitter budget**

Test Point	Description
TP7	Optical test point at input of OLT (upstream)
TP8	Electrical test point at the RX output pins of OLT optical module
TPd	Electrical test point at the RX input pins of OLT SERDES

### IV.3 Jitter budget specification for XG-PON

The proposed values of the jitter components at the different test points are presented in Table IV.2.

All jitter values are indicated as peak-to-peak values at the BER that corresponds to the respective test point. Jitter at all test points except TP4, TPx, TP8 and TPd is defined at BER =  $10^{-12}$ , which is the target BER of the system and also the default BER used by the test instruments. RJ at the receiver is calculated at a power level equal to the sum of the minimum sensitivity and the maximum OPP, as defined in Table 9-3 for the downstream direction and Table 9-4 for the upstream direction. Jitter at TP4 and TPx is defined at BER =  $10^{-3}$ , and jitter at TP8 and TPd is defined at BER= $10^{-4}$ , since the system relies on FEC to reach the system target BER.

**Table IV.2 – Jitter budget for XG-PON**

Downstream jitter budget				
Test point	DJ [Uipp]	RJ [Uipp]	TJ [Uipp]	BER
Tpa	0.10	0.14	0.24	$10^{-12}$
TP1	0.12	0.14	0.26	
TP2	0.21	0.18	0.38	
TP3	0.26	0.18	0.43	
TP4	0.41	0.27	0.67	$10^{-3}$
TPx	0.50	0.27	0.77	
Upstream jitter budget				
Test point	DJ [Uipp]	RJ [Uipp]	TJ [Uipp]	BER
Tpy	0.07	0.09	0.17	$10^{-12}$
TP5	0.10	0.09	0.20	
TP6	0.24	0.10	0.35	
TP7	0.24	0.10	0.35	
TP8	0.40	0.19	0.59	$10^{-4}$
TPd	0.43	0.19	0.62	
NOTE – The values in Table IV.2 are for further study and subject to change.				

### IV.4 Jitter measurements for compliance to budget

A set-up that can be used to measure the jitter components at the test points defined in Table IV.1 and verify their compliance to the values given in Table IV.2 is presented in Figure IV.3.

The set-up contains an OLT and an ONU. The ONU is configured to transmit in continuous mode and a PRBS31 pattern is recommended.

If measurement of jitter at optical test points is required, optical splitters have to be added to the set-up to permit connection of the O2E probe. If the measurement is to include the dispersion from the optical fibre, then a 20 km spool has to be added to the set-up.

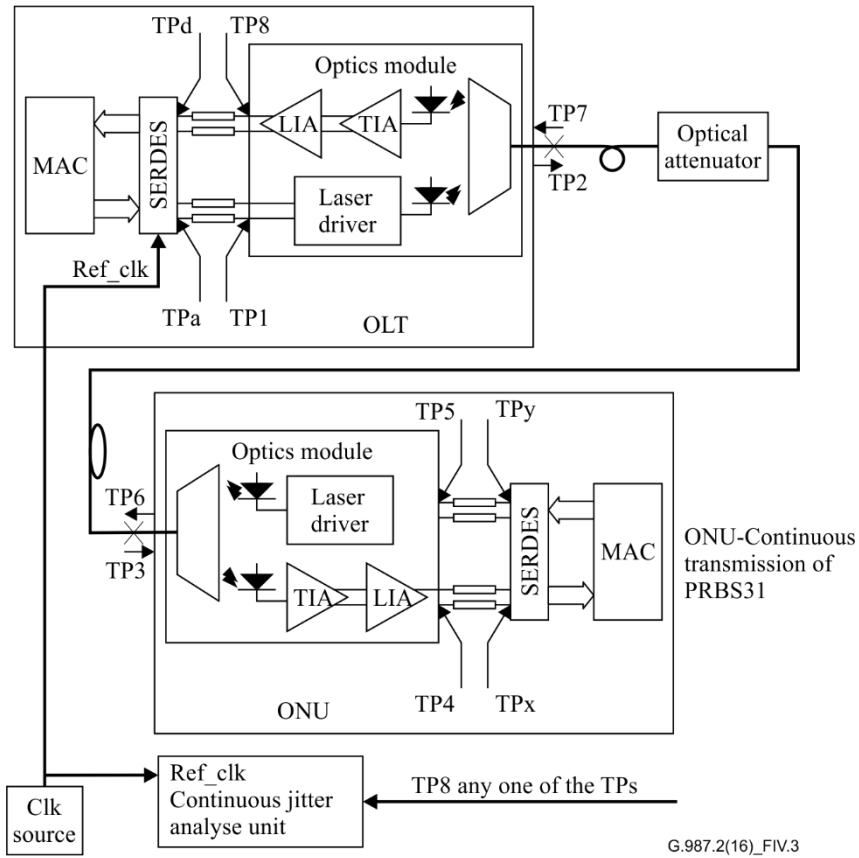

**Figure IV.3 – Measurement set-up for jitter budget compliance**

## Appendix V

### Measurement of burst mode acquisition time and burst mode eye opening at OLT

(This appendix does not form an integral part of this Recommendation.)

One of the major challenges for the burst mode clock and data recovery (CDR) implementation is the need to cope with the transient effects causing additional eye closure at the beginning of the burst. The burst mode CDR has to acquire the phase information exactly on the preamble portion of the incoming data stream, hence it would be reasonable to require the optical module to preserve signal good quality. The better the performance of the optics, the shorter the preamble required for correct system operation.

We define the burst mode eye opening as the opening of the eye pattern that is collected starting from an offset  $X$  from the beginning of the burst. The burst mode acquisition time is defined as the shortest offset  $X$  from the beginning of the burst that will render a compliant eye pattern. A compliant eye pattern means an eye opening that meets the jitter budget and correct logical signal levels.

A set-up for measuring burst mode acquisition time and burst mode eye opening occurring at the beginning of each burst is presented in Figure V.1.

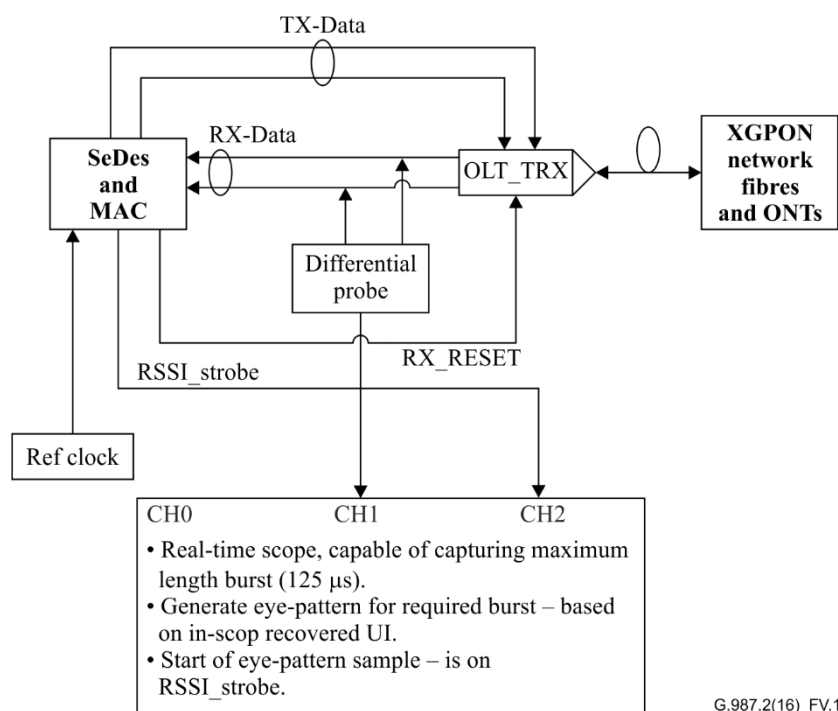
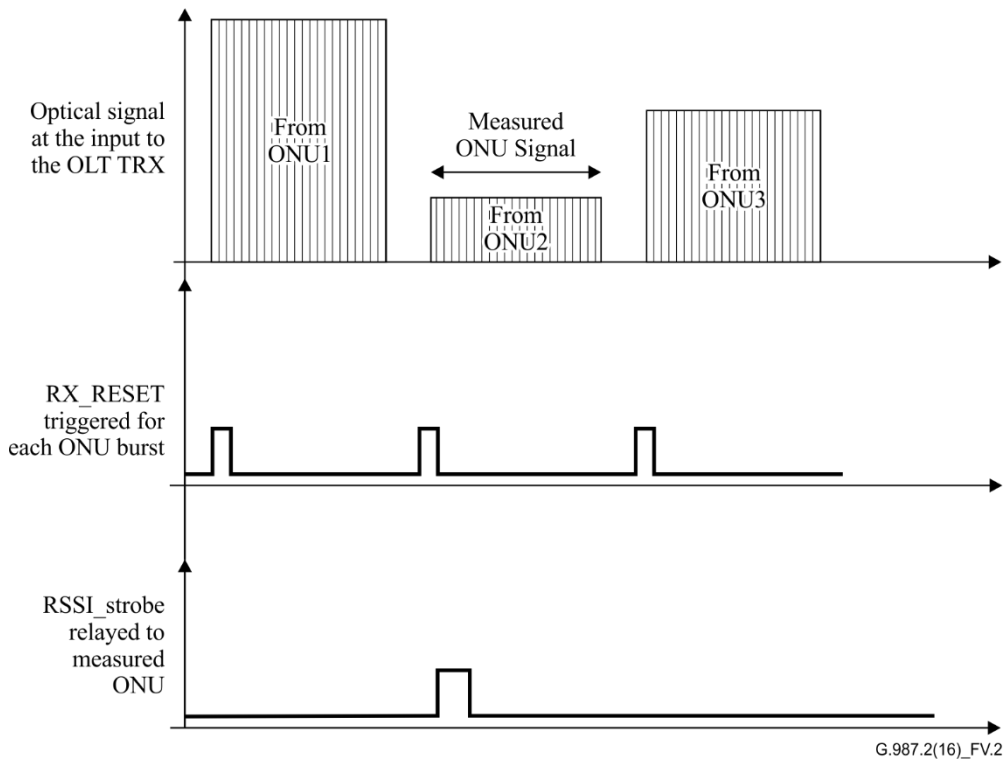

**Figure V.1 – Set-up for measurement of burst mode acquisition time and burst mode eye opening**

The following is a list of recommendations related to measurement of burst mode acquisition time and burst mode eye opening compliance:

- Use a real time sampling scope capable of 40 GS/s or more and a memory depth that can cover at least 125  $\mu$ s (5M samples) for capturing the eye pattern.
- In order to separate the eye pattern that corresponds to a single given ONU, the oscilloscope is triggered on RSSI-strobe signal [b-ITU-T G Suppl. 48]. The timing diagram for this signal is presented in Figure V.2.

- The burst mode eye diagram is built from the data collected during the sampling window defined in Figure V.3.
- The eye pattern is built using a unit interval (UI) based on an average unit interval (UI) calculated from the collected data.
- The differential probe can be placed to perform measurement at either TP8 (module pins) or at TPd (SERDES pins) (see Figure IV.2).
- The pass/fail condition should be a burst mode eye opening in excess of 0.38 UI at TPd and correct logical signal levels. Note that 0.38 UI is equal to  $(1 - T_J)$  for test point TPd in Table IV.2.



**Figure V.2 – RSSI\_strobe timing relative to selected burst source**

The test set-up shown in Figure V.1 can be used to determine the burst mode acquisition time of a given set of optics. The eye pattern measurement is repeated for different values of the parameter X (defined in Figure V.3) and the minimum setting of X for which the (horizontal) burst mode eye opening at TPd is better than 0.38 UI determines the burst mode acquisition time of the system. Note that 0.38 UI is equal to  $(1 - T_J)$  for test point TPd in Table IV.2.

The system will perform correctly for settings of the preamble length that are longer than the burst mode acquisition time.

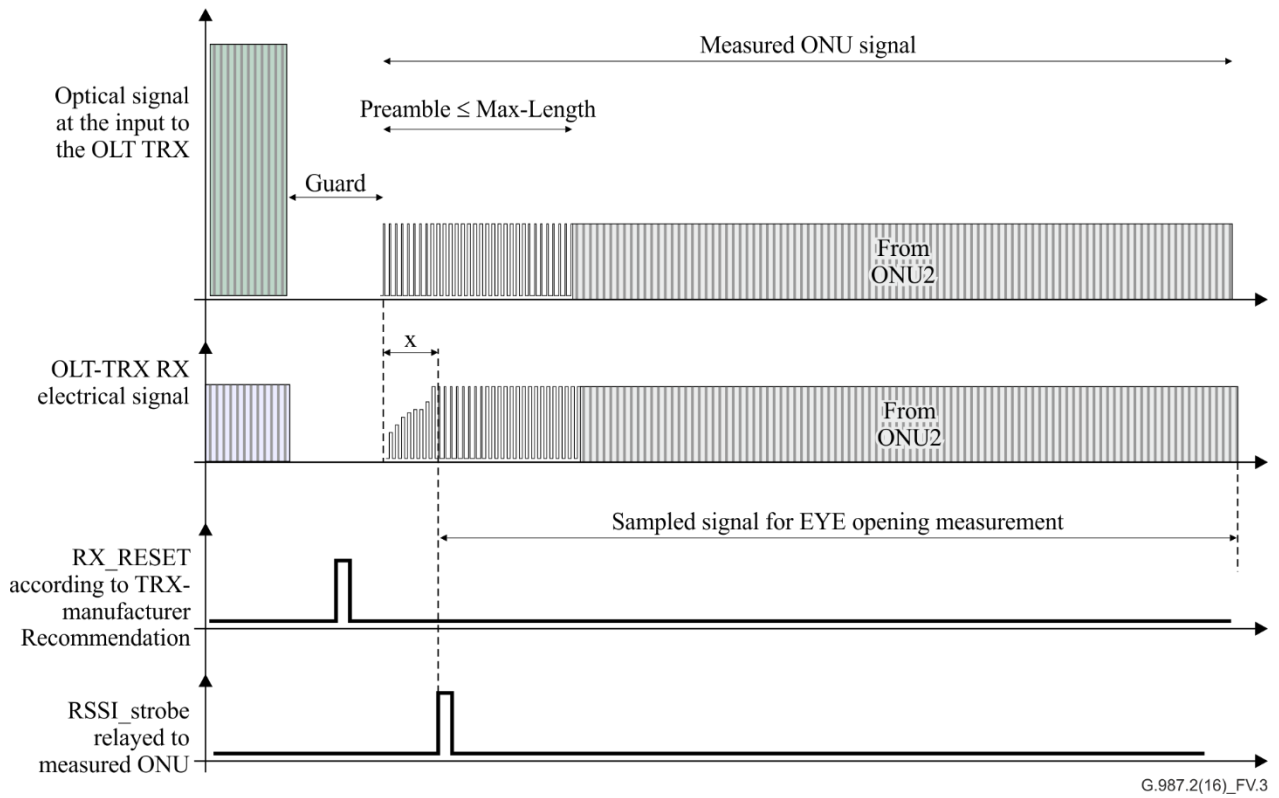

**Figure V.3 – Timing diagram of the sampling window for burst mode acquisition time and burst mode eye opening measurements**

## Bibliography

- [b-ITU-T G.983.1] Recommendation ITU-T G.983.1 (2005), *Broadband optical access systems based on passive optical networks (PON)*.
- [b-ITU-T G.984.5] Recommendation ITU-T G.984.5 (2022), *Gigabit-capable passive optical networks (G-PON): Enhancement band*.
- [b-ITU-T G Suppl.39] ITU-T G-series Recommendations – Supplement 39 (2016), *Optical system design and engineering considerations*.
- [b-ITU-T G Suppl. 48] ITU-T G-series Recommendations – Supplement 48 (2010), *10-Gigabit-capable passive optical networks: Interface between media access control with serializer/deserializer and physical medium dependent sublayers*.
- [b-ISO MJSQ] ISO/IEC TR 14165-117:2007, *Information technology – Fibre Channel – Part 117: Methodologies for jitter and signal quality (MJSQ)*.  
<<https://www.iso.org/standard/42706.htm>>.





## SERIES OF ITU-T RECOMMENDATIONS

Series A	Organization of the work of ITU-T
Series D	Tariff and accounting principles and international telecommunication/ICT economic and policy issues
Series E	Overall network operation, telephone service, service operation and human factors
Series F	Non-telephone telecommunication services
<b>Series G</b>	<b>Transmission systems and media, digital systems and networks</b>
Series H	Audiovisual and multimedia systems
Series I	Integrated services digital network
Series J	Cable networks and transmission of television, sound programme and other multimedia signals
Series K	Protection against interference
Series L	Environment and ICTs, climate change, e-waste, energy efficiency; construction, installation and protection of cables and other elements of outside plant
Series M	Telecommunication management, including TMN and network maintenance
Series N	Maintenance: international sound programme and television transmission circuits
Series O	Specifications of measuring equipment
Series P	Telephone transmission quality, telephone installations, local line networks
Series Q	Switching and signalling, and associated measurements and tests
Series R	Telegraph transmission
Series S	Telegraph services terminal equipment
Series T	Terminals for telematic services
Series U	Telegraph switching
Series V	Data communication over the telephone network
Series X	Data networks, open system communications and security
Series Y	Global information infrastructure, Internet protocol aspects, next-generation networks, Internet of Things and smart cities
Series Z	Languages and general software aspects for telecommunication systems