

International Telecommunication Union

ITU-T

TELECOMMUNICATION
STANDARDIZATION SECTOR
OF ITU

G.993.2
Amendment 2
(03/2016)

SERIES G: TRANSMISSION SYSTEMS AND MEDIA,
DIGITAL SYSTEMS AND NETWORKS

Digital sections and digital line system – Metallic access
networks

Very high speed digital subscriber line
transceivers 2 (VDSL2)

Amendment 2

Recommendation ITU-T G.993.2 (2015) –
Amendment 2

ITU-T



ITU-T G-SERIES RECOMMENDATIONS

TRANSMISSION SYSTEMS AND MEDIA, DIGITAL SYSTEMS AND NETWORKS

INTERNATIONAL TELEPHONE CONNECTIONS AND CIRCUITS	G.100–G.199
GENERAL CHARACTERISTICS COMMON TO ALL ANALOGUE CARRIER-TRANSMISSION SYSTEMS	G.200–G.299
INDIVIDUAL CHARACTERISTICS OF INTERNATIONAL CARRIER TELEPHONE SYSTEMS ON METALLIC LINES	G.300–G.399
GENERAL CHARACTERISTICS OF INTERNATIONAL CARRIER TELEPHONE SYSTEMS ON RADIO-RELAY OR SATELLITE LINKS AND INTERCONNECTION WITH METALLIC LINES	G.400–G.449
COORDINATION OF RADIOTELEPHONY AND LINE TELEPHONY	G.450–G.499
TRANSMISSION MEDIA AND OPTICAL SYSTEMS CHARACTERISTICS	G.600–G.699
DIGITAL TERMINAL EQUIPMENTS	G.700–G.799
DIGITAL NETWORKS	G.800–G.899
DIGITAL SECTIONS AND DIGITAL LINE SYSTEM	G.900–G.999
General	G.900–G.909
Parameters for optical fibre cable systems	G.910–G.919
Digital sections at hierarchical bit rates based on a bit rate of 2048 kbit/s	G.920–G.929
Digital line transmission systems on cable at non-hierarchical bit rates	G.930–G.939
Digital line systems provided by FDM transmission bearers	G.940–G.949
Digital line systems	G.950–G.959
Digital section and digital transmission systems for customer access to ISDN	G.960–G.969
Optical fibre submarine cable systems	G.970–G.979
Optical line systems for local and access networks	G.980–G.989
Metallic access networks	G.990–G.999
MULTIMEDIA QUALITY OF SERVICE AND PERFORMANCE – GENERIC AND USER-RELATED ASPECTS	G.1000–G.1999
TRANSMISSION MEDIA CHARACTERISTICS	G.6000–G.6999
DATA OVER TRANSPORT – GENERIC ASPECTS	G.7000–G.7999
PACKET OVER TRANSPORT ASPECTS	G.8000–G.8999
ACCESS NETWORKS	G.9000–G.9999

For further details, please refer to the list of ITU-T Recommendations.

Recommendation ITU-T G.993.2

Very high speed digital subscriber line transceivers 2 (VDSL2)

Amendment 2

Summary

Recommendation ITU-T G.993.2 specifies an access technology that exploits the existing infrastructure of copper wires that were originally deployed for POTS services. It can be deployed from central offices, from fibre-fed cabinets located near customer premises, or within buildings. This Recommendation is an enhancement to ITU T G.993.1 that supports asymmetric and symmetric transmission at a bidirectional net data rate up to 200 Mbit/s on twisted pairs using a bandwidth up to 30 MHz.

This version of this Recommendation integrates all the previous amendments and corrigenda with the 2011 version of Recommendation ITU-T G.993.2.

Amendment 2 to Recommendation ITU-T G.993.2 (2015) defines the new functionality:

- Method to address the misestimation of the SNR during MEDLEY.

History

Edition	Recommendation	Approval	Study Group	Unique ID*
1.0	ITU-T G.993.2	2006-02-17	15	11.1002/1000/8548
1.1	ITU-T G.993.2 (2006) Cor. 1	2006-12-14	15	11.1002/1000/8992
1.2	ITU-T G.993.2 (2006) Amd. 1	2007-04-06	15	11.1002/1000/8991
1.3	ITU-T G.993.2 (2006) Amd. 1 Cor. 1	2007-07-29	15	11.1002/1000/9164
1.4	ITU-T G.993.2 (2006) Cor. 2	2007-07-29	15	11.1002/1000/9166
1.5	ITU-T G.993.2 (2006) Amd. 2	2008-02-06	15	11.1002/1000/9165
1.6	ITU-T G.993.2 (2006) Amd. 3	2008-08-22	15	11.1002/1000/9387
1.7	ITU-T G.993.2 (2006) Amd. 4	2009-01-13	15	11.1002/1000/9654
1.8	ITU-T G.993.2 (2006) Cor. 3	2009-06-29	15	11.1002/1000/9890
1.9	ITU-T G.993.2 (2006) Amd. 5	2010-04-22	15	11.1002/1000/10413
1.10	ITU-T G.993.2 (2006) Amd. 6	2010-11-29	15	11.1002/1000/11022
1.11	ITU-T G.993.2 (2006) Cor. 4	2011-04-13	15	11.1002/1000/11149
1.12	ITU-T G.993.2 (2006) Amd. 7	2011-06-22	15	11.1002/1000/11148
2.0	ITU-T G.993.2	2011-12-16	15	11.1002/1000/11415
2.1	ITU-T G.993.2 (2011) Amd. 1	2012-04-06	15	11.1002/1000/11502
2.2	ITU-T G.993.2 (2011) Cor. 1	2012-06-13	15	11.1002/1000/11642
2.3	ITU-T G.993.2 (2011) Amd. 2	2012-12-07	15	11.1002/1000/11795
2.4	ITU-T G.993.2 (2011) Amd. 3	2013-04-22	15	11.1002/1000/11888
2.5	ITU-T G.993.2 (2011) Amd. 4	2013-08-29	15	11.1002/1000/11992
2.6	ITU-T G.993.2 (2011) Amd. 5	2014-01-13	15	11.1002/1000/12096
2.7	ITU-T G.993.2 (2011) Amd. 6	2015-05-22	15	11.1002/1000/12371
3.0	ITU-T G.993.2	2015-01-13	15	11.1002/1000/12370
3.1	ITU-T G.993.2 (2015) Amd. 1	2015-11-06	15	11.1002/1000/12563
3.2	ITU-T G.993.2 (2015) Amd. 2	2016-03-29	15	11.1002/1000/12796

* To access the Recommendation, type the URL <http://handle.itu.int/> in the address field of your web browser, followed by the Recommendation's unique ID. For example, <http://handle.itu.int/11.1002/1000/11830-en>.

FOREWORD

The International Telecommunication Union (ITU) is the United Nations specialized agency in the field of telecommunications, information and communication technologies (ICTs). The ITU Telecommunication Standardization Sector (ITU-T) is a permanent organ of ITU. ITU-T is responsible for studying technical, operating and tariff questions and issuing Recommendations on them with a view to standardizing telecommunications on a worldwide basis.

The World Telecommunication Standardization Assembly (WTSA), which meets every four years, establishes the topics for study by the ITU-T study groups which, in turn, produce Recommendations on these topics.

The approval of ITU-T Recommendations is covered by the procedure laid down in WTSA Resolution 1.

In some areas of information technology which fall within ITU-T's purview, the necessary standards are prepared on a collaborative basis with ISO and IEC.

NOTE

In this Recommendation, the expression "Administration" is used for conciseness to indicate both a telecommunication administration and a recognized operating agency.

Compliance with this Recommendation is voluntary. However, the Recommendation may contain certain mandatory provisions (to ensure, e.g., interoperability or applicability) and compliance with the Recommendation is achieved when all of these mandatory provisions are met. The words "shall" or some other obligatory language such as "must" and the negative equivalents are used to express requirements. The use of such words does not suggest that compliance with the Recommendation is required of any party.

INTELLECTUAL PROPERTY RIGHTS

ITU draws attention to the possibility that the practice or implementation of this Recommendation may involve the use of a claimed Intellectual Property Right. ITU takes no position concerning the evidence, validity or applicability of claimed Intellectual Property Rights, whether asserted by ITU members or others outside of the Recommendation development process.

As of the date of approval of this Recommendation, ITU had received notice of intellectual property, protected by patents, which may be required to implement this Recommendation. However, implementers are cautioned that this may not represent the latest information and are therefore strongly urged to consult the TSB patent database at <http://www.itu.int/ITU-T/ipr/>.

© ITU 2016

All rights reserved. No part of this publication may be reproduced, by any means whatsoever, without the prior written permission of ITU.

Table of Contents

	Page
1	Scope..... 1
2	References..... 3
3	Definitions 4
4	Abbreviations and acronyms 8
5	Reference models..... 11
5.1	VTU functional model..... 11
5.2	User plane protocol reference model..... 13
5.3	Management plane reference model..... 14
5.4	Application reference models..... 15
6	Profiles..... 19
6.1	Definition..... 19
6.2	Profile parameter definitions 23
6.3	Profile compliance..... 26
7	Transmission medium interface characteristics..... 27
7.1	Duplexing method and band plan construction..... 27
7.2	Power spectral density (PSD)..... 28
7.3	Termination impedance 44
7.4	Longitudinal conversion loss..... 44
8	Transport protocol specific transmission convergence (TPS-TC) function 45
8.1	The user data TPS-TC 45
8.2	Management TPS-TC (MPS-TC)..... 47
8.3	Network timing reference TPS-TC (NTR-TC) 51
8.4	Time-of-day TPS-TC (ToD-TC) 52
9	Physical media specific transmission convergence (PMS-TC) sublayer 59
9.1	PMS-TC functional model 59
9.2	Scrambler..... 63
9.3	Forward error correction..... 63
9.4	Interleaving..... 64
9.5	Framing..... 66
9.6	Impulse noise protection (INP_p) 75
9.7	Delay..... 76
9.8	Bit error ratio (BER)..... 77
9.9	Delay variation 77
10	Physical media dependent (PMD) function..... 77
10.1	PMD functional model 77
10.2	DMT superframe 78

	Page
10.3	Symbol encoder for data symbols 79
10.4	Modulation 93
10.5	Symbol encoder for sync symbol 97
10.6	Symbol encoder for initialization 97
11	Operation and maintenance (OAM) 98
11.1	OAM functional model..... 98
11.2	VDSL2 management entity (VME)..... 100
11.3	OAM primitives..... 135
11.4	OAM parameters 138
11.5	Data gathering function 173
12	Link activation methods and procedures 185
12.1	Overview 185
12.2	Special operations channel (SOC)..... 193
12.3	Initialization procedure..... 197
12.4	Loop diagnostic mode procedures 287
12.5	Fast start-up 296
13	On-line reconfiguration (OLR)..... 296
13.1	Types of on-line reconfiguration 296
13.2	Control parameters 297
13.3	Timing of changes in subcarrier configuration 299
13.4	Receiver initiated procedure..... 301
14	Electrical requirements 304
14.1	Termination impedance model 304
14.2	Service splitters 304
Annex A – Region A (North America).....	306
A.1	Band plan..... 306
A.2	Limit PSD masks 306
A.3	UPBO reference PSDs..... 314
Annex B – Region B (Europe).....	315
B.1	Band plans 315
B.2	Limit PSD mask options..... 318
B.3	UPBO reference PSDs..... 334
B.4	Template PSD..... 334
B.5	Compliance..... 334
Annex C – Region C (Japan)	335
C.1	Band plan..... 335
C.2	Limit PSD masks 335
C.3	VDSL2 system with PSD reduction at frequencies below DPBOFMAX..... 344
C.4	Upstream power back-off (UPBO) PSD masks 344

	Page
C.5 Service Splitter	345
C.6 Test loops and crosstalk disturbers.....	345
Annex D	347
Annex E	347
Annex F	347
Annex G	347
Annex H	347
Annex J	347
Annex K	347
Annex L – TPS-TC functional descriptions.....	348
L.1 STM transmission convergence (STM-TC) function.....	348
L.2 ATM transmission convergence (ATM-TC) function	354
L.3 Packet transmission convergence function (PTM-TC)	364
Annex M – Time-of-day distribution over VDSL2 links	370
M.1 Time-of-day distribution operational overview.....	370
M.2 Definitions	370
M.3 Abbreviations	370
M.4 VTU functional model.....	370
M.5 TPS-TC function	370
M.6 eoc communication protocol	370
M.7 ToD TPS-TC (ToD-TC)	370
M.8 Mapping of OH data.....	370
M.9 eoc transmission protocol.....	370
M.10 Frequency synchronization command.....	370
M.11 Time synchronization command and responses	372
M.12 Updates to initialization.....	372
Annex N – Region D (China)	373
N.1 Band plans	373
N.2 Limit PSD mask options.....	375
Annex O	380
Annex P – Short reach VDSL2 with reduced power and enhanced data rate.....	381
P.1 Scope	381
P.2 Reduced ATP.....	381
P.3 Minimum bidirectional net data rate capability.....	381
P.4 ITU-T G.998.4 Annex D support for enhanced net data rates with ITU-T G.998.4	381
P.5 SRA support	382
P.6 TPS-TC.....	382

	Page
Annex Q – Enhanced data rate 35 MHz VDSL2 with 4.3125 kHz subcarrier spacing	383
Q.1 Scope	383
Q.2 Capabilities related to the profile	383
Q.3 ITU-T G.998.4 Annex D support for enhanced net data rates	384
Q.4 SRA support	385
Q.5 TPS-TC.....	386
Q.6 Additional changes to ITU-T G.993.2 for operation according to profile 35b	386
Annex R	400
Annex S	400
Annex T	400
Annex U	400
Annex V	400
Annex W	400
Annex X – ITU-T G.993.5-friendly ITU-T G.993.2 operation in the downstream direction..	401
X.1 Power management commands and responses (clause 11.2.3.9)	401
X.2 Initialization procedure (supplements clause 12.3)	402
Annex Y – Full ITU-T G.993.5-friendly ITU-T G.993.2 operation	409
Y.1 Initialization procedure (supplements clause 12.3)	409
Y.2 R-MSG1 (supplements clause 10.3.2.2 of [ITU-T G.993.5])	412
Y.3 O-TA_UPDATE (supplements clause 10.4.2.1 of [ITU-T G.993.5]).....	412
Y.4 R-P-VECTOR 2 (replaces clause 10.4.4.5 of [ITU-T G.993.5])	412
Y.5 O-PMS (supplements clause 10.5.2.1 of [ITU-T G.993.5]).....	413
Y.6 eoc messages for backchannel configuration (replaces clause 8.1 of [ITU-T G.993.5]).....	413
Y.7 Loop diagnostic mode procedures (replaces clause 12.4)	413
Appendix I – Example values of DPBO parameters to protect ADSL2plus for clause C.3	414
I.1 Example PSD parameters	414
I.2 Example Cable parameters	414
I.3 Example frequency parameters	415
Appendix II – Impact of loop and VTU impedance mismatch on the Hlog accuracy.....	416
Bibliography.....	419

Recommendation ITU-T G.993.2

Very high speed digital subscriber line transceivers 2 (VDSL2)

Amendment 2

Editorial note: This is a complete-text publication. Modifications introduced by this amendment are shown in revision marks relative to Recommendation ITU-T G.993.2 (2015) plus its Amendment 1.

1 Scope

This Recommendation is an enhancement to [ITU-T G.993.1] that supports transmission at a bidirectional net data rate (the sum of upstream and downstream rates) up to 200 Mbit/s on twisted pairs. This Recommendation is an access technology that exploits the existing infrastructure of copper wires that were originally deployed for POTS (plain old telephone service).

This Recommendation specifies only discrete multi-tone (DMT) modulation and incorporates components from [ITU-T G.993.1] (VDSL), [ITU-T G.992.3] (ADSL2), and [ITU-T G.992.5] (ADSL2 plus).

Whilst POTS uses approximately the lowest 4 kHz and ADSL uses approximately 2 MHz of the copper wire spectrum, this Recommendation is defined to allow the use of up to 30 MHz of the spectrum. This Recommendation can be deployed from central offices, from fibre-fed cabinets located near the customer premises, or within buildings.

The availability of bandwidth up to 30 MHz allows ITU-T G.993.2 transceivers to provide reliable high data rate operation on short loops. Without the use of the US0 band, this Recommendation should operate reliably over loop lengths that are similar to those of [ITU-T G.993.1], or slightly longer lengths due to the mandatory support of trellis coding. The addition of the US0 band and means to train echo cancellers and time-domain equalizers (TEQs) also allows this Recommendation to provide reliable operation on loops up to approximately 2 500 metres of 26 AWG (0.4 mm).

This Recommendation defines a wide range of settings for various parameters (such as bandwidth and transmitter power) that could potentially be supported by a transceiver. Therefore, this Recommendation specifies profiles to allow transceivers to support a subset of the allowed settings and still be compliant with the Recommendation. The specification of multiple profiles allows vendors to limit implementation complexity and develop implementations that target specific service requirements. Some profiles are better suited for asymmetric data rate services, whereas other profiles are better for symmetric data rate services.

The annexes of this Recommendation include band plans and power spectral density (PSD) masks that address region-specific requirements.

Like [ITU-T G.993.1], this Recommendation defines upstream power back-off (UPBO) to mitigate far-end crosstalk (FEXT) caused by upstream transmissions on shorter loops to longer loops. The mechanism is the same as in [ITU-T G.993.1].

As do other ITU-T Recommendations in the G.99x series, this Recommendation uses [ITU-T G.994.1] to initiate the transceiver training sequence.

Changes in this Recommendation relative to [ITU-T G.993.1] include:

- The definition of profiles to support a wide range of deployment scenarios (e.g., central offices, fibre-fed cabinets located near the customer premises, and within buildings).

For TPS-TC sublayer specifically, changes in this Recommendation relative to [ITU-T G.993.1] include:

- Support for STM interfaces;

- Support for PTM interfaces based on IEEE 802.3 64/65 octet encapsulation;
- Support for ToD-TC functionality for transport of time-of-day over VDSL2 links.

For PMS-TC sublayer specifically, changes in this Recommendation relative to [ITU-T G.993.1] include:

- Improved framing (based on [ITU-T G.992.3]);
- The definition of two latency paths and two bearer channels;
- Improved OLR mechanisms (based on [ITU-T G.992.3]), including optional SRA, SOS, and dynamic interleaver change;
- Control of delay variation;
- Improved overhead channel;
- Improved FEC capabilities, including a wider range of settings for the Reed-Solomon encoder and the interleaver;
- Improved interleaving with controlled memory-split between downstream and upstream;
- Support of all integer values of impulse noise protection (INP) up to 16 symbols;
- Optional impulse noise monitor function.

For PMD sublayer specifically, changes in this Recommendation relative to [ITU-T G.993.1] include:

- The definition, in annexes, of band plans up to 30 MHz to support a bidirectional net data rate up to 200 Mbit/s;
- Support for extension of the upper band edge of the US0 band to as high as 276 kHz (based on Annex M of [ITU-T G.992.3]);
- The definition of means to improve the performance of US0 (specifically, support in initialization for training of time domain equalizers and echo cancellers);
- A requirement to support the US0 band in the upstream direction for some profiles;
- Support for spectrum shaping of the US0 band in the upstream direction;
- Support for an MIB-controlled PSD mask mechanism to enable in-band spectrum shaping (based on [ITU-T G.992.5]);
- Alternative electrical length estimation method (AELE-M1);
- Optional equalized FEXT UPBO method;
- A requirement for downstream and upstream transmitters to notch, simultaneously, 16 arbitrary operator-defined RFI bands;
- Support for downstream maximum transmit power (profile dependent) of up to 20.5 dBm;
- Mandatory support of trellis coding (based on [ITU-T G.992.3]);
- The definition of receiver-determined tone ordering (based on [ITU-T G.992.3]);
- Mandatory support of all integer-bit constellations from 1 bit to 15 bits;
- Support for optional cyclic extension (CE) lengths as large as $\frac{1}{4}$ of a symbol period;
- Optional virtual noise (VN) mechanism;
- The definition of VTU-R receiver-selected pilot tone(s), including the option not to select a pilot tone;
- Insertion of a sync symbol after every 256 data symbols to signal on-line reconfiguration (OLR) transitions;
- Improvements to initialization, including the definition of a channel discovery phase, a training phase, and a channel analysis and exchange phase;
- Definition of re-initialization policy parameters;

- Definition of link activation methods and procedures;
- Support for a VTU-R lineprobe stage during initialization;
- Support for a wide range of test parameters and accuracy requirements (based on [ITU-T G.992.3]);
- The definition of a loop diagnostic mode;
- Support for an optional all-digital mode;
- Definition of downstream and full vectoring-friendly operating modes.

2 References

The following ITU-T Recommendations and other references contain provisions which, through reference in this text, constitute provisions of this Recommendation. At the time of publication, the editions indicated were valid. All Recommendations and other references are subject to revision; users of this Recommendation are therefore encouraged to investigate the possibility of applying the most recent edition of the Recommendations and other references listed below. A list of the currently valid ITU-T Recommendations is regularly published. The reference to a document within this Recommendation does not give it, as a stand-alone document, the status of a Recommendation.

- [ITU-T G.117] Recommendation ITU-T G.117 (1996), *Transmission aspects of unbalance about earth.*
- [ITU-T G.992.1] Recommendation ITU-T G.992.1 (1999), *Asymmetric digital subscriber line (ADSL) transceivers.*
- [ITU-T G.992.3] Recommendation ITU-T G.992.3 (2005), *Asymmetric digital subscriber line transceivers 2 (ADSL2).*
- [ITU-T G.992.5] Recommendation ITU-T G.992.5 (2005), *Asymmetric digital subscriber line (ADSL) transceivers – Extended bandwidth ADSL2 (ADSL2 plus).*
- [ITU-T G.993.1] Recommendation ITU-T G.993.1 (2004), *Very high speed digital subscriber line transceivers (VDSL).*
- [ITU-T G.993.5] Recommendation ITU-T G.993.5 (2010), *Self-FEXT cancellation (vectoring) for use with VDSL2 transceivers.*
- [ITU-T G.994.1] Recommendation ITU-T G.994.1 (2003), *Handshake procedures for digital subscriber line (DSL) transceivers*, plus Amendment 4 (2006).
- [ITU-T G.995.1] Recommendation ITU-T G.995.1 (2001), *Overview of digital subscriber line (DSL) Recommendations.*
- [ITU-T G.997.1] Recommendation ITU-T G.997.1 (2012), *Physical layer management for digital subscriber line transceivers.*
- [ITU-T G.998.4] Recommendation ITU-T G.998.4 (2000), *Improved impulse noise protection for DSL transceivers.*
- [ITU-T G.9954] Recommendation ITU-T G.9954 (2005), *Phoneline networking transceivers – Enhanced physical, media access, and link layer specifications.*
- [ITU-T I.361] Recommendation ITU-T I.361 (1999), *B-ISDN ATM layer specification.*
- [ITU-T I.432.1] Recommendation ITU-T I.432.1 (1999), *B-ISDN user-network interface – Physical layer specification: General characteristics.*
- [ITU-T O.9] Recommendation ITU-T O.9 (1999), *Measuring arrangements to assess the degree of unbalance about earth.*

- [ITU-T O.41] Recommendation ITU-T O.41 (1994), *Psophometer for use on telephone-type circuits*.
- [ITU-T T.35] Recommendation ITU-T T.35 (2000), *Procedure for the allocation of ITU-T defined codes for non-standard facilities*.
- [IETF RFC 5905] IETF RFC 5905 (2010), *Network Time Protocol Version 4: Protocol and Algorithms Specification*.
- [ISO 8601] ISO 8601:2000, *Data elements and interchange formats – Information interchange – Representation of dates and times*.

3 Definitions

This Recommendation defines the following terms:

- 3.1 aggregate data rate:** The net data rate plus the overhead data rate in any one direction (see Table 5-1).
- 3.2 aggregate downstream (upstream) transmit power:** The power transmitted within the entire downstream (upstream) passband.
- 3.3 anomaly:** A discrepancy between the actual and desired characteristics of an item. The desired characteristics may be expressed in the form of a specification. An anomaly may or may not affect the ability of an item to perform a required function.
- 3.4 band plan:** The partitioning of the frequency spectrum into non-overlapping frequency bands, each of which is allocated for either upstream or downstream transmission.
- 3.5 bearer channel:** A data stream at a specified data rate between two TPS-TC entities (one in each VTU) that is transported transparently over a single latency path by the PMS-TC and PMD sublayers; also referred to as "frame bearer" (see Annex L).
- 3.6 bidirectional net data rate:** The sum of upstream and downstream net data rates.
- 3.7 blackout subcarrier:** A subcarrier selected by the receiver to be allocated no power by the transmitter.
- 3.8 channel:** A connection conveying signals between two blocks (the conveyed signals represent information). Channels also convey signals between a block and the environment. Channels may be unidirectional or bidirectional.
- 3.9 channel discovery PSD:** The PSD of signals transmitted by the VTU at every frequency (i.e., in both the passband and the stopbands) during the channel discovery phase of initialization. The channel discovery PSDs for the downstream and upstream directions are denoted as CDPSD_d and CDPSD_u, respectively.
- 3.10 connection:** An association of transmission channels or circuits, switching and other functional units set up to provide a means for a transfer of user, control and management information between two or more end points (blocks) in a telecommunication network.
- 3.11 data:** All bits or bytes transported over the channel that individually convey information. Data includes both user data and overhead bits. Data does not include bits or bytes that, by themselves, do not convey any information, such as bits in a sync frame. See also "data frame" and "data symbol".
- 3.12 data frame:** A frame composed of bits from the enabled latency paths over a single symbol time period, after the addition of FEC octets and after interleaving, which is exchanged over the δ reference point between the PMS-TC and PMD sublayers.
- 3.13 data symbol:** A DMT symbol carrying a data frame.

- 3.14 data symbol rate:** The average rate at which data symbols are transmitted (see clause 10.4.4). This is not the same as "symbol rate".
- 3.15 defect:** A limited interruption in the ability of an item to perform a required function. It may or may not lead to maintenance action depending on the results of additional analysis. Successive anomalies causing a decrease in the ability of an item to perform a required function are considered a defect.
- 3.16 DMT superframe:** A set of 256 consecutive data frames followed by one sync frame, modulated onto 257 consecutive symbols.
- 3.17 DMT symbol:** The time-domain samples emerging from the DMT modulator during one symbol period, following insertion of the cyclic extension and completion of the windowing and overlap-and-add operations (see clause 10.4.4). During showtime, there are two types of DMT symbols: data symbols and sync symbols.
- 3.18 downstream:** Information flow whose direction is from a service provider (operator) to a subscriber.
- 3.19 electrical length:** An estimate of the loop attenuation, assuming that all sections of a loop obey a \sqrt{f} attenuation characteristic. Specifically, the electrical length is the attenuation, in dB at 1 MHz, of an equivalent hypothetical loop with a perfect \sqrt{f} attenuation characteristic.
- NOTE – The attenuation caused by bridged taps does not follow a \sqrt{f} characteristic, and thus the effects of bridged taps may not be accurately represented in the estimate.
- 3.20 epoch:** The origin of a timescale.
- 3.21 frame:** A general term to describe an ordered grouping of bits. See, for example, "data frame", "sync frame", and "overhead frame".
- 3.22 frame bearer:** See the definition for "bearer channel".
- 3.23 HDLC frame:** A group of data bytes encapsulated into the HDLC structure (see clause 8.2.3).
- 3.24 indicator bits:** Bits used for operations and maintenance (OAM) purposes; embedded in the overhead octets.
- 3.25 interface:** A point of demarcation between two blocks, through which information flows from one block to the other. An interface may be a physical interface or a logical interface.
- 3.26 layer/sublayer:** A collection of objects of the same hierarchical rank.
- 3.27 limit PSD mask:** A PSD mask specified in an annex of this Recommendation. The limit PSD mask is defined at all frequencies (i.e., in both the passband and the stopbands). The limit PSD masks for the downstream and upstream directions are denoted LIMITMASK_ds and LIMITMASK_us, respectively.
- 3.28 line rate:** The data rate transmitted at the U-x reference point in any one direction. This is the total data rate plus trellis coding overhead.
- 3.29 logical (functional) interface:** An interface where the semantic, syntactic, and symbolic attributes of information flows are defined. Logical interfaces do not define the physical properties of signals used to represent the information. A logical interface can be an internal or external interface. It is defined by a set of information flows and associated protocol stacks.
- 3.30 loop timing:** A mode of operation where the VTU-R clock is extracted from the received signal. In loop timing mode, the VTU-R operates as a slave; the VTU-R transmit and receive clocks are equal to the transmit clock of the VTU-O, within the tolerance introduced by the implementation.

- 3.31 MEDLEY reference PSD:** The PSD of signals transmitted by a VTU at every frequency (i.e., in both the passband and the stopbands) during the training phase and the channel analysis and exchange phase of initialization. The MEDLEY reference PSDs in the downstream and upstream directions are denoted as MREFPSDds and MREFPSDus, respectively.
- 3.32 MEDLEY reference PSD mask:** The MEDLEY reference PSD mask is the transmit PSD mask limited at every frequency (i.e., in both the passband and the stopbands) by the PSD ceiling and limited to -80 dBm/Hz at frequencies corresponding to the designated RFI bands. In the upstream direction, the MEDLEY reference PSD mask is further reduced in accordance with the UPBO requirements. The MEDLEY reference PSD masks in the downstream and upstream directions are denoted as MREFMASKds and MREFMASKus, respectively.
- 3.33 MEDLEY set:** A subset of the SUPPORTEDCARRIERS set. It is determined during the channel discovery phase and contains the subcarriers that will be used for transmission of initialization signals after the channel discovery phase. For each subcarrier in the MEDLEY set, a b_i and a g_i value will be exchanged during the channel analysis and exchange phase. Blackout subcarriers are not part of the MEDLEY set. The MEDLEY set is denoted MEDLEYds and MEDLEYus, respectively, for the downstream and upstream directions.
- 3.34 message overhead data rate of latency path p :** The part of the overhead data rate assigned for the message transport for latency path p in any one direction of transmission (see Table 5-1).
- 3.35 MIB PSD mask:** A PSD mask specified by the operator to restrict the transmit PSD in the passband to levels below those allowed by the applicable limit PSD mask. The MIB PSD mask is defined only within the passband and lies at or below the limit PSD mask. Operators may choose not to specify a MIB PSD mask for one or both transmission directions or in specific bands of the passband. The MIB PSD masks for the downstream and upstream directions are denoted as MIBMASKds and MIBMASKus, respectively. The MIB PSD mask does not incorporate PSD requirements for RFI bands, which are specified separately (see definition of "RFI bands").
- 3.36 monitored subcarrier:** A subcarrier (but not a pilot tone) in the MEDLEY set that has $b_i = 0$ and $g_i > 0$.
- 3.37 mux data frame:** The grouping of octets from different bearer channels within the same latency path, after the overhead data octets have been added.
- 3.38 net data rate of bearer channel n :** The data rate of a single bearer channel n at the α/β interface of the user plane in any one direction of transmission (see Table 5-1).
- 3.39 net data rate of latency path p :** The sum of net data rates over all bearer channels of latency path p (see Table 5-1).
- 3.40 net data rate:** The sum of net data rates over all latency paths (see Table 5-1).
- 3.41 network:** A collection of interconnected elements that provide connection services to users.
- 3.42 network timing reference:** An 8 kHz timing marker used to support the distribution of a timing reference over the network.
- 3.43 overhead data rate of latency path p :** The data rate of the overhead channel assigned for latency path p in any one direction of transmission (see Table 5-1).
- 3.44 overhead data rate:** The sum of overhead data rates over all latency paths (see Table 5-1).
- 3.45 overhead (OH) frame:** A frame composed of a CRC byte, followed by a Syncbyte, followed by other bytes from the overhead channel (see Table 9-4).
- 3.46 overhead (OH) subframe:** A subdivision of an OH frame (see Figure 9-4).

- 3.47 overhead (OH) superframe:** A specific number of consecutive overhead frames in which the first overhead frame carries a Syncbyte of value AC_{16} . The overhead superframe is not related to the DMT superframe.
- 3.48 passband:** The portion of the frequency spectrum that is allowed to be used for transmission in one direction. The passband may consist of multiple, disjointed portions of the frequency spectrum. The upstream and downstream passbands depend on the selected band plan and profile.
- 3.49 precision time protocol (PTP):** The protocol defined by IEEE 1588-2008.
- 3.50 primitives:** Basic measures of performance, usually obtained from digital signal line codes and frame formats, or as reported in overhead indicators from the far end. Performance primitives are categorized as events, anomalies and defects. Primitives may also be basic measures of other quantities (e.g., a.c. or battery power), usually obtained from equipment indicators.
- 3.51 PSD ceiling:** The PSD level, independent of frequency (and indicated by a single value), that limits the transmit PSD mask when the MEDLEY reference PSD mask is determined. The PSD ceilings in the downstream and upstream directions are denoted as MAXMASKds and MAXMASKus, respectively. The PSD ceiling determines the transmit power cut-back and is set at the end of the channel discovery phase of initialization. Initial PSD ceilings in the downstream and upstream directions, used during the channel discovery phase of initialization, are denoted as CDMAXMASKds and CDMAXMASKus, respectively (see clause 12.3.3).
- 3.52 reference point:** A set of interfaces between any two related blocks through which information flows from one block to the other. A reference point comprises one or more logical (non-physical) information-transfer interfaces, and one or more physical signal-transfer interfaces.
- 3.53 RFI bands:** One or more operator-specified frequency bands in which the PSD transmitted by a VTU is to be no higher than -80 dBm/Hz. A single set of RFI bands (RFIBANDS) is specified, which applies to both downstream and upstream transmission.
- 3.54 showtime:** The state of either the VTU-O or VTU-R that is reached after the initialization procedure has been completed in which bearer channel data are transmitted.
- 3.55 splitter:** A filter that separates VDSL2 signals from the voiceband or ISDN signals (frequently called a POTS or ISDN splitter, even though the voiceband signals may comprise more than POTS).
- 3.56 subcarrier:** A fundamental element of a discrete multi-tone (DMT) modulator. The modulator partitions the channel bandwidth into a set of parallel subchannels. The centre frequency of each subchannel is a subcarrier, onto which bits may be modulated for transmission over a channel (see clause 10).
- 3.57 subcarrier group:** A grouping of G (where $G = 1, 2, 4,$ or 8) adjacent subcarriers. Subcarrier groups are used to reduce the number of test parameter data points that need to be stored by and communicated between the VTU-O and VTU-R. Each subcarrier in a subcarrier group is characterized by the same value of a test parameter (see clause 11.4.1).
- 3.58 SUPPORTEDCARRIERS set:** The set of subcarriers allocated for transmission in one direction, as determined by the band plan and any restrictions imposed by the operator via the CO-MIB (e.g., VDSL2-CARMASK as defined in [ITU-T G.997.1]); denoted SUPPORTEDCARRIERSds and SUPPORTEDCARRIERSus, respectively, for the downstream and upstream directions.
- 3.59 symbol:** See DMT symbol.
- 3.60 symbol rate:** The rate at which DMT symbols are transmitted from the VTU-O to the VTU-R and vice versa. This is not the same as "data symbol rate".

- 3.61 sync frame:** A frame composed of all ZEROS or all ONES that is modulated onto a sync symbol as defined in clause 10.5.1.
- 3.62 sync symbol:** A DMT symbol carrying a sync frame.
- 3.63 Syncbyte:** The second octet of each overhead frame, which indicates whether the OH frame is the first in an OH superframe.
- 3.64 Syncflag:** A sync symbol in which the sync frame bits are inverted relative to the sync frame modulated by the most recently transmitted sync symbol (i.e., if the previous sync frame was all ZEROS, the Syncflag would correspond to a sync frame of all ONES, and vice versa). The Syncflag is used to signal online reconfiguration transitions.
- 3.65 system:** A collection of interacting objects that serves a useful purpose; typically, a primary subdivision of an object of any size or composition (including domains).
- 3.66 ToD phase difference value:** The value of the VTU-x Real-time Clock modulo 125 μ s at the moment the reference sample crosses the U-x reference point (i.e., phase of t_n event relative to the time-of-day, in nanoseconds, see also clause 8.4.3.2).
- 3.67 total data rate:** The aggregate data rate plus the Reed-Solomon FEC overhead rate in any one direction (see Table 5-1).
- 3.68 transmit power back-off (PBO):** Reduction of the transmitted PSD for spectral compatibility purposes, via PSD shaping using a predefined method that is dependent only on loop conditions and is independent of the service (bearer) requirements such as net data rates, INP, and delay.
- 3.69 transmit power cut-back (PCB):** Reduction of the transmitted PSD using the PSD ceiling mechanism. The PCB is dependent on the service (bearer) requirements, such as net data rates, INP, and delay, and on the desired SNR margin. The PCB also accommodates the dynamic range of the far-end receiver.
- 3.70 transmit PSD mask:** The PSD mask derived as the minimum at every frequency (i.e., in both the passband and the stopbands) of 1) the relevant Limit PSD mask; 2) the MIB PSD mask, if defined; and 3) the vendor-discretionary PSD mask restrictions imposed by the VTU-O for the downstream and upstream directions. The transmit PSD masks for the downstream and upstream directions are denoted as PSDMASKds and PSDMASKus, respectively.
- 3.71 upstream:** Information flow whose direction is from a subscriber to a service provider (operator).
- 3.72 user:** A service-consuming object or system (block).
- 3.73 voiceband:** 0 to 4 kHz; expanded from the traditional 0.3 to 3.4 kHz to deal with voiceband data services wider than POTS.

4 Abbreviations and acronyms

This Recommendation uses the following abbreviations and acronyms:

AGC	Automatic Gain Control
AN	Access Node
ATM	Asynchronous Transfer Mode
ATM-TC	Asynchronous Transfer Mode – Transmission Convergence
BER	Bit Error Ratio
CE	Cyclic Extension

CPE	Customer Premises Equipment
CRC	Cyclic Redundancy Check
DMT	Discrete Multi-Tone
DS	Downstream
DSL	Digital Subscriber Line
EC	Echo Canceller (or Cancellation)
EIA	External OAM Interface Adapter
eoc	embedded operations channel
FCS	Frame Check Sequence
FDD	Frequency Division Duplexing
FEC	Forward Error Correction
flcd-n	far-end loss of cell delineation defect
flpr	far-end loss of power primitive
GSTN	General Switched Telephone Network
HDLC	High-level Data Link Control
HPF	High-Pass Filter
IB	Indicator Bit
IDFT	Inverse Discrete Fourier Transform
INP	Impulse Noise Protection
ISDN	Integrated Services Digital Network
lcd-n	loss of cell delineation defect
LCL	Longitudinal Conversion Loss
LOF	Loss Of Frame
lom	loss of margin defect
lom-fe	far-end loss of margin defect
LOS	Loss Of Signal
los	loss of signal defect
los-fe	far-end loss of signal defect
LPF	Low-Pass Filter
lpr	loss of power primitive
LSB	Least Significant Bit
LTR	Local Timing Reference
MBDC	Minimum Bidirectional net Data rate Capability
MDF	Mux Data Frame
MIB	Management Information Base
MPS-TC	Management Protocol Specific Transmission Convergence
MSB	Most Significant Bit

mux	Multiplex
NMS	Network Management System
<i>NSC_{us}</i>	Number of Subcarriers in MEDLEY _{us} set
<i>NSC_{ds}</i>	Number of Subcarriers in MEDLEY _{ds} set
NSF	Non-Standard Facility
NT	Network Termination
NTR	Network Timing Reference
OAM	Operations, Administration and Maintenance
OH	Overhead
OLR	On-Line Reconfiguration
ONU	Optical Network Unit
PMD	Physical Media Dependent
PMS	Physical Media Specific
PMS-TC	Physical Media Specific Transmission Convergence
POTS	Plain Old Telephone Service; one of the services using the voiceband; sometimes used as a descriptor for all voiceband services
PRBS	Pseudo-Random Binary Sequence
PSD	Power Spectral Density
PTM	Packet Transfer Mode
PTM-TC	Packet Transfer Mode Transmission Convergence
QAM	Quadrature Amplitude Modulation
rdi	remote defect indication defect
RFI	Radio Frequency Interference
rms	root mean square
ROC	Robust Overhead Channel
RS	Reed-Solomon
RTC	Real-Time Clock
RX (Rx)	Receiver
SAVN	Showtime Adaptive Virtual Noise
SC	Segment Code
sef	severely errored frame defect
SNR	Signal-to-Noise Ratio
SOC	Special Operations Channel
SOS	Save Our Showtime
STM	Synchronous Transfer Mode
STM-TC	Synchronous Transfer Mode – Transmission Convergence
TA	Timing Advance

TC	Transmission Convergence
TCM-ISDN	Time Compression Multiplexed – Integrated Services Digital Network
TEQ	Time-domain Equalizer
ToD	Time-of-Day
TPS	Transport Protocol Specific
TPS-TC	Transport Protocol Specific – Transmission Convergence
TX (Tx)	Transmitter
UPBO	Upstream Power Back-Off
US	Upstream
VDSL	Very High Speed Digital Subscriber Line
VME	VDSL2 Management Entity
VN	Virtual Noise
VTU	VDSL2 Transceiver Unit
VTU-O	VTU at the Optical Network Unit (or central office, exchange, cabinet, etc., i.e., operator end of the loop)
VTU-R	VTU at the Remote site (i.e., subscriber end of the loop)

5 Reference models

The functional, application, and protocol reference models of VDSL2 devices specified in this clause fit within the family of DSL Recommendations described in [ITU-T G.995.1]. Additionally, VDSL2 devices rely on constituent components described within [ITU-T G.997.1].

5.1 VTU functional model

The functional model of VDSL2, which includes functional blocks and interfaces of the VTU-O and VTU-R referenced in this Recommendation, is presented in Figure 5-1. The model illustrates the most basic functionality of VDSL2 and contains both an application-invariant section and an application-specific section. The application-invariant section consists of the physical medium dependent (PMD) sublayer and physical media specific part of the transmission convergence sublayer (PMS-TC), which are defined in clauses 10 and 9, respectively. The application-specific parts related to the user plane are defined in clause 8.1 and Annex L and are confined to the transport protocol specific transmission convergence (TPS-TC) sublayer and application interfaces. The management protocol specific TC (MPS-TC) is intended for management data transport and is described in clause 8.2. The VDSL2 management entity (VME) supports management data communication protocols and is described in clause 11.2. Management plane functions at higher layers are typically controlled by the operator's network management system (NMS) and are not shown in Figure 5-1. The NTR-TC supports transport of the 8 kHz network timing reference (NTR) to the VTU-R and is described in clause 8.3. The ToD-TC supports distribution of accurate time-of-day to the VTU-R and is described in clause 8.4.

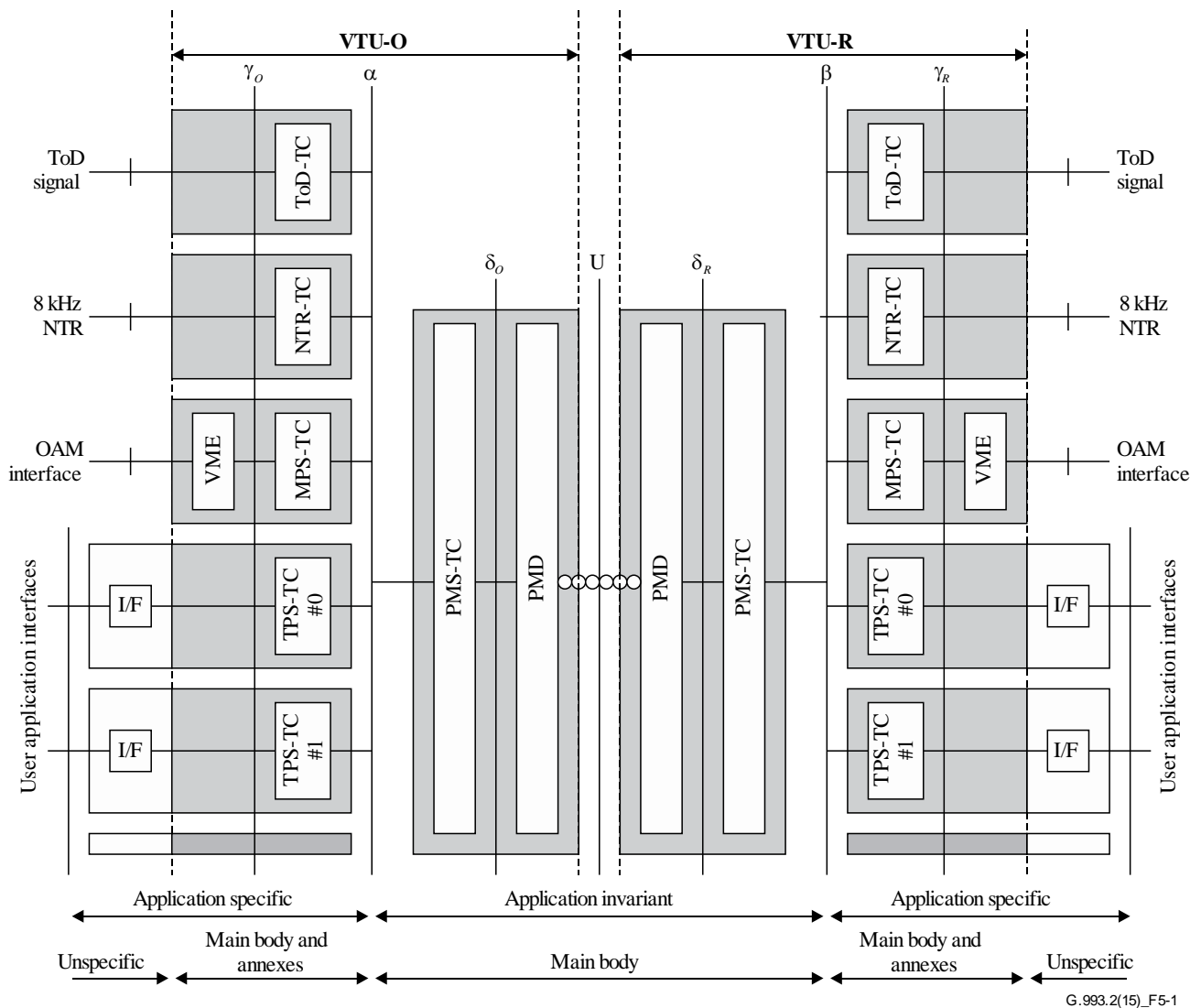

Figure 5-1 – VDSL2 and VTU functional model

The principal functions of the PMD are symbol timing generation and recovery, encoding and decoding, and modulation and demodulation. The PMD may also include echo cancellation and line equalization.

The PMS-TC sublayer contains framing and frame synchronization functions, as well as forward error correction (FEC), error detection, interleaving and de-interleaving, scrambling and descrambling functions. Additionally, the PMS-TC sublayer provides an overhead channel that is used to transport management data (control messages generated by the VME).

The PMS-TC is connected to the PMD across the δ interface, and is connected to the TPS-TC across α and β interfaces in the VTU-O and the VTU-R, respectively.

The TPS-TC is application specific and is mainly intended to convert applicable data transport protocols into the unified format required at the α and β interfaces and to provide bit rate adaptation between the user data and the data link established by the VTU. Depending on the specific application, the TPS-TC sublayer may support one or more channels of user data. The TPS-TC communicates with the user data interface blocks at the VTU-R and VTU-O across the γ_R and γ_O interfaces, respectively. The definition of the data interface blocks is beyond the scope of this Recommendation.

The MPS-TC, NTR-TC, and ToD-TC provide TPS-TC functions for management data, 8 kHz NTR signals, and ToD signal respectively.

The VME function facilitates the management of the VTU. It communicates with higher management layer functions in the management plane as described in [ITU-T G.997.1], e.g., the NMS controlling the CO-MIB. Management information is exchanged between the VME functions of the VTU-O and VTU-R through the overhead channel provided by the PMS-TC. The MPS-TC converts the incoming management data into the unified format required at the α and β interfaces to be multiplexed into the PMS-TC. The management information contains indications of anomalies and defects, and related performance monitoring counters, and management command/response messages facilitating procedures defined for use by higher layer functions, specifically for testing purposes.

The α , β , γ_R and γ_O interfaces are only intended as logical separations and are defined as a set of functional primitives; they are not expected to be physically accessible. Concerning the user data plane, the γ_R and γ_O interfaces are logically equivalent, respectively, to the T and V interfaces shown in Figure 5-4.

5.2 User plane protocol reference model

The user plane protocol reference model is shown in Figure 5-2 and corresponds to the VDSL2 functional model shown in Figure 5-1. The user plane protocol reference model is included to emphasize the layered nature of this Recommendation and to provide a view that is consistent with the generic xDSL protocol reference model shown in [ITU-T G.995.1].

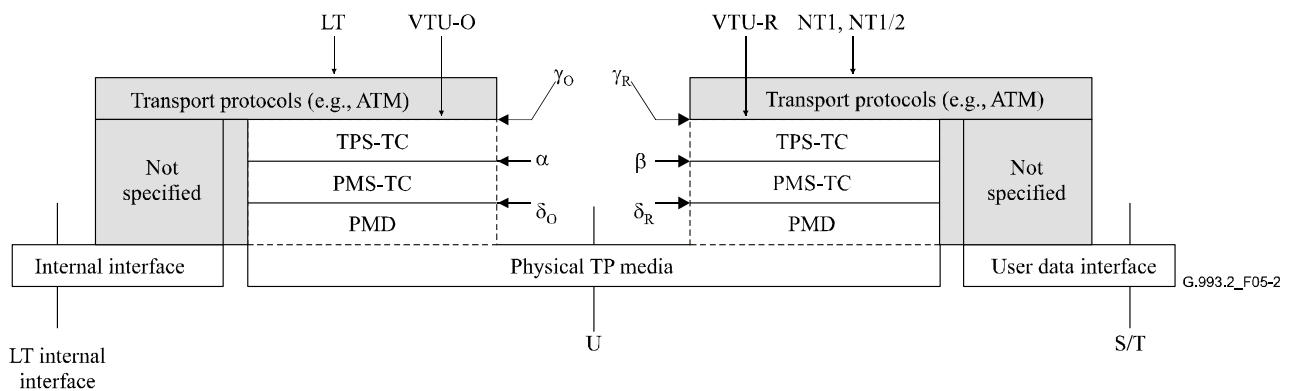

Figure 5-2 – User plane protocol reference model

Table 5-1 summarizes the data rate terminology and definitions applicable at various reference points. The reference points refer to those shown in the reference model in Figure 5-2 and the PMS-TC functional model in Figure 9-1.

Table 5-1 – Data rate terminology and definitions

Data rate	Notation/equation	Refer to	Reference point
Net data rate for bearer channel n (of latency path p)	NDR_{pn}	Table 9-8	α , β (user plane)
Net data rate for latency path p	$NDR_p = \sum_n NDR_{pn}$	Table 9-8	α , β (user plane)
Net data rate	$\sum_p NDR_p$	–	α , β (user plane)
Overhead data rate for latency path p	OR_p	Table 9-8	α , β (management plane)

Table 5-1 – Data rate terminology and definitions

Data rate	Notation/equation	Refer to	Reference point
Overhead data rate	$\sum_p OR_p$	Table 9-8	α, β (management plane)
Message overhead data rate for latency path p	msg_p	Table 9-8	α, β (management plane)
Aggregate data rate for latency path p = net data rate for latency path p + overhead data rate for latency path p	$NDR_p + OR_p$	Table 9-8, clause 9.1	A
Aggregate data rate = net data rate + overhead data rate	$\sum_p NDR_p + OR_p$	Table 9-8, clause 9.1	A
Total data rate for latency path p = aggregate data rate for latency path p + RS coding overhead for latency path p	$TDR_p = L_p \times f_s$	Table 9-8, clause 9.1	C
Total data rate = aggregate data rate + RS coding overhead	$TDR = \left(\sum_p L_p \right) \times f_s$	Table 9-8, clause 9.1	δ
Line rate = total data rate + trellis coding overhead rate	$\left(\sum_i b_i \right) \times f_s$	Clauses 10.3.3 and 10.4.4	U
Bidirectional net data rate (related to MBDC)	$\sum_p NDR_{DS_p} + \sum_p NDR_{US_p}$	Table 9-8	α, β (user plane)

5.3 Management plane reference model

The management plane protocol reference model is shown in Figure 5-3 and corresponds to the VDSL2 functional model shown in Figure 5-1. The management plane protocol reference model relates specifically to the transport of management data through the VDSL2 link.

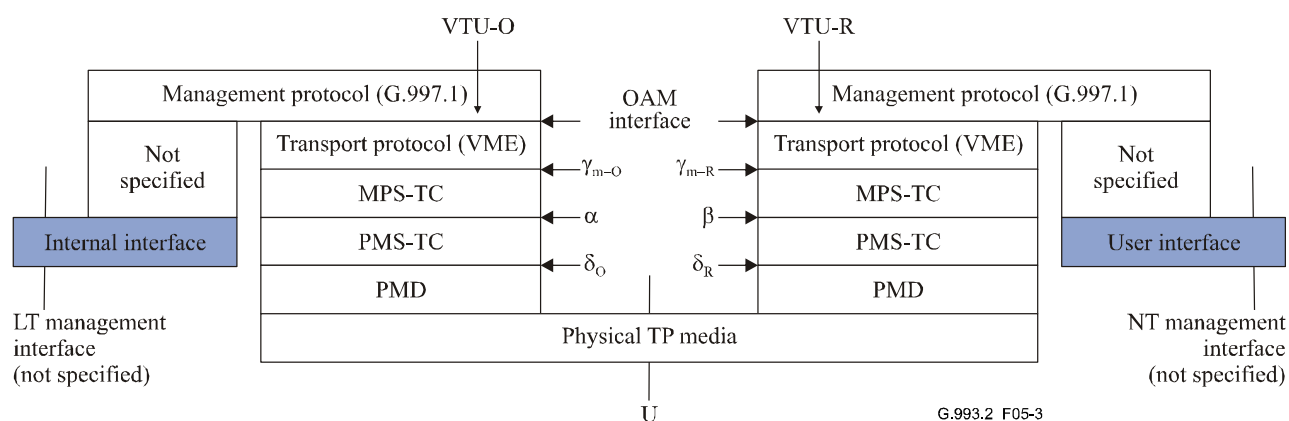

Figure 5-3 – Management plane protocol reference model

5.4 Application reference models

The application models for VDSL2 are based on the generic reference configuration described in clause 6.1 of [ITU-T G.995.1]. There are three separate application models:

- Data service only;
- Data service with underlying POTS service; and
- Data service with underlying ISDN service.

The application reference model for remote deployment with POTS or ISDN service facilitated by a splitter is shown in Figure 5-4. The application model for splitterless remote deployment is shown in Figure 5-5. An optional low-pass filter may be included to provide additional isolation between the VTU-R and narrow-band network CPE such as telephone sets, voiceband modems, or ISDN terminals.

The location of the filters (HPF and LPF) in application models presented in Figures 5-4 and 5-5 is functional only; the physical location and specific characteristics of splitters and the filter may be regionally specific. The filters at the CPE side shown in Figure 5-4 may be implemented in a variety of ways, including splitters, and in-line filters, and filters integrated with VTU devices, and filters integrated with narrow-band network CPE.

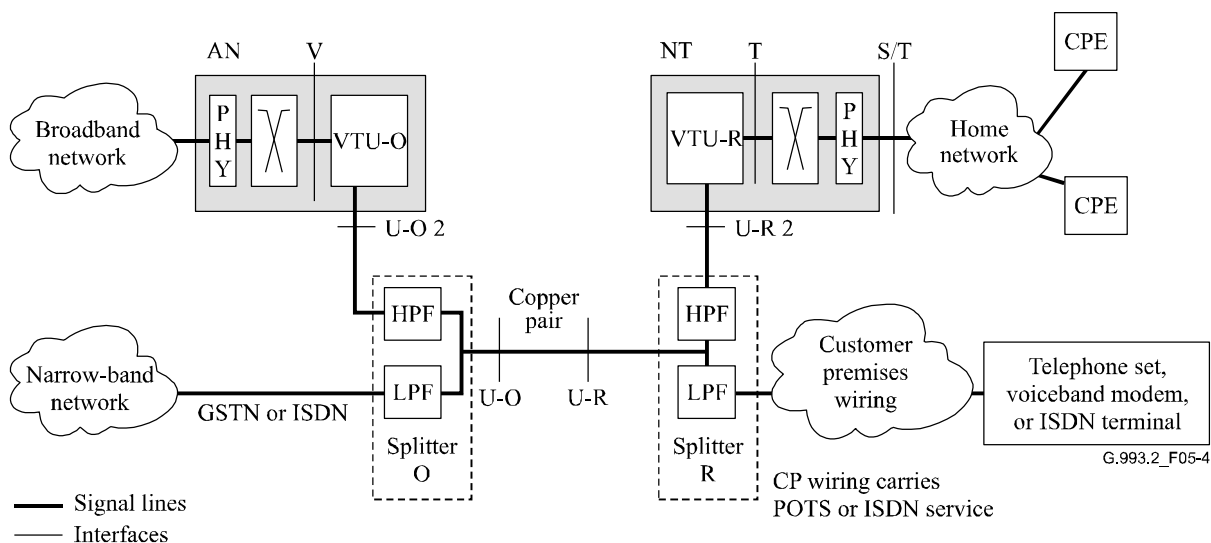

Figure 5-4 – Generic application reference model for remote deployment with splitter

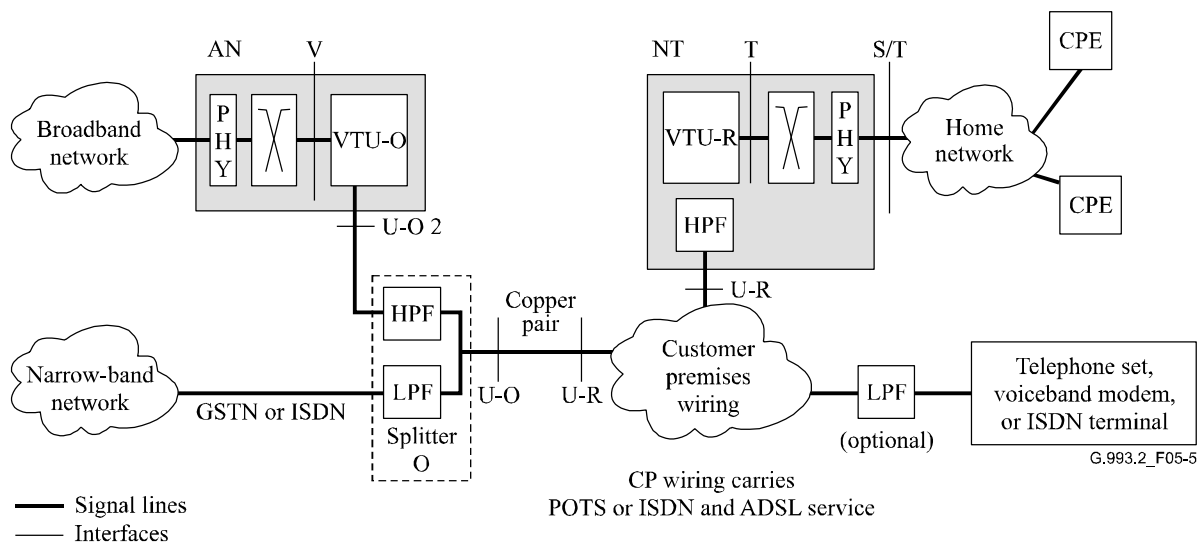

Figure 5-5 – Generic application reference model for splitterless remote deployment

NOTE 1 – The U-O and U-R interfaces are fully defined in this Recommendation. The V and T interfaces are defined only in terms of logical functions, not physical implementations. The S/T interface is not defined in this Recommendation.

NOTE 2 – Implementation of the V and T interfaces is optional when interfacing elements are integrated into a common element.

NOTE 3 – One or both of the high-pass filters, which are part of the splitters, may be integrated into the VTU. If so, the U-O2 and U-R2 interfaces become the same as the U-O and U-R interfaces, respectively.

NOTE 4 – More than one type of T interface may be defined, and more than one type of S/T interface may be provided from a VDSL2 NT (e.g., NT1 or NT2 types of functionalities).

NOTE 5 – Specifications for service splitters (Splitter O) are found in clause 14.2. Further specifications may also be found in regional annexes (see for example Annex C.3).

NOTE 6 – The low-pass filter shown at the customer premises in Figure 5-5 is also known as an in-line filter. In-line filter characteristics are outside the scope of this Recommendation, and are typically specified by regional standards bodies.

NOTE 7 – VDSL2 operating in the splitterless remote deployment mode is highly likely to suffer severe service impairments due to the topology and uncertain quality of the in-premises wiring. Star topology wiring practices, in particular, will lead to deep notches in the frequency response of the transmission path due to multiple signal reflections. In addition, poor balance, routing close to sources of electrical noise, and exposure to strong radio signals can all lead to high levels of RFI.

NOTE 8 – The access node (AN) consists of the VTU-O, the cross-connect (which includes switching and interworking functions for connection to the broadband network), and the physical interface to the broadband network (labelled PHY in Figures 5-4 and 5-5). The network terminal (NT) consists of the VTU-R, the cross-connect (which includes the switching and interworking functions for connection to the home network), and the physical interfaces to the home network (labelled PHY in Figures 5-4 and 5-5). This Recommendation only addresses the definition of the VTU-O and VTU-R.

5.4.1 Data service

To provide data-only service, VDSL2 may be operated in all-digital mode, without leaving any bandwidth for an underlying service. A data-only service may also be provided by a VDSL2 system that leaves bandwidth for underlying POTS or ISDN service, even if there is no underlying service.

Figure 5-6 illustrates the typical application model for delivering data service over VDSL2. The VTU-R is part of the VDSL2 NT, which is typically connected to one or more user terminals, and which may include data terminals, telecommunications equipment, or other devices; these connections are designated by S/T reference points. The connection between the VTU-R and VTU-O is through a copper pair, with the customer premises endpoint designated as the U-R reference point

and the network endpoint designated as the U-O reference point. The VTU-O is a part of the access node (AN), which is typically connected to a broadband access network at the V reference point. In this application model there is no underlying narrow-band service carried on the same copper pair as VDSL2.

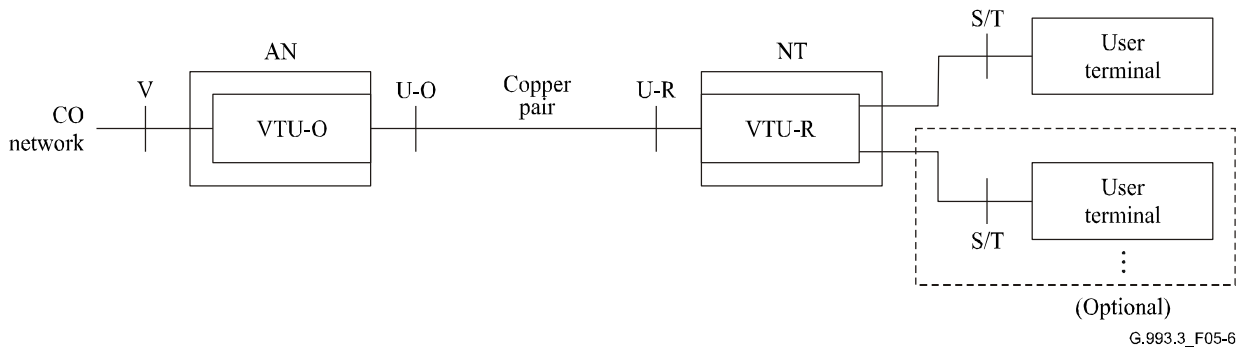

Figure 5-6 – Data service application model

5.4.2 Data with POTS service

The typical application model for delivering data service over VDSL2 with an underlying POTS service on the same copper pair is illustrated in Figure 5-7 (remote deployment with splitter). The VTU-R is part of the VDSL2 NT that typically connects to one or more user terminals, which may include data terminals, telecommunications equipment, or other devices. These connections are designated by S/T reference points. The VTU-R is separated from the narrow-band devices by a combination of a high-pass filter (HPF) and a low-pass filter (LPF). One or more narrow-band devices (POTS telephones, telephone answering devices, voiceband analogue modems, or other devices) are also part of the application model at the customer premises. In remote deployments with a splitter, the narrow-band devices are connected to the U-R reference point through a common low-pass filter element.

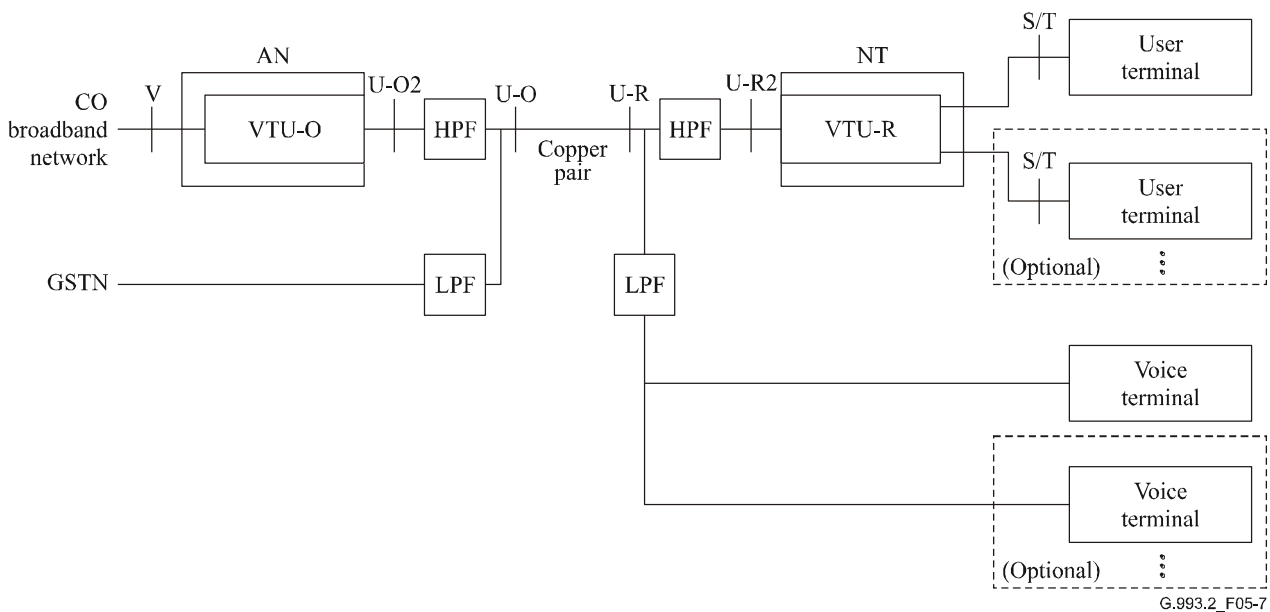

Figure 5-7 – Data with POTS service application model for remote deployment with splitter

Figure 5-8 shows a splitterless remote deployment. In splitterless remote deployments, the narrow-band devices may be connected to the U-R reference point either directly, or through a low-pass filter (LPF) per device.

The VTU-O is a part of the AN, which is typically connected to a broadband access network at the V reference point. The VTU-O is connected to the U-O reference point through a high-pass filter (HPF); a low-pass filter (LPF) attached at the U-O reference point isolates the VTU-O from the GSTN network.

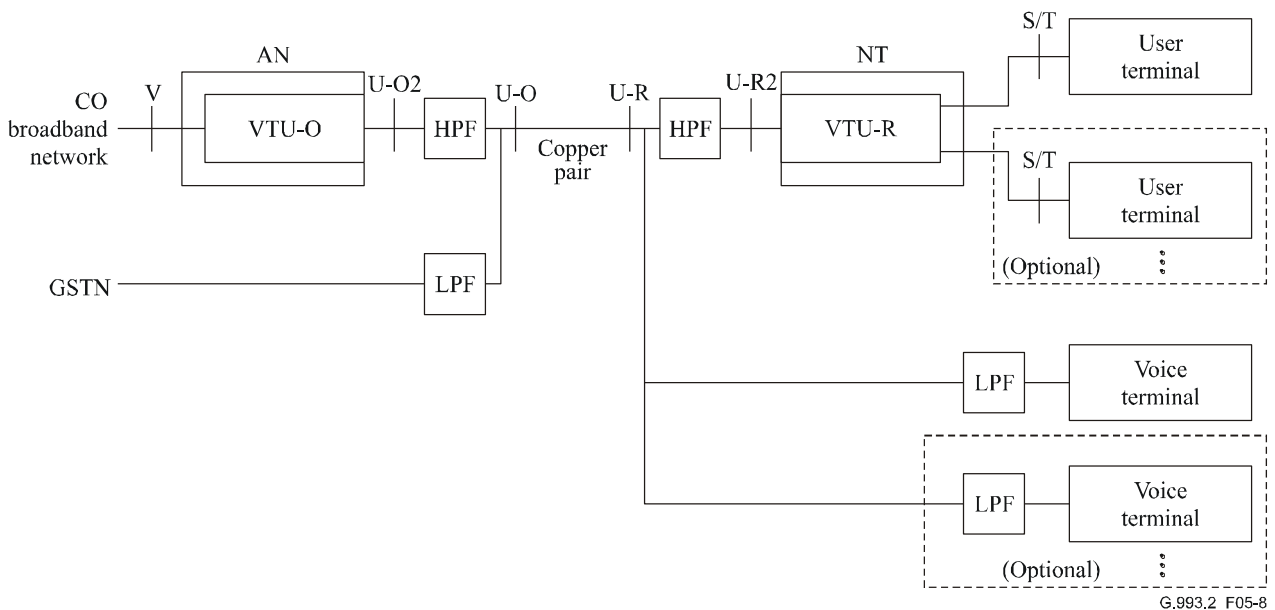

Figure 5-8 – Data with POTS service application model for splitterless remote deployment

NOTE 1 – The low-pass filters shown at the customer premises in Figure 5-8 are also known as in-line filters. In-line filter characteristics are outside the scope of this Recommendation, and are typically specified by regional standards bodies.

NOTE 2 – VDSL2 operating in the splitterless remote deployment mode is highly likely to suffer severe service impairments due to the topology and uncertain quality of the in-premises wiring. Star topology wiring practices, in particular, will lead to deep notches in the frequency response of the transmission path due to multiple signal reflections. In addition, poor balance, routing close to sources of electrical noise, and exposure to strong radio signals can all lead to high levels of RFI.

5.4.3 Data with ISDN service

Figure 5-9 illustrates the typical application model for delivering data service over VDSL2 with an underlying ISDN service on the same copper pair. The VTU-R is part of the VDSL2 NT that typically connects to one or more user terminals, which may include data terminals, telecommunications equipment, or other devices; these connections are designated by S/T reference points. The VTU-R is separated from the copper pair by a high-pass filter (HPF). The ISDN NT at the customer premises is separated from the copper pair by a low-pass filter (LPF). One or more voiceband or ISDN terminals (e.g., POTS or ISDN telephones, telephone answering devices, voiceband analogue modems, or other devices) are connected to the ISDN NT.

The VTU-O is a part of the AN, which is typically connected to a broadband access network at the V reference point. The VTU-O is connected to the U-O reference point through a high-pass filter (HPF); a low-pass filter (LPF) attached at the U-O reference point isolates the VTU-O from the ISDN network.

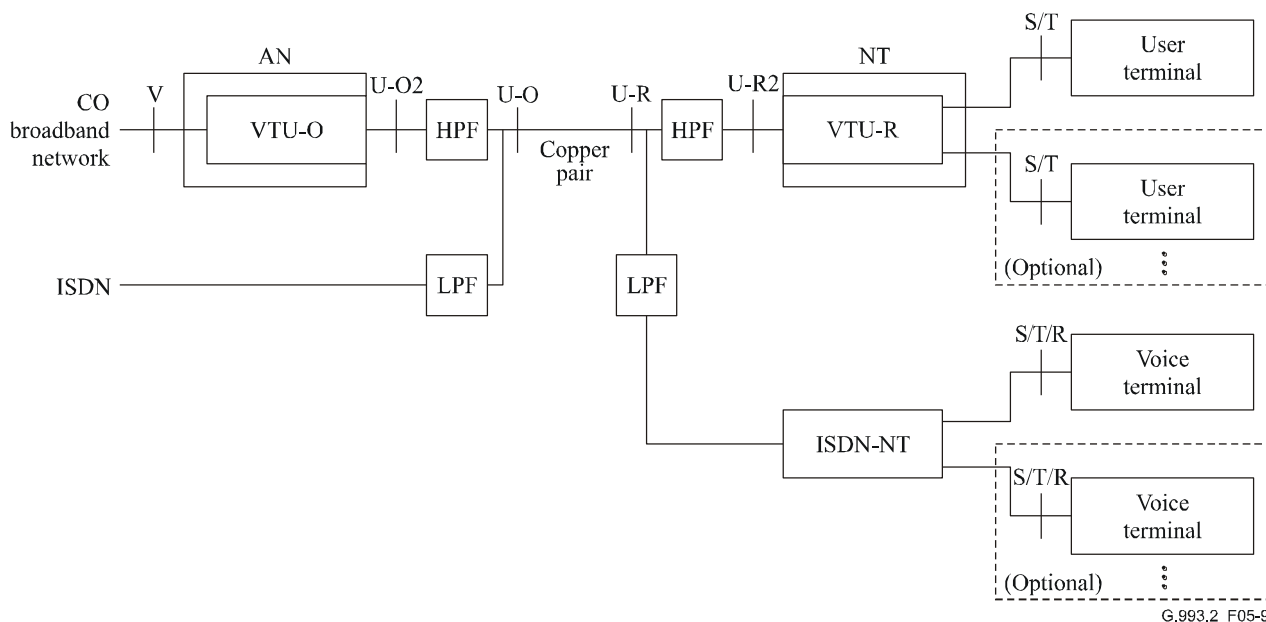

Figure 5-9 – Data with ISDN service application model

6 Profiles

6.1 Definition

This Recommendation defines a wide range of settings for various parameters that could potentially be supported by a VDSL2 transceiver. Profiles are specified to allow transceivers to support a subset of the allowed settings and still be compliant with this Recommendation. The specification of multiple profiles allows vendors to limit implementation complexity and develop implementations that target specific service requirements.

VDSL2 transceivers compliant with this Recommendation shall comply with at least one profile specified in this Recommendation. Compliance with more than one profile is allowed. In addition to complying with at least one profile, VDSL2 transceivers shall comply with at least one annex specifying spectral characteristics (see Annexes A, B and C).

The eight VDSL2 profiles (8a, 8b, 8c, 8d, 12a, 12b, 17a, and 30a) are defined in Table 6-1.

NOTE – Some parameter values are dependent on the applicable frequency plan. Explicit definitions of the parameters are provided in clauses 3 and 6.2.

Table 6-1 – VDSL2 profiles

Frequency plan	Parameter	Parameter value for profile							
		8a	8b	8c	8d	12a	12b	17a	30a
All	Maximum aggregate downstream transmit power (dBm)	+17.5	+20.5	+11.5	+14.5	+14.5	+14.5	+14.5	+14.5
All	Minimum aggregate downstream transmit power (dBm)	For further study	For further study	For further study	For further study	For further study	For further study	For further study	For further study

Table 6-1 – VDSL2 profiles

Frequency plan	Parameter	Parameter value for profile							
		8a	8b	8c	8d	12a	12b	17a	30a
All	Maximum aggregate upstream transmit power (dBm)	+14.5	+14.5	+14.5	+14.5	+14.5	+14.5	+14.5	+14.5
All	Minimum aggregate upstream transmit power (dBm)	For further study	For further study	For further study	For further study	For further study	For further study	For further study	For further study
All	Subcarrier spacing (kHz)	4.3125	4.3125	4.3125	4.3125	4.3125	4.3125	4.3125	8.625
All	Support of upstream band zero (US0)	Required	Required	Required	Required	Required	Regional annex dependent	Regional annex dependent	Not Supported
All	Minimum bidirectional net data rate capability (MBDC)	50 Mbit/s	50 Mbit/s	50 Mbit/s	50 Mbit/s	68 Mbit/s	68 Mbit/s	100 Mbit/s	200 Mbit/s
All	Aggregate interleaver and de-interleaver delay (octets)	65 536	65 536	65 536	65 536	65 536	65 536	98 304	131 072
All	Maximum interleaving depth (D_{max})	2 048	2 048	2 048	2 048	2 048	2 048	3 072	4 096
All	Parameter $(1/S)_{max}$ downstream	24	24	24	24	24	24	48	28
All	Parameter $(1/S)_{max}$ upstream	12	12	12	12	24	24	24	28
Annex A (998)	Index of highest supported downstream data-bearing subcarrier (upper band edge frequency in MHz (informative))	1 971 (8.5)	1 971 (8.5)	1 971 (8.5)	1 971 (8.5)	1 971 (8.5)	1 971 (8.5)	4 095 (17.660)	2 666 (23)
	Index of highest supported upstream data-bearing subcarrier (upper band edge frequency in MHz (informative))	1 205 (5.2)	1 205 (5.2)	1 205 (5.2)	1 205 (5.2)	2 782 (12)	2 782 (12)	2 782 (12)	3 478 (30)

Table 6-1 – VDSL2 profiles

Frequency plan	Parameter	Parameter value for profile							
		8a	8b	8c	8d	12a	12b	17a	30a
Annex B (998E)	Index of highest supported downstream data-bearing subcarrier (upper band edge frequency in MHz (informative))	1 971 (8.5)	1 971 (8.5)	1 971 (8.5)	1 971 (8.5)	1 971 (8.5)	1 971 (8.5)	4 095 (17.660)	3 478 (30)
	Index of highest supported upstream data-bearing subcarrier (upper band edge frequency in MHz (informative))	1 205 (5.2)	1 205 (5.2)	1 205 (5.2)	1 205 (5.2)	2 782 (12)	2 782 (12)	3 246 (14)	2 885 (24.890)
Annex B (998 ADE)	Index of highest supported downstream data-bearing subcarrier (upper band edge frequency in MHz (informative))	1 971 (8.5)	1 971 (8.5)	1 971 (8.5)	1 971 (8.5)	1 971 (8.5)	1 971 (8.5)	4 095 (17.660)	2 885 (24.890)
	Index of highest supported upstream data-bearing subcarrier (upper band edge frequency in MHz (informative))	1 205 (5.2)	1 205 (5.2)	1 205 (5.2)	1 205 (5.2)	2 782 (12)	2 782 (12)	2 782 (12)	3 478 (30)

Table 6-1 – VDSL2 profiles

Frequency plan	Parameter	Parameter value for profile							
		8a	8b	8c	8d	12a	12b	17a	30a
Annex B (997E)	Index of highest supported downstream subcarrier (upper band edge frequency in MHz (informative))	1 634 (7.05)	1 634 (7.05)	1 634 (7.05)	1 634 (7.05)	1 634 (7.05)	1 634 (7.05)	3 246 (14)	3 130 (27)
	Index of highest supported upstream subcarrier (upper band edge frequency in MHz (informative))	2 047 (8.832)	2 047 (8.832)	1 182 (5.1)	2 047 (8.832)	2 782 (12)	2 782 (12)	4 095 (17.660)	3 478 (30)
Annex B (HPE)	Index of highest supported downstream subcarrier (upper band edge frequency in MHz (informative))	N/A	N/A	N/A	N/A	N/A	N/A	4 095 (17.660)	3 478 (30)
	Index of highest supported upstream subcarrier (upper band edge frequency in MHz (informative))	N/A	N/A	N/A	N/A	N/A	N/A	3 246 (14)	2 885 (24.890)

Table 6-1 – VDSL2 profiles

Frequency plan	Parameter	Parameter value for profile							
		8a	8b	8c	8d	12a	12b	17a	30a
Annex C	Index of highest supported downstream subcarrier (upper band edge frequency in MHz (informative))	1 971 (8.5)	1 971 (8.5)	1 971 (8.5)	1 971 (8.5)	1 971 (8.5)	1 971 (8.5)	4 095 (17.660)	2 098 (18.1)
	Index of highest supported upstream subcarrier (upper band edge frequency in MHz (informative))	1 205 (5.2)	1 205 (5.2)	1 205 (5.2)	1 205 (5.2)	2 782 (12)	2 782 (12)	2 782 (12)	3 478 (30)
<p>NOTE 1 – The minimum aggregate transmit power values are for further study. These values may be provided in a later version of this Recommendation based on a consensus understanding of the power required to meet service objectives and practical implementation of line drivers.</p> <p>NOTE 2 – The allowed frequency band is determined by applicable PSD mask requirements defined in the annexes of this Recommendation, constrained by the capabilities guaranteed by the profile(s) that the implementation supports.</p> <p>NOTE 3 – The US0 frequency allocation is determined by applicable PSD mask requirements defined in the annexes to this Recommendation.</p> <p>NOTE 4 – D_{max} is derived from the aggregate interleaver and de-interleaver delay by dividing this amount by 32.</p>									

6.2 Profile parameter definitions

Each profile specifies normative values for the following parameters:

- The maximum aggregate transmit power in the downstream and upstream directions;
- The minimum aggregate transmit power in the downstream and upstream directions;
- The subcarrier spacing;
- Whether support of upstream band zero (US0) is required;
- The minimum bidirectional net data rate capability (MBDC);
- The aggregate interleaver and de-interleaver delay in octets;
- The index of the highest data-bearing subcarrier supported in the downstream and upstream directions (frequency plan dependent);
- Maximum interleaving depth; and
- Parameter $(1/S)_{max}$.

These parameters are explicitly defined in the following clauses.

6.2.1 Maximum aggregate downstream transmit power

To be compliant with a specific profile, the aggregate downstream transmit power of a VTU shall not exceed the value specified in the row labelled "maximum aggregate downstream transmit power" in Table 6-1.

6.2.2 Minimum aggregate downstream transmit power

For further study.

6.2.3 Maximum aggregate upstream transmit power

To be compliant with a specific profile, the aggregate upstream transmit power of a VTU shall not exceed the value specified in the row labelled "maximum aggregate upstream transmit power" in Table 6-1.

6.2.4 Minimum aggregate upstream transmit power

For further study.

6.2.5 Required subcarrier spacing

The subcarrier spacing is defined in clause 10.4.2. To be compliant with a profile, a VTU shall support the required subcarrier spacing specified in that profile.

6.2.6 Support of upstream band zero (US0)

This parameter specifies whether a compliant VTU is required to support upstream band zero (US0). A VTU-O compliant with a profile mandating support of US0 shall be capable of receiving US0. A VTU-R compliant with a profile mandating support of US0 shall be capable of transmitting US0.

If US0 is not supported, US0 shall be excluded from the upstream passband.

The frequency allocation for band US0 is defined in the regional annexes of this Recommendation.

6.2.7 Required minimum bidirectional net data rate capability (MBDC)

The bidirectional net data rate capability is the maximum value of the bidirectional net data rate that the VTU can support. The required minimum bidirectional net data rate capability (MBDC) is the minimum value of the bidirectional net data rate that a VTU compliant with a profile shall be capable of supporting.

6.2.8 Aggregate interleaver and de-interleaver delay

The required aggregate interleaver and de-interleaver delay is specified in terms of the sum of the end-to-end delays in the upstream and downstream directions over both latency paths, expressed in octets. Therefore, it involves both VTUs. Figure 6-1 illustrates an end-to-end connection with two latency paths and their interleavers and de-interleavers.

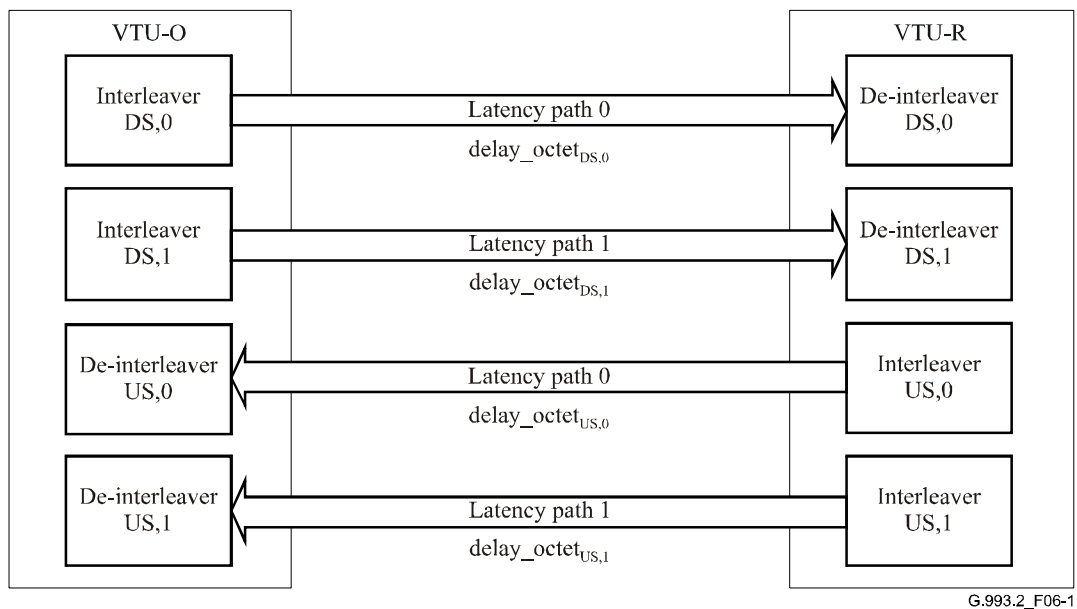

Figure 6-1 – Illustration of all latency paths composing the aggregate interleaver and de-interleaver delay specified in each profile

The end-to-end delay in octets for the interleaver and de-interleaver pair on path p , with $p = 0, 1$, is given by:

$$\text{delay_octet}_{x,p} = (I_{x,p} - 1) \times (D_{x,p} - 1)$$

where the direction of transmission x is either "DS" for downstream or "US" for upstream, $I_{x,p}$ is the interleaver block length, and $D_{x,p}$ is the interleaver depth.

Each interleaver and each de-interleaver for each latency path requires at least $(\text{delay_octet}_{x,p}/2)$ octets of memory to meet this delay. The actual amount of memory used is implementation specific.

Referring to Figure 6-1, the aggregate interleaver and de-interleaver delay is specified as the sum $\text{delay_octet}_{DS,0} + \text{delay_octet}_{DS,1} + \text{delay_octet}_{US,0} + \text{delay_octet}_{US,1}$,

which can be rewritten as:

$$\sum_p (I_{US,p} - 1) \cdot (D_{US,p} - 1) + (I_{DS,p} - 1) \cdot (D_{DS,p} - 1)$$

VTUs shall comply with the requirement

$$\sum_p (I_{US,p} - 1) \cdot (D_{US,p} - 1) + (I_{DS,p} - 1) \cdot (D_{DS,p} - 1) \leq \text{MAXDELAYOCTET}$$

where the summation is over all latency paths and MAXDELAYOCTET is the parameter "aggregate interleaver and de-interleaver delay", in octets, specified in Table 6-1 for the profile.

The minimum amount of memory required in a transceiver (VTU-O or VTU-R) to meet this requirement is $\frac{\text{MAXDELAYOCTET}}{2}$ octets. The actual amount of memory used is implementation specific.

6.2.9 Index of the highest supported downstream data-bearing subcarrier

The index of the highest supported downstream data-bearing subcarrier is a band plan dependent parameter. It specifies the index of the highest-frequency subcarrier available for downstream transmission. A VTU-O compliant with a profile shall be capable of transmitting data-bearing

subcarriers with indices up to (and including) the index specified in the profile under the heading "index of the highest supported downstream data-bearing subcarrier". The VTU shall not transmit data-bearing subcarriers with indices higher than this index.

NOTE – The upper band edge frequency from which the index of the highest downstream data-bearing subcarrier has been derived appears in parentheses after the subcarrier index. The upper band edge frequency is informative.

6.2.10 Index of the highest supported upstream data-bearing subcarrier

The index of the highest supported upstream data-bearing subcarrier is a band plan dependent parameter. It specifies the index of the highest-frequency subcarrier available for upstream transmission. A VTU-R compliant with a profile shall be capable of transmitting data-bearing subcarriers with indices up to (and including) the index specified in the profile under the heading "index of the highest supported upstream data-bearing subcarrier". The VTU shall not transmit data-bearing subcarriers with indices higher than this index.

NOTE – The upper band edge frequency from which the index of the highest upstream data-bearing subcarrier has been derived appears in parentheses after the subcarrier index. The upper band edge frequency is informative.

6.2.11 Maximum interleaving depth

The definition of the interleaving depth is in clause 9.4. To be compliant with a specific profile, a VTU shall be capable of providing interleaving depth up to and including the value of D_{max} specified in the row labelled "maximum interleaving depth (D_{max})" in Table 6-1.

6.2.12 Parameter $(1/S)_{max}$

Parameter $(1/S)_{max}$ defines the maximum number of FEC codewords that the VTU is capable of transmitting during one DMT symbol (see detailed definition in clause 9.5.5). To be compliant with a specific profile, the VTU shall be capable of transmitting up to and including $(1/S)_{max}$ FEC codewords, of any valid size, per DMT symbol, as specified in the rows labelled "parameter $(1/S)_{max}$ downstream" and "parameter $(1/S)_{max}$ upstream" in Table 6-1.

6.3 Profile compliance

To be compliant with a selected profile, a VTU-O shall:

- Be capable of transmitting subcarriers at the subcarrier spacing value specified in the profile;
- Be capable of transmitting data-bearing subcarriers with indices up to (and including) the index specified in the profile, for the applicable band plan, under the heading "index of the highest supported downstream data-bearing subcarrier";
- Be capable of receiving US0 if the profile mandates support of US0;
- Support the aggregate interleaver and de-interleaver delay in octets specified in the profile;
- Support all values of D up to and including D_{max} , both upstream and downstream;
- Support all values of $1/S$ up to and including $(1/S)_{max}$ upstream and $(1/S)_{max}$ downstream; and
- Support its MBDC.

To be compliant with a selected profile, a VTU-R shall:

- Be capable of transmitting subcarriers at the subcarrier spacing value specified in the profile;
- Be capable of transmitting data-bearing subcarriers with indices up to (and including) the index specified in the profile, for the applicable band plan, under the heading "index of the highest supported upstream data-bearing subcarrier";
- Be capable of transmitting US0 if the profile mandates support of US0;
- Support the aggregate interleaver and de-interleaver delay in octets specified in the profile;

- Support all values of D up to and including D_{max} , both upstream and downstream;
- Support all values of $1/S$ up to and including $(1/S)_{max}$ upstream and $(1/S)_{max}$ downstream; and
- Support its MBDC.

Furthermore, a VTU complying with a selected profile shall:

- Not use subcarrier spacing values not specified in the profile;
- Not transmit in a passband that includes subcarriers with indices higher than specified in the profile, for the applicable band plan and transmission direction, under the heading "index of the highest supported downstream (upstream) data-bearing subcarrier";
- Not use an aggregate interleaver and de-interleaver delay greater than the value specified in the profile; and
- Not transmit at a power level greater than the maximum aggregate transmitter power specified in the profile.

7 Transmission medium interface characteristics

This clause specifies the interface between the transceiver and the transmission medium U-O2 and U-R2 reference points as defined in clause 5.4. For the purposes of this Recommendation, the U-O2/U-R2 and U-O/U-R interfaces are considered spectrally equivalent.

7.1 Duplexing method and band plan construction

VDSL2 transceivers shall use frequency division duplexing (FDD) to separate upstream and downstream transmissions. Overlapping of the upstream and downstream passbands is not allowed. The allocation of the upstream and downstream frequency bands is defined by the band plan, which is specified by band-separating frequencies.

The VDSL2 signal can potentially utilize the frequency range up to 30 MHz, although the maximum frequency used by a VTU to transmit data depends on the selected band plan and the profile (see clause 6).

7.1.1 Band plan below 12 MHz

In the frequency range below 12 MHz, VDSL2 specifies the 5-band plan defined in Figure 7-1. The frequency band between f_{0L} and f_{0H} is denoted as US0. If used at all, this band shall be used only for upstream transmission. The four frequency bands denoted as DS1, US1, DS2, and US2, for the first downstream band, the first upstream band, the second downstream band, and the second upstream band, respectively, shall be defined by the band separating frequencies f_1, f_2, f_3, f_4 and f_5 , where $f_1 \geq f_{0H}$.

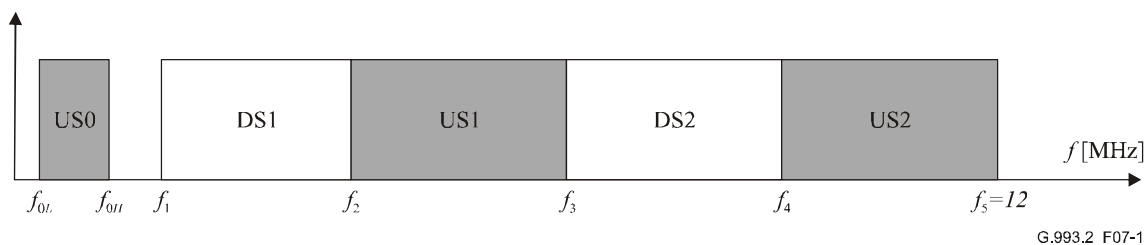

Figure 7-1 – Band plan in the frequency range up to 12 MHz

For the band plan below 12 MHz shown in Figure 7-1, the upstream passband shall be composed of the following portions of the frequency spectrum: $f_{0L} < f < f_{0H}$, $f_2 < f < f_3$, and $f_4 < f < f_5$. The downstream passband shall be composed of the following portions of the frequency spectrum: $f_1 < f < f_2$ and $f_3 < f < f_4$. The passband in each direction shall not contain frequencies above the frequency corresponding to the highest supported data-bearing subcarrier specified for that direction by the selected profile (6.1).

The values of f_{0L} , f_{0H} , f_1 , f_2 , f_3 , and f_4 are specified in Annexes A, B and C.

7.1.2 Band plan above 12 MHz

In the frequency range between 12 MHz and 30 MHz, VDSL2 specifies at least one additional downstream or upstream band. Bands above 12 MHz are specified by additional band separating frequencies. The number of additional band separating frequencies depends on the number of bands defined between 12 MHz and 30 MHz. Any values of band separating frequencies defined between 12 MHz and 30 MHz are specified in Annexes A, B and C.

When frequencies above 12 MHz are in use, the downstream (upstream) passband consists of the downstream (upstream) passband below 12 MHz plus any downstream (upstream) bands above 12 MHz. However, the passband in each direction shall not contain frequencies above the frequency corresponding to the highest supported data-bearing subcarrier specified for that direction by the selected profile (6.1).

7.2 Power spectral density (PSD)

7.2.1 Transmit PSD mask

A VTU shall confine the PSD of its transmit signal to be within the transmit PSD mask. The transmit PSD mask is the lesser, at every frequency, of the Limit PSD mask specified in the relevant annex and, if applicable, a MIB PSD mask specified by the service provider, which is provided to the VTUs via the MIB.

7.2.1.1 MIB PSD mask construction

This clause provides requirements and constraints for construction of the MIB PSD mask, which can be used to constrain the VDSL2 transmit PSD mask to levels lower than those specified by the Limit PSD masks. See Annexes A, B and C for specific Limit PSD masks defined for some geographic regions.

In this clause, the term "band" corresponds to an upstream or downstream frequency band of the band plan defined in the relevant annex. The term "frequency range" is used to indicate a part of such a band.

7.2.1.1.1 Overview

In some deployment scenarios, an operator may choose to force VTUs to transmit at levels lower than those specified by the Limit PSD masks. The MIB PSD mask is an additional tool that allows operators to shape the VTU-O and VTU-R transmit PSD masks. Power cut-back (see clause 12.3.3) and upstream power back-off (see clause 7.2.1.3) are tools that provide further reduction of the transmit PSD (below the transmit PSD mask).

The MIB PSD mask shall lie at or below the Limit PSD mask specified in the selected annex. Its definition shall be under the network management control (a MIB-controlled mechanism), as defined in [ITU-T G.997.1].

The MIB PSD mask shall be specified in the CO-MIB by a set of breakpoints. Up to 16 breakpoints may be specified to construct the MIB PSD mask for all utilized upstream bands (including US0), and up to 32 breakpoints may be specified to construct the MIB PSD mask for all utilized downstream bands. It is not required to specify breakpoints for every band defined by a band plan. In frequency

ranges in which the MIB PSD mask is not specified, the transmit PSD mask shall be equal to the Limit PSD mask.

Each breakpoint used to specify the MIB PSD mask shall consist of a subcarrier index t_n and a PSD mask value PSD_n at that subcarrier expressed in dBm/Hz. The subcarrier indices shall always be calculated assuming 4.3125 kHz subcarrier spacing (i.e., independent of the subcarrier spacing actually used – see Table 6-1).

Breakpoints for each utilized band shall be represented by the set $[(t_1, PSD_1), \dots, (t_n, PSD_n), \dots, (t_{NBP}, PSD_{NBP})]$. The first breakpoint shall have the value $t_1 = \text{ceil}(f_x/4.3125 \text{ kHz})$, where "ceil" denotes the ceiling function (rounding up to the nearest integer), and f_x is the frequency of the lower band edge (see Figure 7-1). The index t_1 corresponds to the lowest-frequency subcarrier in the band, assuming that a profile with 4.3125 kHz subcarrier spacing is used. Except for the US0 band, the last breakpoint in the band shall have the value $t_{NBP} = \text{floor}(f_{x+1}/4.3125 \text{ kHz})$, where "floor" denotes the floor function (rounding down to the nearest integer), and f_{x+1} is the frequency of the upper band edge. For the US0 band, the last breakpoint is specified in clause 7.2.1.1.3. The index t_{NBP} corresponds to the highest-frequency subcarrier in the band, assuming that a profile with 4.3125 kHz subcarrier spacing is used. Additional breakpoints within a band, if needed, shall be specified so that $t_n < t_{n+1}$ for $n = 2$ to $NBP - 1$. The frequency f_n corresponding to the index t_n is $f_n = t_n \times 4.3125 \text{ kHz}$.

All t_i in a particular frequency band shall be coded in the CO-MIB as unsigned integers.

The value of the PSD at subcarrier t_n , PSD_n , shall be coded in the CO-MIB as an unsigned integer. The PSD values shall be coded from 0 dBm/Hz (coded as 0) to -127.5 dBm/Hz (coded as 255), in steps of 0.5 dBm/Hz. The valid range of PSD values is from 0 dBm/Hz to -95 dBm/Hz , although the values input via the MIB must be no higher than allowed by the Limit PSD mask.

In the case that a profile specifying 8.625 kHz subcarrier spacing is used, the VTU shall subtract 1 from any odd values of t_i for $i = 2$ to $NBP - 1$. If t_1 is an odd number, the VTU shall add 1 to t_1 and use this value as the first breakpoint. If t_{NBP} is an odd number, the VTU shall subtract 1 from t_{NBP} and use this value as the last breakpoint.

The MIB PSD mask parameter in the CO-MIB shall be a concatenation of the sets of breakpoints for all utilized bands.

7.2.1.1.2 Definition of breakpoints above US0

Breakpoints specified in the CO-MIB at frequencies above f_1 shall comply with the restrictions specified in this clause.

7.2.1.1.2.1 Definition of breakpoints for PSD_n that are greater than or equal to -80 dBm/Hz

For all breakpoints with values of PSD_n in the MIB PSD mask that are greater than or equal to -80 dBm/Hz , the values of PSD_n shall be defined with the following restrictions, except for the steep upward shape defined in clause 7.2.1.1.2.3, which can be used to provide steeper upward MIB PSD mask transitions.

- For $t_n < t_{n+1}$, the slope of the MIB PSD mask levels shall comply with:

$$\left| \frac{PSD_{n+1} - PSD_n}{t_{n+1} - t_n} \right| \leq 0.75 \text{ dB/4.3125 kHz} \quad \text{for 4.3125 kHz subcarrier spacing}$$

$$\left| \frac{PSD_{n+1} - PSD_n}{t_{n+1} - t_n} \right| \leq 0.375 \text{ dB/4.3125 kHz} \quad \text{for 8.6250 kHz subcarrier spacing}$$

- $\min(PSD_n) \geq -80 \text{ dBm/Hz}$, and $\max(PSD_n) - \min(PSD_n) \leq 40 \text{ dB}$, where $\max(PSD_n)$ denotes the maximum and $\min(PSD_n)$ denotes the minimum of all breakpoint PSD values at or above -80 dBm/Hz .

The MIB PSD mask at an arbitrary frequency f shall be obtained by interpolation in dB on a linear frequency scale as follows:

$$\text{MIBPSD mask}(f) = \text{PSD}_n + (\text{PSD}_{n+1} - \text{PSD}_n) \times \frac{(f/4.3125\text{kHz}) - t_n}{t_{n+1} - t_n}, t_n < (f/4.3125\text{ kHz}) \leq t_{n+1}$$

Figure 7-2 illustrates the MIB PSD mask in the case that all breakpoints are above -80 dBm/Hz (with $\min(\text{PSD}_n) = \text{PSD}_5$ and $\max(\text{PSD}_n) = \text{PSD}_3$).

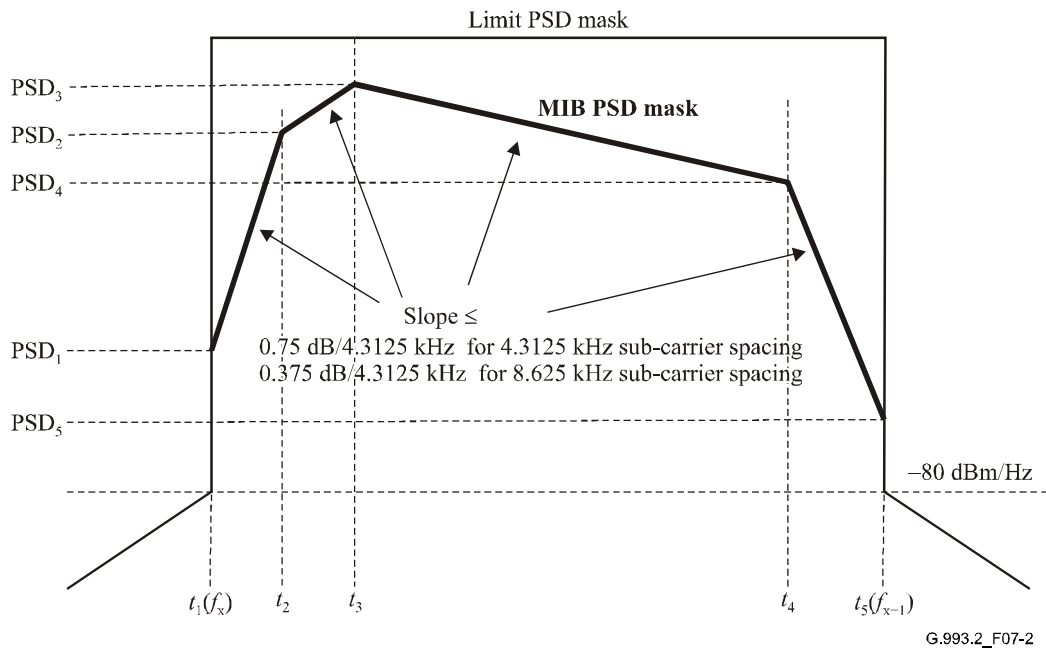

Figure 7-2 – Illustration of a MIB PSD mask in the case all breakpoint PSD_n values are greater than -80 dBm/Hz

7.2.1.1.2.2 Definition of breakpoints when some PSD_n values are less than -80 dBm/Hz

An operator may wish to specify a MIB PSD mask with some PSD_n values that are below -80 dBm/Hz within a band (between t_1 and t_{NBP}) and with one frequency range from t_{start} to t_{stop} in which the MIB PSD mask is greater than -80 dBm/Hz . Such a case is illustrated in Figure 7-3. In this case, the MIB PSD mask breakpoint values PSD_n in the ranges $t_1 \leq t < t_{start}$ and $t_{stop} < t \leq t_{NBP}$ shall be set no lower than the stopband PSD requirements defined in clause 7.2.2, where the low-edge and high-edge transition frequencies of the frequency range with the MIB PSD mask greater than -80 dBm/Hz are $f_{rx2} = t_{start} \times 4.3125\text{ kHz}$ and $f_{rx1} = t_{stop} \times 4.3125\text{ kHz}$, respectively.

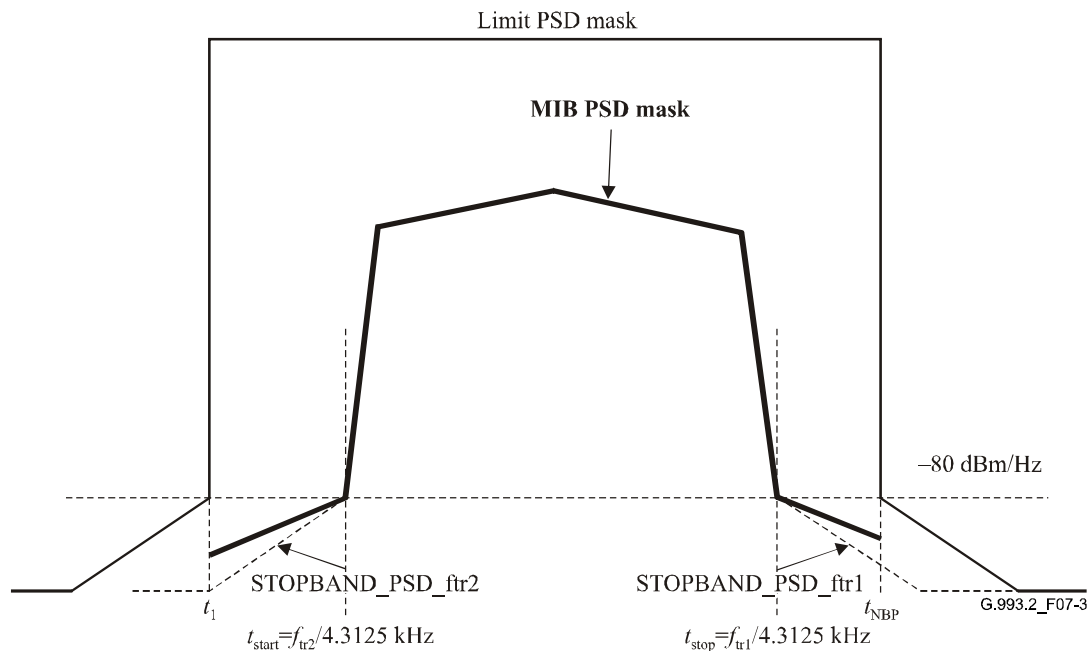

Figure 7-3 – Illustration of the restrictions on breakpoints for a case in which the MIB PSD mask lies below -80 dBm/Hz between two band separating frequencies (t_1 and t_{NBP}) but above -80 dBm/Hz for some frequency range inside the band

Alternatively, an operator may wish to specify a MIB PSD mask which is below -80 dBm/Hz in a frequency range that lies between two frequency ranges in which the MIB PSD mask is greater than -80 dBm/Hz. For example, the MIB PSD mask is above -80 dBm/Hz in the range t_{start1} to t_{stop1} (range 1) and from t_{start2} to t_{stop2} (range 2), and from t_{stop1} to t_{start2} it is below -80 dBm/Hz, as illustrated in Figure 7-4. In this case, the MIB PSD mask breakpoint values PSD_n for indices $t_{stop1} < t < t_{start2}$ shall be set not lower than the power sum of the high-edge stopband PSD of range 1 and the low-edge stopband PSD of range 2 (see clause 7.2.2), with the high-edge transition frequency of range 1 equal to $f_{tr1} = t_{stop1} \times 4.3125$ kHz and the low-edge transition frequency of range 2 equal to $f_{tr2} = t_{start2} \times 4.3125$ kHz, respectively. The power sum can be calculated using the following equation:

$$\text{MIB PSD mask } (t_{stop1} < t < t_{start2}) \geq 10 \times \log_{10} (10^{0.1 \times \text{STOPBAND_PSD_ftr1}(t)} + 10^{0.1 \times \text{STOPBAND_PSD_ftr2}(t)})$$

NOTE – The power sum may result in PSD levels higher than -80 dBm/Hz.

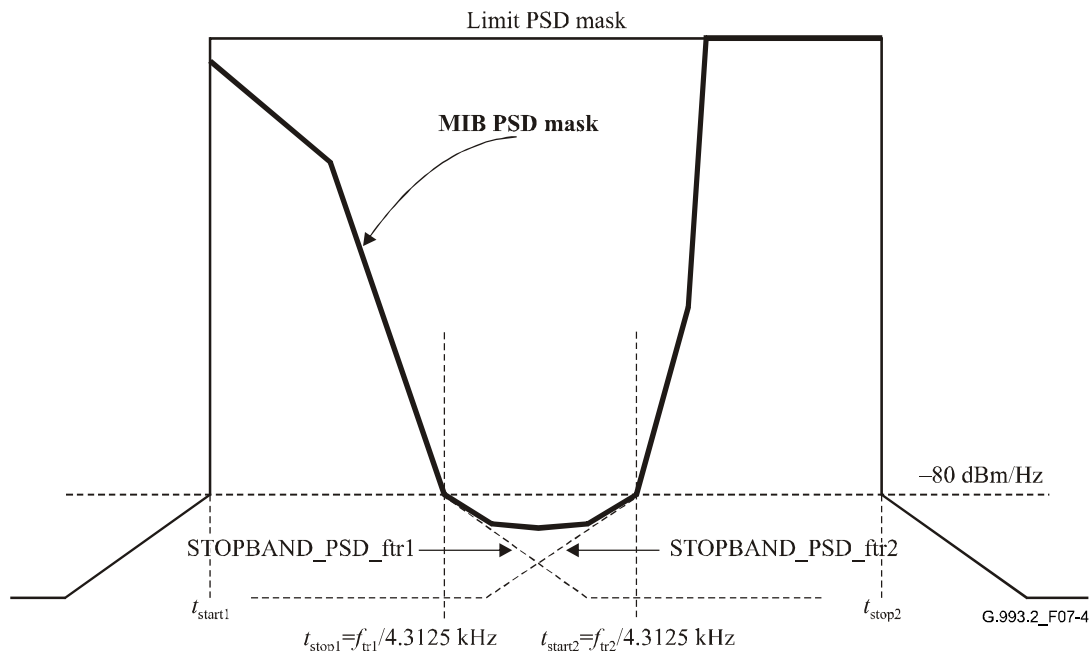

Figure 7-4 – Illustration of the restrictions on breakpoints for a frequency band in which the MIB PSD lies below -80 dBm/Hz between two frequency ranges where the PSD is above -80 dBm/Hz

7.2.1.1.2.3 Definition of the step upward shape

It is possible to utilize a single step upward shape to construct the MIB PSD mask. The selected step upward shape can be used to achieve steeper slope in the MIB PSD mask definition than that specified in clause 7.2.1.1.2.1. Two valid step upward shapes are specified. Only one of them may be used in the construction of the MIB PSD mask.

7.2.1.1.2.3.1 One-slope step upward shape

The one-slope step upward shape is defined as:

- $-80 \text{ dBm/Hz} \leq \text{PSD}_i < -60 \text{ dBm/Hz}$;
- $\text{PSD}_{i+1} \leq -60 \text{ dBm/Hz}$;
- $\text{PSD}_j \leq \text{PSD}_{i+1}$ for all $j > (i+1)$;
- $\left| \frac{\text{PSD}_{i+1} - \text{PSD}_i}{t_{i+1} - t_i} \right| \leq 2.86 \text{ dB} / 4.3125 \text{ kHz}$ for 4.3125 kHz subcarrier spacing;
- $\left| \frac{\text{PSD}_{i+1} - \text{PSD}_i}{t_{i+1} - t_i} \right| \leq 1.43 \text{ dB} / 4.3125 \text{ kHz}$ for 8.6250 kHz subcarrier spacing.

NOTE – These slopes correspond approximately to a maximum of 20 dB increase in the PSD mask level over seven subcarriers.

The one-slope steep upward shape is illustrated in Figure 7-5.

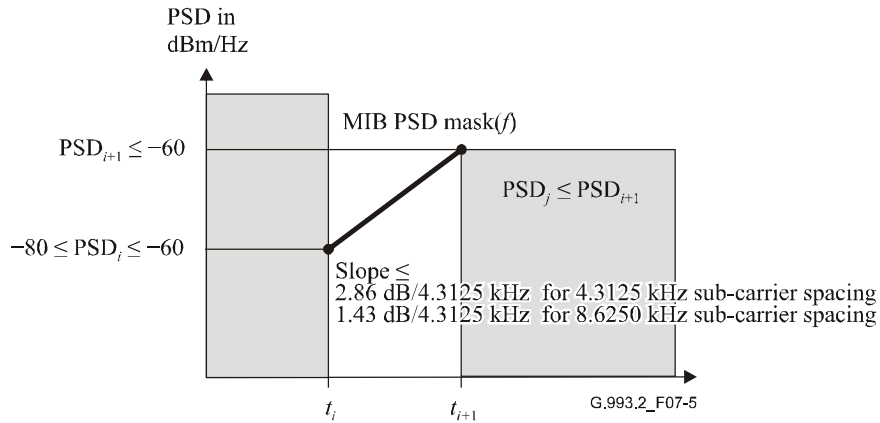

Figure 7-5 – Illustration of the one-slope steep upward shape

7.2.1.1.2.3.2 Two-slope steep upward shape

The two-slope steep upward shape is defined as:

- $-80 \text{ dBm/Hz} \leq \text{PSD}_i < -60 \text{ dBm/Hz}$;
- $\text{PSD}_{i+2} \leq -36.5 \text{ dBm/Hz}$;
- $\text{PSD}_j \leq \text{PSD}_{i+2}$ for all $j > (i + 2)$;
- If $\text{PSD}_i > -80 \text{ dBm/Hz}$ then it is required that $\text{PSD}_k \geq \text{PSD}_i$ for all $k < i$;
- $\left| \frac{\text{PSD}_{i+1} - \text{PSD}_i}{t_{i+1} - t_i} \right| \leq 0.50 \text{ dB/4.3125 kHz}$ for 4.3125 kHz subcarrier spacing;
- $\left| \frac{\text{PSD}_{i+1} - \text{PSD}_i}{t_{i+1} - t_i} \right| \leq 0.25 \text{ dB/4.3125 kHz}$ for 8.6250 kHz subcarrier spacing;

with $(t_{i+1} - t_i) \leq 47$.

- $\left| \frac{\text{PSD}_{i+2} - \text{PSD}_{i+1}}{t_{i+2} - t_{i+1}} \right| \leq 2.86 \text{ dB/4.3125 kHz}$ for 4.3125 kHz subcarrier spacing;
- $\left| \frac{\text{PSD}_{i+2} - \text{PSD}_{i+1}}{t_{i+2} - t_{i+1}} \right| \leq 1.43 \text{ dB/4.3125 kHz}$ for 8.6250 kHz subcarrier spacing;

with $(t_{i+2} - t_{i+1}) \leq 7$.

NOTE – These slopes correspond approximately to a maximum of 23 dB increase in the PSD mask level over 47 subcarriers, and 20 dB over seven subcarriers.

The two-slope steep upward shape is illustrated in Figure 7-6.

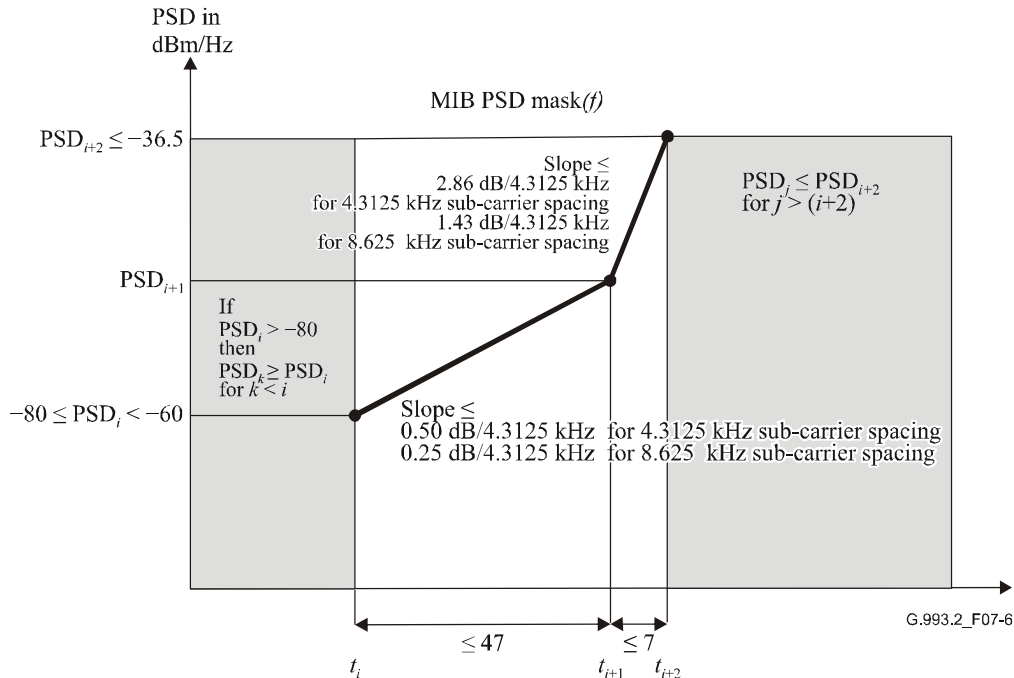

Figure 7-6 – Illustration of the two-slope steep upward shape

7.2.1.1.2.4 Definition of breakpoints at the edge of a band

No additional restrictions on the MIB PSD mask are imposed at the band edges. The values PSD_1 and PSD_{NBP} can be any value between the value of the Limit PSD mask at that frequency and -95 dBm/Hz, provided that the MIB PSD mask construction rules are not violated as a result.

7.2.1.1.3 Definition of breakpoints in US0

If US0 shaping is supported, breakpoints $[(t_1, PSD_1), \dots, (t_n, PSD_n), \dots, (t_{NBPUS0}, PSD_{NBPUS0})]$ specified in the CO MIB at frequencies between f_{0L} and f_{0H} ($f_{0L} \leq t_n \times 4.3125 \text{ kHz} \leq f_{0H}$) shall comply with the restrictions specified in the following clauses.

7.2.1.1.3.1 Restriction on breakpoints in US0

The number of breakpoints in US0 (NBP_{US0}) shall be between 2 and 6. The first breakpoint t_1 shall be equal to $\text{ceil}(f_{0L}/4.3125 \text{ kHz})$. The last breakpoint, t_{NBPUS0} , shall be smaller than or equal to $\text{floor}(f_{0H}/4.3125 \text{ kHz})$. t_{NBPUS0} shall be between 32 and 128. If $32 \leq t_{NBPUS0} \leq 64$, t_{NBPUS0} shall be a multiple of 4. If $64 < t_{NBPUS0} \leq 128$, t_{NBPUS0} shall be a multiple of 8.

The breakpoint PSD values PSD_n shall be specified according to the following constraints and requirements:

- 1) The range between the minimum and maximum PSD values over all breakpoints shall be no greater than 24 dB, i.e.,

$$\max\{PSD_n\} - \min\{PSD_n\} \leq 24 \text{ dB},$$

where:

$$\max\{PSD_n\} = \max(PSD_1, PSD_2, \dots, PSD_{NBP_{US0}}) \text{ and:}$$

$$\min\{PSD_n\} = \min(PSD_1, PSD_2, \dots, PSD_{NBP_{US0}})$$

2) The maximum slope between consecutive breakpoints shall be bound by at least one of the following two restrictions:

i) $\forall n : 1 < n < NBP_{US0} :$

$$\left| \frac{PSD_n - PSD_{n-1}}{t_n - t_{n-1}} \right| \leq 0.75 \text{ dB}/4.3125 \text{ kHz}$$

ii) $\forall n : 1 < n < NBP_{US0}$ and $(\max \{PSD_n\} - PSD_n \leq 6 \text{ dB}$ or $\max \{PSD_n\} - PSD_{n-1} \leq 6 \text{ dB})$:

$$\left| \frac{PSD_n - PSD_{n-1}}{t_n - t_{n-1}} \right| \leq 0.6 \text{ dB}/4.3125 \text{ kHz}$$

7.2.1.1.3.2 Derivation of US0 PSD mask from defined breakpoints

The MIB PSD mask at an arbitrary frequency f between $t_1 \times 4.3125 \text{ kHz}$ and $t_{NBP_{US0}} \times 4.3125 \text{ kHz}$ shall be obtained by interpolation in dB on a linear frequency scale as follows:

$$\text{MIB PSD mask } (f) = PSD_n + (PSD_{n+1} - PSD_n) \times \frac{(f/4.3125 \text{ kHz}) - t_n}{t_{n+1} - t_n}, t_n < (f/4.3125 \text{ kHz}) \leq t_{n+1}$$

For frequencies below $t_1 \times 4.3125 \text{ kHz}$, the MIB PSD mask shall be equal to PSD_1 .

For $t_{NBP_{US0}} \times 4.3125 \text{ kHz} < f < 989 \text{ kHz}$, the MIB_PSD_mask in dBm/Hz shall be the higher of:

$$\text{MIB_PSD_Mask}(f) = PSD_{NBP_{US0}-1} - 72 \times \log_2((f/4.3125 \text{ kHz})/t_{NBP_{US0}-1})$$

and:

$$\text{MIB_PSD_Mask}(f) = \max(-100 - 15 \times \log_{10}(f/686 \text{ kHz}) - 100)$$

7.2.1.2 Egress control

VDSL2 transmitters shall be able to reduce the PSD of the transmitted signal to a level below -80 dBm/Hz in 16 arbitrary frequency bands simultaneously. An example list of frequency bands (the amateur radio bands) is shown in Table 7-1. The value of -80 dBm/Hz shall be accounted for in the determination of MREFMASK (see Tables 7-3 through 7-5).

Table 7-1 – Amateur radio bands

Band start (kHz)	Band stop (kHz)
1 800	2 000
3 500	4 000
7 000	7 300
10 100	10 150
14 000	14 350
18 068	18 168
21 000	21 450
24 890	24 990
28 000	29 700

The specific RFI bands to be notched are configured in the CO-MIB by the operator and set during the ITU-T G.994.1 handshake phase of initialization (see clause 12.3.2).

The egress control parameters specified in [ITU-T G.997.1] are the start and stop frequencies of each frequency band in which the transmit PSD shall be reduced to a level below -80 dBm/Hz. The PSD slopes forming the notch are vendor discretionary.

7.2.1.3 Upstream power back-off (UPBO)

Upstream power back-off (UPBO) shall be performed by the VTU-R to improve spectral compatibility between VDSL2 systems on loops of different lengths deployed in the same binder. This UPBO mechanism does not apply during the ITU-T G.994.1 handshake phase. In addition, UPBO for US0 is for further study.

7.2.1.3.1 Power back-off mechanism

The VTU-R transmit PSD shall be reduced in a frequency-dependent manner using the procedure defined below:

- The transmit PSD mask, PSDMASK_{us}, for the VTU-R shall be calculated by the VTU-O to comply with settings from the network management system as defined in clause 7.2.1. PSDMASK_{us} is communicated to the VTU-R at the beginning of initialization (in O-SIGNATURE).
- The VTU-R shall perform UPBO as described in clause 7.2.1.3.2 autonomously, i.e., without sending any significant information to the VTU-O until the UPBO is applied.
- After UPBO has been applied, the VTU-O shall be capable of adjusting the transmit PSD selected by the VTU-R; the adjusted transmit PSD shall be subject to the limitations given in clause 7.2.1.3.2.

7.2.1.3.2 Power back-off PSD mask

The VTU-R shall explicitly estimate the electrical length of its loop, kl_0 , optionally kl_0 per band (i.e., $kl_0[band]$), and use this value to calculate the UPBO PSD mask, UPBOMASK, at the beginning of initialization. The VTU-R shall then adapt its transmit signal to conform strictly to the mask UPBOMASK(kl_0, f) during initialization and Showtime, while remaining below the PSDMASK_{us} limit determined by the VTU-O as described in clause 7.2.1.3.1, and within the limit imposed by the upstream PSD ceiling (CDMAXMASK_{us}, MAXMASK_{us}).

Two methods for upstream power back-off method are defined:

- the Reference PSD UPBO method;
- the Equalized FEXT UPBO method (optional).

The VTU-C and VTU-R shall support the reference PSD UPBO method, and may support the equalized FEXT UPBO method. If the equalized FEXT UPBO method is supported, it shall be supported for all upstream bands (except US0). This latter method is controlled via the parameter UPBO reference electrical length kl_{0_REF} , which is specified for each upstream band (see Table 12-25).

7.2.1.3.2.1 Electrical length estimation method

Two methods are defined for deriving the electrical length autonomously:

- ELE-M0 the default method
- ELE-M1 the alternative method

Implementation of ELE-M0 is mandatory. Implementation of ELE-M1 is optional.

The ELE-M1 shall be used if the CO-MIB parameter "Alternative Electrical Length Estimation Mode" (AELE-MODE) is set to a value of 1 or higher, and the mode is supported by the VTU-O and by the VTU-R. Otherwise, the ELE-M0 shall be used.

The actual AELE-MODE used shall be reported in the CO-MIB parameter "Actual Alternative Electrical Length Estimation Mode" (ACT-AELE-MODE). If the VTU-O supports the optional ELE-M1 and the ELE-M0 is used, then the ACT-AELE-MODE parameter shall be set to a value of 0.

7.2.1.3.2.1.1 The default electrical length estimation method (ELE-M0)

The ELE-M0 method is implementation dependent.

NOTE – A possible estimate of kl_0 is as follows:

$$kl_0 = \text{MIN}\left(\frac{\text{loss}(f)}{\sqrt{f}}\right) \text{ dB}$$

where the minimum is taken over the usable VDSL2 frequency band above 1 MHz. The function $\text{loss}(f)$ is the insertion loss in dB of the loop at frequency f . This definition is abstract, implying an infinitely fine grid of frequencies.

7.2.1.3.2.1.2 The alternative electrical length estimation method (ELE-M1)

The ELE-M1 method is applied in the VTU-R to separately estimate the electrical length, in each downstream band, and in the VTU-O to separately estimate the electrical length, in each upstream band, excluding US0:

$$ELE[band] = \text{PERCENTILE}\left(\left\{\frac{\text{loss}(f, rx_thresh(band))}{\sqrt{f}} \mid f \in band\right\}, UPBOELMT\right) [dB]$$

Where:

1. $band \in \{aele_bands\}$, where $\{aele_bands\}$ is the set of all supported upstream and downstream bands except US0, and $f > 1.8 \times f_1$ for DS1.

NOTE 1 – $1.8 \times f_1$ is used as the lower limit in calculations on the basis that for most cables above this frequency the \sqrt{f} approximation is sufficiently accurate for the purposes of UPBO, and is sufficiently above the US0-DS1 boundary to limit the impact of DS1 high pass filtering. Compared to the use of 1 MHz, this frequency makes it less likely that in-premises bridge taps will have a large effect on the electrical length estimate $ELE[DS1]$.

2. $\text{loss}(f, rx_threshold(band))$ is the estimated transmission path loss in dB at tone frequency f in MHz, which is set to the special value 307.1 dB if the minimum received signal plus noise power during loss estimation is less than $rx_threshold$ (dBm/Hz) for the particular $band$.

The maximum values for $rx_threshold(band)$ are: –130 dBm/Hz in the downstream bands, and –115 dBm/Hz in the upstream bands. However, the VTU may use lower threshold $rx_threshold(band)$ settings. The actual threshold used shall be reported in CO-MIB parameters RXTHRSHDS and RXTHRSUS.

3. The $\text{PERCENTILE}(\{x\}, y)$ function returns the maximum value w in set $\{x\}$ such that the number of elements in $\{x\}$ with value less than w is less than y percent of the total number of elements in $\{x\}$.
4. UPBO Electrical Length Minimum Threshold (UPBOELMT) is a CO-MIB parameter which determines the percentile to be used in finding the qualified minimum of a set of frequency dependent electrical length estimates in a particular VDSL2 band.

NOTE 2 – The PERCENTILE function is used to mitigate the effect of RFI ingress. It provides an estimate of the minimum of a set of per-tone electrical length estimates, ignoring a small proportion of tones affected by high level narrow band RFI ingress.

If ELE-M1 is applied, the same value for kl_0 (*ELEDS*) is applied in all upstream bands except US0, at the beginning of initialisation. This is derived from $ELE[band]$ values estimated in the VTU-R for all downstream bands:

$$ELEDS = MIN(ELE[band]), \text{ where } band \in \{ds_bands\}$$

and

$$kl_0[us_band] = ELEDS \text{ for all } us_band \in \{upbo_bands\}$$

where $\{ds_bands\}$ is the set of all supported downstream bands with $f > 1.8 \times f_1$ for DS1, and $us_band \in \{upbo_bands\}$ the set of all supported upstream bands except US0.

The intermediate value ELEDS is sent to the VTU-O as "Estimate of electrical length" in R-MSG-1, as defined in clause 12.3.3.2.2.1.

An intermediate value ELEUS is determined in the VTU-O as follows:

$$ELEUS = MIN(ELE[band]), \text{ where } band \in \{upbo_bands\}.$$

The final electrical length is determined during initialisation and sent from the VTU-O to the VTU-R during initialisation in the O-UPDATE message (see clause 12.3.3.2.1.2). Separate values are provided for each upstream band, excluding US0. The values are selected according to the CO-MIB parameter AELE-MODE:

For all upstream bands except US0, $band \in \{upbo_bands\}$

AELE-MODE = 0 $kl_0[band] = \text{ELE-M0 VTU-O } kl_0 \text{ estimate}$

AELE-MODE = 1 $kl_0[band] = ELEDS \text{ [dB], } band \in \{upbo_bands\}$

AELE-MODE = 2 $kl_0[band] = ELE[band] \text{ [dB], } band \in \{upbo_bands\}$

AELE-MODE = 3 $kl_0[band] = MIN(ELEUS, ELEDS) \text{ [dB], } band \in \{upbo_bands\}$

If the CO-MIB parameter *UPBOKLF* (*Force CO-MIB electrical length*) is set to 1 then the final electrical length is set defined by the CO-MIB parameter *UPBOKL* (*Upstream electrical length*), and applied as follows:

$$kl_0[band] = UPBOKL, \text{ } band \in \{upbo_bands\}$$

If ELE-M1 is supported the following parameters shall be reported by the transceivers, whether or not *UPBOKLF* is set:

$ELE[band]$, $band \in \{ds_bands\}$ shall be reported by the VTU-R to the VTU-O in the R-MSG 1 message (see clause 12.3.3.2.2.1)

$ELE[band]$, $band \in \{aele_bands\}$ shall be reported by the VTU-O via the CO-MIB, where $\{aele_bands\} = \{ds_bands\} \cup \{upbo_bands\}$.

7.2.1.3.2.2 UPBO mask

If the optional equalized FEXT UPBO method is not supported, or if the optional equalized FEXT UPBO method is supported but $kl_0_{REF} = 0$ for a given upstream band, the UPBOMASK for that given band is calculated as:

$$UPBOMASK(kl_0, f) = UPBOPSD(f) + LOSS(kl_0, f) + 3.5 \text{ [dBm/Hz]},$$

where:

$$LOSS(kl_0, f) = kl_0 \sqrt{f} \text{ [dB], and}$$

$$UPBOPSD(f) = -a - b \sqrt{f} \text{ [dB/Hz]},$$

with f expressed in MHz.

In case ELE-M0 is used, kl_0 is defined as a single value.

In case ELE-M1 is used, kl_0 is defined separately for each band in $\{ upbo_bands \}$, i.e., $kl_0[band]$.

UPBOPSD(f) is a function of frequency but is independent of length and type of loop.

If the optional equalized FEXT UPBO method is supported, and $kl_{0_REF} \neq 0$ for a given upstream band, the UPBOMASK for that given band is calculated as:

- for ($1.8 \leq kl_0 < kl_{0_REF}$):

$$UPBOMASK(f) = -a - b\sqrt{f} + 10\log_{10}\left(\frac{kl_{0_REF}}{kl_0}\right) + LOSS(kl_0, f) + 3.5 \quad [\text{dBm/Hz}]$$

- for ($kl_0 < 1.8$):

$$UPBOMASK(f) = -a - b\sqrt{f} + 10\log_{10}\left(\frac{kl_{0_REF}}{1.8}\right) + LOSS(1.8, f) + 3.5 \quad [\text{dBm/Hz}]$$

- for ($kl_0 \geq kl_{0_REF}$):

$$UPBOMASK(f) = -a - b\sqrt{f} + LOSS(kl_0, f) + 3.5 \quad [\text{dBm/Hz}]$$

where:

$$LOSS(kl_0, f) = kl_0\sqrt{f} \quad [\text{dB}]$$

with f expressed in MHz.

For both methods of UPBO, the values of a and b , which may differ for each upstream band, are obtained from the CO-MIB as specified in [ITU-T G.997.1] and shall be provided to the VTU-R during initialization (see clause 12.3.3.2.1.1). Specific values may depend on the geographic region (see Annexes A, B and C).

For the optional equalized FEXT UPBO method, the value kl_{0_REF} is obtained from the CO-MIB as specified in [ITU-T G.997.1] and shall be provided to the VTU-R during initialization (see clause 12.3.3.2.1.1).

If the estimated value of kl_0 is smaller than 1.8, the VTU shall be allowed to perform power back-off as if kl_0 were equal to 1.8. The estimate of the electrical length should be sufficiently accurate to avoid spectrum management problems and additional performance loss.

NOTE 1 – To meet network specific requirements, network management may provide a means to override the VTU-R's autonomous estimate of kl_0 (see clause 12.3.3.2.1.2, O-UPDATE).

NOTE 2 – The nature of coupling between loops in a cable binder results in a rapidly decreasing FEXT as the loop length decreases. As the electrical length kl_0 of the loop decreases below 1.8, no further increase in power back-off is needed. An electrical length of 1.8 corresponds to, for example, a 0.4 mm loop about 70 m long.

7.2.2 Stopband PSD

The PSD of the signal transmitted in the stopbands shall comply with a Limit PSD Mask and a wide-band power limit as defined in Figure 7-7. The Limit PSD Mask applies between band separating frequencies f_{ir1} and f_{ir2} . The wide-band power limit P_{max} applies in that part of the band lying between the transition bands (width Δf_T).

The width of the transition bands Δf_T shall be independent of frequency and shall not exceed 175 kHz. Transition bands and values of the stopband PSD in the frequency range $f_{ir} < 686$ kHz are specified in regional annexes.

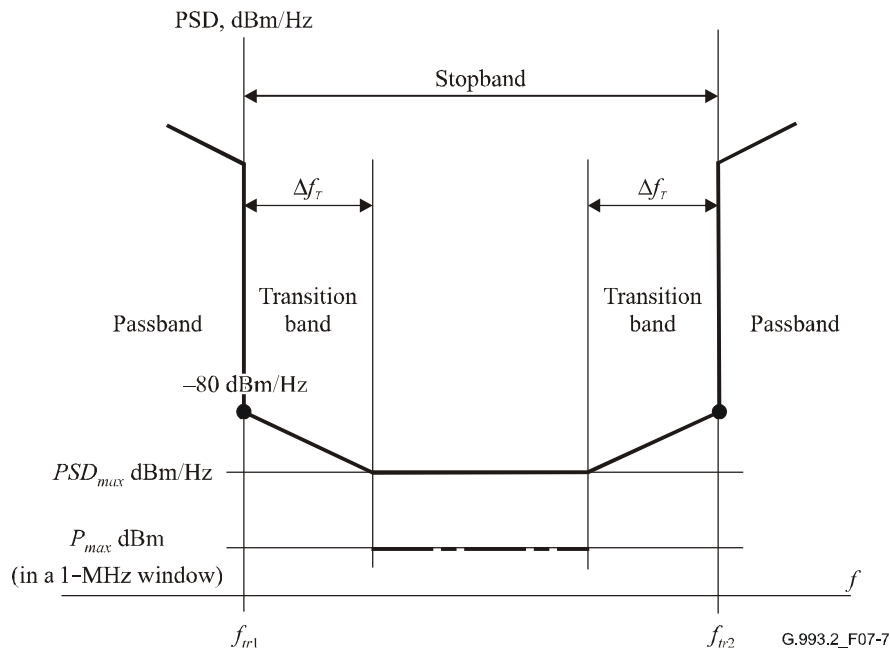

Figure 7-7 – Limit PSD mask and wide-band power limit in the stopbands

The Limit PSD mask values and the power limit values inside the stopbands shall be as listed in Table 7-2 and shown in Figure 7-7. The values between the points listed in Table 7-2 shall be found using linear interpolation over a linear scale of frequency. The signal transmitted in the stopbands shall comply with both the Limit PSD mask (verified using a 10 kHz measurement bandwidth) and the power limit in a 1-MHz sliding window presented in Table 7-2.

Table 7-2 – Stopband PSD requirements

Frequency (MHz)	Limit PSD mask value (PSD _{max} dBm/Hz)	Maximum power in a 1 MHz sliding window (P _{max} dBm)
< 0.686	Subject to regional annexes	
0.686-4.0	-100	
4.0-5.0	-100	-50
5.0-30.0	-100	-52
≥ 30.0	-110	
Frequency (MHz)	Limit PSD mask value at the transition frequency (dBm/Hz)	
Transition frequency (f = f _{ir1} and f = f _{ir2})	-80	

The power measured in any 1 MHz window [f, f+1 MHz] with $f \geq f_{ir1} + \Delta f_T$ and $f + 1 \text{ MHz} \leq f_{ir2} - \Delta f_T$ shall comply with the value shown in Table 7-2 (with f_{ir1} , f_{ir2} and Δf_T as shown in Figure 7-7). If the value $(f_{ir2} - f_{ir1} - 2\Delta f_T)$, is less than 1 MHz, the bandwidth of the measurement device should be reduced and set to Δf_M , so that $\Delta f_M \leq f_{ir2} - f_{ir1} - 2\Delta f_T$. The measured result shall be recalculated to the 1 MHz sliding window as:

$$P_{max} = P - 10 \times \log_{10} (\Delta f_M)$$

where:

P is the measured result in dBm

Δf_M is the bandwidth used for the measurement in MHz.

7.2.3 PSD and PSD mask summary

A summary of the various PSDs and PSD masks used during initialization and showtime is presented in Table 7-3.

Table 7-3 – PSD masks and PSDs used in this Recommendation

Parameter	Description	Notation
Limit PSD mask	A PSD mask specified in an annex of this Recommendation (Annex A, B, or C).	LIMITMASKds, LIMITMASKus
MIB PSD mask	A PSD mask specified by the operator for passbands only and intended to restrict the transmit PSD to levels below those allowed by the applicable Limit PSD mask.	MIBMASKds, MIBMASKus
Transmit PSD mask	A PSD mask that is the minimum of 1) the applicable Limit PSD mask, 2) the MIB PSD mask, and 3) vendor-discretionary mask restrictions imposed by the VTU-O.	PSDMASKds, PSDMASKus
UPBO PSD mask	A PSD mask, for the upstream direction only, which is calculated by the VTU-R as a function of the electrical length of the loop (see clause 7.2.1.3.2).	UPBOMASK
Channel discovery PSD	The PSD of signals transmitted by a VTU during the channel discovery phase of initialization.	CDPSDds, CDPSDus
PSD ceiling	A PSD level, independent of frequency (and indicated by a single value), that limits the transmit PSD mask to form the MEDLEY reference PSD mask. (see clauses 12.3.3.2.1.1, 12.3.3.2.1.2, 12.3.3.2.2.1, and 12.3.3.2.2.2).	CDMAXMASKds, CDMAXMASKus, MAXMASKds, MAXMASKus
MEDLEY reference PSD mask	The transmit PSD mask limited at every frequency by the PSD ceiling and to -80 dBm/Hz inside the RFI bands. In the upstream direction, also limited in accordance with the UPBO requirements.	MREFMASKds, MREFMASKus
MEDLEY reference PSD	The PSD of signals transmitted by a VTU during the training phase and the channel analysis and exchange phase of initialization.	MREFPSDds, MREFPSDus
Showtime PSD	The PSD of signals transmitted by a VTU during showtime.	PSDds PSDus

The details of computation rules for the PSD masks and setting rules for the PSDs are presented in Table 7-4.

Table 7-4 – Summary of PSD and PSD mask calculations

Parameter	Calculation
Transmit PSD mask (PSDMASK)	Calculated by the VTU-O as (Note): $PSDMASK_{ds}(f) = \min(LIMITMASK_{ds}(f), MIBMASK_{ds}(f), ds_mask_restrictions_by_VTU-O)$ $PSDMASK_{us}(f) = \min(LIMITMASK_{us}(f), MIBMASK_{us}(f), us_mask_restrictions_by_VTU-O)$
Channel Discovery PSD (CDPSD)	CDPSD _{ds} , expressed in dBm/Hz, is determined by the VTU-O, and for subcarriers from the SUPPORTEDCARRIERS _{ds} set: $CDPSD_{ds}(f) \leq \begin{cases} \min[(PSDMASK_{ds}(f) - 3.5), (CDMAXMASK_{ds} - 3.5)], f \notin RFIBANDS \\ \min[(PSDMASK_{ds}(f) - 3.5), (CDMAXMASK_{ds} - 3.5) - 83.5], f \in RFIBANDS \end{cases}$ For all other subcarriers, $CDPSD_{ds}(f) \leq PSDMASK_{ds}(f)$. For any valid setting of CDPSD _{ds} , the aggregate downstream transmit power shall not exceed the MAXNOMATP _{ds} . CDPSD _{us} , expressed in dBm/Hz, is determined by the VTU-R, and for subcarriers from the SUPPORTEDCARRIERS _{us} set: $CDPSD_{us}(f) \leq \begin{cases} \min[(PSDMASK_{us}(f) - 3.5), (CDMAXMASK_{us} - 3.5), (UPBOMASK(kl_o, f) - 3.5)], f \notin RFIBANDS \\ \min[(PSDMASK_{us}(f) - 3.5), (CDMAXMASK_{us} - 3.5), (UPBOMASK(kl_o, f) - 3.5), -83.5], f \in RFIBANDS \end{cases}$ For all other subcarriers, $CDPSD_{us}(f) \leq PSDMASK_{us}(f)$. For any valid setting of CDPSD _{us} , the aggregate upstream transmit power shall not exceed the MAXNOMATP _{us} .
MEDLEY reference PSD mask (MREFMASK)	$MREFMASK_{ds}(f) = \begin{cases} \min(PSDMASK_{ds}(f), MAXMASK_{ds}), f \notin RFIBANDS \\ \min(PSDMASK_{ds}(f), MAXMASK_{ds}, -80), f \in RFIBANDS \end{cases}$ $MREFMASK_{us}(f) = \begin{cases} \min(PSDMASK_{us}(f), MAXMASK_{us}, UPBOMASK(kl_o, f)), f \notin RFIBANDS \\ \min(PSDMASK_{us}(f), MAXMASK_{us}, UPBOMASK(kl_o, f) - 80), f \in RFIBANDS \end{cases}$
MEDLEY reference PSD (MREFPSD)	$MREFPSD_{ds}(f) \leq (MREFMASK_{ds}(f) - 3.5 \text{ dB})$ for all subcarriers of the downstream passband (including downstream RFI bands allowed to carry data) and $MREFPSD_{ds}(f) \leq MREFMASK_{ds}(f)$ for all other frequencies. For any valid setting of MREFPSD _{ds} , the aggregate downstream transmit power shall not exceed the MAXNOMATP _{ds} . $MREFPSD_{us}(f) \leq (MREFMASK_{us}(f) - 3.5 \text{ dB})$ for all subcarriers of the upstream passband (including upstream RFI bands allowed to carry data) and $MREFPSD_{us}(f) \leq MREFMASK_{us}(f)$ for all other frequencies. For any valid setting of MREFPSD _{us} , the aggregate upstream transmit power shall not exceed the MAXNOMATP _{us} .
NOTE – RFI bands are not incorporated in the transmit PSD mask.	

NOTE – Table 7-4 specifies PSDs and PSD masks at every frequency (i.e., in both the passband and the stopbands). To avoid communication of redundant information, the corresponding messages during initialization do not describe the PSDs in the full frequency range, nor do they describe the RFI bands.

The process of determining the PSDs and PSD masks of the VTU during initialization and showtime is summarized in Table 7-5.

Table 7-5 – Summary: Determination and use of PSDs and PSD masks

Parameter	When determined	When communicated between VTUs (Note)	When used
Limit PSD mask (LIMITMASK)	Configuration of MIB before start of initialization	Not communicated	By VTU-O, before start of initialization, to calculate downstream and upstream transmit PSD masks
MIB PSD mask (MIBMASK)	Configuration of MIB before start of initialization	Not communicated	By VTU-O, before start of initialization, to calculate downstream and upstream transmit PSD masks
RFI bands (RFIBANDS)	Configuration of MIB before start of initialization	RFIBANDS is sent by VTU-O to VTU-R during ITU-T G.994.1 handshake phase	Notches are applied in designated bands in applicable transmission direction(s) from the start of initialization and thereafter
Initial PSD ceiling (CDMAXMASK)	By the VTU-O before start of initialization, by the VTU-R at the beginning of channel discovery phase	Initial value of downstream PSD ceiling is sent by VTU-O to VTU-R in O-SIGNATURE; initial value of upstream PSD ceiling is sent by VTU-R to VTU-O in R-MSG1	For all signals during the channel discovery phase (initial downstream ceiling avoids saturation of the VTU-R over short loops)
Transmit PSD mask (PSDMASK)	By the VTU-O before start of initialization	PSDMASKds and PSDMASKus are sent by VTU-O to VTU-R in O-SIGNATURE	For all signals during channel discovery phase
UPBO PSD mask (UPBOMASK)	By the VTU-R at the beginning of the channel discovery phase	Not communicated	For all signals during channel discovery phase and thereafter
Channel discovery PSD (CDPSD)	At the beginning of channel discovery phase; VTU-O determines CDPSDds, VTU-R determines CDPSDus	CDPSDds is sent by VTU-O to VTU-R in O-SIGNATURE; CDPSDus is sent by VTU-R to VTU-O in R-MSG 1	For all signals during channel discovery phase
PSD ceiling (MAXMASK)	At the end of channel discovery phase; VTU-O determines MAXMASKds, VTU-R determines MAXMASKus	MAXMASKus is sent by VTU-O to VTU-R in O-UPDATE. MAXMASKds is sent by VTU-R to VTU-O in R-UPDATE	From the beginning of training phase and thereafter

Table 7-5 – Summary: Determination and use of PSDs and PSD masks

Parameter	When determined	When communicated between VTUs (Note)	When used
MEDLEY reference PSD mask (MREFMASK)	At the end of channel discovery phase; VTU-O determines MREFMASKds, VTU-R determines MREFMASKus	Not communicated	From the beginning of training phase and thereafter during initialization and showtime
MEDLEY reference PSD (MREFPSD)	At the end of channel discovery phase; VTU-O determines MREFPSDds, VTU-R determines MREFPSDus	MREFPSDds is sent by VTU-O to VTU-R in O-PRM; MREFPSDus is sent by VTU-R to VTU-O in R-PRM	During the training and channel analysis and exchange phases
Showtime PSD	At the end of the channel analysis and exchange phase	Determined by the MREFPSD and the gain values (g_i) communicated during the channel analysis and exchange phase (O-PMD and R-PMD messages). Shall not exceed MREFMASK.	During showtime

NOTE – Only the minimum set of relevant parameters characterizing PSDs and PSD masks is communicated during initialization. The communication protocols and formats are described in clause 12.

7.3 Termination impedance

A termination impedance of $R_V = 100$ Ohm, purely resistive, at the U interface, shall be used over the entire VDSL2 frequency band for both VTUs. In particular, $R_V = 100$ Ohm shall be used as a termination for the transmit PSD and power definition and verification.

NOTE – This termination impedance approximates the insertion-point impedance of the VDSL2 test loop and harmonizes VDSL2 and ADSL2.

7.4 Longitudinal conversion loss

Longitudinal conversion loss (LCL) is a measure of the degree of unwanted transversal signal produced at the input of the VDSL2 transceiver due to the presence of a longitudinal signal on the connecting leads. The longitudinal voltage (V_{cm}) to transversal voltage (V_{diff}) ratio shall be measured in accordance with [ITU-T G.117] and [ITU-T O.9]. During the measurement, the transceiver under test shall be powered, and in the L3 state (see clause 12.1).

$$LCL = 20 \log_{10} \left| \frac{V_{cm}}{V_{diff}} \right| \text{dB}$$

The LCL of the VDSL2 transceiver shall be greater than or equal to 38 dB in the frequency band up to 12 MHz.

In the frequency band above 12 MHz, the LCL of the VDSL2 transceiver for frequency f shall be greater than or equal to $38 \text{ dB} - 20 \log_{10}(f_{[\text{MHz}]} / 12)$ for $12 \text{ MHz} < f < F_{max}$, where F_{max} is the higher of the highest passband frequency in the upstream and downstream directions for the Limit PSD masks selected.

The termination impedance of the transceiver for LCL measurement shall be $R_V = 100 \text{ Ohm}$. The LCL shall be measured at the U-O2 (U-R2) interface. LCL shall be measured in the frequency band between the lower of the lowest passband frequency in the upstream and downstream directions and F_{max} .

NOTE 1 – The equipment balance should be better than the anticipated access network balance in order to minimize the unwanted emissions and susceptibility to external RFI.

NOTE 2 – VDSL2 performance may benefit from even higher balance. Where subject to repetitive electrical impulse noise, systems operating at frequencies where the cable balance may be 50 dB could be limited in capacity by a 38 dB balance.

NOTE 3 – The required LCL may be increased in a future revision of this Recommendation.

8 Transport protocol specific transmission convergence (TPS-TC) function

The TPS-TC sublayer resides between the γ reference point and the α/β reference point as presented in the VDSL2 and VTU functional model in Figure 5-1. This functional model defines the TPS-TC sublayer as containing one or more TPS-TCs providing transport of user data utilizing different transport protocols, a management TPS-TC (MPS-TC) providing eoc transport over the VDSL2 link, an NTR-TC providing transport of the network timing reference, and a ToD-TC providing transport of the time-of-day.

Functionality, parameters, and application interface (γ interface) characteristics of the user data TPS-TC are specified in clause 8.1. Functionality, parameters, and application interface (γ interface) characteristics of the MPS-TC are specified in clause 8.2. Functionality, parameters, and application interface (γ interface) characteristics of the NTR-TC are specified in clause 8.3. Functionality, parameters, and application interface (γ interface) characteristics of the ToD-TC are specified in clause 8.4.

The mandatory TPS-TC sublayer configuration shall include the MPS-TC, the NTR-TC, and at least one user data TPS-TC. Support of a second user data TPS-TC or the ToD-TC is optional. Each TPS-TC operates over a separate bearer channel, where the PMS-TC may allocate these bearer channels to a single or to separate latency paths.

8.1 The user data TPS-TC

8.1.1 User data TPS-TC types

There are three types of user data TPS-TCs defined in this Recommendation:

- Type 1: STM transport (STM-TC);
- Type 2: ATM transport (ATM-TC); and
- Type 3: Ethernet and generic packet transport (PTM-TC).

Each of these three types is defined as an application option. The VTU-O selects the user data TPS-TC type for each bearer channel, both upstream and downstream, based on the type of higher layer data it chooses to support on that bearer channel. The enabled user data TPS-TC type for each of the bearer channels is indicated during initialization.

Functionality, parameters, and application interface (γ interface) characteristics of the user data TPS-TCs supporting STM transport (STM-TC), ATM transport (ATM-TC), and Ethernet and generic packet transport (PTM-TC) are specified in L.1, L.2 and L.3, respectively.

The transmit signals of the TPS-TC are submitted to the α/β interface. Signals passing via the α/β interface in both directions have an application-independent (transport protocol independent) format, as specified in clause 8.1.2. The particular bit rates for each of the multiplexed TPS-TCs at the α/β reference point are determined during system configuration.

8.1.2 α/β interface specification

The α and β reference points define corresponding interfaces between the TPS-TC and PMS-TC at the VTU-O and VTU-R sides, respectively. Both interfaces are logical, application independent, and identical. The interfaces comprise the following flows of hypothetical signals between the TPS-TC and the PMS-TC sublayers:

- Data flow;
- Synchronization flow; and
- Control flow.

The various signals are summarized in Table 8-1.

Table 8-1 – User data TPS-TC: α/β interface data and synchronization flows signal summary

Signal	Description	Direction
Data signals		
Tx	Transmit data	TPS-TC → PMS-TC
Rx	Receive data	TPS-TC ← PMS-TC
Synchronization signals		
Osync_t	Transmit octet timing	TPS-TC ← PMS-TC
Osync_r	Receive octet timing	
Control signals		
Syncflag	Reconfiguration flag	TPS-TC ← PMS-TC

8.1.2.1 Data flow

The data flow comprises two generic octet-oriented streams with the rates defined by the physical net data rate capabilities:

- Transmit data stream: Tx;
- Receive data stream: Rx.

The data flow signal description is presented in Table 8-1.

The Tx and Rx data rate values are set during initialization as described in clause 12.3.5.2.1. The bit order in the data flow shall provide that the MSB of the TPS-TC data is sent to the PMS-TC first. This bit convention is clarified for the ATM-TC in Figure L.8 and for the PTM-TC in clause N.3.4 of [ITU-T G.992.3], and for the MPS-TC in clauses 8.2.3 and 9.5.2.2.

8.1.2.2 Synchronization flow

This flow provides synchronization between the TPS-TC sublayer and the PMS-TC sublayer. The synchronization flow comprises the two synchronization signals presented in Table 8-1:

- Transmit and receive data flow octet-synchronization (Osync_t, Osync_r).

All synchronization signals are asserted by the PMS-TC and directed towards the TPS-TC. The signals Osync_t and Osync_r determine the octet boundaries and the rates of the corresponding Tx and Rx data signals. In the case that the clock rate provided by the PMS-TC changes due to a reconfiguration, this change shall occur at an octet boundary, and shall be determined by the corresponding change in the Osync signal. The detailed description of the reconfiguration for specific TPS-TCs is in Annex L.

8.1.2.3 Control flow

This flow provides a time marker (Syncflag, as specified in Table 8-1) for changes of the TPS-TC parameters (see clauses L.1.11.1, L.2.11.1, and L.3.11.1). The Syncflag is asserted by the PMS-TC and indicates a specific time when the TPS-TC shall start operating with modified parameters.

8.1.3 Control parameters

The configuration of the TPS-TC functions is controlled by a set of control parameters. Some of the control parameters are defined in Table 8-2. The remaining control parameters are dependent on the TPS-TC type and are defined in Annex L.

Table 8-2 – TPS-TC parameters

Parameter	Definition
N_{BC}	The number of enabled transmit TPS-TC functions and the number of enabled bearer channels. The TPS-TC functions and bearer channels are labelled #0, #1. N_{BC} is the number of non-zero values in the $\{type_0, type_1\}$ set. The value of N_{BC} may be different for the VTU-O and VTU-R transmitters.
$type_n$	The TPS-TC type mapped to bearer channel # n ($n = 0$ to 1). The type of the specific TPS-TC shall be set to a value described in Annex L ($type_n = 1$ (STM), $type_n = 2$ (ATM), or $type_n = 3$ (PTM)). The $type_n$ value of zero shall be used to disable TPS-TC function # n and bearer channel # n .

The values of all control parameters listed in Table 8-2 shall be configured during the channel analysis and exchange phase of initialization (see clause 12.3.5), using the O-TPS SOC message (see Tables 12-6 and 12-51).

8.1.3.1 Valid configurations

A VTU may support two simultaneous TPS-TC functions in each direction. The control parameter N_{BC} shall be in the 1 to 2 range.

The valid values of the control parameter $type_n$ shall be those contained within Annex L or the value zero. All other values are reserved for use by ITU-T. If the $type_n$ parameter is non-zero for upstream and downstream, then it shall have the same value for upstream and downstream.

A VTU shall support mapping of all supported TPS-TC types to all supported bearer channels, except that PTM on one bearer channel and ATM on the other bearer channel shall not be enabled simultaneously. The valid labelling of supported bearer channels shall start from 0 and increase by one. Thus, there are only two cases:

- Single bearer channel mode: support of at least one TPS-TC function (of a type defined in Annex L) and one bearer channel. For this mode, bearer channel #0 shall be enabled.
- Dual bearer channel mode: support of at least two TPS-TC functions (of a type defined in Annex L) and two bearer channels. For this mode, bearer channels #0 and #1 shall be enabled.

8.1.3.2 Mandatory configurations

A VTU shall support single bearer channel mode in the downstream direction.

A VTU shall support single bearer channel mode in the upstream direction.

8.2 Management TPS-TC (MPS-TC)

The MPS-TC is intended to facilitate transport of eoc data between the VDSL2 management entities (VME-O, VME-R) at opposite ends of the VDSL2 link (see Figure 5-1).

8.2.1 Functional model

The MPS-TC shall provide fully-transparent eoc data transfer between the γ_{m-O} and γ_{m-R} interfaces (in the absence of non-correctable errors in the lower sublayers), and packet integrity of the transported eoc messages (commands and responses). In the transmit direction, the MPS-TC gets the eoc message from the VME over the application interface (γ_m interface), encapsulates it using the HDLC frame format, and submits it to the α/β interface to be transported via the VDSL2 link using the PMS-TC overhead messaging channel specified in clause 9.5.2. In the receive direction, the MPS-TC delineates the HDLC frames, runs the FCS check, and extracts the encapsulated eoc message from the correctly received HDLC frames. The received eoc messages are submitted to the VME over the γ_m interface. All incorrectly received HDLC frames shall be discarded.

NOTE – If the PMS-TC operates in dual latency mode (see clause 9.1), the encapsulated eoc messages are carried in the latency path which is determined by the control variable in the MSGLP field. This value is set during initialization in accordance with the type of OH frame being used, as specified in clauses 9.5.2.2 and 12.3.5.2.1.3.

8.2.2 Interface description

8.2.2.1 γ interface

The γ_{m-O} and γ_{m-R} reference points define interfaces between the VME and the MPS-TC at the VTU-O and VTU-R respectively, as shown in Figure 5-1. Both interfaces are identical, functional, and are defined by three signal flows between the VME and the MPS-TC:

- Data flow;
- Synchronization flow; and
- Control flow.

The various signals are summarized in Table 8-3.

Table 8-3 – MPS-TC: γ_m interface data, synchronization and control flows signal summary

Flow	Signal	Description	Direction
Transmit signals			
Data	<i>Tx_eoc</i>	Transmit data	VME → MPS-TC
Sync	<i>Tx_Avbl</i>	Asserted by the VME if the message is available for transmission	VME → MPS-TC
Sync	<i>Tx_Clk</i>	Transmit clock	VME → MPS-TC
Sync	<i>Tx_SoM</i>	Start of the transmit message	VME → MPS-TC
Sync	<i>Tx_EoM</i>	End of the transmit message	VME → MPS-TC
Control	<i>Tx_stop</i>	Interruption of the transmission of the message	VME → MPS-TC
Control	<i>Tx_RF</i>	Response flag	VME → MPS-TC
Control	<i>Tx_PrF</i>	Priority flag	VME → MPS-TC
Control	<i>Sent</i>	Sent flag	VME ← MPS-TC
Receive signals			
Data	<i>Rx_eoc</i>	Receive data	VME ← MPS-TC
Sync	<i>Rx_Enbl</i>	Asserted by the MPS-TC; indicates that the VME may pull the message from the MPS-TC	VME ← MPS-TC
Sync	<i>Rx_Clk</i>	Receive clock	VME → MPS-TC

Table 8-3 – MPS-TC: γ_m interface data, synchronization and control flows signal summary

Flow	Signal	Description	Direction
Transmit signals			
Sync	<i>Rx_SoM</i>	Start of the receive message	VME ← MPS-TC
Sync	<i>Rx_EoM</i>	End of the receive message	VME ← MPS-TC
Control	<i>Rx_RF</i>	Response flag	VME ← MPS-TC
Control	<i>Rx_PrF</i>	Priority flag	VME ← MPS-TC

8.2.2.1.1 Data flow

The data flow shall consist of two contra-directional octet-based streams of messages with variable length: transmit messages (*Tx_eoc*) and receive messages (*Rx_eoc*). Bits within each octet are labelled a_1 through a_8 , with a_1 being the LSB and a_8 being the MSB. Octets are labelled in numeric order. The VME shall send the eoc message to the MPS-TC with bit a_1 of the first octet sent first. The data flow signal description is presented in Table 8-3.

8.2.2.1.2 Synchronization flow

This flow provides synchronization between the VME and the MPS-TC and contains the necessary timing to provide integrity of the transported message. The synchronization flow shall consist of the following signals presented in Table 8-3:

- Transmit and receive timing signals (*Tx_Clk*, *Rx_Clk*): both asserted by the VME;
- Start of message signals (*Tx_SoM*, *Rx_SoM*): asserted by the VME and by the MPS-TC, respectively, to mark the beginning of the transported message in the corresponding direction of transmission;
- End of message signals (*Tx_EoM*, *Rx_EoM*): asserted by the VME and by the MPS-TC, respectively, to mark the end of the transported message in the corresponding direction of transmission;
- Transmit packet available signals (*Tx_Avbl*): asserted by the VME to indicate that the message is ready for transmission; and
- Enable receive signal (*Rx_Enbl*): asserted by the MPS-TC to indicate that the data packet may be pulled from the MPS-TC by the VME.

8.2.2.1.3 Control flow

This flow provides priority management of the sent messages, and consists of the following signals presented in Table 8-3:

- Stop transmission (*Tx_Stop*): asserted by the VME to indicate that the MPS-TC shall stop the transmission of the current message (to release the channel for a message with higher priority);
- Response flag (*Tx_RF*, *Rx_RF*): asserted by the VME and MPS-TC, respectively, to indicate that the eoc message contains a response;
- Priority flag (*Tx_PrF*, *Rx_PrF*): asserted by the VME and MPS-TC, respectively, to indicate the priority level of the command carried by the eoc message; and
- Sent flag (*Sent*): asserted by the MPS-TC to mark the time the last octet of the HDLC frame was sent over the α/β interface.

8.2.2.2 α/β interface

The α and β reference points define interfaces between the MPS-TC and PMS-TC at the VTU-O and VTU-R, respectively. Both interfaces are functional, and shall comply with the definition for user TPS-TC as specified in clause 8.1.2. The MPS-TC shall ignore the Syncflag signal; the parameters of the MPS-TC are not subject to on-line reconfiguration.

8.2.3 Encapsulation format

The MPS-TC shall encapsulate messages for transmission using an HDLC-based frame format as shown in Table 8-4.

Table 8-4 – HDLC frame structure

Octet #	MSB	LSB
	7E ₁₆ – Opening flag	
1	Address field	
2	Control field	
3	Message octet #1	
...	
$P + 2$	Message octet # P	
$P + 3$	FCS high octet	
$P + 4$	FCS low octet	
	7E ₁₆ – Closing flag	

The MSB of octets of the encapsulated message shall be the MSB of the corresponding octet in the HDLC frame. The first octet of the eoc message incoming from the γ interface shall be transmitted first and the MSB of each octet shall be transmitted first.

8.2.4 Communication protocol

8.2.4.1 Transmitter

The transmitter shall encapsulate eoc messages prior to transmission using the HDLC frame structure described in clause 8.2.3. The frame check sequence (FCS), the octet transparency mechanism, and HDLC inter-frame time filling shall be as described in [ITU-T G.997.1]. Opening and closing flags of two adjacent HDLC frames may be shared: the closing flag of one frame can serve as an opening flag for the subsequent frame.

If a Tx_Stop signal is set, the transmitter shall stop the transmission of the current message using the abort sequence described in [ITU-T G.997.1] (i.e., by a control escape octet followed by a flag), and get ready to receive a new message from the VME to be transmitted. If the transmission of the message is already completed when a Tx_Stop signal is set, the MPS-TC shall ignore it.

The transmitter shall set the two LSBs of the Address field in accordance with the priority level of the command sent, indicated by the Tx_PrF signal, as follows:

- 00 – High priority;
- 01 – Normal priority;
- 10 – Low priority;
- 11 – Near High priority.

All other bits of the Address field shall be set to ZERO.

The transmitter shall set the second LSB of the Control field with a command code (0) or a response code (1), in accordance with the signal Tx_RF . All other bits of the Control field shall be set to ZERO.

Upon the completion of the transmission of the HDLC frame, the transmitter shall set the *Sent* signal, indicating to the VME the start of the time-out timer (see Table 11-1).

8.2.4.2 Receiver

The receiver shall search for octet boundaries of HDLC frames. All incorrectly received frames, including invalid frames described in [ITU-T G.997.1] and frames with an invalid FCS, shall be discarded. Frames with an Address field or Control field not meeting the HDLC frame structure described in clauses 8.2.3 and 8.2.4.1 shall be discarded.

The MPS-TC shall extract the encapsulated eoc commands/responses from the correctly received HDLC frames, and send them to the VME via the γ_m interface.

The receiver shall use the second LSB of the Control field of the received HDLC frame to distinguish between commands and responses and shall set the Response flag Rx_RF accordingly. The receiver shall use the last two LSBs of the Address field to identify the priority of the eoc command carried by the received HDLC frame and shall set the Priority flag Rx_PrF accordingly. Both Rx_RF and Rx_PrF shall be asserted upon the arrival of a valid HDLC header, which includes an Opening Flag, Address field and Control field (see Table 8-4), before the FCS verification of the received HDLC frame, to indicate the arrival time of the eoc message. After the FCS has been verified, the receiver shall set the Rx_Enbl signal to indicate that the correctly-received packet is ready.

NOTE – The VME uses the received Priority flag of the response messages to determine their arrival times and decide whether the response eoc message meets the time-out. Use by the VME of the received Priority flag of the command messages is currently undefined.

8.3 Network timing reference TPS-TC (NTR-TC)

Transport of an 8 kHz network timing reference (NTR) from the VTU-O to the VTU-R shall be supported in order to support isochronous services that require the same exact timing reference at both sides of the VDSL2 line to operate the higher layers of the protocol stack. The VTU-O shall indicate NTR transport during initialization (see clause 12.3.5.2.1.1).

8.3.1 Interfaces

The γ_{m-O} and γ_{m-R} reference points define interfaces between the NTR source and the NTR-TC at the VTU-O and between the NTR-TC and the NTR receiver at the VTU-R, respectively, as shown in Figure 5-1. Both interfaces are identical, functional, and are defined by the signals specified in Table 8-5.

Table 8-5 – NTR-TC: γ interface signal summary

Flow	Signal	Description	Direction
Transmit signals (VTU-O)			
NTR	Tx_NTR	Transmit NTR signal	NTR source → NTR-TC
Receive signals (VTU-R)			
NTR	Rx_NTR	Receive NTR signal	NTR receiver ← NTR-TC

The α and β reference points define interfaces between the NTR-TC and PMS-TC at the VTU-O and VTU-R, respectively. Both interfaces are functional, and shall comply with the definition in clause 8.1.2 with the additional condition that NTR data is transmitted only in the direction from the VTU-O to the VTU-R. The NTR-TC shall ignore the Syncflag signal; the parameters of NTR-TC are not subject to on-line reconfiguration.

8.3.2 Functionality

NTR transport is facilitated by the NTR-TC. At the VTU-O the NTR-TC encodes the incoming NTR signal transitions into the NTR byte to be transported over the VDSL2 link in the NTR field of the OH frame. At the VTU-R the NTR-TC extracts the NTR byte from the OH frame and reconstructs the NTR signal.

The NTR-TC at the VTU-O shall generate the NTR bytes in the following way. The VTU-O shall derive a local 8 kHz timing reference (LTR) by dividing its sampling clock by the appropriate number. Further, the VTU-O shall estimate the change in phase offset between the NTR and the LTR from the previous OH frame to the present OH frame (see clause 9.5.2). The change in phase offset shall be estimated at the beginning of the OH frame. The estimated value shall be expressed in cycles of the sampling clock running at frequency $8192 \times \Delta f$, and shall be mapped to the NTR byte as a 2-complement number.

The bits of the NTR byte, denoted by ntr_7 to ntr_0 , represent a signed integer in the range between -128 to $+127$. A positive value of the change in phase offset (ntr_7 is set to ZERO) indicates that the LTR has a higher frequency than the NTR; a negative value of the change in phase offset (ntr_7 is ONE) indicates that the LTR has a lower frequency than the NTR. The ntr bits shall all be set to ZERO if the VTU-O locks its transmit PMD clock to the NTR frequency.

The NTR byte is transported in the NTR field of the OH frame. The mapping of the ntr bits to the NTR field of the OH frame is specified in clause 9.5.2.2.

The NTR-TC at the VTU-R shall reconstruct the 8 kHz NTR from the received values of the NTR byte using the encoded changes in the phase offset.

NOTE – In VDSL2, the sampling clock is proportional to the subcarrier spacing Δf . Therefore, the LTR, being proportional to the sampling clock, will have the same ± 50 ppm frequency variation as Δf (see clause 10.4.2). The NTR has a maximum variation of ± 32 ppm, thus the maximum difference in frequency between the NTR and the LTR will not exceed 82 ppm. This would result in a maximum time offset of $82 \times 10^{-6} \times PER_p$, where PER_p is the duration of the OH frame as defined in clause 9.5.4. This corresponds to $(82 \times 10^{-6} \times PER_p) \times 8192 \times \Delta f$ sampling cycles, which, for a subcarrier spacing of 4.3125 kHz, is equal to $2896 \times PER_p$ sampling cycles. With the maximum value of PER_p , which is less than 20 ms (see Table 9-8), the value of the offset to be transmitted will not exceed ± 58 . Therefore, the one-byte information field reserved for NTR is sufficient.

8.4 Time-of-day TPS-TC (ToD-TC)

Transport of time-of-day (ToD) from the VTU-O to the VTU-R should be supported in order to support services that require accurate ToD at both sides of the VDSL2 line to operate the higher layers of the protocol stack. The VTU-O shall indicate ToD transport during initialization (see clause 12.3.5.2.1.1).

NOTE 1 – Exchange of network time management information from VTU-R to VTU-O related to the quality of the ToD frequency and/or time recovery at the VTU-R is for further study.

NOTE 2 – Exchange of relevant clock information from AN to CPE to support the ToD interface output from CPE is for further study. For PTP, this information includes source traceability, number of hops, and leap seconds.

NOTE 3 – The γ -O to γ -R ToD accuracy requirements are for further study, but expected to be in the order of 100/200 ns.

8.4.1 Time-of-day distribution operational overview

Figure 8-1 shows the system reference model identifying the key elements in support of time-of-day transport across a VDSL2 link. The VTU-O receives a time-of-day signal from the master clock across the γ -O interface and the VTU-R outputs a time-of-day signal across the γ -R interface to slave clock external to the VTU-R that is synchronous in frequency, phase and time to the master clock. A

master clock source external to the VTU-O provides a time-of-day signal to the VTU-O across the γ -interface. The details of the time-of-day signal are for further study; however, the components include a time-of-day value (ToD_{mc_value}) to a corresponding clock edge (ToD_{mc_edge}) that is synchronous to the master clock's internal driving frequency. The ToD_{mc_edge} shall provide at least one edge per second. A component of the driving frequency (f_{mc}) shall be available to the VTU-O and shall be at least 8 kHz and shall be frequency and phase synchronized with the ToD_{mc_edge} to facilitate time-of-day transport processing in the VTU-O. Similarly, the time-of-day signal at the VTU-R is assumed to include a time-of-day value (ToD_{sc_value}) together with corresponding time edge marker (ToD_{sc_edge}) that is synchronous to the driving frequency of the master clock. A component of the driving frequency (f_{sc}) may be available from the VTU-R to facilitate time-of-day transport processing.

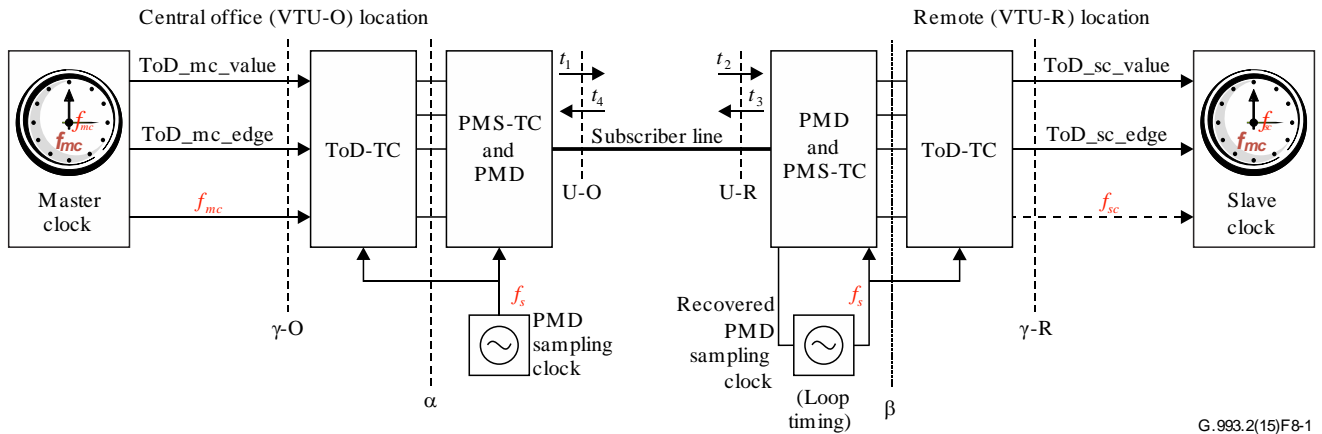

G.993.2(15)F8-1

Figure 8-1 – End-to-end system reference model for time-of-day transport in VDSL2

The VDSL2 PMD operates with a sampling clock for transmission of the DMT symbols on the subscriber line. The VTU-R's PMD sampling clock and the VTU-O's PMD sampling clock are assumed to be frequency locked, typically through loop timing in the VTU-R. For both the upstream and downstream transmit signals, the reference sample is defined as the first time-domain representation sample (see Figure 8-2 and Figure 8-3) of the first symbol in a superframe period (64.25 ms on the PMD sampling clock timebase if the CE length corresponds to $m = 5$, see clause 10.4.4).

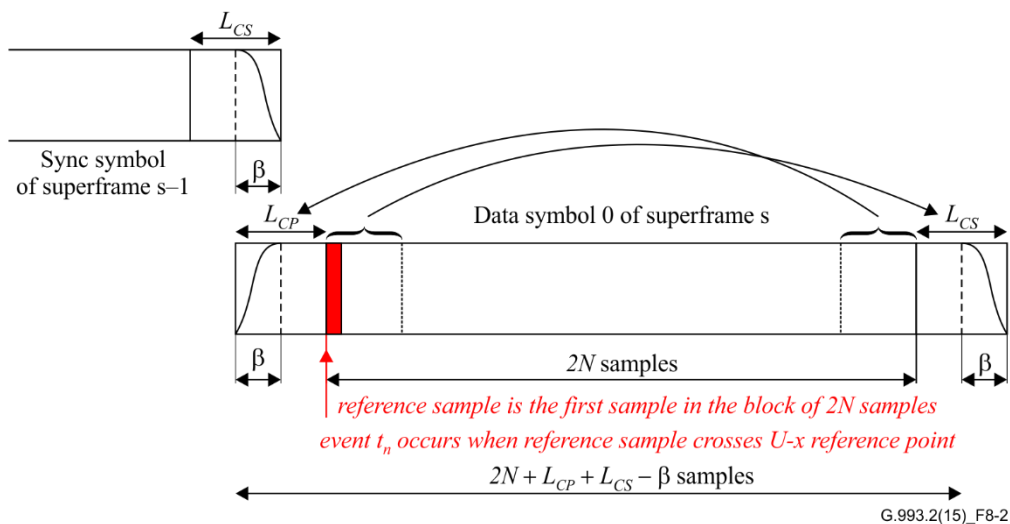

G.993.2(15)_F8-2

Figure 8-2 – Cyclic extension, windowing and overlap of DMT symbols

The VDSL2 PMD in the VTU-O identifies the moment the downstream reference sample crosses the U-O interface (event t_1) and the moment (within one superframe from event t_1) the upstream reference sample crosses the U-O interface (event t_4); at the instant each event occurs, the ToD-TC (time-of-day – transmission convergence) in the VTU-O records the corresponding time values of its local real-time clock (RTC-O) to apply a time stamp to each of the respective events t_1 and t_4 . For each event t_1 , the VTU-O sends the ToD phase difference (i.e., the corresponding t_1 time stamp MOD 125 000 ns, represented in units of 2 ns) and the t_1 event number (i.e., representing the superframe counter value at the t_1 event) to the VTU-R. The VTU-R processes the ToD phase difference values to recover the ToD frequency. At a much slower rate, the VTU-O also sends the t_1 and t_4 time stamps together with a t_1 and t_4 event number to VTU-R for time/phase synchronization of the real time clocks. Similarly, the VDSL2 PMD in the VTU-R identifies the moment the downstream reference sample crosses the U-R interface (event t_2) and the upstream reference sample crosses the U-R interface (event t_3); at the instant each event occurs, the ToD-TC in the VTU-R records the corresponding time of the local slave clock to apply a time stamp to each of the respective events t_2 and t_3 . The ToD-TC in the VTU-R processes the time stamp values of events t_1 , t_2 , t_3 , and t_4 so as to synchronize in phase and time its local real-time clock (RTC-R) to the VTU-O's real-time clock (RTC-O).

NOTE 1 – The time period between consecutive reference samples is fixed and equal to the number of samples in a super-frame. This time period is therefore locked to the VTU's PMD sampling clock. With this relation, the time stamp values are recorded at regularly repeating intervals.

NOTE 2 – The VTU-R sends the values of events t_2 and t_3 to the VTU-O in response to a VTU-O command sending the corresponding t_1 and t_4 event values for phase/time synchronization.

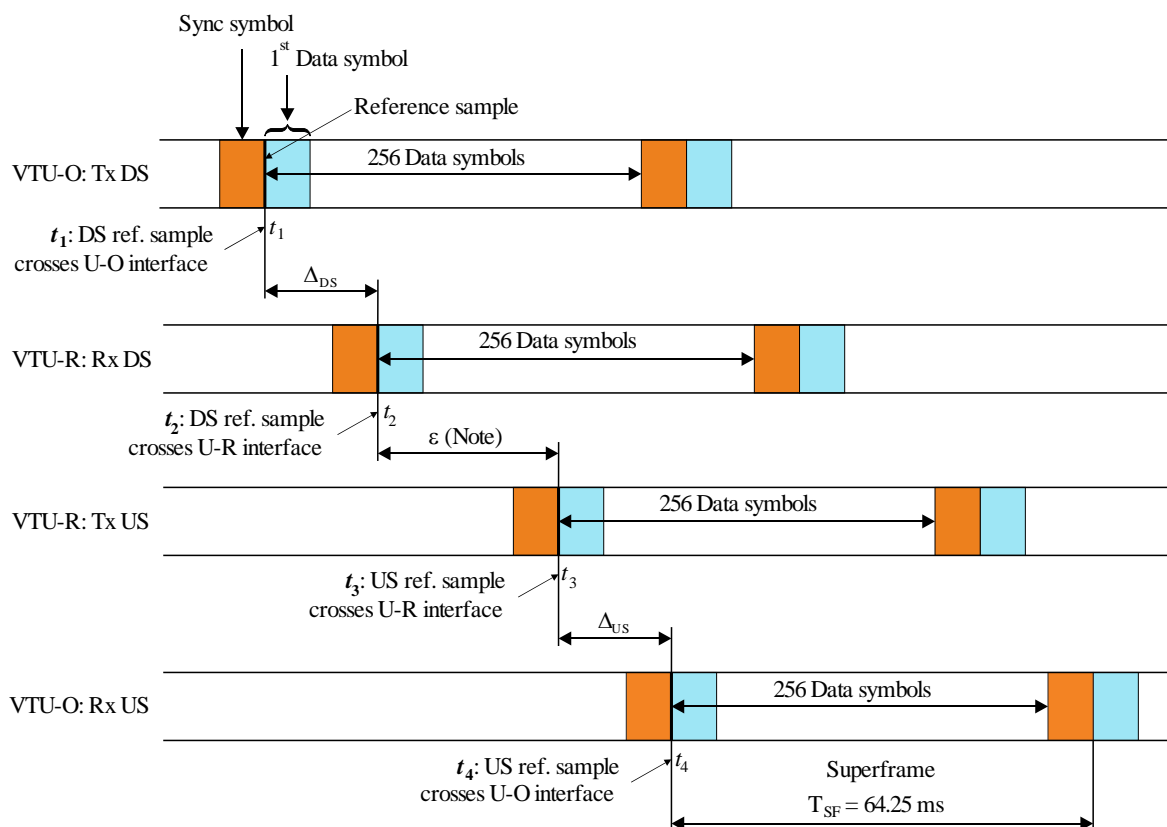

NOTE – ϵ may be a positive or a negative time

G.993.2(15)_F8-3

Figure 8-3 – Reference samples and corresponding time stamp events t_1 , t_2 , t_3 and t_4

The ToD-TC in the VTU-O and that in the VTU-R implement functionality with the objective of synchronizing the RTC-R to the RTC-O in frequency, phase and time. Two methods are defined to achieve this objective:

- Frequency synchronization through locking the PMD sampling clock with the ToD frequency (f_{mc}): the VTU-R achieves frequency synchronization through loop timing and performs phase/time synchronization through the processing of time stamps at reference samples, or
- Frequency synchronization using ToD phase difference values: the VTU-R achieves frequency synchronization through processing of ToD phase difference values (i.e., phase of t_1 event relative to ToD) and performs phase/time synchronization through the processing of time stamps (of events t_1 , t_2 , t_3 , and t_4) at the reference samples.

The frequency synchronization method adopted in the VTU-O is communicated to the VTU-R during initialization (see clause 12.3.5.2.1.2). For each of the above cases, the corresponding functional processing is described.

The block diagram in Figure 8-4 shows a functional model of the required processing in the VTU-O ToD-TC. The ToD-TC receives the time-of-day signals from the master clock and assigns time stamps to reference samples per the Real-time Clock (RTC-O), that is synchronous to the external master clock time base.

In the VTU-O, the ToD-TC implements a Real-time Clock (RTC-O) that is synchronized to the external master clock for the purpose of applying time stamps to the reference samples. The VDSL2 PMD identifies the moment that the reference samples cross the U-O interface; the Reference Sample Timing block generates pulses t_1 and t_4 , for reading the value of the RTC-O clock in recording of the respective time stamps for the downstream and upstream reference samples. The time stamp values, $ToD(t_1)$ and $ToD(t_4)$ together with the reference sample identification (event number) are sent to the VTU-R via the eoc.

In the VTU-R, frequency synchronization of the RTC-R clock to the RTC-O clock in the VTU-O may be performed using any of the two methods mentioned above; the frequency synchronization method is selected by the VTU-O during initialization (see clause 12.3.5.2.1.2). Shown in Figure 8-4 is the method of computing phase difference values for frequency synchronization of the Real-time Clock in the VTU-R (RTC-R) with the RTC-O. Phase difference values may be transported to the VTU-R via dedicated bytes in the OH Frame (see clause 9.5.2.2.1) or via the eoc (see clause 11.3.2.14); the transport method is selected by the VTU-R during initialization (see clause 12.3.5.2.2.1). The time stamp values for ToD phase synchronization (i.e., $ToD(t_1)$ and $ToD(t_4)$) are transported to the VTU-R by dedicated eoc commands (see clause 11.2.3.15).

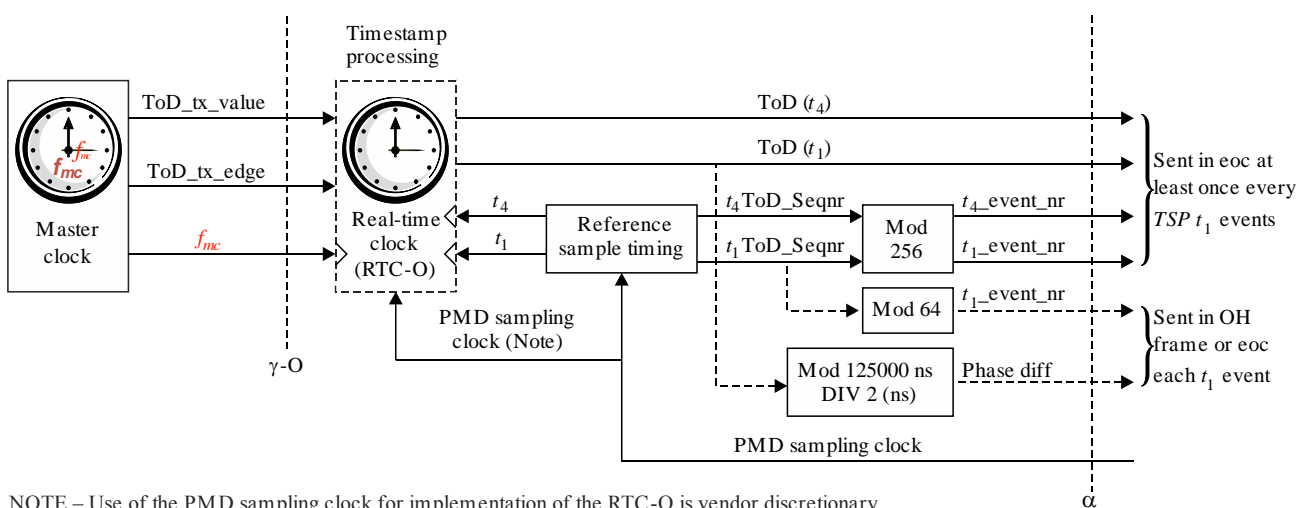

G.993.2(15)F8-4

Figure 8-4 – Functional reference model for ToD-TC in the VTU-O

During initialization, the VTU-O indicates to the VTU-R the configured ToD frequency synchronization method, namely via locking of the VDSL PMD sampling clock to the ToD frequency or via transport of phase difference values. If the VTU-O selects the locking of the PMD sampling clock to the ToD frequency, then the VTU-R achieves ToD frequency synchronization through normal loop timing recovery. If the VTU-O selects the mechanism of passing phase difference values to the VTU-R for ToD frequency synchronization, then the VTU-R selects the mechanism for which the VTU-O is to communicate the phase difference values: i.e., via dedicated fixed octets in the OH frame, or via phase difference messages communicated in the eoc. In either case, time synchronization is provided through processing of the time synchronization messages communicated to the VTU-R by the VTU-O.

In the VTU-R the ToD-TC processes the time stamp values placed on the downstream (event t_2) and upstream (event t_3) reference samples together with those values received from the VTU-O for events t_1 and t_4 to achieve phase/time synchronization of the RTC-R to the RTC-O. The ToD-TC then outputs a time-of-day value (ToD_sc_value) together with a corresponding timing edge marker (ToD_sc_edge) that is synchronous to the driving master clock frequency. The ToD_sc_value and ToD_sc_edge signals (and possibly a slave clock frequency f_{sc}) are transported across the γ -R interface to a device external to the VTU-R. The time stamp values placed on the downstream (event t_2) and upstream (event t_3) reference samples are sent back to the VTU-O (see clause 11.2.3.15). The VTU-O passes information related to these time stamps over the γ -O reference point. The nature and use of this information is for further study.

The time-of-day (phase) synchronization of the RTC-R to the RTC-O, is done in the ToD-TC in the VTU-R. The time stamp processing block reads the value of the local RTC-R as the downstream reference sample crosses the U-R reference point (event t_2) and upstream reference sample crosses the U-R reference point (event t_3), and assigns corresponding time stamp values ToD(t_2) and ToD(t_3). The computation of the offset value (τ) is computed from the reported time stamps using the following equation:

$$\tau = \frac{(ToD(t_2) - ToD(t_1)) - (ToD(t_4) - ToD(t_3))}{2}$$

NOTE 3 – The above computation of the offset value is based on the assumption that the downstream and upstream propagation delays between the U-C and U-R reference points are approximately identical. Any asymmetry in the propagation delay between the U-C and U-R reference points will result in an error in calculation of the offset value whose magnitude is approximately:

$$|error| = \left| \frac{(upstream_propagation_delay) - (downstream_propagation_delay)}{2} \right|$$

8.4.2 Interfaces

The γ_{m-O} and γ_{m-R} reference points define interfaces between the ToD source and the ToD-TC at the VTU-O and between the ToD-TC and the ToD receiver at the VTU-R, respectively, as shown in Figure 5-1. Both interfaces are functionally identical, and are defined in Table 8-6.

Table 8-6 – ToD-TC: γ interface signal summary

Flow	Signal	Description	Direction
Transmit signals (VTU-O)			
ToD	<i>Tx_ToD</i>	Transmit time-of-day signal	ToD source → ToD-TC
Receive signals (VTU-R)			
ToD	<i>Rx_ToD</i>	Receive time-of-day signal	ToD receiver ← ToD-TC

The α and β reference points define interfaces between the ToD-TC and PMS-TC at the VTU-O and VTU-R, respectively. Both interfaces are functional, and shall comply with the definition in clause 8.1.2 with the additional condition that ToD data is transmitted only in the direction from the VTU-O to the VTU-R. The parameters of ToD-TC are not subject to on-line reconfiguration.

8.4.3 Functionality

8.4.3.1 Frequency Synchronization by locking PMD sampling clock with ToD frequency

This clause defines a mechanism for frequency synchronization of the Real-time Clock in the VTU-R (RTC-R) with the Real-time Clock in the VTU-O (RTC-O) by locking the PMD sampling clock with the ToD frequency (f_{mc}). The VTU-R shall achieve frequency synchronization between RTC-R and RTC-O through loop timing.

8.4.3.2 Frequency Synchronization using ToD phase difference values

This clause defines a mechanism for frequency synchronization of the Real-time Clock in the VTU-R (RTC-R) with the Real-time Clock in VTU-O (RTC-O) by processing of the ToD phase difference values between the local super-frame clock (i.e., event t_1) and the ToD (i.e., RTC-O) clock.

The Real-time Clock represents the time-of-day value with a 6 octet seconds field followed by a 4 octet nanosecond field, where the nanosecond field resets to zero every 10^9 ns and the seconds field increments by one.

Figure 8-5 demonstrates the computation of the ToD phase difference value ($\Delta\phi$). The top row in the figure represents the counting of the nanoseconds in the RTC-O. The ToD nanoseconds counter counts the nanoseconds of the RTC-O modulo $125\ \mu\text{s}$ (shown by the 8 kHz waveform in the middle row of the figure). The third row in the figure represents the super-frame (SF) counter of the local clock that is synchronous with the VTU's PMD sampling clock; the rising edge of the SF local clock represents the moment that the downstream reference sample crosses the U-O reference point (i.e., the t_1 event). At the moment the downstream reference sample crosses the U-O reference point, the value of the ToD ns_counter modulo $125\ \mu\text{s}$ is recorded as the 'ToD Phase Difference Value' to be communicated to the VTU-R.

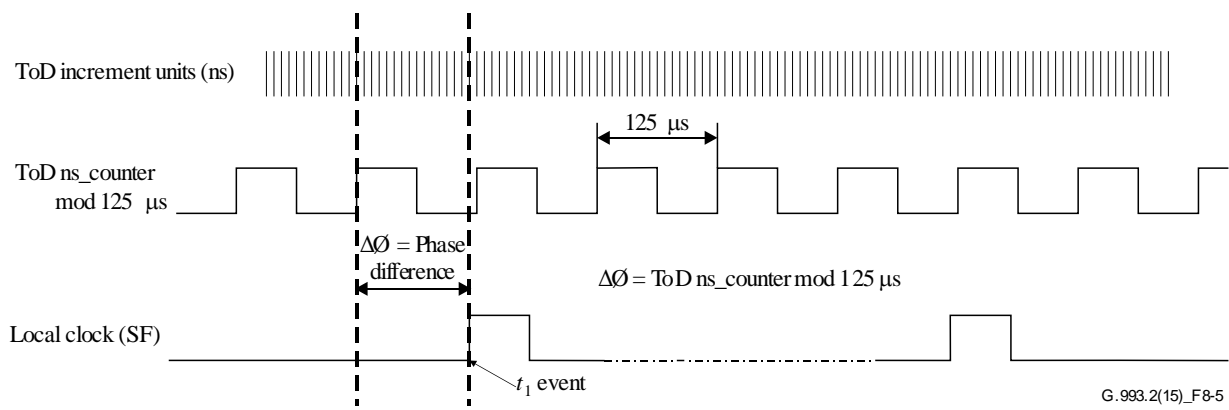

Figure 8-5 – ToD phase difference ($\Delta\phi$) computation

The ToD phase difference value ($\Delta\phi$) is calculated each t_1 event. The ToD phase difference value shall be represented by a 16-bit value, calculated as the ns_counter value of the RTC-O mod 125 000 ns divided by 2, where the resolution of the least significant bit is 2 ns. Each t_1 event shall be counted modulo 64 (i.e., represented by a 6-bit value). The phase difference value (16 bits) and corresponding t_1 event value (6 bits) shall be communicated to the VTU-R either via the OH Frame (see clause 9.5.2.2.1) or via the eoc (see clause 11.2.3.14). During initialization (see clause 12.3.5.2.2.1), the VTU-R shall select the use of either the OH Frame or eoc for communication of ToD phase difference value and corresponding t_1 event value.

8.4.3.3 Time synchronization of real-time clocks

Time-of-day (ToD) transport is facilitated by the ToD-TC. The VTU-O shall maintain a real-time clock at the optical network unit (ONU) (RTC-O) which is synchronized with the ToD signal. The VTU-R shall also maintain a real-time clock at the remote site (RTC-R) with an arbitrary initial time. The RTC-O shall run in a frequency which is an integer multiple of 8 kHz and is at least the PMD sampling frequency, with time adjustment to the master clock at each f_{mc} edge (see Figure 8-1). At the VTU-O, the ToD-TC receives the ToD signal to synchronize RTC-O, generates time stamps using RTC-O, and transports these time stamps to the VTU-R with EOC messages. At the VTU-R, the ToD-TC generates time stamps using RTC-R, extracts the time stamps contained in the eoc messages sent from the VTU-O, estimates the time offset between RTC-O and RTC-R using the time stamps, adjusts RTC-R using the estimated time offset, and controls the output ToD signal.

The time synchronization procedure is defined as follows. A downstream (or upstream) reference sample is defined as the first time-domain sample of specific symbols in the downstream (or upstream) direction during Showtime.

- 1) At the VTU-O, a time stamp is taken by the ToD-TC when the downstream reference sample, being transmitted to the VTU-R, arrives at the U-C reference point (event t_1). The time-of-day corresponding to event t_1 is denoted by $ToD(t_1)$.
- 2) At the VTU-R, a time stamp is taken by the ToD-TC when the same downstream reference sample arrives at the U-R reference point (event t_2). The time-of-day corresponding to event t_2 is denoted by $ToD(t_2)$.
- 3) At the VTU-R, a time stamp is taken by the ToD-TC when the upstream reference sample, being transmitted to the VTU-O, arrives at the U-R reference point (event t_3). The time-of-day corresponding to event t_3 is denoted by $ToD(t_3)$.
- 4) At the VTU-O, a time stamp is taken by the ToD-TC when the same upstream reference sample arrives at the U-O reference point (event t_4). The time-of-day corresponding to event t_4 is denoted by $ToD(t_4)$.

- 5) The time stamp values $ToD(t_1)$ and $ToD(t_4)$ are transmitted from the VTU-O to the VTU-R with eoc messages, the time stamp values $ToD(t_2)$ and $ToD(t_3)$ are transmitted from the VTU-R to the VTU-O with eoc messages (see clause 11.2.3.15).

The VTU-O shall maintain a counter of the transmitted downstream super-frames since the VTU-O entered Showtime. Each time the first symbol in a downstream super-frame (i.e., the symbol modulating downstream data frame 0 per Figure 10-2) is sent, the value of the downstream super-frame counter shall be increased by 1. The downstream reference sample shall be the first time-domain representation sample of the first symbol in a downstream super-frame period (i.e., the first sample after the cyclic prefix of the symbol modulating data frame 0 as defined in Figure 10-14 and Figure 10-2). The index of the downstream reference sample shall be the index of the downstream super-frame it belongs to. The index of the first downstream reference sample (i.e., first t_1 event index) sent in Showtime shall be 0.

The VTU-O shall maintain a counter of the received upstream super-frames since the VTU-R entered Showtime. Each time the first symbol in an upstream super-frame (i.e., the symbol modulating upstream data frame 0 per Figure 10-2) is sent, the value of the upstream super-frame counter shall be increased by 1. The upstream reference sample shall be the first time-domain sample of the first symbol in an upstream super-frame. The index of the upstream reference sample shall be the index of the upstream super-frame it belongs to. The index of the first upstream reference sample (i.e., first t_4 event index) sent in Showtime shall be 0.

The VTU-O initiates a time synchronization procedure. The increment of the t_1 event index between any two consecutive time synchronization procedures shall not exceed the value of the parameter time synchronization period (TSP), which is indicated by the VTU-R during initialization (see clause 12.3.5.2.1.5). The t_1 event index shall be a multiple of 16 super-frames.

After receiving both time stamp values $ToD(t_1)$ and $ToD(t_4)$, the VTU-R shall compute the time offset *Offset* between the Real-time Clocks RTC-O and RTC-R as:

$$Offset = (ToD(t_2) + ToD(t_3) - ToD(t_1) - ToD(t_4)) / 2$$

The RTC-R shall be adjusted with this estimated time offset *Offset* so that it is time synchronized with the RTC-O (i.e., the value of *Offset* for the next time synchronization procedure is expected to be 0).

NOTE – Instead of taking the time stamp $ToD(t_1)$ for event t_1 (i.e., when the reference sample arrives at the U-O reference point), it is easier to implement by taking a time stamp – when the same reference sample arrives at the output of the IDFT of the VTU-O (event t'_1). This time stamp is denoted by $ToD(t'_1)$. The time stamp $ToD(t_1)$ for event t_1 is obtained by adjusting the time stamp $ToD(t'_1)$ for event t'_1 with an estimate of $\Delta t_1 = ToD(t_1) - ToD(t'_1)$. The method of adjustment is vender discretionary. Instead of taking the time stamp $ToD(t_2)$ for event t_2 (i.e., when the reference sample arrives at the U-R reference point), it is easier to implement by taking a time stamp when the same reference sample arrives at the input of the DFT of the VTU-R (event t'_2). This time stamp is denoted by $ToD(t'_2)$. The time stamp $ToD(t_2)$ for event t_2 is obtained by adjusting the time stamp $ToD(t'_2)$ for event t'_2 with an estimate of $\Delta t_2 = ToD(t'_2) - ToD(t_2)$. The method of adjustment is vender discretionary. The time stamps t_3 and t_4 can be obtained in the same way.

9 Physical media specific transmission convergence (PMS-TC) sublayer

The PMS-TC sublayer resides between the α/β interface and δ interface of the VDSL2 transceiver reference model (see Figure 5-1). It provides transmission medium specific TC functions, such as scrambling, framing, forward error correction (FEC), and interleaving.

9.1 PMS-TC functional model

The PMS-TC functional models are presented in Figure 9-1 applicable to single latency mode and

dual latency mode, and Figure 9-2 applicable to single latency with ROC mode. Up to two bearer channels of transmit user data originated by various TPS-TCs, management data originated by the MPS-TC, and NTR data are incoming via the α/β interface in a uniform format, as specified in clause 8.1.2. The incoming user data and the overhead data are multiplexed into one or two latency paths. Each bearer channel is carried over a single latency path (i.e., shall not be split across two latency paths). A Syncbyte is added to each latency path for OH frame alignment.

Three different modes are allowed:

- Single latency mode: support of one latency path. The VTU shall support this mode. For this mode, latency path #0 shall be enabled.
- Dual latency mode: support of two latency paths. The VTU may support this mode. For this mode, latency paths #0 and #1 shall be enabled.
- Single latency with ROC mode: support of a single latency path for data with a second overhead-only latency path. The VTU may support this mode. For this mode, the data shall use latency path#1 and the ROC shall use latency path #0.

NOTE 1 – When transporting two or more applications with different latency and impulse noise protection (INP) requirements and limited higher layer error resilience, a VTU should implement dual latency because, in general, under these conditions dual latency will provide improved performance and/or quality of service.

The multiplexed data in each latency path (including the overhead-only latency path, if present) is scrambled, encoded using Reed-Solomon forward error correction coding, and interleaved. The interleaved buffers of data of both latency paths are multiplexed into a bit stream to be submitted to the PMD sublayer via the δ interface.

All user data bytes incoming via the α/β interface are transmitted MSB first (see clause 8.1.2). All serial processing in the PMS-TC (e.g., scrambling, CRC calculation) shall be performed LSB first, with the MSB incoming from the α/β interface considered as the LSB in the PMS-TC. As a result, the first bit of user data incoming from the α/β interface will be the first bit processed by the PMS-TC and the first bit sent towards the PMD sublayer (see clause 9.1.1).

The management data bytes incoming via the α/β interface are transmitted MSB first (see clause 8.1.2). The LSB of the management data incoming from the α/β interface shall be considered as the LSB in the PMS-TC, and shall be the first bit processed by the PMS-TC and the first bit sent towards the PMD sublayer (see clause 9.1.1).

The indicator bits (IB) and NTR bits shall be sent as described in clause 9.5.2.2.

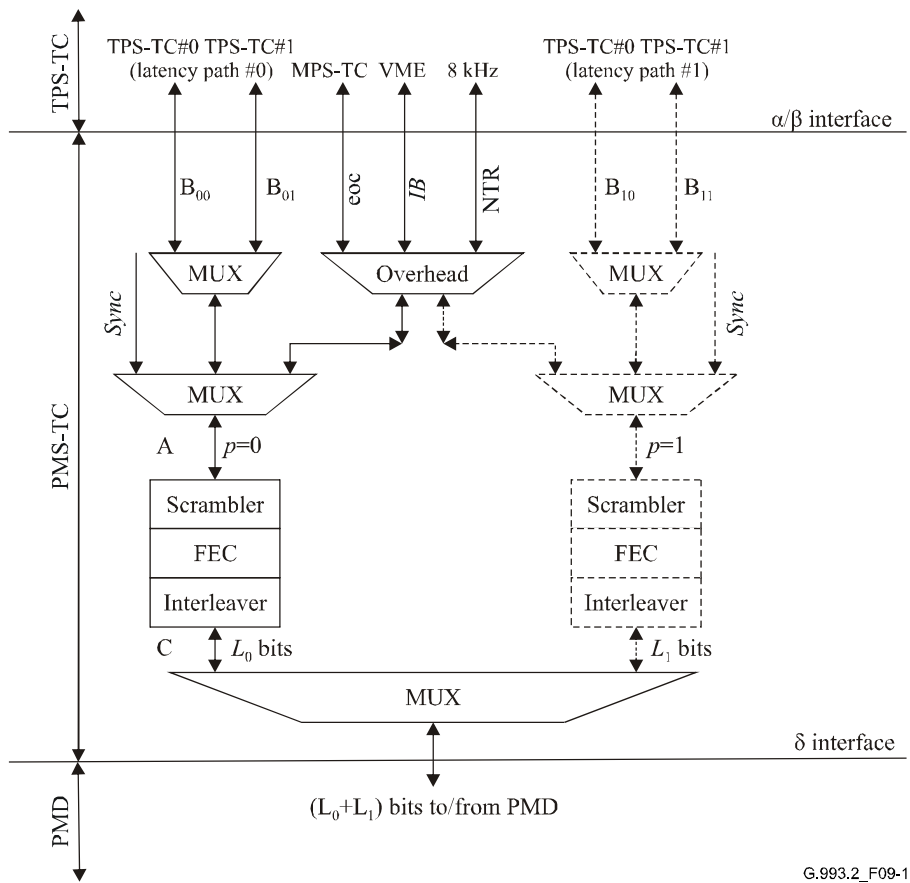
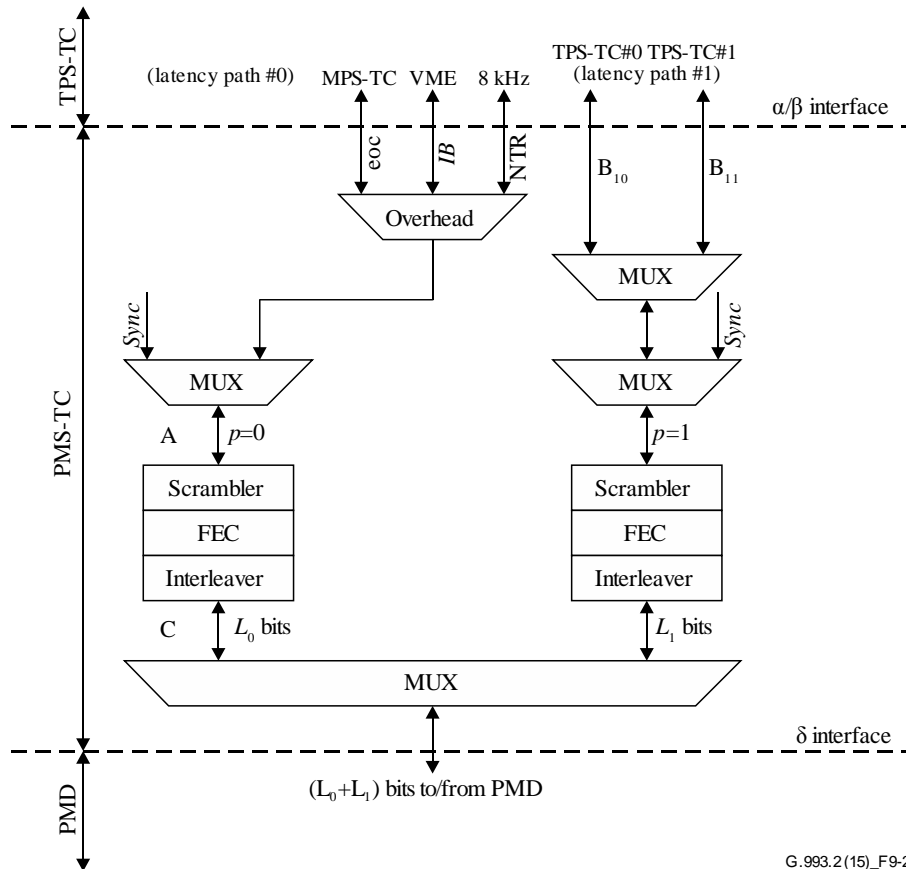

Figure 9-1 – PMS-TC functional model applicable to single latency mode and dual latency mode



G.993.2(15)_F9-2

Figure 9-2 – PMS-TC functional model applicable to single latency with ROC mode

NOTE 2 – The overhead information transmitted on the different latency paths (p_0 , p_1) may be different depending on the type of OH frame used and the values of framing parameters, as specified in clause 9.5.2.

Reference points are defined within the block diagram for purposes of clarity only. The reference points are depicted in Figure 9-1 and listed in Table 9-1.

Table 9-1 – PMS-TC function internal reference points

Reference point	Definition
A: Mux data frame	This reference point is the input of the scrambler of a single latency path. The signal at this reference point is the mux data frame, and is defined as the grouping of octets from different bearer channels within the same latency path, after the sync overhead data octets have been added.
C	This reference point is the output of a single latency path

9.1.1 δ interface

The δ_O and δ_R reference points at the VTU-O and VTU-R, respectively, reside between the PMS-TC and the PMD sublayers, as illustrated in Figure 5-2. Both interfaces are functional, are application independent, and are defined by the following signal flows:

- Data flow; and
- Synchronization flow.

The δ interface signals are summarized in Table 9-2.

Table 9-2 – δ interface signal summary

Signal	Description	Direction
<i>Data signals</i>		
Tx	Transmit data stream	PMS-TC → PMD
Rx	Receive data stream	PMS-TC ← PMD
<i>Synchronization signals</i>		
Clkp_t	Transmit bit timing	PMS-TC ← PMD
Clkp_r	Receive bit timing	PMS-TC ← PMD
<i>Control signals</i>		
Syncflag	Reconfiguration flag	PMS-TC ← PMD

9.1.1.1 Data flow

The data flow shall consist of two contra-directional streams of data frames:

- Transmit data frames (Tx);
- Receive data frames (Rx).

The number of bits in each data frame and the number of incoming data frames per second are dependent on the transmission parameters of the PMD sublayer selected during initialization. The bits of the PMS-TC data frame (Figure 9-6) shall be transmitted towards the PMD in sequential order, starting from the first bit of the data frame.

9.1.1.2 Synchronization flow

The synchronization flow shall consist of transmit and receive bit-synchronization signals (Clkp_t, Clkp_r), both originating from the PMD.

9.1.1.3 Control flow

This flow provides a time marker (Syncflag, as specified in Table 9-2) for changes of the PMS-TC parameters during OLR. The Syncflag is asserted by the PMD and indicates a specific time when the PMS-TC shall start operating with modified parameters. The list of the relevant PMS-TC parameters is for further study.

9.2 Scrambler

A scrambler shall be used to reduce the likelihood that a long sequence of ZEROS will be transmitted over the channel. The scrambler shall be self-synchronizing such that descrambling can occur without requiring a particular alignment with the scrambled sequence. The scrambling algorithm shall be as represented by the equation below; the output bit of data $x(n)$ at the sample time n shall be:

$$x(n) = m(n) + x(n - 18) + x(n - 23)$$

where $m(n)$ is the input bit of data at the sample time n . All arithmetic shall be modulo 2.

NOTE – As long as the scrambler is initialized with values other than zero, an "all zeros" sequence for $m(n)$ will result in a pseudo-random sequence of length $2^{23} - 1$.

Incoming bytes shall be input to the scrambler LSB first. All data bytes and OH bytes of every mux data frame (see clause 9.5.1) shall be scrambled.

9.3 Forward error correction

A standard byte-oriented Reed-Solomon code shall be used for forward error correction (FEC). FEC provides protection against random and burst errors. A Reed-Solomon code word shall contain

$N_{FEC} = K+R$ bytes, comprised of R check bytes $c_0, c_1, \dots, c_{R-2}, c_{R-1}$ appended to the K data bytes $m_0, m_1, \dots, m_{K-2}, m_{K-1}$. The check bytes shall be computed from the data bytes using the equation:

$$C(D) = M(D)D^R \bmod G(D)$$

where:

$M(D) = m_0D^{K-1} \oplus m_1D^{K-2} \oplus \dots \oplus m_{K-2}D \oplus m_{K-1}$ is the data polynomial

$C(D) = c_0D^{R-1} \oplus c_1D^{R-2} \oplus \dots \oplus c_{R-2}D \oplus c_{R-1}$ is the check polynomial

$G(D) = \prod (D \oplus \alpha^i)$ is the generator polynomial of the Reed-Solomon code, where the index of the product runs from $i=0$ to $R-1$

The polynomial $C(D)$ is the remainder obtained from dividing $M(D)D^R$ by $G(D)$. The arithmetic shall be performed in the Galois Field GF(256), where α is a primitive element that satisfies the primitive binary polynomial $x^8 \oplus x^4 \oplus x^3 \oplus x^2 \oplus 1$. A data byte $(d_7, d_6, \dots, d_1, d_0)$ is identified with the Galois Field element $d_7\alpha^7 \oplus d_6\alpha^6 \oplus \dots \oplus d_1\alpha \oplus d_0$.

Both K and R shall be programmable parameters. Valid values for the number of check bytes R in the codeword are 0, 2, 4, 6, 8, ..., 16. Valid values for the number of bytes in the codeword N_{FEC} (codeword size) are all integers from 32 to 255, inclusive. A VTU shall support all valid values of R and N_{FEC} .

The FEC for the ROC shall only use $R=16$ and N_{FEC} values from 32 to 66 with $q = 1$.

9.4 Interleaving

Interleaving shall be provided in all supported latency paths to protect the data against bursts of errors by spreading the errors over a number of Reed-Solomon codewords. The convolutional interleaver adopted for VDSL2 shall follow the rule:

- I is the interleaver block size in bytes. Each of the I bytes in an interleaver block $B_0B_1 \dots B_{I-1}$ shall be delayed by the interleaver by an amount that varies linearly with the byte index. More precisely byte B_j (with index j) shall be delayed by $\Delta[j] = (D - 1) \times j$ bytes, where D is the interleaver depth in bytes, and D and I are co-prime (have no common divisor except for 1).

For any interleaver input of size $D \times I$ bytes, the relationship between the index of each input byte (n_{in}) and the index of each output byte (n_{out}) is given by $n_{out} = (n_{in} + \Delta[j])$, where $j = n_{in} \bmod I$ and $\Delta[j] = (D - 1) \times j$.

The total delay of the interleaver/de-interleaver combination is $(D - 1) \times (I - 1)$ bytes.

The RS codeword length N_{FEC} shall be an integer multiple of I , i.e., $N_{FEC} = q \times I$, where q is an integer between 1 and 8 inclusive. All values of q shall be supported. Codewords shall be mapped to interleaver blocks such that the first I bytes of the codeword map to the I bytes $B_0B_1 \dots B_{I-1}$ of the first interleaver block.

The interleaver depth shall be set to meet the requirements for error-burst protection and latency. The VTU shall support all integer values of D from 1 to D_{max} , as specified for the particular profile (see Table 6-1). At any data rate, the minimum latency occurs when the interleaver is turned off. If both latency paths are supported, interleaving shall be supported on both latency paths. The same valid and mandatory configuration parameters shall apply to all supported latency paths.

The interleaving for the ROC shall only use D values up to 20.

A summary of interleaver parameters is given in Table 9-3.

Table 9-3 – Summary of interleaver parameters

Parameter(s)	Value for:	Value for:
	<ul style="list-style-type: none"> • single latency mode (latency path #0) • dual latency mode (latency paths #0 and #1) • single latency with ROC mode (latency path #1) 	single latency with ROC mode (latency path #0)
D and I	Co-prime	Co-prime
q	Integer between 1 and 8, inclusive	1
N_{FEC}	Integer between 32 and 255 inclusive, $N_{FEC} = q \times I$	Integer between 32 and 66 inclusive, $N_{FEC} = q \times I$
Total delay of the interleaver/de-interleaver combination	$(D-1) \times (I-1)$ bytes	$(D-1) \times (I-1)$ bytes

9.4.1 Dynamic change of interleaver depth

A method to dynamically change the interleaver depth during transmission is defined for VDSL2. This method is optional. Support shall be indicated during initialization in O-MSG 1 and R-MSG 2.

NOTE – Although this clause defines the procedure for dynamically changing the interleaver depth during transmission, the control command for initiating this procedure is not defined in this version of in this Recommendation. The calling procedure for dynamic change of interleaver depth will be defined in a future revision to this Recommendation.

A change of the interleaver depth shall only be initiated at the first byte of an RS codeword, where k is the sequence number of this byte at the input of the interleaver.

For an increase of the interleaver depth from D_{old} to D_{new} with $D_{old} < D_{new}$ the interleaver output is defined by:

$$y(n + \Delta_{old}[j]) = x(n); \text{ for } n + \Delta_{old}(j) < k, \text{ where } \Delta_{old}[j] = (D_{old} - 1) \times j$$

$$y(n + \Delta_{new}[j]) = x(n); \text{ for } n + \Delta_{old}(j) \geq k, \text{ where } \Delta_{new}[j] = (D_{new} - 1) \times j$$

For a decrease of the interleaver depth from D_{old} to D_{new} with $D_{old} > D_{new}$ the interleaver output is defined by:

$$y(n + \Delta_{old}[j]) = x(n); \text{ for } n + \Delta_{new}(j) + \delta < k$$

$$y(n + \Delta_{new}[j] + \delta) = x(n); \text{ for } n + \Delta_{new}(j) + \delta \geq k$$

where δ is the length of the transition and is given by:

$$\delta = \lceil (D_{old} - D_{new}) \cdot (I - 1) / I \rceil \cdot I$$

δ is not a persistent delay; it can be compensated by interrupting the interleaver input by the time represented by δ bytes.

The values of bytes that are not defined by the rules above are unspecified.

If a change of the interleaver depth is to be accompanied by a corresponding change of the data rate in the particular latency path (e.g., SRA – see clause 13.1), the change of D shall be coordinated with the corresponding change of parameter L_p (see Table 9-8) as described in clause 13.3.

Dynamic change of interleaver depth shall not be used for the ROC.

9.5 Framing

The framing format of a single latency path is summarized in Figures 9-2 and 9-3. Both latency paths have the same framing format, but their framing parameters (specified in Table 9-8) are independent. Index p indicates the latency path and may take values 0 and 1.

9.5.1 Mux data frame (MDF) and RS codewords

The overhead channel and the first and second bearer channels are multiplexed into the mux data frames (MDF). The format of the MDF is presented in Figure 9-3. To form the MDF, the PMS-TC pulls out sequentially O_{pi} octets from the overhead (OH) buffer and then B_{p0} and B_{p1} octets from the first and the second bearer channel buffers, respectively.

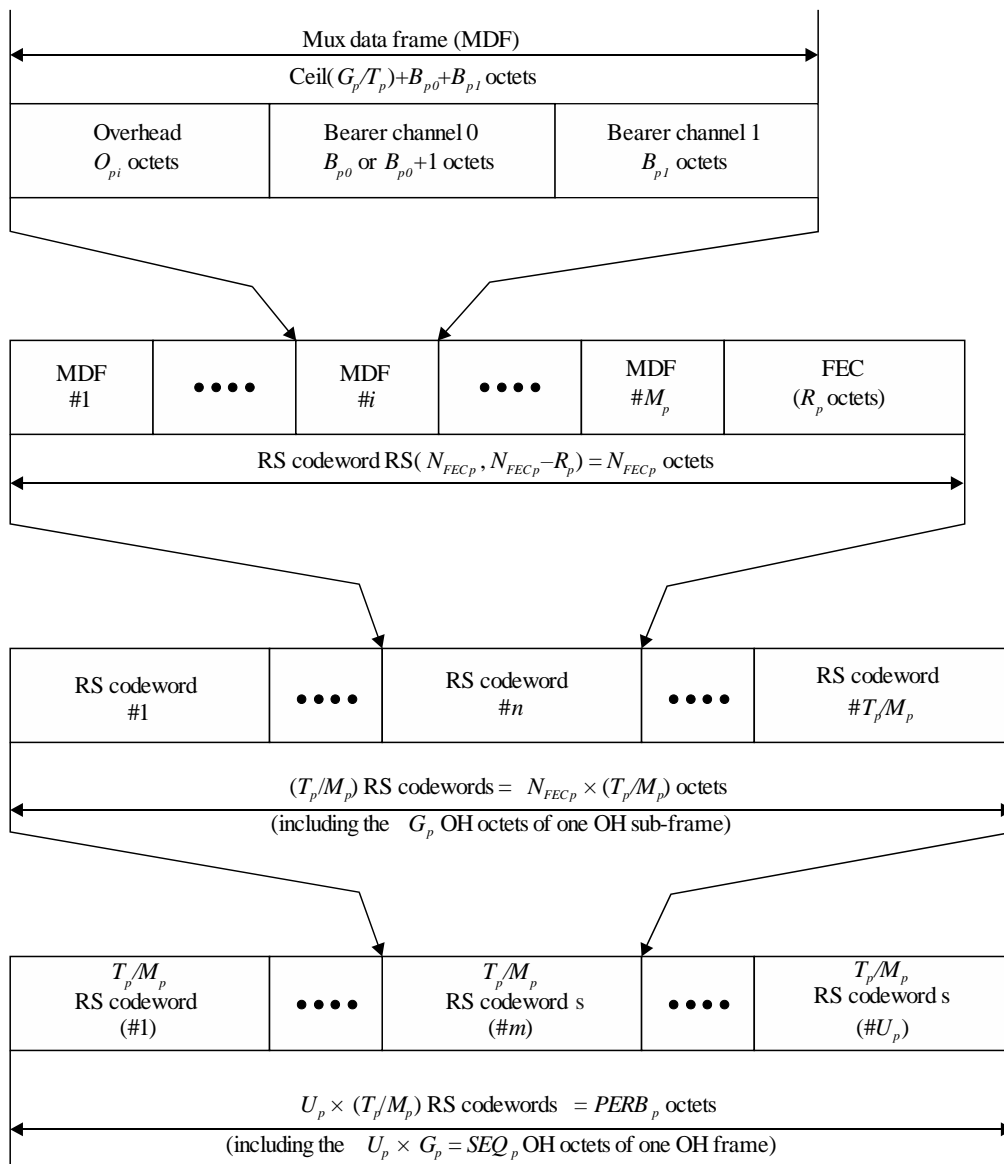

G.993.2(15)_F9-3

Figure 9-3 – MDF and RS codeword structure

MDFs are mapped to an RS codeword as presented in Figure 9-3. Each RS codeword includes the same integer number, M_p , of MDFs and the same number of redundancy octets R_p ; the first octet of each codeword is the first octet of the first MDF of this codeword. The total size of the RS codeword

is N_{FECp} bytes. All octets in the bearer channel fields of the MDF shall be mapped to transmit LSB first. The bits of the overhead octets shall be mapped as specified in clause 9.5.2.2.

The number O_{pi} of overhead octets per MDF shall be as specified in clause 9.5.2.1. Because of the way overhead octets are assigned to MDFs, the number of overhead octets in an MDF can vary by up to one octet. Those MDFs with one fewer overhead octets shall instead carry one additional octet from bearer channel #0 so that the total number of octets in all MDFs is the same.

NOTE – The ratio of the bit rates of two bearer channels may not exactly fit the real ratio of the transmitted bit rates. The setting of the bit rate ratio has a finer granularity for larger MDFs.

9.5.2 Overhead (OH) frame, subframe and superframe

The OH frame carries the OH data and framing synchronization. The OH frame consists of an integer number U_p of OH subframes, as shown in Figure 9-4. All OH subframes have the same format. The total length of the OH frame (the OH frame period) is $PERB_p$ octets. The OH frame parameters U_p and $PERB_p$ are specified in Table 9-8.

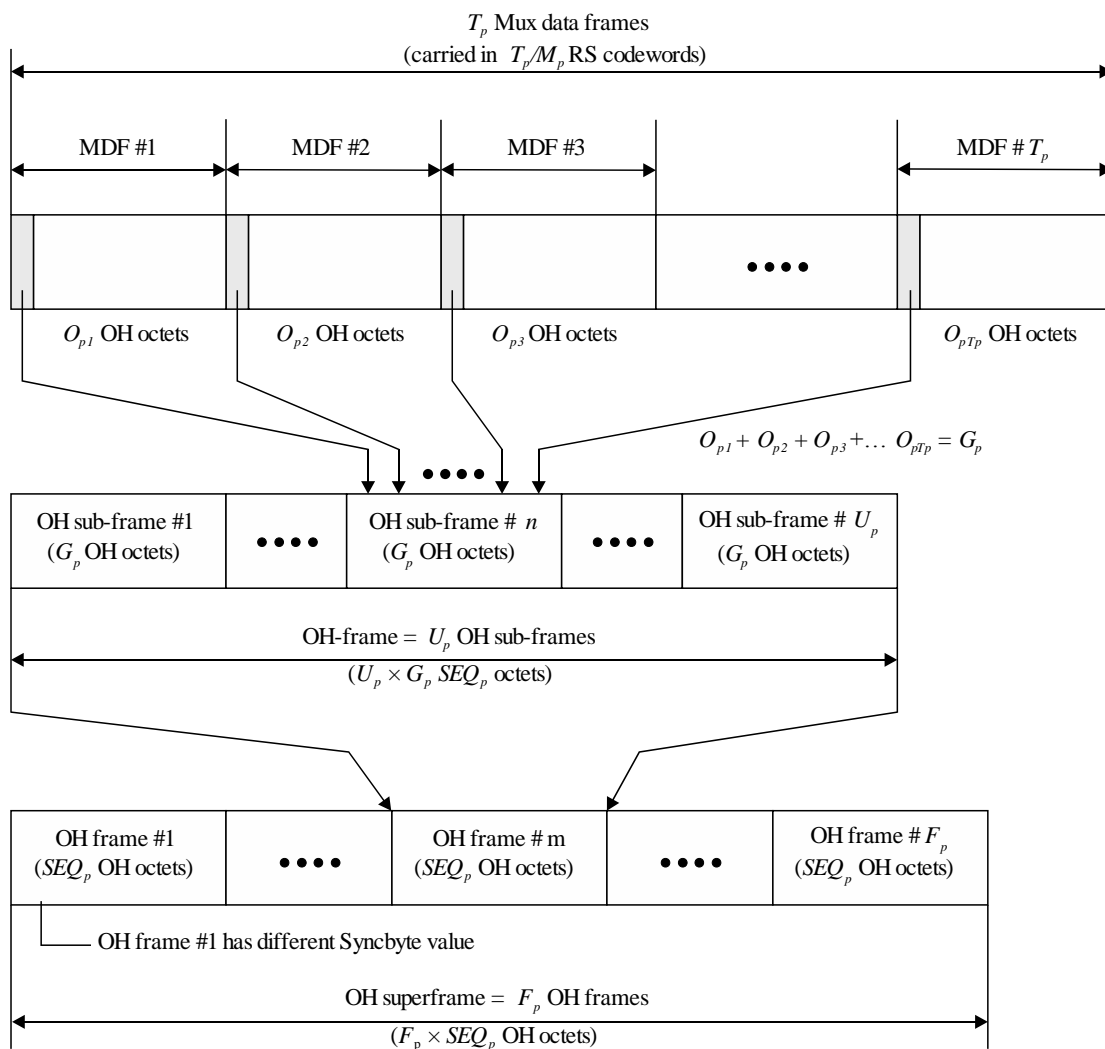

G.993.2(15)_F9-4

Figure 9-4 – Overhead subframe, frame, and superframe structure

An OH superframe is composed of F_p OH frames.

9.5.2.1 OH subframe format

The OH subframe spans T_p MDFs and includes G_p OH octets distributed among these MDFs. The number of OH octets, O_{pi} , in MDF # i of the OH subframe shall be:

$$O_{pi} = \begin{cases} \left\lceil \frac{G_p}{T_p} \right\rceil & \text{for } i \leq G_p - T_p \times \left\lfloor \frac{G_p}{T_p} \right\rfloor, \\ \left\lfloor \frac{G_p}{T_p} \right\rfloor & \text{otherwise} \end{cases}, \quad i = 1, 2, \dots, T_p; 0 \leq O_{pi} \leq 8.$$

Settings for G_p and T_p shall comply with the following rules:

Rule 1: $M_p/S_p \leq 64$;

$$\text{Rule 2: } \left\lfloor \frac{G_p}{T_p} \right\rfloor \times \left\lfloor \frac{M_p}{S_p} \right\rfloor + \left\lceil \frac{\frac{M_p}{S_p}}{T_p} \right\rceil \times (G_p \bmod T_p) + \min \left(\left\lceil \frac{M_p}{S_p} \right\rceil \bmod T_p, G_p \bmod T_p \right) \leq 8$$

The valid range of the number of OH octets in MDF O_{pi} is from 0 to 8; the valid range of the number of OH octets in the OH subframe G_p is from 1 to 32.

The OH subframe shall span an integer number of RS codewords: $T_p = k \times M_p$, where k is an integer.

NOTE 1 – The average number of OH octets per MDF is equal to G_p/T_p and can be a non-integer.

NOTE 2 – Since the OH frame spans an integer number of RS codewords and an integer number of MDFs, the boundaries of the OH frame, the RS codeword, and the MDF are aligned.

9.5.2.2 Mapping of the OH data

The mapping of the OH data to the OH frame shall be as presented in Table 9-4. Two types of OH frames shall be supported:

Type 1 – Full frame;

Type 2 – Auxiliary frame.

For single latency, the latency path shall use OH frame Type 1. For Dual Latency, one latency path shall use OH frame Type 1 and the other shall use OH frame Type 2. For single latency with ROC, the ROC (in latency path 0) shall use OH frame Type 1 and latency path 1 shall use OH frame Type 2. The latency path selected for OH frames of Type 1 shall be indicated during initialization by the parameter value in the MSGLP field (see clauses 12.3.5.2.1.3 and 12.3.5.2.2.3). When the ROC is used, MSGLP (see Tables 12-56 and 12-60) shall have the value 0.

Table 9-4 – Contents of Type 1 and Type 2 OH frames

OH frame Type 1		
Octet number	OH field	Description
1	CRC _p	Cyclic redundancy check (clause 9.5.2.3)
2	Syncbyte	Syncbyte = AC ₁₆ when the OH frame indicates the start of an OH superframe, otherwise Syncbyte = 3C ₁₆
3	IB-1	PMD-related primitives (Note 1, Table 9-5)
4	IB-2	PMS-TC-related primitives (Note 1, Table 9-5)

Table 9-4 – Contents of Type 1 and Type 2 OH frames

OH frame Type 1		
Octet number	OH field	Description
5	IB-3	TPS-TC-related and system-related primitives (Note 1, Table 9-5)
6	NTR	Network timing reference (Note 2, clause 8.3)
>6	MSG	Message overhead (Note 3, clause 11.2)
OH frame Type 2		
1	CRC _p	Cyclic redundancy check (clause 9.5.2.3)
2	Syncbyte	Syncbyte = AC ₁₆ when the OH frame indicates the start of an OH superframe, otherwise Syncbyte = 3C ₁₆
3	Reserved for allocation by ITU-T	The value for the reserved field shall be FF ₁₆
>3	Reserved for allocation by ITU-T	The value for the reserved field shall be FF ₁₆ (Note 4)

NOTE 1 – The IB (indicator bits) inform the far end of anomalies and defects; valid in both directions for OH frames of Type 1. IB that are not used shall be set to ONE.

NOTE 2 – The NTR (network timing reference) provides an 8 kHz timing reference for the CPE; valid only in the downstream direction for OH frames of Type 1. If the VTU-O indicates that it will not transport NTR, the NTR field shall also be set to FF₁₆. In the upstream direction, the NTR field shall always be set to FF₁₆.

NOTE 3 – The MSG field transports eoc messages; valid in both directions only for OH frames of Type 1.

NOTE 4 – If the "flexible OH frame Type 2" is not supported (see clauses 12.3.5.2.1.1 (O-MSG1) and clause 12.3.5.2.2.1 (R-MSG2)), the number of additional reserved octets shall be equal to 5, i.e., the OH frame Type 2 shall contain 8 octets. If the "flexible OH frame Type 2" is supported, the number of additional octets is determined by the selected framing parameters.

Mapping of the CRC, IB and NTR bits to the OH frame fields shall be as specified in Table 9-5; the LSB shall be transmitted first. Mapping of the MSG bytes into the OH frame shall be LSB first, as specified in clauses 8.2.3 and 9.1.

Table 9-5 – OH bit mapping

OH field	D7(MSB)	D6	D5	D4	D3	D2	D1	D0(LSB)	Defined in
CRC	<i>crc₇</i>	<i>crc₆</i>	<i>crc₅</i>	<i>crc₄</i>	<i>crc₃</i>	<i>crc₂</i>	<i>crc₁</i>	<i>crc₀</i>	9.5.2.3
IB-1	<i>los</i>	<i>rdi</i>	<i>lpr</i>	1	1	1	1	1	11.2.4, 11.3
IB-2	1	1	1	1	1	1	1	1	
IB-3	TIB#0-0	TIB#0-1	TIB#0-2	TIB#0-3	TIB#1-0	TIB#1-1	TIB#1-2	TIB#1-3	11.2.4, Annex L
NTR	<i>ntr₇</i>	<i>ntr₆</i>	<i>ntr₅</i>	<i>ntr₄</i>	<i>ntr₃</i>	<i>ntr₂</i>	<i>ntr₁</i>	<i>ntr₀</i>	8.3

9.5.2.2.1 Communication of ToD Frequency Synchronization Data via OH frame Type 1

Table 9-6 shows the modified OH frame Type1 structure for passing the ToD frequency synchronization data (i.e., ToD phase difference and corresponding *t*₁ event number) from the VTU-O to the VTU-R. Octet number 7, the ToD_FSsync octet, is inserted after the NTR octet prior to the

MSG field. The ToD frequency synchronization data is sent in a ToD_FSync Frame that contains three octets: one octet contains the 6 bits of the t_1 event number, and two octets identifying the 16-bit ToD phase difference value. One octet of the ToD_FSync Frame is transmitted in each OH frame, so the ToD_FSync Frame spans three OH frame periods (PER_p). Table 9-7 defines the frame format structure of the ToD_FSync Frame. Special values for the Syncbyte are used to identify the beginning of the ToD_FSync Frame.

The VTU-O shall insert the ToD frequency synchronization data in the OH frame once per super-frame for each t_1 event. The value of $PER_p \leq 20$ ms. Therefore the ToD_FSync frame spans less than a super-frame period, and occasionally a ToD phase difference and corresponding t_1 event number may need to be transmitted twice.

The ToD Frequency Synchronization data should be sent in the first available OH frame immediately following the t_1 event.

The value of the capacity of the MSG channel is reduced by one octet, so the message overhead data rate for the updated OH frame Type 1 is $msg_p = OR_p \times (SEQ_p - 7) / SEQ_p$ and the upper lower msg_p rates are scaled accordingly (see the msg_p entry in Table 9-8). The above frame structure shall be used if and only if during initialization the time synchronization is enabled and the OH frame is selected for the transport of the ToD phase difference values.

Table 9-6 – Modified OH frame Type 1 with ToD frequency synchronization frame extension

OH frame Type 1		
Octet number	OH field	Description
1	CRC _p	Cyclic redundancy check (clause 9.5.2.3)
2	Syncbyte	Values for the Syncbyte are defined in Figure 9-5
3	IB-1	PMD-related primitives (Note 1, Table 9-4)
4	IB-2	PMS-TC-related primitives (Note 1, Table 9-4)
5	IB-3	TPS-TC-related and system-related primitives (Note 1, Table 9-4)
6	NTR	Network timing reference (Note 2, clause 8.3)
7	ToD_FSync	One Byte of ToD FSync Frame (Table 9-7)
> 7	MSG	Message overhead (Note 3, clause 11.2)

Table 9-7 – ToD_FSync frame structure

Octet number	OH field	Description
1	[0 0 c ₅ c ₄ c ₃ c ₂ c ₁ c ₀]	t_1 event number
2	[b ₇ ... b ₂ b ₁ b ₀]	Lower byte of the ToD phase difference value
3	[b ₁₅ ... b ₁₀ b ₉ b ₈]	Higher byte of the ToD phase difference

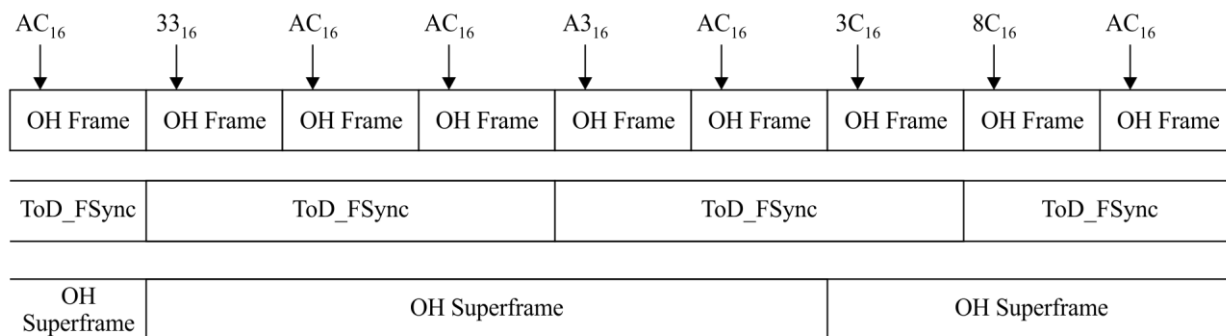

G.993.2(15)_F9-5

Key

AC_{16} = OH frame start

$3C_{16}$ = Syncbyte = OH Superframe start

$A3_{16}$ = ToD_FSync start

33_{16} = Common ToD_FSync and OH Superframe start

Figure 9-5 – Definition of OH sync byte values

9.5.2.3 Cyclic redundancy check (CRC)

A one-byte cyclic redundancy check (CRC) shall be computed for each OH frame period of each latency path separately. For a t -bit data message transmitted during the OH frame period, the CRC shall be computed using the following equation:

$$crc(D) = M(D) \times D^8 \text{ modulo } G(D),$$

where:

$M(D) = m_0D^{t-1} + m_1D^{t-2} + \dots + m_{t-2}D + m_{t-1}$ is the data message polynomial,

$G(D) = D^8 + D^4 + D^3 + D^2 + 1$ is the generating polynomial,

$crc(D) = crc_0D^7 + crc_1D^6 + \dots + crc_6D + crc_7$ is the CRC polynomial, and

D is the delay operator.

That is, $crc(D)$ shall be the remainder when $M(D) \times D^8$ is divided by $G(D)$. Each octet of the data message shall be input into the $crc(D)$ equation LSB first.

The values of crc_0 to crc_7 are the CRC bits to be carried in the next OH frame as specified in clause 9.5.2.2 so that the LSB (crc_0) is transmitted first. The CRC bits of the first OH frame (at the entrance into showtime) shall be set to ZERO.

The CRC shall be computed prior to scrambling for each subsequent period of time equal to the duration of the OH frame in bytes ($PERB_p$). The data message covered by the CRC shall include all bits of all MDFs transmitted during the period of the OH frame, except the CRC byte. The first CRC shall be computed over the data message that includes the first OH frame period (after the entrance into showtime); the second CRC shall be computed over the data message that includes the second OH frame period; and so on.

9.5.2.4 OH superframe

The OH superframe contains F_p OH frames and is intended to provide an additional timing reference. The value of F_p shall be selected so that the duration of the OH superframe is significantly longer than the time required to exchange management information between the VTU-O and the VTU-R. The first octet of the OH superframe coincides with the first octet of the OH frame and shall be marked by Syncbyte = AC_{16} . The valid range of F_p is from 1 to 255.

9.5.3 Multiplexing of data from two latency paths

9.5.3.1 Robust overhead channel (ROC)

As defined in clause 9.5.2.2, all overhead traffic is mapped into one of the latency paths. Optionally, the VTUs may negotiate an ROC (see clause 9.1). The ROC is effectively a latency path that carries only overhead data. When the ROC is enabled (single latency with ROC mode), all overhead data (see clause 11.2.3.3) shall be sent through latency path #0. In this mode, latency path #0 is also referred to as the robust overhead channel.

9.5.3.2 Multiplexing

The assigned number of bits, L_0 and L_1 , from the RS codewords of latency paths #0 and #1, respectively, shall be mapped to the data frame as shown in Figure 9-6. The bits shall be extracted from the octets of the RS codewords in sequential order, LSB first. The first bit of each extracted group of L_0 bits shall be the first bit of the data frame. When the VTU operates in single latency with ROC mode (see clause 9.1), L_0 shall be an integer number of bytes consisting of overhead data only.

When single latency with ROC mode is enabled, the L_0 bits shall not share the same subcarriers with L_1 bits.

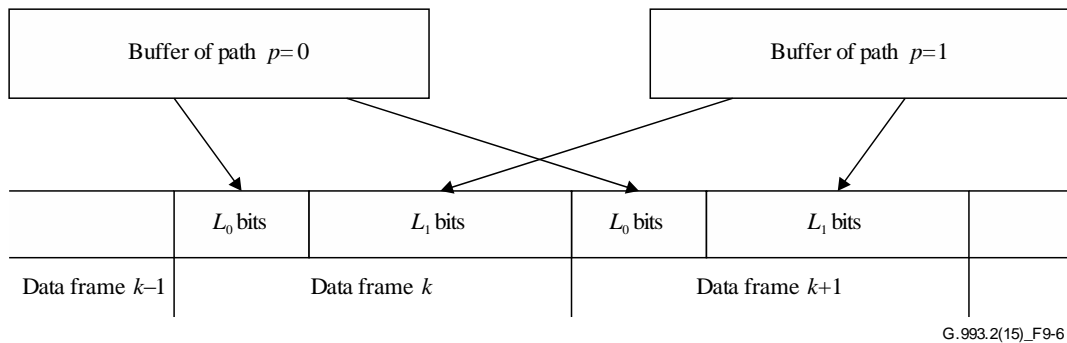

Figure 9-6 – Multiplexing of two latency paths into data frames carried by DMT symbols

9.5.4 Framing parameters

Framing parameters for latency path p are specified in Table 9-8. Two groups of parameters are specified:

- Primary framing parameters; and
- Derived framing parameters.

Primary framing parameters are those communicated to the other VTU during initialization for frame setup (see clause 12.3.5). Derived framing parameters are computed by the VTU using the primary framing parameters to establish the complete frame setting and parameters intended for verification of the data channel and overhead channel bit rates and provide other important characteristics of the PMS-TC when specific framing parameters are set.

Table 9-8 – Framing parameters for latency path p

Parameter	Definition
Primary framing parameters	
B_{pn}	The number of octets from bearer channel # n per MDF. The range of values is from 0 to 254. When G_p/T_p is not an integer, the number of octets from the bearer channel #0 varies between B_{p0} and $B_{p0} + 1$.
R_p	The number of redundancy octets in the RS codeword.
M_p	The number of MDFs in an RS codeword. Only values of 1, 2, 4, 8 and 16 shall be supported.
T_p	The number of MDFs in an OH subframe; $T_p = k \times M_p$, where k is an integer. The value of T_p shall not exceed 64.
G_p	The total number of overhead octets in an OH subframe; $1 \leq G_p \leq 32$.
F_p	Number of OH frames in the OH superframe. $1 \leq F_p \leq 255$.
L_p	The number of bits from latency path p transmitted in each data symbol.
Derived framing parameters	
N_{FECp}	The RS codeword size: $N_{FECp} = M_p \times \left[\text{ceiling} \left(\frac{G_p}{T_p} \right) + B_{p0} + B_{p1} \right] + R_p \text{ bytes}$
O_{pi}	<ul style="list-style-type: none"> The number of overhead octets in the i^{th} MDF of the OH subframe: $O_{pi} = \begin{cases} \left\lceil \frac{G_p}{T_p} \right\rceil & \text{for } i \leq G_p - T_p \times \left\lfloor \frac{G_p}{T_p} \right\rfloor, i = 1, 2, \dots, T_p; \\ \left\lfloor \frac{G_p}{T_p} \right\rfloor & \text{otherwise} \end{cases}, 0 \leq O_{pi} \leq 8.$
$PERB_p$	<p>The number of bytes in the overhead frame:</p> $PERB_p = \frac{T_p \times N_{FECp}}{M_p} \times \left\lfloor \frac{\hat{Q} \times M_p}{T_p \times N_{FECp}} \right\rfloor \text{ bytes}$ <p>where:</p> $\hat{Q} = \begin{cases} Q & \text{if } TDR_p \geq TDR_0 \\ Q \cdot \frac{TDR_p}{TDR_0} & \text{if } TDR_p < TDR_0 \end{cases}$ <p>and where:</p> <ul style="list-style-type: none"> TDR_p is the total data rate of latency path p in kbit/s, $Q = 17\,000$ bytes, $TDR_0 = 7\,880$ kbit/s.

Table 9-8 – Framing parameters for latency path p

Parameter	Definition
TDR_p	The total data rate of latency path p (at reference point C): $TDR_p = L_p \times f_s$ kbit/s, where f_s is the data symbol rate in ksymbols/s (see clause 10.4.4).
S_p	The number of data symbols over which the RS codeword spans, $S_p = \frac{8 \times N_{FECp}}{L_p}$ The value of S_p may be a non-integer, and shall not exceed 64.
NDR_{pn}	The net data rate for bearer channel #0: $NDR_{p0} = \left[B_{p0} + \text{ceiling} \left(\frac{G_p}{T_p} \right) - \frac{G_p}{T_p} \right] \times \frac{8 \times M_p \times f_s}{S_p} \text{ kbit/s.}$ The net data rate for bearer channel #1: $NDR_{p1} = B_{p1} \times \frac{8 \times M_p \times f_s}{S_p} \text{ kbit/s.}$ The settings of framing parameters shall provide $net_{min_n} < NDR_{pn} < net_{max_n}$ for all defined bearer channels over relevant latency paths.
NDR_p	The net data rate for latency path p : $NDR_p = L_p \times f_s \times \frac{K_p}{N_{FECp}} - OR_p = \left(K_p - \frac{G_p \times M_p}{T_p} \right) \times \frac{8 \times f_s}{S_p} \text{ kbit/s.}$ where $K_p = N_{FECp} - R_p$.
U_p	The number of OH subframes in the OH frame: $U_p = \frac{PERB_p}{N_{FECp}} \times \frac{M_p}{T_p}$
SEQ_p	The number of overhead bytes in the OH frame: $SEQ_p = U_p \times G_p \text{ bytes.}$
OR_p	The overhead data rate for latency path p : $OR_p = \frac{G_p \times M_p}{S_p \times T_p} \times 8 \times f_s \text{ kbit/s.}$
msg_p	The message overhead data rate (for OH frame Type 1 only, excluding the ToD_FSync octet – see Table 9-6): $msg_p = OR_p \times \frac{SEQ_p - 6}{SEQ_p} \text{ kbit/s.}$ The settings of framing parameters shall provide $msg_{min} < msg_p < msg_{max}$. The settings for msg_{min} and msg_{max} shall comply with the following conditions: $16 \text{ kbit/s} \leq msg_{min} \leq 236 \text{ kbit/s}; msg_{max} = 256 \text{ kbit/s.}$ The message overhead data rate (for OH frame Type 1 including the ToD_FSync octet – see Table 9-6): $msg_p = OR_p \times (SEQ_p - 7) / SEQ_p \text{ kbit/s.}$

Table 9-8 – Framing parameters for latency path p

Parameter	Definition
PER_p	The duration of the overhead frame in ms (Note): $PER_p = \frac{T_p \times S_p \times U_p}{f_s \times M_p} = \frac{8 \times PERB_p}{L_p \times f_s} \text{ ms.}$
<p>NOTE – In clauses 7.2.1.1.3 and 7.2.1.2.3 of [ITU-T G.997.1], a one-second counter is used to declare a near-end severely errored second (SES). The one-second counter shall be incremented by the $\Delta CRCsec_p$ (the one-second normalized CRC anomaly counter increment) for each occurrence of a $crc-p$ anomaly. A $\Delta CRCsec_p$ value is defined for each downstream and upstream latency path separately, as a real value in the 0.125 to 8 range, as:</p> $\Delta CRCsec_p = \begin{cases} 1 & \text{if } 15 \leq PER_p \leq 20 \\ \frac{PER_p}{15} & \text{if } PER_p < 15 \end{cases}$	

9.5.5 Parameter 1/S

Parameter 1/S defines the total number of Reed-Solomon codewords decoded within a single data symbol. It is equal to:

$$1/S = \sum_p \text{ceiling} \left(\frac{1}{S_p} \right)$$

where S_p is the number of data symbols over which the RS codeword of latency path p spans, and the sum is over all enabled latency paths. The value of S_p may be non-integer, and shall be computed as specified in Table 9-8.

The range of 1/S values ($1/64 \leq 1/S \leq (1/S)_{max}$) is profile dependent. The mandatory values of $(1/S)_{max}$ for different profiles are defined in Table 6-1. Optional extended (valid) values of $(1/S)_{max}$ for different profiles are specified in Table 9-9.

Table 9-9 – Optional extended values of $(1/S)_{max}$

Parameter	Parameter value for profile							
	8a	8b	8c	8d	12a	12b	17a	30a
$(1/S)_{max}$ downstream	64	64	64	64	64	64	64	32
$(1/S)_{max}$ upstream	32	32	32	32	64	64	64	32

9.6 Impulse noise protection (INP_p)

INP_p (impulse noise protection for latency path p) is defined as the number of consecutive DMT symbols or fractions thereof, as seen at the input to the de-interleaver, for which errors can be completely corrected by the error correcting code, regardless of the number of errors within the errored DMT symbols.

NOTE 1 – This is equivalent to the number of consecutive errored octets within any block of $(I_p - 1) \cdot D_p + 1$ octets, as seen at the input to the de-interleaver, for which errors can be completely corrected by the error correcting code, divided by $L_p/8$, the number of octets loaded in a DMT symbol for latency path p . The interleaver block length, I_p , and interleaver depth, D_p , are defined in clause 9.4, and the number of bits from latency path p loaded into a DMT symbol, L_p , is defined in clause 9.5.4.

NOTE 2 – The value of INP_p is given in terms of DMT symbols. The time span of impulse noise protection, in ms, varies with subcarrier spacing as determined by the profile (see clause 6) and with the CE length (see clause 10.4.4).

The actual impulse noise protection INP_{act_n} of bearer channel # n shall always be set to the value of the derived parameter INP_p of the underlying PMS-TC path function (see Annex L). The receiver shall always ensure $INP_{act_n} \geq INP_{min_n}$ according to the definition of INP_p regardless of any vendor-discretionary techniques including, for example, the use of erasure decoding. When the Reed-Solomon decoder in the receiver does not use erasure decoding, the INP_p shall be computed as:

$$INP_{no_erasure_p} = \frac{8 \times D_p \times \left\lfloor \frac{R_p}{2 \times q_p} \right\rfloor}{L_p} = \frac{S_p \times D_p \times \left\lfloor \frac{R_p}{2 \times q_p} \right\rfloor}{N_{FECp}} \text{ DMT symbols}$$

where parameters D_p , R_p , L_p , and q_p are defined in clauses 9.4 and 9.5.4. When erasure decoding is used, INP_p might not equal $INP_{no_erasure_p}$.

For single latency with ROC mode, the value $INP_{no_erasure_p}$ for latency path #0 (the ROC) shall comply with:

$$INP_{no_erasure_0} \geq \text{INPMIN-ROC (see clause 12.3.5.2.1.1)}$$

Within this equation, INPMIN-ROC is expressed in DMT symbols.

The VTU-O shall calculate INPMIN-ROcus (in DMT symbols) from the CO-MIB value INPMIN-ROC-us (defined in clause 7.3.1.10.12 of [ITU-T G.997.1] in multiples of T_{4k}), and the VTU-R shall calculate INPMIN-ROcds (in DMT symbols) from the O-MSG 1 parameter INPMIN-ROC-ds value (defined in field #23 in multiples of T_{4k}) as follows:

For 4.3125 kHz subcarrier spacing:

INPMIN-ROC in DMT symbols = INPMIN-ROC in multiples of T_{4k} .

For 8.625 kHz subcarrier spacing:

INPMIN-ROC in DMT symbols = $2 \times$ (INPMIN-ROC in multiples of T_{4k}).

with T_{4k} as defined in clause 10.4.4.

During initialization, the VTU-O, under direction from the CO-MIB, can set a bit in initialization to require that the VTU-R receiver select framing parameters so that $INP_p = INP_{no_erasure_p}$ on both latency paths. Regardless of whether this bit is set, the receiver shall always ensure $INP_{act_n} \geq INP_{min_n}$. This bit is referred to as "INP_no_erasure_required", bit 8 in the "Impulse noise protection" field in Table 12-51, clause 12.3.5.2.1.1.

During initialization, the VTU-R declares if it is using erasure decoding on either latency path. This field is referred to as "Erasure decoding used" in Table 12-64, clause 12.3.5.2.2.3.

Erasure decoding is vendor discretionary at both VTUs.

9.7 Delay

When the interleaver is disabled (interleaver depth = 1), the one-way delay between the α and β interfaces shall not exceed 2 ms.

The actual delay in milliseconds introduced by the interleaver to latency path p shall be computed as:

$$delay_p = \frac{S_p \times (D_p - 1)}{q_p \times f_s} \times \left(1 - \frac{q_p}{N_{FECp}} \right) \text{ ms}$$

where D_p is the interleaving depth set for the latency path p , S_p is the parameter defined in Table 9-8,

q_p is the number of interleaver blocks in an FEC codeword for latency path p , N_{FECp} is the FEC codeword size for latency path p , and f_s is the data symbol rate in ksymbols/s.

The interleaver delay in milliseconds for the specific bearer channel n is constrained by the value of $delay_max_n$ defined in the CO-MIB.

For single latency with ROC mode, the value $delay_p$ for latency path #0 (the ROC) shall comply with:

$$delay_0 \leq 8 \text{ ms}$$

Additionally, the framing parameters of the latency path #0 (the ROC) shall be chosen such that the ROC is robust to repetitive impulse noise at a frequency of 120 Hz. This may be achieved by selecting the framing parameters such that:

$$\frac{8 \times N_{FEC0} \times D_0}{L_0} \leq \left\lfloor \frac{f_s}{120 \text{ Hz}} \right\rfloor - 1$$

9.8 Bit error ratio (BER)

The bit error ratio (BER), referenced to the output of the α/β interface of the receiver, shall not exceed 10^{-7} for any of the supported bearers. The VTU shall implement appropriate initialization and reconfiguration procedures to assure this value.

9.9 Delay variation

The delay variation occurring in an OLR on latency path p .

It is defined here as:

$$DV_p = \left| (delay_{p_H} \times L_{p_H} - delay_{p_L} \times L_{p_L}) / L_{p_H} \right|$$

where:

L_{p_L} is the lower value of L_p in an OLR procedure

L_{p_H} is the higher value of L_p in an OLR procedure

$delay_{p_L}$ = the actual delay in ms in the steady state corresponding with L_{p_L}

$delay_{p_H}$ = the actual delay in ms in the steady state corresponding with L_{p_H}

The delay variation DV_n of bearer channel # n shall always be set to the value of DV_p of the underlying PMS-TC path function (see Annex L).

10 Physical media dependent (PMD) function

During showtime, the transmit PMD function shall transmit a number of data symbols per second that is dependent on the choice of CE length (see clause 10.4.4) and subcarrier spacing (see clause 10.4.2). For each data symbol, the transmit PMD function receives a symbol encoder input data frame (containing L data bits) from the transmit PMS-TC function. The data frame shall then be symbol encoded as defined in clause 10.3. The symbol encoding will generate a complex value for each subcarrier in the MEDLEY set (either MEDLEY_{us} or MEDLEY_{ds}, depending on the transmission direction, resulting in NSC_{us} and NSC_{ds} complex values respectively). These complex values shall be modulated into data symbols as defined in clause 10.4 to produce an analogue signal for transmission across the digital subscriber line.

10.1 PMD functional model

The functional model of the PMD sublayer is presented in Figure 10-1. In the transmit direction, the PMD sublayer receives input data frames from the PMS-TC sublayer via the δ interface as specified in clause 9.1. Each data frame contains an integer number of data bits equal to $L_0 + L_1$ to be modulated

onto one DMT symbol. Prior to modulation, the incoming bits are encoded by the symbol encoder. The encoder divides the incoming bit stream into small groups of bits, where each group is assigned to modulate a specific subcarrier of the DMT signal. Each group is further encoded by the trellis encoder and mapped to a point in a signal constellation. The set of constellation points modulates the subcarriers of the DMT symbol using an inverse discrete Fourier transform (IDFT). The number of bits assigned to each subcarrier is determined during the initialization procedure based on the SNR of the subcarrier and specific system configuration settings. After the IDFT, the resulting symbol is cyclically extended and windowed, and sent towards the transmission medium over the U interface.

In the receive direction, the signal incoming from the transmission medium via the U interface is demodulated and decoded to extract the transmitted data frame. The data frame obtained from the decoder (denoted "Data frame (output)" in Figure 10-1) is sent to the PMS-TC sublayer via the δ interface.

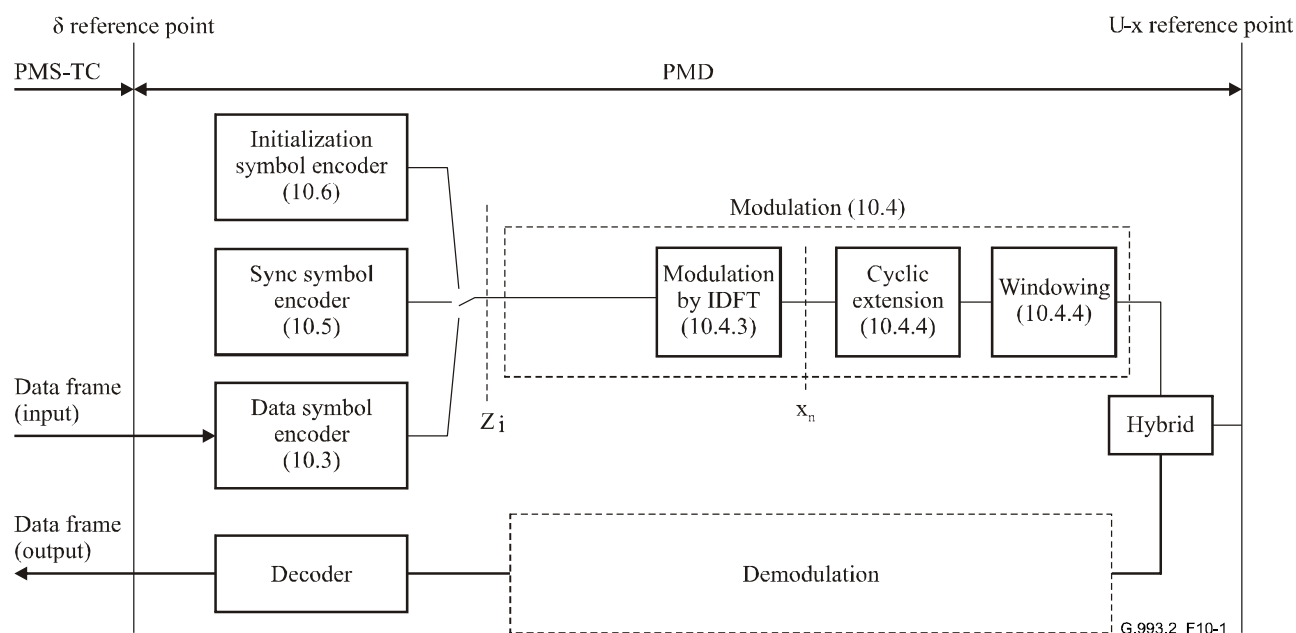

Figure 10-1 – Functional model of PMD sublayer

10.2 DMT superframe

The transmit PMD function shall use the DMT superframe structure shown in Figure 10-2. Each DMT superframe shall be composed of 256 data frames, numbered from 0 to 255, followed by a single sync frame. The content of the sync frame is dependent on whether timing for on-line reconfiguration is being signalled (see clause 10.5.3). The data frames are modulated onto 256 data symbols, and the sync frame is modulated onto a sync symbol as defined in clause 10.5.1. The sync symbol provides a time marker for on-line reconfiguration (see clause 13).

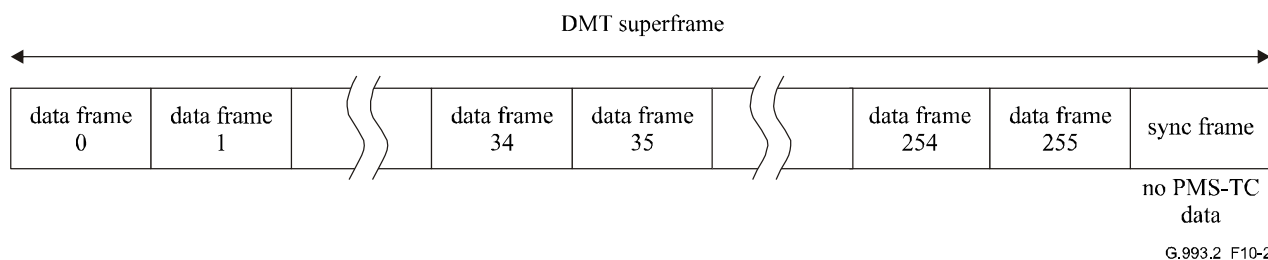

Figure 10-2 – DMT superframe structure

NOTE – The duration of a superframe depends on the subcarrier spacing and value of the cyclic extension (see clause 10.4). When the subcarrier spacing is 4.3125 kHz and the mandatory cyclic extension value is used (5/64), the duration of a superframe is 64.25 ms.

10.3 Symbol encoder for data symbols

The symbol encoder for data symbols is shown as part of the transmit PMD function in Figure 10-1. The symbol encoder for data symbols consists of the following functions:

- Tone ordering;
- Trellis coding;
- Constellation mapping;
- Constellation point scaling.

10.3.1 Tone ordering

During initialization, the receive PMD function shall calculate the numbers of bits and the relative gains to be used for every subcarrier in the MEDLEY set (either MEDLEY_{us} or MEDLEY_{ds}, depending on the transmission direction), as well as the order in which subcarriers are assigned bits (i.e., the tone ordering). The calculated bits and gains and the tone ordering shall be sent back to the transmit PMD function during the channel analysis and exchange phase of initialization (see clause 12.3.5.2). The number of subcarriers in MEDLEY_{us} and MEDLEY_{ds} is denoted by NSC_{us} and NSC_{ds} , respectively.

The pairs of bits and relative gains are defined, in ascending order of frequency or subcarrier index i , as a bit allocation table b and gain table g (i.e., b_i and g_i , for all subcarrier indices i that belong to the MEDLEY set). If trellis coding is used, the receive PMD function shall include an even number of 1-bit subcarriers ($NCONEBIT$) in the bit allocation table b .

The tone ordering table t is defined as the sequence $\{t_k\}$ in which subcarriers from the MEDLEY set are assigned bits from the input bitstream (t_k for $k = 1$ to NSC_{us} for the upstream tones, $k = 1$ to NSC_{ds} for the downstream tones) with constellation mapping beginning on the subcarrier with index $i = t_1$ and ending on the subcarrier with index $i = t_{NSC}$ (for example, $t_{75} = 160$ means that the subcarrier with index 160 is the 75th subcarrier to be assigned bits from the input bit stream). The tone ordering table t shall be created and exchanged during initialization (O-PMD, R-PMD messages, see clause 12.3.5.2) and shall remain unchanged until the next initialization.

If the ROC is enabled, the bits of buffer L_0 and buffer L_1 shall not share the same subcarrier. With trellis encoding, this means that all the bits u_1 to u_z that are used to encode a 4-dimensional symbol belong to the same buffer (see clause 10.3.2).

Following reception of the tables b , g and t , the transmit PMD function shall calculate a reordered bit table b' and a reordered tone table t' from the original tables b and t . Constellation mapping shall occur in sequence according to the reordered tone table t' , with the number of bits per subcarrier as defined by the original bit table b . Trellis coding shall occur according to the reordered bit table b' and reordered tone table t' .

If trellis coding is not used, $b' = b$ and $t' = t$.

If trellis coding is used, the reordering of table t shall be performed by the transmit PMD function. The reordered tone table t' shall be generated according to the following rules:

- Indices of all subcarriers supporting 0 bits or 2 or more bits appear first in t' , in the same order as in table t .
- Indices of all subcarriers supporting 1 bit appear last in table t' , in the same order as in table t .

If the bit allocation does not include any 1-bit subcarriers, the reordered tone table t' is identical to the original tone table t .

The (even number of) 1-bit subcarriers shall be paired to form 2-dimensional constellation points as input to the trellis encoder. The pairing shall be determined by the order in which the 1-bit subcarriers appear in the original tone ordering table t .

The table b' shall be generated by reordering the entries of table b according to the following rules:

- The first $NCONEBIT/2$ entries of b' shall be 0, where $NCONEBIT$ (by definition, even) is the number of subcarriers supporting 1 bit.
- The next entries of b' shall be 0, corresponding to all subcarriers that support 0 bits.
- The next entries of b' shall be non-zero, corresponding to the subcarriers that support two or more bits. The entries shall be determined using the new tone table t' in conjunction with the original bit table b .
- The last $NCONEBIT/2$ entries of b' correspond to the paired 1-bit constellations (i.e., 2 bits per entry).

The tables b' and t' shall be calculated from the original tables b and t as shown in the subcarrier pairing and bit reordering processes below.

```

/** CONSTRUCT THE TONE RE-ORDERING TABLE */
/*
Tone ordering table is denoted as array 't' and tone re-ordering
table is denoted as array 'tp'. The indices to these arrays are
denoted as 't_index' and 'tp_index', respectively.
*/
/*
Fill out tone re-ordering table with entries of tone ordering table
but skip 1-bit tones.
*/
tp_index = 1;
for (t_index = 1; t_index ≤ NSC; t_index++) {
    tone = t[t_index];
    bits = b[tone];
    if (bits != 1) {
        tp[tp_index++] = tone;
    }
}
/*
Add the 1-bit tones to the end of tone re-ordering table.
*/
for (t_index = 1; t_index ≤ NSC; t_index++) {
    tone = t[t_index];
    bits = b[tone];
    if (bits == 1) {
        tp[tp_index++] = tone;
    }
}
/* RE-ORDERING THE BIT ARRAY */
/*
The bit table is denoted as array 'b' and the ordered bit table is
denoted as array 'bp'.
The indexes to these arrays are denoted as 'b_index' and 'bp_index',
respectively.
*/
/* First, count the number of loaded tones and also 1-bit tones. */
NCONEBIT = 0; /* NCONEBIT is the number of subcarriers with 1 bit */
NCUSED = 0; /* NCUSED is the number of loaded subcarriers */
for (all i ∈ MEDLEY set) {
    if (b[i] > 0) {
        NCUSED++;
    }
}

```



```

    if (b[i] == 1) {
        NCONEBIT++;
    }
}
/* Fill initial zero entries for unloaded tones and half the number of
1-bit tones */
for (bp_index = 1; bp_index ≤ (NSC - (NCUSED - NCONEBIT/2));
    bp_index++) {
    bp[bp_index] = 0;
}
for (tp_index = 1; tp_index ≤ NSC; tp_index++) {
    tone = tp[tp_index];
    bits = b[tone];
    if (bits == 0) {
        /* skip unloaded tones */
    }
    if (bits == 1) {
        /* pair 2 consecutive 1-bit tones and add a
        single entry with 2 bits */
        bp[bp_index++] = 2;
        tp_index++;
    }
    if (bits > 1) {
        bp[bp_index++] = bits;
    }
}
}

```

Figure 10-3 presents an example to illustrate the tone reordering and bit reordering procedures, and the pairing of 1-bit subcarriers for trellis encoding.

Tone ordering table t (as determined by the receive PMD function, $NSC=23$)

7	14	21	4	11	18	1	8	15	22	5	12	19	2	9	16	23	6	13	20	3	10	17
---	----	----	---	----	----	---	---	----	----	---	----	----	---	---	----	----	---	----	----	---	----	----

Bit table b (as determined by the receive PMD function, 37 bits/symbol, natural order of sub-carrier indices starting from 1)

0	1	2	3	2	1	2	1	0	2	0	2	1	1	3	3	3	2	1	0	2	3	2
---	---	---	---	---	---	---	---	---	---	---	---	---	---	---	---	---	---	---	---	---	---	---

Tone reordered table t' (moving 1-bit sub-carriers to the end of the table)

7	21	4	11	18	1	15	22	5	12	9	16	23	20	3	10	17	14	8	19	2	6	13
---	----	---	----	----	---	----	----	---	----	---	----	----	----	---	----	----	----	---	----	---	---	----

Reordered bit table b' (moving 0-bit sub-carriers to the beginning of the table)

0	0	0	0	0	0	0	2	2	3	2	3	3	2	2	3	2	2	2	3	1+1	1+1	1+1
---	---	---	---	---	---	---	---	---	---	---	---	---	---	---	---	---	---	---	---	-----	-----	-----

Trellis pairs (encoding 25 data bits into 37 trellis bits) and bit mapping to sub-carriers

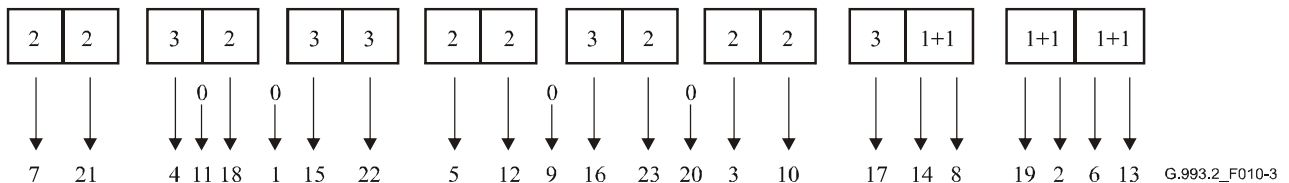

Figure 10-3 – Example of tone ordering and pairing of one-bit subcarriers

If on-line reconfiguration changes the number or indices of 0-bit subcarriers or 1-bit subcarriers, then tables t' and b' shall be recalculated from the updated table b and the original table t .

The symbol encoder takes L bits per symbol from the PMS-TC sublayer. If trellis coding is used, the L bits shall be encoded into a number of bits L' matching the bit allocation table b and the reordered bit allocation table b' , i.e., into a number of bits equal to $L' = \sum b'_i = \sum b_i$. The values of L and L' relate as:

$$L' = \sum b'_i = \sum b_i = L + \left\lceil \frac{NCUSED - \frac{NCONEBIT}{2}}{2} \right\rceil + 4$$

with the $\lceil x \rceil$ notation representing rounding to the next higher integer, and $NCUSED$ representing the number of subcarriers actually used for data transmission (with $b_i > 0$). The added 4 bits are to return the trellis to the zero state at the end of the DMT symbol, as described in clause 10.3.2.2.

The above relationship shows that using the 1-bit subcarrier pairing method, on average, one trellis overhead bit is added per set of four 1-bit subcarriers, i.e., one trellis overhead bit per 4-dimensional constellation.

In case trellis coding is not used, the value of L shall match the bit allocation table, i.e.,

$$L = \sum b_i$$

NOTE – A complementary tone reordering procedure should be performed in the receive PMD function. It is not necessary, however, to send the reordered bit table b' and the reordered tone table t' to the receive PMD function because they are generated in a deterministic way from the bit allocation table and tone ordering tables originally generated in the receive PMD function, and therefore the receive PMD function has all the information necessary to perform the constellation de-mapping and trellis decoding (if used).

10.3.2 Trellis encoder

The trellis encoder shall use block processing of Wei's 16-state 4-dimensional trellis code (see Figure 10-6) to improve system performance.

10.3.2.1 Bit extraction

Bits from the data frame buffer shall be extracted in sequential order according to the bit allocation table b' . The first bit of the data frame shall be extracted first. Because of the 4-dimensional nature of the code, the extraction is based on pairs of consecutive b' entries, rather than on individual ones, as in the non-trellis-coded case. Furthermore, due to the constellation expansion associated with coding, the bit allocation table, b' , specifies the number of coded bits per subcarrier, which can be any integer from 2 to 15.

Trellis coding shall be performed on pairs of consecutive b' values, starting with the first entry in the b' table. If the number of non-zero entries in the b' table is odd, the value b'_0 shall be prepended to the reordered bit table b' first to make an integer number of pairs and shall be set to ZERO. For subcarriers with 1-bit constellations, each (1+1)-bit b' entry will be mapped on two subcarriers, as described in Figure 10-3.

Given a pair (x, y) , $x + y - 1$ bits (reflecting a constellation expansion of 1 bit per 4 dimensions, or one half bit per subcarrier) are extracted from the data frame buffer, except for the last two 4-dimensional symbols. These $z = x + y - 1$ bits (t_z, t_{z-1}, \dots, t_1) are used to form the binary word u as shown in Table 10-1. Refer to clause 10.3.2.2 for the reason behind the special form of the word u for the case $x = 0, y > 1$.

Table 10-1 – Forming the binary word u

Condition	Binary word/comment
$x > 1, y > 1$	$u = (t_z, t_{z-1}, \dots, t_1)$
$x = 1, y \geq 1$	Condition not allowed
$x = 0, y > 1$	$u = (t_z, t_{z-1}, \dots, t_2, 0, t_1, 0)$
$x = 0, y = 0$	Bit extraction not necessary, no data bits being sent
$x = 0, y = 1$	Condition not allowed
NOTE – t_1 is the first bit extracted from the data frame buffer.	

The last two 4-dimensional symbols in each DMT symbol shall be chosen to force the convolutional encoder state to the zero state. For each of these symbols, the two LSBs of u are predetermined, and only $(x + y - 3)$ bits shall be extracted from the data frame buffer and shall be allocated to t_3, t_4, \dots, t_z .

NOTE – The above requirements imply a minimum size of the b' table of 4 non-zero entries. The minimum number of non-zero entries in the corresponding b table could be higher.

10.3.2.2 Bit conversion

The binary word $u = (u_{z'}, u_{z'-1}, \dots, u_1)$ extracted LSB first from the data frame buffer determines two binary words $v = (v_{z'-y}, \dots, v_0)$ and $w = (w_{y-1}, \dots, w_0)$, which are inserted LSB first in the encoded data bits buffer and used to look up constellation points in the constellation mapper (see Figure 10-4).

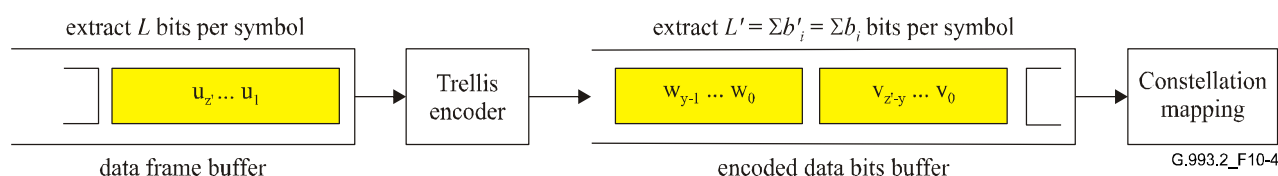

Figure 10-4 – Relationship of trellis encoder and constellation mapping

NOTE – For convenience of description, the constellation mapper identifies these x and y bits with a label whose binary representation is $(v_{b-1}, v_{b-2}, \dots, v_1, v_0)$. The same constellation mapping rules apply to both the v (with $b = x$) and the w (with $b = y$) vector generated by the trellis encoder.

For the usual case of $x > 1$ and $y > 1$, $z' = z = x + y - 1$, and v and w contain x and y bits respectively. For the special case of $x = 0$ and $y > 1$, $z' = z + 2 = y + 1$, $v = (v_1, v_0) = (0, 0)$ and $w = (w_{y-1}, \dots, w_0)$. The bits (u_3, u_2, u_1) determine (v_1, v_0) and (w_1, w_0) according to Figure 10-5.

The convolutional encoder shown in Figure 10-5 is a systematic encoder (i.e., u_1 and u_2 are passed through unchanged) as shown in Figure 10-6. The convolutional encoder state (S_3, S_2, S_1, S_0) is used to label the states of the trellis shown in Figure 10-8. At the beginning of a DMT symbol, the convolutional encoder state shall be initialized to $(0, 0, 0, 0)$.

The remaining bits of v and w are obtained from the less significant and more significant parts of $(u_{z'}, u_{z'-1}, \dots, u_4)$, respectively. When $x > 1$ and $y > 1$, $v = (u_{z'-y+2}, u_{z'-y+1}, \dots, u_4, v_1, v_0)$ and $w = (u_{z'}, u_{z'-1}, \dots, u_{z'-y+3}, w_1, w_0)$. When $x = 0$, the bit extraction and conversion algorithms result in $v_1 = v_0 = 0$. The binary word v shall be input first to the constellation mapper, and then the binary word w .

In order to force the final state of the convolutional encoder to the zero state $(0, 0, 0, 0)$, the two LSBs u_1 and u_2 of the final two 4-dimensional symbols in the DMT symbol are constrained to $u_1 = S_1 \oplus S_3$, and $u_2 = S_2$.

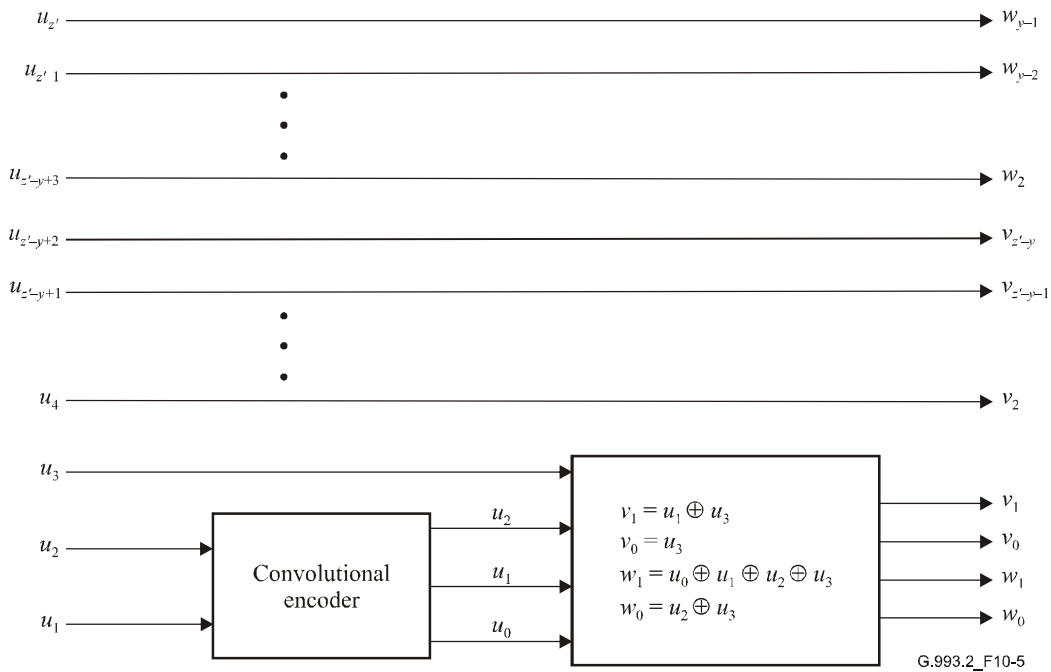

Figure 10-5 – Conversion of u to v and w

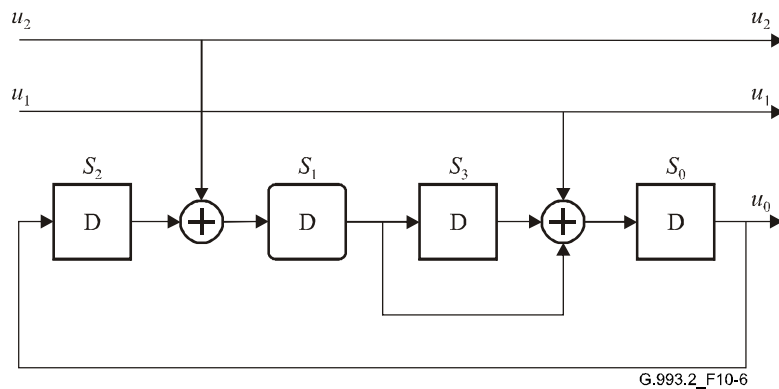

Figure 10-6 – Convolutional encoder: Finite state machine representation

10.3.2.3 Coset partitioning and trellis diagram

In a trellis code modulation system, the expanded constellation may be labelled and partitioned into subsets ("cosets") using a technique called mapping by set-partitioning. The 4-dimensional cosets in Wei's code can each be written as the union of two Cartesian products of two 2-dimensional cosets.

For example, $C_4^0 = (C_2^0 \times C_2^0) \cup (C_2^3 \times C_2^3)$. The four constituent 2-dimensional cosets, denoted by 0, 1, 2, and 3 for $C_2^0, C_2^1, C_2^2, C_2^3$, respectively, are shown in Figure 10-7.

The constellation mapping ensures that the two least significant bits of a constellation point comprise the index i of the 2-dimensional coset C_2^i in which the constellation point lies. The bits (v_1, v_0) and (w_1, w_0) are in fact the binary representations of this index.

The three bits (u_2, u_1, u_0) are used to select one of the eight possible 4-dimensional cosets. The eight cosets are labelled C_4^i where i is the integer with binary representation (u_2, u_1, u_0) . The additional bit u_3 (see Figure 10-5) determines which one of the two Cartesian products of 2-dimensional cosets is chosen from the 4-dimensional coset. The relationship is shown in Table 10-2. The bits (v_1, v_0) and (w_1, w_0) are computed from (u_3, u_2, u_1, u_0) using the linear equations given in Figure 10-5.

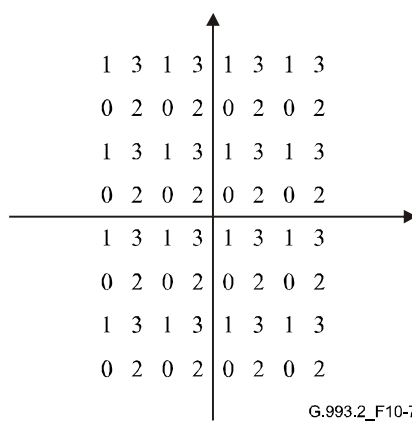

Figure 10-7 – Mapping of 2-dimensional cosets

Table 10-2 – Relation between 4-dimensional and 2-dimensional cosets

4-D coset	u_3	u_2	u_1	u_0	v_1	v_0	w_1	w_0	2-D cosets
C_4^0	0	0	0	0	0	0	0	0	$C_2^0 \times C_2^0$
	1	0	0	0	1	1	1	1	$C_2^3 \times C_2^3$
C_4^4	0	1	0	0	0	0	1	1	$C_2^0 \times C_2^3$
	1	1	0	0	1	1	0	0	$C_2^3 \times C_2^0$
C_4^2	0	0	1	0	1	0	1	0	$C_2^2 \times C_2^2$
	1	0	1	0	0	1	0	1	$C_2^1 \times C_2^1$
C_4^6	0	1	1	0	1	0	0	1	$C_2^2 \times C_2^1$
	1	1	1	0	0	1	1	0	$C_2^1 \times C_2^2$
C_4^1	0	0	0	1	0	0	1	0	$C_2^0 \times C_2^2$
	1	0	0	1	1	1	0	1	$C_2^3 \times C_2^1$
C_4^5	0	1	0	1	0	0	0	1	$C_2^0 \times C_2^1$
	1	1	0	1	1	1	1	0	$C_2^3 \times C_2^2$
C_4^3	0	0	1	1	1	0	0	0	$C_2^2 \times C_2^0$
	1	0	1	1	0	1	1	1	$C_2^1 \times C_2^3$
C_4^7	0	1	1	1	1	0	1	1	$C_2^2 \times C_2^3$
	1	1	1	1	0	1	0	0	$C_2^1 \times C_2^0$

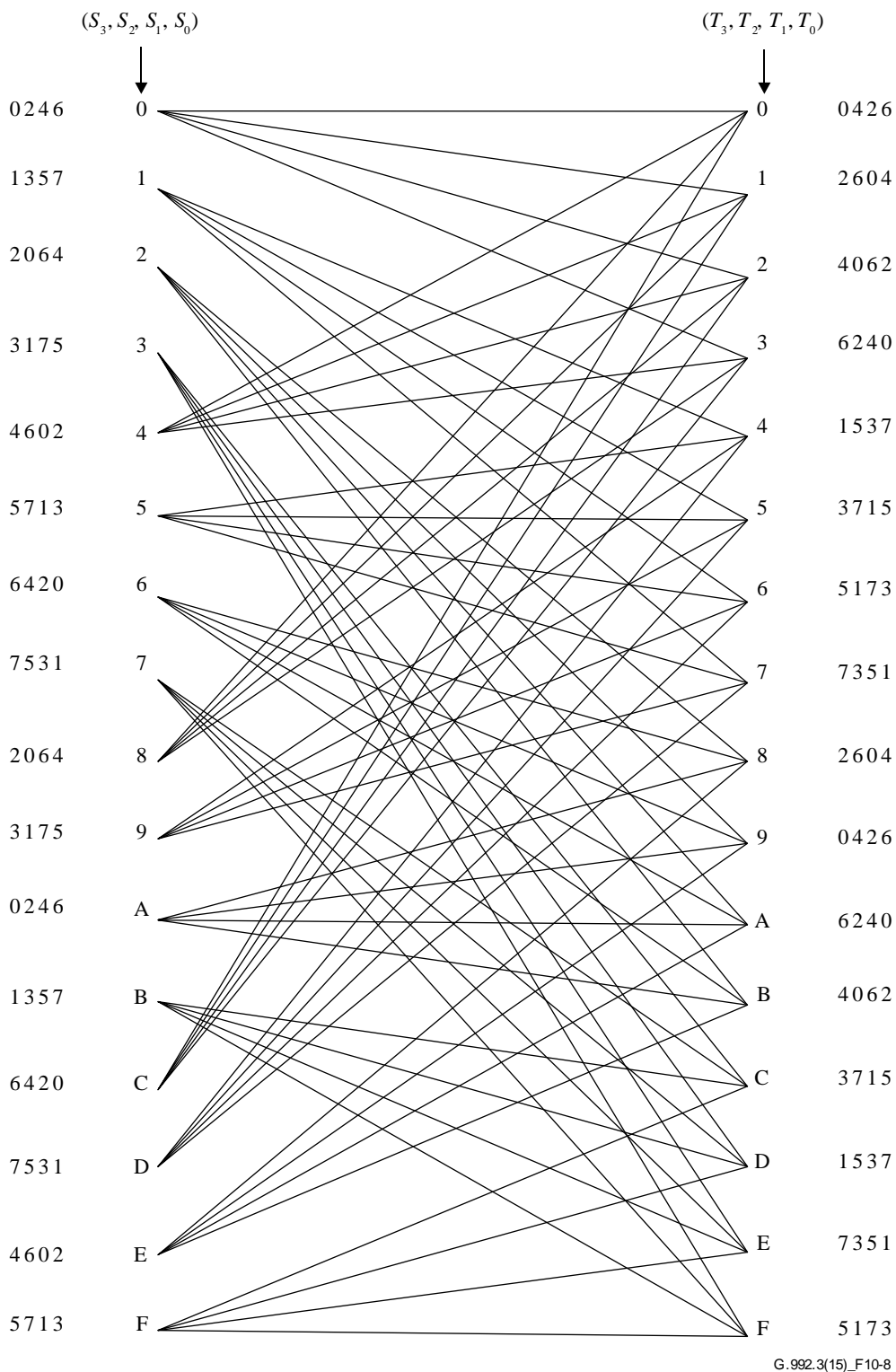

Figure 10-8 – Trellis diagram

Figure 10-8 shows the trellis diagram based on the finite state machine in Figure 10-6, and the one-to-one correspondence between (u_2, u_1, u_0) and the 4-dimensional cosets. In Figure 10-8, $S = (S_3, S_2, S_1, S_0)$ represents the current state, while $T = (T_3, T_2, T_1, T_0)$ represents the next state in the finite state machine. S is connected to T in the trellis diagram by a branch determined by the values of u_2 and u_1 . The branch is labelled with the 4-dimensional coset specified by the values of u_2, u_1 (and $u_0 = S_0$, see Figure 10-6). To make the trellis diagram more readable, the indices of the 4-dimensional coset labels are listed next to the starting and end points of the branches, rather than on the branches

themselves. The leftmost label corresponds to the uppermost branch for each state. The trellis diagram may be used when decoding the trellis code by the Viterbi algorithm.

10.3.3 Constellation mapper

The constellation mapper maps a set of bits to a constellation point. The data buffer contains $\sum_i b_i$ bits, which may or may not be trellis coded. Bits shall be extracted, as defined in clause 10.3.3.1, from the data buffer or from a PRBS generator. The extracted bits shall be mapped to constellation points as defined in clause 10.3.3.2.

10.3.3.1 Bit extraction

Bits shall be extracted from the data buffer or from a PRBS generator in the order defined by the tone ordering table.

For each subcarrier i in the MEDLEY set with $b_i > 0$ and $g_i > 0$ (linear scale), the encoder shall extract $b = b_i$ bits from the data buffer. The number of bits extracted (b_i) for each subcarrier is determined by the bit allocation table. The set of b extracted bits shall be represented as a binary word ($v_{b-1} v_{b-2} \dots v_1 v_0$), where the first bit extracted shall be v_0 , the LSB. The encoder shall select a point (X, Y) from the constellation based on the b -bit word ($v_{b-1} v_{b-2} \dots v_1 v_0$).

For each monitored subcarrier (i.e., subcarriers in the MEDLEY set with $b_i = 0$ and $g_i > 0$) and for each subcarrier used as a pilot tone during showtime (see clause 12.3.5.2.2.4), no bits shall be extracted from the data buffer. Instead, the encoder shall extract $b = 2$ bits ($v_1 v_0$) from the PRBS generator, where the first bit extracted shall be v_0 . For the pilot tone subcarrier(s), the bits extracted from the PRBS generator shall be overwritten by the modulator with a fixed 4-QAM constellation point corresponding to the bits 00 (i.e., the two bits from the PRBS generator are effectively ignored).

The PRBS generator shall be defined by:

$$d_n = 1 \text{ for } n = 1 \text{ to } n = 23; \text{ and}$$

$$d_n = d_{n-18} \oplus d_{n-23} \text{ for } n > 23.$$

The PRBS generator shall be reset at the beginning of showtime. Upon reset of the PRBS, d_1 shall be the first bit extracted, followed by d_2, d_3 , etc. For each data symbol, the number of bits extracted from the PRBS generator shall be twice the number of subcarriers in the MEDLEY set that have $b_i = 0$ plus twice the number of showtime pilot tones. No bits shall be extracted from the PRBS generator during sync symbols.

For a given subcarrier i not in the MEDLEY set ($b_i = 0$ by definition), no bits shall be extracted from the data buffer and no bits shall be extracted from the PRBS generator. Instead, the constellation mapper may select a vendor-discretionary (X, Y) point (which may change from symbol to symbol and which does not necessarily coincide with a constellation point).

The described bit extraction mechanism is relevant only during showtime.

10.3.3.2 Constellations

An algorithmic constellation mapper shall be used to construct subcarrier QAM constellations with a minimum number of bits equal to 1 and a maximum number of bits equal to 15.

The constellation points are denoted (X, Y). X and Y shall lie at the odd integers $\pm 1, \pm 3, \pm 5$, etc. For convenience of illustration, each constellation point in Figures 10-9 through 10-13 is labelled by an integer whose unsigned binary representation is ($v_{b-1} v_{b-2} \dots v_1 v_0$).

10.3.3.2.1 Even values of b

For even values of b , the integer values X and Y of the constellation point (X, Y) shall be determined from the b bits $(v_{b-1}, v_{b-2}, \dots, v_1, v_0)$ as follows. X and Y shall be odd integers with two's-complement binary representations $(v_{b-1} v_{b-3} \dots v_1 1)$ and $(v_{b-2} v_{b-4} \dots v_0 1)$, respectively. The MSBs, v_{b-1} and v_{b-2} , shall be the sign bits for X and Y , respectively. Figure 10-9 shows example constellations for $b = 2$ and $b = 4$.

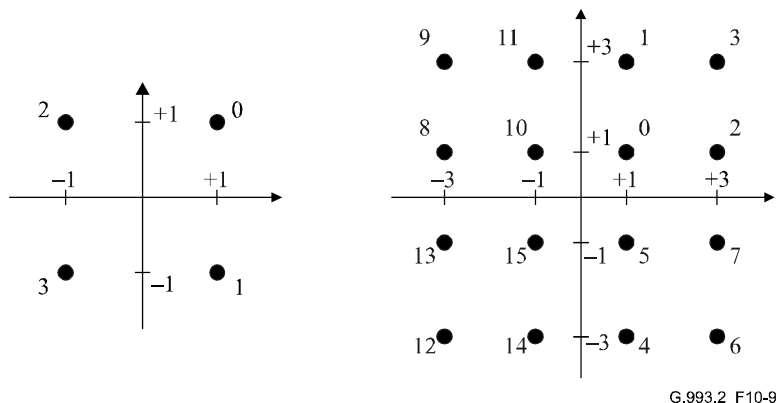

Figure 10-9 – Constellation labels for $b = 2$ and $b = 4$

NOTE – The 4-bit constellation may be obtained from the 2-bit constellation by replacing each label n by the 2×2 block of labels:

$$\begin{array}{cc} 4n+1 & 4n+3 \\ 4n & 4n+2 \end{array}$$

The same procedure may be used to construct the larger even-bit constellations recursively. The constellations obtained for even values of b are square in shape.

10.3.3.2.2 Odd values of b

10.3.3.2.2.1 $b = 1$

Figure 10-10 shows the constellation for the case $b = 1$.

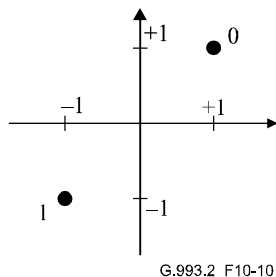

Figure 10-10 – Constellation labels for $b = 1$

When trellis coding is used, the 2-bit words generated by the trellis encoder shall be mapped on two 1-bit subcarriers using the same labelling for 1-bit and 2-bit constellations as described above. An example for $v_0 = 1$ and $v_1 = 0$ is shown in Figure 10-11, in which the constellation for the 2-bit word is on the right-hand side of the diagram.

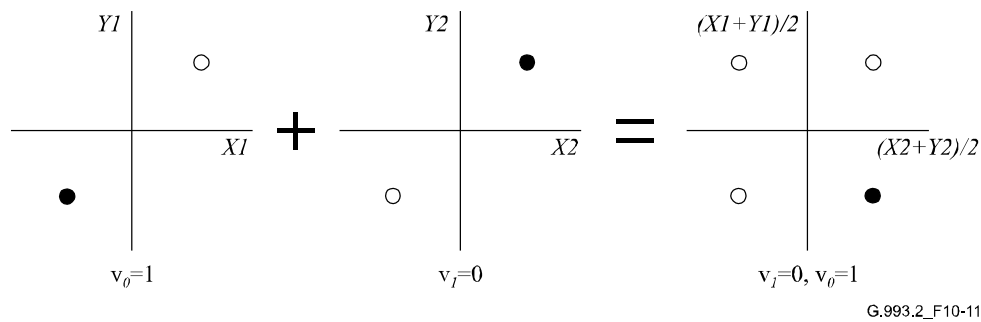

Figure 10-11 – Combination of a pair of 1-bit constellations to build a 2-bit constellation

10.3.3.2.2.2 $b = 3$

Figure 10-12 shows the constellation for the case $b = 3$.

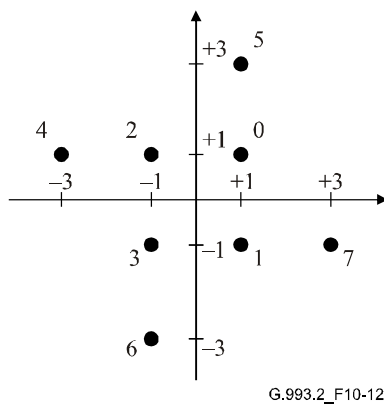

Figure 10-12 – Constellation labels for $b = 3$

10.3.3.2.2.3 $b > 3$

If b is odd and greater than 3, the two MSBs of X and the two MSBs of Y shall be determined by the five MSBs of the b bits ($v_{b-1} v_{b-2} \dots v_1 v_0$). Let $c = (b+1)/2$, then X and Y shall have the two-complement binary representations ($X_c X_{c-1} v_{b-4} v_{b-6} \dots v_3 v_1 1$) and ($Y_c Y_{c-1} v_{b-5} v_{b-7} v_{b-9} \dots v_2 v_0 1$), where X_c and Y_c are the sign bits of X and Y respectively. The relationship between X_c , X_{c-1} , Y_c , Y_{c-1} , and ($v_{b-1} v_{b-2} \dots v_{b-5}$) shall be as shown in Table 10-3.

Table 10-3 – Determining the top two bits of X and Y

$v_{b-1} v_{b-2} \dots v_{b-5}$	$X_c X_{c-1}$	$Y_c Y_{c-1}$	$v_{b-1} v_{b-2} \dots v_{b-5}$	$X_c X_{c-1}$	$Y_c Y_{c-1}$
00000	00	00	10000	01	00
00001	00	00	10001	01	00
00010	00	00	10010	10	00
00011	00	00	10011	10	00
00100	00	11	10100	00	01
00101	00	11	10101	00	10
00110	00	11	10110	00	01
00111	00	11	10111	00	10
01000	11	00	11000	11	01
01001	11	00	11001	11	10

Table 10-3 – Determining the top two bits of X and Y

$v_{b-1} v_{b-2} \dots v_{b-5}$	$X_c X_{c-1}$	$Y_c Y_{c-1}$	$v_{b-1} v_{b-2} \dots v_{b-5}$	$X_c X_{c-1}$	$Y_c Y_{c-1}$
0 1 0 1 0	1 1	0 0	1 1 0 1 0	1 1	0 1
0 1 0 1 1	1 1	0 0	1 1 0 1 1	1 1	1 0
0 1 1 0 0	1 1	1 1	1 1 1 0 0	0 1	1 1
0 1 1 0 1	1 1	1 1	1 1 1 0 1	0 1	1 1
0 1 1 1 0	1 1	1 1	1 1 1 1 0	1 0	1 1
0 1 1 1 1	1 1	1 1	1 1 1 1 1	1 0	1 1

Figure 10-13 shows the constellation for the case $b = 5$.

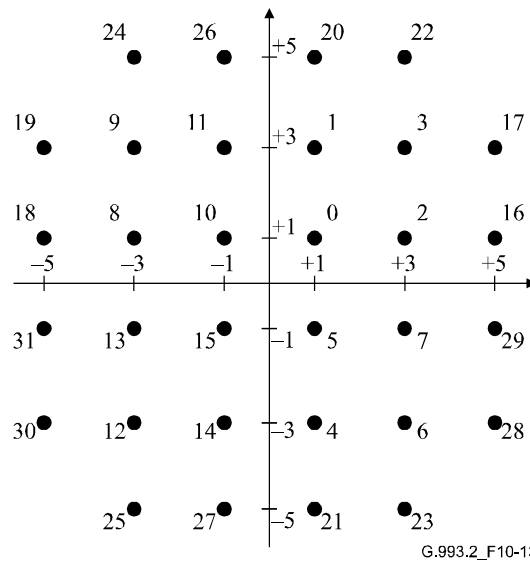

Figure 10-13 – Constellation labels for $b = 5$

NOTE – The 7-bit constellation may be obtained from the 5-bit constellation by replacing each label n by the 2×2 block of labels:

$$\begin{array}{cc} 4n+1 & 4n+3 \\ 4n & 4n+2 \end{array}$$

The same procedure may then be used to construct the larger odd-bit constellations recursively.

10.3.4 Constellation point scaling

Constellation points shall be scaled to normalize their average power, to achieve a frequency-dependent transmit PSD, and to equalize the SNR margin over the subcarriers in use.

The scaling required to normalize the average power is dependent only on the size of the constellation. It is represented by $\chi(b_i)$ and is specified in clause 10.3.4.1.

The gain adjuster g_i is used to equalize the SNR margin over the subcarriers in use and is specified in clause 10.3.4.2.

The PSD shaping mechanism is based on tss_i coefficients and is specified in clause 10.3.4.3. The shaping by a tss_i value is in addition to any shaping introduced by time-domain filters (if used).

For subcarriers in the MEDLEY set, each constellation point (X_i, Y_i) , corresponding to the complex value $X_i + jY_i$ at the output of the constellation mapper, shall be scaled by the power-normalization factor $\chi(b_i)$, the gain adjuster g_i , and a frequency-domain spectrum shaping coefficient tss_i to result in a complex number Z_i , defined as:

$$Z_i = g_i \times tss_i \times \chi(b_i) \times (X_i + jY_i)$$

10.3.4.1 Power normalization

The values (X, Y) shall be scaled such that all constellations, regardless of size, have the same average power. The required scaling, $\chi(b_i)$, is a function only of the constellation size.

10.3.4.2 The gain adjuster

The gain g_i is intended for fine gain adjustment within a range from approximately 0.1888 to 1.33, which may be used to equalize the SNR margin for all subcarriers. The g_i values in dB shall be defined as the $20 \times \log_{10}(g_i)$, thus g_i values of 0.1888 and 1.33 in linear scale correspond to g_i values of -14.5 dB and of $+2.5$ dB, respectively. The values of g_i for all MEDLEY subcarriers shall be assigned during initialization, as described in clause 12.3.5 and stored in the bits-and-gains table specified in clause 10.3.1 (b_i and g_i values). The g_i values may also be updated during showtime via an OLR procedure described in clauses 13 and 11.2.3.3.

The g_i settings (in the bits-and-gains table) shall comply with the following requirements:

- If $b_i > 0$, then g_i shall be in the $[-14.5$ to $+2.5]$ (dB) range.
- If $b_i > 0$, then the linear average of the g_i^2 's in any band (as specified during the ITU-T G.994.1 handshake phase of initialization, see clause 12.3.2) shall be ≤ 1 .
- If $b_i = 0$, then g_i shall be equal to 0 (linear) or in the $[-14.5$ to $0]$ (dB) range.
- The gain adjustments shall be set in accordance with service priorities specified in clause 12.3.7.

For subcarriers not in the MEDLEY set, see Table 10-4.

10.3.4.2.1 Nominal aggregate transmit power (NOMATP)

The nominal aggregate transmit power (NOMATP) shall be computed by the following equation:

$$\text{NOMATP} = 10\log_{10} \Delta f + 10\log_{10} \left(\sum_{i \in \text{MEDLEYset}} \left(10^{\frac{\text{MREFPSD}[i]}{10}} g_i^2 \right) \right)$$

where $\text{MREFPSD}[i]$ and g_i are, respectively, the values of MREFPSD in dBm/Hz and gain (linear scale) for subcarrier i from the MEDLEY set (see clause 12.3.3.2.1.3), and Δf is the subcarrier spacing in Hz.

The downstream NOMATP (NOMATPds) shall be computed for subcarriers from the downstream MEDLEY set (MEDLEYds). The upstream NOMATP (NOMATPus) shall be computed for subcarriers from the upstream MEDLEY set (MEDLEYus).

The maximum nominal aggregate transmit power during initialization and showtime (parameter MAXNOMATP) is defined by the CO-MIB as specified in [ITU-T G.997.1]. The MAXNOMATP settings in the CO-MIB for the downstream (MAXNOMATPds) and for the upstream (MAXNOMATPus) shall not exceed, respectively, the maximum downstream and upstream aggregate transmit power specified in Table 6-1.

The g_i settings at the VTU-O and VTU-R shall be such that the values of NOMATPds and NOMATPus do not exceed, respectively, the CO-MIB parameter MAXNOMATPds and MAXNOMATPus. To assist the proper gain setting at the VTU-O, the MAXNOMATPds is communicated from the VTU-O to the VTU-R during the channel discovery phase.

10.3.4.3 Frequency-domain transmit spectrum shaping (tss_i)

The tss_i are intended for frequency-domain spectrum shaping, both upstream and downstream. The tss_i values are vendor discretionary and shall be in the range between 0 and 1 (linear) in steps of $\frac{1}{1024}$. The tss_i values shall be set such that the highest tss_i value across all subcarriers is 1. Smaller values of tss_i provide attenuation, and the value $tss_i = 0$ corresponds to no power transmitted on the particular subcarrier. If no frequency-domain spectrum shaping is applied, the tss_i values shall be equal to 1 for all subcarriers.

The tss_i values in dB (\log_{tss_i}) are defined as $20 \times \log_{10}(tss_i)$ and shall be converted to linear values of tss_i using the equation:

$$tss_i = \frac{\text{Round}\left(1024 \times 10^{\frac{\log_{tss_i}}{20}}\right)}{1024}$$

The values of tss_i for the given direction of transmission shall be determined by the transmitting VTU, and shall be defined as a set of breakpoints $\{(i_1, \log_{tss_{i1}}) \dots, (i_n, \log_{tss_{in}})\}$, where i is the subcarrier index. This set shall be communicated to the receiving VTU during the channel discovery phase of the initialization using O-PRM and R-PRM messages, as described in clause 12.3.3.2. Both transmitting and receiving VTUs shall derive the tss_i values for subcarriers between the breakpoints using linear interpolation of the defined \log_{tss_i} values over the linear scale of subcarrier indexes. The receiving VTU shall assign tss_i values equal to tss_{i_n} for $i > i_n$, and equal to tss_{i_1} for $i < i_1$.

The obtained values of tss_i are relevant only for subcarriers that are actually transmitted. The receiver shall ignore the tss_i values that are either received or obtained by interpolation for the subcarriers that are not used for transmission ($Z_i=0$, see Table 10-4).

The combined accuracy of the linear interpolation of \log_{tss_i} values and of the conversion to linear tss_i values shall be less than one half LSB for the 10-bit representation format of the linear tss_i values. No error shall be introduced when \log_{tss_i} equals 0 dB or is interpolated between \log_{tss_i} values that equal 0 dB.

The transmitters of the VTU-O and VTU-R, respectively, shall set the tss_i values such that, prior to the gain adjustment (i.e., assuming $g_i=1$), the PSD of the transmit signal as measured in the reference impedance at the U interface, from the start of the training phase and for the remainder of initialization, shall not deviate from the values of MREFPSDs and MREFPSD_{us}, communicated in O-PRM and R-PRM, respectively, by more than 1 dB (parameter "MEDLEY reference PSD", see clause 12.3.3.2). Thus, tss_i settings shall take into consideration any additional spectrum shaping caused by time-domain filters and analog filters included in the transmission path between the output of the modulator and U interface.

10.3.4.4 Summary of subcarrier constellation mapping and constellation point scaling

Table 10-4 summarizes the subcarrier constellation mapping and constellation point scaling requirements for the stages of initialization and during showtime.

Table 10-4 – Summary of subcarrier modulation in initialization and showtime

Phase	Subcarrier index (i)	Z_i
Channel discovery (12.3.3)	$i \in \text{SUPPORTEDCARRIERS}$	$tss_i \times (X_i + jY_i)$
	$i \notin \text{SUPPORTEDCARRIERS}$	0
	$i \in \text{MEDLEY}$	$tss_i \times (X_i + jY_i)$

Table 10-4 – Summary of subcarrier modulation in initialization and showtime

Phase	Subcarrier index (i)		Z_i
Training (12.3.4)	$i \notin \text{MEDLEY}$ (Note 1)		0
Channel analysis and exchange (12.3.5)	$i \in \text{MEDLEY}$		$tss_i \times (X_i + jY_i)$
	$i \notin \text{MEDLEY}$		0
Showtime	$i \in \text{MEDLEY}$	$b_i > 0, g_i > 0$	$g_i \times tss_i \times \chi(b_i) \times (X_i + jY_i)$
		Monitored subcarriers ($b_i = 0, g_i > 0$, modulated by 4-QAM)	$g_i \times tss_i \times \chi(b = 2) \times (X_i + Y_i)$
		Pilot tones ($b_i = 0, g_i > 0$, modulated by 4-QAM)	$g_i \times tss_i \times \chi(b = 2) \times (X_i + Y_i)$
		Others with $b_i = 0, g_i = 0$	0
	$i \notin \text{MEDLEY}$	$i \in \text{SUPPORTEDCARRIERS}$, and $i \in \text{BLACKOUT}$	0
		$i \in \text{SUPPORTEDCARRIERS}$, and $i \notin \text{BLACKOUT}$	Vendor discretionary (Note 2)
		$i \notin \text{SUPPORTEDCARRIERS}$	0
NOTE 1 – The O-P-TEQ and R-P-TEQ signals used during the training phase include subcarriers that are outside the MEDLEY set. See clause 12.3.4.3 for details.			
NOTE 2 – The PSD of vendor-discretionary signals on these subcarriers shall be below MREFMASK by 10 dB.			

10.4 Modulation

10.4.1 Data subcarriers

The subcarriers shall be indexed from $i = 0$ to $i = MSI$, where MSI is the index of the highest loaded subcarrier (i.e., the maximum index in the MEDLEY set). The values of MSI may be different for upstream and downstream transmission and are denoted as MSI_{us} and MSI_{ds} respectively. The index of the highest loaded subcarrier (MSI_{us} or MSI_{ds}) will be restricted by the selected profile and band plan as shown in Table 6-1. Specifically, MSI_{us} shall be equal to or lower than the "index of the highest supported upstream data-bearing subcarrier" (6.2.10) and MSI_{ds} shall be equal to or lower than the "index of the highest supported downstream data-bearing subcarrier" (6.2.9). Transmission will take place on NSC subcarriers, with $NSC_{us} \leq MSI_{us}$ and $NSC_{ds} \leq MSI_{ds}$; the subcarrier with index $i=0$ shall not be used. $NSC_{us} + NSC_{ds}$ shall always be less than 4096.

The subcarriers to be used for data transport in the upstream and downstream directions (MEDLEY_{us} and MEDLEY_{ds} sets, respectively) shall be determined during initialization, as specified in clause 12.3.3.

NOTE – The subcarriers used for data transmission depend on channel characteristics, such as loop attenuation and noise, and on the specific requirements on the PSD of the transmit signal, such as notching of amateur radio bands, PSD reduction at low frequencies to share the loop with POTS or ISDN, and others.

10.4.2 Subcarrier spacing

Subcarrier spacing is the frequency spacing, Δf , between the subcarriers. The subcarriers shall be centered at frequencies $f = i \times \Delta f$. The subcarrier index i takes the values $i = 0, 1, 2, \dots, MSI$. Valid values of subcarrier spacing are 4.3125 kHz and 8.625 kHz, both with a tolerance of ± 50 ppm.

Subcarrier spacing is profile dependent (see Table 6-1).

10.4.3 Modulation by the inverse discrete Fourier transform (IDFT)

The IDFT is used to modulate the output of the symbol encoder onto the DMT subcarriers. It converts the NSC complex values Z_i (as defined in clause 10.3.4) generated by the symbol encoder (frequency domain representation) into $2N$ real values x_n ($n = 0, 1, \dots, 2N - 1$), which is a time domain representation. The conversion shall be performed with a $2N$ point IDFT, with $N - 1 \geq MSI$, as:

$$x_n = \sum_{i=0}^{2N-1} \exp\left(j \cdot 2 \cdot \pi \cdot \frac{n \cdot i}{2 \cdot N}\right) \cdot Z_i \quad \text{for } n = 0 \text{ to } 2N - 1$$

The valid values of N are $N = 2^{n+5}$, where n can take integer values from 0 to 7. The values of N used for upstream and downstream are exchanged during initialization (see clauses 12.3.2, 12.3.3.2.1.3, and 12.3.3.2.2.3).

For subcarrier indices i that are not in the MEDLEY set and for $MSI < i < N$, the corresponding values of Z_i are not generated by the symbol encoder. These values are vendor discretionary, but shall comply with the constraints given in Table 10-4. Z_0 shall always be equal to zero and Z_N shall always be a real value.

In order to generate real values of x_n , the input values Z_i , where $i = 0, 1, \dots, N - 1$ and $Z_0 = 0$, shall be further augmented so that the vector Z_i has a Hermitian symmetry:

$$Z_i = \text{conj}(Z_{2N-i}) \quad \text{for } i = N + 1 \text{ to } 2N - 1$$

NOTE – Different values of N result in different transmit signal images above the Nyquist frequency. Knowledge of how the additional Z_i values are defined allows the receiver to better estimate the channel during initialization.

10.4.4 Cyclic extension and windowing

The transmit DMT symbol shall be constructed from the IDFT samples x_n using the following rules.

The last L_{CP} samples of the IDFT output x_n shall be prepended to the $2N$ output IDFT samples x_n as the cyclic prefix (CP). The first L_{CS} samples of x_n shall be appended to the block of $x_n + L_{CP}$ samples as the cyclic suffix (CS). The first β samples of the cyclic prefix and last β samples of the cyclic suffix shall be used for shaping the envelope of the transmitted signal (windowing). The values of the window samples are vendor discretionary. The maximum value of β shall be $\min(N/16, 255)$. The windowed parts (β samples) of consecutive symbols shall overlap and be added to one another.

Figure 10-14 summarizes all of the operations that shall be performed by the transmitter to construct the DMT symbol.

The cyclic extension (CE) length is defined as $L_{CE} = L_{CP} + L_{CS} - \beta$. The values L_{CP} , L_{CS} and β shall be set in order to satisfy the equation $L_{CE} = (L_{CP} + L_{CS} - \beta) = m \times N/32$, where valid values of m are integers between 2 and 16, inclusive. Support for the value of $m = 5$ is mandatory. In all cases, the following relations shall hold: $\beta < L_{CP}$ and $\beta < L_{CS}$.

NOTE – Partitioning between the CS and CP is vendor discretionary. The specific settings of the CE and CP are exchanged during initialization.

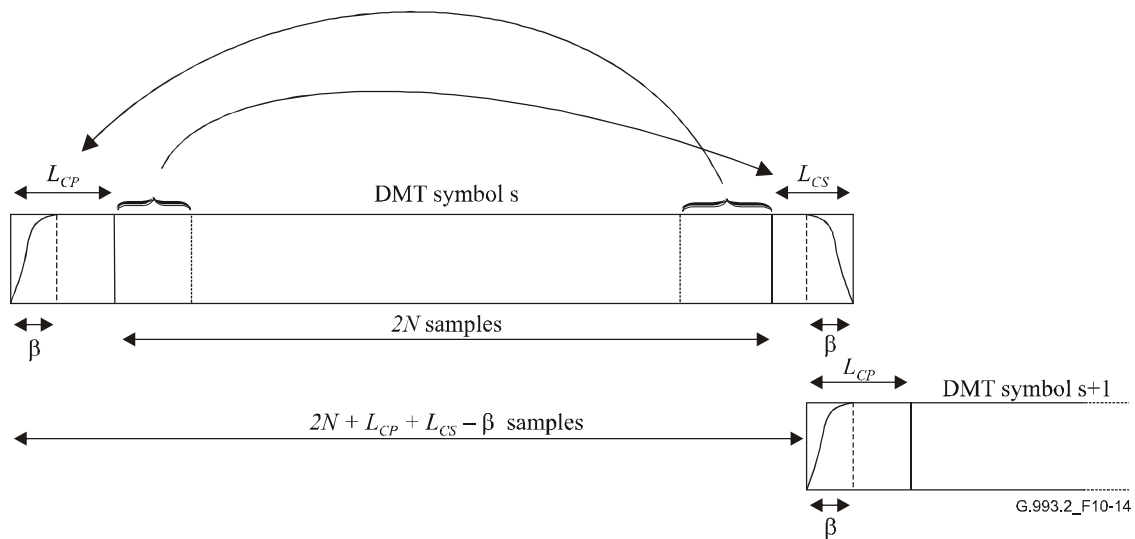

Figure 10-14 – Cyclic extension, windowing and overlap of DMT symbols

For a given setting of the CE length and window length β , the DMT symbols will be transmitted at a symbol rate equal to:

$$f_{DMT} = \frac{2N \times \Delta f}{2N + L_{CP} + L_{CS} - \beta} = \frac{2N \times \Delta f}{2N + L_{CE}}$$

If the CE length corresponds to $m = 5$, this results in symbol rates of 4 ksymbols/s for $\Delta f = 4.3125$ kHz and 8 ksymbols/s for $\Delta f = 8.625$ kHz, independent of the sampling rate used.

The data symbol rate is equal to:

$$f_s = \frac{2N \times \Delta f}{2N + L_{CP} + L_{CS} - \beta} \times \frac{256}{257}$$

The equivalent 4k DMT symbol length (denoted as T_{4k}) is defined as:

$$T_{4k} = \frac{1}{f_{DMT}} \quad \text{for } \Delta f = 4.3125 \text{ kHz, and}$$

$$T_{4k} = \frac{2}{f_{DMT}} \quad \text{for } \Delta f = 8.625 \text{ kHz.}$$

If the CE length corresponds to $m = 5$, this results in an equivalent 4k DMT symbol length of 250 μ s, independent of the subcarrier spacing and sampling rate used.

10.4.5 Synchronization

10.4.5.1 Pilot tones

The VTU-R may select one or more subcarriers to use for timing recovery, called "pilot tones". Pilot tones are selected separately for initialization and showtime.

Pilot tones during initialization: The VTU-R may select initialization pilot tones by indicating its selection of pilot tones in R-MSG 1 (see clause 12.3.3.2.2.1). Initialization pilot tones are used for initialization signals O-P-PILOT1, O-P-PILOT2, O-P-PILOT3 and O-P-ECT as specified in clauses 12.3.3 and 12.3.4. The total number of initialization pilot tones shall not exceed 16.

Pilot tones during showtime: The VTU-R may select showtime pilot tones by indicating its selection of pilot tones in R-PMD (see clause 12.3.5.2.2.4). The VTU-O shall transmit on the selected

subcarriers the value of 00 using 4-QAM modulation during every data symbol of showtime. The constellation point scaling for the pilot tone(s) shall follow the same rules as for data carrying subcarriers described in clause 10.3.4. The total number of pilot tones shall not exceed 16. Pilot tones are not transmitted on sync symbols (see clause 10.5.1).

10.4.5.2 VTU-R timing

The VTU-R shall perform loop timing (see clause 3.30).

10.4.5.3 Timing advance

The VTU-R shall be capable of implementing a timing offset between transmit and receive DMT symbols, called timing advance (TA). It shall set the TX symbol TA reference point prior to the RX symbol TA reference point by the value of TA, see Figure 10-15. For the purpose of implementing TA, the TX symbol TA reference point is $\text{floor}(\beta_{us}/2)$ samples after the first sample of the cyclic prefix. Similarly, for the purpose of implementing TA, the RX symbol TA reference point is $\text{floor}(\beta_{ds}/2)$ samples after the estimated first sample of the cyclic prefix. The estimation of the first sample of the received symbol is vendor discretionary and may depend on loop conditions. However, the VTU-R should make its best effort to meet the TA at the U interface. The TA shall be calculated and set during initialization, as specified in clauses 12.3.3 and 12.3.4.

If the value of TA is exactly equal to the propagation delay from the VTU-O to the VTU-R, it will force the VTU-O and VTU-R to start transmission of DMT symbols in opposite directions simultaneously (i.e., the DMT symbols in the downstream and upstream transmission directions start at the same absolute time). This results in orthogonality between transmitted and received DMT symbols when the minimum value of CE length is used.

NOTE – To obtain the desired orthogonality between transmit and receive signals with the minimum value of CE length, the value of TA should apply at the U interface.

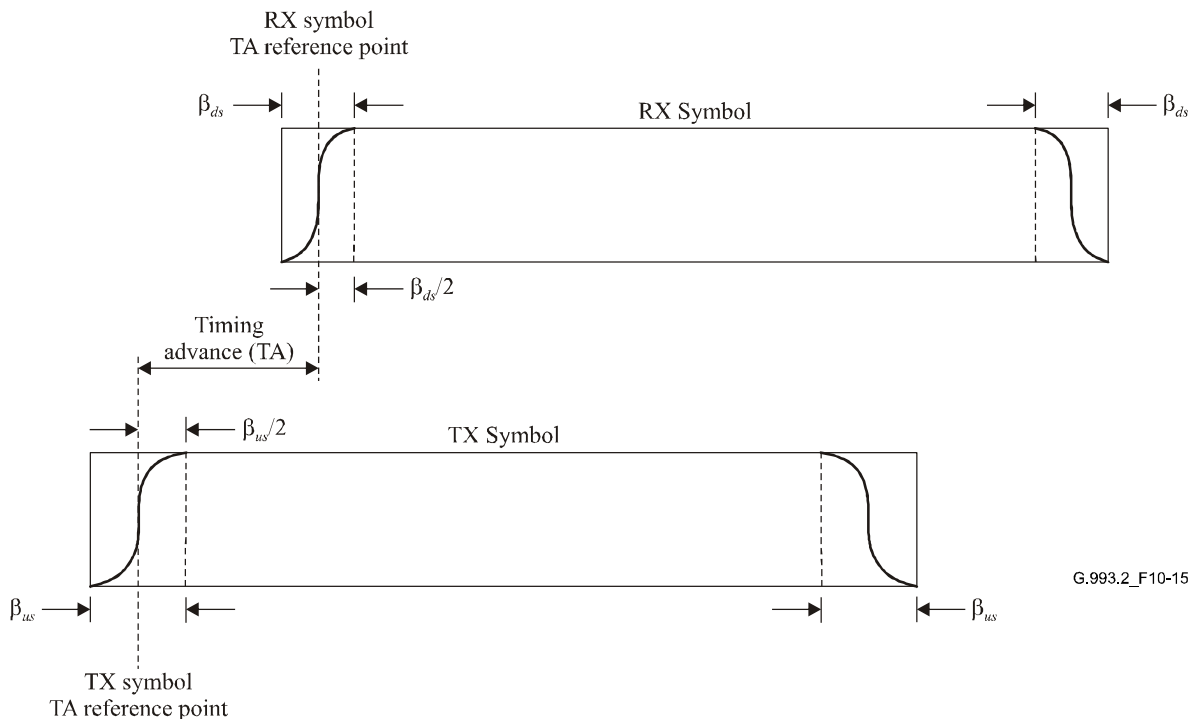

Figure 10-15 – Illustration of TA (VTU-R)

10.4.5.4 Synchronous mode

Support of synchronous mode is optional. In synchronous mode, the out-of-band near-end crosstalk (NEXT) generated by the VDSL2 systems operating in synchronous mode will be nearly orthogonal

to the VDSL2 signals received by other VTUs operating in synchronous mode. Therefore, the NEXT will not significantly degrade the SNR on other lines in synchronous mode.

In synchronous mode, all VTU-Os shall use the same subcarrier spacing and symbol rate, and shall start transmission of DMT symbols at the same time on all of the lines in the synchronized group. The transmit symbol clocks shall be phase-synchronous at all VTU-Os with a 1 μ s maximum phase error tolerance.

In synchronous mode all VTUs shall use the same value of CE length (see clause 10.4.4). The CE length used for all lines in the synchronized group should have values appropriate for the line in the group that has the largest propagation delay.

10.5 Symbol encoder for sync symbol

10.5.1 Constellation mapper for sync symbol

Each MEDLEY subcarrier of the sync symbol in either transmission direction (MEDLEYds or MEDLEYus; see clauses 12.3.3.2.1.3 and 12.3.3.2.2.3) shall be modulated by two bits from the sync frame (which will be either 00 or 11 for all MEDLEY subcarriers) using the 4-QAM constellation defined in clause 10.3.3.2.1. The constellation points on these subcarriers shall then be rotated based on the 2-bit number provided by the quadrant scrambler described in clause 12.3.6.2. The scrambler shall be used in reset mode (see clause 12.3.6.2.1).

Pilot tones (as specified in clause 10.4.5.1) are not transmitted on sync symbols.

NOTE – The first five and last five symbols of initialization signals O-P-SYNCHRO and R-P-SYNCHRO are identical to a sync symbol modulating a sync frame of all ONES. The middle five symbols of O-P-SYNCHRO and R-P-SYNCHRO are identical to a sync symbol modulating a sync frame of all ZEROS.

An inversion of the bits in the sync frame (i.e., from all ONES to all ZEROS and vice versa) shall be used to signal on-line reconfiguration timing during showtime, as described in clause 10.5.3.

For the subcarriers in the SUPPORTEDCARRIERS set that are not in the MEDLEY set and are not in the BLACKOUT set, the constellation mapper may select a vendor-discretionary (X, Y) point, which may also change from one sync symbol to another (see Table 10-4).

10.5.2 Constellation point scaling for sync symbol

The $\chi(b_i)$, g_i and tss_i values shall be applied to the sync symbol in the same way as they are applied to data symbols in showtime (see clause 10.3.4).

10.5.3 On-line reconfiguration

The transmitter inserts a sync symbol every 257 symbols, as defined in clause 10.2. Therefore, a sync symbol shall be transmitted after every 256 data symbols.

To signal on-line reconfiguration timing (see clause 13.3), the responding VTU shall send a Syncflag (see clause 3.64).

After the transmission of a Syncflag, the sync frame modulated onto subsequent sync symbols shall remain the same (i.e., either all ONES or all ZEROS) until timing for the next on-line reconfiguration needs to be signalled.

At the beginning of showtime, the first sync symbol transmitted shall be modulated by a sync frame of all ones.

10.6 Symbol encoder for initialization

Encoding of DMT symbols transmitted during the different phases of initialization is specified in clauses 12.3.3.3, 12.3.4.3, and 12.3.5.3. The values of X and Y of the 4-QAM constellation points during initialization shall be as shown in the constellation diagram of Figure 10-9. These values shall be scaled such that at the output of the constellation mapper the constellation represents the rms

energy of a subcarrier transmitted at the relevant PSD level. The applicable PSD levels are specified in clauses 12.3.3.3, 12.3.4.3 and 12.3.5.3.

11 Operation and maintenance (OAM)

11.1 OAM functional model

The OAM reference model of a VDSL2 link, as shown in Figure 11-1, contains OAM entities intended to manage the following transmission entities:

- *VDSL2 Line entity*: The physical transmission entity, which includes the PMD and PMS-TC sublayers;
- *VDSL2 Path entity*: The transport protocol path, which includes the TPS-TC sublayer; and
- *VDSL2 System entity*: The application path, which includes all relevant layers above the TPS-TC.

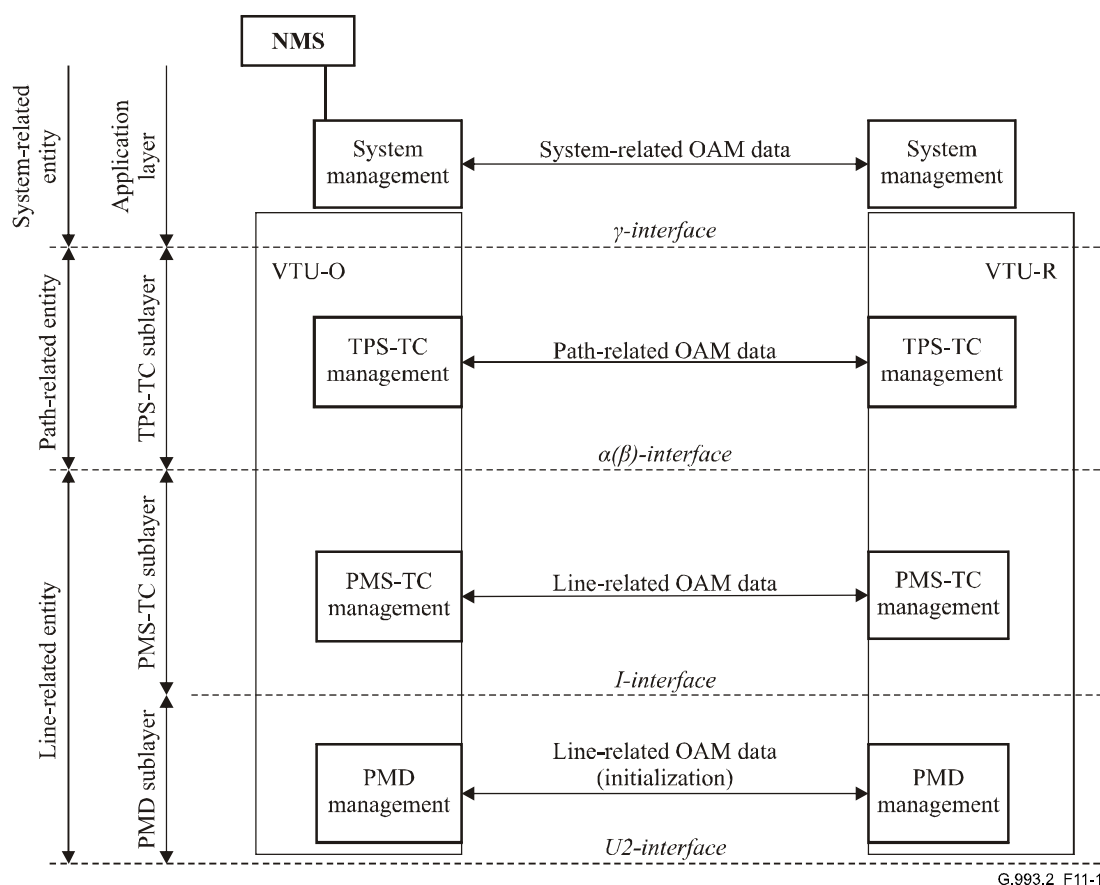

Figure 11-1 – OAM reference model

The peer OAM entities at the VTU-O and VTU-R exchange management data over OAM-dedicated communication channels arranged over the mentioned transmission entities. The NMS, located at the VTU-O, controls the OAM entities at both VTUs, and collects management data from all OAM entities. The OAM flows across the communication channels convey path-related and line-related primitives and parameters, configuration setups, and maintenance commands and acknowledgments.

The functional model of the OAM operation and communication over the VDSL2 link is presented in Figure 11-2. The external OAM interface adapter (EIA) provides the interface to the NMS (Q interface), and the interface with the MIB. The MIB contains all of the management information

related to the VDSL2 link. It may be implemented to serve an individual VDSL2 line or to be shared between several lines.

The VME collects the OAM data from and delivers it to all of the VTU transmission entities, thus providing all internal OAM functions for the VTU. It also supports all interactive management functions between the VTU-O and the VTU-R using two OAM-dedicated communication channels:

- Indicator bits (IB) channel; and
- Embedded operations channel (eoc).

The VME interfaces with the EIA, thus exchanging management data with the MIB. The VME functionality is specified in clause 11.2.1. The EIA functions concerning operation with the external interfaces (Ext_OAM_R interface, Q interface), with the MIB, and the interface between VME and EIA are beyond the scope of this Recommendation.

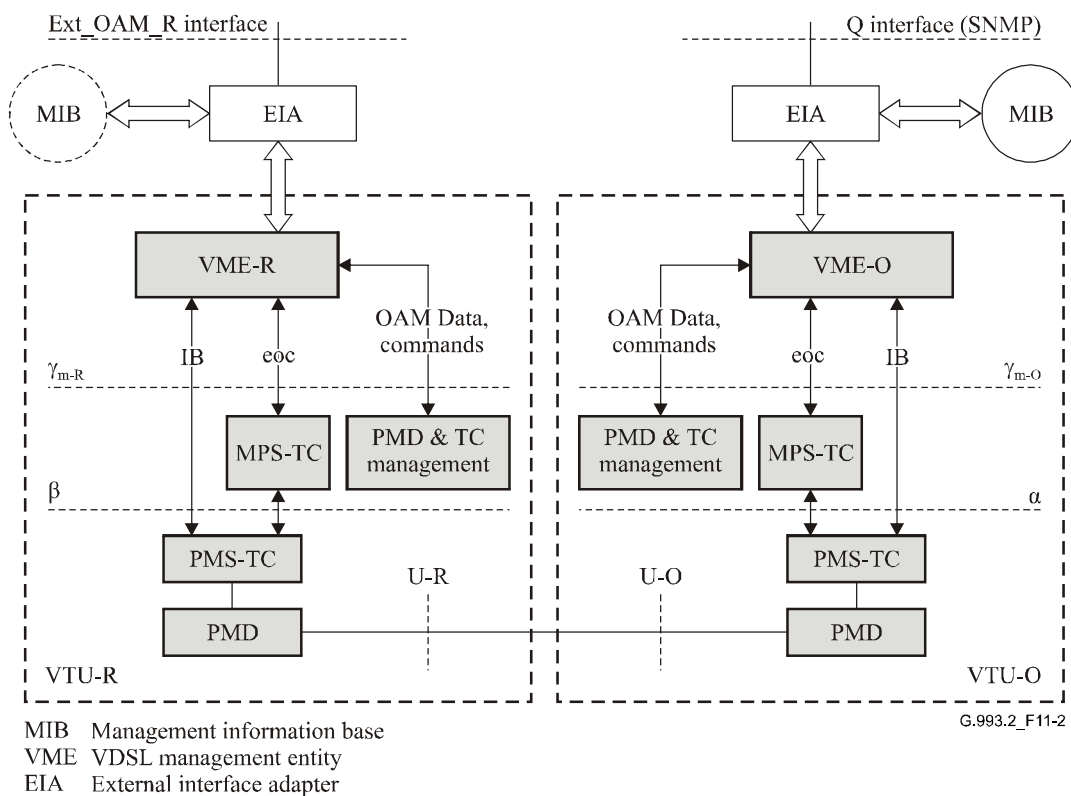

Figure 11-2 – Functional model of OAM of the VDSL2 link

To communicate management data, the VME uses eoc messages (specified in clause 11.2.3) and IB (specified in clause 11.2.4). The eoc messages and IB form a complete set of management data exchanged between the VTU-O and VTU-R, which includes the management data from all data-transmission sublayers of the VTU and the management data incoming from the EIA, including messages sent to the VTU-R. The latter are referred to in [ITU-T G.997.1] and in clause 11.2.3 as a "clear eoc". The interfaces between the VME and the TC sublayer for both OAM communication channels are functional and are defined in clause 8.2.2 (MPS-TC) and in clause 9.5.2.2 (IB). The eoc communication protocol is defined in clause 11.2.2.

The VME sends eoc messages via the γ_m interface to the management TPS-TC (MPS-TC) defined in clause 8.2.2. The MPS-TC encapsulates eoc messages into HDLC frames to transfer them over the VDSL2 link using the PMS-TC overhead channel (the MSG field of the OH frame specified in clause 9.5.2.2). At the receive side, the MPS-TC extracts the received eoc messages from HDLC frames and submits them to the VME via the γ_m interface.

For the IB transport no TPS-TC is needed; the IB are directly mapped to the IB field of the OH frame as specified in clause 9.5.2.2.

11.1.1 OAM communication channels

11.1.1.1 IB channel

The IB channel is shared for communication between the peer OAM entities of the PMD, PMS-TC and TPS-TC. It is intended to transfer time-sensitive primitives (those requiring an immediate action) from the far end. The IB channel operates in a unidirectional mode, i.e., the upstream and downstream directions of the IB channel operate independently, and there are no acknowledgements or retransmissions in the protocol. The IB are specified in clause 11.2.4.

11.1.1.2 eoc

The eoc is shared for communication between the peer OAM entities of the PMD, PMS-TC, TPS-TC and VME (system-related OAM data, such as power-related primitives). The eoc is mostly intended to exchange management data that is not time critical. It is used to transport clear eoc messages and MIB elements specified in [ITU-T G.997.1], to set and query parameters, and to invoke management procedures at the far-end VTU. The eoc provides exchange of the PMD, PMS-TC, TPS-TC and system-related primitives, performance parameters, test parameters, configuration parameters and maintenance commands. The eoc communication protocol is specified in clause 11.2.2.

11.2 VDSL2 management entity (VME)

11.2.1 VME functionality

The VME provides all necessary management functions specified in [ITU-T G.997.1] to communicate with the MIB and with the NMS via the EIA. It shall also manage the OAM communication channels, and support all internal management functions of the VTU, including:

- performance monitoring;
- performance management;
- configuration management; and
- fault management.

The VME shall provide all of the functionality to communicate the management data between the VTU-O and the VTU-R. Specifically, the VME shall:

- originate eoc messages and IB to communicate management data;
- assign priority levels for eoc messages to share the overhead messaging channel; and
- maintain the protocol of eoc message exchange (re-send messages, abandon certain tasks, etc.).

The VME-O shall update and store the set of near-end test parameters (the ones that can be updated during Showtime) within 10 seconds after receiving the request to do so from the NMS.

The VME-O shall update and store the set of far-end test parameters (the ones that can be updated during Showtime) within 30 seconds after receiving the request to do so from the NMS.

11.2.2 eoc transmission protocol

A VTU invokes eoc communication with the VTU at the other end of the link by sending an eoc command message. The responding VTU, acting as a slave, shall acknowledge a command it has received correctly by sending a response, unless one is not required for the particular command type. Furthermore, it shall perform the requested management function. Both VTUs shall be capable of sending eoc commands and responding to received eoc commands. The same eoc protocol format

shall be used in both transmission directions. To send commands and responses over the line, the VME originates eoc messages. Each eoc message is a command, a command segment, a response, or a response segment. The VME sends each eoc message to the MPS-TC.

The MPS-TC encapsulates all incoming messages into HDLC format, as specified in clause 8.2.3. The length of any eoc message shall be less than or equal to 1024 octets, as described in clause 11.2.3.1.

Each command and the corresponding response are associated with a priority level specified in clause 11.2.3.1. To maintain priorities of eoc commands when sent over the link, the VME shall send messages to the MPS-TC via the γ_m interface in accordance with the priority levels of the commands (responses) carried by these messages, as specified in Table 11-1.

Table 11-1 – eoc message priority levels

Priority level	Associated time-out value	eoc command (response)
High	400 ms	Table 11-2, UTC (see clause 11.2.3.2)
Near High	For further study	Table 11-3
Normal	800 ms	Table 11-4
Low	1 s	Table 11-5

The VME shall send the eoc command only once and wait for a response, if one is required. No more than one command of each priority level shall be awaiting a response at any time. Upon reception of the response, a new command of the same priority level may be sent. If the command is segmented, all the segments of the command shall be sent and responses received before the next command is sent.

Accordingly, the VME shall send the message carrying a command or a segment of a command only once and wait for a response message. Upon reception of the response message, a new message may be sent. If a response to a particular message is not received within a specified time period (see Table 11-1), or is received incorrectly, a time-out occurs. After a time-out, the VME shall re-send the message up until REINIT_TIME_THRESHOLD seconds from the first time-out after which it shall abandon the message.

From all of the messages available for sending at any time, the VME shall always send the message with highest priority first. If a message with a higher priority than the one that is currently being sent becomes available for sending, the VME may abort sending the lower priority message (by setting the *Tx_Stop* signal, as specified in clause 8.2.4.1). The VME shall re-send the aborted message as the priority rule allows (i.e., when its priority level is the highest among all messages available for sending).

Messages of different priority have different time-out durations, as shown in Table 11-1, except for messages for which a response is not required and hence no timeout period is applicable. Time-outs shall be calculated from the instant the MPS-TC sends the last octet of the message until the instant the VME receives the first octet of the response message. Accordingly, the time-out timer shall be started by the *Sent* signal. If the VME detects an *Rx_RF* signal and a corresponding *Rx_PrF* signal within the relevant time-out value specified in Table 11-1, it shall set a time stamp for the preliminary arrival time of the expected response message, and then wait for the *Rx_Enbl* signal; otherwise the VME shall time-out for the expected response.

If the VME detects the *Rx_Enbl* signal in ≤ 300 ms after *Rx_RF* and *Rx_PrF* signals are set, the response message is considered to be received; otherwise, the VME shall consider the received *Rx_RF* and *Rx_PrF* signals as false, and shall delete the time stamp and wait for the next *Rx_RF* and *Rx_PrF* signals within the rest of the time-out value specified in Table 11-1.

The receiver uses the assigned value specified in clause 11.2.3.2 to determine the type and priority of the received eoc command (response).

11.2.3 eoc commands and responses

11.2.3.1 General

The first octet of a command (response) specifies the type of command (response). The second octet specifies the name of the command (response) for the specified type. Other octets carry the management data associated with the command (response).

The data values to be sent shall be mapped such that the LSB of data is mapped to the LSB of the corresponding octet of the command (response). Data values containing more than one octet shall be mapped with higher order octets preceding lower order octets. A vector of data values shall be mapped in order of the index, from the lowest index value to the highest.

If a specific command (response) is longer than 1024 octets, the VME shall segment it as specified in clause 11.2.3.3 so that the length of the eoc messages sent is shorter than P octets. The maximum length P of the message shall be based on the assigned message overhead data rate in the relevant transmission direction using the following equation:

$$P \leq \min(1024, 33 \times msg_p) \text{ octets,}$$

where:

msg_p = message overhead data rate for latency path p in kbit/s (specified in clause 9.5.4).

NOTE – With the defined value of P , the transmission time of any eoc message will not exceed 270 ms (including 3% loss due to HDLC overhead and stuffing). This ensures that in all regular cases the VME will not be forced to stop sending a low-priority message in order to comply with the time-out requirements presented in Table 11-1. The VME should avoid long commands and responses.

11.2.3.2 Command and response types

With the exception of control parameter read, which is for further study, the VTU shall support all mandatory eoc command and response types specified in Table 11-2 (high priority commands), Table 11-3 (near high priority commands), Table 11-4 (normal priority commands) and Table 11-5 (low priority commands), and their associated commands and responses specified in clauses 11.2.3.3 to 11.2.3.11, inclusive. The VTU should reply with Unable-To-Comply (UTC) response on the optional commands that the VTU cannot recognize the assigned value for the command type. The UTC response shall include two octets: the first octet of the UTC shall be the same as the first octet of the received command, and the second octet shall be FF₁₆. The UTC is a high priority response.

NOTE – If the UTC response is not supported, the command will time out. This would reduce the efficiency of the eoc.

Table 11-2 – High priority commands and responses

Command type and assigned value	Direction of command	Command content	Response content	Support
On-line reconfiguration (OLR) 0000 0001 ₂	From the receiver of either VTU to the transmitter of the other	All the necessary PMD and PMS-TC control parameter values for the new configuration	Includes either a line signal marking the instant of re-configuration (Syncflag), or an OLR intermediate acknowledge (for segmented command), or an OLR command to defer or reject the proposed reconfiguration	See Table 11-6
Power Management 0000 0111 ₂	From either VTU to the other	High priority LPM commands defined in Annex E of [ITU-T G.998.4]	An acknowledgement or reject of high priority LPM command as defined in Annex E of [ITU-T G.998.4]	Optional

Table 11-3 – Near high priority commands and responses

Command type and assigned value	Direction of command	Command content	Response content	Support
Frequency synchronization 0101 0000 ₂	From VTU-O to VTU-R	The ToD phase difference value to run frequency synchronization: the ns_counter value of the RTC-O mod 125000 ns divided by 2, which shall be represented by a 16 bit value.	No response needed	Optional

Table 11-4 – Normal priority commands and responses

Command type and assigned value	Direction of command	Command content	Response content	Support
Diagnostic 0100 0001 ₂	From VTU-O to VTU-R	Request to run the self-test, or to update test parameters, or to start and stop transmission of corrupt CRC, or to start and stop reception of corrupt CRC	Acknowledgment	Mandatory
	From VTU-R to VTU-O	Request to update test parameters	Acknowledgment	Mandatory
Time 0100 0010 ₂	From VTU-O to VTU-R	Set or read out the time	Acknowledgment of the set time command, or a response including the time value	Mandatory
Inventory 0100 0011 ₂	From either VTU to the other	Identification request, auxiliary inventory information request, and self-test results request	Includes the VTU equipment ID auxiliary inventory information, and self-test results	Mandatory
Management counter read 0000 0101 ₂	From either VTU to the other	Request to read the counters	Includes all counter values	Mandatory
Clear eoc 0000 1000 ₂	From either VTU to the other	Clear eoc command as defined in [ITU-T G.997.1]	Acknowledgment	Mandatory
Power Management 0000 0111 ₂	From either VTU to the other	Proposed new power state, or normal priority LPM commands defined in Annex E of [TU-T G.998.4]	An acknowledgement to either reject or grant the new power state, or acknowledgement or reject of normal priority LPM command as defined in Annex E of [ITU-T G.998.4]	Mandatory
Non-standard facility (NSF) 0011 1111 ₂	From either VTU to the other	Non-standard identification field followed by vendor proprietary content	An acknowledgment or a negative acknowledgment indicating that the non-standard identification field is not recognized	Mandatory
Control parameter read 0000 0100 ₂	From either VTU to the other	For further study	For further study	Mandatory

Table 11-4 – Normal priority commands and responses

Command type and assigned value	Direction of command	Command content	Response content	Support
Time synchronization 0101 0001 ₂	From VTU-O to VTU-R	Includes the time stamps obtained by VTU-O to run time synchronization	Includes either the corresponding time stamp values of events t_2 and t_3 to accept the time synchronization (ACK) or a reject of the time synchronization command with a reason code	Optional
SAVN-Update 1010 0001 ₂	From VTU-O to VTU-R	Request to update the showtime adaptive virtual noise (SAVN)	Acknowledgment	Optional

Table 11-5 – Low priority commands and responses

Command type and assigned value	Direction of command	Command content	Response content	Support
PMD test parameter read 1000 0001 ₂	From either VTU to the other	The identification of test parameters for single read, or for multiple read, or for block read	Includes the requested test parameter values or a negative acknowledgment	See Tables 11-26 and 11-27
INM facility 1000 1001 ₂	From VTU-O to VTU-R	Set or readout the INM data	An acknowledgment of the INM facility set command, or a response including the INM data	Optional
Non-standard facility (NSF) Low Priority 1011 1111 ₂	From either VTU to the other	Non-standard identification field followed by vendor proprietary content	An acknowledgment or a negative acknowledgment indicating that the non-standard identification field is not recognized	Mandatory
Data gathering 1100 1100 ₂	From VTU-O to VTU-R	Configure data gathering or request a number of data gathering records	ACK/NACK the data gathering configuration or transfer data gathering records	Optional

11.2.3.3 On-line reconfiguration (OLR) commands and responses

The VTU shall be capable of sending and receiving the OLR commands and responses listed in Tables 11-6 and 11-7, respectively, for the supported type(s) of OLR (see clause 13.1). Any OLR command specified in Table 11-6 may be initiated by either VTU. The responding VTU may either reject the initiator's request using responses listed in Table 11-7 with reason codes listed in Table 11-8, or positively acknowledge the initiator's request by transmitting a time marker for the reconfiguration. The time marker shall be communicated by transmission of a Syncflag (see clause 10.5.3). Changes may be requested concurrently by both VTUs; each transaction shall follow the procedure described in this clause.

The first octet of all OLR commands and responses shall be the assigned value for the OLR command type, as shown in Table 11-2. The remaining octets shall be as shown in Table 11-6 (for commands) and in Tables 11-7 and 11-8 (for responses). The octets of the OLR commands and responses shall be sent over the link as described in clause 11.2.3.1.

The list of parameters for any command in Table 11-6 shall be selected such that the length of the eoc message in octets (prior to HDLC encapsulation) does not exceed the maximum length P specified in clause 11.2.3.1. If more parameters are to be re-configured simultaneously, the initiator shall segment the Request command to meet the maximum message size. The number of segments shall not exceed 64. The multi-segment transmission is supported by the segment code (SC) octet in the Request command and by the intermediate acknowledge (IACK) octet in the response. The responding VTU shall send an IACK response after every intermediate segment has been received. After all segments have been received, the responding VTU shall send the Defer or Reject response with a reason code if the request cannot be processed, or send the time marker (Syncflag, see clause 10.5.3) to implement the request. The requesting VTU shall not send the next segment until it receives the IACK for the current segment. If an IACK for an intermediate segment is not received before the time-out, the requesting VTU may either re-send it or abandon the request. The responding VTU shall consider the OLR command abandoned if no more valid segments are received within 1 second of the last segment.

The two MSBs of the SC shall be set to 00_2 for intermediate segments, and set to 11_2 for the last segment. The 6 LSBs shall contain the serial number of the segment starting from 000000_2 . The SC octet of an IACK shall be the same as the SC octet of the acknowledged segment.

Table 11-6 – OLR commands sent by the initiating VTU

Name	Length (octets)	Octet number	Content	Support
Request Type 1	$5 + 4 \times N_f$ ($N_f \leq 128$)	2	04_{16} (Note 1)	Mandatory
		3 to 4	2 octets for the number of subcarriers N_f to be modified	
		5 to $4 + 4 \times N_f$	$4 \times N_f$ octets describing the subcarrier parameter field for each subcarrier	
		$5 + 4 \times N_f$	1 octet for SC	
Request Type 2	For further study	2	05_{16} (Note 1)	For further study
		All others	Reserved by ITU-T	
Request Type 3 (SRA) (Note 6)	$5 + 7 N_{LP} + 4 N_f$ ($N_f \leq 128$)	2	06_{16} (Note 1)	Optional
		3 to $2 + 2 N_{LP}$	$2 \times N_{LP}$ octets containing the new L_p values for each of the active latency paths (N_{LP} = number of active latency paths) (Notes 2 and 3)	
		$3 + 2 N_{LP}$ to $2 + 4 N_{LP}$	$2 \times N_{LP}$ octets containing the new D_p values for each of the active latency paths (N_{LP} = number of active latency paths) (Note 4)	
		$3 + 4 N_{LP}$ to $2 + 5 N_{LP}$	N_{LP} octets containing the new T_p values for each of the active latency paths (N_{LP} = number of active latency paths) (Notes 2, 3, 5)	

Table 11-6 – OLR commands sent by the initiating VTU

Name	Length (octets)	Octet number	Content	Support	
		3 + 5 N_{LP} to 2 + 6 N_{LP}	N_{LP} octets containing the new G_p values for each of the active latency paths (N_{LP} = number of active latency paths) (Notes 2, 3, 5)		
		3 + 6 N_{LP} to 2 + 7 N_{LP}	N_{LP} octets containing the new B_{p0} values for each of the active latency paths (N_{LP} = number of active latency paths) (Notes 2, 3, 5)		
		3 + 7 N_{LP} to 4 + 7 N_{LP}	2 octets for the number of subcarriers N_f to be modified		
		5 + 7 N_{LP} to 4 + 7 N_{LP} + 4 N_f	4 N_f octets describing the subcarrier parameter field for each subcarrier		
		5 + 7 N_{LP} + 4 N_f	1 octet for Segment Code (SC)		
Request Type 4 (SOS)	$N_{TG}/2+11$	2	07 ₁₆ (Note 1)	Optional	
		3	Message ID		
		4 to $N_{TG}/2+3$	$\Delta b(2)$		$\Delta b(1)$
			$\Delta b(4)$		$\Delta b(3)$
			...		
			$\Delta b(N_{TG})$		$\Delta b(N_{TG} - 1)$
		$N_{TG}/2+4$ to $N_{TG}/2+5$	New value for L_0		
		$N_{TG}/2+6$ to $N_{TG}/2+7$	New value for L_1		
		$N_{TG}/2+8$ to $N_{TG}/2+9$	New value for D_0		
$N_{TG}/2+10$ to $N_{TG}/2+11$	New value for D_1				
Request Type 5 (SRA/G.998.4)	See ITU-T G.998.4	2	08 ₁₆ (Note 1)	Optional	
		All others	Reserved for ITU-T G.998.4		
Request Type 6 (SOS/G.998.4)	See ITU-T G.998.4	2	09 ₁₆ (Note 1)	Optional	
		All others	Reserved for ITU-T G.998.4		

NOTE 1 – All other values for octet number 2 are reserved by ITU-T.

NOTE 2 – For this command, any change in L_p , T_p , G_p , and B_{p0} values shall be such that the length of the MDF (as defined in Table 9-8) remains unchanged for all active latency paths.

NOTE 3 – To keep the msg_p value within its valid range for relatively large changes of L_p , it may be necessary to change all of the T_p , G_p , and B_{p0} values.

NOTE 4 – If a change of D_p is not supported, the value of this parameter shall be identical to that currently used.

NOTE 5 – If a change of T_p , G_p and B_{p0} is not supported, the values of these parameters shall be identical to those currently used.

NOTE 6 – When $N_{LP} = 2$, the octets associated with latency path 0 are sent first.

The message ID identifies an SOS request. The message ID shall be an 8 bit wrap-around counter. The initial value of the message ID shall be set to 0 for the first SOS request after entering Showtime.

When the SOS message is repeated, the same message ID shall be maintained for as long as the same request is sent. The next SOS request shall use a message ID that is incremented by 1.

The parameter N_{TG} is the number of SOS tone groups as specified for SOS in the O/R-PMS messages (see Table 12-56, Table 12-64).

$\Delta b(k)$ is the bit loading reduction in SOS tone group $\#k$. These values shall be coded as 4-bit unsigned integers. The number of SOS tone groups shall be derived from the information exchanged in O-PMS and R-PMS. If that number is odd, the most significant four bits in byte $\#N_{TG}/2+3$ shall be set to zero at the transmitter and ignored by the receiver.

An SOS request may be repeated before the SOS request time-out has expired. It is up to the VTU that receives the request to recognize that this is the same SOS request. Once its transmitter has acknowledged a request with given message ID (by sending a Syncflag), it shall ignore subsequent SOS requests with the same message ID.

For single latency with ROC mode, the L and D values for latency path $\#0$ shall be ignored by the receiver.

Table 11-7 – OLR responses sent by the responding VTU

Name	Length (octets)	Octet number	Content	Support
Defer Type 1 request	3	2	81 ₁₆ (Note)	Mandatory
		3	1 octet for reason code (Table 11-8)	
Reject Type 2 request	3	2	82 ₁₆ (Note)	For further study
		3	1 octet for reason code (Table 11-8)	
Reject Type 3 request	3	2	83 ₁₆ (Note)	Optional
		3	1 octet for reason code (Table 11-8)	
Reject Type 4 request	3	2	84 ₁₆ (Note)	Optional
		3	1 octet for reason code (Table 11-8)	
Reject Type 5 request	3	2	85 ₁₆ (Note)	Optional
		3	1 octet for reason code (Table 11-8)	
Reject Type 6 request	3	2	86 ₁₆ (Note)	Optional
		3	1 octet for reason code (Table 11-8)	
IACK	3	2	8B ₁₆ (Note)	Mandatory
		3	1 octet for SC	
NOTE – All other values for octet number 2 are reserved by ITU-T.				

Each subcarrier parameter field shall contain 4 octets formatted as [0000 iiiiiiii iiiiiiii ggggg ggggg ggggg bbbbbb] to convey the g_i (12 bits) and the b_i (4 bits) values of the subcarrier index i (12 bits). The subcarrier index i shall be coded in the four LSBs of the first octet and the entire second octet of the subcarrier field. The LSBs of the subcarrier index i shall be contained in the second octet. The g_i shall be contained in the third octet and the four MSBs of the fourth octet. The LSBs of g_i shall be contained in the fourth octet. The b_i shall be contained in the four LSBs of the fourth octet.

Table 11-8 – Reason codes for OLR responses

Reason	Octet value	Applicable to Defer Type 1	Applicable to Reject Type 2	Applicable to Reject Type 3	Applicable to Reject Type 4
Busy	01 ₁₆	yes	yes	yes	no
Invalid parameters	02 ₁₆	yes	yes	yes	yes

Upon sending an OLR command, the initiator shall await a response. The OLR response may be deferring or rejecting the reconfiguration, or it may be a Syncflag indicating when the reconfiguration shall take effect. If the initiator receives an OLR response to defer or reject the change, it shall abandon the last requested OLR command. A new command may be initiated immediately, including the command abandoned, rejected or deferred earlier.

NOTE 1 – In the case of reason code 02₁₆, repeating of the OLR request is not expected to be helpful.

NOTE 2 – When an OLR command has been sent, the initiator has no means to cancel the command. The initiator needs to wait for a response or a time-out before it can send a different OLR command. For example, if the SOS triggering conditions become active when there is a pending bitswap or SRA, the SOS request needs to be delayed until full execution or time-out of the bitswap/SRA procedure.

Upon reception of an OLR command, the responder shall send either an OLR response to defer or to reject the reconfiguration, or a Syncflag that indicates when the reconfiguration shall take effect. After sending the Syncflag, the responder shall reconfigure the affected PMD, PMS-TC, and TPS-TC functions starting from the tenth symbol in the next DMT superframe, as described in clause 13.3. The responder may defer or reject the OLR request; in this case it shall supply a reason code from those specified in Table 11-8.

Upon reception of the Syncflag, the initiator shall reconfigure the affected PMD or PMS-TC functions starting from the tenth DMT symbol in the next DMT superframe, as described in clause 13.3.

11.2.3.4 Diagnostic commands and responses

The Diagnostic commands shall be used to control the VTU diagnostic capabilities defined in this clause. The Diagnostic commands shown in Table 11-9 may be initiated only by the VTU-O. The Diagnostic commands shown in Table 11-10 may be initiated only by the VTU-R. The responses are shown in Table 11-11. All Diagnostic commands and responses shall consist of two or three octets. The first octet shall be the assigned value for the Diagnostic command type, as shown in Table 11-4. The second and subsequent octets shall be as shown in Tables 11-9 and 11-10 for commands and in Table 11-11 for responses. The octets shall be sent using the format described in clause 11.2.3.1.

Table 11-9 – Diagnostic commands sent by the VTU-O

Name	Length (Octets)	Octet number	Content
Perform Self-test	2	2	01 ₁₆ (Note)
Update Test Parameters	2	2	02 ₁₆ (Note)
Start TX Corrupt CRC	2	2	03 ₁₆ (Note)
End TX Corrupt CRC	2	2	04 ₁₆ (Note)
Start RX Corrupt CRC	2	2	05 ₁₆ (Note)
End RX Corrupt CRC	2	2	06 ₁₆ (Note)
NOTE – All other values for octet number 2 are reserved by ITU-T.			

Table 11-10 – Diagnostic commands sent by the VTU-R

Name	Length (Octets)	Octet number	Content
Update test Parameters	2	2	02 ₁₆ (Note)
NOTE – All other values for octet number 2 are reserved by ITU-T.			

Table 11-11 – Diagnostic responses sent by the VTU

Name	Length (Octets)	Octet number	Content
Self-test Acknowledge (VTU-R only)	3	2	01 ₁₆ (Note)
		3	1 octet for the minimum time in seconds the VTU-O shall wait before requesting the self-test result
ACK (VTU-O and VTU-R)	2	2	80 ₁₆ (Note)
NOTE – All other values for octet number 2 are reserved by ITU-T.			

A Diagnostic command may be sent at any time during showtime, including immediately following the end of the initialization procedure. In all cases, reception of a Diagnostic command shall be acknowledged to the initiator (by an ACK or by a Self-test Acknowledge response).

NOTE – A negative acknowledge (NACK) is not used for Diagnostic commands.

11.2.3.4.1 Perform Self-test

Upon reception of the Perform Self-test command, the VTU-R shall respond with a Self-test Acknowledge, which indicates the minimum amount of time that the VTU-O shall wait before requesting the results of the self-test. Further, the VTU-R shall perform the self-test and generate the self-test result. The self-test procedure is vendor discretionary, but it shall not interfere with the functions of the VTU-R, shall not impact the status of the connection, and its duration shall not exceed 255 s. The VTU-R shall obtain and store the result of the self-test within the number of seconds indicated in the Self-test Acknowledge response. The indicated amount of time shall be an integer between 1 and 255 s.

The self-test results may be accessed using the Inventory command defined in clause 11.2.3.6. The length of the self-test results shall be 4 octets. The first octet (including the MSB) shall be 00₁₆ if the self-test passed and 01₁₆ if it failed. The meaning of "failure" is vendor discretionary. The contents of the three other octets are vendor discretionary.

11.2.3.4.2 Update Test Parameters

Upon reception of the Update Test Parameters command, the requested VTU shall send the ACK response and update the test parameter set defined in clause 11.4.1. All test parameters that can be updated during showtime shall be updated and stored within 10 s after the request is received. Upon reception of the ACK response, the requesting VTU shall wait at least 10 s before sending the PMD Test Parameter Read commands defined in clause 11.2.3.11 to access the test parameter values defined in clause 11.4.1.

The test parameter values relating to the most recent initialization procedure shall no longer be accessible through the Test Parameter Read commands within 10 s after the Update Test Parameters command was received. They may be discarded by the responding VTU immediately upon reception of the Update Test Parameter command.

11.2.3.4.3 Start/End transmitter Corrupt CRC

Upon reception of the Start Transmitter (TX) Corrupt Cyclic Redundancy Check (CRC) command, the VTU-R shall send the ACK response and its PMS-TC shall generate a corrupted CRC value in all transmitted latency paths until cancelled by the End TX Corrupt CRC command. A corrupted CRC value is any one that does not correspond to the CRC procedure specified in clause 9.5.2.3. The Start TX Corrupt CRC command shall affect only the CRC value transmitted by the VTU-R; the PMS-TC function of the VTU-O shall not be affected by this command.

Upon reception of the End TX Corrupt CRC command, the VTU-R shall send the ACK response and its PMS-TC shall generate CRC values in all latency paths as specified in clause 9.5.2.3. The End TX Corrupt CRC command shall not affect the PMS-TC function of the VTU-R if the Start TX Corrupt CRC command has not been sent earlier.

11.2.3.4.4 Start/End receiver Corrupt CRC

Upon reception of the Start receiver (RX) Corrupt Cyclic Redundancy Check (CRC) command, the VTU-R shall send the ACK response. Upon reception of this ACK response by the VTU-O, its PMS-TC function shall generate a corrupted CRC value in all transmitted latency paths until cancelled by the End RX corrupt CRC command. A corrupted CRC value is any one that does not correspond to the CRC procedure specified in clause 9.5.2.3. The Start RX Corrupt CRC command shall affect only the CRC value transmitted by the VTU-O; the PMS-TC function of the VTU-R shall not be affected by this command.

Upon reception of the End RX Corrupt CRC command, the VTU-R shall send the ACK response. Upon reception of this ACK response, the PMS-TC function at the VTU-O shall generate CRC values in all latency paths as specified in clause 9.5.2.3. The End RX Corrupt CRC command shall not affect the PMS-TC function of the VTU-O if the Start RX Corrupt CRC command has not been sent earlier.

NOTE – The Start RX Corrupt CRC command may be used in conjunction with the Transmit Corrupt CRC command (either previously or subsequently) so that CRC values are set corrupted in both directions of transmission.

11.2.3.5 Time commands and responses

Both VTUs shall maintain timers to update performance monitoring counters as described in [ITU-T G.997.1]. The time commands shall be used to synchronize timers at both ends of the link. The timers shall have an accuracy of ± 100 ppm or better.

NOTE – The counters defined in [ITU-T G.997.1] should be updated each time the time counter contains a time value that is an integer multiple of 15 minutes (e.g., 1:00:00, 3:15:00, 15:30:00, 23:45:00).

The time commands are shown in Table 11-12, and may only be initiated by the VTU-O. The VTU-R shall reply using one of the responses shown in Table 11-13. The first octet of all time commands and responses shall be the assigned value for the time command type, as shown in Table 11-4. The remaining octets shall be as specified in Tables 11-12 and 11-13 for commands and responses, respectively. The octets shall be sent using the format described in clause 11.2.3.1.

Table 11-12 – Time commands sent by the VTU-O

Name	Length (Octets)	Octet number	Content
Set Time	10	2	01 ₁₆ (Note)
		3 to 10	8 octets for time value formatted as HH:MM:SS per [ISO 8601]
Read Time	2	2	02 ₁₆ (Note)

NOTE – All other values for octet number 2 are reserved by ITU-T.

Table 11-13 – Time responses sent by the VTU-R

Name	Length (Octets)	Octet number	Content
ACK	2	2	80 ₁₆ (Note)
Time	10	2	82 ₁₆ (Note)
		3 to 10	8 octets for time value formatted as HH:MM:SS per [ISO 8601]
NOTE – All other values for octet number 2 are reserved by ITU-T.			

Upon reception of the Set Time command, the VTU-R shall send the ACK response, and set its timer to the value contained in the message.

Upon reception of the Read Time command, the VTU-R shall send the Time response that includes the current value of the VTU-R timer.

11.2.3.6 Inventory commands and responses

The Inventory commands shall be used to determine the identification and capabilities of the VTU at the far end. The Inventory commands shown in Table 11-14 may be initiated by either VTU. The Inventory responses shall be as shown in Table 11-15. The first octet of all Inventory commands and responses shall be the assigned value for the Inventory command type, as shown in Table 11-4. The second octet of the Inventory commands shall be as specified in Table 11-14. The second octet (ACK) and all following octets of the Inventory responses shall be as specified in Table 11-15. The octets shall be sent using the format described in clause 11.2.3.1.

Table 11-14 – Inventory commands sent by the requesting VTU

Name	Length (Octets)	Octet number	Content
Identification request	2	2	01 ₁₆ (Note)
Auxiliary Inventory Information request	2	2	02 ₁₆ (Note)
Self-test Results Request	2	2	03 ₁₆ (Note)
Initialization Flags Request	2	2	04 ₁₆ (Note)
Initialization Flags Reset Request	2	2	05 ₁₆ (Note)
NOTE – All other values for octet number 2 are reserved by ITU-T.			

Table 11-15 – Inventory responses sent by the responding VTU

Name	Length (Octets)	Octet number	Contents
ACK (Identification)	58	2	81 ₁₆ (Note)
		3 to 10	8 octets of vendor ID
		11 to 26	16 octets of version number
		27 to 58	32 octets of serial number
ACK (Auxiliary Inventory Information)	variable	2	82 ₁₆ (Note)
		3 to 10	8 octets of vendor ID
		11 +	Multiple octets of auxiliary inventory information
Self-test Results	6	2	83 ₁₆ (Note)
		3 to 6	4 octets of self-test results
Initialization Flags	3	2	84 ₁₆ (Note)
		3	1 octet with the value of the initialization flags.
Initialization Flags Reset	3	2	85 ₁₆ (Note)
		3	1 octet with the value of the initialization flags before the reset.
NOTE – All other values for octet number 2 are reserved by ITU-T.			

Upon reception of one of the Inventory commands, the VTU shall send the corresponding response. Any function of either the requesting or the responding VTU shall not be affected by the command.

The vendor ID in the response identifies the system integrator and shall be formatted according to the vendor ID of [ITU-T G.994.1]. In the context of this request, the system integrator usually refers to the vendor of the smallest field-replaceable unit; thus, the vendor ID in the response may not be the same as the vendor ID indicated during the ITU-T G.994.1 handshake phase of initialization.

The VTU-O version number shall be as defined in clause 7.4.5 of ITU-T G.997.1.

The VTU-R version number shall be as defined in clause 7.4.6 of ITU-T G.997.1.

The VTU-O serial number shall be as defined in clause 7.4.7 of ITU-T G.997.1.

The VTU-R serial number shall be as defined in clause 7.4.8 of ITU-T G.997.1.

The auxiliary inventory information shall be assigned with respect to the same system integrator as contained in the vendor ID. The syntax of this field is beyond the scope of this Recommendation.

The Self-test Results response shall contain the results from the most recent self-test procedure, initiated either at power-up or by the eoc command Perform Self-test. The results shall be formatted as defined in clause 11.2.3.4.1.

The eoc commands Initialization Flags Request and the Initialization Flags Reset Request shall only be supported from the VTU-O to the VTU-R. The responses to those commands are optional.

The Initialization Flags and the Initialization Flags Reset response shall contain the current value of the initialization flags. The following initialization flags are defined:

- The "previous-loss-of-power" (PLPR) flag: This flag shall be set to 1 after a power-up of the VTU-R due to an interruption in the VTU-R electrical supply (mains) power. The flag shall be set to 0 after sending the Initialization Flags Reset response.

- The "previous host re-init" (PHRI) flag: This flag shall be set to 1 after a power-up of the VTU-R triggered by the CPE host. The flag shall be set to 0 after sending the Initialization Flags Reset response.

The value of the initialization flags shall be formatted as 1 octet [0000 00ba] where "a" is the value of the PLPR flag and "b" is the value of the PHRI flag.

11.2.3.7 Management counter read commands and responses

The Management counter read request command shall be used to retrieve the current value of certain management counters maintained by the far-end VTU in accordance with [ITU-T G.997.1]. The Management counter read request command is shown in Table 11-16, and may be initiated by either VTU and is used to request the values of the counters. The response shall be as shown in Table 11-17. The first octet of the command and response shall be the assigned value for the Management counter read command type, as shown in Table 11-4. The second octet of the command shall be as shown in Table 11-16. The second and all following octets of the response shall be as shown in Table 11-17. The octets shall be sent using the format described in clause 11.2.3.1.

Table 11-16 – Management counter read commands sent by the requesting VTU

Name	Length (Octets)	Octet number	Content
Request	2	2	01 ₁₆ (Note)
NOTE – All other values for octet number 2 are reserved by ITU-T.			

Table 11-17 – Management counter read responses sent by the responding VTU

Name	Length (Octets)	Octet number	Content
ACK	variable	2	81 ₁₆ (Note 1)
		3 to $2 + 4 \times (2 \times N_{LP} + 5)$	Octets for all of the PMS-TC counter values (Note 2)
		$3 + 4 \times (2 \times N_{LP} + 5)$ and above	Octets for all of the TPS-TC counter values (Note 2)
NOTE 1 – All other values for octet number 2 are reserved by ITU-T.			
NOTE 2 – N_{LP} is the number of enabled latency paths.			

Upon reception of the management counter read request command, the VTU shall send the response. Any function of either the requesting or the responding VTU shall not be affected by the command.

The management counter values shall be derived according to [ITU-T G.997.1] from locally generated defects and anomalies defined within clause 11.3. The parameters shall be transferred in the order (top to bottom) defined in Table 11-18. The TPS-TC anomaly definitions and relevant management counters are dependent upon the TPS-TC type and shall be as defined in Annex L. All counter values are defined as 32-bit counters and shall be mapped to the response in order of most significant to least significant octet. No octets shall be inserted into the response for latency paths and TPS-TC functions that are currently disabled.

The counters shall be reset at power-up, and shall not be reset upon a link state transition, and shall not be reset upon read. The time periods when the VTU is powered but not in the showtime state shall be counted as unavailable seconds (see clause 7.2.1.1.5 of [ITU-T G.997.1]).

Table 11-18 – VTU management counters

PMS-TC counters
Counter of the FEC-0 anomalies
Counter of the FEC-1 anomalies
Counter of the CRC-0 anomalies
Counter of the CRC-1 anomalies
FEC errored seconds counter
Errored seconds counter
Severely errored seconds counter
<i>los</i> errored seconds counter
Unavailable errored seconds counter
TPS-TC counters
Counters for TPS-TC #0
Counters for TPS-TC #1

NOTE – The VTU-O should respond to the request from the NMS to read the values of management counters. It is left to the implementations to store and update the counters as necessary for accurate error monitoring and reporting.

11.2.3.8 Clear eoc commands and responses

The Clear eoc Request command may be used by the ITU-T G.997.1 function to transfer management octets between the EIA and the VTU-R and from one VTU to another (see clause 6 of [ITU-T G.997.1]). The Clear eoc Request command is shown in Table 11-19 and may be initiated by either VTU. The responses shall be as shown in Table 11-20. The first octet of either the command or a response shall be the assigned value for the Clear eoc command type shown in Table 11-4. The subsequent octets of the command shall be as shown in Table 11-19. The subsequent octets of the responses shall be as shown in Table 11-20. The octets shall be sent using the format described in clause 11.2.3.1.

NOTE – In accordance with [ITU-T G.997.1], the information payload of the Clear eoc message does not exceed 510 octets. Therefore, the length of either a Clear eoc Request command or a response does not exceed 516 octets.

Table 11-19 – Clear eoc commands sent by the initiating VTU

Name	Length (Octets)	Octet number	Content
Request	variable	2	01 ₁₆ (Note)
		3 +	the information payload of the clear eoc message to be delivered to the far end
NOTE – All other values for octet number 2 are reserved by ITU-T.			

Table 11-20 – Clear eoc responses sent by the responding VTU

Name	Length (Octets)	Octet number	Content
ACK	2	2	80 ₁₆ (Note)
NACK	3	2	81 ₁₆ (Note)
		3	04 ₁₆ (Note)
NOTE – All other values for octet numbers 2 and 3 are reserved by ITU-T.			

Upon reception of the Clear eoc Request command, the VTU shall respond with an acknowledgement (ACK) and deliver the received clear eoc message to the local ITU-T G.997.1 management function transparently, with the original formatting used by the ITU-T G.997.1 management function of the initiating VTU. The VTU may instead respond with a negative acknowledge (NACK) including the Not Supported (value 04₁₆) reason code, indicating that the received clear eoc message cannot be delivered to the ITU-T G.997.1 management function (because the ITU-T G.997.1 management function may not support clear eoc messages; see clause 6 of [ITU-T G.997.1]). Other reason codes are for further study.

11.2.3.9 Power management commands and responses

The Power Management L3 Request command shall be used to propose a power management transition to link state L3. The Power Management L3 Request command is shown in Table 11-21 and may be initiated by either VTU. The responses shall be as shown in Table 11-22. The first octet of either the command or a response shall be the assigned value for the Power Management command type, as shown in Table 11-4. The remaining octets shall be as shown in Tables 11-21 and 11-22 for commands and responses, respectively.

Table 11-21 – Power management commands sent by the initiating VTU

Name	Length (Octets)	Octet number	Content
L3 Request	3	2	01 ₁₆ (Note)
		3	03 ₁₆ (Note)
NOTE – All other values for octet numbers 2 and 3 are reserved by ITU-T.			

Table 11-22 – Power management responses sent by the responding VTU

Name	Length (Octets)	Octet number	Content
Grant	2	2	80 ₁₆ (Note)
Reject	3	2	81 ₁₆ (Note)
		3	1 octet for reason code
NOTE – All other values for octet number 2 are reserved by ITU-T.			

Reason codes associated with the power management commands are shown in Table 11-23.

Table 11-23 – Reason codes for power management commands

Reason	Octet value
Busy	01 ₁₆
Invalid	02 ₁₆
State not desired	03 ₁₆

11.2.3.9.1 L3 Request by VTU-R

Upon receipt of the L3 Request command, the responding VTU-O shall send either the Grant or Reject response. The proposed link state shall be formatted as 03₁₆ for the L3 link state. If any other link state is received, the Reject response shall be sent with the reason code 02₁₆.

The VTU-O may reject a request to move to link state L3 using reason code 01₁₆ because it is temporarily too busy, or reject it using code 03₁₆ because it has local knowledge that the L3 state is not desired at this time. Upon receipt of the L3 Request command, the VTU-O may immediately start the protocol to request a transition to the L3 state.

If the VTU-R receives the Grant response, the VTU-R shall stop transmitting. When the VTU-O observes the stopped transmission, it shall also stop transmitting.

11.2.3.9.2 L3 Request by VTU-O

Upon receipt of the L3 Request command, the responding VTU-R shall send either the Grant or Reject response. The proposed link state shall be formatted as 03₁₆ for the L3 link state. If any other link state is received, the Reject response shall be sent with the reason code 02₁₆.

The VTU-R may reject a request to move to link state L3 using reason code 01₁₆ because it is temporarily too busy, or reject it using code 03₁₆ because it has local knowledge that the L3 state is not desired at this time. Upon receipt of the L3 Request command, the VTU-R may immediately start the protocol to request a transition to the L3 state.

If the VTU-O receives the Grant response, the VTU-O shall stop transmitting. When the VTU-R observes the stopped transmission, it shall also stop transmitting.

11.2.3.10 Non-standard Facility commands and responses

The Non-standard Facility (NSF) commands may be used to exchange vendor-discretionary information between the VTUs. The NSF Request command is shown in Table 11-24 and may be initiated by either VTU to request the non-standard information. The responses shall be as shown in Table 11-25. The first octet of either the command or a response shall be the assigned value for the NSF command type, as shown in Table 11-4 for normal priority NSF commands, or in Table 11-5 for low priority NSF commands. The remaining octets of normal priority and low priority commands shall be as shown in Table 11-24. The second octet of normal priority and low priority responses shall be as shown in Table 11-25. The octets shall be sent using the format described in clause 11.2.3.1.

Table 11-24 – NSF commands sent by the requesting VTU

Name	Length (Octets)	Octet number	Content
Request	variable	2	01 ₁₆ (Note)
		3 to 8	6 octets of NSF identifier field
		9 +	multiple octets of NSF message field
NOTE – All other values for octet number 2 are reserved by ITU-T.			

Table 11-25 – NSF responses sent by the responding VTU

Name	Length (Octets)	Octet number	Content
ACK	2	2	80 ₁₆ (Note)
NACK	2	2	81 ₁₆ (Note)
NOTE – All other values for octet number 2 are reserved by ITU-T.			

Upon reception of the NSF Request command, the VTU shall respond with an acknowledgement (ACK) to indicate that both the NSF identifier field and the message field are recognized, or respond with a negative acknowledgement (NACK) if either the NSF identifier field or NSF message field is not recognized.

The combination of the NSF identifier field and NSF message field corresponds to a non-standard information block as defined in Figure 11 of [ITU-T G.994.1] (without the length-indicator octet). The NSF identifier field shall consist of 6 octets. The first 2 octets shall be a country code, and the remaining 4 octets shall be a provider code as specified by the country. Both values shall be set as defined in [ITU-T T.35]. The NSF message field contains vendor-specific information. The syntax of the NSF message field shall be as defined in Figure 11 of [ITU-T G.994.1] (without the length-indicator octet).

11.2.3.11 PMD Test Parameter Read commands and responses

The PMD Test Parameter Read commands shall be used to retrieve the values of the PMD test parameters that are specified in clause 11.4.1 and maintained by the far-end VTU. The PMD Test Parameter Read commands are shown in Table 11-26, and may be initiated by either VTU. The responses shall be as shown in Table 11-27. The first octet of all PMD Test Parameter Read commands and responses shall be the assigned value for the PMD Test Parameter Read command type, as shown in Table 11-5. The subsequent octets of the commands shall be as shown in Table 11-26. The subsequent octets of the responses shall be as shown in Table 11-27. The octets shall be sent using the format described in clause 11.2.3.1.

Table 11-26 – PMD test parameter read commands sent by the requesting VTU

Name	Length (octets)	Octet number	Content	Support
Single Read	2	2	01 ₁₆ (Note 1)	Mandatory
Next Multiple Read	2	2	03 ₁₆ (Note 1)	Mandatory
Multiple Read	4	2	04 ₁₆ (Note 1)	Mandatory
		3 to 4	2 octets describing the subcarrier group index	
Block Read	6	2	05 ₁₆ (Note 1)	Mandatory
		3 to 4	2 octets describing the start subcarrier group index	
		5 to 6	2 octets describing the stop subcarrier group index	

Table 11-26 – PMD test parameter read commands sent by the requesting VTU

Name	Length (octets)	Octet number	Content	Support
Vector Block Read	7	2	06 ₁₆ (Note 1)	Optional
		3	1 octet describing the type of test parameter to read (Note 2) 01 ₁₆ : Channel transfer function Hlog(<i>f</i>) per subcarrier group 03 ₁₆ : Quiet Line Noise PSD QLN(<i>f</i>) per subcarrier group 04 ₁₆ : Signal to noise ratio SNR(<i>f</i>) per subcarrier group.	
		4 to 5	2 octets describing the start subcarrier group index	
		6 to 7	2 octets describing the stop subcarrier group index	
Scalar Read	3	2	07 ₁₆ (Note 1)	Optional
		3	1 octet describing the type of scalar test parameters to be read (Note 2) 21 ₁₆ to 28 ₁₆ : the parameter index to read according to the ID of Table 11-28.	
NOTE 1 – All other values for octet number 2 are reserved by the ITU-T.				
NOTE 2 – All other values for octet number 3 are reserved by the ITU-T.				

Table 11-27 – PMD test parameter read responses sent by the responding VTU

Name	Length (octets)	Octet number	Content	Support
Single Read ACK	42 (Note 1)	2	81 ₁₆ (NOTE 2)	Mandatory
		3 to 42	Octets for the test parameters arranged for the single read format	
Multiple Read ACK	12 (Note 1)	2	82 ₁₆ (Note 2)	Mandatory
		3 to 12	Octets for the test parameters arranged for the multiple read format	
NACK	2	2	80 ₁₆ (Note 2)	Mandatory
Block Read ACK	Parameter-dependent (NOTE 1)	2	84 ₁₆ (Note 2)	Mandatory
		3 +	Octets for the test parameters arranged for the block read format	
Vector Block Read ACK	Parameter-dependent (Note 1)	2	86 ₁₆ (NOTE 2)	Optional
		3 +	Octets for the test parameters arranged for the block read format	
Scalar Read ACK	Parameter-dependent (Note 1)	2	87 ₁₆ (Note 2)	Optional
		3 +	Octets for the test parameters arranged for the scalar read format	
NOTE 1 – Message length equals 2 octets plus the length shown in Table 11-28.				
NOTE 2 – All other values for octet number 2 are reserved by the ITU-T.				

Table 11-28 – PMD test parameter ID values and length of responses

Test parameter ID (Note 1)	Test parameter name	Length for Single Read (octets)	Length for Multiple Read (octets)	Length for Block Read or Vector Block Read (octets)	Length for Scalar Read (octets)	Support
01 ₁₆	Channel transfer function Hlog(f) per subcarrier group	N/A	4	2 + (stop subcarrier group index – start subcarrier group index + 1) × 2 (Note 2)	N/A	Mandatory
03 ₁₆	Quiet line noise PSD QL _N (f) per subcarrier group	N/A	3	2 + (stop subcarrier group index – start subcarrier group index + 1) (Note 2)	N/A	Mandatory
04 ₁₆	Signal-to-noise ratio SNR(f) per subcarrier group	N/A	3	2 + (stop subcarrier group index – start subcarrier group index + 1) (Note 2)	N/A	Mandatory
21 ₁₆	Loop attenuation LATN	2 × 5	N/A	N/A	2 × 5	Mandatory
22 ₁₆	Signal attenuation SATN	2 × 5	N/A	N/A	2 × 5	Mandatory
23 ₁₆	Signal-to-noise ratio margin SNRM and SNRM-pb	2 × 6	N/A	N/A	2 × 6	Mandatory
24 ₁₆	Attainable net data rate ATTNDR (basic method)	4	N/A	N/A	4	Mandatory
24 ₁₆	Attainable net data rate ATTNDR (improved method)	8	N/A	N/A	8	Optional
25 ₁₆	Near-end actual aggregate transmit power ACTATP	2	N/A	N/A	2	Mandatory
26 ₁₆	Far-end actual aggregate transmit power ACTATP	2	N/A	N/A	2	Mandatory
27 ₁₆	Far-end actual impulse noise protection INP_act	N/A	N/A	N/A	2	Optional

Table 11-28 – PMD test parameter ID values and length of responses

Test parameter ID (Note 1)	Test parameter name	Length for Single Read (octets)	Length for Multiple Read (octets)	Length for Block Read or Vector Block Read (octets)	Length for Scalar Read (octets)	Support
28 ₁₆	Far-end actual signal-to-noise ratio margin for the robust overhead channel SNRM-ROC	N/A	N/A	N/A	2	Optional

NOTE 1 – All other Test parameter ID values are reserved by the ITU-T.

NOTE 2 – Since the number of subcarriers, G , in the subcarrier group (see clause 11.4.1) may be different for QLN, Hlog, and SNR, the values of QLN, Hlog and SNR communicated by Multiple Read, Block Read, or Vector Block Read for the same subcarrier group index may correspond to different subcarrier indices. The subcarrier index for each parameter equals $G \times \text{subcarrier_group_index}$, where the value of G is as defined in Table 11-42 of clause 11.4.1 (for showtime) and subcarrier group index = 0 to 511.

Upon reception of a PMD Test Parameter Read command, the responding VTU shall send the corresponding response. If the format of the Test Parameter Read command is incorrect, the VTU shall respond with the negative acknowledge (NACK). Any function of either the requesting or the responding VTU shall not be affected.

The Single Read command shall be used to retrieve all test parameters with ID values from 21₁₆ to 26₁₆ inclusive. In response to a Single Read command, the values for the test parameters (one value per parameter) shall be transferred in numerically increasing order of the parameter ID shown in Table 11-28. The format of the octets for each parameter shall be as specified in clause 11.4.1. Values formatted as multiple octets shall be mapped to the response in order of most significant to least significant octet. The LATN, SATN and SNRM format shall include five 2-octet values intended for 5 potentially available frequency bands for each transmission direction. The 2-octet values shall be sent in the order shown in Table 11-29. The value 00₁₆ shall be used to indicate the disabled bands. Octets indicated as reserved shall be set to ZERO in the transmitter and ignored by the receiver. The SNRM test parameter shall, in addition to all SNRM-pb values (clause 11.4.1.1.6.3), include the overall SNRM value (clause 11.4.1.1.6.2). The first 2-octet value is the overall SNRM, followed by the five 2-octet values of the SNRM-pb as specified in Table 11-29. For the ATTNDR, the use of either the basic or the improved method is configured during initialization (see clause 11.4.1.1.7). The ATTNDR test parameter is specified in Table 11-30.

Table 11-29 – Order for sending LATN, SATN and SNRM-pb parameters

Octet number	Upstream direction	Downstream direction
1	US0	DS1
2		
3	US1	DS2
4		
5	US2	DS3
6		

Table 11-29 – Order for sending LATN, SATN and SNRM-pb parameters

Octet number	Upstream direction	Downstream direction
7	US3	DS4
8		
9	US4	Reserved
10		

Table 11-30 – ATTNDR test parameter

Octet number	Basic method	Improved method
1-4	<i>ATTNDR</i>	<i>ATTNDR</i>
5	N/A	Reserved and set to 00 ₁₆
6	N/A	<i>ATTNDR_INP_act₀</i>
7	N/A	Reserved and set to 00 ₁₆
8	N/A	<i>ATTNDR_delay_act₀</i>
NOTE – The format of the fields is defined in clause 11.4.1.1.7.		

A Scalar Read command shall be used to retrieve a single test parameter. Support of this read command is optional. The ID of the test parameter to retrieve shall be indicated in the third octet of the read command as specified in Table 11-26. In response to a Scalar Read command, the VTU shall send the value of the test parameter if this command and the test parameter are supported by the VTU; otherwise the VTU shall send a NACK. The format of the octets for each parameter value shall be as described in clause 11.4.1. Values formatted as multiple octets shall be mapped to the response in order of most significant to least significant octet. The format of the LATN, SATN, SNRM and ATTNDR shall be identical to the format used in Single Read Command. The Far-end actual impulse noise protection (ID=27₁₆) shall include two 1-octet values and be sent in the order shown in Table 11-31. The value FF₁₆ shall be used to indicate the disabled bearers.

Table 11-31 – Order for sending far-end actual impulse noise protection parameters

Octet number	Parameter
1	INP_act for bearer channel 0
2	INP_act for bearer channel 1

Multiple Read and Next Multiple Read commands shall be used to retrieve test parameters of one subcarrier group. In response to a Multiple Read or Next Multiple Read command, the VTU shall send information for test parameters with ID 01₁₆, 03₁₆, and 04₁₆ associated with the indicated subcarrier group. The Multiple Read command contains the index of the requested subcarrier group (see Table 11-26). If a Next Multiple Read command is to be sent, it shall only be sent after a Multiple Read command. In response to each subsequent Next Multiple Read command, the subcarrier group index shall be incremented by one. If the subcarrier group index exceeds 511 (see clause 11.4.1), the response shall be a NACK. The values of the PMD parameters per subcarrier group shall be inserted into the message in numerical order of the parameter ID shown in Table 11-28. The format of the

octets for each parameter shall be as described in clause 11.4.1. Values that are formatted as multiple octets shall be mapped to the response in order of most significant to least significant octet.

A Block Read command shall be used to retrieve test parameters over a range of subcarrier groups. In response to a Block Read command, the VTU shall send information for test parameters with ID 01_{16} , 03_{16} , and 04_{16} associated with the specified block of subcarrier groups. For test parameters specified per subcarrier group, all values for subcarrier groups with indices from #start to #stop are transferred in a single response. If the subcarrier group index exceeds 511, the response shall be a NACK. The values of the PMD parameters per subcarrier group shall be inserted into the message in increasing order of the parameter ID shown in Table 11-28. The format of the octets for each parameter value shall be as described in clause 11.4.1. Values formatted as multiple octets shall be mapped to the response in order of most significant to least significant octet. The number of octets in a Block Read command shall not exceed the maximum length P of the eoc message specified in clause 11.2.3.1.

A Vector Block Read command shall be used to retrieve a single test parameter over a range of subcarrier groups. Support of this read command is optional. The ID of the test parameter to retrieve shall be indicated in the third octet of the read command as specified in Table 11-26. In response to a Vector Block Read command, the VTU shall send information for the test parameter associated with the specified block of subcarrier groups if this command is supported by the VTU; otherwise the VTU shall send a NACK. All values for subcarrier groups with indices from #start to #stop are transferred in a single response. If the subcarrier group index exceeds 511, the response shall be a NACK. The format of the octets for each parameter value shall be as described in clause 11.4.1. Values formatted as multiple octets shall be mapped to the response in order of most significant to least significant octet.

When transferring values of the channel transfer function $Hlog(f)$, the quiet line noise $QLN(f)$, and the signal-to-noise ratio $SNR(f)$, the measurement time shall be included in the response for each test parameter. The ACK (see Table 11-27) is followed by the $HLOG(f)$ measurement time and the value m (see clause 11.4.1.1.1), followed by the $QLN(f)$ measurement time and value n (see clause 11.4.1.1.2), followed by the $SNR(f)$ measurement time and value SNR (see clause 11.4.1.1.3), respectively. The measurement time shall be included only once in a response to a Block Read or Vector Block Read command, and shall be included for each test parameter in each response to a Multiple Read or Next Multiple Read command.

The values of some test parameters are represented using fewer bits than contained in the corresponding field defined for the response in Table 11-28. In the case that the field has more than one octet, the bits shall be mapped to the LSBs of the multi-octet field in the response. Unused MSBs in the multi-octet field shall be set to ZERO for unsigned quantities and to the value of the sign bit for signed quantities.

11.2.3.12 Control Parameter Read commands and responses

Control parameter read commands are for further study.

11.2.3.13 INM facility commands and responses

A VTU that supports the INM facility shall maintain INM counters to measure the impulse noise, as described in [ITU-T G.997.1]. The INM facility commands shall be used to update and read the INM parameters at the VTU-R.

The INM facility command shall be used also to retrieve the current value of the INM counters maintained by the far-end VTU in accordance with [ITU-T G.997.1].

The INM facility commands are described in Table 11-32, and may only be initiated by the VTU-O. The VTU-R shall reply using one of the responses shown in Table 11-33. The first octet of all INM facility commands and responses shall be the assigned value for the INM facility command type, as shown in Table 11-5. The remaining octets shall be as specified in Table 11-32 and Table 11-33 for

commands and responses, respectively. The octets shall be sent using the format described in clause 11.2.3.1.

Table 11-32 – INM facility commands sent by the VTU-O

Name	Length (Octets)	Octet number	Content
Read INM counters	2	2	02 ₁₆
Set INM parameters	6 or 7	2	03 ₁₆
		3 to 6 or 7	4 or 5 octets of INM parameters: see Table 11-36
Read INM parameters	2	2	04 ₁₆
All other values for octet number 2 are reserved by ITU-T.			

Table 11-33 – INM facility responses sent by the VTU-R

Name	Length (Octets)	Octet number	Content
ACK	3	2	80 ₁₆
		3	1 octet INM acceptance code: see Table 11-34
NACK	2	2	81 ₁₆
INM counters	107	2	82 ₁₆
		3 to 2 + 4 × (17+1+8)	Octets for all of the INM counter values: see Table 11-35
		107	1 octet INMDF
INM parameters	6 or 7	2	84 ₁₆
		3 to 6 or 7	4 or 5 octets of INM parameters: see Table 11-36
All other values for octet number 2 are reserved by ITU-T.			

Upon reception of any INM facility command, the VTU-R shall send NACK in response if it does not support the INM procedure or the INM command is invalid. Upon reception of an INM facility set INM parameters command, the VTU-R shall send the ACK in response if it does support the INM procedure.

In case all INM parameter values listed in the set INM parameters command are valid and supported by the VTU-R, the VTU-R shall accept all of the INM parameters contained in the command. The INM acceptance code (see Table 11-34) will indicate that the parameters are accepted. If, for any of the INM parameters, the value in the command is different from the value in active use by the INM, the VTU-R shall activate the new INM parameter values and reset the counters less than 1 second after sending the ACK.

In case any INM parameter values listed in the set INM parameters command is valid but not supported by the VTU-R, the VTU-R shall not accept any of the INM parameters and shall not reset the counters.

Upon reception of the INM facility read INM parameters command, the VTU-R shall send the INM parameters response that includes the current value of the VTU-R INM parameters.

Table 11-34 – VTU-R INM acceptance code

Name	Octet No.	Content
ACC-INM_INPEQ_MODE	3	80 ₁₆ : value for INM_INPEQ_MODE accepted
NACC-INM_INPEQ_MODE	3	81 ₁₆ : value for INM_INPEQ_MODE not supported

Upon reception of the INM facility read INM counters command, the VTU shall send the INM counters response, which includes the INMDF. Any function of either the requesting or the responding VTU shall not be affected by this command.

The INM counter values shall be derived according to [ITU-T G.997.1] from locally generated defects and anomalies defined in clause 11.3. The parameters shall be transferred in the order (top to bottom) defined in Table 11-35. All counter values are defined as 32-bit counters and shall be mapped to the response in order of most significant to least significant octet.

The INM counters shall be reset at power-up, and shall not be reset upon any link state transition, and shall not be reset upon read. They shall be reset at activation of the new INM parameter values. The reset value is zero. The INM counters and the procedure to update the counters shall work continuously and independently of other (proprietary or non-proprietary) features, e.g., the INM shall work in the presence of OLR and without interruption.

NOTE – The VTU-O should respond to the request from the NMS to read the values of INM counters. It is left to the implementations to store and update the counters as necessary for accurate monitoring and reporting.

Table 11-35 – VTU-R INM counters

INM counters
Counter of the INMAINPEQ ₁ anomalies
Counter of the INMAINPEQ ₂ anomalies
...
Counter of the INMAINPEQ ₁₆ anomalies
Counter of the INMAINPEQ ₁₇ anomalies
Counter of the INMAIAT ₀ anomalies
Counter of the INMAIAT ₁ anomalies
...
Counter of the INMAIAT ₆ anomalies
Counter of the INMAIAT ₇ anomalies
Counter of the INMAME anomalies

The VTU-R shall set the INM default flag (INMDF) to ONE whenever all active INM parameters are equal to the default values. The VTU-R shall set the INM default flag (INMDF) to ZERO whenever any active INM parameter is different from the default value.

The INM parameter values shall be transferred in the order defined in Table 11-36 and mapped in order of most significant to least significant octet.

Table 11-36 – VTU-R INM parameters

Octet No.	INM parameter
3-4	2 octets: <ul style="list-style-type: none"> The 9 LSBs are INMIATO The 4 MSBs are INMIATS
5	1 octet: INMCC
6	1 octet: INM_INPEQ_MODE
7	1 octet: INM_INPEQ_FORMAT This octet is present only if supported by both VTU-O and VTU-R (see Tables 12-49 and 12-60).

11.2.3.14 Frequency Synchronization command

The VTU-O shall be capable of sending frequency synchronization command through the eoc if this mechanism is selected during initialization. The command is only in one direction, from VTU-O to VTU-R, and there is no response required.

The ToD phase difference value and corresponding t_1 event number shall be encapsulated in an *eoc* message as follows:

Table 11-37 – Frequency Synchronization command sent by the VTU-O

Name	Length (Octets)	Octet number	Content
ToD phase difference	5	2	03 ₁₆ (Note)
		3	1 octet representing the index of the t_1 event
		4 to 5	2 octets representing the ToD phase difference in units of 2 nanoseconds
NOTE – All other values for octet number 2 are reserved by ITU-T.			

If the VTU-R selects during initialization that the ToD phase difference values shall be transported through the eoc, then the VTU-O shall generate a ToD phase difference eoc message into the nearly-high priority queue for each super-frame. For each super-frame, the VTU-O shall send the most recent phase difference eoc message in the queue and shall discard older phase difference eoc messages. If the VTU-R selects during initialization to transport the ToD phase difference values through the OH frame, then the VTU-O shall not send phase difference eoc messages.

11.2.3.15 Time Synchronization command and responses

The VTU shall be capable of sending and receiving the Time Synchronization commands and responses listed in Table 11-38 (command sent by VTU-O) and Table 11-39 (response sent by VTU-R), respectively. The Timestamp command specified in Table 11-38 shall only be sent by the VTU-O. The Timestamp response specified in Table 11-39 shall only be sent by the VTU-R. The VTU-R may reject to run time synchronization procedure using responses listed in Table 11-39 with reason codes listed in Table 11-40, or positively acknowledge by transmitting an ACK response.

The first octet of all Time Synchronization commands and responses shall be the assigned value for the Time Synchronization command type, as shown in Table 11-4. The remaining octets shall be as shown in Tables 11-38 and 11-39. The octets of the Time Synchronization commands and responses shall be set over the link as described in clause 11.2.3.1.

Table 11-38 – Time Synchronization commands sent by the VTU-O

Name	Length (Octets)	Octet number	Content
ToD(t_1) ToD(t_4) Timestamps	26	2	01 ₁₆ (Note 1)
		3 to 4	2 octet for the index of time stamp ToD(t_1) in units of a super-frame.
		5 to 10	6 octets describing the integer portion of the timestamp ToD(t_1) in units of seconds.
		11 to 14	4 octets describing the fractional portion of the timestamp ToD(t_1) in units of nanoseconds. (Note 2)
		15 to 16	2 octets for the index of time stamp ToD(t_4) in units of a superframe.
		17 to 22	6 octets describing the integer portion of the timestamp ToD(t_4) in units of seconds.
		23 to 26	4 octets describing the fractional portion of the timestamp ToD(t_4) in units of nanoseconds. (Note 2)
NOTE 1 – All other values for octet number 2 are reserved by ITU-T.			
NOTE 2 – The nanosecond portion is always less than 10 ⁹ .			

The octets for the index of time stamp ToD(t_1) contain the value of the downstream super-frame counter when ToD(t_1) is taken by the VTU-O (i.e., at the t_1 event). This value shall be a multiple of 16. The octets for the index of time stamp ToD(t_4) contain the value of the upstream super-frame counter when ToD(t_4) is taken by the VTU-O (i.e., at t_4 event). The difference between the downstream super-frame counter at t_1 event and the upstream superframe counter at t_4 event shall be constant over Showtime (i.e., the pairing of the t_1 and t_4 events shall not change over Showtime). The t_1 event and the t_4 event shall be less than 1 superframe apart (i.e., 64.25 ms on the PMD sampling clock timebase if the CE length corresponds to $m = 5$, see clause 10.4.4). The ToD(t_1), ToD(t_2), ToD(t_3), and ToD(t_4) time stamps are described as two parts. One is the integer portion of the timestamp in units of seconds and the other is the fractional portion of the timestamp in units of nanoseconds. The ToD(t_1), and ToD(t_4) time stamps shall represent the time offset between the current time of the Real-time Clock RTC-O at the VTU-O (i.e., the time elapsed since the epoch) at the t_1 and t_4 events respectively. The ToD(t_2), and ToD(t_3) timestamps shall represent the time of the Real-time Clock RTC-R at the VTU-R, (i.e., the time elapsed since the epoch) at the t_2 and t_3 events respectively. The epoch shall be the same for the Real-time Clock RTC-O and the Real-time Clock RTC-R, where this common epoch is set over the γ -O reference point.

NOTE – If at the t_1 event the Real-time Clock RTC-O shows +2.000000001 seconds have elapsed since the epoch, this is represented in the ToD(t_1) timestamp by seconds = 0x0000 0000 0002 and nanoseconds = 0x0000 0001. The epoch may be locally set by the DSLAM or may be an absolute instant in time. For example, if the epoch is the PTP epoch, this means that time-of-day = 1 January 1970 00:00:02.000000001.

Table 11-39 – Time Synchronization responses sent by the VTU-R

Name	Length (Octets)	Octet number	Content
ToD(t_2) ToD(t_3) Timestamps (ACK)	26	2	81 ₁₆ (Note 1)
		3 to 4	2 octets for the index of t_2 time stamp.
		5 to 10	6 octets describing the integer portion of the timestamp in units of seconds.
		11 to 14	4 octets describing the fractional portion of the timestamp in units of nanoseconds. (Note 2)
		15 to 16	2 octets for the index of t_3 time stamp.
		17 to 22	6 octets describing the integer portion of the timestamp in units of seconds.
		23 to 26	4 octets describing the fractional portion of the timestamp in units of nanoseconds. (Note 2)
Reject	3	2	82 ₁₆ (Note 1)
		1	1 octet for reason code (see Table 11-40)
NOTE 1 – All other values for octet number 2 are reserved by ITU-T.			
NOTE 2 – The nanosecond portion is always less than 10 ⁹ .			

Table 11-40 – Reason codes for Time Synchronization responses

Reason	Octet value
Busy	01 ₁₆
Invalid parameters	02 ₁₆
t_2 and t_3 timestamps no longer available at the VTU-R	03 ₁₆
Still acquiring ToD frequency synchronization	04 ₁₆

The Timestamp command is used to send time stamps ToD(t_1) and ToD(t_4) from the VTU-O to the VTU-R. Upon reception of a Timestamp command, the VTU-R shall either send the time stamps ToD(t_2) and ToD(t_3) in an ACK response to indicate that the time synchronization procedure will be performed with the ToD(t_1), ToD(t_2), ToD(t_3) and ToD(t_4) timestamps, or send a reject response with a reason code from those specified in Table 11-40.

The VTU-R shall store the t_2 (and related t_3) values for at least the three most recent downstream (and related upstream) reference samples with a t_2 event count that is a multiple of 16. The VTU-O should send the time synchronization command soon enough after the t_1 and t_4 events to assure the related t_2 and t_3 timestamps are still available at the VTU-R.

If the VTU-R accepts the Timestamp command, the Timestamp response is used to send timestamps ToD(t_2), and ToD(t_3) from the VTU-R to the VTU-O. The ToD(t_1), ToD(t_2), ToD(t_3) and ToD(t_4) timestamps (in conjunction with other information) may be used at the network side to e.g., compensate for propagation delay asymmetry. At the customer premises side, propagation delay asymmetry shall not be compensated for. Other uses of the response reported time stamp values at the network side are for further study.

11.2.3.16 Data gathering commands and responses

This clause defines the commands and responses to support the data gathering function defined in clause 11.5. If the VTU-R supports the data gathering function, then the VTU-R shall keep a buffer of data gathering records, with each data gathering record relating to one of the event types listed in Table 11-43. Data gathering records shall be transmitted from the VTU-R to the VTU-O in eoc messages upon request of the VTU-O. The VTU-O sends a data gathering command (to configure data gathering or to request a number of data gathering records, see Table 11-40.1). The VTU-R shall respond with a data gathering response (to ACK/NACK the data gathering configuration or to transfer data gathering records, see Table 11-40.2). The VTU-O shall acknowledge (ACK) the response and may simultaneously request more data gathering records. The VTU-R buffer shall be transferred to the VTU-O through a sequence of command and response messages until all records in the VTU-R buffer, up to *act_logging_depth_reporting_R* records, are reported.

Table 11-40.1 – Data gathering commands sent by the VTU-O

Name	Length (Octets)	Octet number	Content
Configure data gathering		2	00 ₁₆
		3-4	<i>act_logging_depth_reporting_R</i>
		5	<i>logging_reporting_newer_first</i>
		6	number of event types configured (<i>Ntyp</i>)
		7	<i>logging_depth_event_percentage_R_1</i>
	
		7+ <i>Ntyp</i>	<i>logging_depth_event_percentage_R_Ntyp</i>
Request data gathering records	1	2	01 ₁₆
	1	3	ACK_ID
	1	4	Sequence_ID
	1	5	Number of event records to report in response message (<i>Nreq</i>)

Table 11-40.2 – Data gathering response sent by the VTU-R

Name	Length (Octets)	Octet number	Content
Configure data gathering ACK	4	4 5-6	80 ₁₆ <i>logging_depth_R</i>
Configure data gathering NACK	4	4 5-6	81 ₁₆ <i>logging_depth_R</i>

Table 11-40.2 – Data gathering response sent by the VTU-R

Name	Length (Octets)	Octet number	Content
Response with data gathering records	10 (if $Nrep=0$) up to 778 (if $Nrep=128$)	2	90 ₁₆
		3	Sequence_ID
		4-7	Current VTU-R timestamp
		8-9	Number of event records in the buffer not yet ACKed ($Nnack$)
		10	Number of event records reported in this message ($Nrep$)
		11 ... 10+6× $Nrep$	6× $Nrep$ octets with the data gathering records

11.2.3.16.1 Data gathering configuration

The control parameter *act_logging_depth_reporting_R* is defined in clause 11.5. The control parameter *logging_report_newer_first* indicates the order in which the VTU-R shall report the records in the VTU-R buffer. If set to TRUE, then the VTU-R shall report the record related to the most recent event first. If set to FALSE, then the VTU-R shall report the record related to the least recent event first. The control parameter *logging_report_newer_first* shall have a value equal to the CO-MIB configuration parameter LOGGING_REPORT_NEWER_FIRST (see clause 7.3.6.5 of [ITU-T G.997.1]).

The control parameters *logging_depth_event_percentage_R_i* are defined in clause 11.5. The *logging_depth_event_percentage_R_i* is configured for event type ID = 1 up to event type ID = *Ntyp*, with event type IDs as listed in Table 11-43. For all event types with ID > *Ntyp*, the VTU-R shall set *logging_depth_event_percentage_R_i* = 0.

If the VTU-R supports the last received data gathering configuration, then the VTU-R shall send a configure data gathering ACK response. If the VTU-R does not support the last received data gathering configuration (e.g., because *act_logging_depth_reporting_R* is higher than *logging_depth_R*), then the VTU-R shall send a configure data gathering NACK response. Upon sending an ACK, the VTU-R shall apply the last received data gathering configuration. Upon receiving a NACK, the VTU-O shall send a new configure data gathering command.

If a new data gathering configuration is applied with an *act_logging_depth_reporting_R* larger than or equal to the actual number of records in the VTU-R buffer, then existing records shall stay in the VTU-R buffer. Otherwise, the VTU-R may apply a vendor discretionary method (including reset of the entire VTU-R buffer) to discard records in the buffer.

If a new data gathering configuration is applied with an *act_logging_depth_reporting_O* larger than or equal to the actual number of records in the VTU-O buffer, then existing records shall stay in the VTU-O buffer. Otherwise, the VTU-O may apply a vendor discretionary method (including reset of the entire VTU-O buffer) to discard records in the buffer.

11.2.3.16.2 Transfer of the VTU-R buffer from the VTU-R to the VTU-O

The VTU-R buffer is transferred to the VTU-O through a sequence of command and response messages until all records in the VTU-R buffer, up to *act_logging_depth_reporting_R* records, are reported.

The VTU-O allocates a sequence ID to each request data gathering records command message. The first command message in a sequence of command and response messages shall have Sequence_ID = 00₁₆. If the response message to a command message is received by the VTU-O, then

the next command message shall have the `Sequence_ID` incremented by one. If the response message to a command message is not received, then the next command message shall be a retransmission of the previous command message or a command message with `sequence_ID = 0016`. If a sequence of more than 128 command and response messages is needed to transfer the whole VTU-R buffer, then the `sequence_ID` following `sequence_ID = 7F16` shall be `sequence_ID = 0116`.

In the response with data gathering records message, the VTU-R shall copy the same `sequence_ID` allocated by the VTU-O to the request data gathering records command message.

In the command message with `Sequence_ID = 0016`, the VTU-O shall set the `ACK_ID` to `0016`.

When receiving a command message with `Sequence_ID = 0016`, the VTU-R shall ignore the `ACK_ID` in this command message. Before sending a response message, the VTU-R shall mark all records in the VTU-R buffer (except dummy records) as "not yet ACKed". In the response message (with `Sequence_ID = 0016`), the value *Nnack* indicate the number of records in the VTU-R buffer. With a VTU-R buffer full condition, *Nnack* = *act_logging_depth_reporting_R*.

When receiving a command message with `Sequence_ID > 0016`, and before sending a response message, the VTU-R shall mark the set of records which were reported in the response message with `sequence_ID` equal to *ACK_ID* as having been ACKed. The VTU-R shall keep the ACKed records in the VTU-R buffer (i.e., not delete the ACKed records from the VTU-R buffer).

NOTE 1 – The records are not marked as ACKed until the `ACK_ID` is received because eoc messages (requests or responses) can get lost.

The command message shall include the number of records requested to be reported (*Nreq*). The value of *Nreq* shall be at most 128. If the VTU-O chooses to use multiple eoc command/response messages to transfer the whole VTU-R buffer, then the value of *Nreq* may be less than *act_logging_depth_reporting_R*.

The response message shall include the number of records stored in the VTU-R buffer that are not yet ACKed by the VTU-O (*Nnack*), so the VTU-O knows how many more records are to be transferred.

The response message shall include the number of records reported in the response message (*Nrep*). The value *Nrep* shall be the minimum of *Nreq* and *Nnack*. If *Nrep* < *Nreq*, then *Nrep* = *Nnack*. If all records in the VTU-R buffer have been ACKed, then *Nrep* = *Nnack* = 0.

If *logging_report_newer_first* is FALSE, then the response message shall include the *Nrep* least recent records in the VTU-R buffer that have not yet been ACKed by the VTU-O. The response message shall include the *Nrep* records in ascending order of timestamp, with the least recent record starting at octet 11.

If *logging_report_newer_first* is TRUE, then the response message with `sequence_ID = 0` shall include the *Nrep* most recent records in the VTU-R buffer that have not yet been ACKed by the VTU-O. The response messages with `sequence_ID > 0` shall include the *Nrep* most recent records in the VTU-R buffer that have not yet been ACKed by the VTU-O and have a timestamp older than the timestamps of the records ACKed by the VTU-O in the command message. The response message shall include the *Nrep* records in descending order of timestamp, with most recent record starting at octet 11.

The response message includes the current VTU-R timestamp. This allows the VTU-O to offset all the VTU-R timestamps with a fixed offset so that they are stored in the CO-MIB in the same NTP format, with nearly the same timing, as the VTU-O timestamps. This also limits the time error due to VTU-R clock drift to the accumulated error between the time the event is recorded and the time that it is transferred to the VTU-O.

Upon receiving the response message containing the last of *act_logging_depth_reporting_R* records to be transferred, or upon receiving a response message with *Nnack* = *Nrep*, the VTU-O shall send

the last command message in the sequence of command and response messages that is an acknowledgement of the last transferred *Nrep* records, and has *Nreq* = 0, denoting no further records are to be transferred. Only in this last command message in a sequence of command and response messages shall *Nreq* = 0. All preceding command messages shall have *Nreq* > 0.

NOTE 2 – If no new records are generated at the VTU-R during the eoc transfer, then the entire VTU-R buffer is transferred to the VTU-O.

NOTE 3 – If new event records are generated at the VTU-R during the eoc transfer, leading to already transferred records being removed from the VTU-R buffer due to buffer management rules, and *logging_report_newer_first* is FALSE, then the VTU-R buffer will not be entirely transferred to the VTU-O because *act_logging_depth_reporting_R* records will have been ACKed by the VTU-O while *Nnack* is still larger than zero at the VTU-R.

NOTE 4 – If new event records are generated at the VTU-R during the eoc transfer, leading to not yet transferred records being removed from the VTU-R buffer due to buffer management rules, and *logging_report_newer_first* is TRUE, then the VTU-R buffer will not be entirely transferred to the VTU-O because *Nnack* will be zero at the VTU-R before *act_logging_depth_reporting_R* records have been ACKed by the VTU-O.

11.2.3.16.3 Write of the transferred VTU-R buffer to the CO-MIB

If *logging_report_newer_first* is TRUE, then (see notes 3, 4 and 5 below):

- When the VTU-O sends a data gathering command message with *sequence_ID* = 00₁₆, the VTU-O shall reset the *EVENT_TRACE_BUFFER_R* to all zero values by setting all records to be dummy records, where a dummy record is defined as a record which has all fields set to the value 0.
- The VTU-O shall write the block of records contained in the data gathering response message with *Sequence_ID* = 00₁₆ in the *EVENT_TRACE_BUFFER_R* in the locations corresponding to the most recent block of records.
- The VTU-O shall write blocks of records contained in subsequent data gathering response messages in the *EVENT_TRACE_BUFFER_R* in the locations corresponding to the next most recent block of records.
- The VTU-O may choose to update the *EVENT_TRACE_BUFFER_R* with every received data gathering response message, or may choose to update after having received several data gathering response messages.

NOTE 1 – Subsequent readings of the *EVENT_TRACE_BUFFER_R* over the Q-interface while a transfer of the VTU-R buffer is ongoing may show a steadily increasing number of records in the CO-MIB element.

- The order of the records in the *EVENT_TRACE_BUFFER_R* shall correspond to the order of the records inside a received data gathering response message (i.e., no reordering inside a block), and concatenated in the order of subsequently received data gathering response messages (i.e., no reordering of blocks).

If *logging_report_newer_first* is FALSE, then (see notes 4 and 5 below):

- Then the VTU-O sends a data gathering command with *sequence_ID* = 00₁₆, then the *EVENT_TRACE_BUFFER_R* is not reset.
- The VTU-O shall write the block of records contained in the data gathering response message with *Sequence_ID* = 00₁₆ in the *EVENT_TRACE_BUFFER_R* in the locations corresponding to the least recent block of records and thereby overwrite the existing records at those locations.
- The VTU-O shall write blocks of records contained in subsequent data gathering response messages in the *EVENT_TRACE_BUFFER_R* in the locations corresponding to the next least recent block of records and thereby overwrite the existing records at those locations.

- The VTU-O may choose to update the EVENT_TRACE_BUFFER_R with every received data gathering response message, or may choose to update after having received several data gathering response messages.

NOTE 2 – Subsequent readings of the EVENT_TRACE_BUFFER_R over the Q-interface while a transfer of the VTU-R buffer is ongoing may show some duplicate records.

- The order of the records in the EVENT_TRACE_BUFFER_R shall correspond to the order of the records inside a received data gathering response message (i.e., no reordering inside a block), and concatenated in the order of subsequently received data gathering response messages (i.e., no reordering of blocks).

NOTE 3 – Setting *logging_report_newer_first* to TRUE allows the rapid transfer of a relatively small number of recent event records with a relatively small number of data gathering commands.

NOTE 4 – If no new event records are generated at the VTU-R during the transfer of the VTU-R buffer, then the entire VTU-R buffer is transferred into EVENT_TRACE_BUFFER_R.

NOTE 5 – If new records are generated at the VTU-R during the transfer of the VTU-R buffer, then the CO-MIB parameter EVENT_TRACE_BUFFER_R may not contain some records that are present in the VTU-R buffer at the end of the transfer, may not contain some records that were present in the VTU-R buffer at the start of the transfer, and may contain records that are not present in the VTU-R buffer at the end of the transfer because of buffer management.

11.2.3.17 SAVN-Update command and responses

The VTU-O shall send the SAVN-Update command to communicate the updated value of the downstream transmitter referred showtime adaptive virtual noise (TXREFSAVNds) to the VTU-R. Upon reception of the SAVN-Update command, the VTU-R shall send a SAVN-Update response.

The first octet of both the command and the response indicates the SAVN-Update command type, as defined in Table 11-4 (normal priority). The other octets of the SAVN-Update command are defined in Table 11-40.3. The SAVN-Update response shall be a simple acknowledgement that indicates the serial number of the update, as defined in Table 11-40.4. The SAVN-Update command shall be initiated by the VTU-O only. The SAVN-Update response shall be sent by the VTU-R only.

Table 11-40.3 – SAVN-Update command (sent by the VTU-O)

Name	Length (Octets)	Octet number	Content
SAVN-Update	7+(stop sub-carrier group index – start sub-carrier group index + 1)	2	09 ₁₆ (Note 1)
		3	One octet containing the sequence number of the update (Note 2)
		4 to 5	2 octets describing the start subcarrier group index
		6 to 7	2 octets describing the stop subcarrier group index
		8 to 7+(stop subcarrier group index – start subcarrier group index + 1)	The transmitter-referred SAVN PSD, TXREFSAVNds

NOTE 1 – All other values for octet numbers 2 are reserved by ITU-T.

NOTE 2 – The sequence number of the update shall be "1" for the first SAVN-Update command, and shall be incremented by 1 for each subsequent SAVN-Update command, wrapping around to "0" after "255".

TXREFSAVNds indicates the PSD of the SAVN that shall be taken into account when determining bit loading and active tone set using SNRM_MODE = 5 (see clause 11.4.1.1.6.1.5). In case SAVN is

not used, both the start subcarrier group index and the stop subcarrier group index shall be equal to 0 and the TXREFSAVNds field shall be of zero length.

TXREFSAVNds($k \times G \times \Delta f$) shall be the value of the transmitter referred SAVN PSD for subcarriers with indices from $k \times G$ to $((k+1) \times G) - 1$, inclusive. It shall be represented as an 8 bit unsigned integer $savn(k)$, where $k = 0$ to 511. The value of TXREFSAVNds($k \times G \times \Delta f$) shall be defined as $TXREFSAVNds(k \times G \times \Delta f) = -23 - (savn(k)/2)$ dBm/Hz. This data format supports a TXREFSAVNds(f) granularity of 0.5 dB with a valid range of values for TXREFSAVNds(f) from -150 (coded 254) to -23 (coded 0) dBm/Hz. The value coded 255 is reserved for future use by ITU-T. The group size for TXREFSAVNds shall be $G = 8$.

Table 11-40.4 – SAVN-Update response (sent by the VTU-R)

Name	Length (Octets)	Octet number	Content
SAVN-ACK	4	2	0A ₁₆ (Note 1)
		3	One octet containing the sequence number of the acknowledged SAVN-Update command
		4	One octet indicating whether or not an SRA will follow (Note 1): 00 ₁₆ SRA will follow 01 ₁₆ No SRA will follow
SAVN-NACK	3	2	0B ₁₆ (Note 1)
		3	Reason code (Note 1): 00 ₁₆ Invalid parameter set 01 ₁₆ Violation of initialization policy
NOTE 1 – All other values for this octet are reserved by ITU-T.			

The VTU-R shall compute the bit loading and framing parameters corresponding to the updated value of the TXREFSAVNds. The updated value of TXREFSAVNds may require a modification of the bit loading, or framing parameters, or both, with the aim of maintaining operation of the line within the boundaries set at initialization (e.g., SNRM boundaries). If no modification of the bit loading, or framing parameters is required, then the VTU-R shall reply with the SAVN-ACK response, indicating no SRA will follow. If modification of the bit loading or framing parameters is required and the required modification of the bit loading or framing parameters is within the boundaries set at initialization (e.g., related to ETR), then the VTU-R shall reply with the SAVN-ACK response indicating an SRA will follow and shall initiate an SRA (Request Type 3 for ITU-T G.993.2 and Request Type 5 for ITU-T G.998.4) within 1 second after sending the SAVN-ACK response. If the required modification cannot be made within the boundaries set at initialization (e.g., related to ETR), then the VTU-R shall reply with the SAVN-NACK response using a reason code 01₁₆, which means that the requested SAVN PSD cannot be applied within the initialization policy.

Upon receiving a SAVN-NACK response, the VTU-O may either send another SAVN PSD update or re-initialize the line with new boundaries for performance parameters, which can fit the required SAVN settings.

VTU-O shall not send SAVN-Update command when the VTU-R is involved in an OLR procedure associated with change of the bit loading or framing parameters in the downstream direction.

11.2.4 Indicator bits (IB)

The IB are used to send the far-end anomalies and defects specified in Table 11-41. Sending IB is mandatory, both upstream and downstream. The IB shall be set to ZERO if in the active state. Mapping of the IB to the overhead channel shall be as specified in clause 9.5.2.2.

Table 11-41 – Content of IB

IB	Description	Reference
<i>los</i>	Loss of signal defect	See clause 11.3.1.3
<i>rdi</i>	Remote defect indication defect	See clause 11.3.1.4
<i>lpr</i>	Loss of power primitive	See clause 11.3.3.1
TIB#0-1 to TIB#0-4	Four indicator bits reserved for the TPS-TC serving bearer #0	See Annex L
TIB#1-1 to TIB#1-4	Four indicator bits reserved for the TPS-TC serving bearer #1	See Annex L

11.3 OAM primitives

Among the standard OAM primitives, this Recommendation specifies only anomalies and defects. The system shall use the corresponding failure specifications of [ITU-T G.997.1].

Both the near-end and the far-end primitives shall be represented at the VTU-O; representation of the far-end anomalies and defects at the VTU-R is optional.

OAM primitives shall not be generated for the overhead-only latency path (ROC).

11.3.1 Line-related primitives

Line-related primitives represent anomalies and defects related to PMD and PMS-TC sublayers.

11.3.1.1 Near-end anomalies

- Forward error correction (*fec-p*): This anomaly occurs when a received FEC codeword in the latency path #*p* indicates that errors have been corrected. This anomaly is not asserted if errors are detected and are not correctable.
- Cyclic redundancy check (*crc-p*): This anomaly occurs when a received CRC byte for the latency path #*p* is not identical to the corresponding locally generated CRC byte.
- Rate adaptation upshift (*rau*): For further study.
- Rate adaptation downshift (*rad*): For further study.
- Loss-of-power interruption (*lpr_intrpt*): Excluding re-initializations triggered by the VTU-O host, this anomaly occurs when the time between the exit from Showtime of the VTU-O and first successful reception of an ITU-T G.994.1 message is less than 120 seconds and at least one of the following conditions is met: an LPR-FE (see clause 7.1.1.2.3 of [ITU-T G.997.1]) is declared before the exit from Showtime or the PLPR flag is set at the entry into Showtime. This anomaly is only defined at the VTU-O.
- Host-Reinit interruption (*hri_intrpt*): Excluding re-initializations triggered by the VTU-O host, this anomaly occurs when the PHRI flag is set at the entry into Showtime. This anomaly is only defined at the VTU-O.
- Spontaneous interruption (*spont_intrpt*): Excluding re-initializations triggered by the VTU-O host, this anomaly occurs when the time between the exit from Showtime of the VTU-O and the first successful reception of an ITU-T G.994.1 message is less than 120 seconds and

neither an *lpr_intrpt* nor a *hri_intrpt* occurs, and the VTU-R supports the initialization flags request and the initialization flags reset request commands.

This anomaly is only defined at the VTU-O.

11.3.1.2 Far-end anomalies

- Far-end forward error correction (*ffec-p*): This anomaly occurs when an *fec-p* anomaly detected at the far end is reported. This anomaly terminates when the received report on the *fec-p* anomaly is terminated.
- Far-end block error (*febe-p*): This anomaly occurs when a *crc-p* anomaly detected at the far end is reported. This anomaly terminates when the received report on the *crc-p* anomaly is terminated.

11.3.1.3 Near-end defects

- Loss of signal (*los*): A reference power is established by averaging the VDSL2 receive power over a 0.1 s period and over a subset of subcarriers used for Showtime, and a threshold shall be set 6 dB below this level. An *los* occurs when the level of the VDSL2 receive power averaged over a 0.1 s period and over the same subset of subcarriers is lower than the threshold, and terminates when this level, measured in the same way, is at or above the threshold. The subset of subcarriers is implementation dependent.
- Severely errored frame (*sef*): This defect occurs when the content of two consecutively received sync symbols does not correlate with the expected content over a subset of the subcarriers. An *sef* terminates when the content of two consecutively received sync symbols correlates with the expected content over the same subset of the subcarriers. The correlation method, the selected subset of subcarriers, and the threshold for declaring these defect conditions are vendor discretionary.
- Loss of margin (*lom*): This defect occurs when the signal-to-noise ratio margin (SNRM, see clause 11.4.1.1.6) observed by the near-end receiver is below the minimum signal-to-noise ratio margin (MINSNRM, see clause 12.3.5.2.1.1) and an increase of SNRM is no longer possible within the far-end aggregate transmit power and transmit PSD level constraints. This defect terminates when the SNRM is above the MINSNRM. The SNRM measurement update rate shall be at least once every 5 seconds.

11.3.1.4 Far-end defects

- Far-end loss of signal (*los-fe*): This defect occurs when an *los* detected at the far end is reported in at least 4 of 6 consecutively received far-end *los* indicator reports. An *los-fe* terminates when fewer than two far-end *los* indicators are reported out of 6 consecutively received reports.
- Remote defect indication (*rdi*): This defect occurs when an *sef* detected at the far end is reported. An *rdi* terminates when the received report on *sef* is terminated, i.e., when the value of the corresponding IB is reset to ONE.
- Far-end loss of margin (*lom-fe*): This defect occurs when the signal-to-noise ratio margin (SNRM, see clause 11.4.1.1.6) at the far-end receiver, retrieved by the near-end transmitter is below the minimum signal-to-noise ratio margin (MINSNRM, see clause 12.3.5.2.1.1) and an increase of SNRM is no longer possible within the near-end aggregate transmit power and transmit PSD level constraints. This defect terminates when the SNRM is above the MINSNRM.

11.3.2 Path-related primitives

Path-related primitives are defined separately for each path, terminated by the corresponding TPS-TC. The primitives for each TPS-TC (ATM, PTM, STM, etc.) shall be represented by relevant OAM indicators specified for this protocol.

11.3.2.1 Anomalies and defects for ATM transport

The specified set of anomalies and defects for the ATM transport shall be supported by the ATM-TC. In the case of multiple bearer channels, the corresponding ATM-TCs shall be represented by independent sets of indicators. The anomalies and defect indicators shall comply with clause L.2.

11.3.2.2 Anomalies and defects for STM transport

The specified set of anomalies and defects for the STM transport shall be supported by the STM-TC. In the case of multiple bearer channels, the corresponding STM-TCs shall be represented by independent sets of indicators. The anomalies and defect indicators shall comply with clause L.1.

11.3.2.3 Anomalies and defects for PTM transport

The anomalies and defects for the PTM transport shall be supported by the PTM-TC. In the case of multiple bearer channels, the corresponding PTM-TCs shall be represented by independent sets of indicators. The anomalies and defect indicators shall comply with clause L.3.

11.3.3 Power-related primitives

11.3.3.1 Near-end primitives

Loss of power (*lpr*): This primitive occurs when the VTU power supply (mains) voltage drops below the manufacturer-determined level required for proper VTU operation. An *lpr* terminates when the power level exceeds the manufacturer-determined minimum power level.

11.3.3.2 Far-end primitives

Far-end loss of power (*flpr*): This primitive detected at the far end is reported by the *flpr* indicator, which shall be coded 1 to indicate that no *lpr* is being reported and shall be coded 0 for the next 3 *lpr* indicator transmissions to indicate that an *flpr* (i.e., "dying gasp") is being reported. An *flpr* occurs when 2 or more out of 3 consecutively received *lpr* indicators are set to ZERO. An *flpr* terminates when, for a period of 0.5 seconds, the received *lpr* indicator bit is set to ONE and no near-end *los* is present.

11.3.4 INM primitives

INM-related primitives represent anomalies related to PMD and PMS-TC sublayers.

11.3.4.1 INM INPEQ histogram primitives

If INM_INPEQ_FORMAT=0, then the INM INPEQ histogram shall be configured with a linear scale as follows:

- INMAINPEQ₁..INMAINPEQ₁₆: every INMAINPEQ_{*i*} is a primitive detected at the near end only. This anomaly occurs when the equivalent INP (as defined in clause 11.4.2.2.1) is exactly *i* DMT symbols.
- INMAINPEQ₁₇ is a primitive detected at the near end only. This anomaly occurs when the equivalent INP (as defined in clause 11.4.2.2.1) is strictly more than 16 DMT symbols.

If INM_INPEQ_FORMAT=1 then the INM INPEQ histogram shall be configured with a logarithmic scale as follows ($\lfloor x \rfloor$ denotes rounding to the lower integer):

- INMAINPEQ₁..INMAINPEQ₁₆: every INMAINPEQ_{*i*} is a primitive detected at the near end only. This anomaly occurs when the equivalent INP (as defined in clause 11.4.2.2.1) falls in the range from $\lfloor 1.33^{i+1} \rfloor$ to $\lfloor 1.33^{i+2} \rfloor - 1$ DMT symbols, both boundaries inclusive.
- INMAINPEQ₁₇ is a primitive detected at the near end only. This anomaly occurs when the equivalent INP (as defined in clause 11.4.2.2.1) is at least $\lfloor 1.33^{17+1} \rfloor = 169$ DMT symbols.

NOTE – The logarithmic scale gives rise to the following possible INMAINPEQ histogram ranges (in DMT symbols). It gives a finer granularity for the higher probability short duration impulses, whilst still capturing some information about the longer duration events.

1	2	3	4	5	6	7	8	9	10	11	12	13	14	15	16	17
1 – 1	2 – 2	3 – 3	4 – 4	5 – 6	7 – 8	9 – 12	13 – 16	17 – 22	23 – 29	30 – 39	40 – 53	54 – 71	72 – 94	95 – 126	127 – 168	≥ 169

11.3.4.2 INM total measurement primitive

- INMAME: is a primitive detected at the near end only. This indication occurs every time a data symbol is processed by the impulse noise sensor.

11.3.4.3 INM inter-arrival time histogram primitives

- INMAIAT₀ is a primitive detected at the near end only. This anomaly occurs when the reported value of IAT falls in the range from 2 to INMIATO-1, both boundaries inclusive.
- INMAIAT₁..INMAIAT₆: every INMAIAT_i is a primitive detected at the near end only. This anomaly occurs when the reported value of IAT falls in the range from (INMIATO + (i – 1) × (2^{INMIATS})) to (INMIATO – 1) + i × (2^{INMIATS}), both boundaries inclusive.
- INMAIAT₇ is a primitive detected at the near end only. This anomaly occurs when the reported value of IAT falls in the range from INMIATO + 6 × (2^{INMIATS}) to infinity.

11.4 OAM parameters

The system may support and use the relevant OAM parameters for the VTU-O and VTU-R, as specified in clauses 7.2 and 7.3 of [ITU-T G.997.1]. Specifically, these are:

- Line-related and Path-related performance parameters;
- Line-related and Path-related configuration parameters; and
- Inventory parameters.

Test parameters shall be computed and formatted as specified in clause 11.4.1 to be reported in the format specified in [ITU-T G.997.1].

11.4.1 Test parameters

The test parameters are measured by the PMD transmit or receive function and shall be reported on request to the near-end VME. Test parameters can be used to identify possible issues with the physical loop and to check for adequate physical media performance margin at acceptance and after repair verification, or at any other time following the initialization of the VDSL2 system.

The following test parameters shall be passed on request from the receive PMD function to the near-end VME:

- Channel characteristics function $H(f)$ per subcarrier (CCF-ps);
- Quiet line noise PSD $QLN(f)$ per subcarrier (QLN-ps);
- Signal-to-noise Ratio $SNR(f)$ per subcarrier (SNR-ps);
- Loop attenuation per band (LATN-pb);
- Signal attenuation per band (SATN-pb);
- Signal-to-noise ratio margin per band (SNRM-pb);
- Signal-to-noise ratio margin for the ROC (SNRM-ROC);
- Attainable net data rate (ATTNDR);
- Far-end actual aggregate transmit power (ACTATP);
- Far-end actual impulse noise protection (INP_act); and

- Far end actual impulse noise protection of the ROC (INP_act-ROC).

The following test parameter shall be passed on request from the transmit PMD function to the near-end VME:

- Near-end actual aggregate transmit power (ACTATP).

The purposes of making the above information available are:

- $H(f)$ can be used to analyse the physical copper loop condition;
- $QLN(f)$ can be used to analyse the crosstalk;
- $SNR(f)$ can be used to analyse time-dependent changes in crosstalk levels and loop attenuation (such as due to moisture and temperature variations); and
- The combination of $H(f)$, $QLN(f)$ and $SNR(f)$ can be used to help determine why the data rate is not equal to the maximum data rate for a given loop.

The detailed diagnostic information $H(f)$ and $QLN(f)$ would be most useful during showtime. However, requesting this would place an undue computational burden on the VTUs. Thus, the combination of complete information on the channel ($H(f)$ and $QLN(f)$) during initialization combined with initialization and showtime $SNR(f)$ is provided as a reasonable compromise. This combination of data will allow greater analysis of the loop conditions than traditional methods and will reduce interruptions to both VDSL2 and the underlying service that traditional diagnostic methods require.

The quiet line noise (QLN), signal-to-noise ratio (SNR), and channel characteristics in format (Hlin, Hlog) shall be represented by subcarrier groups. The number of subcarriers, G , in one subcarrier group shall be equal to:

$$G = \text{pow2}(\Theta/512)$$

where the function $\text{pow2}(x)$ takes the nearest power of 2 greater than or equal to x and Θ is the highest subcarrier index of the transmitter SUPPORTEDCARRIERS set if the parameter is measured during the channel discovery phase; or the last subcarrier index of the transmitter MEDLEY set in other cases.

Specific carrier sets to be used during showtime and loop diagnostic mode are summarized in Table 11-42 (N/A indicates that a parameter is not applicable).

Table 11-42 – Value of G for various phases of operation

Test parameter	Normal operation	Loop diagnostic mode	
	Showtime	Channel discovery	Channel analysis and exchange
QLN	SUPPORTEDCARRIERS	SUPPORTEDCARRIERS	N/A
HLOG	SUPPORTEDCARRIERS	SUPPORTEDCARRIERS	N/A
HLIN	N/A	N/A	MEDLEY
SNR	MEDLEY	N/A	MEDLEY

Valid values of G are 1, 2, 4 and 8.

11.4.1.1 Definition of test parameters

11.4.1.1.1 Channel characteristics function per subcarrier group (CCF-ps)

The channel characteristics function $H(f)$ is a quantity that is related to the values of the (complex) source and load impedances. A simplified definition is used in which the source and load impedances are the same and equal to a real value R_N . The channel characteristics function $H(f)$ is associated with

a two-port network, normalized to a chosen reference resistance R_N . $H(f)$ shall be defined as a complex value, equal to the U_2/U_1 voltage ratio (see Figures 11-3 and 11-4).

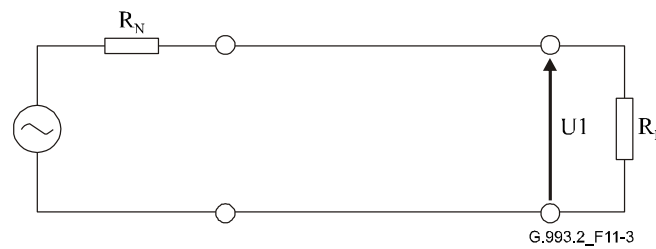

Figure 11-3 – Voltage across the load

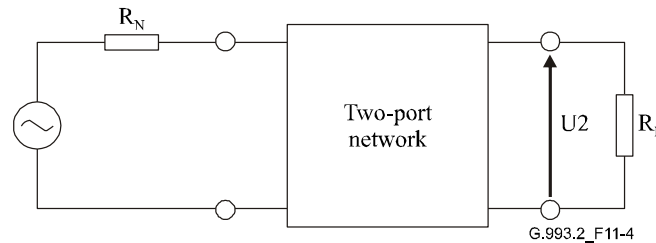

Figure 11-4 – Voltage across the load with a two-port network inserted

The measurement of a channel characteristics function is the result of the cascade of three functions:

- the transmitter filter characteristics function;
- the channel characteristics function; and
- the receiver filter characteristics function.

NOTE – The channel characteristics function corresponds to the $H_{\text{channel}}(f)$ function used in the definition of the far-end crosstalk (see clause 7.4.1 of [ITU-T G.996.1]).

The objective is to provide means by which the channel characteristics can be accurately identified. Therefore, it is necessary for the receive PMD function to report an estimate of the channel characteristics. This task may prove to be a difficult one given the fact that the receive PMD function only observes the cascade of all three elements of the channel. The passband part of the reported $H(f)$, which is most essential to debug possible issues with the physical loop, is not expected to significantly depend upon the receiver filter characteristics (not including receiver AGC). The receive PMD function shall therefore invert the gain (AGC) it has applied to the received signal and do a best effort attempt to remove the impact of the near-end receiver filter characteristics. The result is then a best estimate of how the receiver views the passband channel characteristics plus the transmitter filter characteristics. Because the in-band portion of the spectrum is also expected not to significantly depend upon the transmitter filter characteristics, this result is considered a sufficient estimate of the channel characteristics for desired loop conditioning applications.

Two formats for the channel characteristics are defined:

- $H_{\text{lin}}(f)$: a format providing complex values on a linear scale; and
- $H_{\text{log}}(f)$: a format providing magnitude values on a base 10 logarithmic scale.

For $H_{\text{log}}(f)$, the receive PMD function shall also use the value of the PSD at the U interface of the transmit PMD function (as conveyed in messages during initialization) to remove the impact of the far-end transmit filter characteristics.

For $H_{\text{lin}}(f)$, if the channel characteristics are reported over the VTU-O OAM interface (see Figure 5-3), the VTU-O shall do a best effort attempt to remove the impact of the near-end transmit filter characteristics from the channel characteristics measured at the VTU-R. If the channel

characteristics are reported over the VTU-R OAM interface, the VTU-R shall do a best effort attempt to remove the impact of the near-end transmit filter characteristics from the channel characteristics measured at the VTU-O.

Hlin(f) shall be sent to the far-end VME during the loop diagnostic mode and shall be sent on request to the near-end VME during the loop diagnostic mode.

Hlog(f) shall be measured by the receive PMD function during the loop diagnostic mode and initialization. The measurement shall not be updated during showtime. Hlog(f) shall be sent to the far-end VME during the loop diagnostic mode and shall be sent on request to the near-end VME at any time. The near-end VME shall send Hlog(f) to the far-end VME on request during showtime.

In loop diagnostic mode, both Hlin(f) and Hlog(f) shall be measured, because the corrections that can be done, relative to the receiver and/or transmitter filter characteristics with Hlin(f) and Hlog(f), may differ.

Hlin(f) and Hlog(f) shall be measured over a 1 second time period in loop diagnostic mode. In initialization, the VTU should do its best to optimize the accuracy of the Hlog(f) measurement; however, it shall measure at least 256 symbols, and shall indicate the measurement period (in symbols, represented as a 16-bit unsigned value) to the far-end VME (see clause 11.2.3.11).

The channel characteristics function Hlin($k \times G \times \Delta f$) shall be the value of the channel characteristics on the subcarrier $i = k \times G$. It shall be represented in linear format by a scale factor and a normalized complex number $a(k) + j \times b(k)$, $k = 0$ to 511. The scale factor shall be coded as a 16-bit unsigned integer. Both $a(k)$ and $b(k)$ shall be coded as 16-bit twos complement signed integers. The value of Hlin($k \times G \times \Delta f$) shall be defined as:

$$\text{Hlin}(k \times G \times \Delta f) = (\text{scale}/2^{15}) \times (a(k) + j \times b(k))/2^{15}$$

In order to maximize precision, the scale factor, scale , shall be chosen such that $\max(|a(k)|, |b(k)|)$ over all k is equal to $2^{15} - 1$.

This data format supports an Hlin(f) granularity of 2^{-15} and an Hlin(f) dynamic range of approximately 96 dB (+6 dB to -90 dB). The portion of the scale factor range above 0 dB is necessary because, due to manufacturing variations in signal path gains and filter responses, short loops may appear to have a gain rather than a loss.

An Hlin($k \times G \times \Delta f$) value indicated as $a(k) = b(k) = -2^{15}$ is a special value. It indicates that:

- no measurement could be done for this subcarrier because it is out of the transmitter MEDLEY set or its $g_i = 0$; or
- the attenuation is out of the range to be represented.

The channel characteristics function Hlog($k \times G \times \Delta f$) shall be the magnitude of the channel characteristics at subcarrier $k \times G$. It shall be represented in base 10 logarithmic format by an integer number $m(k)$, where $k = 0$ to 511. The $m(k)$ shall be coded as 10-bit unsigned integers. The value of Hlog($k \times G \times \Delta f$) shall be defined as:

$$\text{Hlog}(k \times G \times \Delta f) = 6 - (m(k)/10)$$

This data format supports an Hlog(f) granularity of 0.1 dB and an Hlog(f) dynamic range of approximately 102 dB (+6 dB to -96 dB).

An Hlog($k \times G \times \Delta f$) value indicated as $m(k) = 2^{10} - 1$ is a special value. It indicates:

- that no measurement could be done for this subcarrier because it is out of the transmitter SUPPORTEDCARRIERS set; or
- that the attenuation is out of the range to be represented.

11.4.1.1.2 Quiet line noise PSD per subcarrier group (QLN-ps)

The quiet line noise PSD $QLN(f)$ for a particular subcarrier is the rms level of the noise present on the loop when no VDSL2 signals are present on the loop. The received virtual noise PSD as defined in SNRM_MODE=2, SNRM_MODE=3, SNRM_MODE=4, and SNRM_MODE=5 shall not be taken into account in $QLN(f)$.

The quiet line noise PSD $QLN(f)$ per subcarrier shall be measured by the receive PMD function during loop diagnostic mode and initialization. The measurement shall not (i.e., cannot) be updated during showtime. The $QLN(f)$ shall be sent to the far-end VME during loop diagnostic mode and shall be sent on request to the near-end VME at any time. The near-end VME shall send the $QLN(f)$ to the far-end VME on request during showtime.

The objective is to provide means by which the quiet line noise PSD can be accurately identified. Therefore, it would be necessary for the receive PMD function to report an estimate of the quiet line noise PSD. This task may prove to be a difficult one given the fact that the receive PMD function observes the noise through the receiver filter. The passband part of the reported QLN-ps, which is most essential to debug possible issues with the physical loop, is not expected to significantly depend upon the receiver filter characteristics (not including receiver AGC). The receive PMD function shall therefore invert the gain (AGC) it has applied to the received signal and do a best effort attempt to remove the impact of the near-end receiver filter characteristics. The result is then a best estimate of how the receiver views the passband quiet line noise PSD. This result is considered a sufficient estimate of the quiet line noise PSD for desired loop conditioning applications.

The receive PMD function shall measure the $QLN(f)$ in a time interval when no VDSL2 signals are present on the loop (i.e., the near-end and far-end transmitters are inactive). The quiet line noise PSD $QLN(i \times \Delta f)$ shall be measured over a 1 second time interval in loop diagnostic mode. In initialization, the VTU should do its best to optimize the accuracy of the $QLN(f)$ measurement, however, it shall measure over at least 256 symbols, and shall indicate the measurement period (in symbols, represented as a 16-bit unsigned value) to the far-end VME (see clause 11.2.3.11).

The quiet line noise PSD $QLN(k \times G \times \Delta f)$ shall be the average of the power values of quiet line noise on the subcarriers $k \times G$ to $((k+1) \times G) - 1$. It shall be represented as an 8-bit unsigned integer $n(k)$, where $k = 0$ to 511. The value of $QLN(k \times G \times \Delta f)$ shall be defined as $QLN(k \times G \times \Delta f) = -23 - (n(k)/2)$ dBm/Hz. This data format supports a $QLN(f)$ granularity of 0.5 dB with a range of values for $QLN(f)$ from -150 to -23 dBm/Hz.

A $QLN(k \times G \times \Delta f)$ value indicated as $n(k) = 255$ is a special value. It indicates that:

- no measurement could be done for this subcarrier group because one of its subcarriers is out of the transmitter SUPPORTEDCARRIERS set; or
- the quiet line noise PSD is out of the range to be represented.

11.4.1.1.3 Signal-to-noise ratio per subcarrier group (SNR-ps)

The signal-to-noise ratio $SNR(f)$ for a particular subcarrier is a real value that shall represent the ratio between the received signal power and the received noise power for that subcarrier. The received virtual noise PSD as defined in SNRM_MODE=2, SNRM_MODE=3, and SNRM_MODE=4 shall not be taken into account in $SNR(f)$.

The signal-to-noise ratio $SNR(f)$ per subcarrier shall be measured by the receive PMD function in loop diagnostic mode and initialization. The measurement may be updated autonomously and shall be updated on request during showtime. The $SNR(f)$ shall be sent to the far-end VME during loop diagnostic mode and shall be sent on request to the near-end VME at any time. The near-end VME shall send the $SNR(f)$ to the far-end VME on request during showtime.

The receive PMD function shall measure the signal-to-noise ratio $SNR(f)$ with the transmit PMD function in a MEDLEY or showtime state. The signal-to-noise ratio $SNR(f)$ shall be measured

over a 1 second time interval in loop diagnostic mode. In initialization and showtime, the VTU should do its best to minimize the SNR(f) measurement time, however it shall measure over at least 256 symbols, and it shall indicate the measurement period (in symbols, represented as a 16-bit unsigned value) to the far-end VME (see clause 11.2.3.11).

The signal-to-noise ratio SNR($k \times G \times \Delta f$) shall be the average of the base 10 logarithmic value of the signal-to-noise ratio on the subcarriers $k \times G$ to $((k+1) \times G) - 1$. It shall be represented as an 8-bit unsigned integer $snr(k)$, where $k = 0$ to 511. The value of SNR($k \times G \times \Delta f$) shall be defined as SNR($k \times G \times \Delta f$) = $-32 + (snr(k)/2)$ dB. This data format supports an SNR($k \times G \times \Delta f$) granularity of 0.5 dB and an SNR($k \times G \times \Delta f$) dynamic range of 127 dB (-32 to 95 dB).

An SNR($k \times G \times \Delta f$) value indicated as $snr(k) = 255$ is a special value. It indicates that:

- no measurement could be done for this subcarrier group because one of its subcarriers is out of the transmitter MEDLEY set or its $g_i = 0$; or
- the signal-to-noise ratio is out of the range to be represented.

11.4.1.1.4 Loop attenuation per band (LATN-pb)

The loop attenuation in the m^{th} downstream band is denoted as LATN_D(m), and the loop attenuation in the m^{th} upstream band is denoted as LATN_U(m). For ease of notation, this clause provides requirements and definitions in terms of the downstream loop attenuation, but the same definitions and requirements also apply to LATN_U(m).

The loop attenuation of the m^{th} downstream band (LATN_D(m)) is the squared magnitude of the channel characteristics function $H(f)$ (as defined in clause 11.4.1.1.1) averaged over all subcarriers of the m^{th} downstream band, converted to dB. LATN_D(m) shall be defined as:

$$\text{LATN_D}(m) = -10 \times \log_{10} \left(\frac{\sum_{i=n1}^{n2} |H(i \times \Delta f)|^2}{N_D(m)} \right)$$

with $N_D(m)$ (the number of subcarriers in the m^{th} downstream band) = $n2 - n1 + 1$ where $n1$ and $n2$ are the indices of the first and the last subcarriers of this band, respectively, and $H(f)$ is represented by $H_{\text{lin}}(f)$ in loop diagnostic mode and by $H_{\text{log}}(f)$ in initialization (with conversion of \log_{10} to linear values for use in the above equation).

If one or more $H(f)$ values could not be measured because they are out of the transmitter SUPPORTEDCARRIERS set (see clause 11.4.1.1.1), then the LATN_D(m) shall be calculated as an average of $H(f)$ values over the number of subcarriers for which valid values of $H(f)$ are available.

The loop attenuation shall be calculated by the receive PMD function during loop diagnostic mode and initialization. The calculation shall not be updated during showtime. The loop attenuation shall be sent to the far-end VME during initialization and loop diagnostic mode and shall be sent on request to the near-end VME at any time. The near-end VME shall send the LATN to the far-end VME on request during showtime.

The loop attenuation per downstream band LATN_D(m) shall be represented as a 10-bit unsigned integer $latn$, with the value of LATN_D(m) defined as LATN_D(m) = $latn/10$ dB. This data format supports a LATN_D(m) granularity of 0.1 dB and an LATN_D(m) dynamic range of 102.2 dB (0 to 102.2 dB).

A LATN_D(m) value indicated as $latn = 1023$ is a special value. It indicates that the loop attenuation is out of the range that can be represented.

11.4.1.1.5 Signal attenuation per band (SATN-pb)

The signal attenuation in the m^{th} downstream band is denoted as $\text{SATN_D}(m)$, and the signal attenuation in the m^{th} upstream band is denoted as $\text{SATN_U}(m)$. For ease of notation, this clause provides requirements and definitions in terms of the downstream signal attenuation, but the same definitions and requirements also apply to $\text{SATN_U}(m)$.

The signal attenuation of the m^{th} downstream band, $\text{SATN_D}(m)$, is defined as the difference in dB between the power received at the near end and that transmitted from the far end in the m^{th} downstream band.

Mathematically, this corresponds to:

$$\text{SATN_D}(m) = \text{TXpower_dBm_D}(m) - \text{RXpower_dBm_D}(m)$$

During initialization and loop diagnostic mode, the received signal power in dBm, $\text{RXpower_dBm_D}(m)$, shall be computed as the received subcarrier power, summed over those subcarriers of this band that are in the MEDLEYds set. During transmission of O-P-MEDLEY and R-P-MEDLEY, the transmit PSD for subcarriers in the MEDLEYds set is at the MREFPSDs level. Therefore, the received signal power shall be fine-tuned with the g_i values for each subcarrier in the MEDLEYds set to estimate the signal power that will be received during showtime.

Mathematically, this corresponds to:

$$\text{RXpower_dBm_D}(m) = 10 \times \log_{10} \left(\sum_{i \in (\text{MEDLEYds} \cap \text{DS}(m))} \left(\text{Received_subcarrier_power_mW}(i) \times g_i^2 \right) \right)$$

During showtime, the received signal power in dBm, $\text{Rxpower_dBm_D}(m)$, shall be computed as the received subcarrier power in showtime, summed over those subcarriers of this band that are in the MEDLEYds set.

Mathematically, this corresponds to:

$$\text{RXpower_dBm_D}(m) = 10 \times \log_{10} \left(\sum_{i \in (\text{MEDLEYds} \cap \text{DS}(m))} \left(\text{Received_subcarrier_power_mW}(i) \right) \right)$$

In both equations, $\text{MEDLEYds} \cap \text{DS}(m)$ denotes all subcarriers of the MEDLEYds set that fall into the m^{th} downstream band, $\text{Received_subcarrier_power_mW}$ is the received power on subcarrier i expressed in milli-Watts, and g_i is the gain (linear scale) for subcarrier i .

The received power for $\text{SATN_U}(m)$ shall be computed in the same way, but using subcarriers from the MEDLEYus set falling into the m^{th} upstream band.

For the SATN value determined during initialization, the received signal power for each subcarrier i in the MEDLEYds set shall be fine-tuned with the g_i value conveyed in the O-PMD (for the upstream direction) and R-PMD (for the downstream direction) messages to estimate the signal power that will be received during showtime. During loop diagnostic mode, the fine tuning shall be restricted to using g_i values 0 (for subcarriers to which no bits can be allocated) and 1 (for subcarriers to which at least one bit can be allocated). For the SATN value determined during Showtime, the received signal subcarrier power shall be taken as measured.

The transmitted signal power in dBm, $\text{TXpower_dBm_D}(m)$, corresponds to the part of the NOMATP (see clause 10.3.4.2.1) falling in this band. It shall be computed as the aggregate transmit power, summed over the subcarriers of this band that are in the MEDLEYds set. During transmission of O-P-MEDLEY, the transmit PSD for subcarriers in the MEDLEYds set is at the MREFPSDs level. Therefore, the transmitted signal power shall be fine-tuned with the g_i values for each subcarrier in the MEDLEYds set to estimate the signal power that will be transmitted during showtime.

Mathematically, this corresponds to:

$$\text{TXpower_dBm_D}(m) = 10 \times \log_{10} \Delta f + 10 \times \log_{10} \left(\sum_{i \in \text{MEDLEYds} \cap \text{DS}(m)} \left(10^{\frac{\text{MREFPSD}[i]}{10}} \times g_i^2 \right) \right)$$

where $\text{MEDLEYds} \cap \text{DS}(m)$ denotes all subcarriers of the MEDLEYds set that fall into the m^{th} downstream band, $\text{MREFPSD}[i]$ is the value of MREFPSDds for subcarrier i in dBm/Hz as conveyed by the O-PRM message, g_i is the gain (linear scale) for subcarrier i , and Δf is the subcarrier spacing in Hz.

The transmit power for $\text{SATN_U}(m)$ shall be computed in the same way, but using subcarriers from the MEDLEYus set falling into the m^{th} upstream band, and the value of $\text{MREFPSD}[i]$ is the value of MREFPSDus for subcarrier i in dBm/Hz as conveyed by the R-PRM message.

For the SATN value determined during initialization, the transmit signal power for each subcarrier i in the MEDLEYds set shall be fine-tuned with the g_i value conveyed in the O-PMD (for the upstream direction) and R-PMD (for the downstream direction) messages to estimate the transmit signal power during showtime. During loop diagnostic mode, the fine tuning shall be restricted to using g_i values 0 (for subcarriers to which no bits can be allocated) and 1 (for subcarriers to which at least one bit can be allocated). For the SATN value determined during showtime, the transmitted signal power shall be fine-tuned with the active g_i values for each subcarrier in the MEDLEY set.

The signal attenuation shall be measured by the receive PMD function during loop diagnostic mode and initialization (i.e., estimate the signal attenuation at the start of showtime). The measurement may be updated autonomously and shall be updated on request during showtime. The signal attenuation shall be sent to the far-end VME during initialization and loop diagnostic mode and shall be sent on request to the near-end VME at any time. The near-end VME shall send the $\text{SATN_D}(m)$ to the far-end VME on request during showtime.

The signal attenuation per downstream band, $\text{SATN_D}(m)$, shall be represented as a 10-bit unsigned integer $satn$, with the value of $\text{SATN_D}(m)$ defined as $\text{SATN_D}(m) = satn/10$ dB. This data format supports an $\text{SATN_D}(m)$ granularity of 0.1 dB and an $\text{SATN_D}(m)$ dynamic range of 102.2 dB (0 to 102.2 dB).

An $\text{SATN_D}(m)$ value indicated as $satn = 1023$ is a special value. It indicates that the signal attenuation is out of range to be represented.

11.4.1.1.6 Signal-to-noise ratio margin

11.4.1.1.6.1 General definition of signal-to-noise ratio margin

The signal-to-noise ratio margin is the maximum increase (scalar gain, in dB) of the reference noise PSD (at all relevant frequencies), such that the BER of each bearer channel does not exceed 10^{-7} (see clause 9.8), without any change of PMD parameters (e.g., bits and gains) and PMS-TC parameters (e.g., L_p , FEC parameters). The BER is referenced to the output of the PMS-TC function (i.e., the α/β interface).

The definition of the reference noise PSD depends on the control parameter SNRM_MODE.

11.4.1.1.6.1.1 SNRM_MODE = 1

SNRM_MODE = 1 is a mandatory capability for both VTUs.

The reference noise PSD equals the received current-condition external noise PSD only, as measured by the near-end transceiver (i.e., equal to the PSD of the noise measured by the near-end transceiver at the constellation decoder or other relevant internal reference point when the only noise source is the external stationary noise applied to the U interface and no internal noise sources are present).

NOTE – Mathematically this can be illustrated by:

$$\text{Received_External_Noise_PSD} = |H_{\text{RXfilter}}(f)|^2 \times \text{External_Noise_PSD_at_U_interface}$$

11.4.1.1.6.1.2 SNRM_MODE = 2

SNRM_MODE = 2 is an optional capability for both VTUs.

The reference noise PSD equals the maximum of the received current-condition external noise PSD (as defined in SNRM_MODE=1) and the received virtual noise PSD, at a common internal reference point.

The received virtual noise PSD shall be determined by the transceiver as defined in the following equation.

$$\text{Received_Virtual_Noise_PSD} = |H(f)|^2 \times \text{TXREFVN}$$

where TXREFVN is the transmitter-referred virtual noise PSD MIB parameter.

$|H(f)|^2$ is calculated as:

$$|H(f)|^2 = \frac{\text{Actual_Received_Signal_PSD}}{\text{Actual_Transmit_Signal_PSD}}$$

where:

- Actual_Transmit_Signal_PSD is the actual transmit signal PSD at the far-end transmitter as calculated by the near-end transceiver.
- Actual_Received_Signal_PSD is the actual received signal PSD at the near-end transceiver as measured by the near-end transceiver (i.e., equal to the PSD measured by the near-end transceiver at the constellation decoder or other relevant internal reference point) during initialization and Showtime.

Mathematically this can be expressed as:

$$\text{Actual_Received_Signal_PSD} = |H_{\text{RXfilter}}(f)|^2 \times \text{Received_Signal_PSD_at_U_interface}$$

NOTE – A measurement of the current-condition external noise PSD could be overly optimistic, as it only represents a snapshot in time, not taking into account the future increase in noise PSD (e.g., due to additional VDSL2 lines being switched on). The SNRM_MODE=2 is defined to prevent the VTU's bit loading algorithm from assigning an overly optimistic number of bits to a subcarrier. This is achieved by defining (via the transmitter-referred virtual noise PSD parameter TXREFVN) an anticipated noise PSD, which may be a function of frequency that can be used for bit loading.

This method can be used to avoid or reduce periods with excessive BER and retrains, in order to assure service quality and stability. It is expected that the configuration, via the MIB, is based on anticipated service penetration and noise environment.

11.4.1.1.6.1.3 SNRM_MODE = 3

SNRM_MODE = 3 is an optional capability for upstream (i.e., VTU-O receiver) only.

The reference noise PSD equals the maximum of the received current-condition external noise PSD (as defined in SNRM_MODE=1) and the received virtual noise PSD, at a common internal reference point.

The received virtual noise PSD shall be determined by the transceiver as defined in the following equation.

$$\text{Received_Virtual_Noise_PSD} = |H_{\text{RXfilter}}(f)|^2 \times \text{RXREFVN}$$

where:

$|H_{\text{RXfilter}}(f)|$ is the magnitude of the transfer function between the U-interface and the common internal reference point, and

RXREFVN is the receiver-referred virtual noise PSD MIB parameter.

NOTE – A measurement of the current-condition external noise PSD could be overly optimistic, as it only represents a snapshot in time, not taking into account the future increase in noise PSD (e.g., due to additional VDSL2 lines being switched on). The SNRM_MODE = 3 is defined to prevent the VTU's bit loading algorithm from assigning an overly optimistic number of bits to a subcarrier. This is achieved by defining (via the receiver-referred virtual noise PSD parameter RXREFVN) an anticipated noise PSD, which may be a function of frequency that can be used for bit loading.

This method can be used to avoid or reduce periods with excessive BER and retrains, in order to assure service quality and stability. It is expected that the configuration, via the MIB, is based on anticipated service penetration and noise environment.

11.4.1.1.6.1.4 SNRM_MODE = 4

SNRM_MODE = 4 is an optional capability for both upstream and downstream.

The reference noise PSD equals the maximum of the received current-condition external noise PSD (as defined in SNRM_MODE=1) and the received virtual noise PSD, at a common internal reference point.

In the downstream direction, the received virtual noise PSD shall be determined by the transceiver as defined in the following equation:

$$\text{Received_Virtual_Noise_PSD} = |H(f)|^2 \times \text{TXREFVNds}$$

where:

$|H(f)|^2$ is calculated as in SNRM_MODE=2, and

TXREFVNds is the transmitter-referred virtual noise PSD control parameter as conveyed in O-SIGNATURE.

In SNRM_MODE= 4, the control parameter TXREFVNds is a combination of the configuration parameter TXREFVNds and the configuration parameter TXREFVNSFds as described in clause 11.4.2.5.

In the upstream direction, the received virtual noise PSD shall be determined by the transceiver as defined in the following equation:

$$\text{Received_Virtual_Noise_PSD} = |H_{\text{RXfilter}}(f)|^2 \times \text{RXREFVNus}$$

where:

$|H_{\text{RXfilter}}(f)|$ is the magnitude of the transfer function between the U-interface and the common internal reference point, and

RXREFVNus is the receiver-referred virtual noise PSD control parameter.

In SNRM_MODE=4, the control parameter RXREFVNus is a combination of the configuration parameter RXREFVNus and the configuration parameter RXREFVNSFus as described in clause 11.4.2.4.

NOTE 1 – A measurement of the current-condition external noise PSD could be overly optimistic, as it only represents a snapshot in time, not taking into account the future increase in noise PSD (e.g., due to additional VDSL2 lines being switched on). SNRM_MODE = 4 is defined to prevent the VTU's bit loading algorithm from assigning an overly optimistic number of bits to a subcarrier. This is achieved by defining (via the virtual noise PSD parameter and the virtual noise scaling factor parameter) an anticipated noise PSD, which may be a function of frequency that can be used for bit loading. This method can be used to avoid or reduce periods with excessive BER and retrains, in order to assure service quality and stability. It is expected that the configuration, via the MIB, is based on anticipated service penetration and noise environment.

NOTE 2 – SNRM_MODE=4 is similar to SNRM_MODE=3 in the upstream direction and SNRM_MODE=2 in the downstream direction. Per line configuration in SNRM_MODE=2, 3 and 4 may be accomplished by configuration of a different value for the configuration parameter Virtual Noise (VNus or VNds, see clauses 7.3.1.7.3 and 7.3.1.7.4 of [ITU-T G.997.1]) on a line by line basis. Per line configuration in SNRM_MODE=4 may also be accomplished by the configuration of a common value for the configuration

parameter Virtual Noise (VNus or VNds) for a group of lines combined with the configuration of a scaling factor (TXREFVNSFds or RXREFVNSFus) on a line by line basis.

11.4.1.1.6.1.5 SNRM_MODE = 5

SNRM_MODE = 5 is an optional capability for both upstream and downstream. A transceiver supporting operation with SNRM_MODE = 5 shall also support SRA.

The SNRM_MODE = 5 can be applied in both directions (i.e., for both VTU-O and VTU-R receivers). If SNRM_MODE = 5 is applied in at least one direction, then an *msg* bit rate of at least 64 kbit/s shall be used in both directions.

The reference noise PSD is equal to the maximum of the received current-condition external noise PSD (as defined in SNRM_MODE=1) and the received showtime adaptive virtual noise (SAVN) PSD, at a common internal reference point.

The received SAVN PSD value shall be determined by the transceiver as defined in the following equation.

$$\text{Received_SAVN_PSD} = |H(f)|^2 \times \text{TXREFSAVN}(f),$$

where TXREFSAVN(*f*) is the transmitter-referred SAVN PSD parameter at frequency *f*, and $|H(f)|^2$ is calculated as defined in clause 11.4.1.1.6.1.2.

The value of TXREFSAVN is set at initialization and may be updated during showtime. At initialization, the downstream SAVN PSD and upstream SAVN PSD are determined by the VTU-O. The initial value of the downstream SAVN PSD (TXREFSAVNds) is communicated to the VTU-R in the TXREFVNds field in the O-SIGNATURE message (see clause 12.3.3.2.1.1). During showtime, the VTU-O may update the value of the downstream SAVN PSD based on noise estimations or actual noise measurements at the VTU-R, e.g., noise changes due to other lines going in and out of the low power mode (see Annex E of [ITU-T G.998.4]). The update of TXREFSAVNds is communicated to the VTU-R via a SAVN-Update eoc command (see clause 11.2.3.16). During showtime, the VTU-O may also update the value of the upstream SAVN PSD based on noise estimations or actual noise measurements at the near-end. The VTU-O may estimate the SNR at the remote end by using the Test Parameter Read command defined in clause 11.2.3.11. Other estimation methods are for further study. Upon an update of the received SAVN PSD, the VTU shall verify whether the update requires a modification of the bit loading. If a modification is required, the VTU shall perform an SRA to adjust the bit loading in accordance with the updated value of the received SAVN PSD.

NOTE 1 – To identify changes in the SNR, the VTU-O ME may request the SNR read right after implementation of an SRA command, or a bit swap command, or after SOS.

The range of TXREFSAVNds, TXREFSAVNus values shall be in the boundaries determined by the CO-MIB (parameters TXREFSAVNds-MIN/MAX, TXREFSAVNus-MIN/MAX defined in Table 11-42.1).

NOTE 2 – To set the initial values of TXREFSAVNds, TXREFSAVNus, the VTU-O may take in account the values TXREFVNds and TXREFVNus (see clause 11.4.2.1) provided by the CO-MIB, respectively.

Table 11-42.1 – CO-MIB configuration parameters related to SAVN

Configuration parameter	Definition
TXREFSAVNds-MIN	TXREFSAVNds-MIN indicates a minimum value, such that TXREFSAVNds is greater than or equal to TXREFSAVNds-MIN for all applicable subcarriers. The valid range is –150 to –23 dBm/Hz in steps of 0.5dB.
TXREFSAVNds-MAX	TXREFSAVNds-MAX indicates a maximum value, such that TXREFSAVNds is less than or equal to TXREFSAVNds-MAX for all applicable subcarriers. The valid range is –150 to –23 dBm/Hz in steps of 0.5dB.
TXREFSAVNus-MIN	TXREFSAVNus-MIN indicates a minimum value, such that TXREFSAVNus is greater than or equal to TXREFSAVNus-MIN for all applicable subcarriers. The valid range is –150 to –23 dBm/Hz in steps of 0.5dB.
TXREFSAVNus-MAX	TXREFSAVNus-MAX indicates a maximum value, such that TXREFSAVNus is less than or equal to TXREFSAVNus-MAX for all applicable subcarriers. The valid range is –150 to –23 dBm/Hz in steps of 0.5dB.

11.4.1.1.6.2 Signal-to-noise ratio margin parameter (SNRM)

The signal-to-noise ratio margin parameter, SNRM, is the signal-to-noise ratio margin (as defined in clause 11.4.1.1.6.1) measured over all subcarriers, except the subcarriers assigned to the ROC, in a transmission direction for which $b_i > 0$. The received virtual noise PSD as defined in clauses 11.4.1.1.6.1.2, 11.4.1.1.6.1.3, 11.4.1.1.6.1.4, and 11.4.1.1.6.1.5 shall be taken into account, respectively, when configured in SNRM_MODE=2, SNRM_MODE=3, SNRM_MODE=4, and SNRM_MODE=5.

The signal-to-noise ratio margin shall be measured by the receive PMD function during initialization. The measurement may be updated autonomously and shall be updated on request during showtime. The SNRM shall be sent to the far-end VTU during initialization and loop diagnostic mode and shall be sent on request to the near-end VME at any time. The near-end VME shall send the SNRM to the far-end VME on request during showtime.

To determine the SNRM, the receive PMD function must be able to first determine the bits and gains table. During loop diagnostic mode, the receive PMD function shall use the special value to indicate that the SNRM value was not measured.

The signal-to-noise ratio margin in the downstream direction shall be represented as a 10-bit twos complement signed integer $snrm$, with the value of SNRMds defined as $SNRMds = snrm/10$ dB. This data format supports an SNRMds granularity of 0.1 dB and an SNRMds dynamic range of 102.2 dB (–51.1 to +51.1 dB).

An SNRMds value indicated as $snrm = -512$ is a special value. It indicates that the signal-to-noise ratio margin is out of the range to be represented. During loop diagnostic mode, the special value shall be used to indicate that the SNRMds value was not measured.

The same definition and representation shall apply to the signal-to-noise ratio margin in the upstream direction, SNRMus.

11.4.1.1.6.3 Signal-to-noise ratio margin per band (SNRM-pb)

The signal-to-noise ratio margin in the m^{th} downstream band is denoted as SNRM_D(m), and the signal-to-noise ratio margin in the m^{th} upstream band is denoted as SNRM_U(m). For ease of notation, this clause provides requirements and definitions in terms of the downstream signal-to-noise ratio margin, but the same definitions and requirements also apply to SNRM_U(m).

The signal-to-noise ratio margin per band parameter SNRM-pb is the signal-to-noise ratio margin (as defined in clause 11.4.1.1.6.1) measured over all subcarriers in a particular band for which $b_i > 0$. The received virtual noise PSD as defined in clauses 11.4.1.1.6.1.2, 11.4.1.1.6.1.3, 11.4.1.1.6.1.4, and 11.4.1.1.6.1.5 shall be taken into account, respectively, when configured in SNRM_MODE=2, SNRM_MODE=3, SNRM_MODE=4, and SNRM_MODE=5.

The signal-to-noise ratio margin per band is the maximum increase (in dB) in the received noise power that can be tolerated in this band, such that the VTU can still meet all target BERs over all bearer channels.

The signal-to-noise ratio margin per band shall be measured by the receive PMD function during initialization. The measurement may be updated autonomously and shall be updated on request during showtime. The signal-to-noise ratio margin per band shall be sent to the far-end VME during initialization and loop diagnostic mode and shall be sent on request to the near-end VME at any time. The near-end VME shall send the SNRM-pb to the far-end VME on request during showtime.

To determine the SNRM-pb, the receive PMD function must be able to first determine the bits and gains table. During loop diagnostic mode, the receive PMD function shall use the special value to indicate that the SNRM-pb value was not measured.

The signal-to-noise ratio margin per downstream band shall be represented as a 10-bit two's complement signed integer *snrm*, with the value of SNRM_D(*m*) defined as $SNRM_D(m) = snrm/10$ dB. This data format supports an SNRM_D(*m*) granularity of 0.1 dB and an SNRM_D(*m*) dynamic range of 102.2 dB (−51.1 to +51.1 dB).

An SNRM_D(*m*) value indicated as $snrm = -512$ is a special value. It indicates that the signal-to-noise ratio margin is out of the range to be represented. During loop diagnostic mode, the special value shall be used to indicate that the SNRM_D(*m*) value was not measured.

11.4.1.1.6.4 Signal-to-noise ratio margin for the ROC (SNRM-ROC)

The SNRM-ROC is the signal-to-noise ratio margin related to transmission of the ROC, as defined in clause 9.1, Figure 9-2. The definition of SNRM-ROC is as in clause 11.4.1.1.6.1 applied to the MPS-TC and BER=10^{−7} for all bits transmitted over latency path #0, Figure 9-2. The SNRM-ROC shall be measured over all subcarriers assigned to the ROC for which $b_i > 0$ in a transmission direction. The received virtual noise PSD as defined in clause 11.4.1.1.6.1.2 shall be taken into account when configured in SNRM_MODE=2.

The SNRM-ROC shall be measured by the receive PMD function during initialization. The measurement may be updated autonomously and shall be updated on request during Showtime. The SNRM-ROC shall be sent to the far-end VTU during initialization and shall be sent on request to the near-end VME at any time. The near-end VME shall send the SNRM-ROC to the far-end VME on request during Showtime. The receive PMD function shall use a special value to indicate that the SNRM value was not measured (e.g., in Loop Diagnostic mode or if the ROC is not enabled or not supported).

The SNRM-ROC shall use the same representation as defined for SNRM in clause 11.4.1.1.6.2.

11.4.1.1.7 Attainable net data rate (ATTNDR)

The attainable net data rate is the maximum net data rate that the receive PMS-TC and PMD functions are designed to support, assuming certain conditions. Assumed conditions depend on the control parameter *attndr_method* (single method applicable to both upstream and downstream directions): either the basic method (*attndr_method*=0, see clause 11.4.1.1.7.1) or the improved methods (*attndr_method*=1 or 2, see clause 11.4.1.1.7.2). The *attndr_method* value is sent to the VTU-R during initialization (see clause 12.3.5.2.2.1). The actual *attndr_method* value is reported through the CO-MIB parameter ATTNDR_ACTMETHOD (see clause 7.5.1.41.1 of [ITU-T G.997.1]).

The improved Attainable Net Data Rate method shall be used if the CO-MIB parameter *ATTNDR_METHOD* (see clause 7.3.1.15.1 of [ITU-T G.997.1]) is set to a value of 1 or 2, and the mode is supported by the VTU-O and by the VTU-R. In this case the value of the control parameter *attndr_method* shall have the same value as the CO-MIB configuration parameter *ATTNDR_METHOD* (i.e., *attndr_method*=*ATTNDR_METHOD*). Otherwise, the basic Attainable Net Data Rate method shall be used. In this case the value of the control parameter *attndr_method* is zero (i.e., *attndr_method*=0).

To accurately determine the attainable net data rate (ATTNDR), the receive PMD function must be able to first determine the bits and gains table. Therefore, during loop diagnostic mode, the ATTNDR value for upstream and downstream shall be calculated as:

$$\text{ATTNDR} = \sum_{i=0}^{MSI} \min \left\{ \text{round} \left[\log_2 \left(1 + 10^{(\text{SNR}(i \times \Delta f) - \text{SNRGAP} - \text{TARSNRM})/10} \right) \right], 15 \right\} \times 4 \text{ kbit/s}$$

with $\text{SNR}(i \times \Delta f)$ in dB as defined in clause 11.4.1.1.3, but accounting for the received virtual noise PSD when configured in *SNRM_MODE*=2, *SNRM_MODE*=3, *SNRM_MODE*=4, or *SNRM_MODE*=5 and *SNRGAP*= 9.75 dB (Note 1).

NOTE 1 – The *SNRGAP* value is defined for a 10^{-7} bit error ratio on 4-QAM (no coding gain, *INP_min0* = 0).

NOTE 2 – The value calculated for ATTNDR during loop diagnostic mode may not be identical to the value calculated during Showtime with the same PMD parameters and under the same loop conditions.

The attainable net data rate shall be calculated by the receive PMS-TC and PMD functions during loop diagnostic mode and initialization. The measurement may be updated autonomously and shall be updated on request during showtime. The attainable net data rate shall be sent to the far-end VME during loop diagnostic mode and shall be sent on request to the near-end VME at any time. The near-end VME shall send the ATTNDR to the far-end VME on request during showtime.

The attainable net data rate shall be represented as a 32-bit unsigned integer *attndr*, with the value of ATTNDR defined as $\text{ATTNDR} = \text{attndr}$ bit/second. This data format supports an ATTNDR granularity of 1 bit/s.

No special value is defined.

11.4.1.1.7.1 The basic attainable net data rate method

Support of the basic attainable net data rate method is mandatory.

The attainable net data rate is the maximum net data rate that the receive PMS-TC and PMD functions are designed to support, assuming the following conditions:

- single bearer channel and single latency operation;
- target SNR margin equal to the configured *TARSNRMds*/*TARSNRMus* downstream and upstream, respectively;
- latency not to exceed the highest latency configured for the bearer channel ($\text{delay_act0} \leq \text{delay_max0}$);
- accounting for all coding gains available (e.g., trellis coding, FEC) within the latency bound;
- accounting for the channel characteristics at the instant of measurement; and
- accounting for the received virtual noise PSD when configured in *SNRM_MODE*=2, *SNRM_MODE*=3, *SNRM_MODE*=4, or *SNRM_MODE*=5.

NOTE – The conditions of the basic method in this version of the Recommendation are unchanged compared to the conditions for ATTNDR calculation in previous versions of this Recommendation. This set of conditions did not specify a number of conditions to calculate ATTNDR, which lead to vendor discretionary behaviour in the reported ATTNDR values. It is recommended that implementations that are upgraded from a previous version of this Recommendation to this version of this Recommendation, in case of *attndr_method*=0 use the

same vendor discretionary behaviour as used when operating according to the previous version of this Recommendation.

11.4.1.1.7.2 The improved attainable net data rate method

Support of the improved attainable net data rate method is optional.

The attainable net data rate is the maximum net data rate that the receive PMS-TC and PMD functions are designed to support, assuming the conditions of the basic attainable net data rate method (see clause 11.4.1.1.7.1) and the following conditions:

- if operating in single bearer channel mode, the ATTNDR calculation shall use single bearer channel mode. If operating in dual bearer channel mode, the ATTNDR calculation shall use single bearer channel mode (see clause 8.1.3.1);
- if operating in single latency mode, the ATTNDR calculation shall use single latency mode. If operating in dual latency mode, the ATTNDR calculation shall use single latency mode. If operating in single latency with ROC mode, the ATTNDR calculation shall use single latency with ROC mode (see clause 9.1);
- if the control parameter *attndr_method* is set to a value of 1, the VTU-O and VTU-R shall use the impulse noise protection limit *INP_min₀* with value as indicated in O-TPS (see clause 12.3.5.2.1.2). If O-TPS configures for dual bearer channel mode, then the highest *INP_min_n* over the bearer channels shall be used;
- if the control parameter *attndr_method* is set to a value of 2, the VTU-O and VTU-R shall use an impulse noise protection limit *INP_min₀* = 0;
- the VTU-O and VTU-R shall use the maximum delay *delay_max₀* with value as indicated in O-TPS (see clause 12.3.5.2.1.2). If O-TPS configures for dual bearer channel mode, then the lowest *delay_max_n* over the bearer channels shall be used;
- use of Erasure decoding or not is identical to usage on the bearer channels;
- taking into account the framing limitations;
- if ATM bonding is set in the ITU-T G.994.1 bonding code tree, the VTU-O and VTU-R shall use the minimum delay *delay_min₀* as defined in clause L.2.7. If O-TPS configures for dual bearer channel mode, then the lowest *delay_min_n* over the bearer channels shall be used;
- Taking into account the value of the ATTNDR_MDOSPLIT parameter;
- Net data rate is not limited by the configured maximum net data rate;
- Channel Initialization Policy CIP = 0;
- Transmit PSD is equal to MREFPSD for all subcarriers for which $g_i \neq 0$.

NOTE 1 – The ATTNDR value may be lower due to possible transmit power reductions, as a consequence of configured MAXMARGIN setting, configured MAXNDR setting and vendor discretionary transmit power reductions (e.g., subcarriers with $g_i = 0$, due to AFE dynamic range, ...).

NOTE 2 – The basic method does not specify a number of conditions to calculate ATTNDR, which leads to vendor discretionary behaviour in the reported ATTNDR values. The improved method defines additional conditions to reduce variation of reported ATTNDR values over implementations.

When the ATTNDR value is reported during Showtime, the following parameters used in the calculation of the ATTNDR shall also be reported over the eoc with the ATTNDR value (see Table 11-30), and also be reported in the CO-MIB with the ATTNDR value (see clauses 7.5.1.19 and 7.5.1.20 of [ITU-T G.997.1]):

- *ATTNDR_INP_act₀* (see clauses 7.5.1.41.2 and 7.5.41.3 of [ITU-T G.997.1]);
- *ATTNDR_delay_act₀* (see clauses 7.5.1.41.6 and 7.5.41.7 of [ITU-T G.997.1]).

The parameter *ATTNDR_INP_act₀* is the far-end actual impulse noise protection used in the calculation of the ATTNDR. The actual impulse noise protection *ATTNDR_INP_act₀* shall be

represented as an 8-bit unsigned integer $attndr_inp_act_0$, with the value of $ATTNDR_INP_act_0$ defined as $ATTNDR_INP_act_0 = attndr_inp_act_0 / 10$ DMT symbols. This data format supports an $ATTNDR_INP_act_0$ granularity of 0.1 DMT symbol. The range is from 0 DMT symbols (represented as 0) to 25.4 DMT symbols (represented as 254). The value 255 is a special value indicating an $ATTNDR_INP_act_0$ higher than 25.4 DMT symbols.

The parameter $ATTNDR_delay_act_0$ is the far-end actual delay used in the calculation of the ATTNDR. The actual delay $ATTNDR_delay_act_0$ shall be represented as an 8-bit unsigned integer $attndr_delay_act_0$, with the value of $ATTNDR_delay_act_0$ defined as $ATTNDR_delay_act_0 = attndr_delay_act_0 / 10$ ms. This data format supports an $ATTNDR_delay_act_0$ granularity of 0.1 ms. The range is from 0 ms (represented as 0) to 25.4 ms (represented as 254). The value 255 is a special value indicating an $ATTNDR_DELAY_act_0$ higher than 25.4 ms.

11.4.1.1.8 Actual aggregate transmit power (ACTATP)

The actual aggregate transmit power (ACTATP) is the total amount of output power delivered by the transmit PMD function to the U reference point at tip-and-ring (in dB), at the instant of measurement. The transmit PMD function shall take the NOMATP (see clause 10.3.4.2.1) as a best estimate of the near-end actual aggregate transmit power.

The receive PMD function shall take NOMATP (see clause 10.3.4.2.1) as a best estimate of the far-end actual aggregate transmit power.

The near-end and far-end actual aggregate transmit power shall be calculated by the VTU during initialization using the assigned values of g_i . The measurement may be updated autonomously and shall be updated on request during showtime. The near-end and far-end actual aggregate transmit power shall be sent on request to the near-end VME. The near-end VME shall send the near-end and far-end ACTATP to the far-end VME on request during showtime.

To determine the near-end actual aggregate transmit power (ACTATP), the transmit PMD function must first receive the bits and gains table from the receive PMD function. Therefore, during loop diagnostic mode, the g_i values shall be determined as value 1 (for all subcarriers in the MEDLEY set).

The actual aggregate transmit power shall be represented as a 10-bit twos complement signed integer $actatp$, with the value of ACTATP defined as $ACTATP = actatp/10$ dBm. This data format supports an ACTATP granularity of 0.1 dB, with an ACTATP dynamic range of 62 dB (–31 to + 31 dBm).

An ACTATP value indicated as $actatp = -512$ is a special value. It indicates that the actual aggregate transmit power is out of the range to be represented.

11.4.1.1.9 Actual Impulse Noise Protection (INP_act)

The actual impulse noise protection INP_act_n of bearer channel #n is defined in clause 9.6.

The actual impulse noise protection INP_act_n of bearer channel #n shall be represented as an 8-bit unsigned integer inp_act_n , with the value of INP_act_n defined as $INP_act_n = inp_act_n / 10$ DMT symbols. This data format supports an INP_act_n granularity of 0.1 DMT symbol. The range is from 0 DMT symbols (represented as 0) to 25.4 DMT symbols (represented as 254). The value 255 is a special value indicating an INP_act_n higher than 25.4 DMT symbols.

11.4.1.1.10 Actual impulse noise protection of the ROC (INP_act-ROC)

The INP_act -ROC is the actual impulse noise protection of the ROC, as defined in clause 9.1, Figure 9-2. It shall be computed as $INP_act-ROC = INP_no_erasure_0$ (see clause 9.6).

The parameter INP_act -ROC is expressed in DMT symbols.

The parameter ACTINP-ROC in the CO-MIB is expressed in multiples of T_{4k} . The value is coded in fractions of T_{4k} periods with a granularity of 0.1 of a period. The range is from 0 to 25.4. At the

Q-reference point, a special value indicates an ACTINP-ROC higher than 25.4. The T_{4k} is defined in clause 10.4.4.

The VTU-O shall calculate ACTINP-ROC as follows:

For 4.3125 kHz subcarrier spacing:

$$\text{ACTINP-ROC} = \text{MIN}(\lfloor 10 \times \text{INP_act-ROC} \rfloor / 10; 25.5).$$

For 8.625 kHz subcarrier spacing:

$$\text{ACTINP-ROC} = \text{MIN}(\lfloor 5 \times \text{INP_act-ROC} \rfloor / 10; 25.5).$$

11.4.1.2 Accuracy of test parameters

This clause defines accuracy requirements for test parameters defined in clause 11.4.1.1. The accuracy requirement is expressed as a tolerance relative to a reference value. Both the reference value and the allowed tolerance are defined in this clause.

The accuracy requirements of test parameters are optional. A VTU may comply with the accuracy requirements for all or a subset of the test parameters. For subcarriers and subcarrier groups to which accuracy requirements do not apply (see clauses 11.4.1.2.1 to 11.4.1.2.8), the VTU shall report test parameters as defined in clause 11.4.1.1 but the accuracy of these reported values may not comply with the accuracy requirements further defined in this clause.

NOTE – The measurement of test parameter reference values involves the use of test equipment. The accuracy requirements defined in this clause do not take into account test equipment tolerance. Test equipment tolerance is out of the scope of this Recommendation and is to be added to the tolerances defined in this clause.

11.4.1.2.1 Accuracy of channel characteristics function per subcarrier group (CCF-ps)

11.4.1.2.1.1 Accuracy of $\text{Hlog}(k \times G \times \Delta f)$

The downstream $\text{HLOG}(f)$ reference value for frequency $k \times G \times \Delta f$ shall be defined as:

$$\text{HLOG_reference_ds}(k \times G \times \Delta f) = \text{MREFPSDds}(k \times G \times \Delta f) - \text{PSD_UR2}(k \times G \times \Delta f),$$

where $\text{PSD_UR2}(k \times G \times \Delta f)$ is the PSD measured at the U-R2 reference point with the VTU-O connected to the loop and frozen in the O-P-MEDLEY stage of initialization with the SOC in the O-IDLE state, and with the VTU-R replaced by an $R_N=100$ Ohm resistance terminating the loop.

The upstream $\text{HLOG}(f)$ reference value for frequency $k \times G \times \Delta f$ shall be defined as:

$$\text{HLOG_reference_us}(k \times G \times \Delta f) = \text{MREFPSDus}(k \times G \times \Delta f) - \text{PSD_UO2}(k \times G \times \Delta f),$$

where $\text{PSD_UO2}(k \times G \times \Delta f)$ is the PSD measured at the U-O2 reference point with the VTU-R connected to the loop and frozen in the R-P-MEDLEY stage of initialization with the SOC in the R-IDLE state, and with the VTU-O replaced by an $R_N=100$ Ohm resistance terminating the loop.

NOTE 1 – The feature to freeze a VTU in the MEDLEY stage of initialization exists solely to allow a test bed to be constructed for the purpose of measuring the $\text{Hlog}(f)$ reference values. It applies only to specific transceivers serving as the 'transmit transceiver' of the test environment, and is not a requirement for compliance with this Recommendation.

The receiving VTU shall measure the $\text{Hlog}(f)$ values under the same loop, noise, temperature, and configuration settings that are used for measuring the $\text{Hlog}(f)$ reference values.

The accuracy requirements for the $\text{Hlog}(k \times G \times \Delta f)$ shall only apply to those subcarrier groups with an SNR (as defined in clause 11.4.1.1.3) ≥ 12 dB, where the SNR is the SNR value measured during initialization, after the Channel Discovery phase.

The accuracy requirements for the downstream $\text{Hlog}(k \times G \times \Delta f)$ (ITU-T G.997.1 parameter HLOGpsds):

- shall not apply to subcarrier groups that contain subcarriers from the downstream BLACKOUT set;

- shall not apply to subcarrier groups that contain subcarriers in the RFI bands or that contain any of the 15 subcarriers adjacent to each side of the RFI bands, and
- shall only apply to subcarrier groups for which all subcarriers within the group fall within the following frequency ranges (defined as a part of the passband):
 - For Annex A, Masks D-32, D-48, and D-64 of Table A.8:
 - Subcarrier 92 to Subcarrier 869 and Subcarrier 1206 to Subcarrier 1971 for profiles 8a, 8b, 8c, 8d, 12a, 12b and 17a.
 - For Annex A Mask D-128 of Table A.8:
 - Subcarrier 184 to Subcarrier 869 and Subcarrier 1206 to Subcarrier 1971 for profiles 8a, 8b, 8c, 8d, 12a, 12b and 17a.
 - For Annex B Band Plan 998 of Table B.1:
 - Subcarrier 92 to Subcarrier 869 and Subcarrier 1206 to Subcarrier 1971 for profiles 8a, 8b, 8c, 8d, 12a, 12b and 17a.
 - For Annex B Band Plan 997 of Table B.1:
 - Subcarrier 92 to Subcarrier 695 and Subcarrier 1183 to Subcarrier 1634 for profiles 8a, 8b, 8c, 8d, 12a, 12b and 17a.
 - For Annex C, Masks in Tables C.1, C.2, C.5 and C.6:
 - Subcarrier 92 to Subcarrier 869 and Subcarrier 1206 to Subcarrier 1971 for profiles 8a, 8b, 8c, 8d, 12a, 12b and 17a.
 - For Annex C, Masks in Table C.9:
 - Subcarrier 214 to Subcarrier 869 and Subcarrier 1206 to Subcarrier 1971 for profiles 8a, 8b, 8c, 8d, 12a, 12b and 17a.

Accuracy requirements for Annex B band plans 998ADE and HPE are for further study.

Accuracy requirements for Profile 30a are for further study.

Accuracy requirements outside these specified ranges are for further study.

The accuracy requirements for the upstream $H\log(k \times G \times \Delta f)$ (ITU-T G.997.1 parameter HLOGpsus):

- shall not apply to subcarrier groups that contain subcarriers from the upstream BLACKOUT set;
- shall not apply to subcarrier groups that contain subcarriers in the RFI bands or that contain any of the 15 subcarriers adjacent to each side of the RFI bands; and
- shall only apply to subcarrier groups for which all subcarriers within the group fall within the following frequency ranges (defined as a part of the passband):
 - For Annex A, Annex B Band Plan 998 of Table B.1 and Annex C:
 - Subcarrier 870 to Subcarrier 1205 for profiles 8a, 8b, 8c and 8d.
 - Subcarrier 870 to Subcarrier 1205 and Subcarrier 1972 to Subcarrier 2782 for profiles 12a, 12b and 17a.
 - For Annex B Band Plan 997 of Table B.1:
 - Subcarrier 696 to Subcarrier 1182 for profile 8c.
 - Subcarrier 696 to Subcarrier 1182 and Subcarrier 1635 to Subcarrier 2047 for profiles 8a, 8b and 8d.
 - Subcarrier 696 to Subcarrier 1182 and Subcarrier 1635 to Subcarrier 2782 for profiles 12a, 12b and 17a.

Accuracy requirements for Annex B band plans 998ADE and HPE are for further study.

Accuracy requirements for Profile 30a are for further study.

Accuracy requirements for the US0 band (for all relevant profiles) are for further study.

Accuracy requirements outside these frequency ranges are for further study.

NOTE 2 – Having such specified ranges for accuracy requirements avoids variations due to the tolerances and effects of the filtering at the low ends of the passband and of the effects of folding at the high end of the passband.

The accuracy requirements for downstream and upstream $H\log(k \times G \times \Delta f)$ shall only apply for those subcarrier groups where the loop impedance (Z_{loop}) falls within the following ranges for all the subcarriers in the group:

- Impedance magnitude is between 100 Ohm and 120 Ohm;
- Impedance imaginary component is between -20 Ohm and 0 Ohm.

Z_{loop} is defined as the impedance seen by the receiving transceiver under test, looking into the loop, including the transmitting transceiver connected to the loop at the far end.

Accuracy requirements for downstream and upstream $H\log(k \times G \times \Delta f)$, for frequencies where Z_{loop} falls outside this range, are for further study.

NOTE 3 – Appendix II provides an informative discussion of the effects on the accuracy of $H\log(f)$ measurements caused by impedance mismatch between a nominal 100 Ohm termination of the loop and possible termination impedances (Z_{VTU}) actually provided by a VTU.

For each subcarrier group where the accuracy requirement for downstream $H\log(k \times G \times \Delta f)$ applies (based on its subcarrier indexes and downstream $SNR(k \times G \times \Delta f)$ value only, and not considering restrictions related to its Z_{loop} values), and where $HLOGps_reference_ds(k \times G \times \Delta f)$ is above -90 dB, a downstream $H\log(k \times G \times \Delta f)$ value different from the special value defined in clause 11.4.1.1.1 shall be reported.

For each subcarrier group where the accuracy requirement for downstream $H\log(k \times G \times \Delta f)$ applies, and where $HLOGps_reference_ds(k \times G \times \Delta f)$ is above -90 dB, the absolute error between the downstream $H\log(k \times G \times \Delta f)$ and $HLOGps_reference_ds(k \times G \times \Delta f)$ shall be ≤ 3 dB.

The accuracy requirements for downstream $H\log(k \times G \times \Delta f)$ shall apply to its measurement either during Initialization or in Loop Diagnostic mode.

For each subcarrier group where the accuracy requirement for upstream $H\log(k \times G \times \Delta f)$ applies (based on its subcarrier indexes and upstream $SNR(k \times G \times \Delta f)$ value only, and not considering restrictions related to its Z_{loop} values), and where $HLOGps_reference_us(k \times G \times \Delta f)$ is above -90 dB, an upstream $H\log(k \times G \times \Delta f)$ value different from the special value defined in clause 11.4.1.1.1 shall be reported.

For each subcarrier group where the accuracy requirement for upstream $H\log(k \times G \times \Delta f)$ applies, and where $HLOGps_reference_us(k \times G \times \Delta f)$ is above -90 dB, the absolute error between the upstream $H\log(k \times G \times \Delta f)$ and the $HLOGps_reference_us(k \times G \times \Delta f)$ shall be ≤ 3 dB.

The accuracy requirements for upstream $H\log(k \times G \times \Delta f)$ shall apply to its measurement either during Initialization or in Loop Diagnostic mode.

11.4.1.2.1.2 Accuracy of $Hlin(k \times G \times \Delta f)$

The accuracy requirements for the magnitude of $Hlin(k \times G \times \Delta f)$ are the same as those for $H\log(k \times G \times \Delta f)$ in clause 11.4.1.2.1.1.

There is no accuracy requirement for the phase of $Hlin(k \times G \times \Delta f)$.

11.4.1.2.2 Accuracy of quiet line noise PSD per subcarrier group (QLN-ps)

The downstream QLN(f) reference value for subcarrier group k including subcarriers $i = k \times G$ to $((k + 1) \times G) - 1$ shall be defined as:

$$\text{QLNps_reference_ds}(k \times G \times \Delta f) = \frac{1}{G} \sum_{i=kG}^{(k+1)G-1} \text{PSDps_UR2}(i \times \Delta f),$$

where $\text{PSDps_UR2}(i \times \Delta f)$ is the PSD (in logarithmic scale) at frequency $i \times \Delta f$ measured at the U-R2 reference point in the downstream bands, after initialization of the line up to an O-P-QUIET stage, in which stage the VTU-O is frozen and the VTU-R subsequently replaced by an $R_N=100$ Ohm resistance.

The upstream QLN(f) reference value for subcarrier group k including subcarriers $i = k \times G$ to $((k + 1) \times G) - 1$ shall be defined as:

$$\text{QLNps_reference_us}(k \times G \times \Delta f) = \frac{1}{G} \sum_{i=kG}^{(k+1)G-1} \text{PSDps_UO2}(i \times \Delta f),$$

where $\text{PSDps_UO2}(i \times \Delta f)$ is the PSD (in logarithmic scale) at frequency $i \times \Delta f$ measured at the U-O2 reference point in the upstream bands, after initialization of the line up to an R-P-QUIET stage, in which stage the VTU-R is frozen and the VTU-O subsequently replaced by an $R_N=100$ Ohm resistance.

NOTE 1 – The feature to freeze a VTU in a QUIET stage exists solely to allow a test bed to be constructed for the purpose of measuring the QLN(f) reference value. It applies only to specific transceivers serving as the 'transmit transceiver' of the test environment, and is not a requirement for compliance with this Recommendation.

The receiving VTU shall measure the QLN(f) values under the same loop, noise, temperature, and configuration settings as are used for measuring the QLN(f) reference values.

The accuracy requirements for the downstream QLN($k \times G \times \Delta f$) (ITU-T G.997.1 parameter QLNpsds) shall apply to the subcarrier groups in the same frequency bands and with the same loop impedance (Z_{loop}) restrictions as where the downstream Hlog($k \times G \times \Delta f$) accuracy requirements apply (see clause 11.4.1.1.2).

The accuracy requirements for the upstream QLN($k \times G \times \Delta f$) (ITU-T G.997.1 parameter QLNpsus) shall apply to the subcarrier groups in the same frequency bands and with the same loop impedance (Z_{loop}) restrictions as where the upstream Hlog($k \times G \times \Delta f$) accuracy requirements apply (see clause 11.4.1.1.2).

Accuracy requirements outside these frequency ranges are for further study.

NOTE 2 – Having such specified ranges for accuracy requirements avoids variations due to the tolerances and effects of the filtering at the low ends of the passband and of the effects of folding at the high end of the passband.

For each subcarrier group where the accuracy requirement for downstream QLN($k \times G \times \Delta f$) applies (based on its subcarrier indexes only, and not considering restrictions related to its Z_{loop} values), and where $\text{QLNps_reference_ds}(k \times G \times \Delta f)$ is above -130 dBm/Hz, a downstream QLN($k \times G \times \Delta f$) value different from the special value defined in clause 11.4.1.1.2 shall be reported.

For each subcarrier group where the accuracy requirement for downstream QLN($k \times G \times \Delta f$) applies, and where $\text{QLNps_reference_ds}(k \times G \times \Delta f)$ is above -130 dBm/Hz, the absolute error between the downstream QLN($k \times G \times \Delta f$) and the $\text{QLNps_reference_ds}(k \times G \times \Delta f)$ shall be ≤ 3.0 dB. To account for sinusoidal noise sources internal to the VTU-R, this requirement does not apply to up to 5 clusters of N consecutive subcarrier groups per 2.2 MHz bandwidth, which can be selected at the VTU-R vendor's discretion, with $N = 1 + \text{ceil}(W/G)$ and $W = 12$.

For each subcarrier group where the accuracy requirement for downstream $QLN(k \times G \times \Delta f)$ applies, and where $QLNps_reference_ds(k \times G \times \Delta f)$ is above -130 dBm/Hz, the sample variance of downstream $QLN(k \times G \times \Delta f)$ measurements (within a 10 minute measurement window, and under the same loop, noise, temperature, and configuration settings) shall be ≤ 0.5 dB. To account for sinusoidal noise sources internal to the VTU-R, this requirement does not apply to up to 5 clusters of N consecutive subcarrier groups per 2.2 MHz bandwidth, which can be selected at the VTU-R vendor's discretion, with $N = 1 + \text{ceil}(W/G)$ and $W = 12$.

The accuracy requirements for downstream $QLN(k \times G \times \Delta f)$ shall apply to its measurement either during Initialization or in Loop Diagnostic mode.

For each subcarrier group where the accuracy requirement for upstream $QLN(k \times G \times \Delta f)$ applies (based on its subcarrier indexes only, and not considering restrictions related to its Z_{loop} values), and where $QLNps_reference_us(k \times G \times \Delta f)$ is above -120 dBm/Hz, an upstream $QLN(k \times G \times \Delta f)$ value different from the special value defined in clause 11.4.1.1.2 shall be reported.

For each subcarrier group where the accuracy requirement for upstream $QLN(k \times G \times \Delta f)$ applies, and where $QLNps_reference_us(k \times G \times \Delta f)$ is above -120 dBm/Hz, the absolute error between the upstream $QLN(k \times G \times \Delta f)$ and the $QLNps_reference_us(k \times G \times \Delta f)$ shall be ≤ 3.0 dB. To account for sinusoidal noise sources internal to the VTU-O, this requirement does not apply to up to 10 clusters of N consecutive subcarrier groups per 2.2 MHz bandwidth, which can be selected at the VTU-O vendor's discretion, with $N = 1 + \text{ceil}(W/G)$ and $W = 12$.

For each subcarrier group where the accuracy requirement for upstream $QLN(k \times G \times \Delta f)$ applies, and where $QLNps_reference_us(k \times G \times \Delta f)$ is above -120 dBm/Hz, the statistical sample variance of upstream $QLN(k \times G \times \Delta f)$ measurements (within a 10 minute measurement window, and under the same loop, noise, temperature, and configuration settings) shall be ≤ 0.5 dB. To account for sinusoidal noise sources internal to the VTU-O, this requirement does not apply to up to 10 clusters of N consecutive subcarrier groups per 2.2 MHz bandwidth, which can be selected at the VTU-O vendor's discretion, with $N = 1 + \text{ceil}(W/G)$ and $W = 12$.

The accuracy requirements for upstream $QLN(k \times G \times \Delta f)$ shall apply to its measurement either during Initialization or in Loop Diagnostic mode.

11.4.1.2.3 Accuracy of signal-to-noise ratio per subcarrier group (SNR-ps)

Noise PSD changes over time shall be reflected in the reported $SNR(k \times G \times \Delta f)$. This clause defines accuracy requirements for the change in $SNR(k \times G \times \Delta f)$ over a time interval $[T1, T2]$, relative to a reference value. The downstream and upstream reference values for subcarrier group k including subcarriers $i = k \times G$ to $((k + 1) \times G) - 1$ are defined as:

$$\Delta SNRps_reference_ds(k \times G \times \Delta f) = \text{Noise_PSDps_UR2_T1}(k \times G \times \Delta f) - \text{Noise_PSDps_UR2_T2}(k \times G \times \Delta f),$$

$$\Delta SNRps_reference_us(k \times G \times \Delta f) = \text{Noise_PSDps_UO2_T1}(k \times G \times \Delta f) - \text{Noise_PSDps_UO2_T2}(k \times G \times \Delta f),$$

where:

- Noise_PSDps_UR2_T1 is the stationary noise PSD (in dBm/Hz) present on the line at the U-R2 reference point at time instant T1, and for at least one minute before T1;
- Noise_PSDps_UR2_T2 is the stationary noise PSD (in dBm/Hz) present on the line at the U-R2 reference point at time instant T2, and for at least one minute before T2;
- Noise_PSDps_UO2_T1 is the stationary noise PSD (in dBm/Hz) present on the line at the U-O2 reference point at time instant T1, and for at least one minute before T1;
- Noise_PSDps_UO2_T2 is the stationary noise PSD (in dBm/Hz) present on the line at the U-O2 reference point at time instant T2, and for at least one minute before T2.

These four Noise_PSDps's shall be measured by the same method as is used to measure the QLNps_reference (see clause 11.4.1.1.2) and before the SNR measurements. Before the actual measurements of SNR, the two noise PSDs (for time T1 and T2) shall be measured while the transmitting VTU is frozen in a QUIET state. Then the transmitting VTU is allowed to enter SHOWTIME and the SNR measurements are made under the same two Noise_PSDps's. The SNR measurements shall be made under the same loop and temperature conditions as the Noise_PSDps measurements.

The accuracy requirements for the downstream $\text{SNR}(k \times G \times \Delta f)$ (ITU-T G.997.1 parameter SNRpsds) shall apply to those subcarrier groups in the downstream passband where all of the following conditions hold:

- Subcarriers in the subcarrier group are at least 50 kHz away from the lower and higher passband edge,
- $\text{bi_T1}(i) > 0$ and $\text{bi_T2}(i) > 0$ for at least one subcarrier i in the subcarrier group (i between $k \times G$ and $(k+1) \times G - 1$ for subcarrier group k),
- $\text{Noise_PSDps_UR2_T1}(k \times G \times \Delta f)$ and $\text{Noise_PSDps_UR2_T2}(k \times G \times \Delta f)$ are larger than -110 dBm/Hz;
- $(\text{SNRps_T1}(k \times G \times \Delta f) - \frac{1}{G} \sum_{i=kG}^{(k+1)G-1} \text{gi_T1}(i))$ and $(\text{SNRps_T2}(k \times G \times \Delta f) - \frac{1}{G} \sum_{i=kG}^{(k+1)G-1} \text{gi_T2}(i))$ are both smaller than 40 dB,

where:

- $\text{gi_T1}(i)$ and $\text{gi_T2}(i)$ are the downstream fine gains (in dB) at time instants T1 and T2;
- $\text{bi_T1}(i)$ and $\text{bi_T2}(i)$ are the downstream bit loading at time instants T1 and T2;
- $\text{SNRps_T1}(k \times G \times \Delta f)$ and $\text{SNRps_T2}(k \times G \times \Delta f)$ are the downstream SNRs (in dB), measured during showtime, at time instants T1 and T2.

The accuracy requirements for the upstream $\text{SNR}(k \times G \times \Delta f)$ (ITU-T G.997.1 parameter SNRpsus) shall apply to those subcarrier groups in the upstream passband where all of the following conditions hold:

- Subcarriers in the subcarrier group are at least 50kHz away from the lower and higher passband edge;
- $\text{bi_T1}(i) > 0$ and $\text{bi_T2}(i) > 0$, for at least one subcarrier i in the subcarrier group (i between $k \times G$ and $(k+1) \times G - 1$ for subcarrier group k);
- $\text{Noise_PSDps_UO2_T1}(k \times G \times \Delta f)$ and $\text{Noise_PSDps_UO2_T2}(k \times G \times \Delta f)$ are larger than -120 dBm/Hz;
- $(\text{SNRps_T1}(k \times G \times \Delta f) - \frac{1}{G} \sum_{i=kG}^{(k+1)G-1} \text{gi_T1}(i))$ and $(\text{SNRps_T2}(k \times G \times \Delta f) - \frac{1}{G} \sum_{i=kG}^{(k+1)G-1} \text{gi_T2}(i))$ are both smaller than 40 dB,

where:

- $\text{gi_T1}(i)$ and $\text{gi_T2}(i)$ are the upstream fine gains (in dB) at time instants T1 and T2;
- $\text{bi_T1}(i)$ and $\text{bi_T2}(i)$ are the upstream bit loading at time instants T1 and T2;
- $\text{SNRps_T1}(k \times G \times \Delta f)$ and $\text{SNRps_T2}(k \times G \times \Delta f)$ are the upstream SNRs (in dB), measured during showtime, at time instants T1 and T2.

If the line does not re-initialize over a time period T1 to T2, the following requirements shall be met for downstream subcarrier groups where the $\text{SNR}(k \times G \times \Delta f)$ accuracy requirement applies:

$$|(\text{SNRps_T2}(k \times G \times \Delta f) - \frac{1}{G} \sum_{i=kG}^{(k+1)G-1} \text{gi_T2}(i)) - (\text{SNRps_T1}(k \times G \times \Delta f) - \frac{1}{G} \sum_{i=kG}^{(k+1)G-1} \text{gi_T1}(i)) - \Delta \text{SNRps_reference_ds}(k \times G \times \Delta f)| \leq 0.8 \text{ dB.}$$

Accuracy requirements for downstream subcarrier groups where $(\text{SNRps_T1} - \text{gi_T1})$ or $(\text{SNRps_T2} - \text{gi_T2})$ is greater than 40 dB, are for further study.

For each downstream subcarrier group where the $\text{SNR}(k \times G \times \Delta f)$ accuracy requirement applies, the sample variance of $\text{SNR}(k \times G \times \Delta f)$ measurements (expressed in dB and all samples taken within a 10 minute time interval, without line re-initialization in this time interval, and under the same loop, noise, temperature, and configuration settings) shall be equal to or smaller than 0.5, calculated as follows:

$$\text{SNRps_variance} \leq 0.5$$

where

$$\text{SNRps_variance} = \frac{1}{N} \left(\sum_{i=1}^N (\text{SNRps}(i) - \text{SNRps_avg})^2 \right)$$

$$\text{SNRps_avg} = \frac{1}{N} \left(\sum_{i=1}^N \text{SNRps}(i) \right)$$

If the line does not re-initialize over a time period T1 to T2, the following requirements shall be met for upstream subcarrier groups where the $\text{SNR}(k \times G \times \Delta f)$ accuracy requirement applies:

$$|(\text{SNRps_T2}(k \times G \times \Delta f) - \frac{1}{G} \sum_{i=kG}^{(k+1)G-1} \text{gi_T2}(i)) - (\text{SNRps_T1}(k \times G \times \Delta f) - \frac{1}{G} \sum_{i=kG}^{(k+1)G-1} \text{gi_T1}(i)) - \Delta \text{SNRps_reference_us}(k \times G \times \Delta f)| \leq 0.8 \text{ dB.}$$

Accuracy requirements for upstream subcarrier groups where $(\text{SNRps_T1} - \text{gi_T1})$ or $(\text{SNRps_T2} - \text{gi_T2})$ is greater than 40 dB, are for further study.

For each upstream subcarrier group where the $\text{SNR}(k \times G \times \Delta f)$ accuracy requirement applies, the sample variance of $\text{SNR}(k \times G \times \Delta f)$ measurements (expressed in dB and all samples taken within a 10 minute interval, without line re-initialization in this time interval, and under the same loop, noise, temperature, and configuration settings) shall be equal to or smaller than 0.5, calculated as follows:

$$\text{SNRps_variance} \leq 0.5$$

where

$$\text{SNRps_variance} = \frac{1}{N} \left(\sum_{i=1}^N (\text{SNRps}(i) - \text{SNRps_avg})^2 \right)$$

$$\text{SNRps_avg} = \frac{1}{N} \left(\sum_{i=1}^N \text{SNRps}(i) \right)$$

NOTE – In verification tests, noise changes should be applied gradually over time, and not simultaneously at the U-O2 and U-R2 reference point, as not to force a re-initialization of the line.

11.4.1.2.4 Accuracy of loop attenuation per band (LATN-pb)

The downstream LATN reference value shall be defined as follows:

$$\text{LATN_reference_ds}(m) = -10 \times \log_{10} \left(\frac{\sum_{k=n1}^{n2} |\text{H_reference_ds}(k \times \Delta f)|^2}{N_D(m)} \right)$$

In the equation above, $N_D(m)$ (the number of subcarriers in the m th downstream band) = $n2 - n1 + 1$ where $n1$ and $n2$ are the indices of the first and the last subcarriers of this band, respectively, and $\text{H_reference_ds}(k \times \Delta f)$ is defined as:

$$|\text{H_reference_ds}(k \times \Delta f)|^2 = 10^{\text{HLOG_reference_ds}(k \times \Delta f)/10} = 10^{(\text{MREFPSD}_{\text{ds}}(k \times \Delta f) - \text{PSD_UR2}(k \times \Delta f))/10},$$

where $\text{PSD_UR2}(k \times \Delta f)$ is the PSD measured at the U-R2 reference point with the VTU-O connected to the loop and frozen in the O-P-MEDLEY stage of initialization with the SOC in the O-IDLE state, and with the VTU-R replaced by an $R_N=100$ Ohm resistance terminating the loop.

If one or more $\text{H_reference_ds}(f)$ values could not be measured because they are out of the transmitter SUPPORTEDCARRIERS set (see clause 11.4.1.1.1), then the $\text{LATN_D}(m)$ shall be calculated as an average of $\text{H}(f)$ values over the number of subcarriers for which valid values of $\text{H}(f)$ are available. Also,

The upstream LATN reference value shall be defined as follows:

$$\text{LATN_reference_us}(m) = -10 \times \log_{10} \left(\frac{\sum_{k=n1}^{n2} |\text{H_reference_us}(k \times \Delta f)|^2}{N_U(m)} \right)$$

with $N_U(m)$ (the number of subcarriers in the m th upstream band) = $n2 - n1 + 1$ where $n1$ and $n2$ are the indices of the first and the last subcarriers of this band, respectively. The value of $\text{H_reference_ds}(k \times \Delta f)$ is defined as:

$$|\text{H_reference_us}(k \times \Delta f)|^2 = 10^{\text{HLOG_reference_us}(k \times \Delta f)/10} = 10^{(\text{MREFPSD}_{\text{us}}(k \times \Delta f) - \text{PSD_UO2}(k \times \Delta f))/10},$$

where $\text{PSD_UO2}(k \times \Delta f)$ is the PSD measured at the U-O2 reference point with the VTU-R connected to the loop and frozen in the R-P-MEDLEY stage of initialization with the SOC in the R-IDLE state, and with the VTU-O replaced by an $R_N=100$ Ohm resistance terminating the loop.

If one or more $\text{H_reference_us}(f)$ values could not be measured because they are out of the transmitter SUPPORTEDCARRIERS set (see clause 11.4.1.1.1), then the $\text{LATN_U}(m)$ shall be calculated as an average of $\text{H}(f)$ values over the number of subcarriers for which valid values of $\text{H}(f)$ are available.

NOTE – The feature to freeze a VTU in the MEDLEY stage of initialization exists solely to allow a test bed to be constructed for the purpose of measuring the $\text{H}(f)$ reference values. It applies only to specific transceivers serving as the 'transmit transceiver' of the test environment, and is not a requirement for compliance with this Recommendation.

The receiving VTU shall measure the LATN values under the same loop, noise, temperature, and configuration settings that are used for measuring the LATN reference values.

For all downstream bands, m , that are active during loop diagnostics or initialization, the absolute error between $\text{LATN_D}(m)$ and $\text{LATN_reference_ds}(m)$ shall be equal to or smaller than 3 dB.

The accuracy requirements for downstream $\text{LATN_D}(m)$ shall apply to its measurement either during Initialization or in Loop Diagnostic mode.

For all upstream bands, m , that are active during loop diagnostics or initialization, the absolute error between $LATN_U(m)$ and $LATN_reference_us(m)$ shall be equal to or smaller than 3 dB.

The accuracy requirements for upstream $LATN_U(m)$ shall apply to its measurement either during Initialization or in Loop Diagnostic mode.

11.4.1.2.5 Accuracy of signal attenuation (SATN)

The downstream SATN reference value shall be defined as follows:

$$SATN_reference_ds(m) = TXpower_dBm_reference_ds(m) - RXpower_dBm_reference_ds(m)$$

The $TXpower_dBm_reference_ds(m)$ is defined as:

$$TXpower_dBm_reference_ds(m) = 10 \times \log_{10} \Delta f + 10 \times \log_{10} \left(\sum_{i \in MEDLEYds \cap DS(m)} \left(10^{\frac{MREFPSD[i]}{10}} \times g_i^2 \right) \right),$$

where $MEDLEYds \cap DS(m)$ denotes all subcarriers of the $MEDLEYds$ set that fall into the m th downstream band, $MREFPSD[i]$ is the value of $MREFPSDds$ for subcarrier i in dBm/Hz, g_i is as defined in clause 11.4.1.1.5, and Δf is the subcarrier spacing in Hz.

The $RXpower_dBm_reference_ds(m)$ is defined as:

$$RXpower_dBm_reference_ds(m) = 10 \times \log_{10} \left(\sum_{i \in MEDLEYds \cap DS(m)} \left(10^{\frac{PSD_UR2(i \times \Delta f)}{10}} \times g_i^2 \right) \right),$$

where $PSD_UR2(i \times \Delta f)$ is the PSD measured at the U-R2 reference point with the VTU-O connected to the loop and frozen in the O-P-MEDLEY stage of initialization with the SOC in the O-IDLE state, and with the VTU-R replaced by an $R_N=100$ Ohm resistance terminating the loop.

The upstream SATN reference value shall be defined as follows:

$$SATN_reference_us(m) = TXpower_dBm_reference_us(m) - RXpower_dBm_reference_us(m)$$

The $TXpower_dBm_reference_us(m)$ is defined as:

$$TXpower_dBm_reference_us(m) = 10 \times \log_{10} \Delta f + 10 \times \log_{10} \left(\sum_{i \in MEDLEYus \cap US(m)} \left(10^{\frac{MREFPSD[i]}{10}} \times g_i^2 \right) \right),$$

where $MEDLEYus \cap US(m)$ denotes all subcarriers of the $MEDLEYus$ set that fall into the m th upstream band, $MREFPSD[i]$ is the value of $MREFPSDus$ for subcarrier i in dBm/Hz, g_i is as defined in clause 11.4.1.1.5, and Δf is the subcarrier spacing in Hz.

The $RXpower_dBm_reference_us(m)$ is defined as:

$$RXpower_dBm_reference_us(m) = 10 \times \log_{10} \left(\sum_{i \in MEDLEYus \cap US(m)} \left(10^{\frac{PSD_UO2(i \times \Delta f)}{10}} \times g_i^2 \right) \right),$$

where $PSD_UO2(i \times \Delta f)$ is the PSD measured at the U-O2 reference point with the VTU-R connected to the loop and frozen in the R-P-MEDLEY stage of initialization with the SOC in the R-IDLE state, and with the VTU-O replaced by an $R_N=100$ Ohm resistance terminating the loop.

NOTE – The feature to freeze a VTU in the MEDLEY stage of initialization exists solely to allow a test bed to be constructed for the purpose of measuring the $H(f)$ reference values. It applies only to specific transceivers serving as the 'transmit transceiver' of the test environment, and is not a requirement for compliance with this Recommendation.

The receiving VTU shall measure the SATN values under the same loop, noise, temperature and configuration settings that are used for measuring the SATN reference values.

For all downstream bands, m , that are active during loop diagnostics or initialization, the absolute error between $SATN_D(m)$ and $SATN_reference_ds(m)$ shall be equal to or smaller than 3 dB.

The accuracy requirements for downstream $SATN_D(m)$ shall apply to its measurement after Initialization during showtime.

For all upstream bands, m , that are active during loop diagnostics or initialization, the absolute error between $SATN_U(m)$ and $SATN_reference_us(m)$ shall be equal to or smaller than 3 dB.

The accuracy requirements for upstream $SATN_U(m)$ shall apply to its measurement after Initialization during showtime.

11.4.1.2.6 Accuracy of signal-to-noise ratio margin (SNRM)

For further study.

11.4.1.2.7 Accuracy of attainable net data rate (ATTNDR)

For further study.

11.4.1.2.8 Accuracy of actual aggregate transmit power (ACTATP)

The VTU-O near-end ACTATP reference value shall be defined as follows:

$$ACTATP_reference_UO2 = \text{sum_over_all_frequencies} [PSDps_UO2(i)],$$

where $PSDps_UO2(i)$ is the downstream PSD measured at the U-O2 reference point, after initialization of the line up to the SHOWTIME state, in which state the VTU-O is frozen and the VTU-O subsequently connected to an $R_N=100$ Ohms.

The VTU-R near-end ACTATP reference value shall be defined as follows:

$$ACTATP_reference_UR2 = \text{sum_over_all_frequencies} [PSDps_UR2(i)],$$

where $PSDps_UR2(i)$ is the upstream PSD measured at the U-R2 reference point, after initialization of the line up to the SHOWTIME state, in which state the VTU-R is frozen and the VTU-R subsequently connected to an $R_N=100$ Ohms.

NOTE 1 – The ACTATP should be measured first. Subsequently, the VTU should be frozen in SHOWTIME and the $PSDps_Ux$ should then be measured without re-initialization.

NOTE 2 – The measurement of the $PSDps_Ux$ involves freezing in SHOWTIME of the transceiver under test. Specification of special test modes for the transceiver under test is outside the scope of this Recommendation.

The absolute error between the VTU-O near-end $ACTATP_ds$ and the $ACTATP_reference_UO2$ shall be equal to or smaller than 1.0 dB.

The sample variance of the VTU-O near-end $ACTATP_ds$ measurements (all samples taken over a 10 minutes time interval, without line re-initialization and bit/gain-swaps in this time interval, and under the same loop, noise, temperature, and configuration settings) shall be equal to or smaller than 0.5 dB.

NOTE 3 – The $ACTATP_ds$ samples are to be taken after sufficient time is allowed after initialization for bit and gain swaps to stabilize.

The absolute error between the VTU-R near-end $ACTATP_us$ and the $ACTATP_reference_UR2$ shall be equal to or smaller than 1.0 dB.

The sample variance of the VTU-R near-end $ACTATP_us$ measurements (all samples taken over a 10 minute time interval, without line re-initialization and bit/gain-swaps in this time interval, and under the same loop, noise, temperature, and configuration settings) shall be equal to or smaller than 0.5 dB.

NOTE 4 – The $ACTATP_us$ samples are to be taken after sufficient time is allowed after initialization for bit and gain swaps to stabilize.

11.4.2 Configuration parameters

11.4.2.1 Transmitter-referred virtual noise PSD

This clause describes the transmitter-referred virtual noise PSD parameter TXREFVN, used only in the optional SNR margin mode SNRM_MODE = 2, SNRM_MODE = 4, and SNRM_MODE=5.

11.4.2.1.1 Definition of parameter TXREFVN

Configuration parameter TXREFVN defines the transmitter-referred virtual noise PSD to be used in determining the SNR margin.

For SNRM_MODE = 2 and SNRM_MODE = 4, the CO-MIB shall provide a TXREFVN parameter set for each utilized band.

NOTE – For SNRM_MODE=5, the TXREFVN parameter provided by the CO-MIB may be taken into account by the VTU-O to determine the initial value of TXREFSAVN (see clause 11.4.1.1.6.1.5).

The transmitter-referred virtual noise PSD in the CO-MIB shall be specified by a set of breakpoints.

Each breakpoint shall consist of a subcarrier index t_n and a noise PSD (expressed in dBm/Hz). The TXREFVN parameter for each utilized band shall be a set of breakpoints that are represented by $[(t_1, PSD_1), (t_2, PSD_2), \dots, (t_n, PSD_n), (t_{NBP}, PSD_{NBP})]$, where t_1 and t_{NBP} are, respectively, the lower and higher band edge frequencies of the band.

The subcarrier indices t_i shall be coded in the CO-MIB as unsigned integers in the range from $t_1 = \text{roundup}(f_x/Df)$ to $t_{NBP} = \text{rounddown}(f_{x+1}/Df)$, where f_x, f_{x+1} are the low and the high band separating frequencies determined by the applied band plan and specified in clause 7.1, and $Df = 4.3125$ kHz. The breakpoints shall be defined so that $t_n < t_{n+1}$ for $n = 1$ to $N - 1$; the frequency f_n corresponding to the index t_n can be found as: $f_n = t_n \times Df$. The value of Df is independent of the subcarrier spacing Δf used for DMT modulation. When the VTU operates with 8.625 kHz subcarrier spacing, all odd values of t_i shall be converted by the VTU, by rounding down to the next lower even value, and values t_1 and t_{NBP} shall be rounded (up and down, respectively) to even values.

The values for the transmitter-referred virtual noise PSD shall be coded as 8-bit unsigned integers representing virtual noise PSDs from -40 dBm/Hz (coded as 0) to -140 dBm/Hz (coded as 200), in steps of 0.5 dBm/Hz. Values from 201 to 255, inclusive, correspond to a virtual noise PSD of zero Watt/Hz (minus infinity dBm/Hz).

The maximum number of breakpoints is 32 in the downstream and 16 in the upstream.

The parameter in the downstream direction is TXREFVNds, and the parameter in the upstream direction is TXREFVNus.

NOTE – TXREFVN is configured via the ITU-T G.997.1 parameter VN, whose interpretation depends on the value of SNRM_MODE.

11.4.2.1.2 Use of parameter TXREFVN

The transmitter-referred virtual noise PSD to be used by the transceiver for calculation of the SNR margin for each subcarrier i , shall be obtained by linear interpolation in dB on a linear frequency scale as follows:

$$TX_referred_Virtual_Noise_PSD(i) = PSD_n + (PSD_{n+1} - PSD_n) \times \frac{\left(\frac{i \cdot \Delta f}{Df}\right) - t_n}{t_{n+1} - t_n} \quad t_n < \left(\frac{i \cdot \Delta f}{Df}\right) \leq t_{n+1}$$

where Δf is the actual subcarrier spacing used by the DMT modulation.

In downstream, the breakpoints (t_i, PSD_i) are those communicated to the VTU-R in O-SIGNATURE and are a combination of the configuration parameter TXREFVNds and the configuration parameter TXREFVNSFs as described in clause 11.4.2.5.

In upstream, the breakpoints (t_i, PSD_i) are equal to the breakpoints of the configuration parameter TXREFVNus as in the CO-MIB.

The near-end transceiver should apply the Received_Virtual_Noise_PSD (see clause 11.4.1.1.6.1.2) at the constellation decoder point (i.e., the transceiver does not need to account for DFT leakage effects from one subcarrier to another subcarrier). All effects are to be taken into account in the setting of the TXREFVN in the CO-MIB.

NOTE 1 – The above method is equivalent to the near-end transceiver calculating its bit loading using the following Virtual_Noise_SNR for the subcarrier with index i , at the constellation decoder (all terms are expressed in dB):

$$\text{Virtual_Noise_SNR}(i) = S_{tx}(i) - N_{tx}(i) + 20 \times \log_{10}(g_i)$$

where:

$$S_{tx}(i) = \text{MREFPSD}(i)$$

$$N_{tx}(i) = \text{TX_referred_Virtual_Noise_PSD}(i)$$

and MREFPSD(i) is the MEDLEY reference PSD value at the far-end transmitter for the subcarrier with index i , obtained by interpolation of the breakpoints of the MEDLEY reference PSD (MREFPSD) information exchanged in the O-PRM and R-PRM messages during initialization.

TX_referred_Virtual_Noise_PSD(i) is the transmitter-referred virtual noise PSD value for subcarrier with index i , obtained by interpolation of the breakpoints of TXREFVN sent in the O-SIGNATURE message during initialization.

g_i is the gain adjuster for the subcarrier with index i as defined in clause 10.3.4.

NOTE 2 – Improper setting of TXREFVN can interact with the setting of one or more of the following parameters: maximum net data rate, downstream maximum SNR margin, impulse noise protection, and maximum interleaving delay. This interaction can result in high levels of transmit power that can lead to high crosstalk experienced by DSLs on other pairs in the same binder.

11.4.2.2 INM procedure and control parameters

This clause describes the INM procedure and associated INM control parameters.

11.4.2.2.1 INM procedure

Figure 11-5 shows the INM functional block diagram.

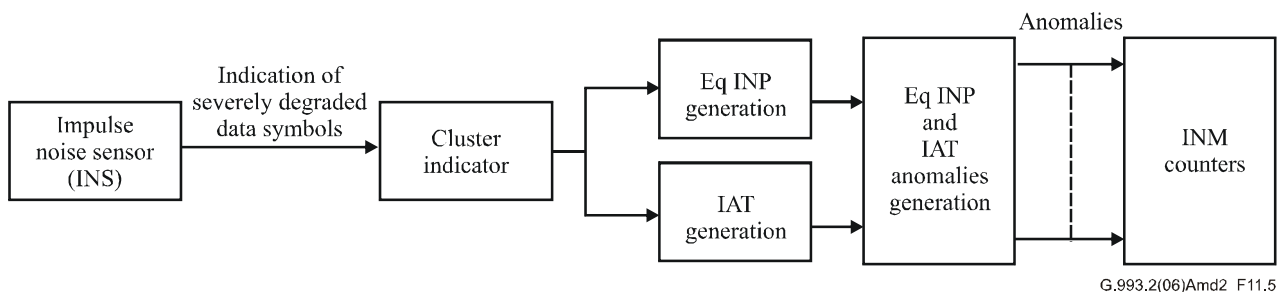

Figure 11-5 – Impulse noise monitor functional block diagram

The impulse noise sensor (INS) indicates whether a data symbol is severely degraded or not. A data symbol is considered to be severely degraded when it would lead to severe errors on the gamma interface when there would be no impulse noise protection (i.e., RS only used for coding gain). The implementation details for this sensor are vendor-discretionary.

NOTE 1 – Performance requirements for the INS are for further study.

If a sync symbol occurs between two data symbols (severely degraded or not), the impulse noise sensor shall disregard it.

NOTE 2 – If a sync symbol occurs between two groups of respectively N1 and N2 consecutive severely degraded data symbols, the two groups will form a single group of consecutive severely degraded data symbols of length N1 + N2 data symbols.

The cluster indicator indicates short groups of severely degraded data symbols as clusters. The cluster can contain a single severely degraded data symbol, a group of consecutive severely degraded data symbols, or several groups of one or more consecutive severely degraded data symbols with gaps between the groups.

The cluster indicator shall use the following rule to identify the cluster. A gap is defined as a group of non-severely degraded data symbols in-between two severely degraded data symbols. A cluster is defined as the largest group of consecutive data symbols, starting and ending with a severely degraded data symbol, containing severely degraded data symbols, separated by gaps smaller than or equal to INMCC (the cluster continuation parameter, see clause 11.4.2.2.4).

As a consequence of the above definition of a cluster, each cluster starts with a severely degraded data symbol preceded by a gap larger than INMCC and ends with a severely degraded data symbol followed by a gap larger than INMCC, while gaps inside the cluster are all smaller than or equal to INMCC.

In the Eq INP generation block, the "equivalent INP" of the cluster is generated. For each cluster, the following characteristics shall be determined:

- The impulse noise cluster length (INCL), defined as the number of data symbols from the first to the last severely degraded data symbol in the cluster.
- The impulse noise cluster degraded data symbols (INCD), defined as the number of severely degraded data symbols in the cluster.
- The impulse noise cluster number of gaps (INCG), defined as the number of gaps in the cluster, with gap as defined above.

Depending on the value of the control parameter INM_INPEQ_MODE, the equivalent INP is generated as:

- INM_INPEQ_MODE = 0: $INP_{eq} = INCL$ with INMCC = 0
- INM_INPEQ_MODE = 1: $INP_{eq} = INCL$ with INMCC as configured (see clause 11.4.2.2.4)
- INM_INPEQ_MODE = 2: $INP_{eq} = INCD$ with INMCC as configured (see clause 11.4.2.2.4)
- INM_INPEQ_MODE = 3:

$$\text{For } INCG < (8 \times \text{erasuregain}): INP_{eq} = \min \left(INCL, \text{ceil} \left[INCD \times \left(\frac{1}{1 - \frac{INCG}{8 \times \text{erasuregain}}} \right) \right] \right)$$

$$\text{For } INCG \geq (8 \times \text{erasuregain}): INP_{eq} = INCL$$

with INMCC as configured (see clause 11.4.2.2.4)

where the erasure gain is defined as:

$$\text{erasuregain} = \frac{INP}{INP_{no_erasure}} \text{ with } INP, \text{ and } INP_{no_erasure} \text{ as defined in clause 9.6.}$$

NOTE 3 – In case the bit "INP_no_erasure_required" (bit 8 in the "impulse noise protection and dynamic interleaver reconfiguration" field in Table 12-51, clause 12.3.5.2.1.1) is set, the erasure gain is equal to 1.

- **INM_INPEQ_MODE = 4:** In this mode, the value of INP_eq shall correspond with the VTU's own estimate (i.e., VTU-R's estimate in the downstream, VTU-O's estimate in the upstream) of the INP_min setting required to provide error-free operation for the cluster, with INMCC as configured (see clause 11.4.2.2.4). The method of computation of the VTU's own estimate is vendor-discretionary. For INM_INPEQ_MODE = 4 only, if INMCC is set to 64, the VTU shall use its own method for cluster indication. If INMCC < 64, the VTU shall use the cluster indicator as described in this clause for the INM_INPEQ_MODE = 1, 2 and 3.

Anomalies are generated for several values of INP_eq, as defined in clause 11.3.4.1. The counters of these anomalies represent the INP_eq histogram.

In the IAT generation block, the inter-arrival time (IAT) is generated as the number of data symbols from the start of a cluster to the start of the next cluster. If sync symbols occur between two clusters, they shall not be counted in the IAT. Anomalies are generated for several ranges of inter arrival time, as defined in clause 11.3.4.3. The counters of these anomalies represent the IAT histogram.

For every data symbol, the total measurement count INMAME is increased by 1.

11.4.2.2.2 Definition of parameter INMIATO

Configuration parameter INMIATO defines the INM inter-arrival time offset for the IAT anomaly generation in order to determine in which bin of the inter-arrival time histogram the IAT is reported (see clause 11.3.4.3).

The CO MIB shall provide the value for the INMIATO parameter. The parameter in the downstream direction is INMIATODs, and the parameter in the upstream direction is INMIATOUS.

The valid values for INMIATO in both directions range from 3 to 511 DMT symbols in steps of 1 DMT symbol. If the VTU supports the INM facility, it shall support all valid values.

Upon entering the first showtime after power-up, the VTU-R shall use a default value of INMIATODs = 3. During showtime, this value may be overwritten by the VTU-O using an INM facility command defined in clause 11.2.3.13. A link state transition shall not affect the INMIATODs value (e.g., not reset the value to the default value).

The VTU-O shall use the current value of INMIATOUS stored in the CO MIB.

11.4.2.2.3 Definition of parameter INMIATS

Configuration parameter INMIATS defines the INM inter-arrival time step for the IAT anomaly generation in order to determine in which bin of the inter-arrival time histogram the IAT is reported (see clause 11.3.4.3).

The CO MIB shall provide the value for the INMIATS parameter. The parameter in the downstream direction is INMIATSDs, and the parameter in the upstream direction is INMIATSUS.

The valid values for INMIATS range from 0 to 7 in steps of 1. If the VTU supports the INM facility, it shall support all valid values.

Upon entering the first showtime after power-up, the VTU-R shall use a default value of INMIATSDs = 0. During showtime, this value may be overwritten by the VTU-O using an INM facility command defined in clause 11.2.3.13. A link state transition shall not affect the INMIATSDs value (e.g., not reset the value to the default value).

The VTU-O shall use the current value of INMIATSUS stored in the CO MIB.

11.4.2.2.4 Definition of parameter INMCC

Configuration parameter INMCC defines the INM cluster continuation value to be used in the cluster indication process described in clause 11.4.2.2.1. If INM_INPEQ_MODE = 0, INMCC is equal to zero, independent of the CO MIB setting. If INM_INPEQ_MODE > 0, the CO MIB shall provide the

value for the INMCC parameter. The parameter in the downstream direction is INMCCds, and the parameter in the upstream direction is INMCCus.

The valid values for INMCC range from 0 to 64 DMT symbols in steps of 1 DMT symbol. If the VTU supports the INM facility, it shall support INMCC = 0. If the VTU supports the INM facility, and supports any INM_INPEQ_MODE > 0, it shall support all valid values.

Upon entering the first showtime after power-up, the VTU-R shall use a default value of INMCCds = 0. During showtime, this value may be overwritten by the VTU-O using an INM facility command defined in clause 11.2.3.13.

A link state transition shall not affect the INMCCds value (e.g., not reset the value to the default value).

The VTU-O shall use the current value of INMCCus stored in the CO MIB.

11.4.2.2.5 Definition of parameter INM_INPEQ_MODE

Configuration parameter INM_INPEQ_MODE defines the way of computation of equivalent INP, as defined in clause 11.4.2.2.1. The CO MIB shall provide the value for the INM_INPEQ_MODE parameter. The parameter in the downstream direction is INM_INPEQ_MODEds, and the parameter in the upstream direction is INM_INPEQ_MODEus.

The valid values for INM_INPEQ_MODE are 0, 1, 2, 3 and 4. If the VTU supports the INM facility, it shall support INM_INPEQ_MODE = 0. All other modes are optional. If the VTU supports any INM_INPEQ_MODE > 0, it shall support at least INM_INPEQ_MODE = 1, 2 and 3.

Upon entering the first showtime after power-up, the VTU-R shall use a default value of INM_INPEQ_MODEds = 0. During showtime, this value may be overwritten by the VTU-O using an INM facility command defined in clause 11.2.3.13.

A link state transition shall not affect the INM_INPEQ_MODE value (e.g., not reset the value to the default value).

The VTU-O shall use the current value of INM_INPEQ_MODEus stored in the CO MIB.

11.4.2.2.6 Definition of parameter INM_INPEQ_FORMAT

Configuration parameter INM_INPEQ_FORMAT defines the way the scale is configured for the INM_INPEQ histogram, as defined in clause 11.3.4.1. The CO MIB shall provide the value for the INM_INPEQ_FORMAT parameter. The parameter in the downstream direction is INM_INPEQ_FORMATds, and the parameter in the upstream direction is INM_INPEQ_FORMATus.

The valid values for INM_INPEQ_FORMAT are 0 and 1. If the VTU supports the INM facility, it shall support INM_INPEQ_FORMAT = 0 and may support INM_INPEQ_FORMAT = 1.

Upon entering the first showtime after power-up, the VTU-R shall use a default value of INM_INPEQ_FORMAT = 0. During showtime, this value may be overwritten by the VTU-O using an INM facility command defined in clause 11.2.3.13 if the VTU-R supports INM_INPEQ_FORMAT = 1.

A link state transition shall not affect the INM_INPEQ_FORMAT value (e.g., not reset the value to the default value).

The VTU-O shall use the current value of INM_INPEQ_FORMATus stored in the CO-MIB.

11.4.2.3 Receiver-referred virtual noise PSD

This clause describes the receiver-referred virtual noise PSD parameter RXREFVN, used only in the optional SNR margin mode SNRM_MODE = 3 and SNRM_MODE=4.

11.4.2.3.1 Definition of parameter RXREFVN

Configuration parameter RXREFVN defines the receiver-referred virtual noise PSD to be used in determining the SNR margin.

For SNRM_MODE=3 and SNRM_MODE=4, the CO-MIB shall provide a RXREFVN parameter set for each utilized band.

The receiver-referred virtual noise PSD in the CO-MIB shall be specified by a set of breakpoints. Each breakpoint shall consist of a subcarrier index t_n and a noise PSD value (expressed in dBm/Hz). The RXREFVN parameter for each band shall be a set of breakpoints that are represented by $[(t_1, PSD_1), (t_2, PSD_2), \dots, (t_n, PSD_n), \dots, (t_{NBP}, PSD_{NBP})]$, where t_1 and t_{NBP} are, respectively, the lower and higher band edge frequencies of the band. The VTU shall ignore any frequency information that does not belong to the utilized (upstream) bands.

The subcarrier indices t_i shall be coded in the CO-MIB as unsigned integers in the range from $t_1 = \text{roundup}(f_x/Df)$ to $t_{NBP} = \text{rounddown}(f_{x+1}/Df)$, where f_x, f_{x+1} are the low and the high band separating frequencies determined by the applied band plan and specified in clause 7.1, and $Df = 4.3125$ kHz. The breakpoints shall be defined so that $t_n < t_{n+1}$ for $n = 1$ to $N - 1$; the frequency f_n corresponding to the index t_n can be found as: $f_n = t_n \times Df$. The value of Df is independent of the subcarrier spacing Δf used for DMT modulation. When the VTU operates with 8.625 kHz subcarrier spacing, all odd values of t_i shall be converted by the VTU, by rounding down to the next lower even value, and values t_1 and t_{NBP} shall be rounded (up and down, respectively) to even values.

The values for the virtual noise PSD shall be coded as 8-bit unsigned integers representing virtual noise PSD values from -40 dBm/Hz (coded as 0) to -140 dBm/Hz (coded as 200), in steps of 0.5 dBm/Hz. Values from 201 to 255, inclusive, correspond to a virtual noise PSD of zero Watt/Hz (minus infinity dBm/Hz).

The maximum number of breakpoints is 16.

The parameter in the upstream direction is RXREFVNus.

NOTE – RXREFVN is configured via the ITU-T G.997.1 parameter VN, whose interpretation depends on the value of SNRM_MODE.

11.4.2.3.2 Use of parameter RXREFVN

For each frequency band, the receiver-referred virtual noise PSD, for each subcarrier i , shall be obtained by linear interpolation in dB on a linear frequency scale as follows:

$$RX_referred_Virtual_Noise_PSD(i) = PSD_n + (PSD_{n+1} - PSD_n) \times \frac{\left(\frac{i * \Delta f}{Df}\right) - t_n}{t_{n+1} - t_n} \quad t_n < \left(\frac{i * \Delta f}{Df}\right) \leq t_{n+1}$$

where Δf is the actual subcarrier spacing used by the DMT modulation.

In SNRM_MODE=3, the breakpoints (t_i, PSD_i) are equal to the breakpoints of the configuration parameter RXREFVNus as in the CO-MIB.

In SNRM_MODE=4, the breakpoints (t_i, PSD_i) are a combination of the configuration parameter RXREFVNus and the configuration parameter RXREFVNSfus as described in clause 11.4.2.4.

The near-end transceiver should apply the Received_Virtual_Noise_PSD (see clause 11.4.1.1.6.1.3) over the upstream frequencies at the constellation decoder point (i.e., the transceiver does not need to account for DFT leakage effects from one subcarrier to another subcarrier). All effects are to be taken into account in the setting of the RXREFVN in the CO-MIB.

NOTE 1 – The above method is equivalent to the near-end transceiver calculating its bit loading using the following Virtual_Noise_SNR for the subcarrier with index i , at the constellation decoder (all terms are expressed in dB):

$$\text{Virtual_Noise_SNR}(i) = S_{rx}(i) - N_{rx}(i)$$

where:

$$S_{tx}(i) = \text{Actual_Received_Signal_PSD} = |H_{\text{RXfilter}}(f)|^2 + \text{Actual_Received_Signal_at_U_interface}$$

$$N_{tx}(i) = \text{Received_Virtual_Noise_PSD} = |H_{\text{RXfilter}}(f)|^2 + \text{RXREFVNSF} + \text{RXREFVNSF}$$

NOTE 2 – Improper setting of RXREFVNSF and RXREFVNSF can interact with the setting of one or more of the following parameters: maximum net data rate, downstream maximum SNR margin, impulse noise protection, and maximum interleaving delay. This interaction can result in high levels of transmit power that can lead to high crosstalk experienced by DSLs on other pairs in the same binder.

11.4.2.4 Receiver-referred virtual noise scaling factor

This clause describes the receiver-referred virtual noise scaling factor parameter RXREFVNSF, used only in the optional SNR margin mode SNRM_MODE = 4.

Configuration parameter RXREFVNSF defines the receiver-referred virtual noise scaling factor to be used together with the receiver-referred virtual noise PSD in determining the SNR margin.

The CO-MIB shall provide an upstream RXREFVNSF parameter when SNRM_MODE = 4.

The values for the receiver-referred virtual noise PSD scaling factor shall be coded as 8-bit signed integers representing scaling factors from -64.0 dB (coded as -128) to 63.5 dB (coded as 127), in steps of 0.5 dB.

The parameter in the upstream direction is RXREFVNSFus.

The VTU-O shall combine the value of the configuration parameter RXREFVNSFus as in the CO-MIB with the value of the configuration parameter RXREFVNS as in the CO-MIB to a control parameter RXREFVNS as follows:

Control parameter RXREFVNS in *dBm/Hz* = configuration parameter RXREFVNS in *dBm/Hz* + configuration parameter RXREFVNSFus in *dB*.

11.4.2.5 Transmitter-referred virtual noise scaling factor

This clause describes the transmitter-referred virtual noise scaling factor parameter TXREFVNSF, used only in the optional SNR margin mode SNRM_MODE = 4.

Configuration parameter TXREFVNSF defines the transmitter-referred virtual noise scaling factor to be used together with the transmitter-referred virtual noise PSD in determining the SNR margin.

The CO-MIB shall provide a TXREFVNSF parameter for downstream when SNRM_MODE = 4.

The values for the receiver-referred virtual noise PSD scaling factor shall be coded as 8-bit signed integers representing scaling factors from -64.0 dB (coded as -128) to +63.5 dB (coded as +127), in steps of 0.5 dB.

The parameter in the downstream direction is TXREFVNSFds.

The VTU-O shall combine the value of the configuration parameter TXREFVNSFds as in the CO-MIB with the value of the configuration parameter TXREFVNS as in the CO-MIB to a control parameter TXREFVNS as communicated to the VTU-R in O-SIGNATURE as follows:

Control parameter TXREFVNS in *dBm/Hz* = $\min(\max(\text{configuration parameter TXREFVNS in } dBm/Hz + \text{configuration parameter TXREFVNSFds in } dB), -140 \text{ } dBm/Hz), -40 \text{ } dBm/Hz)$.

11.4.2.6 Re-Initialization Policy parameters

11.4.2.6.1 Re-Initialization Policy Selection (RIPOLICY)

The RIPOLICY configuration parameter (see clause 7.3.1.1.12 of [ITU-T G.997.1]) indicates which policy shall be applied to determine the triggers for re-initialization in a specific direction. The

parameter in the downstream direction is *RIPOLICY_{ds}*, and the parameter in the upstream direction is *RIPOLICY_{us}*.

The control parameter *RIpolicy_{ds_n}* shall have the same value as the configuration parameter *RIPOLICY_{ds}* in the CO-MIB for all downstream bearer channels. However, if configuration parameter *RIPOLICY_{ds}*=1 and the VTU-R indicates during ITU-T G.993.2 initialization in R-MSG 2 (see clause 12.3.5.2.2.1) that *RIpolicy_{ds_n}*=1 is not supported for a particular bearer channel, the VTU-O shall fall back to indicate *RIpolicy_{ds_n}*=0 in O-TPS (see clause 12.3.5.2.1.2) for that bearer channel.

The control parameter *RIpolicy_{us_n}* shall have the same value as the configuration parameter *RIPOLICY_{us}* in the CO-MIB for all upstream bearer channels. However, if *RIpolicy_{us_n}*=1 is not supported by the VTU-O for a particular bearer channel, the VTU-O shall fall back to *RIpolicy_{us_n}*=0 for that bearer channel.

The valid values for *RIPOLICY* are 0 and 1.

11.4.2.6.2 REINIT_TIME_THRESHOLD

Configuration parameter *REINIT_TIME_THRESHOLD* (see clause 7.3.1.1.13 of [ITU-T G.997.1]) defines the threshold for re-initialization based on SES, to be used by the VTU receiver when Re-Initialization Policy 1 is used (see clause 12.1.4).

The downstream and upstream values of *REINIT_TIME_THRESHOLD* shall be configured in the CO-MIB. The parameter in the downstream direction is *REINIT_TIME_THRESHOLD_{ds}*, and the parameter in the upstream direction is *REINIT_TIME_THRESHOLD_{us}*.

The control parameter *REINIT_TIME_THRESHOLD_{ds}* conveyed in O-MSG 1 shall have the same value as the configuration parameter *REINIT_TIME_THRESHOLD_{ds}* in the CO-MIB. The control parameter *REINIT_TIME_THRESHOLD_{us}* shall have the same value as the configuration parameter *REINIT_TIME_THRESHOLD_{us}* in the CO-MIB.

The value shall be coded as an unsigned integer representing the maximum number of SES. The valid range is from 5 to 31.

11.4.2.7 MAXDELAYOCTET-split (MDOSPLIT)

The line configuration parameter *MAXDELAYOCTET-split (MDOSPLIT)* defines the percentage of the *MAXDELAYOCTET* allocated to the downstream direction. All of the remaining *MAXDELAYOCTET* shall be allocated for use in the upstream direction.

MAXDELAYOCTET is the parameter "aggregate interleaver and de-interleaver delay", in octets, specified in Table 6-1 for the profile. A single *MAXDELAYOCTET-split* parameter is defined. The allocated number of octets shall be the total allocated to a given transmission direction for interleaving, and for all latency paths.

Configuration of a split in percentage would result in fractional octets. Therefore, the following rounding rule shall apply ($\lceil x \rceil$ denotes rounding to the higher integer):

$$\text{MAXDELAYOCTET_DS} = \lceil \text{MDOSPLIT} \times \text{MAXDELAYOCTET} \rceil$$

$$\text{MAXDELAYOCTET_US} = \text{MAXDELAYOCTET} - \text{MAXDELAYOCTET_DS}$$

The number of octets used in downstream direction (aggregated over both transceivers) shall be no higher than *MAXDELAYOCTETS_DS*. The number of octets used in upstream direction (aggregated over both transceivers) shall be no higher than *MAXDELAYOCTETS_US*.

The sum of the *max_delay_octet* values specified in O-PMS (see clause 12.3.5.2.1.3) shall be limited to:

$$\text{max_delay_octet}_{\text{DS},0} + \text{max_delay_octet}_{\text{DS},1} \leq \text{MAXDELAYOCTETS_DS}$$

$$\max_delay_octet_{US,0} + \max_delay_octet_{US,1} \leq \text{MAXDELAYOCTETS_US}$$

The above constraints depend only on the MAXDELAYOCTET-split parameter configured through the CO-MIB. The VTU-O shall not re-distribute the allocated max_delay_octets over downstream and upstream directions based on line conditions. As a result, some octets allocated to a given direction may remain unused.

In case of dual latency (i.e., two bearer channels each in a different latency path), the VTU-O shall determine the max_delay_octet values allocated to each of the latency paths to optimize the data rate within the constraint given by the Rate Adaptation Ratio parameter defined in clause 7.3.2.1.4 of [ITU-T G.997.1].

MDOSPLIT shall be expressed as a percentage, with valid range from 5 percent to 95 percent inclusive, in steps of 1 percent. The value 0% is valid only if the maximum downstream interleaving delay is configured with the special value S1 (see clause 7.3.2.2 of [ITU-T G.997.1]). The value 100% is valid only if the maximum upstream interleaving delay is configured with the special value S1 (see clause 7.3.2.2 of [ITU-T G.997.1]). A special value shall indicate that the VTU-O is allowed to use a vendor discretionary algorithm to determine the max_delay_octet values specified in O-PMS.

NOTE – A special value is introduced to ensure backward compatibility.

11.4.2.8 ATTNDR_MAXDELAYOCTET-split (ATTNDR_MDOSPLIT)

The line configuration parameter ATTNDR_MAXDELAYOCTET-split (ATTNDR_MDOSPLIT) defines the percentage of the MAXDELAYOCTET allocated to the downstream direction to be used in the calculation of the ATTNDR. All of the remaining MAXDELAYOCTET shall be allocated for use in the upstream direction.

MAXDELAYOCTET is the parameter "aggregate interleaver and de-interleaver delay", in octets, specified in Table 6-1 for the profile. A single ATTNDR_MDOSPLIT parameter is defined. The allocated number of octets shall be the total allocated to a given transmission direction for interleaving, and for all latency paths.

Configuration of a split in percentage would result in fractional octets. Therefore, the following rounding rule shall apply ($\lceil x \rceil$ denotes rounding to the higher integer):

$$\text{ATTNDR_MAXDELAYOCTET_DS} = \lceil \text{ATTNDR_MDOSPLIT} \times \text{MAXDELAYOCTET} \rceil$$

$$\text{ATTNDR_MAXDELAYOCTET_US} = \text{MAXDELAYOCTET} - \text{ATTNDR_MAXDELAYOCTET_DS}$$

The number of octets used in downstream direction (aggregated over both transceivers) shall be no higher than ATTNDR_MAXDELAYOCTET_DS. The number of octets used in upstream direction (aggregated over both transceivers) shall be no higher than ATTNDR_MAXDELAYOCTET_US.

If the ATTNDR calculation uses single latency mode, the ATTNDR_max_delay_octet values shall be defined as:

$$\text{ATTNDR_max_delay_octet}_{DS,0} = \text{ATTNDR_MAXDELAYOCTET_DS}$$

$$\text{ATTNDR_max_delay_octet}_{US,0} = \text{ATTNDR_MAXDELAYOCTET_US}$$

where the ATTNDR_max_delay_octet_{DS,0} specifies the maximum of delay_octet_{DS,0} that the VTU-R shall assume in the calculation of ATTNDR in downstream (see clause 12.3.5.2.1.3),

and the ATTNDR_max_delay_octet_{US,0} specifies the maximum of delay_octet_{US,0} that the VTU-O shall assume in the calculation of ATTNDR in upstream.

If the ATTNDR calculation uses single latency with ROC mode, the ATTNDR_max_delay_octet values shall be defined as:

$$\text{ATTNDR_max_delay_octet}_{DS,1} = \text{ATTNDR_MAXDELAYOCTET_DS} - \text{delay_octet}_{DS,0}$$

$$\text{ATTNDR_max_delay_octet}_{US,1} = \text{ATTNDR_MAXDELAYOCTET_US} - \text{delay_octet}_{US,0}$$

where the $\text{delay_octet}_{\text{DS},0}$ and $\text{delay_octet}_{\text{US},0}$ values correspond to the actual configuration of the latency path #0 as applicable at the instant of ATTNDR calculation,

and the $\text{ATTNDR_max_delay_octet}_{\text{DS},1}$ specifies the maximum of $\text{delay_octet}_{\text{DS},1}$ that the VTU-R shall assume in the calculation of ATTNDR in downstream (see clause 12.3.5.2.1.3),

and the $\text{ATTNDR_max_delay_octet}_{\text{US},1}$ specifies the maximum of $\text{delay_octet}_{\text{US},1}$ that the VTU-O shall assume in the calculation of ATTNDR in upstream.

The above constraints depend only on the ATTNDR_MDOSPLIT parameter configured through the CO-MIB.

ATTNDR_MDOSPLIT shall be expressed as a percentage, with valid range from 5 per cent to 95 per cent inclusive, in steps of 1 per cent. The value 0% is valid only if the maximum downstream interleaving delay is configured with the special value S1 (see clause 7.3.2.2 of [ITU-T G.997.1]). The value 100% is valid only if the maximum upstream interleaving delay is configured with the special value S1 (see clause 7.3.2.2 of [ITU-T G.997.1]). A special value shall indicate that the VTU-O is allowed to use a vendor discretionary algorithm to determine the $\text{ATTNDR_max_delay_octet}$ values specified in O-PMS.

11.5 Data gathering function

The data gathering function stores records in a buffer, with each record entered in the buffer upon occurrence of a particular event type. These records may be used for diagnosing troubles and analysing functions. Different event types are defined; these are relevant to the operation of the line and are useful for determining what is functioning properly or what is not. Each event is recorded with a timestamp, the ID of the event type, and additional event data as defined for each event type.

The VTU-O may optionally support the data gathering function. If supported, then the data gathering function shall comply with this clause, as applicable to the VTU-O.

The VTU-R may optionally support the data gathering function. If supported, then the data gathering function shall comply with this clause, as applicable to the VTU-R.

The data gathering function uses both the ITU-T G.993.2 transceiver functionality and the ITU-T G.997.1 functionality. Support of some ITU-T G.997.1 functionality is required to implement this clause. The data gathering function shall include a buffer of logging_depth records. Each record shall include the following three fields: Event Timestamp, Event Type and Event Data.

For each event type, a logging depth is defined as the minimum number of records of the event type that shall be kept in the buffer when deleting entries of this event type in case of buffer full condition. Per event type, the logging depth shall be configurable as a parameter derived from the configuration parameter $\text{logging_depth_event_percentage}_i$ as follows:

$$\text{logging_depth_event}_i = \lfloor (\text{logging_depth_event_percentage}_i / 100\%) \times \text{logging_depth} \rfloor$$

The sum over all event types of the configured $\text{logging_depth_event_percentage}_i$ shall not exceed 100%, i.e.,

$$\sum_i \text{logging_depth_event_percentage}_i \leq 100\%$$

NOTE – If the sum of $\text{logging_depth_event}_i$ is smaller than logging_depth , then the remaining part of the buffer is used as a pool that can be used for any event type, within the buffer management rules defined in clause 11.5.2.

The control parameter, $\text{logging_depth_event}_i$, is the minimum logging depth for event type i in number of 6-byte records, i.e., $\text{logging_depth_event}_i$ is the minimum number of records of event type i that shall be kept in the event buffer of the VTU. This is logically the same as having a separate

buffer for each event type, with each of these buffers able to store at least *logging_depth_event_i* records.

The maximum depth of the entire event buffer is reported by the VTU as *logging_depth*.

The parameter *logging_depth* is defined separately for the VTU-R and the VTU-O respectively as *logging_depth_R* and *logging_depth_O*. The reporting parameter *logging_depth_R* is the maximum depth of the buffer stored at the VTU-R and is reported in the CO-MIB as LOGGING_DEPTH_R (see clause 7.5.3.2 of [ITU-T G.997.1]). The reporting parameter *logging_depth_O* is the maximum depth of the buffer stored at the VTU-O and is reported in the CO-MIB as LOGGING_DEPTH_O (see clause 7.5.3.1 of [ITU-T G.997.1]).

The control parameter *logging_depth_event_percentage_i* is defined separately for the VTU-R and the VTU-O respectively as *logging_depth_event_percentage_R_i* and *logging_depth_event_percentage_O_i*. The control parameter *logging_depth_event_percentage_R_i* shall have a value equal to the CO-MIB configuration parameter LOGGING_DEPTH_EVENT_PERCENTAGE_R_i (see clause 7.3.6.2 of [ITU-T G.997.1]). The control parameter *logging_depth_event_percentage_O_i* shall have a value equal to the CO-MIB configuration parameter LOGGING_DEPTH_EVENT_PERCENTAGE_O_i (see clause 7.3.6.1 of [ITU-T G.997.1]).

At the VTU-O and VTU-R, the record length shall be fixed at 6 bytes (consisting of 4 bytes for the timestamp, 1 byte for the Event Type, and 1 byte for the Event Data).

At the VTU-O, the timestamps as presented at the Q-interface (towards the MIB) shall be the number of seconds since Jan 1, 1900 as defined in [IETF RFC 5905] (NTP) coded in a 32-bit format. At the VTU-R, the timestamp as presented towards the U-interface (on the DSL) shall be the number of seconds since the last power cycle (mains power turned off/on) of the VTU-R, coded in a 32-bit format (with accuracy of time clock within ± 50 ppm). The VTU-R timestamp shall be recorded in the CO-MIB in the same format as it presented toward the U-interface.

A single record of each event type shall be stored once each second, unless no event of this type occurred during that second. In case an event (with a particular event ID, as per Table 11-43) has occurred multiple times during a one-second period, a single event shall be recorded with the timestamp for that one second period, and within this record the number of occurrences of the event may be reflected as part of the Event Data.

The following subclauses identify which event types shall be supported by the VTU-O and/or VTU-R. The reporting of all supported event types is mandatory, i.e., there are no event types that are optionally supported.

Clause 11.5.2 defines the buffer management rules.

Clause 11.2.3.16 defines the mechanism for the VTU-O to retrieve over the eoc channel the data gathered in the VTU-R buffer.

The logging depth that is applied for reporting the VTU-R buffer over the eoc channel is *logging_depth_reporting*.

The VTU-O shall set *act_logging_depth_reporting_R* in the eoc configuration command message. The *act_logging_depth_reporting_R* shall be the minimum of:

- the *logging_depth_R* (indicated by the VTU-R in the eoc configuration response message);
- the maximum depth of the buffer at the VTU-O that stores the records originated at the VTU-R as reported over the eoc channel;
- the CO-MIB configuration parameter LOGGING_DEPTH_REPORTING_R (see clause 7.3.6.4 of [ITU-T G.997.1]).

When sending a first configuration command, the VTU-O is not aware of the *logging_depth_R*. If the configuration command message indicates an *act_logging_depth_reporting_R* that is higher than *logging_depth_R*, then the VTU-R shall send a NACK response, and the VTU-O shall send a new configuration command to satisfy the above three conditions.

The control parameter *act_logging_depth_reporting_R* is reported in the CO-MIB as ACT_LOGGING_DEPTH_REPORTING_R (see clause 7.5.3.4 of [ITU-T G.997.1]).

The VTU-O shall set *act_logging_depth_reporting_O*. The *act_logging_depth_reporting_O* shall be the minimum of:

- the *logging_depth_O*;
- the CO-MIB configuration parameter LOGGING_DEPTH_REPORTING_O (see clause 7.3.6.3 of [ITU-T G.997.1]).

The control parameter *act_logging_depth_reporting_O* is reported in the CO-MIB as ACT_LOGGING_DEPTH_REPORTING_O (see clause 7.5.3.3 of [ITU-T G.997.1]).

If *act_logging_depth_reporting_R* is strictly less than *logging_depth_R*, then the VTU-R may store more than *act_logging_depth_reporting_R* records. In this case however, the VTU-R shall virtually reduce the number of stored records to no more than *act_logging_depth_reporting_R* records by applying the buffer management rules of clause 11.5.2 before reporting records over the eoc channel. For the data gathering functionality defined in this Recommendation, the term "VTU-R buffer" shall refer to the storage of up to *act_logging_depth_reporting_R* records.

Upon a power cycle, the VTU-R:

- shall reset the entire buffer by setting all records to be dummy records, where a dummy record is defined as a record which has all fields set to the value 0, and,
- shall set *Nnack* = 0, and,
- shall start data gathering with a reset of the timestamp to value 0, *act_logging_depth_reporting_R* = *logging_depth_R* and *logging_depth_percentage_Ri* = 0 for all event types (i.e., the VTU-R buffer operates as a pure FIFO until the *logging_depth_reporting* and *logging_depth_event_percentage_Ri* are configured).

A VTU-R supporting the data gathering functionality shall support the "previous-loss-of-power" (PLPR) flag.

The records originated at the VTU-R (and reported to the VTU-O over the eoc channel) are contained in the CO-MIB parameter EVENT_TRACE_BUFFER_R (see clause 7.5.3.6 of [ITU-T G.997.1]). The maximum number of records contained in this CO-MIB parameter is ACT_LOGGING_DEPTH_REPORTING_R (see clause 7.5.3.4 of [ITU-T G.997.1]). In the case that the number of records contained in this CO-MIB parameter is less than ACT_LOGGING_DEPTH_REPORTING_R, the remainder of the EVENT_TRACE_BUFFER_R shall be set to all dummy records.

The records originated at the VTU-O are contained in the CO-MIB parameter EVENT_TRACE_BUFFER_O (see clause 7.5.3.5 of [ITU-T G.997.1]). The maximum number of records contained in this CO-MIB parameter is ACT_LOGGING_DEPTH_REPORTING_O (see clause 7.5.3.3 of [ITU-T G.997.1]). In the case that the number of records contained in this CO-MIB parameter is less than ACT_LOGGING_DEPTH_REPORTING_O, the remainder of the EVENT_TRACE_BUFFER_O shall be set to all dummy records.

11.5.1 Event types and event data

Table 11-43 lists the event types defined for the data gathering function and the identifier that shall be used in the record to identify the event type. Table 11-43 also indicates whether the event type

shall be supported by the VTU-O and/or VTU-R (M indicates "mandatory support" and O indicates "optional support").

Table 11-43 – List of Event types

Event type	ID	VTU-O	VTU-R	Definition
Dummy	00 ₁₆	M	M	See clause 11.5
End of Showtime	01 ₁₆	M	M	See clause 11.5.1.1
Previous End Of Showtime	02 ₁₆	M	M	See clause 11.5.1.2
Failed Init	03 ₁₆	M	M	See clause 11.5.1.3
Successful Init	04 ₁₆	M	M	See clause 11.5.1.4
Downstream Init Net Data Rate	05 ₁₆	M	M	See clause 11.5.1.5
Upstream Init Net Data Rate	06 ₁₆	M	M	See clause 11.5.1.6
Line Failure	07 ₁₆	M	M	See clause 11.5.1.7
CRC-8 Anomalies	08 ₁₆	M	M	See clause 11.5.1.8
OLR	09 ₁₆	M	M	See clause 11.5.1.9
Bitswap	0A ₁₆	M	M	See clause 11.5.1.10
Downstream Net Data Rate After Successful SRA	0B ₁₆	M	M	See clause 11.5.1.11
Upstream Net Data Rate After Successful SRA	0C ₁₆	M	M	See clause 11.5.1.12
Downstream Net Data Rate After Successful SOS	0D ₁₆	M	M	See clause 11.5.1.13
Upstream Net Data Rate After Successful SOS	0E ₁₆	M	M	See clause 11.5.1.14
Defect	0F ₁₆	M	M	See clause 11.5.1.15
Retransmission Event	10 ₁₆	M	M	See clause 11.5.1.16
Reserved for use by ITU-T	11 ₁₆ to 7F ₁₆			
Vendor-discretionary event types	80 ₁₆ to FF ₁₆			
NOTE – Event types that are optional in this Recommendation are mandatory for the data gathering function only if the particular event type is supported by the VTU.				

11.5.1.1 Event type "End of Showtime"

The event type "End of Showtime" shall occur when the VTU transitions from the SHOWTIME state to the SILENT state (see VTU-O state diagram in Figure 12-2 and VTU-R state diagram in Figure 12-3). The related event data shall identify the trigger issued at VTU-O or VTU-R for this transition.

Table 11-44 lists the event data, and the identifier that shall be used in the record to identify the event data. Table 11-44 also indicates whether the event data shall be supported by the VTU-O and/or VTU-R (M indicates "mandatory support" and R11 indicates "mandatory only if $R1policy_n=1$ ".)

Table 11-44 – Event data for event type "End of Showtime"

Event data	ID	VTU-O	VTU-R	Definition
Reserved for future use	00 ₁₆			
VTU-O host triggered re-initialization	01 ₁₆	M	M	L3_request and L3_grant in Figure 12-2
VTU-R host triggered re-initialization	02 ₁₆	M	M	L3_request and L3_grant in Figure 12-3
Persistent ne-LOS	03 ₁₆	M	M	See clause 12.1.4
Persistent ne-LOF	04 ₁₆	M	M	See clause 12.1.4
Contiguous ne-SES	05 ₁₆	M	M	See Table 12-4 (Note 2)
Persistent ne-LOM	06 ₁₆	M	M	See clause 12.1.4
Persistent ne-TPS-TC out-of-sync	07 ₁₆	M	M	See clause 12.1.4
MAX-SOS	08 ₁₆	M	M	See Table 12-3
SOS rate low timeout	09 ₁₆	M	M	See Table 12-3
EOC no response	0A ₁₆	M	M	See Table 12-3
Other vendor specific VTU-O or VTU-R near-end conditions declaring a high_BER event	0B ₁₆	M	M	See Table 12-3 (Note 1)
Other vendor specific VTU-O or VTU-R far-end conditions declaring a high_BER event	0C ₁₆	M	M	See Table 12-3 (Note 1)
High BER-hs event as defined for $Rlpolicy_n=1$	0D ₁₆	RI1	RI1	See Table 12-4
Reserved for use by ITU-T	0E ₁₆ to FF ₁₆			
NOTE 1 – This event data ID shall only be used with $Rlpolicy_n = 0$.				
NOTE 2 – Only if $Rlpolicy_n=1$, Table 12-4 defines this event data, otherwise it is vendor specific.				

11.5.1.2 Event type "Previous End of Showtime"

The event type "Previous End of Showtime" shall occur when the VTU enters the SHOWTIME state (see VTU-O state diagram in Figure 12-2 and VTU-R state diagram in Figure 12-3) and the VTU-R has an initialization flag set to 1 (see clause 11.2.3.6). The purpose of this event is to indicate that the previous end of showtime was due to a power cycle or host reinit at the VTU-R. This is important because the VTU-R's timestamp is reset when either of these actions occurs. The related event data shall represent the initialization flag set at the VTU-R (PLPR and PHPR as indicated by the VTU-R in the inventory commands and response, see clause 11.2.3.6).

Table 11-45 lists the event data, and the identifier that shall be used in the record to identify the event data. Table 11-45 also indicates whether the event data shall be supported by the VTU-O and/or VTU-R (M indicates "mandatory support" and NA indicates "not applicable").

Table 11-45 – Event data for event type "Previous End of Showtime"

Event data	ID	VTU-O	VTU-R	Definition
Reserved for future use	00 ₁₆			
Previous-loss-of-power (PLPR)	01 ₁₆	NA	M	See clause 11.2.3.6
Previous-host-reinit (PHRI)	02 ₁₆	NA	M	See clause 11.2.3.6
Reserved for use by ITU-T	03 ₁₆ to FF ₁₆			
NOTE – The timestamp for this Event Type is recorded immediately after the VTU-R is re-initialized.				

11.5.1.3 Event type "Failed Init"

The event type "Failed Init" shall occur when the VTU transitions from the INIT/TRAIN or INIT/HS state to the SILENT state (see VTU-O state diagram in Figure 12-2 and VTU-R state diagram in Figure 12-3). The related event data shall identify the last initialization phase the VTU-O or VTU-R entered before the initialization failed, e.g., Channel Discovery Phase.

Table 11-46 lists the event data, and the identifier that shall be used in the record to identify the event data. Table 11-46 also indicates whether the event data shall be supported by the VTU-O and/or VTU-R (M indicates "mandatory support"). The octet specifying the event data for this event type is split in half, with the four MSB defining in which phase the initialization failed, and the four LSB specifying the initialization failure cause. The initialization failure cause shall be as defined in clause 7.5.1.6 of [ITU-T G.997.1] and shall be coded as a 4-bit unsigned integer (as shown in Table 11-45).

Table 11-46 – Event data for event type "Failed Init"

Event data	Four MSB of ID	VTU-O	VTU-R	Definition
Reserved for use by ITU-T	0 ₁₆			
ITU-T G.994.1 phase	1 ₁₆	M	M	See Figure 12-5
Channel Discovery phase	2 ₁₆	M	M	See Figure 12-5
Training phase	3 ₁₆	M	M	See Figure 12-5
Channel Analysis and Exchange phase	4 ₁₆	M	M	See Figure 12-5
Reserved for future use	5 ₁₆ to F ₁₆			
Event data	Four LSB of ID	VTU-O	VTU-R	Definition
Successful	0 ₁₆	M	M	See clause 7.5.1.6 of [ITU-T G.997.1]
Configuration error	1 ₁₆	M	M	See clause 7.5.1.6 of [ITU-T G.997.1]
Configuration not feasible on the line	2 ₁₆	M	M	See clause 7.5.1.6 of [ITU-T G.997.1]
Communication problem	3 ₁₆	M	M	See clause 7.5.1.6 of [ITU-T G.997.1]
No peer xTU detected	4 ₁₆	M	M	See clause 7.5.1.6 of [ITU-T G.997.1]
Any other or unknown initialization failure cause	5 ₁₆	M	M	See clause 7.5.1.6 of [ITU-T G.997.1]

Table 11-46 – Event data for event type "Failed Init"

ITU-T G.998.4 retransmission mode was not selected while RTX_MODE = FORCED or with RTX_MODE = RTX_TESTMODE	6 ₁₆	M	M	See clause 7.5.1.6 of [ITU-T G.997.1]
Reserved for use by ITU-T	7 ₁₆ to F ₁₆			

11.5.1.4 Event type "Successful Init"

The event type "Successful Init" shall occur when the VTU transitions from the INIT/TRAIN to the SHOWTIME state (see VTU-O state diagram in Figure 12-2 and VTU-R state diagram in Figure 12-3). The related event data shall be the number of the bit to be set in xTU Transmission System Enabling (XTSE) as defined in clause 7.3.1.1.1 of [ITU-T G.997.1] for the representation of the transmission system type. For example, Event Data = 39₁₆ (57 decimal) is ITU-T G.993.2 Region A (North America) (Annex A).

Table 11-47 lists the event data, and the identifier that shall be used in the record to identify the event data. Table 11-47 also indicates whether the event data shall be supported by the VTU-O and/or VTU-R (M indicates "mandatory support").

Table 11-47 – Event data for event type "Successful Init"

Event data	ID	VTU-O	VTU-R	Definition
Reserved for use by ITU-T	00 ₁₆			
Transmission system type	01 ₁₆ to 40 ₁₆	M	M	
Reserved for use by ITU-T	41 ₁₆ to FF ₁₆			
NOTE – This event may be used to correlate the timestamps in the VTU-O and VTU-R buffers.				

11.5.1.5 Event type "Downstream Init Net Data Rate"

The event type "Downstream Init Net Data Rate" shall occur when the VTU transitions from the INIT/TRAIN to the SHOWTIME state (see VTU-O state diagram in Figure 12-2 and VTU-R state diagram in Figure 12-3). The related event data shall identify the downstream net data rate applicable at the instant of entry into SHOWTIME.

The Downstream Init Net Data Rate (NDR) shall be recorded in the Event Data as an index, represented as an unsigned single octet integer, which shall be the integer value closest to:

$$63 \times \log_{10} \left(\frac{NDR}{0.2 \text{ Mbit/s}} \right) + 1, \text{ with } 1 \leq \text{index} \leq 253 \text{ for } 0.2 \text{ Mbit/s} \leq NDR \leq 2000 \text{ Mbit/s}.$$

If $NDR \leq 0.2 \text{ Mbit/s}$, then the index shall be 0. If $NDR \geq 2000 \text{ Mbit/s}$, then index shall be 254. The index value 255 shall be reserved.

NOTE – This results in 3.7% granularity between recordable downstream net data rates.

11.5.1.6 Event type "Upstream Init Net Data Rate"

The Event Type "Upstream Init Net Data Rate" shall occur when the VTU transitions from the INIT/TRAIN to the SHOWTIME state (see VTU-O state diagram in Figure 12-2 and VTU-R state diagram in Figure 12-3). The related Event Data shall identify the upstream net data rate applicable at the instant of entry into SHOWTIME.

The Upstream Init Net Data Rate shall be recorded in the Event Data in the same way as the Downstream Init Net Data Rate (see clause 11.5.1.5).

11.5.1.7 Event type "Line Failure"

The event type "Line Failure" shall occur every time instant when one or more near-end Line Failures occurs or terminates (see Table 7-10 of [ITU-T G.997.1]). These line failures may or may not result in a retrain. The related event data shall consist of a bitmap identifying each of the line failures, which can simultaneously record multiple types of Line failures. The event data indicates whether each line failure initially occurs or terminates in the reported second. If there are no line failures occurring or terminating in this second, then this event is not recorded.

Line failures are generated by the ITU-T G.997.1 functionality (see Figure 7-1 of [ITU-T G.997.1]). Therefore, the data gathering functionality gathers records from both the transceiver functionality and the ITU-T G.997.1 functionality.

Table 11-48 lists the Event Data, and the identifier that shall be used in the record to identify the Event Data. Table 11-48 also indicates whether the event data shall be supported by the VTU-O and/or VTU-R (M indicates "mandatory support").

Table 11-48 – Event data for event type "Line Failure"

Event Data	ID	VTU-O	VTU-R	Definition
LOS occurs	0 0 x x x x x 1	M	M	See clause 7.1.1.1.1 of [ITU-T G.997.1]
LOS terminates	0 0 x x x x 1 x	M	M	See clause 7.1.1.2.1 of [ITU-T G.997.1]
LOF occurs	0 0 x x x 1 x x	M	M	See clause 7.1.1.1.2 of [ITU-T G.997.1]
LOF terminates	0 0 x x 1 x x x	M	M	See clause 7.1.1.2.2 of [ITU-T G.997.1]
LPR occurs	0 0 x 1 x x x x	M	M	See clause 7.1.1.1.3 of [ITU-T G.997.1]
LPR terminates	0 0 1 x x x x x	M	M	See clause 7.1.1.2.3 of [ITU-T G.997.1]
NOTE – Event Data denoted by "occurs" indicate the first occurrence of the event in a contiguous series.				

11.5.1.8 Event type "CRC-8 Anomalies"

The event type "CRC-8 Anomaly" records one or more contiguous seconds with CRC-8 anomalies at the near-end (see clause 9.5.2.3). The Event Data shall consist of a bitmap identifying the start and end of the CRC-8 anomalies at the near-end, which can simultaneously record multiple CRC-8 starting and ending events. For this Event Type; event data "1 or more CRC-8s anomalies per second started" shall occur at the first occurrence of a contiguous series of seconds with one or more CRC-8 anomalies; event data "1 or more CRC-8s anomalies per second ended" shall occur in the second immediately following the last occurrence of a contiguous series of seconds with one or more CRC-8 anomalies; event data "18 or more normalized CRC-8s anomalies per second started" shall occur at the first occurrence of a contiguous series of seconds with 18 or more normalized CRC-8 anomalies; and event data "18 or more normalized CRC-8s anomalies per second ended" shall occur in the second immediately following the last occurrence of a contiguous series of seconds with 18 or more normalized CRC-8 anomalies.

Table 11-49 lists the event data, and the identifier that shall be used in the record to identify the event data. Table 11-49 also indicates whether the Event Data shall be supported by the VTU-O and/or VTU-R (M indicates "mandatory support").

Table 11-49 – Event data for event type "CRC-8 Anomalies"

Event data	ID	VTU-O	VTU-R	Definition
One or more CRC-8s anomalies per second starts	0 0 0 0 x x 0 1	M	M	See clause 9.5.2.3
One or more CRC-8s anomalies per second ended	0 0 0 0 x x 1 0	M	M	See clause 9.5.2.3
18 or more normalized CRC-8s anomalies per second starts	0 0 0 0 0 1 x x	M	M	See clause 9.5.2.3
18 or more normalized CRC-8s anomalies per second ended	0 0 0 0 1 0 x x	M	M	See clause 9.5.2.3
NOTE – One or more CRC-8 anomalies per second is one possible cause of an ES-L (see clause 7.2.1.1.2 of [ITU-T G.997.1]). 18 or more normalized CRC-8 anomalies per second is one possible cause of an SES-L (see clause 7.2.1.1.3 of [ITU-T G.997.1]).				

11.5.1.9 Event type "OLR"

The Event Type "OLR" shall occur when an (sent or received) OLR command is deferred, rejected or positively acknowledged (i.e., successful) (see clause 13.1) and when no response to a sent OLR command is received within the specified time period (i.e., failed) (see Table 11-1). The related event data shall identify the result of the OLR procedure. Table 11-50 lists the event data, and the identifier that shall be used in the record to identify the Event Data. If there is one or more events with a given event data in this second, then the indicator bit corresponding to that event data is set to 1; the indicator bit is set to 0 otherwise. Multiple instances of different event data for this event that occur during the same second shall be recorded by setting multiple indicator bits to 1 as indicated in Table 11-50.

Table 11-50 also indicates whether the event data shall be supported by the VTU-O and/or VTU-R (M indicates "mandatory support").

Table 11-50 – Event data for event type "OLR"

Event data	ID	VTU-O	VTU-R	Definition
Successful SRA downstream	x x x x x x x 1	M	M	See clause 13.1
Failed, deferred, or rejected SRA downstream	x x x x x x 1 x	M (see Note 1)	M	See clause 13.1
Successful SRA upstream	x x x x x 1 x x	M	M	See clause 13.1
Failed, deferred, or rejected SRA upstream	x x x x 1 x x x	M	M (see Note 1)	See clause 13.1
Successful SOS downstream	x x x 1 x x x x	M	M	See clause 13.1
Failed, deferred, or rejected SOS downstream	x x 1 x x x x x	M (see Note 1)	M	See clause 13.1
Successful SOS upstream	x 1 x x x x x x	M	M	See clause 13.1

Table 11-50 – Event data for event type "OLR"

Event data	ID	VTU-O	VTU-R	Definition
Failed, deferred, or rejected SOS upstream	1 x x x x x x	M	M (see Note 1)	See clause 13.1
NOTE 1 – A failed event would not be recorded in this case.				
NOTE 2 – Event types that are optional in this Recommendation are mandatory for the data gathering function only if the particular event type is supported by the VTU.				

11.5.1.10 Event type "Bitswap"

The event type "Bitswap" shall occur when a bitswap command is deferred, rejected or positively acknowledged (i.e., successful), (see clause 13.1) and when no response to a sent bit swapping command is received within the specified time period (i.e., failed) (see Table 11-1). The related event data as per Table 11-51 shall identify the result of the bit swapping procedure.

If a particular bitswap event data occurs at least once, then the bit corresponding to the Bitswap event data in Table 11-51 shall be set to "1". If a particular bitswap event data did not occur, then the bit corresponding to the Bitswap event data in Table 11-51 shall be set to "0". The two highest MSB of the ID shall indicate the number of occurrences of this event during this second, i.e., one event, two events, and more than two events. Multiple instances of this event that occur in the same second shall be recorded simultaneously in a single record using the first two bits of the event data ID to record the total number of Bitswap events. Table 11-51 lists the event data, and the identifier that shall be used in the record to identify the event data. Table 11-51 also indicates whether the event data shall be supported by the VTU-O and/or VTU-R (M indicates "mandatory support").

Table 11-51 – Event data for event type "Bitswap"

Event data	Two MSB of ID	VTU-O	VTU-R	Definition
Number of Bitswap events	0 1	M	M	1 = Number of Bitswap events
	1 0	M	M	2 = Number of Bitswap events
	1 1	M	M	3 = More than two Bitswap events
	Six LSB of ID	VTU-O	VTU-R	Definition
Event data				
Successful bitswap downstream	x x x x x 1	M	M	See clause 13.1
Failed, deferred or rejected bitswap downstream	x x x x 1 x	M (see Note)	M	See clause 13.1
Successful bitswap upstream	x x x 1 x x	M	M	See clause 13.1
Failed, deferred or rejected bitswap upstream	x x 1 x x x	M	M (see Note)	See clause 13.1
NOTE – A failed bitswap would not be recorded in this case.				

11.5.1.11 Event type "Downstream Net Data Rate after Successful SRA"

The event type "Downstream Net Data Rate after Successful SRA" shall occur when a downstream SRA request is positively acknowledged (i.e., successful). The related event data shall identify the downstream net data rate applicable at the completion of the SRA procedure.

The Downstream Net Data Rate after Successful SRA shall be recorded in the event data in the same way as the Downstream Init Net Data Rate (see clause 11.5.1.5).

11.5.1.12 Event type "Upstream Net Data Rate after Successful SRA"

The Event Type "Upstream Net Data Rate after Successful SRA" shall occur when an upstream SRA request is positively acknowledged (i.e., successful). The related event data shall identify the upstream net data rate applicable at the completion of the SRA procedure.

The Upstream Net Data Rate after Successful SRA shall be recorded in the event data in the same way as the Downstream Init Net Data Rate (see clause 11.5.1.5).

11.5.1.13 Event type "Downstream Net Data Rate after Successful SOS"

The event type "Downstream Net Data Rate after Successful SOS" shall occur when a downstream SOS request is positively acknowledged (i.e., successful). The related event data shall identify the downstream net data rate applicable at the completion of the SOS procedure.

The Downstream Net Data Rate after Successful SOS shall be recorded in the Event Data in the same way as the Downstream Init Net Data Rate (see clause 11.5.1.5).

11.5.1.14 Event type "Upstream Net Data Rate after Successful SOS"

The event type "Upstream Net Data Rate after Successful SOS" shall occur when an upstream SOS request is positively acknowledged. The related event data shall identify the upstream net data rate applicable at the completion of the SOS procedure.

The Upstream Net Data Rate after Successful SOS shall be recorded in the Event Data in the same way as the Downstream Init Net Data Rate (see clause 11.5.1.5).

11.5.1.15 Event type "Defect"

If a *los*, *lom*, or *sef* defect (see clauses 11.3.1.3 and 11.3.1.4) occurs during any part of a second, then that second is considered to be a *los* defected second, a *lom* defected second, or a *sef* defected second, respectively. The event type "Defect" shall occur each second when any type of defected second starts or ended. A type of defected second shall be recorded as "starts" when that type of defected second occurs in the current second but did not occur in the previous second. A type of defected second shall be recorded as having "ended" when that type of defected second occurred in the previous second but does not occur in the current second. A particular type of defected second (*los* defected second, *lom* defected second, or *sef* defected second) cannot both start and stop in the same second. In order to gather multiple types of defected second events in one record, the event data shall consist of a bitmap identifying the start and end each of each type of defected second.

Table 11-52 lists the event data and the identifier that shall be used in the event record to identify the event data. Table 11-52 also indicates whether the event data shall be supported by the VTU-O and/or VTU-R (M indicates "mandatory support" and "NA" indicates "not applicable").

Table 11-52 – Event data for event type "Defect"

Event data	ID	VTU-O	VTU-R	Definition
<i>los</i> second starts	x x x x x 0 1	M	M	See clause 11.3.1.3
<i>los</i> second ended	x x x x x 1 0	M	M	See clause 11.3.1.3
<i>lom</i> second starts	x x x x 0 1 x x	M	M	See clause 11.3.1.3
<i>lom</i> second ended	x x x x 1 0 x x	M	M	See clause 11.3.1.3
<i>sef</i> second starts	x x 0 1 x x x x	M	M	See clause 11.3.1.3
<i>sef</i> second ended	x x 1 0 x x x x	M	M	See clause 11.3.1.3

11.5.1.16 Event type "Retransmission Event"

The event type "Retransmission Event" shall occur when the VTU operates in ITU-T G.998.4 (retransmission) mode and one of the retransmission events (see Table 11-53) occurs. The related event data shall identify the retransmission event that occurred.

Table 11-53 lists the event data, and the identifier that shall be used in the record to identify the event data. Table 11-53 also indicates whether the event data shall be supported by the VTU-O and/or VTU-R (M indicates "mandatory support").

Table 11-53 – Event data for event type "Retransmission Event"

Event data	ID	VTU-O	VTU-R	Definition
Reserved for future use	00 ₁₆			
<i>lefr</i> defect	01 ₁₆	M	M	See clause 11.3.3 of [ITU-T G.998.4]
Reserved for use by ITU-T	02 ₁₆ to FF ₁₆			

NOTE – The *lefr* defect is recorded only for upstream at the VTU-O, and it is reported only for downstream at the VTU-R. This is because the *lefr* defect is near-end only.

11.5.2 Buffer management rules

In order to obtain a fair mixing of event types in the buffer, while guaranteeing that the oldest entries per event type are removed first, the following buffer management rules shall apply:

- The sum of the configured logging depths, *logging_depth_event_i*, over all event types shall be smaller than or equal to the number of storable records in the buffer, *logging_depth*.
- When the buffer is not yet full, a new entry can be added without constraints.
- When the buffer is full, before adding a new entry, one entry shall be removed. The entry that shall be removed is the oldest entry out of all event types which are already above their configured logging depths or which would get above their configured logging depths if the new entry was to be added without a removal.

NOTE – The third rule is described as a "remove before add". It can also be rephrased as "remove after add" as follows: "when the buffer is full, the new entry is added to a spare location. The entry that shall be removed is the oldest entry out of all event types which are above their configured logging depths."

These buffer management rules are illustrated in Figure 11-6.

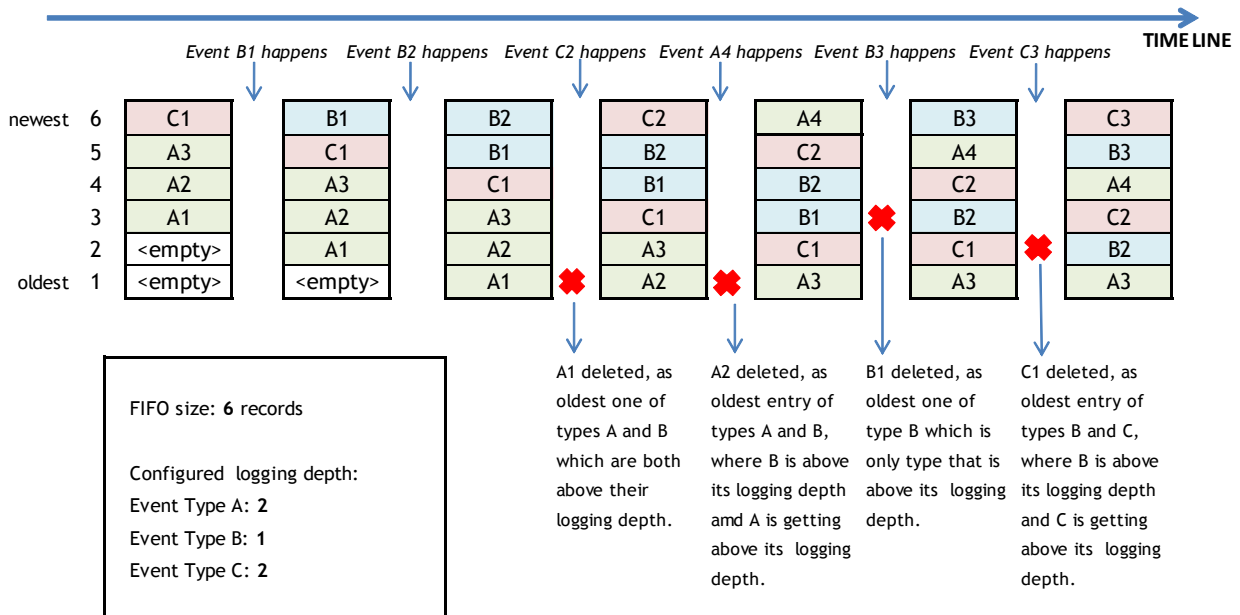

Figure 11-6 – Illustration of the buffer management rules

12 Link activation methods and procedures

12.1 Overview

12.1.1 Link states and link state diagram

The VDSL2 link states and activation/deactivation procedures diagram is illustrated in Figure 12-1.

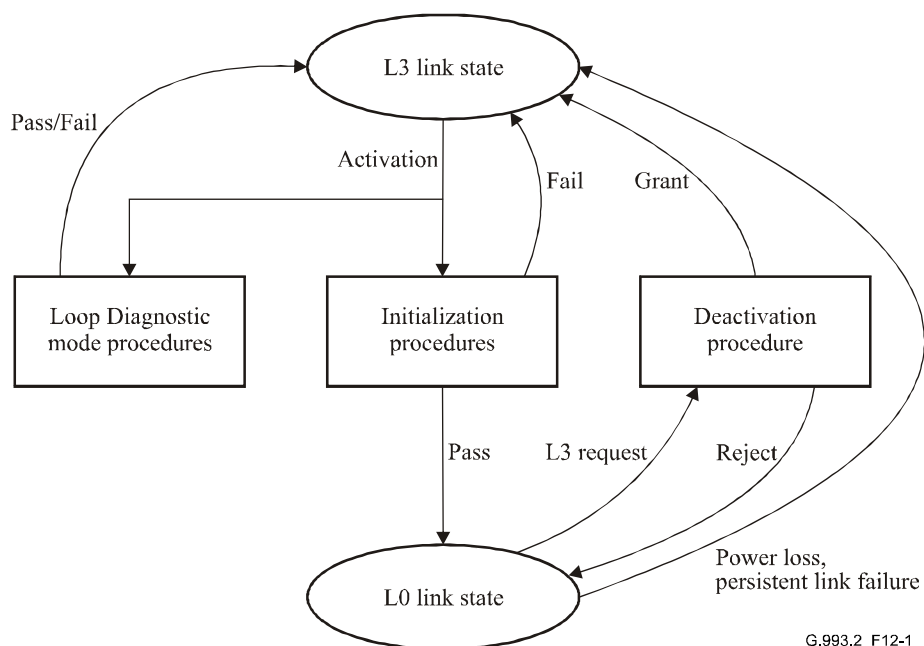

Figure 12-1 – VDSL2 link states and link state diagram

Figure 12-1 has two link states (L0 and L3), and also contains the procedures that allow the link to change from one link state to another. The link states are shown in rounded boxes, whilst the procedures are shown as rectangular boxes.

L3 is the link state where the VTU is provisioned through a management interface for the service desired by the operator. In this link state, both the VTU-O and VTU-R do not transmit any signal.

L0 is the link state achieved after the initialization procedure has completed successfully by both VTUs. In this link state, the link shall transport user information with standard performance characteristics according to the CO-MIB configuration.

12.1.2 Transceiver states and transceiver state diagram

State diagrams are given in Figure 12-2 for the VTU-O, and in Figure 12-3 for the VTU-R. States are indicated by ovals, with the name of the state given within the oval. The states are defined in Table 12-1 for the VTU-O and in Table 12-2 for the VTU-R. Transitions between states are indicated by arrows, with the event causing the transition listed next to the arrow. All states are mandatory.

A variety of "host controller" commands (events preceded by "c:_" and "r:_") are shown as non-mandatory in either state diagram to provide example events and transitions between states. The way in which these events are implemented is left to the vendor since many options are possible.

In the state diagram for the VTU-O, a C-IDLE state would be desired to guarantee a quiet mode, which may be useful to allow certain tests (e.g., MLT), or to discontinue service.

In the state diagram for the VTU-R, a self-test function is desirable, but it may be a vendor/customer option to define when self-test occurs (e.g., always at power-up or only under VTU-O control), and which transition to take after successfully completing self-test (e.g., enter R-IDLE, or enter R-SILENT).

IDLE is the state where the VTU is provisioned through a management interface for the service desired by the operator. In this state, the VTU does not transmit any signal. A VTU that receives a higher layer signal to activate (c:_L0_request for VTU-O or r:_L0_request for VTU-R) shall use the initialization procedure defined in clause 12.3 to transition the link from the L3 to the L0 state. A VTU that detects the signals of the initialization procedure at the U reference point, if enabled, shall respond by using the initialization procedure. If disabled, the VTU shall remain in the IDLE state.

The link transitions to the L0 state once the initialization procedure has completed successfully and both VTUs are in the SHOWTIME state. A VTU-O shall return to the O-SILENT state upon a guided power management (c:_L3_request, see clause 11.2.3.9), or upon a re-initialization triggered by Re-Initialization Policy (see clause 12.1.4). A VTU-R shall return to the R-SILENT state upon a guided power management (r:_L3_request, see clause 11.2.3.9), or upon a re-initialization triggered by Re-Initialization Policy (see clause 12.1.4). With the former, a VTU-R shall set AUTO_init=OFF to disable autonomous proceeding to the R-INIT/HS state. With the latter, a VTU-R shall set AUTO_init=ON to enable autonomous proceeding to the R-INIT/HS state.

The receiving VTU shall transition state upon Persistent LOS and/or LOF failure (see clause 12.1.4). This implies that if no high_BER-hs or high_BER-fs events cause the receiving VTU to transition state earlier, then the persistency allows the transmitting VTU to detect the LOS or LOF failure condition through the indicator bits, before the receiving VTU transitions state (i.e., removes the Showtime signal from the line).

NOTE – High_BER-fs event relates to fast start-up, which is for further study (see clause 12.5).

The receiving VTU shall also transition state upon a high_BER event (see clause 12.1.4). This event relates to near-end and/or far-end performance primitives and performance counters for which thresholds may be configured through the CO-MIB as to declare a high_BER event upon threshold crossing.

If the VTU-O transitions from O-SHOWTIME to O-SILENT, then the VTU-R shall detect a Persistent LOS Failure, shall transition to R-SILENT followed by R-INIT/HS and shall transmit R-TONES-REQ within a maximum of 6 s after the VTU-O transitioning to O-SILENT.

If the VTU-R transitions from R-SHOWTIME to R-SILENT, then the VTU-O shall detect a Persistent LOS Failure, shall transition to O-SILENT, either followed by waiting to receive R-TONES-REQ (VTU-R initiated HS) or followed by O-INIT/HS (VTU-O initiated HS).

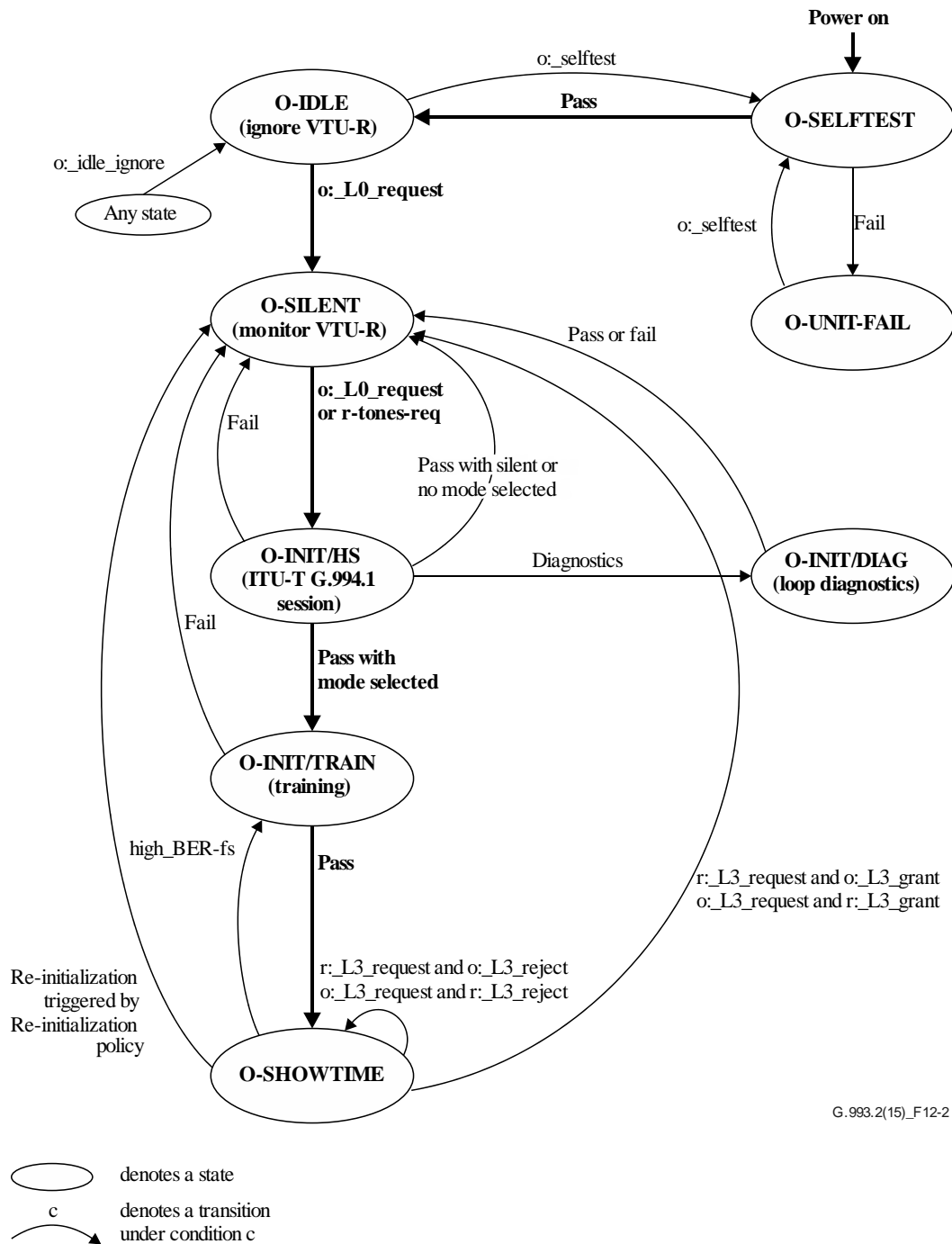

G.993.2(15)_F12-2

Figure 12-2 – State diagram for the VTU-O

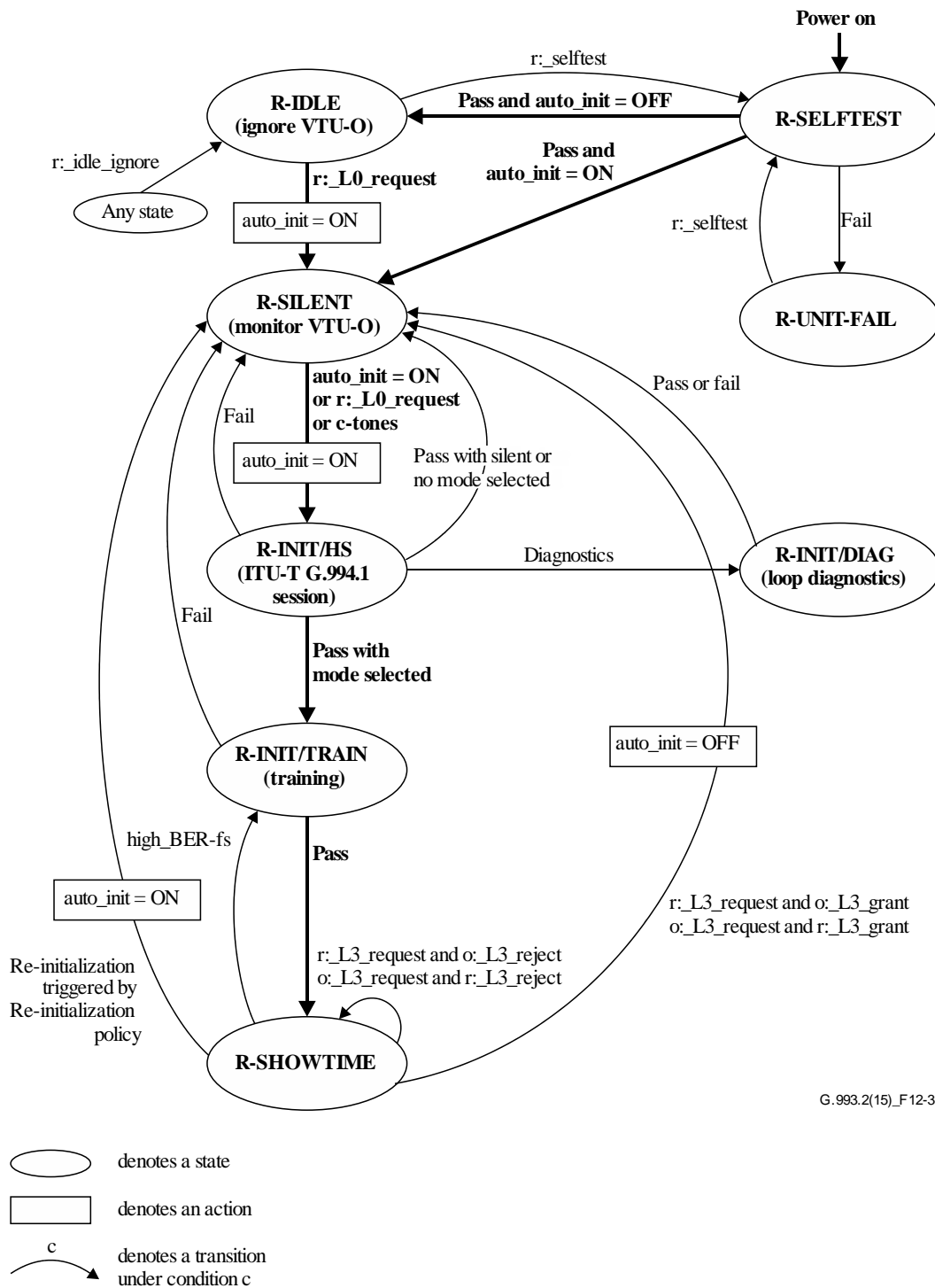

G.993.2(15)_F12-3

Figure 12-3 – State diagram for the VTU-R

Table 12-1 – VTU-O state definitions

State name	Description
O-SELFTEST (mandatory)	<ul style="list-style-type: none"> • Temporary state entered after power-up in which the VTU performs a self-test; • Transmitter off (QUIET at U-O interface); • Receiver off (no response to R-TONES-REQ signal); • No response to host control channel; • If self-test pass then transition to O-IDLE; • If self-test fail then transition to O-UNIT-FAIL.
O-UNIT-FAIL (mandatory)	<ul style="list-style-type: none"> • Steady state entered after an unsuccessful VTU self-test; • Transmitter off (QUIET at U-O interface); • Receiver off (no response to R-TONES-REQ signal); • Monitor host control channel if possible (allows the host controller to retrieve self-test results).
O-IDLE (mandatory)	<ul style="list-style-type: none"> • Steady state entered after successful self-test; • Transmitter off (QUIET at U-O interface); • Receiver off (no response to R-TONES-REQ signal); • Monitor host control channel.
O-SILENT (mandatory)	<ul style="list-style-type: none"> • Steady state defined in ITU-T G.994.1, entered upon host controller command; • Transmitter off (QUIET at U-O interface); • Receiver on (monitor for R-TONES-REQ signal, if detected, transition to O-INIT/HS state); • Monitor host control channel.
O-INIT/HS (mandatory)	<ul style="list-style-type: none"> • Temporary state entered to perform ITU-T G.994.1 phase of initialization; • Transmitter on (start with transmitting C-TONES signal); • Receiver on (start with monitoring for R-SILENT0 signal); • Monitor host control channel; • If silent period or no mode selected then transition to O-SILENT1; • If loop diagnostics mode then transition to O-INIT/DIAG; • If operating mode selected then transition to O-INIT/TRAIN.
O-INIT/TRAIN (mandatory)	<ul style="list-style-type: none"> • Temporary state entered to perform other phases of initialization; • Transmitter on (start with O-P-QUIET1); • Receiver on (start with monitoring for R-P-QUIET1); • If init pass then transition to O-SHOWTIME; • If init fail then transition to O-SILENT; • Monitor host control channel.
O-INIT/DIAG (mandatory)	<ul style="list-style-type: none"> • Temporary state entered to perform other phases of initialization in loop diagnostics mode; • Transmitter on (start with O-P-QUIET1); • Receiver on (start with monitoring for R-P-QUIET1); • Transition to O-SILENT; • Monitor host control channel.

Table 12-1 – VTU-O state definitions

State name	Description
O-SHOWTIME (mandatory)	<ul style="list-style-type: none"> • Steady state entered to perform bit pump functions (frame bearers active); • On-line reconfigurations occur within this state; • Upon conditions satisfying the Re-Initialization Policy (<i>Rlpolicy_n</i>) then transition to O-SILENT; • If link transition to L3 state is granted, then transition to O-SILENT; • Monitor host control channel.

Table 12-2 – VTU-R state definitions

State name	Description
R-SELFTEST (mandatory)	<ul style="list-style-type: none"> • Temporary state entered after power-up in which the VTU performs a self-test; • Transmitter off (QUIET at U-R interface); • Receiver off (no response to C-TONES signal); • No response to host control channel; • If self-test pass then transition to R-IDLE if VTU is under host control or transition to R-SILENT if VTU is in automatic training mode; • If self-test fail then transition to R-UNIT-FAIL.
R-UNIT-FAIL (mandatory)	<ul style="list-style-type: none"> • Steady state entered after an unsuccessful VTU self-test; • Transmitter off (QUIET at U-R interface); • Receiver off (no response to C-TONES signal); • Monitor host control channel if possible (allows the host controller to retrieve self-test results).
R-IDLE (mandatory)	<ul style="list-style-type: none"> • Steady state entered after successful self-test if VTU is under host control; • Transmitter off (QUIET at U-R interface); • Receiver off (no response to C-TONES signal); • Monitor host control channel.
R-SILENT (mandatory)	<ul style="list-style-type: none"> • Temporary state defined in[ITU-T G.994.1] entered after self-test pass if VTU is in automatic training mode or with host controller command; • Transmitter off (transmit R-SILENT0 signal); • Receiver on (monitor for C-TONES signal, if detected, transition to R-INIT/HS state); • Automatic training: immediate transition to R-INIT/HS (unless delayed for silent period or in orderly shutdown condition); • Monitor host control channel.
R-INIT/HS (mandatory)	<ul style="list-style-type: none"> • Temporary state entered to perform ITU-T G.994.1 phase of initialization; • Transmitter on (start with transmitting R-TONES-REQ signal); • Receiver on (start with monitoring for C-TONES signal); • Monitor host control channel; • If silent period or no mode selected then transition to R-SILENT; • If loop diagnostics mode then transition to R-INIT/DIAG; • If operating mode selected then transition to R-INIT/TRAIN.

Table 12-2 – VTU-R state definitions

State name	Description
R-INIT/TRAIN (mandatory)	<ul style="list-style-type: none"> • Temporary state entered to perform other phases of initialization; • Transmitter on (start with R-P-QUIET1 signal); • Receiver on (start with monitoring for C-P-QUIET1 signal); • If init pass then transition to R-SHOWTIME; • If init fail then transition to R-SILENT; • Monitor host control channel.
R-INIT/DIAG (mandatory)	<ul style="list-style-type: none"> • Temporary state entered to perform other phases of initialization in loop diagnostics mode; • Transmitter on (start with R-P-QUIET1); • Receiver on (start with monitoring for C-P-QUIET1); • Transition to R-SILENT; • Monitor host control channel.
R-SHOWTIME (mandatory)	<ul style="list-style-type: none"> • Steady state entered to perform bit pump functions (frame bearers active); • On-line reconfigurations occur within this state; • Upon conditions satisfying the Re-Initialization Policy (<i>RIpolicy_n</i>) then transition to R-SILENT; • If link transition to L3 state is granted, then transition to R-SILENT; • Monitor host control channel.

12.1.3 Initialization procedures

During the ITU-T G.994.1 handshake phase of the initialization procedure, the VTUs exchange capability lists and agree on a common mode for training and operation using the ITU-T G.994.1 protocol. A successful completion of the ITU-T G.994.1 handshake phase will lead to either the channel discovery phase of initialization or the loop diagnostic mode (depending on which one is selected). Failure of the ITU-T G.994.1 handshake phase leads the VTU back to the SILENT state and leads the link back to the L3 state. The handshake procedure is described in clause 12.3.2 and [ITU-T G.994.1].

During the channel discovery, training, and channel analysis and exchange phases of initialization, the VTUs train their respective transceivers after identifying the common mode of operation. During these phases, the transceivers identify channel conditions, exchange parameters for Showtime operation, etc. After successful completion of the initialization procedure, the transceivers transition to the SHOWTIME state (Showtime). Upon unsuccessful completion of the initialization procedure, the VTUs return to the SILENT state and the link returns to the L3 state. The initialization phases are described in clauses 12.3.3 through 12.3.5.

12.1.4 Deactivation, power loss, persistent link failure and high_BER events

The deactivation procedure allows an orderly shutdown of the link. The VTUs shall follow the procedures described in clause 11.2.3.9 to transition the link from the L0 state to the L3 state.

The link is in the L3 state, after both VTU-O and VTU-R have transitioned from the SHOWTIME state to the SILENT state.

Two policies are defined for the VTU to trigger a transition from the SHOWTIME state to the SILENT state. The selection of the policy is controlled via the parameter "Re-initialization Policy" (*RIpolicy_n*).

In the first policy ($Rpolicy_n=0$) (mandatory), a VTU shall transition from the SHOWTIME state to the SILENT state in the case of

1. loss of receive power (power loss); or
2. persistent link failure; or
3. upon a high_BER-hs event as defined below for $Rpolicy_n=0$.

The VTU shall declare a power loss when a persistent LOS failure is declared. Persistent LOS failure is declared after 2.5 ± 0.5 s of near-end LOS failure with the *los* (see clause 11.3.1.3) still present. An LOS failure is declared after 2.5 ± 0.5 s of contiguous *los*, or, if *los* is present when the criteria for LOF failure declaration have been met (see LOF Failure definition below). An LOS failure is cleared after 10 ± 0.5 s of no *los*.

The VTU shall declare a persistent link failure when a persistent LOF failure is declared. A persistent LOF failure is declared after 2.5 ± 0.5 s of near-end LOF failure with the *sef* (see clause 11.3.1.3) still present. An LOF failure is declared after 2.5 ± 0.5 s of contiguous near-end *sef*, except when an *los* or LOS failure is present (see LOS failure definition above). An LOF failure is cleared when LOS failure is declared, or after 10 ± 0.5 s of no *sef*.

The high_BER-hs event in $Rpolicy_n=0$ shall be declared whenever any of the parameters listed in Table 12-3 exceeds the listed threshold. Other conditions are vendor-specific and are (but are not required to be) related to near-end and/or far-end performance primitives. As an example, the VTU may also declare a high_BER event after 30 s of persistent near-end or far-end *lom* defect. The VTU should trade-off the persistency in the high_BER events to, on the one hand, quickly recover data integrity, but on the other hand, not to unnecessarily interrupt data transmission. This trade-off may be enhanced if the VTU is able to detect and quantify instantaneous changes in line conditions.

Table 12-3 – Conditions for declaring a high_BER-hs event in $Rpolicy_n=0$

Parameter	Threshold
Number of successful SOS procedures performed within a 120-second interval	MAX-SOS threshold configured in CO-MIB
Number of seconds the actual net data rate (<i>net_act_n</i>) is below the minimum net data rate (<i>net_min_n</i>) for any bearer channel after a successful SOS procedure	20 seconds
Duration of time interval with consecutive eoc message time-outs without a single successful eoc command/response exchange	Vendor discretionary
NOTE – Other conditions declaring a high_BER event are vendor specific.	

In determining the number of successful SOS procedures performed within a 120-second interval, the 120-second measurement interval shall be started at the first successful SOS procedure after getting into Showtime and re-started at the first successful SOS procedure occurring after a previous 120-second period interval has expired with the number of successful SOS procedures being less than MAX-SOS. The 120 second measurement intervals shall be sequential periods, not a sliding window.

The SOS procedure shall be considered as successful when the VTU initiating the SOS receives the SyncFlag in response (regardless whether the SyncFlag was received after a single or multiple SOS requests).

In the second policy ($Rpolicy_n=1$) (optional), a VTU shall transition from the SHOWTIME state to the SILENT state in the case of

1. loss of receive power (power loss); or
2. persistent link failure; or

3. persistent near-end loss of margin failure; or
4. persistent TPS-TC out-of-sync failure; or
5. upon a high_BER-hs event as defined below for $Rlpolicy_n=1$.

The VTU shall declare a power loss identical to Re-Initialization Policy 0.

The VTU shall declare a persistent link failure identical to Re-Initialization Policy 0.

The VTU shall declare a persistent loss of margin failure after 60 ± 1 s of contiguous near-end loss of margin defect (*lom*).

The VTU shall declare a persistent TPS-TC out-of-sync failure after 15 ± 1 s of contiguous near-end TPS-TC out-of-sync condition.

In the case that the TPS-TC is ATM, the TPS-TC out-of-sync condition corresponds with near-end loss of cell delineation defect (*lcd-n*). (See clause L.2).

In the case that the TPS-TC is PTM, the TPS-TC out-of-sync condition corresponds with near-end TC_out_of_sync (*oos-n*) anomaly. (See clause N.4 of [ITU-T G.992.3]).

The high_BER-hs event in $Rlpolicy_n=1$ shall be declared whenever any of the parameters listed in Table 12-4 exceeds the listed threshold.

Table 12-4 –Conditions for declaring a high_BER-hs event in $Rlpolicy_n=1$

Parameter	Threshold
Number of contiguous near-end SES	REINIT_TIME_THRESHOLD configured in CO-MIB
Number of successful SOS procedures performed within a 120-second interval	MAX-SOS threshold configured in CO-MIB
Number of seconds the actual net data rate (<i>net_act_n</i>) is below the minimum net data rate (<i>net_min_n</i>) for any bearer channel after a successful SOS procedure	20 seconds
Duration of time interval with consecutive eoc message time-outs without a single successful eoc command/response exchange	REINIT_TIME_THRESHOLD configured in CO-MIB
NOTE – At the VTU-R, no other conditions shall declare a high_BER-hs event. At the VTU-O, no other near-end conditions shall declare a high_BER-hs event. Declaration of a high_BER-hs event based on far-end conditions are vendor specific.	

12.1.5 Loop diagnostic procedure

Loop diagnostic mode is intended to identify channel conditions at both ends of the loop without transitioning to the SHOWTIME state. The VTUs will return to the SILENT state after completion of the loop diagnostic mode. Loop diagnostic mode is described in clause 12.4.

12.2 Special operations channel (SOC)

The SOC provides a bidirectional communication of messages between the VTU-O and the VTU-R to support initialization, fast start-up, and loop diagnostic procedures.

The SOC has 2 states; active and inactive. Its state is determined by the stages of initialization, and is indicated in the timing diagrams in Figures 12-6, 12-9 and 12-11 and described in the signal and message summary tables in clauses 12.3.3, 12.3.4, and 12.3.5.

12.2.1 Message format

The SOC shall use an HDLC-like format with byte stuffing (octet transparency) and a frame check sequence (FCS) to monitor errors as specified in [ITU-T G.997.1].

The structure of an HDLC frame shall be as illustrated in Figure 12-4.

Size in octets	Meaning	Value
1	Flag	7E ₁₆
1	Address field	Message index
1	Control field	Segmentation index
Up to 1024	Information payload	Payload bytes
1	Frame check sequence	FCS
1	Frame check sequence	FCS
1	Flag	7E ₁₆

Figure 12-4 – Structure of HDLC frames used in the SOC protocol

The message index is dependent on the acknowledgment mode (i.e., AR or RQ) and whether a message is being repeated. It is defined in clause 12.2.2.

The segmentation index facilitates the message segmentation as described in clause 12.2.6. If no segmentation is used, the segmentation index shall be set to 11₁₆. The number of SOC bytes (before byte stuffing) transmitted in a single HDLC frame shall not exceed 1024.

12.2.2 Communication protocol

The SOC shall use either an automatic repeat (AR) mode or a repeat request (RQ) mode.

12.2.2.1 Automatic repeat (AR) mode

In AR mode, messages encapsulated in HDLC frames shall be automatically repeated. At least four idle flags (7E₁₆) shall be inserted between successive frames.

The message index shall always be set to 01₁₆ in AR mode. The segmentation index shall be set to 11₁₆ if the message is not segmented, and as specified in clause 12.2.6 if the message is segmented.

Table 12-5 shows the structure of each HDLC frame in AR mode.

Table 12-5 – HDLC frames in AR mode

Field	Content
Flag	7E ₁₆
Message index	01 ₁₆
Segmentation index	11 ₁₆ if not segmented; as in clause 12.2.6 if segmented
Information payload	Variable, up to 1024 bytes
FCS	Variable
FCS	Variable
Flag	7E ₁₆

The sending of a message in AR mode shall be terminated by receipt of an acknowledgment of the message. The acknowledgment may be sent at any time.

12.2.2.2 Repeat request (RQ) mode

In RQ mode, each message encapsulated in an HDLC frame shall be sent only once. However, the VTU expecting the message shall have the opportunity to request the remote side to repeat the message by sending an O/R-REPEAT_REQUEST message when the expected message has a wrong FCS or when a time-out has expired. After two unsuccessful O/R-REPEAT_REQUEST attempts, the activation shall be aborted (i.e., considered an unsuccessful activation). The value of the time-out shall be 2 s. The VTU shall start the time-out counter as it transmits the last byte of the message (segment) and stop the counter as it receives the Control field of the expected incoming message (segment). For the first message (segment) following activation/re-activation of the SOC, the VTU shall count the time-out from this activation time to the reception of the Control field of the message (segment) in accordance with the specific message exchange protocol defined in clauses 12.3.3, 12.3.4, and 12.3.5.

In RQ mode, a VTU shall never send a message (segment) prior to receiving an acknowledgement of the previously sent message (segment). This acknowledgement could be either a message in accordance with the message exchange protocol of the specific initialization phase, or a special signal (O-P-SYNCHRO or R-P-SYNCHRO), as described in clauses 12.3.3, 12.3.4, and 12.3.5. Once acknowledged, messages (segments) shall not be re-sent.

Upon entering the RQ mode, the message index shall initially be set to 01_{16} and shall be incremented by 1 as the acknowledgement of a message is received. The index shall wrap around in case of overflow. The value 00_{16} has a special meaning, as described below, and shall be skipped. This means that index value FF_{16} shall be followed by 01_{16} . The index shall not be incremented if an O/R-REPEAT_REQUEST message is received. The segmentation index shall be set to 11_{16} if the message is not segmented, and as specified in clause 12.2.6 if the message is segmented. The message index and segmentation index of the message (segment) shall not be changed if the message (segment) is re-sent.

The message index and segmentation index of the O/R-REPEAT_REQUEST message shall be set to 00_{16} . These fields shall be ignored by the receiver (because there can be only one unacknowledged message or segment at a time).

12.2.3 Mapping of SOC data

An SOC message shall contain an integer number of octets. All octets shall be sent LSB first. An SOC message may be subdivided into fields. A field can contain parameter values expressed in more than one byte. In this case, the field shall be split into bytes with the byte containing the MSBs of the parameter value sent first. For example, a field carrying a 16-bit value m_{15}, \dots, m_0 shall be split into a first byte $B_0 = m_{15} \dots m_8$ and a second byte $B_1 = m_7 \dots m_0$. The description of fields for specific messages is given in detail in clauses 12.3.3, 12.3.4, and 12.3.5. All fields that follow the fields defined for a specific message shall be ignored.

NOTE – If future versions of this Recommendation add extra fields to the ones already defined, for reasons of backward compatibility, these fields must be appended to the currently defined ones.

Some SOC messages may contain several fields. Some fields can be merged together to form a logical entity called a macro-field, such as "PSD descriptor" and "Bands descriptor", which are described in clause 12.3.3.2.1.1.

12.2.4 SOC idle (O-IDLE, R-IDLE)

When the VTU-O's SOC is in the active state but idle (i.e., it has no message to send), it shall send O-IDLE. Similarly, the VTU-R shall send R-IDLE when its SOC is in the active state but idle.

O-IDLE and R-IDLE shall consist of HDLC flags: 7E₁₆. This octet shall be sent repeatedly instead of HDLC frames.

12.2.5 SOC messages

12.2.5.1 Message codes

The information payload of every SOC message shall start with a one byte field containing a unique code to identify the type of message. For one-byte messages the message code is the entire content of the message. The message codes for all defined messages are shown in Table 12-6.

NOTE – Other than O/R-REPEAT_REQUEST and O/R-ACK-SEG, which have special message codes, messages sent by the VTU-O have the MSB equal to ZERO, whilst messages sent by the VTU-R have the MSB equal to ONE.

Table 12-6 – Message codes for the SOC messages

SOC message	Message code	Notes
O/R-REPEAT_REQUEST	55 ₁₆	(Note)
O/R-ACK-SEG	0F ₁₆	(Note)
VTU-O messages		
O-ACK	00 ₁₆	(Note)
O-SIGNATURE	01 ₁₆	see clause 12.3.3.2.1.1
O-UPDATE	02 ₁₆	see clause 12.3.3.2.1.2
O-MSG 1	03 ₁₆	see clause 12.3.5.2.1.1
O-PRM	04 ₁₆	see clause 12.3.3.2.1.3
O-TA_UPDATE	05 ₁₆	see clause 12.3.4.2.1.1
O-TPS	06 ₁₆	see clause 12.3.5.2.1.2
O-PMS	07 ₁₆	see clause 12.3.5.2.1.3
O-PMD	08 ₁₆	see clause 12.3.5.2.1.4
O-PRM-LD	09 ₁₆	see clause 12.4.2.1.1
O-MSG-LD	0A ₁₆	see clause 12.4.3.1.1
VTU-R messages		
R-ACK	80 ₁₆	(Note)
R-MSG 1	81 ₁₆	see clause 12.3.3.2.2.1
R-UPDATE	82 ₁₆	see clause 12.3.3.2.2.2
R-MSG 2	83 ₁₆	see clause 12.3.5.2.2.1
R-PRM	84 ₁₆	see clause 12.3.3.2.2.3
R-TA_UPDATE	85 ₁₆	see clause 12.3.4.2.2.1
R-TPS-ACK	86 ₁₆	see clause 12.3.5.2.2.2
R-PMS	87 ₁₆	see clause 12.3.5.2.2.3

Table 12-6 – Message codes for the SOC messages

SOC message	Message code	Notes
R-PMD	88 ₁₆	see clause 12.3.5.2.2.4
R-PRM-LD	89 ₁₆	see clause 12.4.2.1.2
R-MSG-LD	8A ₁₆	see clause 12.4.3.1.2
NOTE – This is the entire payload of the message.		

12.2.5.2 O/R-REPEAT_REQUEST

This message shall be used in RQ mode to request the remote side to resend the last unacknowledged message (segment), as described in clause 12.2.2.2. The format of the message shall be as specified in clause 12.2.1, and the payload shall be as specified in Table 12-6.

In AR mode, O/R-REPEAT_REQUEST messages shall be ignored.

12.2.5.3 O/R-ACK-SEG

This message shall be used in RQ mode to acknowledge the reception of intermediate segments of a segmented message, as described in clause 12.2.2.2. The format of the message shall be as specified in clause 12.2.1 and the payload shall be as specified in Table 12-6.

In AR mode, and when no segmentation is used, any O/R-ACK-SEG messages shall be ignored.

12.2.5.4 VTU-O and VTU-R messages

These messages are described in detail in clauses 12.3.3, 12.3.4, and 12.3.5.

12.2.6 Segmentation of messages

Messages that are larger than the maximum allowed size (1024 bytes) shall be segmented before transmission; messages shorter than 1024 bytes may also be segmented to improve robustness. To allow segmentation, a segmentation index is included in the control field of the HDLC frame. The four MSBs of this field shall indicate the number of segments, to a maximum of 15, into which the message has been segmented. The four LSBs of this field shall indicate the index of the current segment, starting from 1₁₆. For example, a segmentation index value of 93₁₆ indicates the third segment of a total of nine. In case the message is not segmented, the value of the field shall be 11₁₆.

In RQ mode, an acknowledgement (O/R-ACK-SEG) shall be sent for all but the last segment. Typically, the last segment signals the end of the message and will therefore be acknowledged by the reply to the message. The O/R-ACK-SEG message (see Table 12-6) shall be used to acknowledge the reception of the other segments. The O/R-ACK-SEG message shall have its message index assigned by the generic rule defined in clause 12.2.2.2, and shall be increased by 1 when a new segment is received. The segmentation index of each O/R-ACK-SEG message shall be set to 11₁₆. Once acknowledged, segments shall not be retransmitted and re-transmission shall not be requested.

In AR mode, segmentation shall be done in the same way, but there will be no acknowledgements (O/R-ACK-SEG) between different segments of the same message. Segments shall be sent in sequential order. All segments shall be sent before the message is repeated.

12.3 Initialization procedure

12.3.1 Overview

Initialization of a VTU-O/VTU-R pair includes the following main tasks:

- Definition of a common mode of operation (profile, band plan and initial values of basic modulation parameters);

- Synchronization (sample clock alignment and symbol alignment);
- Transfer from the VTU-O to the VTU-R of transmission parameters, including information on the PSD masks to be used, RFI bands (e.g., amateur radio bands) to be protected, and target data rates in both transmission directions;
- Channel identification;
- Noise identification;
- Calculation of framer, interleaver, and coding parameters, as well as the bit loading and gain tables; and
- Exchange of VTU parameters (including RS settings, interleaver parameters, framer settings, bit loading and gain tables).

The common mode of operation shall be negotiated during the ITU-T G.994.1 handshake phase. Information such as the PSD mask, locations of RFI bands to be notched, and target data rates shall be initially available at the VTU-O through the MIB.

The time line in Figure 12-5 provides an overview of the initialization procedure, which contains four phases. Following the initial ITU-T G.994.1 handshake phase, upstream power back-off is applied and a full duplex link between the VTU-O and the VTU-R is established during the channel discovery phase to set the PSDs of the transmit signals and the main modulation parameters. During the training phase, any time-domain equalizers (TEQs) and echo cancellers may be trained, and the timing advance is refined. During the channel analysis and exchange phase, the two VTUs shall measure the characteristics of the channel and exchange parameters to be used in showtime.

VTU-O	ITU-T G.994.1 handshake (12.3.2)	Channel discovery (12.3.3)	Training (12.3.4)	Channel analysis and exchange (12.3.5)
VTU-R	ITU-T G.994.1 handshake (12.3.2)	Channel discovery (12.3.3)	Training (12.3.4)	Channel analysis and exchange (12.3.5)

G.992.3(15)_F12-5

Figure 12-5 – Overview of initialization procedure

The transition to the next phase of initialization shall occur after all tasks in a phase have been completed. A time-out period is defined for each phase to avoid suspension of the initialization procedure. Violation of the time-out or an inability to complete a task results in abortion of the activation process (unsuccessful activation).

The initialization procedure shall be aborted immediately after any of the following events is discovered:

- Time-out of any phase;
- Missing or incomplete task during any phase;
- Violation of the initialization protocol during any phase (including time-out for acknowledging an SOC message); or
- Detection of 250 ms of unscheduled silence.

In all phases, the time-out counter shall be started as the VTU enters the phase and shall be reset upon completion of the phase. The following values for the time-outs shall be used:

- ITU-T G.994.1 handshake phase: As defined in [ITU-T G.994.1];
- Channel discovery phase: 10 s;

- Training phase: 10 s; and
- Channel analysis and exchange phase: 10 s.

Exchange of information between the VTU-O and VTU-R during all phases of initialization, excluding the ITU-T G.994.1 handshake phase, shall be performed using the messaging protocol over the special operations channel (SOC) defined in clause 12.2.

12.3.2 ITU-T G.994.1 handshake phase

The detailed procedures for the ITU-T G.994.1 handshake phase are defined in [ITU-T G.994.1].

12.3.2.1 Handshake – VTU-O

A VTU-O, after power-up, loss of signal, or recovery from errors during the initialization procedure, shall enter the initial ITU-T G.994.1 state, C-SILENT1. The VTU-O may either activate the link or respond to R-TONES-REQ (VTU-R initiated activation) by transitioning to C-TONES. Operation shall then proceed according to the procedures defined in [ITU-T G.994.1].

If ITU-T G.994.1 procedures select this Recommendation as the mode of operation, the VTU-O shall continue with ITU-T G.993.2 initialization at the conclusion of ITU-T G.994.1 operation.

12.3.2.1.1 CL messages

A VTU-O wishing to indicate ITU-T G.993.2 capabilities in an ITU-T G.994.1 CL message shall do so by setting to ONE the ITU-T G.993.2 SPar(1) bit as defined in Table 11.0.4 of [ITU-T G.994.1]. The NPar(2) (Table 11.67 of [ITU-T G.994.1]) and SPar(2) (Table 11.68 of [ITU-T G.994.1]) fields corresponding to the ITU-T G.993.2 SPar(1) bit are defined in Tables 12-7 and 12-8, respectively. For each ITU-T G.993.2 SPar(2) bit set to ONE, a corresponding NPar(3) field shall also be present (beginning with Table 11.68.1 in clause 9.4 of [ITU-T G.994.1]). Table 12-9 shows the definitions and coding for the VTU-O CL NPar(3) fields.

Table 12-7 – VTU-O CL message NPar(2) bit definitions

ITU-T G.994.1 NPar(2) Bit	Definition of NPar(2) bit
All-digital mode	If set to ONE, signifies that the VTU-O supports all-digital mode.
Support of downstream virtual noise	If set to ONE, signifies that the VTU-O supports the use of the downstream virtual noise mechanism.
Lineprobe	Always set to ONE in a VTU-O CL message.
Loop Diagnostic mode	Set to ONE if the VTU-O requests loop diagnostic mode.
Support of PSD shaping in US0	Always set to ONE in a VTU-O CL message.
Support of equalized FEXT UPBO	If set to ONE, signifies that the VTU-O supports equalized FEXT UPBO.
ITU-T G.993.5-friendly ITU-T G.993.2 operation in the downstream direction	See Annex X, Table X.1.
Full ITU-T G.993.5-friendly ITU-T G.993.2 operation	See Annex Y, Table Y.1.

Table 12-7 – VTU-O CL message NPar(2) bit definitions

ITU-T G.994.1 NPar(2) Bit	Definition of NPar(2) bit
Alternative electrical length estimation method	If set to ONE, signifies that the VTU-O supports the Alternative Electrical Length Estimation Method (ELE-M1)
Support of downstream SAVN	If set to ONE, signifies that the VTU-O supports the use of the downstream SAVN mechanism.

Table 12-8 – VTU-O CL message SPar(2) bit definitions

ITU-T G.994.1 SPar(2) Bit	Definition of Spar(2) bit
Profiles	Always set to ONE.
Bands Upstream	Always set to ONE.
Bands Downstream	Always set to ONE.
RFI Bands	If set to ONE, indicates that RFI band transmit PSD reductions are enabled. If set to ZERO, indicates that RFI band transmit PSD reductions are disabled (Note 1).
Initial IDFT Size ($2N$)	Always set to ONE.
CE Lengths	If set to ZERO, indicates that the VTU-O can support only the mandatory CE length of $5N/32$ for the IDFT size equal to $2N$. If set to ONE, indicates that the VTU-O supports optional CE lengths in addition to the mandatory one.
Annex A US0 (Note 2)	If set to ONE, indicates that the corresponding NPar(3) shall indicate which of the US0 PSD masks described in Annex A are supported by the VTU-O.
Annex B US0 (Note 2)	If set to ONE, indicates that the corresponding NPar(3) shall indicate which of the US0 PSD masks described in Annex B are supported by the VTU-O.
Annex C US0 (Note 2)	If set to ONE, indicates that the corresponding NPar(3) shall indicate which of the US0 PSD masks described in Annex C are supported by the VTU-O.
NOTE 1 – The RFI Bands shall apply to both directions of transmission.	
NOTE 2 – At least one of these bits shall be set to ONE.	

Table 12-9 – VTU-O CL message NPar(3) bit definitions

ITU-T G.994.1 SPar(2) Bit	Definition of NPar(3) bits
Profiles	Each valid profile is represented by one bit in a field of 8 bits. The valid profiles are: 8a, 8b, 8c, 8d, 12a, 12b, 17a and 30a. Each profile supported by the VTU-O is indicated by setting its corresponding bit to ONE.
Bands Upstream	For a given band plan as defined in the regional annexes, this NPar(3) field shall include all of the upstream bands in ascending order starting at f_2 (as shown in Figure A.1, Table B.1, Figure C.1) and ending at the highest band required for the highest frequency profile for which support is indicated. Up to four upstream bands may be defined. Each band shall be defined by a start subcarrier index and stop subcarrier index using 13 bits per index value. The subcarrier indices shall represent 4.3125 kHz subcarrier spacing. Adjacent upstream bands shall be coded as separate bands.
Bands Downstream	For a given band plan as defined in the regional annexes, this NPar(3) field shall include all of the downstream bands in ascending order starting at f_1 (as shown in Figure A.1, Table B.1, Figure C.1) and ending at the highest band required for the highest frequency profile for which support is indicated. Up to four downstream bands may be defined. Each band shall be defined by a start subcarrier index and stop subcarrier index using 13 bits per index value. The subcarrier indices shall represent 4.3125 kHz subcarrier spacing. Adjacent downstream bands shall be coded as separate bands.
RFI Bands	This NPar(3) shall indicate in ascending order the start subcarrier index and stop subcarrier index for each RFI band in which the transmit PSD is to be reduced below -80 dBm/Hz. Each index is represented by 13 bits. Up to 16 RFI bands may be defined. The subcarrier indices shall represent 4.3125 kHz subcarrier spacing.
Initial IDFT Size ($2N$)	This NPar(3) indicates the initial downstream IDFT size that the VTU-O shall use at the beginning of the channel discovery phase, encoded as a number from 7 to 13 representing n , where $IDFTsize\ 2N = 2^n$
CE Lengths	This NPar(3) is a field of 15 bits representing the valid CE lengths: $2N/32$, $3N/32$, $4N/32$, ..., $16N/32$ inclusive. For each CE length that the VTU-O can support, the corresponding bit shall be set to ONE. The bit corresponding to $5N/32$ shall always be set to ONE.
Annex A US0	<p>A parameter block of 5 octets encoding the Annex A US0 capabilities. This block shall be coded as follows:</p> <ul style="list-style-type: none"> – Bits 1-6 of octet 1 and bits 1-4 of octet 2 shall be individually set to ONE to indicate support by a VTU-O of the corresponding Annex A US0 masks EU-32 through EU-128. – Bits 1-6 of octet 3 and bits 1-4 of octet 4 shall be individually set to ONE to indicate support by the VTU-O of the corresponding Annex A US0 masks ADLU-32 through ADLU-128. – Bit 1 of octet 5 shall be set to ONE to indicate that all supported Annex A US0 masks are also supported by the VTU-O for profile 12b. This bit may be set to ONE if profile 12b is supported. – Bit 2 of octet 5 shall be set to ONE to indicate that all supported Annex A US0 masks are also supported by the VTU-O for profile 17a. This bit may be set to ONE if profile 17a is supported.

Table 12-9 – VTU-O CL message NPar(3) bit definitions

ITU-T G.994.1 SPar(2) Bit	Definition of NPar(3) bits
Annex B US0	<p>A parameter block of 2 octets encoding the Annex B US0 capabilities. This block shall be coded as follows:</p> <ul style="list-style-type: none"> – Bits 1-3 of octet 1 shall be individually set to ONE to indicate support of the corresponding Annex B US0 masks by the VTU-O. – Bit 1 of octet 2 shall be set to ONE to indicate that all supported Annex B US0 masks are also supported by the VTU-O for profile 12b. This bit may be set to ONE if profile 12b is supported. – Bit 2 of octet 2 shall be set to ONE to indicate that all supported Annex B US0 masks are also supported by the VTU-O for profile 17a. This bit may be set to ONE if profile 17a is supported.
Annex C US0	<p>A parameter block of 3 octets encoding the Annex C US0 capabilities. This block shall be coded as follows:</p> <ul style="list-style-type: none"> – Bits 1-2 of octet 1 shall be individually set to ONE to indicate the support of the corresponding Annex C US0 Type(b) masks by the VTU-O. – Bits 1-2 of octet 2 shall be individually set to ONE to indicate the support of the corresponding Annex C US0 Type(co) masks by the VTU-O. – Bit 1 of octet 3 shall be set to ONE to indicate that all supported Annex C US0 masks are also supported by the VTU-O in the profile 12b. This bit may be set to ONE if profile 12b is supported. – Bit 2 of octet 3 shall be set to ONE to indicate that all supported Annex C US0 masks are also supported by the VTU-O in the profile 17a. This bit may be set to ONE if profile 17a is supported.

12.3.2.1.2 MS messages

A VTU-O selecting the ITU-T G.993.2 mode of operation in an ITU-T G.994.1 MS message shall do so by setting to ONE the SPar(1) ITU-T G.993.2 bit as defined in Table 11.0.4 of [ITU-T G.994.1]. The NPar(2) (Table 11.67 of [ITU-T G.994.1]) and SPar(2) (Table 11.68 of [ITU-T G.994.1]) fields corresponding to this bit are defined in Tables 12-10 and 12-11, respectively. For each ITU-T G.993.2 SPar(2) bit set to ONE, a corresponding NPar(3) field shall also be present (beginning with Table 11.68.1 in clause 9.4 of [ITU-T G.994.1]). Table 12-12 shows the definitions and coding for the VTU-O MS NPar(3) fields.

Table 12-10 – VTU-O MS message NPar(2) bit definitions

ITU-T G.994.1 NPar(2) Bit	Definition of NPar(2) bit
All-digital mode	Set to ONE if and only if both the last previous CLR and the last previous CL messages have set this bit to ONE. If set to ONE, indicates that both the VTU-O and the VTU-R shall be configured for operation in all-digital mode.
Support of downstream virtual noise	Set to ONE if and only if both the last previous CLR and the last previous CL messages have set this bit to ONE. Indicates that the downstream virtual noise mechanism may be used.
Lineprobe	Set to ONE if and only if both the last previous CLR and the last previous CL messages have set this bit to ONE. Indicates that the channel discovery phase of initialization shall include a lineprobe stage.
Loop Diagnostic mode	Set to ONE if either the last previous CLR or the last previous CL message has set this bit to ONE. Indicates that both VTUs shall enter loop diagnostic mode.

Table 12-10 – VTU-O MS message NPar(2) bit definitions

ITU-T G.994.1 NPar(2) Bit	Definition of NPar(2) bit
Support of PSD shaping in US0	Set to ONE if and only if both the last previous CLR and the last previous CL messages have set this bit to ONE. Indicates that the VTU-R supports PSD shaping in the US0 band.
Support of equalized FEXT UPBO	Set to ONE if and only if both the last previous CLR and the last previous CL messages have set this bit to ONE. Indicates that both the VTU-O and the VTU-R shall use equalized FEXT UPBO.
ITU-T G.993.5-friendly ITU-T G.993.2 operation in the downstream direction	See Table X.2
Full ITU-T G.993.5-friendly ITU-T G.993.2 operation	See Table Y.2.
Alternative electrical length estimation method	Set to ONE if and only if both the last previous CLR and the last previous CL messages have set this bit to ONE. Indicates that both the VTU-O and the VTU-R shall use electrical length estimation method ELE-M1.
Support of downstream SAVN	Set to ONE if and only if both the last previous CLR and the last previous CL messages have set this bit to ONE. Indicates that the downstream SAVN mechanism may be used.

Table 12-11 – VTU-O MS message SPar(2) bit definitions

ITU-T G.994.1 SPar(2) Bit	Definition of SPar(2) bit
Profiles	Always set to ONE.
Bands Upstream	Always set to ZERO.
Bands Downstream	Always set to ZERO
RFI Bands	Always set to ZERO.
Initial IDFT Size ($2N$)	Always set to ZERO.
CE Lengths	Shall be set to ONE if and only if both the last previous CLR and the last previous CL messages have set this bit to ONE. If set to ONE, indicates that the initial CE length to be used by both the VTU-O and the VTU-R shall be communicated in the corresponding NPar(3) field. If set to ZERO, the mandatory value shall be used.
Annex A US0 (Note)	May be set to ONE if and only if both the last previous CLR and the last previous CL messages have set this bit to ONE.
Annex B US0 (Note)	May be set to ONE if and only if both the last previous CLR and the last previous CL messages have set this bit to ONE.
Annex C US0 (Note)	May be set to ONE if and only if both the last previous CLR and the last previous CL messages have set this bit to ONE.
NOTE – One and only one of these bits shall be set to ONE.	

Table 12-12 – VTU-O MS message NPar(3) bit definitions

ITU-T G.994.1 SPar(2) Bit	Definition of NPar(3) bits
Profiles	Each valid profile is represented by one bit in a field of 8 bits. The valid profiles are: 8a, 8b, 8c, 8d, 12a, 12b, 17a and 30a. The profile selected by the VTU-O is indicated by setting its corresponding bit to ONE.
CE Lengths	This NPar(3) is a field of 15 bits representing the valid CE lengths 2N/32, 3N/32, 4N/32, ..., 16N/32 inclusive. The VTU-O shall indicate by setting to ONE the bit corresponding to the selected initial CE length. All other bits shall be set to ZERO. The selected CE length shall be one whose bit was set to ONE in both the last previous CLR and the last previous CL messages.
Annex A US0 (Note)	A parameter block of 5 octets encoding the Annex A US0 selection. The VTU-O shall indicate its selection of the Annex A US0 mask by setting to ONE the bit corresponding to that PSD mask. No more than one bit in this NPar(3) shall be set to ONE. The selected bit shall be set to ONE if and only if it was set to ONE in both the last previous CLR and the last previous CL messages and the selected profile supports US0 either explicitly or implicitly by its definition in Table 6-1. Bits 1-2 of octet 5 shall always be set to ZERO. If all bits are set to ZERO, the US0 band shall not be enabled.
Annex B US0 (Note)	A parameter block of 2 octets encoding the Annex B US0 selection. The VTU-O shall indicate its selection of the Annex B US0 PSD mask by setting to ONE the bit corresponding to that PSD mask. No more than one bit in this NPar(3) shall be set to ONE. The selected bit shall be set to ONE if and only if it was set to ONE in both the last previous CLR and the last previous CL messages, and the selected profile supports US0 either explicitly or implicitly by its definition in Table 6-1. Bits 1-2 of octet 2 shall always be set to ZERO. If all bits are set to ZERO, the US0 band shall not be enabled.
Annex C US0 (Note)	A parameter block of 3 octets encoding the Annex C US0 selection. The VTU-O shall indicate its selection of the Annex C US0 PSD mask by setting to ONE the bit corresponding to that PSD mask. No more than one bit in this NPar(3) shall be set to ONE. The selected bit shall be set to ONE if and only if it was set to ONE in both the last previous CLR and the last previous CL messages, and the selected profile supports US0 either explicitly or implicitly by its definition in Table 6-1. Bits 1-2 of octet 3 shall always be set to ZERO. If all bits are set to ZERO, the US0 band shall not be enabled.
NOTE – Support of US0 means the capability of the VTU-R to transmit US0 and the capability of the VTU-O to receive it.	

12.3.2.2 Handshake – VTU-R

A VTU-R, after power-up, loss of signal, or recovery from errors during the initialization procedure, shall enter the initial ITU-T G.994.1 state, R-SILENT0. The VTU-R may activate the link by transitioning to R-TONES-REQ. Alternatively, upon detection of C-TONES (VTU-O initiated activation), the VTU-R may transition to R-TONE1. Operation shall then continue in accordance with the procedures defined in [ITU-T G.994.1].

If ITU-T G.994.1 procedures select this Recommendation as the mode of operation, the VTU-R shall continue with ITU-T G.993.2 initialization at the conclusion of ITU-T G.994.1 operation.

12.3.2.2.1 CLR messages

A VTU-R wishing to indicate ITU-T G.993.2 capabilities in an ITU-T G.994.1 CLR message shall do so by setting to ONE the ITU-T G.993.2 SPar(1) bit as defined in Table 11.0.4 of [ITU-T G.994.1]. The NPar(2) (Table 11.67 of [ITU-T G.994.1]) and SPar(2) (Table 11.68 of [ITU-T G.994.1]) fields corresponding to the ITU-T G.993.2 SPar(1) bit are defined in Tables 12-13 and 12-14, respectively.

For each ITU-T G.993.2 SPar(2) bit set to ONE, a corresponding NPar(3) field shall also be present (beginning with Table 11.68.1 in clause 9.4 of [ITU-T G.994.1]). Table 12-15 shows the definitions and coding for the VTU-R CLR NPar(3) fields.

Table 12-13 – VTU-R CLR message NPar(2) bit definitions

ITU-T G.994.1 NPar(2) Bit	Definition of NPar(2) bit
All-digital mode	If set to ONE, signifies that the VTU-R supports all-digital mode.
Support of downstream virtual noise	If set to ONE, signifies that the VTU-R supports the use of the downstream virtual noise mechanism.
Lineprobe	Set to ONE if the VTU-R requests the inclusion of a lineprobe stage in initialization.
Loop Diagnostic mode	Set to ONE if the VTU-R requests loop diagnostic mode.
Support of PSD shaping in US0	If set to ONE, signifies that the VTU-R supports PSD shaping in the US0 band.
Support of equalized FEXT	If set to ONE, signifies that the VTU-R supports equalized FEXT UPBO.
ITU-T G.993.5-friendly ITU-T G.993.2 operation in the downstream direction	If set to ONE, signifies that the VTU-R supports Annex X.
Full ITU-T G.993.5-friendly ITU-T G.993.2 operation	If set to ONE, signifies that VTU-R supports Annex Y.
Alternative electrical length estimation method	If set to ONE, signifies that the VTU-R supports the Alternative Electrical Length Estimation Method (ELE-M1)
Support of downstream SAVN	If set to ONE, signifies that the VTU-R supports the use of the downstream SAVN mechanism.

Table 12-14 – VTU-R CLR message SPar(2) bit definitions

ITU-T G.994.1 SPar(2) Bit	Definition of SPar(2) bit
Profiles	Always set to ONE.
Bands Upstream	Always set to ZERO.
Bands Downstream	Always set to ZERO.
RFI Bands	Always set to ZERO.
Initial IDFT Size ($2N$)	Always set to ONE.
CE Lengths	If set to ZERO, indicates that the VTU-R can support only the mandatory CE length of $5N/32$ for the IDFT size equal to $2N$. If set to ONE, indicates that the VTU-R supports optional CE lengths in addition to the mandatory one.
Annex A US0 (Note)	If set to ONE, indicates that the corresponding NPar(3) shall indicate which of the US0 PSD masks described in Annex A are supported by the VTU-R.
Annex B US0 (Note)	If set to ONE, indicates that the corresponding NPar(3) shall indicate which of the US0 PSD masks described in Annex B are supported by the VTU-R.

Table 12-14 – VTU-R CLR message SPar(2) bit definitions

ITU-T G.994.1 SPar(2) Bit	Definition of SPar(2) bit
Annex C US0 (Note)	If set to ONE, indicates that the corresponding NPar(3) shall indicate which of the US0 PSD masks described in Annex C are supported by the VTU-R.
NOTE – At least one of these bits shall be set to ONE.	

Table 12-15 – VTU-R CLR message NPar(3) bit definitions

ITU-T G.994.1 SPar(2) Bit	Definition of NPar(3) bits
Profiles	Each valid profile is represented by one bit in a field of 8 bits. The valid profiles are: 8a, 8b, 8c, 8d, 12a, 12b, 17a and 30a. Each profile supported by the VTU-R is indicated by setting its corresponding bit to ONE.
Initial IDFT Size (2N)	This NPar(3) indicates the initial upstream IDFT size that the VTU-R shall use at the beginning of the channel discovery phase, encoded as a number from 6 to 13 representing n , where IDFTsize $2N = 2^n$
CE Lengths	This NPar(3) is a field of 15 bits representing the valid CE lengths $2N/32$, $3N/32$, $4N/32$, ..., $16N/32$, inclusive. For each supported CE length, the corresponding bit shall be set to ONE. The bit corresponding to $5N/32$ shall always be set to ONE.
Annex A US0	<p>A parameter block of 5 octets encoding the Annex A US0 capabilities. This block shall be coded as follows:</p> <ul style="list-style-type: none"> – Bits 1-6 of octet 1 and bits 1-4 of octet 2 shall be individually set to ONE to indicate support by a VTU-R of Annex A US0 masks EU-32 through EU-128. If bit 4 of octet 2 is set to ONE, the VTU-R shall also set the "Support of PSD shaping in US0" NPar(2) bit to ONE (see Table 12-13). – Bits 1-6 of octet 3 and bits 1-4 of octet 4 shall be individually set to ONE to indicate support by the VTU-R of Annex A US0 masks ADLU-32 through ADLU-128. If bit 4 of octet 4 is set to ONE, the VTU-R shall also set the "Support of PSD shaping in US0" NPar(2) bit to ONE (see Table 12-13). – Bit 1 of octet 5 shall be set to ONE to indicate that all supported Annex A US0 masks are also supported by the VTU-R in the profile 12b. This bit may be set to ONE if profile 12b is supported. – Bit 2 of octet 5 shall be set to ONE to indicate that all supported Annex A US0 masks are also supported by the VTU-R in the profile 17a. This bit may be set to ONE if profile 17a is supported.
Annex B US0	<p>A parameter block of 2 octets encoding the Annex B US0 capabilities. This block shall be coded as follows:</p> <ul style="list-style-type: none"> – Bits 1-3 of octet 1 shall be individually set to ONE to indicate support of the corresponding Annex B US0 masks by the VTU-R. – Bit 1 of octet 2 shall be set to ONE to indicate that all supported Annex B US0 masks are also supported by the VTU-R for profile 12b. This bit may be set to ONE if profile 12b is supported. – Bit 2 of octet 2 shall be set to ONE to indicate that all supported Annex B US0 masks are also supported by the VTU-R for profile 17a. This bit may be set to ONE if profile 17a is supported.

Table 12-15 – VTU-R CLR message NPar(3) bit definitions

ITU-T G.994.1 SPar(2) Bit	Definition of NPar(3) bits
Annex C US0	<p>A parameter block of 3 octets encoding the Annex C US0 capabilities. This block shall be coded as follows:</p> <ul style="list-style-type: none"> – Bits 1-2 of octet 1 shall be individually set to ONE to indicate the support of the corresponding Annex C US0 Type(b) masks by the VTU-R. – Bits 1-2 of octet 2 shall be individually set to ONE to indicate the support of the corresponding Annex C US0 Type(co) masks by the VTU-R. – Bit 1 of octet 3 shall be set to ONE to indicate that all supported Annex C US0 masks are also supported by the VTU-R in the profile 12b. This bit may be set to ONE if profile 12b is supported. – Bit 2 of octet 3 shall be set to ONE to indicate that all supported Annex C US0 masks are also supported by the VTU-R in the profile 17a. This bit may be set to ONE if profile 17a is supported.

12.3.2.2.2 MS messages

A VTU-R selecting ITU-T G.993.2 mode of operation in an ITU-T G.994.1 MS message shall do so by setting to ONE the ITU-T G.993.2 SPar(1) bit as defined in Table 11.0.4 of [ITU-T G.994.1]. The NPar(2) (Table 11.67 of [ITU-T G.994.1]) and SPar(2) (Table 11.68 of [ITU-T G.994.1]) fields corresponding to the ITU-T G.993.2 SPar(1) bit are defined in Tables 12-16 and 12-17, respectively. For each ITU-T G.993.2 SPar(2) bit set to ONE, a corresponding NPar(3) field shall also be present (beginning with Table 11.68.1 in clause 9.4 of [ITU-T G.994.1]). Table 12-18 shows the definitions and coding for the VTU-R MS NPar(3) fields.

Table 12-16 – VTU-R MS message NPar(2) bit definitions

ITU-T G.994.1 NPar(2) Bit	Definition of NPar(2) bit
All-digital mode	Set to ONE if and only if both the last previous CLR and the last previous CL messages have set this bit to ONE. If set to ONE, indicates that both the VTU-O and the VTU-R shall be configured for operation in all-digital mode.
Support of downstream virtual noise	Set to ONE if and only if both the last previous CLR and the last previous CL messages have set this bit to ONE. Indicates that the downstream virtual noise mechanism may be used.
Lineprobe	Set to ONE if and only if both the last previous CLR and the last previous CL messages have set this bit to ONE. Indicates that the channel discovery phase of initialization shall include a lineprobe stage.
Loop Diagnostic mode	Set to ONE if either the last previous CLR or the last previous CL message has set this bit to ONE. Indicates that both VTUs shall enter loop diagnostic mode.
Support of PSD shaping in US0	Set to ONE if and only if both the last previous CLR and the last previous CL messages have set this bit to ONE. Indicates that the VTU-R shall support PSD shaping in the US0 band.
Support of equalized FEXT	Set to ONE if and only if both the last previous CLR and the last previous CL messages have set this bit to ONE. Indicates that both the VTU-O and the VTU-R shall use equalized FEXT UPBO.

Table 12-16 – VTU-R MS message NPar(2) bit definitions

ITU-T G.994.1 NPar(2) Bit	Definition of NPar(2) bit
ITU-T G.993.5-friendly ITU-T G.993.2 operation in the downstream direction	See Table X.4
Full ITU-T G.993.5-friendly ITU-T G.993.2 operation	See Table Y.4.
Alternative electrical length estimation method	Set to ONE if and only if both the last previous CLR and the last previous CL messages have set this bit to ONE. Indicates that both the VTU-O and the VTU-R shall use ELE-M1.
Support of downstream SAVN	Set to ONE if and only if both the last previous CLR and the last previous CL messages have set this bit to ONE. Indicates that the downstream SAVN mechanism may be used.

Table 12-17 – VTU-R MS message SPar(2) bit definitions

ITU-T G.994.1 SPar(2) Bit	Definition of SPar(2) bit
Profiles	Always set to ONE.
Bands Upstream	Always set to ZERO.
Bands Downstream	Always set to ZERO
RFI Bands	Always set to ZERO.
Initial IDFT Size ($2N$)	Always set to ZERO.
CE Lengths	Shall be set to ONE if and only if both the last previous CLR and the last previous CL messages have set this bit to ONE. If set to ONE, indicates that the initial CE length to be used by both the VTU-O and the VTU-R shall be communicated in the corresponding NPar(3) field. If set to ZERO, the mandatory value shall be used.
Annex A US0 (Note)	May be set to ONE if and only if both the last previous CLR and the last previous CL messages have set this bit to ONE.
Annex B US0 (Note)	May be set to ONE if and only if both the last previous CLR and the last previous CL messages have set this bit to ONE.
Annex C US0 (Note)	May be set to ONE if and only if both the last previous CLR and the last previous CL messages have set this bit to ONE.
NOTE – One and only one of these bits shall be set to ONE.	

Table 12-18 – VTU-R MS message NPar(3) bit definitions

ITU-T G.994.1 SPar(2) Bit	Definition of NPar(3) bits
Profiles	Each valid profile is represented by one bit in a field of 8 bits. The valid profiles are: 8a, 8b, 8c, 8d, 12a, 12b, 17a and 30a. The profile selected by the VTU-R is indicated by setting its corresponding bit to ONE.
CE Lengths	This NPar(3) is a field of 15 bits representing the valid CE lengths 2N/32, 3N/32, 4N/32, ..., 16N/32, inclusive. The VTU-R shall indicate by setting to ONE the bit corresponding to the selected initial CE length. All other bits shall be set to ZERO. The selected CE length shall be one whose bit was set to ONE in both the last previous CLR and the last previous CL messages.
Annex A US0 (Note)	A parameter block of 5 octets encoding the Annex A US0 selection. The VTU-R shall indicate its selection of the Annex A US0 mask by setting to ONE the bit corresponding to that PSD mask. No more than one bit in this NPar(3) shall be set to ONE. The selected bit shall be set to ONE if and only if it was set to ONE in both the last previous CLR and the last previous CL messages and the selected profile supports US0 either explicitly or implicitly by its definition in Table 6-1. Bits 1-2 of octet 5 shall always be set to ZERO. If all bits are set to ZERO, the US0 band shall not be enabled.
Annex B US0 (Note)	A parameter block of 2 octets encoding the Annex B US0 selection. The VTU-R shall indicate its selection of the Annex B US0 mask by setting to ONE the bit corresponding to that PSD mask. No more than one bit in this NPar(3) shall be set to ONE. The selected bit shall be set to ONE if and only if it was set to ONE in both the last previous CLR and the last previous CL messages and the selected profile supports US0 either explicitly or implicitly by its definition in Table 6-1. Bits 1-2 of octet 2 shall always be set to ZERO. If all bits are set to ZERO, the US0 band shall not be enabled.
Annex C US0 (Note)	A parameter block of 3 octets encoding the Annex C US0 selection. The VTU-R shall indicate its selection of the Annex C US0 mask by setting to ONE the bit corresponding to that PSD mask. No more than one bit in this NPar(3) shall be set to ONE. The selected bit shall be set to ONE if and only if it was set to ONE in both the last previous CLR and the last previous CL messages and the selected profile supports US0 either explicitly or implicitly by its definition in Table 6-1. Bits 1-2 of octet 3 shall always be set to ZERO. If all bits are set to ZERO, the US0 band shall not be enabled.
NOTE – Support of US0 means the capability of the VTU-R to transmit US0 and the capability of the VTU-O to receive it.	

12.3.3 Channel discovery phase

12.3.3.1 Overview

The channel discovery phase is the first phase when VDSL2 signals are exchanged between VTUs. The following tasks are completed during channel discovery:

- Timing recovery and selection of pilot tone(s);
- Establish communication between the VTUs over the SOC;
- Exchange information necessary to set up the PSDs for both transmission directions; and
- Verify, adjust and exchange various parameter values necessary to enter the training phase (IDFT sizes, CE length, window length and others).

During the channel discovery phase, if the optional equalized FEXT UPBO method is not supported, the VTU-R shall determine the required UPBO based on the estimation of the electrical length of the

loop and on the values of parameters for the UPBO reference PSD (UPBOPSD) it receives from the VTU-O. If the optional equalized FEXT UPBO method is supported, the VTU-R shall use in addition the parameter UPBO reference electrical length (UPBOREFEL) it receives from the VTU-O, to determine the required UPBO. Both VTUs may perform additional PSD cut-back.

NOTE 1 – In regions of the spectrum not expected to be useable in showtime, the transceiver may reduce the value of the PSD from the beginning of Channel Discovery to prevent unnecessary crosstalk into other systems. A VTU may, for example, determine the tones where CDPSD can be reduced based on the received signal level and known transmit level of the ITU-T G.994.1 tones. A specific mechanism is vendor discretionary.

Figure 12-6 presents the timing diagram for the stages of the channel discovery phase. It gives an overview of the sequence of signals transmitted and the sequence of SOC messages sent by the VTU-O and VTU-R during the channel discovery phase. The two inner columns show the sequences of signals that are transmitted (see clause 12.3.3.3). The two outer columns show the messages that are sent over the SOC (see clause 12.3.3.2). The shaded areas correspond to periods of time when the SOC is in its inactive state.

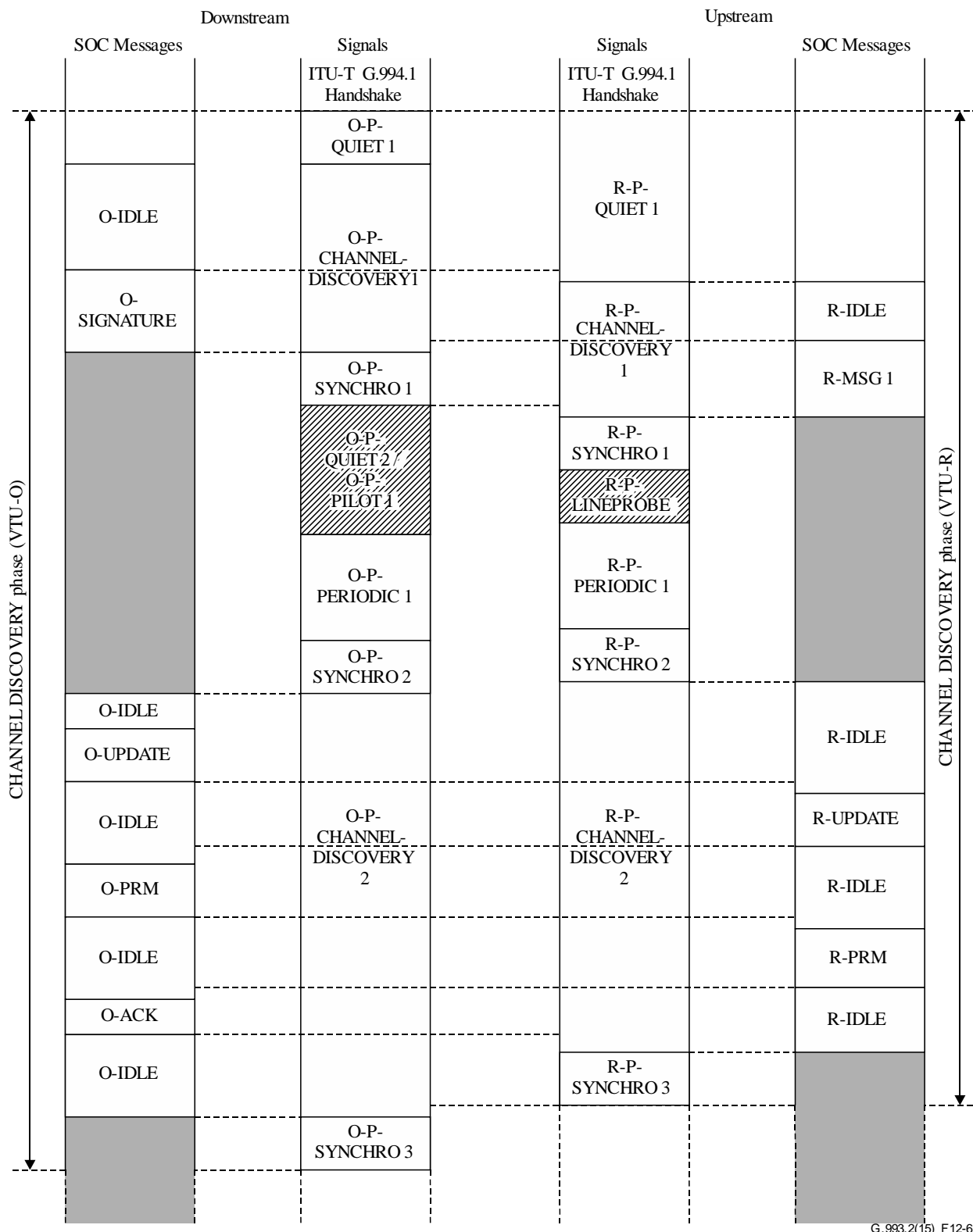

G.993.2(15)_F12-6

Figure 12-6 – Timing diagram for the stages of the channel discovery phase

NOTE 2 – In the exchange of the SOC messages identified in Figure 12-6, the rules of the communication protocol of clause 12.2.2 apply. Some messages sent in the SOC may require segmentation; although this is not shown in Figure 12-6, the segmented message elements and their corresponding acknowledgements are sent via the SOC per the communication protocol of clause 12.2.2.

The VTU-O shall initiate the start of the channel discovery phase with O-P-QUIET 1. During this stage, both VTUs are silent and a quiet line noise measurement can be performed. The duration of

O-P-QUIET 1 shall be at least 512 symbols but not longer than 1024 symbols. After completing the O-P-QUIET 1 stage, the VTU-O shall start transmitting O-P-CHANNEL DISCOVERY 1. The VTU-O shall send O-IDLE for a period of between 1500 and 2000 DMT symbols. It shall then send its first message, O-SIGNATURE. O-SIGNATURE shall be sent over the SOC in AR mode, as described in clause 12.2.2.1, and carries the information listed in Table 12-21.

The VTU-R shall start the channel discovery phase with R-P-QUIET 1 (no signal) until it correctly receives the O-SIGNATURE message. During the R-P-QUIET 1 stage, the VTU-R shall complete the timing lock prior to transmitting R-P-CHANNEL DISCOVERY 1. Upon receiving the O-SIGNATURE message, the VTU-R has all of the necessary information needed to perform UPBO (see clause 7.2.1.3). If AELE-MODE = 1, 2, or 3, UPBO shall be performed according to AELE-MODE=1 until final kl_0 values are provided in the O-UPDATE message. After performing UPBO, the VTU-R shall transmit R-P-CHANNEL DISCOVERY 1. The VTU-R shall transmit R-P-CHANNEL DISCOVERY 1 using the initial timing advance value received in the O-SIGNATURE message. The VTU-R shall send R-IDLE for at least 512 DMT symbols. It shall then send its first message, R-MSG 1, in AR mode. The VTU-R shall send R-MSG 1 until the VTU-O indicates it has correctly received R-MSG 1. The R-MSG 1 message conveys to the VTU-O the upstream PSD and other VTU-R parameters, as presented in Table 12-32.

The VTU-O shall indicate correct reception of the R-MSG 1 message by transmitting O-P-SYNCHRO 1, which shall be followed by transmission of O-P-PERIODIC 1 if a lineprobe stage is not requested. If a lineprobe stage is requested, the VTU-O shall transmit O-P-QUIET 2/O-P-PILOT 1 and transition to O-P-PERIODIC 1 640 symbols after the end of transmission of O-P-SYNCHRO 1. The request for a lineprobe stage is indicated by the parameter "Lineprobe" during the ITU-T G.994.1 handshake phase (see clause 12.3.2).

The VTU-R shall reply to O-P-SYNCHRO 1 by transmitting R-P-SYNCHRO 1 within a time period of 64 symbols after detection of O-P-SYNCHRO 1. This shall be followed by transmission of either R-P-PERIODIC 1 if a lineprobe stage is not requested, or R-P-LINEPROBE if a lineprobe stage is requested. The duration of R-P-LINEPROBE shall be 512 symbols. After R-P-LINEPROBE, the VTU-R shall transmit R-P-PERIODIC 1.

The VTU-O shall transmit O-P-PERIODIC 1 for a duration of 2 048 symbols and shall then transition to O-P-SYNCHRO 2. The VTU-R shall transmit R-P-PERIODIC 1 for a duration of 2 048 symbols and shall then transition to R-P-SYNCHRO 2. During the period of time that O-P-PERIODIC 1 and R-P-PERIODIC 1 are transmitted, the VTUs may perform SNR measurements.

Immediately after transmission of O-P-SYNCHRO 2, the VTU-O shall transmit O-P-CHANNEL DISCOVERY 2 while sending O-IDLE over the SOC.

After detection of R-P-SYNCHRO 2 and the end of transmission of O-P-SYNCHRO 2, the VTU-O shall send O-UPDATE after a time period of between 48 and 64 symbols, inclusive, to update the parameters of the VTU-R, specifically the PSD of the VTU-R. The O-UPDATE message may also include corrections to the UPBO settings, and additional power cut-back. The parameters conveyed by O-UPDATE are presented in Table 12-28.

The O-UPDATE message and all subsequent SOC messages from the VTU-O shall be sent only once, using the RQ protocol described in clause 12.2.2.2, which allows the receiving VTU to ask for a retransmission of incorrectly received or missing messages.

The VTU-R shall start transmitting R-P-CHANNEL DISCOVERY 2 immediately after transmission of R-P-SYNCHRO 2, while sending R-IDLE over the SOC. All messages sent by the VTU-R starting from those sent during R-P-CHANNEL DISCOVERY 2 shall be sent using the RQ protocol described in clause 12.2.2.2.

After the VTU-R receives the O-UPDATE message, it shall send R-UPDATE to request an update of the downstream PSD and other parameters of the VTU-O, which may include downstream power

cut-back. The list of parameters subject to update at the VTU-O and the VTU-R are listed in Table 12-35 and Table 12-28, respectively.

The R-UPDATE message shall be acknowledged by the VTU-O by sending O-PRM over the SOC. O-PRM shall contain the final values of the modulation parameters and PSDs to be used in the training phase. The content of O-PRM is presented in Table 12-30. The VTU-R shall acknowledge O-PRM by sending R-PRM (see Table 12-36), which reports settings of VTU-R modulation parameters, including those requested to be updated in O-UPDATE.

The VTU-O shall acknowledge the reception of the R-PRM message by sending O-ACK. Upon reception of the O-ACK message, the VTU-R shall complete the channel discovery phase in the upstream direction by transmitting R-P-SYNCHRO 3. The VTU-O shall reply by transmitting O-P-SYNCHRO 3 within a time period of 64 symbols. The transmission of O-P-SYNCHRO 3 completes the channel discovery phase in the downstream direction.

All parameter value changes and PSD changes negotiated during the channel discovery phase relative to those indicated in O-SIGNATURE and R-MSG 1 shall be applied in the downstream direction from the first symbol following O-P-SYNCHRO 3 and in the upstream direction from the first symbol following R-P-SYNCHRO 3.

NOTE 3 – A change in modulation parameters (such as CE length) may result in the transmission of several corrupt symbols in the downstream direction and a temporary loss of synchronization at the VTU-R receiver. At the start of the training phase, there is a period of time to recover synchronization.

The signals and SOC messages sent by the VTU-O during the channel discovery phase are summarized in Table 12-19, and the signals and SOC messages sent by the VTU-R during the channel discovery phase are summarized in Table 12-20. The protocol used for SOC messages is provided, where applicable, in parentheses in the column labelled "SOC state".

Table 12-19 – VTU-O signals and SOC messages in the channel discovery phase

Signal	Signal type	Signal duration in DMT symbols with CE	SOC messages	SOC state
O-P-QUIET 1	None	512 to 1024	None	Inactive
O-P-CHANNEL DISCOVERY 1	Non-periodic	Variable	O-SIGNATURE	Active (AR)
O-P-SYNCHRO 1	Non-periodic	15	None	Inactive
O-P-PILOT 1	Non-periodic	640	None	Inactive
O-P-QUIET 2	None	640	None	Inactive
O-P-PERIODIC 1	Periodic	2048	None	Inactive
O-P-SYNCHRO 2	Non-periodic	15	None	Inactive
O-P-CHANNEL DISCOVERY 2	Non-periodic	Variable	O-UPDATE, O-PRM, O-ACK	Active (RQ)
O-P-SYNCHRO 3	Non-periodic	15	None	Inactive

Table 12-20 – VTU-R signals and SOC messages in the Channel Discovery phase

Signal	Signal type	Signal duration in DMT symbols with CE	SOC messages	SOC state
R-P-QUIET 1	None	Variable	None	Inactive
R-P-CHANNEL DISCOVERY 1	Non-periodic	Variable	R-MSG 1	Active (AR)
R-P-SYNCHRO 1	Non-periodic	15	None	Inactive
R-P-LINEPROBE	Vendor Discretionary	512	None	Inactive
R-P-PERIODIC 1	Periodic	2048	None	Inactive
R-P-SYNCHRO 2	Non-periodic	15	None	Inactive
R-P-CHANNEL DISCOVERY 2	Non-periodic	Variable	R-UPDATE, R-PRM	Active (RQ)
R-P-SYNCHRO 3	Non-periodic	15	None	Inactive

12.3.3.2 SOC message exchange during the channel discovery phase

Figure 12-7 illustrates the SOC message exchange between the VTU-O and VTU-R during the channel discovery phase. It also summarizes the content of each message.

The messages sent by the VTU-O are described in detail in clause 12.3.3.2.1. The messages sent by the VTU-R are described in detail in clause 12.3.3.2.2.

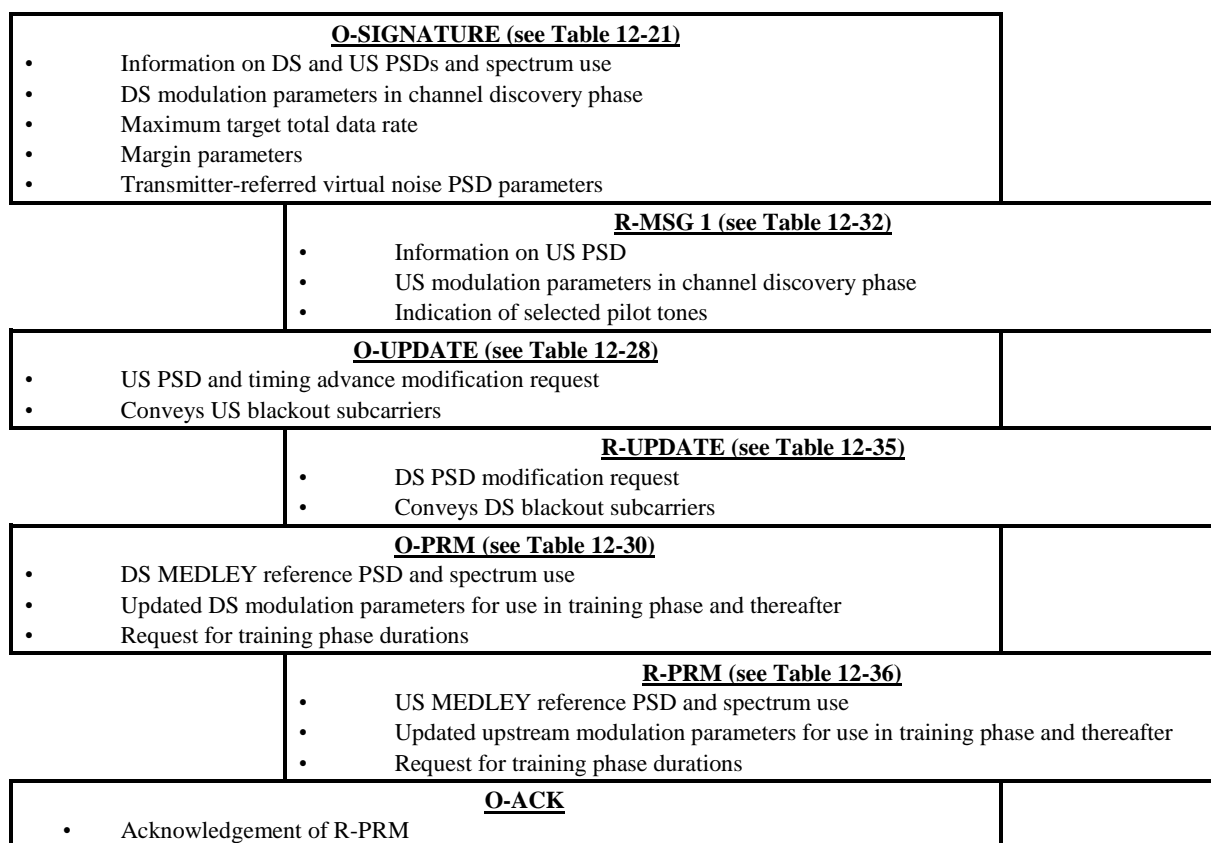

Figure 12-7 – SOC message exchange during the channel discovery phase

12.3.3.2.1 VTU-O messages sent during the Channel Discovery phase

12.3.3.2.1.1 O-SIGNATURE

The full list of parameters carried by the O-SIGNATURE message is shown in Table 12-21.

Table 12-21 – Description of message O-SIGNATURE

	Field name	Format
1	Message descriptor	Message code
2	Supported subcarriers in the downstream direction (SUPPORTEDCARRIERS _{ds} set)	Bands descriptor
3	Supported subcarriers in the upstream direction (SUPPORTEDCARRIERS _{us} set)	
4	Downstream transmit PSD mask (PSDMASK _{ds})	PSD descriptor
5	Upstream transmit PSD mask (PSDMASK _{us})	
6	Channel discovery downstream PSD (CDPSD _{ds})	
7	Initial downstream PSD ceiling (CDMAXMASK _{ds})	2 bytes
8	Downstream nominal maximum aggregate transmit power (MAXNOMATP _{ds})	2 bytes
9	Parameters for UPBO reference PSD (UPBOPSD)	UPBOPSD descriptor
10	Maximum target total data rate	2 bytes
11	Downstream maximum SNR margin (MAXSNRM _{ds})	2 bytes
12	Downstream target SNR margin (TARSNRM _{ds})	2 bytes
13	Downstream transmit window length (β_{ds})	1 byte
14	Downstream cyclic prefix	2 bytes
15	Initial value of timing advance	2 bytes
16	Downstream transmitter-referred virtual noise PSD (TXREFVN _{ds})	PSD descriptor
17	SNRM_MODE	1 byte
18	Upstream transmitter-referred virtual noise PSD (TXREFVN _{us})	PSD descriptor
19	UPBO Reference electrical length (UPBOREFEL)	UPBOREFEL descriptor
20	ITU-T G.998.4 parameter field	Variable length
21	ITU-T G.993.5 parameter field A	Variable length
22	Alternative Electrical Length Estimation Mode Control	2 bytes AELE-MODE Control descriptor
23	Reserved for operation according to Annex X	1 byte
24	ITU-T G.993.5 parameter field B	Variable length

Field #1 "Message descriptor" is a unique one-byte code that identifies the message. See Table 12-6 for a complete list of codes.

Field #2 "Supported subcarriers in the downstream direction (SUPPORTEDCARRIERS_{ds})" conveys information about the subcarriers that are allocated for transmission in the downstream direction. It allows the operator to specify exactly which subcarriers are available for the downstream direction. No more than 32 bands shall be specified.

Field #3 "Supported subcarriers in the upstream direction (SUPPORTEDCARRIERS_{us})" conveys information about the subcarriers that are allocated for transmission in the upstream direction. It

allows the operator to specify exactly which subcarriers are available for the upstream direction. No more than 32 bands shall be specified.

Fields #2 and #3 shall be formatted as "bands descriptors". The format of the bands descriptor shall be as shown in Table 12-22.

Table 12-22 – Bands descriptor

Octet	Content of field
1	Number of bands to be described
2-4	Bits 0-11: Index of the first subcarrier in band 1 Bits 12-23: Index of the last subcarrier in band 1
5-7 (if applicable)	Bits 0-11: Index of the first subcarrier in band 2 Bits 12-23: Index of the last subcarrier in band 2
etc.	etc.

The first octet of the bands descriptor shall contain the number of bands to be described. This number can be zero. In that case, there shall be no further octets in the descriptor. If the number of bands is not equal to zero, each group of three consecutive octets in the descriptor shall describe the first and last subcarrier in a band.

The first 12 bits (0-11) in the group of three octets shall contain the index of the subcarrier at the lower edge of the band. The last 12 bits (12-23) shall contain the index of the subcarrier at the upper edge of the band. The first and last subcarriers shall be included in the band. For example, a field value 400200_{16} means that all subcarriers from $200_{16} = 512$ to $400_{16} = 1024$, including subcarriers 512 and 1024, are included in the set.

Field #4 "Downstream transmit PSD mask (PSDMASKDs)" indicates the PSD mask, for both the passband and the stopbands (see clauses 7.2.1 and 7.2.2), that is allowed in the downstream direction. The "PSD descriptor" format specified in Table 12-23 shall be used, and the number of subcarriers being described shall be limited to ≤ 48 . This information shall be taken into account when performing the downstream PSD updates during the channel discovery phase. The VTU-O shall comply with this constraint at all times. In addition, VTU-O shall comply with the requirements in the RFI bands specified during the ITU-T G.994.1 handshake phase, as specified in clause 12.3.2.

Field #5 "Upstream transmit PSD mask (PSDMASKUs)" indicates the PSD mask, for both the passband and the stopbands (see clauses 7.2.1 and 7.2.2), that is allowed in the upstream direction. The "PSD descriptor" format specified in Table 12-23 shall be used, and the number of subcarriers being described shall be limited to ≤ 32 . This information shall be taken into account when performing the upstream PSD updates during the channel discovery phase. The VTU-R shall comply with this constraint at all times. In addition, the VTU-R shall always comply with the UPBO requirements, which may further reduce the upstream transmit PSD to below the upstream transmit PSD mask, as specified in clause 7.2.1.3, and with the requirements in the RFI bands specified during the ITU-T G.994.1 handshake phase, as specified in clause 12.3.2.

Field #6 "Channel discovery downstream PSD (CDPSDDs)" indicates the PSD at the U interface in the downstream direction during the channel discovery phase. The "PSD descriptor" format specified in Table 12-23 shall be used, and the number of subcarriers being described shall be limited to ≤ 48 . The only valid PSD values obtained by the receiver using the interpolation procedure specified are for those subcarriers that belong to the SUPPORTEDCARRIERSds set, excluding the RFI bands communicated during the ITU-T G.994.1 handshake phase. PSD values out of this set shall be ignored by the receiver. The valid CDPSDDs values shall be at least 3.5 dB below the downstream transmit PSD mask (Field #4) and at least 3.5 dB below the initial downstream PSD ceiling (Field #7).

Moreover, the valid values of CDPSDs, either those which are directly communicated or those obtained at the receiver by interpolation, shall not deviate from the actual values of the transmit PSD, as measured in the reference impedance at the U interface, by more than 1 dB.

Table 12-23 – PSD descriptor

Octet	Content of field
1	Number of subcarriers (or breakpoints) being described
2-4	Bits 0-11: Index of first subcarrier being described Bits 12-23: PSD level in steps of 0.1 dB with an offset of -140 dBm/Hz
5-7 (if applicable)	Bits 0-11: Index of second subcarrier being described Bits 12-23: PSD level in steps of 0.1 dB with an offset of -140 dBm/Hz
etc.	etc.

The first octet of the descriptor shall contain the number of breakpoints being specified. This number can be zero. In that case, there shall be no additional octets in the descriptor. If the number of breakpoints is not equal to zero, each group of three consecutive octets shall describe one breakpoint as a PSD value at a certain subcarrier index.

The first 12 bits (0-11) in the group of three octets shall contain the index of the subcarrier. The last 12 bits (12-23) shall contain the PSD level. The PSD level shall be an integer multiple of 0.1 dB with an offset of -140 dBm/Hz. For example a field value of 320400_{16} means a PSD of $320_{16} \times 0.1 - 140 = -60$ dBm/Hz on subcarrier index $400_{16} = 1024$. The PSD level of intermediate unspecified subcarriers shall be obtained using a linear interpolation between the given PSD points (in dBm/Hz) with the frequency axis expressed in a linear scale. The subcarrier indices of the specified breakpoints may be either determined by the CO-MIB or vendor discretionary.

NOTE 1 – Breakpoints should be selected such that the PSD between the breakpoints obtained using linear interpolation is sufficiently close to the PSD that is being described.

Field #7 "Initial downstream PSD ceiling (CDMAXMASKds)" indicates the PSD level that is used to impose a ceiling on the downstream transmit PSD mask to form the downstream PSD mask of the signals transmitted during the channel discovery phase, on which the downstream channel discovery PSD (CDPSDs) is based (see Field #6). The field shall be coded as a 16-bit value with the LSB weight of -0.1 dBm/Hz. The valid values are in the range from 0 dBm/Hz to -90 dBm/Hz in 0.1 dB steps.

Field #8 "Downstream nominal maximum aggregate transmit power (MAXNOMATPs)" indicates the maximum wide-band power that the VTU-O is allowed to transmit. The value shall be expressed in dBm (10.3.4.2.1). This field shall be coded as a 9-bit two's complement signed integer with the LSB weight of 0.1 dBm and the valid range from -25.6 dBm to $+25.6$ dBm. The spare MSBs shall be set to the value of the sign bit.

Field #9 "UPBO reference PSD (UPBOPSD)" contains the parameters to compute the reference PSD that shall be used for the calculation of UPBO as specified in clause 7.2.1.3. One set of UPBOPSD parameters (a' , b') is defined per upstream band. The values of a' and b' are positive and shall be formatted as shown in Table 12-24.

Table 12-24 – UPBOPSD descriptor

Octet	Content of field
1	Number of US bands
2-4	bits 0-11: value of a' for US1 bits 12-23: value of b' for US1
5-7 (if applicable)	bits 0-11: value of a' for US2 bits 12-23: value of b' for US2
etc.	etc.
$3 \times n_{us} - 1, 3 \times n_{us} + 1$	bits 0-11: value of a' for US(n_{us}) bits 12-23: value of b' for US(n_{us})

The length of the field is variable and depends on the number of upstream bands exchanged during the ITU-T G.994.1 handshake phase of initialization (n_{us}), except US0. Parameters a' and b' shall be coded as 12-bit unsigned integers. The value of a is obtained by multiplying a' by 0.01 and adding it to 40. The range of values for a is between 40 and 80.96. The value of b is obtained by multiplying b' by 0.01. This allows values of b between 0 and 40.96 (see clause 7.2.1.3.2). For those upstream bands in which UPBO shall not be applied, all 12 bits representing values a' and b' shall be set to ZERO (which corresponds to $a = 40, b = 0$).

NOTE 2 – The granularity of 0.01 may be finer than needed for practical purposes, but it has been chosen to be able to transmit the values of b specified in regional VDSL standards referred to in [ITU-T G.993.1].

Field #10 "Maximum target total data rate" is the VTU-O's estimate of the maximum downstream total data rate that will be required during the operation of the VTU. The VTU-R may use this information to determine the amount of downstream power cut-back (the downstream PSD ceiling) and the spectrum to be used for downstream transmission (e.g., the highest downstream subcarrier) that is allowed to be used during the channel discovery phase.

NOTE 3 – The CO should determine an appropriate value of the maximum target total data rate based on the configuration parameters of the bearer channels, such as minimum INP (INP_{min_n}), maximum delay ($delay_{max_n}$), and minimum and maximum net data rates (net_{min_n}, net_{max_n}), provided in the MIB. The knowledge of the minimum INP and maximum delay can be used to estimate the coding overhead r_n , which is the main factor determining the relation between the net data rate assigned for the bearer channel n and the corresponding total data rate:

$$r_n = \frac{total_data_rate_n}{net_data_rate_n} = \frac{1}{1 - \frac{2 \times INP_{min_n}}{delay_{max_n} \times f_s}}$$

where $delay_{max_n}$ is in milliseconds and f_s is the data symbol rate in ksymbols/s. Knowledge of the net data rates and of the overhead rates of the bearer channels in use allows the VTU-O to make an estimate of the maximum downstream total data rate.

The field shall be coded as an unsigned integer representing the total data rate as a multiple of 8 kbit/s.

Field #11 "Downstream maximum SNR margin (MAXSNRMds)" indicates the maximum SNR margin the VTU-R receiver shall try to sustain. The definition and use of this parameter shall be the same as for the parameter "downstream maximum noise margin (MAXSNRMds)" specified in [ITU-T G.997.1]. The field shall be formatted as a 16-bit unsigned integer with LSB weight of 0.1 dB and the valid range between 0 and 31 dB. The special value defined in [ITU-T G.997.1] shall be coded as $FFFF_{16}$.

Field #12 "Downstream target SNR margin (TARSNRMds)" indicates the target SNR margin of the VTU-R receiver. The definition and use of this parameter shall be the same as for the parameter "downstream target noise margin (TARSNRMds)" specified in [ITU-T G.997.1]. The format used shall be the same as for Field #11 of the O-SIGNATURE message.

Field #13 "Downstream transmit window length (β_{ds})" shall contain the length of the downstream transmit window, (β_{ds}), expressed in samples at the downstream sampling rate corresponding to the IDFT size communicated during the ITU-T G.994.1 handshake phase. The value shall be coded as an 8-bit integer.

Field #14 "Downstream cyclic prefix" shall contain the length of the downstream cyclic prefix expressed in samples at the downstream sampling rate corresponding to the IDFT size communicated during the ITU-T G.994.1 handshake phase. The value shall be coded as a 16-bit integer.

Field #15 "Initial value of timing advance" indicates the initial timing advance, and shall be expressed in samples at the upstream sampling rate corresponding to the IDFT size communicated during the ITU-T G.994.1 handshake phase. The value shall be encoded in a 16-bit field using twos complement format. The special value of $7FFF_{16}$ indicates that the VTU-R shall select the initial setting of the timing advance.

NOTE 4 – The optimal value of the timing advance is a function of loop length (see clause 10.4.5.3). The initial value should be applicable for most loop lengths. It is suggested to choose an initial value that corresponds to a loop length of 1500 m. This value can be updated later in the initialization.

Field #16 "Downstream transmitter referred virtual noise PSD (TXREFVNds)" indicates the PSD of the virtual noise in the downstream direction for SNRM_MODE=2 and SNRM_MODE=4. For SNRM_MODE=5, this field indicates the initial value of the downstream SAVN PSD (TXREFSAVNds, see clause 11.4.1.1.6.1.5). This information shall be taken into account when determining the SNR margin (for optional SNRM_MODE=2, optional SNRM_MODE=4, and optional SNRM_MODE=5), which in turn shall be taken into account in determining the possible power cutback during the channel discovery phase, and for performing the bit loading later in initialization. The "PSD descriptor" format specified in Table 12-23 shall be used, and the number of subcarriers being described shall be limited to ≤ 32 . When SNRM_MODE = 1, the PSD descriptor field shall contain zero breakpoints (only 1 byte with a value of zero).

NOTE 5 - For SNRM_MODE=5, the TXREFVNds parameter provided by the CO-MIB may be taken into account by the VTU-O to determine the initial value of TXREFSAVNds (see clause 11.4.1.1.6.1.5).

Field #17 "SNRM_MODE" indicates the mode of downstream and upstream SNRM computation as described in clause 11.4.1.1.6. Bits 0 to 3 of the field shall be used to indicate the downstream SNR mode with valid values of 0_{16} (Downstream SNRM_MODE=1, mandatory), 1_{16} (Downstream SNRM_MODE=2, optional), 3_{16} (Downstream SNRM_MODE=4, optional), and 4_{16} (Downstream SNRM_MODE=5, optional). All other values are reserved. Bits 4 to 7 of the field shall be used to indicate the upstream SNR mode with valid values of 0_{16} (Upstream SNRM_MODE=1, mandatory), 1_{16} (Upstream SNRM_MODE=2, optional), 2_{16} (Upstream SNRM_MODE=3, optional), 3_{16} (Upstream SNRM_MODE = 4, optional), and 4_{16} (Upstream SNRM_MODE=5, optional). All other values are reserved.

Field #18 "Upstream transmitter referred virtual noise PSD (TXREFVNus)" indicates the PSD of the virtual noise in the upstream direction. The "PSD descriptor" format specified in Table 12-23 shall be used, and the number of subcarriers being described shall be limited to ≤ 16 . When SNRM_MODE = 1, 3, 4 or 5, the PSD descriptor field shall contain zero breakpoints (only 1 byte with a value of zero).

NOTE 5 – Improper setting of TXREFVN or RXREFVN can interact with the setting of one or more of the following parameters: maximum net data rate, downstream maximum SNR margin, impulse noise protection, and maximum interleaving delay. This interaction can result in high levels of transmit power that can lead to high crosstalk experienced by DSLs on other pairs in the same binder.

Field #19 "UPBO reference electrical length (UPBOREFEL)" contains the kl_{0_REF} parameters for the calculation of UPBO according to the optional equalized FEXT UPBO method, as specified in clause 7.2.1.3. One value of the parameter kl_{0_REF} is defined per upstream band. The values of kl_{0_REF} shall be formatted as shown in Table 12-25.

The length of the field is variable and depends on the number of upstream bands (n_{us}) exchanged during the ITU-T G.994.1 handshake phase of initialization, except US0. The value shall be coded as a 16-bit unsigned integer with an LSB weight of 0.1 dB. The valid range of values is from 1.8 to 63.0 dB with a 0.1 dB step, and a special value 0. The use of the special value 0 is described in clause 7.2.1.3.

Table 12-25 – UPBOREFEL descriptor

Octet	Content of field
1	Number of US bands
2-3	bits 0-15: value of kl_{0_REF} for US1
4-5 (if applicable)	bits 0-15: value of kl_{0_REF} for US2
...	
$2 \times n_{us}, 2 \times n_{us} + 1$	bits 0-15: value of kl_{0_REF} for US(n_{us})

Field #20 is a variable length field consisting of an integer number of bytes. It is formatted as shown in Table 12-26.

Field #21 is a variable length field consisting of an integer number of bytes. It is formatted as shown in Table 12-26.

Table 12-26 – Format of variable length fields #20 and #21

Octet	Name	Format	Description
1	Data length	1 byte	Number of bytes in the Data field (i.e., N-1). This is the number of bytes following this octet (see Note 1)
2-N	Data	N-1 bytes	N-1 data bytes, with N-1 being equal to the number contained in Octet #1 (see Note 2).
NOTE 1 – The number of bytes in the Data field could be zero. In that case, the variable length field consists of a single byte (i.e., N=1) with value 00 ₁₆ .			
NOTE 2 – The N represents the length of the variable length field in bytes.			

The actual data in the variable length fields #20 and #21 are beyond the scope of this Recommendation. For a correct interpretation at the receiver, support of either [ITU-T G.998.4] or [ITU-T G.993.5] or both is required. However, support of those Recommendations is not implied or required for compliance with Recommendation ITU-T G.993.2.

If the VTU-O does not support [ITU-T G.998.4], the ITU-T G.998.4 parameter field shall be a single byte with value 00₁₆.

If the VTU-O does not support [ITU-T G.993.5], the ITU-T G.993.5 parameter field A shall be a single byte with value 00₁₆.

Field #22 "Alternative Electrical Length Estimation Mode Control" has 2 bytes containing parameters: Alternative Electrical Length Estimation Mode (AELE-MODE), UPBO Electrical Length Minimum Threshold (UPBOELMT), and RXTHRSHDS as shown in Table 12-27, with the parameters specified in clause 7.2.1.3.2.1.2.

Table 12-27 – AELE-MODE Control Descriptor

Octet	Content of field
1	Bits 0 to 3: UPBOELEM values expressed as 4-bits unsigned integer in percent (Note). Bits 4 to 5: reserved by ITU and set to 0. Bits 6 to 7: value AELE-MODE expressed as 2-bit unsigned integer.
2	RXTHRSHDS parameter coded as an eight bit signed integer n , with valid values being all integers in the range from -64 to 0, representing an offset from -100 dBm/Hz as $RXTHRSHDS = (-100 + n)$ dBm/Hz.
NOTE – The only valid value of UPBOELEM is 10. Other values are reserved for future use.	

Field #23 is reserved for operation according to Annex X (see clause X.2.2.1a.1.1). This field shall be set to 00₁₆ if the selected mode of operation is not according to Annex X, and have a value as defined in Table X.5a otherwise.

Field #24 is a variable length field consisting of an integer number of bytes. It is formatted as shown in Table 12-27a.

Table 12-27a – Format of variable length field #24

Octet	Name	Format	Description
1-2	Data length	2 bytes	Number of bytes in the Data field (i.e., N-2). This is the number of bytes following these 2 octets (see Note 1).
3-N	Data	N-2 bytes	N-2 data bytes, with N-2 being equal to the number contained in Octets #1-2 (see Note 2).
NOTE 1 – The number of bytes in the Data field could be zero. In that case, the variable length field consists of 2 bytes long (i.e., N=2) with value 0000 ₁₆ .			
NOTE 2 – The N represents the length of the variable length field in bytes.			

The actual data in the variable length field #24 is beyond the scope of this Recommendation. For a correct interpretation at the receiver, support of [ITU-T G.993.5] is required. However, support of [ITU-T G.993.5] is not implied or required for compliance with this Recommendation.

If the VTU-O does not support [ITU-T G.993.5], the ITU-T G.993.5 parameter field B shall be 2 bytes long with value 0000₁₆.

12.3.3.2.1.2 O-UPDATE

The full list of parameters carried by the O-UPDATE message is shown in Table 12-28.

Table 12-28 – Description of message O-UPDATE

	Field name	Format
1	Message descriptor	Message code
2	Final electrical length	2 bytes
3	Updated upstream PSD ceiling (MAXMASKus)	2 bytes
4	Highest allowed upstream subcarrier	2 bytes
5	Lowest allowed upstream subcarrier	2 bytes

Table 12-28 – Description of message O-UPDATE

	Field name	Format
6	BLACKOUT _{us} set	Bands descriptor
7	Timing advance correction	2 bytes
8	ITU-T G.998.4 parameter field	Variable length
9	ITU-T G.993.5 parameter field	Variable length
10	Extended final electrical length	UPBOXFEL descriptor

Field #1 "Message descriptor" is a one-byte code that identifies the message. See Table 12-6 for a complete list of codes.

Field #2 "Final electrical length" contains the electrical length expressed in dB at 1 MHz (see clause 7.2.1.3.2) that the VTU-R shall use to set its upstream PSD starting from the training phase onward. The value shall be coded as a 16-bit number with the LSB weight of 0.1 dB. The valid range of values is from 0 dB to 128 dB with a 0.1 dB step. This value may be different from the value reported by the VTU-R in R-MSG 1 and shall be used by the VTU-R to determine the UPBOMASK, as specified in clause 7.2.1.3.2. This updated UPBOMASK shall be used to form the upstream MEDLEY reference PSD mask (Field #2 of R-PRM).

Field #3 "Updated upstream PSD ceiling (MAXMASK_{us})" indicates the PSD ceiling level of the upstream transmit PSD mask. This field shall be coded the same as Field #7 of O-SIGNATURE. If this level is lower than the upstream PSD ceiling indicated in R-MSG 1, the VTU-R shall apply this new ceiling level to PSDMASK_{us}. Otherwise, the VTU-R may increase the ceiling of the upstream PSD mask up to MAXMASK_{us}. This new ceiling level shall be used to form the upstream MEDLEY reference PSD mask (MREFMASK_{us}). A special value 1000₁₆ shall indicate no limit to the upstream PSD ceiling level (under the constraints of the upstream transmit PSD mask).

Field #4 "Highest allowed upstream subcarrier" contains the index of the highest frequency upstream subcarrier that is allowed to be used by the VTU-R. The format shall be a 16-bit value. The subcarrier index shall be described as 12 bits. The four MSBs of the field shall be set to ZERO. The VTU-R shall not allocate power to subcarriers above the highest allowed upstream subcarrier.

Field #5 "Lowest allowed upstream subcarrier" contains the index of the lowest-frequency upstream subcarrier that is allowed to be used by the VTU-R. The format shall be a 16-bit value. The subcarrier index shall be described as 12 bits. The four MSBs of the field shall be set to ZERO. The VTU-R shall not allocate power to subcarriers below the lowest allowed upstream subcarrier.

Field #6 "BLACKOUT_{us} set" contains the BLACKOUT set of subcarriers in the upstream direction. The field shall be formatted as a "bands descriptor" (see Table 12-22) with a maximum number of 16 bands. If there are no blackout subcarriers, the field shall consist of one octet, 00₁₆.

Field #7 "Timing advance correction" contains the timing advance correction with respect to the currently used timing advance expressed in samples at the upstream sampling rate corresponding to the IDFT size communicated during the ITU-T G.994.1 handshake phase. The value shall be encoded in a 16-bit field using twos complement format. Positive values shall indicate that the transmitted symbol will be advanced more with respect to the received symbol.

Field #8 is a variable length field consisting of an integer number of bytes. It is formatted as shown in Table 12-26.

Field #9 is a variable length field consisting of an integer number of bytes. It is formatted as shown in Table 12-26.

The actual data in the variable length fields 8 and 9 are beyond the scope of this Recommendation. For a correct interpretation at the receiver, support of either [ITU-T G.998.4] or [ITU-T G.993.5] or both is required. However, support of those Recommendations is not implied or required for compliance with Recommendation ITU-T G.993.2.

If the VTU-O does not support [ITU-T G.998.4], the ITU-T G.998.4 parameter field shall be a single byte with value 0.

If the VTU-O does not support [ITU-T G.993.5], the ITU-T G.993.5 parameter field shall be a single byte with value 0.

Field #10 "Extended final electrical length" contains the electrical length. The UPBOXFEL descriptor has the parameter $kl_0[band]$ for each upstream band expressed in dB at 1 MHz (see Table 12-29, with the parameter specified in clause 7.2.1.3.2.1.2) that the VTU-R shall use to set its upstream PSD starting from the training phase onward. The value shall be coded as a 16-bit number with the LSB weight of 0.1 dB. The valid range of values is from 0 dB to 128 dB with a 0.1 dB step. This value may be different from the value reported by the VTU-R in R-MSG 1 and shall be used by the VTU-R to determine the UPBOMASK, as specified in clause 7.2.1.3.2.3. This updated UPBOMASK shall be used to form the upstream MEDLEY reference PSD mask (Field #2 of R-PRM).

One value of the parameter $kl_0[band]$ is defined per upstream band. The values of kl_0 shall be formatted as shown in Table 12-29. If defined with a valid value, this parameter overrides "Final Electrical Length".

Table 12-29 – UPBOXFEL descriptor

Octet	Content of field
1	Number of US bands (n_{us})
2-3	bits 0-15: value of $kl_0[US1]$ for US1
4-5 (if applicable)	bits 0-15: value of $kl_0[US2]$ for US2
...	
$2 \times n_{us}, 2 \times n_{us} + 1$	bits 0-15: value of $kl_0[US(n_{us})]$ for US(n_{us})

12.3.3.2.1.3 O-PRM

O-PRM contains the downstream MEDLEY reference PSD following the modifications proposed in the R-UPDATE message. It also contains the modulation parameters that shall be used in the downstream direction from the beginning of the Training phase and requests for the durations of training periods in the Training phase. The full list of parameters carried by the O-PRM message is shown in Table 12-30.

Table 12-30 – Description of message O-PRM

	Field name	Format
1	Message descriptor	Message code
2	Downstream MEDLEY reference PSD (MREFPSDds)	PSD descriptor
3	MEDLEYds set	Bands descriptor
4	Cyclic extension length	1 byte
5	Downstream cyclic prefix length	2 bytes
6	Downstream transmit window length (β_{ds})	1 byte
7	VTU-O IDFT size	1 byte
8	Duration of the VTU-O EC training period	1 byte
9	Requested duration of the VTU-O TEQ training period	1 byte
10	Requested duration of the VTU-R TEQ training period	1 byte
11	Requested minimum duration of the periodic signal	1 byte
12	Downstream frequency-domain spectrum shaping	Log _{tss_i} descriptor
13	ITU-T G.998.4 parameter field	Variable length
14	ITU-T G.993.5 parameter field	Variable length

Field #1 "Message descriptor" is a one-byte code that identifies the message. See Table 12-6 for a complete list of codes.

Field #2 "Downstream MEDLEY reference PSD (MREFPSDds)" indicates the updated PSD at the U interface, following the request from the VTU-R in R-UPDATE. This PSD shall be used in the downstream direction starting from the beginning of the training phase and for the remainder of initialization. The "PSD descriptor" format specified in Table 12-23 shall be used, and the number of subcarriers being described shall be limited to ≤ 48 . The only valid PSD values obtained by the receiver using the interpolation procedure specified are those for subcarriers that belong to the MEDLEYds set (communicated in Field #3 of O-PRM), excluding the RFI bands communicated during the ITU-T G.994.1 handshake phase. PSD values out of this set shall be ignored by the VTU-R. The values of MREFPSDds shall be at least 3.5 dB below the downstream MEDLEY reference PSD mask (MREFMASKds, see clause 7.2.1), which, excluding the RFI bands, is the minimum of the transmit PSD mask (PSDMASKds, Field #4 of O-SIGNATURE), and the downstream PSD ceiling determined by the VTU-O. Moreover, the valid values of MREFPSDds, either those that are directly communicated or those obtained at the receiver by interpolation, shall not deviate from the downstream transmit PSD, as measured in the reference impedance at the U interface, by more than 1 dB.

Field #3 "MEDLEYds set" contains the MEDLEY set of subcarriers in the downstream direction. The MEDLEYds subcarriers shall be used starting from the beginning of the training phase. The "bands descriptor" format described in Table 12-22 shall be used. No more than 32 bands shall be specified.

Field #4 "Cyclic extension length" contains the value of L_{CE} that shall be used starting from the beginning of the training phase. This value may be different from the initial value that was exchanged during the ITU-T G.994.1 handshake phase if the VTUs have indicated that they support a change in CE length. The CE length shall be expressed as $L_{CE} = m \times N/32$. This field shall encode the value of m as an 8-bit value with valid values from 2 to 16.

NOTE – The duration of the CE is the same in the upstream and downstream directions. If the IDFT sizes used for both directions are the same, then the number of samples in the CE is also the same. If the IDFT sizes are

not the same, then the number of samples in the CE in the downstream and upstream directions will differ but can be easily derived using the value of m provided by the VTU-O.

Field #5 "Downstream cyclic prefix length" contains the value of L_{CP} that shall be applied in the downstream direction starting from the beginning of the training phase. The value shall be expressed in samples of the downstream sampling rate corresponding to the IDFT size communicated in Field #7. The format shall be the same as for Field #14 of the O-SIGNATURE message (Table 12-21).

Field #6 "Downstream transmit window length (β_{ds})" contains the length of the transmit window that shall be used in the downstream direction starting from the beginning of the training phase. The value shall be expressed in samples of the downstream sampling rate corresponding to the IDFT size communicated in Field #7. The format shall be the same as for Field #13 of the O-SIGNATURE message (Table 12-21).

Field #7 "VTU-O IDFT size" indicates the updated size of the IDFT at the VTU-O that shall be used in the downstream direction starting from the beginning of the training phase. This value may be different from the initial value that was exchanged during the ITU-T G.994.1 handshake phase. The value shall be expressed as the IDFT size $2N_{ds}$. The format shall be an 8-bit field coded as $\log_2(2N_{ds})$ with valid values from 7 to 13.

Field #8 "Duration of VTU-O EC training period" indicates the duration of the EC training signal the VTU-O shall transmit, expressed in DMT symbols. It shall be an integer multiple of 64 in the range from 0 to 1024. The duration divided by 64 shall be encoded as an 8-bit value.

Field #9 "Requested duration of the VTU-O TEQ training period" indicates the minimum duration of the VTU-O TEQ training period that the VTU-O requests, expressed in DMT symbols. It shall be an integer multiple of 64 in the range from 0 to 16320. The duration divided by 64 shall be encoded as an 8-bit value.

Field #10 "Requested duration of the VTU-R TEQ training period" indicates the minimum duration of the VTU-R TEQ training period that the VTU-O requests, expressed in DMT symbols. It shall be an integer multiple of 64 in the range from 0 to 16320. The duration divided by 64 shall be encoded as an 8-bit value.

Field #11 "Requested minimum duration of the periodic signal" indicates the minimum duration of the R-P-PERIODIC 2 signal that the VTU-O requests, expressed in DMT symbols. It shall be an integer multiple of 64 in the range from 0 to 2048. The duration divided by 64 shall be encoded as an 8-bit value.

Field #12 "Downstream frequency-domain spectrum shaping" indicates the tss_i values used by the VTU-O. The field shall be formatted as a "Log_ tss_i descriptor", shown in Table 12-31, with a maximum number of 64 breakpoints.

Table 12-31 – Log_ tss_i descriptor

Octet	Content of field
1	Number of breakpoints (subcarriers) to be described
2-4	Bits 0-11: Subcarrier index of the first breakpoint Bits 12-23: \log_{tss_i} value of the first breakpoint in steps of 0.1 dB
5-7 (if applicable)	Bits 0-11: Subcarrier index of the second breakpoint Bits 12-23: \log_{tss_i} value of the second breakpoint in steps of 0.1 dB
etc.	etc.

The first octet of the descriptor shall contain the number of breakpoints being specified. This number can be zero. In that case, there shall be no further octets in the descriptor, and the field shall be interpreted as all $\log_{tss_i} = 0$ for all transmitted subcarriers. If the number of breakpoints is not equal

to zero, each group of three consecutive octets shall describe one breakpoint as a \log_{tss_i} value (see clause 10.3.4.3) at a certain subcarrier index. The tss_i values shall be determined by the transmitter such that, with combined frequency domain and time domain spectrum shaping, the downstream PSD at the U interface during the training phase and subsequent initialization phases shall be identical to the value MREFPSDs.

The first 12 bits (0-11) in the group of three octets shall contain the index of the subcarrier. The last 12 bits (12-23) shall contain the \log_{tss_i} value of the subcarrier in dB calculated as specified in clause 10.3.4.3, such that the maximum \log_{tss_i} value across all breakpoints shall be 0 dB. Each \log_{tss_i} value shall be an integer multiple of -0.1 dB. The receiver shall obtain the \log_{tss_i} values for unspecified subcarriers using a linear interpolation between the \log_{tss_i} values of the assigned breakpoints as specified in clause 10.3.4.3.

The VTU-O shall provide non-zero tss_i values for all out-of-band subcarriers with indices from 1 to $t_{DS1_stop} + 32$, where t_{DS1_stop} is the highest-index subcarrier in DS1. The out-of-band tss_i values shall only be used during O-P-TEQ, as described in clause 12.3.4.3.1.4. The out-of-band tss_i values shall be set to ensure that the PSD of O-P-TEQ at the U interface is close to, but below, the relevant stopband limit PSD mask.

Field #13 is a variable length field consisting of an integer number of bytes. It is formatted as shown in Table 12-26.

Field #14 is a variable length field consisting of an integer number of bytes. It is formatted as shown in Table 12-26.

The actual data in the variable length fields 13 and 14 are beyond the scope of this Recommendation. For a correct interpretation at the receiver, support of either [ITU-T G.998.4] or [ITU-T G.993.5] or both is required. However, support of those Recommendations is not implied or required for compliance with Recommendation ITU-T G.993.2.

If the VTU-O does not support [ITU-T G.998.4], the ITU-T G.998.4 parameter field shall be a single byte with value 0.

If the VTU-O does not support [ITU-T G.993.5], the ITU-T G.993.5 parameter field shall be a single byte with value 0.

12.3.3.2.1.4 O-ACK

O-ACK is a one-byte message that acknowledges correct reception of the R-PRM message. The format of the message shall be as specified in clause 12.2.1, and the payload shall be as specified in Table 12-6.

12.3.3.2.2 VTU-R messages sent during the channel discovery phase

12.3.3.2.2.1 R-MSG 1

The full list of parameters carried by the R-MSG 1 message is shown in Table 12-32.

Table 12-32 – Description of message R-MSG 1

	Field name	Format
1	Message descriptor	Message code
2	Estimate of electrical length	2 bytes
3	Initial upstream PSD ceiling (CDMAXMASKus)	2 bytes
4	Channel Discovery upstream PSD (CDPSDus)	PSD descriptor
5	Initialization pilot tones	Tone descriptor
6	Timing advance	2 bytes

Table 12-32 – Description of message R-MSG 1

	Field name	Format
7	O-P-PILOT settings	1 byte
8	Upstream transmit window length (β_{us})	1 byte
9	Upstream cyclic prefix length	2 bytes
10	ITU-T G.998.4 parameter field	Variable length
11	ITU-T G.993.5 parameter field	Variable length
12	Extended estimate of electrical length	UPBOXEEL descriptor

Field #1 "Message descriptor" is a unique one-byte code that identifies the message. See Table 12-6 for a complete list of codes.

Field #2 "Estimate of electrical length" shall convey the estimate of the electrical length, expressed in dB at 1 MHz (see clause 7.2.1.3.2), as determined by the VTU-R. The value shall be coded as a 16-bit number. The value of the electrical length is obtained by multiplying this 16-bit value by 0.1 dB. The valid range of the electrical length is from 0 dB to 128 dB in 0.1 dB steps. Using this estimate of the electrical length, the VTU-R shall derive the upstream power back-off (UPBO) as described in clause 7.2.1.3. When using the alternative electrical length estimation method (ELE-M1) this parameter contains the value ELEDS.

Field #3 "Initial upstream PSD ceiling (CDMAXMASK_{us})" indicates the PSD level that is used to impose a ceiling on the upstream transmit PSD mask (after UPBO is performed) to form the upstream PSD mask for the signals transmitted during the channel discovery phase. The upstream channel discovery PSD (CDPSD_{us}, see Field #4) is derived using the value of CDMAXMASK_{us}. This field shall be coded the same as Field #7 of O-SIGNATURE.

Field #4 "Channel discovery upstream PSD (CDPSD_{us})" indicates the PSD at the U interface transmitted in the upstream direction during the channel discovery phase. The "PSD descriptor" format specified in Table 12-23 shall be used, and the number of subcarriers being described shall be limited to ≤ 32 . The only valid PSD values obtained by the receiver using the interpolation procedure specified are those for subcarriers that belong to the SUPPORTEDCARRIERS_{us} set, excluding the RFI bands communicated during the ITU-T G.994.1 handshake phase. PSD values out of this set shall be ignored by the receiver. The CDPSD_{us} values shall be at least 3.5 dB below the upstream transmit PSD mask (Field #5 of O-SIGNATURE), and at least 3.5 dB below the initial upstream PSD ceiling (Field #3 of R-MSG 1), and at least 3.5 dB below the UPBOMASK that corresponds to the electrical length value defined in Field #2. Moreover, the valid values of CDPSD_{us}, either those which are directly communicated or those obtained at the receiver by interpolation, shall not deviate from the actual value of the transmit PSD, as measured in the reference impedance at the U interface, by more than 1 dB.

Field #5 "Initialization pilot tones" indicates the selection of pilot tones by the VTU-R for timing recovery during the O-P-PILOT 1, O-P-PILOT 2, O-P-PILOT 3 and O-P-ECT stages. This information shall be used by the VTU-O during the lineprobe stage (if selected), and during the TEQ and echo canceller training stages of the training phase. The field shall be formatted as shown in Table 12-33. The total number of initialization pilot tones shall not exceed 16.

Table 12-33 – Tone descriptor

Octet	Content of field
1	Number of tones
2-4	Bits 0-11: index of tone 1 Bits 12-23: index of tone 2
5-7 (if applicable)	Bits 0-11: index of tone 3 Bits 12-23: index of tone 4
etc.	etc.

The first octet of the tone descriptor shall contain the number of pilot tones selected by the VTU-R. If this number is zero, there shall be no further octets in the descriptor. If the number of tones is not equal to zero, each group of three consecutive octets in the descriptor shall describe the location of two pilot tones.

The first 12 bits (0-11) and the last 12 bits (12-23) in each group of three octets shall contain the indices of two tones. For example, a field value 400200_{16} means tone $200_{16} = 512$ and tone $400_{16} = 1024$. If the number of pilot tones is odd, the last 12 bits in the field shall be set to ZERO.

Field #6 "Timing advance" indicates the timing advance selected by the VTU-R (which is either the initial value conveyed by the O-SIGNATURE message or a vendor-discretionary setting if no initial value was set by the VTU-O). It shall be expressed in samples at the upstream sampling rate corresponding to the IDFT size communicated during the ITU-T G.994.1 handshake phase. The value shall be encoded in a 16-bit field using twos complement format.

Field #7 "O-P-PILOT settings" indicates the setting of pilot tone power in O-P-PILOT signals during various stages. The format is one byte with the following encoding:

- the first MSB indicates whether the selected pilot tone(s) shall be allocated power in O-P-PILOT 1 during the channel discovery phase (1=ON, 0=OFF);
- the second and third MSBS indicate, respectively, whether the selected pilot tone(s) shall be allocated power in O-P-PILOT 2 and O-P-PILOT 3 during the training phase (1=ON, 0=OFF);
- other bits shall be set to ZERO.

Field #8 "Upstream transmit window length (β_{us})" contains the length of the transmit window that shall be used in the upstream direction during the channel discovery phase. The value shall be expressed in the samples of the upstream sampling rate corresponding to the IDFT size communicated during the ITU-T G.994.1 handshake phase. The format shall be the same as for Field #13 of the O-SIGNATURE message (Table 12-21).

Field #9 "Upstream cyclic prefix length" contains the length of the upstream cyclic prefix expressed in samples of the upstream sampling rate corresponding to the IDFT size communicated during the ITU-T G.994.1 handshake phase. The value shall be coded as a 16-bit unsigned integer.

Field #10 is a variable length field consisting of an integer number of bytes. It is formatted as shown in Table 12-26.

Field #11 is a variable length field consisting of an integer number of bytes. It is formatted as shown in Table 12-26.

The actual data in the variable length fields 10 and 11 are beyond the scope of this Recommendation. For a correct interpretation at the receiver, support of either [ITU-T G.998.4] or [ITU-T G.993.5] or both is required. However, support of those Recommendations is not implied or required for compliance with Recommendation ITU-T G.993.2.

If the VTU-R does not support [ITU-T G.998.4], the ITU-T G.998.4 parameter field shall be a single byte with value 0.

If the VTU-R does not support [ITU-T G.993.5], the ITU-T G.993.5 parameter field shall be a single byte with value 0.

Field #12 "Extended estimated electrical length" contains the estimated electrical length. The UPBOXEEL descriptor has the parameter $ELE[band]$ in dB for each downstream band (see Table 12-34, with the parameter specified in clause 7.2.1.3.2.1.2). The value shall be coded as a 16-bit number with the LSB weight of 0.1 dB. The valid range of values is from 0 dB to 128 dB with a 0.1 dB step.

Table 12-34 – UPBOXEEL descriptor

Octet	Content of field
1	Number of DS bands (n_{ds})
2-3	bits 0-15: value of $ELE[DS1]$
4-5 (if applicable)	bits 0-15: value of $ELE[DS2]$
...	
$2 \times n_{ds}, 2 \times n_{ds} + 1$	bits 0-15: value of $ELE[DS(n_{ds})]$

12.3.3.2.2.2 R-UPDATE

The R-UPDATE message is a request to modify the downstream PSD. The full list of parameters carried by the R-UPDATE message is shown in Table 12-35.

Table 12-35 – Description of message R-UPDATE

	Field name	Format
1	Message descriptor	Message code
2	Updated downstream PSD ceiling (MAXMASKds)	2 bytes
3	Proposed highest downstream subcarrier	2 bytes
4	Proposed lowest downstream subcarrier	2 bytes
5	BLACKOUTds set	Bands descriptor
6	Suggested cyclic extension length	1 byte
7	ITU-T G.998.4 parameter field	Variable length
8	ITU-T G.993.5 parameter field	Variable length

Field #1 "Message descriptor" is a unique one-byte code that identifies the message. See Table 12-6 for a complete list of codes.

Field #2 "Updated downstream PSD ceiling (MAXMASKds)" indicates the PSD ceiling level of the downstream transmit PSD mask. This field shall be coded the same as Field #7 of O-SIGNATURE. If this level is lower than the downstream PSD ceiling indicated in O-SIGNATURE, the VTU-O shall apply this new ceiling level to PSDMASKds. Otherwise, the VTU-O may increase the ceiling of the downstream PSD mask up to MAXMASKds. This new ceiling level shall be used to form the downstream MEDLEY reference PSD mask (MREFMASKds). A special value 1000_{16} shall indicate that there is no limit on the downstream PSD ceiling level (under the constraints of the downstream transmit PSD mask).

Field #3 "Proposed highest downstream subcarrier" contains an estimate by the VTU-R of the highest-index downstream subcarrier that can be loaded with data bits. The format shall be the same

as for Field #4 of the O-UPDATE message. The VTU-O may transmit subcarriers with indices higher than this value, as long as those subcarriers are in the SUPPORTEDCARRIERS_{ds} set.

Field #4 "Proposed lowest downstream subcarrier" contains an estimate by the VTU-R of the lowest-index downstream subcarrier that can be loaded with data bits. The format shall be the same as for Field #5 of the O-UPDATE message. The VTU-O may transmit subcarriers with indices lower than this value, as long as those subcarriers are in the SUPPORTEDCARRIERS_{us} set.

Field #5 "BLACKOUT_{ds} set" contains the BLACKOUT set of subcarriers in the downstream direction. The field shall be formatted as a "bands descriptor" (see Table 12-22), with a maximum number of 16 bands. If there are no blackout subcarriers, the field shall consist of one octet, 00₁₆.

Field #6 "Suggested cyclic extension length" contains the value of the CE length suggested by the VTU-R. This value may be different from the initial value exchanged during the ITU-T G.994.1 handshake phase if both VTUs support a change in CE length. The final CE length shall be decided by the VTU-O (see O-PRM message in clause 12.3.3.2.1.3). The format shall be the same as for Field #4 of the O-PRM message (Table 12-30).

Field #7 is a variable length field consisting of an integer number of bytes. It is formatted as shown in Table 12-26.

Field #8 is a variable length field consisting of an integer number of bytes. It is formatted as shown in Table 12-26.

The actual data in the variable length fields 7 and 8 are beyond the scope of this Recommendation. For a correct interpretation at the receiver, support of either [ITU-T G.998.4] or [ITU-T G.993.5] or both is required. However, support of those Recommendations is not implied or required for compliance with Recommendation ITU-T G.993.2.

If the VTU-R does not support [ITU-T G.998.4], the ITU-T G.998.4 parameter field shall be a single byte with value 0.

If the VTU-R does not support [ITU-T G.993.5], the ITU-T G.993.5 parameter field shall be a single byte with value 0.

12.3.3.2.2.3 R-PRM

The R-PRM message is sent in response to the O-PRM message. It contains the upstream MEDLEY reference PSD following the modifications proposed in the O-UPDATE message. It also contains the modulation parameters that shall be used in the upstream direction from the beginning of the training phase and requests for the durations of training periods in the training phase. The full list of parameters carried by the R-PRM message is shown in Table 12-36.

Table 12-36 – Description of message R-PRM

	Field name	Format
1	Message descriptor	Message code
2	Upstream MEDLEY reference PSD (MREFPSD _{us})	PSD descriptor
3	MEDLEY _{us} set	Bands descriptor
4	Upstream cyclic prefix length	2 bytes
5	Upstream transmit window length (β_{us})	1 byte
6	VTU-R IDFT size	1 byte
7	Duration of the VTU-R EC training period	1 byte
8	Requested duration of the VTU-R TEQ training period	1 byte

Table 12-36 – Description of message R-PRM

	Field name	Format
9	Requested duration of the VTU-O TEQ training period	1 byte
10	Requested minimum duration of the periodic signal	1 byte
11	Minimum duration of the R-P-TRAINING 1 signal ($T_{\text{MIN-R-P-Train}}$)	1 byte
12	Upstream frequency-domain spectrum shaping	Log _{tss_i} descriptor
13	ITU-T G.998.4 parameter field	Variable length
14	ITU-T G.993.5 parameter field	Variable length

Field #1 "Message descriptor" is a one-byte code that identifies the message. See Table 12-6 for a complete list of codes.

Field #2 "Upstream MEDLEY reference PSD (MREFPSD_{us})" indicates the updated PSD at the U interface following the request from the VTU-O in O-UPDATE. This PSD shall be used in the upstream direction from the beginning of the training phase and for the remainder of initialization. The "PSD descriptor" format specified in Table 12-23 shall be used, and the number of subcarriers being described shall be limited to ≤ 32 . The only valid PSD values obtained by the receiver using the interpolation procedure specified are those for the subcarriers that belong to the MEDLEY_{us} set (communicated in Field #3), excluding the RFI bands communicated during the ITU-T G.994.1 handshake phase. PSD values out of this set shall be ignored by the VTU-O. The values of MREFPSD_{us} shall be at least 3.5 dB below the upstream MEDLEY reference PSD mask (MREFMASK_{us}, see clause 7.2.1) which, excluding the RFI bands, is the minimum of the transmit PSD mask (PSDMASK_{us}, Field #5 of O-SIGNATURE), the UPBOMASK determined by the VTU-R (which corresponds to the electrical length value defined in Field #2 of O-UPDATE), and the upstream PSD ceiling determined by the VTU-R. Moreover, the valid values of MREFPSD_{us}, either those that are directly communicated or those obtained at the receiver by interpolation, shall not deviate from the upstream transmit PSD, as measured in the reference impedance at the U interface, by more than 1 dB.

Field #3 "MEDLEY_{us} set" contains the MEDLEY set of subcarriers in the upstream direction. The MEDLEY_{us} subcarriers shall be used starting from the beginning of the training phase. The "bands descriptor" format described in Table 12-22 shall be used. No more than 32 bands shall be specified.

Field #4 "Upstream cyclic prefix length" contains the value of the cyclic prefix that shall be applied in the upstream direction starting from the beginning of the training phase. The value shall be expressed in samples of the upstream sampling rate corresponding to the IDFT size communicated in Field #6. The format of the selected cyclic prefix length shall be the same as for Field #14 of the O-SIGNATURE message (Table 12-21).

NOTE – The value of the CE length used in the calculation of the upstream cyclic prefix length is the value communicated in O-PRM, not the one sent in R-UPDATE.

Field #5 "Upstream transmit window length (β_{us})" contains the length of the transmit window that shall be used in the upstream direction starting from the beginning of the training phase. The value shall be expressed in samples of the upstream sampling rate corresponding to the IDFT size communicated in Field #6. The format shall be the same as for Field #13 of the O-SIGNATURE message (Table 12-21).

Field #6 "VTU-R IDFT size" communicates the IDFT size, $2N_{us}$, that shall be used by the VTU-R starting from the beginning of the training phase. The format shall be an 8-bit field coded as $\log_2(2N_{us})$, with valid values from 6 to 13. This value may be different from the initial value that was exchanged during the ITU-T G.994.1 handshake phase.

Field #7 "Duration of VTU-R EC training period" indicates the duration of the VTU-R EC training signal that the VTU-R shall transmit, expressed in DMT symbols. It shall be an integer multiple of 64 in the range from 0 to 1024. The duration divided by 64 shall be encoded as an 8-bit value.

Field #8 "Requested duration of the VTU-R TEQ training period" indicates the minimum duration of the VTU-R TEQ training period that the VTU-R requests, expressed in DMT symbols. It shall be an integer multiple of 64 in the range from 0 to 16320. The duration divided by 64 shall be encoded as an 8-bit value.

Field #9 "Requested duration of the VTU-O TEQ training period" indicates the minimum duration of the VTU-O TEQ training period that the VTU-R requests, expressed in DMT symbols. It shall be an integer multiple of 64 in the range from 0 to 16320. The duration divided by 64 shall be encoded as an 8-bit value.

Field #10 "Requested minimum duration of the periodic signal" indicates the minimum duration of the O-P-PERIODIC 2 signal the VTU-R requests, expressed in DMT symbols. It shall be an integer multiple of 64 in the range from 0 to 2048. The duration divided by 64 shall be encoded as an 8-bit value.

Field #11 "Minimum duration of the R-P-TRAINING 1 signal ($T_{\text{MIN-R-P-Train}}$)" indicates the minimum duration of the R-P-TRAINING 1 signal that the VTU-R shall transmit. The value, $T_{\text{MIN-R-P-Train}}$, shall be expressed in DMT symbols. The duration shall be an integer multiple of 64 symbols. The integer multiple (i.e., the duration divided by 64) shall be encoded as an 8-bit value.

Field #12: "Upstream frequency-domain spectrum shaping" indicates the updated tss_i values used by the VTU-R. The field shall be formatted as a "Log_ tss_i descriptor" as shown in Table 12-31.

The VTU-R shall provide non-zero tss_i values for all out-of-band subcarriers with indices from 1 to $t_{\text{USO_stop}} + 32$, where $t_{\text{USO_stop}}$ is the highest-index subcarrier in US0. The out-of-band tss_i values (virtual values, since no out-of-band subcarriers are transmitted during channel discovery) shall only be used during R-P-TEQ, as described in clause 12.3.4.3.2.4. The out-of-band tss_i values shall be set to ensure that the PSD of R-P-TEQ at the U interface is close to, but below, the relevant stopband Limit PSD mask.

Field #13 is a variable length field consisting of an integer number of bytes. It is formatted as shown in Table 12-26.

Field #14 is a variable length field consisting of an integer number of bytes. It is formatted as shown in Table 12-26.

The actual data in the variable length fields 13 and 14 are beyond the scope of this Recommendation. For a correct interpretation at the receiver, support of either [ITU-T G.998.4] or [ITU-T G.993.5] or both is required. However, support of those Recommendations is not implied or required for compliance with Recommendation ITU-T G.993.2.

If the VTU-R does not support [ITU-T G.998.4], the ITU-T G.998.4 parameter field shall be a single byte with value 0.

If the VTU-R does not support [ITU-T G.993.5], the ITU-T G.993.5 parameter field shall be a single byte with value 0.

12.3.3.3 Signals transmitted during the channel discovery phase

All signals transmitted during the channel discovery phase shall use only subcarriers from the SUPPORTEDCARRIERSds set in the downstream direction and subcarriers from the SUPPORTEDCARRIERSus set in the upstream direction.

The transmit PSD of all downstream signals with non-zero output power shall comply with the downstream transmit PSD mask (PSDMASKds), in both the passband and the stopbands, capped at the level of the initial downstream PSD ceiling (Field #7 of O-SIGNATURE). The downstream PSD

shall not exceed -80 dBm/Hz in any RFI bands that were defined during the ITU-T G.994.1 handshake phase. The values of CE and $2N_{ds}$ shall be as defined during the ITU-T G.994.1 handshake phase. The values of β_{ds} and the cyclic prefix length shall be as communicated in Fields #13 and #14 of O-SIGNATURE, respectively.

The transmit PSD of all upstream signals with non-zero output power shall comply with the upstream transmit PSD mask (PSDMASK_{us}), in both the passband and the stopbands, capped at the level of the initial upstream PSD ceiling (Field #3 of R-MSG 1). The upstream PSD shall comply with UPBO requirements specified in clause 7.2.1.3 and shall not exceed -80 dBm/Hz in any RFI bands that were defined during the ITU-T G.994.1 handshake phase. The values of CE and $2N_{us}$ shall be as defined during the ITU-T G.994.1 handshake phase. The values of β_{us} and timing advance shall be as communicated in Field #8 and Field #6 of R-MSG 1, respectively. The cyclic prefix length shall be as communicated in Field #9 of R-MSG 1.

12.3.3.3.1 Signals transmitted by the VTU-O

12.3.3.3.1.1 O-P-QUIET 1

O-P-QUIET 1 shall provide a zero output voltage at the U reference point. All subcarriers shall be allocated zero power.

The duration of O-P-QUIET 1 is variable between 512 and 1 024 symbols. Its duration is at the discretion of the VTU-O.

12.3.3.3.1.2 O-P-CHANNEL DISCOVERY 1

O-P-CHANNEL DISCOVERY 1 is a signal that allows the VTU-R to synchronize and to measure the attenuation of the channel. During transmission of O-P-CHANNEL DISCOVERY 1, the SOC is in its active state.

The duration of O-P-CHANNEL DISCOVERY 1 is variable. O-P-CHANNEL DISCOVERY 1 is terminated by transmission of O-P-SYNCHRO 1.

O-P-CHANNEL DISCOVERY 1 shall be composed of all subcarriers in SUPPORTEDCARRIERS_{ds} modulated by 4-QAM. Each DMT symbol of O-P-CHANNEL DISCOVERY 1 shall carry one byte of information. The mapping of bits to subcarriers shall be as summarized in Table 12-37.

Table 12-37 – Bit mapping for O-P-CHANNEL DISCOVERY 1

Subcarrier index	Constellation point
Even	00
1, 11, 21, ..., $10n+1$, ...	SOC message bits 0 and 1
3, 13, 23, ..., $10n+3$, ...	SOC message bits 2 and 3
5, 15, 25, ..., $10n+5$, ...	SOC message bits 4 and 5
7, 17, 27, ..., $10n+7$, ...	SOC message bits 6 and 7
9, 19, 29, ..., $10n+9$, ...	00
NOTE – The byte is given as (b7, b6, b5, b4, b3, b2, b1, b0), where b7 is the MSB and b0 is the LSB. Mapping, e.g., "SOC message bits 0 and 1" to subcarriers $10n+1$ means that the two-bit value (b1,b0) shall be used to determine the constellation point in accordance with the encoding rules given in clause 10.3.3.2. This constellation point will then be scrambled using the quadrant scrambler described in clause 12.3.6.2.	

The constellation points on all subcarriers shall be rotated based on the 2-bit number provided by the quadrant scrambler described in clause 12.3.6.2. The scrambler shall be used in reset mode (see clause 12.3.6.2.1).

Symbols shall be generated as described in clause 10.4.4. The symbol length shall be $2N_{ds} + L_{CE}$ samples. The overall window length shall be equal to β_{ds} .

The transmit PSD of the subcarriers from the SUPPORTEDCARRIERSds set of the O-P-CHANNEL DISCOVERY 1 signal shall be equal to CDPSDs (communicated in Field #6 of O-SIGNATURE).

12.3.3.3.1.3 O-P-SYNCHRO 1

O-P-SYNCHRO 1 is a signal that provides an exact time marker for transitions from O-P-CHANNEL DISCOVERY 1 to either O-P-QUIET 2/O-P-PILOT 1 or O-P-PERIODIC 1. During transmission of O-P-SYNCHRO 1, the SOC is in its inactive state.

The duration of O-P-SYNCHRO 1 is 15 DMT symbols.

O-P-SYNCHRO 1 shall use all subcarriers in the SUPPORTEDCARRIERSds set modulated by 4-QAM. The value 11 shall be mapped to all of the SUPPORTEDCARRIERSds subcarriers for the first 5 and the last 5 DMT symbols. The value 00 shall be mapped to all SUPPORTEDCARRIERSds subcarriers for the middle 5 DMT symbols. The constellation points on all subcarriers shall be rotated based on the 2-bit number provided by the quadrant scrambler described in clause 12.3.6.2. The scrambler shall be used in reset mode (see clause 12.3.6.2.1).

Symbols shall be generated as described in clause 10.4.4. The symbol length shall be $2N_{ds}+L_{CE}$ samples. The overall window length shall be equal to β_{ds} .

The transmit PSD of the SUPPORTEDCARRIERSds subcarriers in O-P-SYNCHRO 1 shall be the same as for O-P-CHANNEL DISCOVERY 1.

12.3.3.3.1.4 O-P-PILOT 1

The O-P-PILOT 1 signal is intended to allow the VTU-R to maintain loop timing during the lineprobe stage. During the transmission of O-P-PILOT 1, the SOC is in its inactive state.

The duration of O-P-PILOT 1 is 640 DMT symbols with CE.

O-P-PILOT 1 consists only of the pilot tones that were chosen by the VTU-R and communicated to the VTU-O in Field #5 of R-MSG 1. A value of 00 shall be mapped to all pilot tones with 4-QAM modulation during every symbol of O-P-PILOT 1.

Symbols shall be generated as described in clause 10.4.4. The symbol length shall be $2N_{ds}+L_{CE}$ samples. The overall window length shall be equal to β_{ds} .

The transmit PSD of O-P-PILOT 1 shall comply with the downstream transmit PSD mask (PSDMASKds) capped at the level of the initial downstream PSD ceiling communicated in Field #7 of O-SIGNATURE. The transmit power of the pilot tones shall be set to 0 if the first MSB of the O-P-PILOT settings field of R-MSG 1 is set to ZERO.

12.3.3.3.1.5 O-P-QUIET 2

O-P-QUIET 2 is identical to O-P-QUIET 1 except that its duration shall be a fixed 640 DMT symbols with CE.

12.3.3.3.1.6 O-P-PERIODIC 1

O-P-PERIODIC 1 is a periodic signal intended to allow both VTUs to make accurate SNR measurements. During transmission of O-P-PERIODIC 1, the SOC is in its inactive state.

The duration of O-P-PERIODIC 1 shall be 2048 DMT symbols with CE.

O-P-PERIODIC 1 shall be composed of all subcarriers in the SUPPORTEDCARRIERSds set. These subcarriers shall be modulated by 4-QAM. The value 11 shall be mapped to all subcarriers in the SUPPORTEDCARRIERSds set. The constellation points on all subcarriers shall be rotated based on

the 2-bit number provided by the quadrant scrambler described in clause 12.3.6.2. The scrambler shall be used in reset mode (see clause 12.3.6.2.1).

O-P-PERIODIC 1 shall be constructed as described in clause 12.3.6.1.

The transmit PSD of the SUPPORTEDCARRIERSds subcarriers in O-P-PERIODIC 1 shall be the same as for O-P-CHANNEL DISCOVERY 1.

12.3.3.3.1.7 O-P-SYNCHRO 2

O-P-SYNCHRO 2 is a signal that provides an exact time marker for transitions from O-P-PERIODIC 1 to O-P-CHANNEL DISCOVERY 2. During transmission of O-P-SYNCHRO 2, the SOC is in its inactive state.

O-P-SYNCHRO 2 shall be identical to O-P-SYNCHRO 1.

12.3.3.3.1.8 O-P-CHANNEL DISCOVERY 2

O-P-CHANNEL DISCOVERY 2 allows the VTU-O to send updated modulation parameters as well as information needed for the training phase (such as signal durations). During transmission of O-P-CHANNEL DISCOVERY 2, the SOC is in its active state.

The duration of O-P-CHANNEL DISCOVERY 2 is variable. O-P-CHANNEL DISCOVERY 2 is terminated by the transmission of O-P-SYNCHRO 3.

The symbols of O-P-CHANNEL DISCOVERY 2 shall be constructed in the same manner as the symbols of O-P-CHANNEL DISCOVERY 1 (see clause 12.3.3.3.1.2).

The transmit PSD of the subcarriers from the SUPPORTEDCARRIERSds set of the O-P-CHANNEL DISCOVERY 2 signal shall be equal to CDPSDs (communicated in Field #6 of O-SIGNATURE).

12.3.3.3.1.9 O-P-SYNCHRO 3

O-P-SYNCHRO 3 is a signal that provides an exact time marker for transitions from O-P-CHANNEL DISCOVERY 2 to O-P-TRAINING 1 (Training phase).

O-P-SYNCHRO 3 shall be identical to O-P-SYNCHRO 1.

12.3.3.3.2 Signals transmitted by the VTU-R

12.3.3.3.2.1 R-P-QUIET 1

R-P-QUIET 1 shall provide a zero output voltage at the U reference point. All subcarriers shall be allocated zero power. The duration of R-P-QUIET 1 is variable. Its duration is at the discretion of the VTU-R.

12.3.3.3.2.2 R-P-CHANNEL DISCOVERY 1

R-P-CHANNEL DISCOVERY 1 is a signal used by the VTU-R to send information about the upstream PSD, timing advance, and its selection of pilot tones (if any). During transmission of R-P-CHANNEL DISCOVERY 1, the SOC is in its active state.

The duration of R-P-CHANNEL DISCOVERY 1 is variable. R-P-CHANNEL DISCOVERY 1 is terminated by transmission of R-P-SYNCHRO 1.

R-P-CHANNEL DISCOVERY 1 shall be composed of all subcarriers in SUPPORTEDCARRIERSus modulated by 4-QAM. Each DMT symbol of R-P-CHANNEL DISCOVERY 1 shall carry one byte of information. The mapping of bits to subcarriers is summarized in Table 12-38.

Table 12-38 – Bit mapping for R-P-CHANNEL DISCOVERY 1

Subcarrier index	Constellation point
Even	00
1, 11, 21, ..., $10n+1$, ...	SOC message bits 0 and 1
3, 13, 23, ..., $10n+3$, ...	SOC message bits 2 and 3
5, 15, 25, ..., $10n+5$, ...	SOC message bits 4 and 5
7, 17, 27, ..., $10n+7$, ...	SOC message bits 6 and 7
9, 19, 29, ..., $10n+9$, ...	00
NOTE – The byte is given as (b7, b6, b5, b4, b3, b2, b1, b0), where b7 is the MSB and b0 is the LSB. Mapping, e.g., "SOC message bits 0 and 1" to subcarriers $10n+1$ means that the two-bit value (b1,b0) shall be used to determine the constellation point in accordance with the encoding rules given in clause 10.3.3.2. This constellation point will then be scrambled using the quadrant scrambler described in clause 12.3.6.2.	

The constellation points of all subcarriers shall be rotated based on the 2-bit number provided by the quadrant scrambler described in clause 12.3.6.2. The scrambler shall be used in reset mode (see clause 12.3.6.2.1).

Symbols shall be generated as described in clause 10.4.4. The symbol length shall be $2N_{us} + L_{CE}$ samples. The overall window length shall be equal to β_{us} .

The transmit PSD of the subcarriers from the SUPPORTEDCARRIERS_{us} set of the R-P-CHANNEL DISCOVERY 1 signal shall be equal to CDPSD_{us} (communicated in Field #4 of R-MSG 1).

12.3.3.3.2.3 R-P-SYNCHRO 1

R-P-SYNCHRO 1 is a signal that provides an exact time marker for transitions from R-P-CHANNEL DISCOVERY 1 to R-P-PERIODIC 1 or R-P-LINEPROBE if requested during the G.994.1 handshake phase. During transmission of R-P-SYNCHRO 1, the SOC is in its inactive state.

The duration of R-P-SYNCHRO 1 is 15 DMT symbols.

R-P-SYNCHRO 1 shall use all subcarriers in the SUPPORTEDCARRIERS_{us} set modulated by 4-QAM. The value 11 shall be mapped to all SUPPORTEDCARRIERS_{us} subcarriers for the first 5 and the last 5 DMT symbols. The value 00 shall be mapped to all of the SUPPORTEDCARRIERS_{us} subcarriers for the middle 5 DMT symbols. The constellation points on all subcarriers shall be rotated based on the 2-bit number provided by the quadrant scrambler described in clause 12.3.6.2. The scrambler shall be used in reset mode (see clause 12.3.6.2.1).

Symbols shall be generated as described in clause 10.4.4. The symbol length shall be $2N_{us} + L_{CE}$ samples. The overall window length shall be equal to β_{us} .

The transmit PSD of the SUPPORTEDCARRIERS_{us} subcarriers in R-P-SYNCHRO 1 shall be the same as for R-P-CHANNEL DISCOVERY 1.

12.3.3.3.2.4 R-P-LINEPROBE

R-P-LINEPROBE is a vendor-discretionary signal that allows the VTU-R to perform line probing. During transmission of R-P-LINEPROBE, the SOC is in its inactive state.

The duration of R-P-LINEPROBE is 512 DMT symbols with CE.

The transmit PSD of R-P-LINEPROBE shall respect PSDMASK_{us}, in both the passband and the stopbands, capped at the level of the initial upstream PSD ceiling (Field #3 of R-MSG 1). The PSD of R-P-LINEPROBE shall comply with UPBO requirements specified in clause 7.2.1.3 and shall not exceed -80 dBm/Hz in any RFI bands that were defined during the ITU-T G.994.1 handshake phase.

12.3.3.3.2.5 R-P-PERIODIC 1

R-P-PERIODIC 1 is a periodic signal intended to allow both VTUs to make accurate SNR measurements. During transmission of R-P-PERIODIC 1, the SOC is in its inactive state.

The duration of R-P-PERIODIC shall be 2048 DMT symbols with CE.

R-P-PERIODIC 1 shall be composed of all subcarriers in the SUPPORTEDCARRIERS_{SUS} set. These subcarriers shall be modulated by 4-QAM. The value 11 shall be mapped to all subcarriers in the SUPPORTEDCARRIERS_{SUS} set. The constellation points on all subcarriers shall be rotated based on the 2-bit number provided by the quadrant scrambler described in clause 12.3.6.2. The scrambler shall be used in reset mode (see clause 12.3.6.2.1).

R-P-PERIODIC 1 shall be constructed as described in clause 12.3.6.1.

The transmit PSD of the SUPPORTEDCARRIERS_{SUS} subcarriers in R-P-PERIODIC 1 shall be the same as for R-P-CHANNEL DISCOVERY 1.

12.3.3.3.2.6 R-P-SYNCHRO 2

R-P-SYNCHRO 2 is a signal that provides an exact time marker for transitions from R-P-PERIODIC 1 to R-P-CHANNEL DISCOVERY 2. During transmission of R-P-SYNCHRO 2, the SOC is in its inactive state.

R-P-SYNCHRO 2 shall be identical to R-P-SYNCHRO 1.

12.3.3.3.2.7 R-P-CHANNEL DISCOVERY 2

R-P-CHANNEL DISCOVERY 2 allows the VTU-R to request modifications to the downstream transmit signal, to send updated modulation parameters, and to send information needed for the training phase (such as signal durations). During transmission of R-P-CHANNEL DISCOVERY 2, the SOC is in its active state.

The duration of R-P-CHANNEL DISCOVERY 2 is variable. R-P-CHANNEL DISCOVERY 2 is terminated by the transmission of R-P-SYNCHRO 3.

The symbols of R-P-CHANNEL DISCOVERY 2 shall be constructed in the same manner as the symbols of R-P-CHANNEL DISCOVERY 1 (see clause 12.3.3.3.2.2).

The transmit PSD of the subcarriers from the SUPPORTEDCARRIERS_{SUS} set of the R-P-CHANNEL DISCOVERY 2 signal shall be equal to CDPSD_{SUS} (communicated in Field #4 of R-MSG 1).

12.3.3.3.2.8 R-P-SYNCHRO 3

R-P-SYNCHRO 3 is a signal that provides an exact time marker for transitions from R-P-CHANNEL DISCOVERY 2 to R-P-QUIET 2 (training phase).

R-P-SYNCHRO 3 shall be identical to R-P-SYNCHRO 1.

12.3.4 Training phase

12.3.4.1 Overview

During the training phase, the VTUs may train their TEQ and echo canceller (EC). In the case that a TEQ or EC or both are not required, the corresponding stages may be shortened to accelerate completion of the initialization procedure. Also, the value of timing advance may be adjusted during this phase.

Figure 12-8 presents the timing diagram for the stages of the training phase. It gives an overview of the sequence of signals transmitted and SOC messages sent by the VTU-O and VTU-R during the training phase. The two inner columns show the sequences of signals that are transmitted (see clause 12.3.4.3). The two outer columns show the messages that are sent over the SOC (see clause 12.3.4.2). The shaded areas correspond to periods of time when the SOC is in its inactive state.

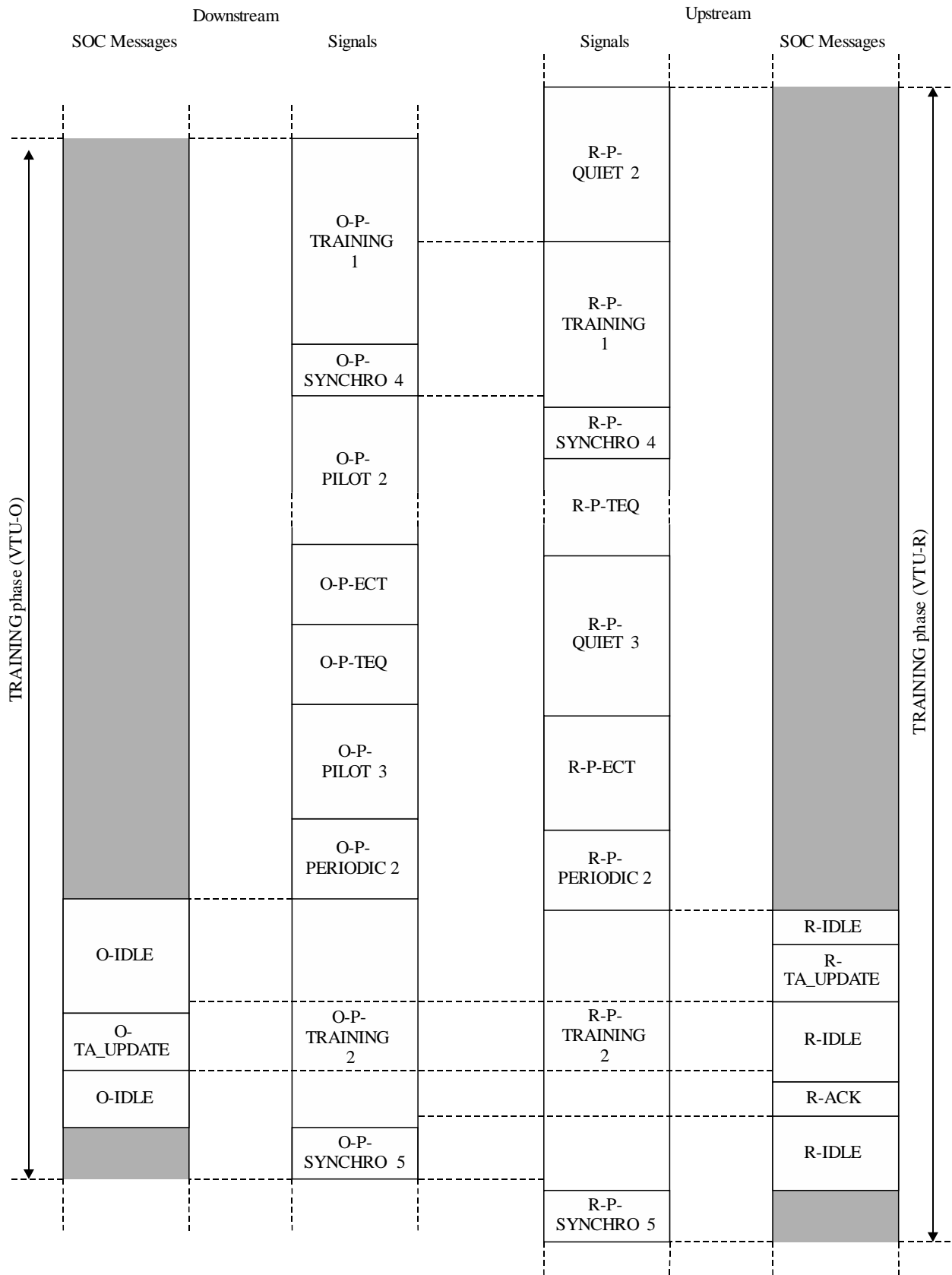

G.993.2(15)_F12-8

Figure 12-8 – Timing diagram for the stages of the training phase

NOTE 1 – In the exchange of the SOC messages identified in Figure 12-8, the rules of the communication protocol of clause 12.2.2 apply. Some messages sent in the SOC may require segmentation; although this is not shown in Figure 12-8, the segmented message elements and their corresponding acknowledgements are sent via the SOC per the communication protocol of clause 12.2.2.

At the start of the training phase, the VTU-O shall transmit O-P-TRAINING 1, and the VTU-R shall be silent (R-P-QUIET 2). This time may be used by the VTU-R to recover timing or symbol boundaries in case one or more of the modulation parameters (CE length, IDFT size, etc.) was changed at the completion of the channel discovery phase.

After not more than 4 096 symbols, the VTU-R shall transition from R-P-QUIET 2 to transmitting R-P-TRAINING 1. During the period that R-P-TRAINING 1 is transmitted, both VTUs can re-adjust their AGC settings to adapt to changes in the transmit PSD at the completion of the channel discovery phase. After the VTU-O receives at least $T_{\text{MIN-R-P-Train}}$ R-P-TRAINING 1 symbols (Field #11 of R-PRM, see clause 12.3.3.2.2.3), it shall transmit O-P-SYNCHRO 4 to indicate the start of the TEQ and EC training stages. After detecting O-P-SYNCHRO 4, the VTU-R shall respond within a time period between 48 and 64 symbols by transmitting R-P-SYNCHRO 4.

The durations of the TEQ training signals, the EC training signals, and the periodic signal transmitted after TEQ and EC training are determined from the values requested by the VTU-O and VTU-R during the channel discovery phase. They shall be defined as:

- $T_{\text{VTU-O_TEQ}}$: duration of the VTU-O TEQ training, equal to the greater of the values requested by the VTU-O in Field # 9 of O-PRM and by the VTU-R in Field #9 of R-PRM;
- $T_{\text{VTU-R_TEQ}}$: duration of the VTU-R TEQ training, equal to the greater of the values requested by the VTU-O in Field #10 of O-PRM and by the VTU-R in Field #8 of R-PRM;
- $T_{\text{VTU-O_EC}}$: duration of the VTU-O EC training, equal to the value communicated by the VTU-O in Field #8 of O-PRM;
- $T_{\text{VTU-R_EC}}$: duration of the VTU-R EC training, equal to the value communicated by the VTU-R in Field #7 of R-PRM; and
- T_{Periodic} : duration of the O-P-PERIODIC 2 and R-P-PERIODIC 2 signals following TEQ and EC training, equal to the greater of the values requested by the VTU-O in Field #11 of O-PRM and by the VTU-R in Field #10 of R-PRM.

The VTUs shall determine when to transition from one stage to the next by counting the number of symbols transmitted during each stage.

Immediately after transmission of O-P-SYNCHRO 4, the VTU-O shall transmit O-P-PILOT 2, and shall continue transmitting O-P-PILOT 2 for $T_{\text{VTU-O_TEQ}}$ symbols. Immediately after transmission of R-P-SYNCHRO 4, the VTU-R shall transmit R-P-TEQ for $T_{\text{VTU-O_TEQ}}$ symbols. During this stage, the VTU-O may train its TEQ.

NOTE 2 – It is expected that the timing recovery at the VTU-R will be stable during the last 512 symbols of R-P-TEQ transmission.

Immediately after all $T_{\text{VTU-O_TEQ}}$ symbols of O-P-PILOT 2 have been transmitted, the VTU-O shall transmit O-P-ECT for $T_{\text{VTU-O_EC}}$ symbols. During transmission of O-P-ECT, the VTU-O may train its echo canceller.

After all $T_{\text{VTU-O_EC}}$ symbols of O-P-ECT have been transmitted, the VTU-O shall transmit O-P-TEQ for $T_{\text{VTU-R_TEQ}}$ symbols. The VTU-R shall transmit $T_{\text{VTU-O_EC}} + T_{\text{VTU-R_TEQ}}$ symbols of R-P-QUIET 3 immediately after all $T_{\text{VTU-O_TEQ}}$ symbols of R-P-TEQ have been transmitted. During the transmission of O-P-TEQ, the VTU-R may train its TEQ.

Immediately after the VTU-O has transmitted all $T_{\text{VTU-R_TEQ}}$ symbols of O-P-TEQ, it shall transmit O-P-PILOT 3 for $T_{\text{VTU-R_EC}}$ symbols. After the VTU-R has transmitted all $T_{\text{VTU-O_EC}} + T_{\text{VTU-R_TEQ}}$ symbols of R-P-QUIET 3, it shall transmit R-P-ECT for $T_{\text{VTU-R_EC}}$ symbols. During this stage, the VTU-R may train its echo canceller.

After transmitting the last symbol of O-P-PILOT 3, the VTU-O shall transmit T_{Periodic} symbols of O-P-PERIODIC 2. After transmitting the last symbol of R-P-ECT, the VTU-R shall likewise transmit T_{Periodic} symbols of R-P-PERIODIC 2. During this stage, there is bidirectional transmission of periodic signals that may be used to make further adjustments to the TEQ at each receiver. After transmitting the last symbol of O-P-PERIODIC 2, the VTU-O shall transmit O-P-TRAINING 2. After transmitting the last symbol of R-P-PERIODIC 2, the VTU-R shall transmit R-P-TRAINING 2. At this point, the SOC shall be re-activated and the VTU-O shall send O-IDLE and the VTU-R shall send R-IDLE.

The VTU-R shall send R-IDLE for at least the first 128 symbols of R-P-TRAINING 2. The first message after that shall be R-TA_UPDATE. R-TA_UPDATE is used to communicate the current setting of the timing advance and to indicate the preferred and maximum values of the timing advance that the VTU-R can accommodate. The VTU-O shall acknowledge the reception of R-TA_UPDATE by sending O-TA_UPDATE containing the final value of the timing advance. The VTU-R shall acknowledge the reception of the O-TA_UPDATE message by sending R-ACK. The adjusted timing advance value shall be activated 5 symbols after the completion of R-ACK. The messages R-TA_UPDATE and O-TA_UPDATE also establish the number of SOC bytes per DMT symbol that will be used during the channel analysis and exchange phase.

To provide high robustness, both VTUs shall use the RQ protocol, as described in clause 12.2.2.2. Thus, the receiving VTU may ask for a retransmission of any message that was not correctly received.

After receiving R-ACK, the VTU-O shall continue to transmit O-P-TRAINING 2 for a duration of at least 64 symbols, and then shall indicate the end of the training phase by transmitting O-P-SYNCHRO 5. The VTU-R shall acknowledge the detection of O-P-SYNCHRO 5 by transmitting R-P-SYNCHRO 5 within a time period of 64 DMT symbols. After that, the VTU-R shall transition into the channel analysis and exchange phase. The VTU-O shall transition to the channel analysis and exchange phase after transmission of O-P-SYNCHRO 5.

NOTE 3 – Figure 12-8 shows the complete training phase with TEQ and EC training stages, both upstream and downstream. The training phase may be shortened if some or all of these stages are not required. Since the lengths are determined based on the values communicated by the VTU-O and VTU-R during the channel discovery phase, one or more of the training stages can be reduced to the minimum length, thereby shortening the overall training time.

From the start of the training phase and for the remainder of initialization, the VTU-O and VTU-R shall transmit signals with the PSDs that are determined at the end of the channel discovery phase (i.e., including power cut-backs in the upstream and downstream transmission directions), as described in clause 12.3.4.3.

The signals and SOC messages sent by the VTU-O during the training phase are summarized in Table 12-39, and the signals and SOC messages sent by the VTU-R during the training phase are summarized in Table 12-40. The protocol used for SOC messages is provided, where applicable, in parentheses in the column labelled "SOC state".

Table 12-39 – VTU-O signals and SOC messages in the training phase

Signal	Signal type	Signal duration in DMT symbols with CE	SOC messages and IDLE flags	SOC state
O-P-TRAINING 1	Non-periodic	Variable	None	Inactive
O-P-SYNCHRO 4	Non-periodic	15	None	Inactive
O-P-PILOT 2	Non-periodic	$T_{\text{VTU-O_TEQ}}$	None	Inactive
O-P-TEQ	Periodic	$T_{\text{VTU-R_TEQ}}$	None	Inactive
O-P-ECT	Vendor discretionary	$T_{\text{VTU-O_EC}}$	None	Inactive
O-P-PILOT 3	Non-periodic	$T_{\text{VTU-R_EC}}$	None	Inactive

Table 12-39 – VTU-O signals and SOC messages in the training phase

Signal	Signal type	Signal duration in DMT symbols with CE	SOC messages and IDLE flags	SOC state
O-P-PERIODIC 2	Periodic	T_{Periodic}	None	Inactive
O-P-TRAINING 2	Non-periodic	Variable	O-IDLE, O-TA_UPDATE	Active (RQ)
O-P-SYNCHRO 5	Non-periodic	15	None	Inactive

Table 12-40 – VTU-R signals and SOC messages in the training phase

Signal	Signal type	Signal duration in DMT symbols with CE	SOC messages and IDLE flags	SOC state
R-P-QUIET 2	None	Variable, $\leq 4\ 096$	None	Inactive
R-P-TRAINING 1	Non-periodic	Variable, $>T_{\text{MIN-R-P-Train}}$	None	Inactive
R-P-SYNCHRO 4	Non-periodic	15	None	Inactive
R-P-TEQ	Periodic	$T_{\text{VTU-O_TEQ}}$	None	Inactive
R-P-QUIET 3	None	$T_{\text{VTU-R_TEQ}} + T_{\text{VTU-O_EC}}$	None	Inactive
R-P-ECT	Vendor discretionary	$T_{\text{VTU-R_EC}}$	None	Inactive
R-P-PERIODIC 2	Periodic	T_{Periodic}	None	Inactive
R-P-TRAINING 2	Non-periodic	Variable	R-IDLE, R-TA_UPDATE	Active (RQ)
R-P-SYNCHRO 5	Non-periodic	15	None	Inactive

12.3.4.2 SOC message exchange during the training phase

Figure 12-9 illustrates the SOC message exchange between the VTU-O and VTU-R during the training phase. It also summarizes the content of each message.

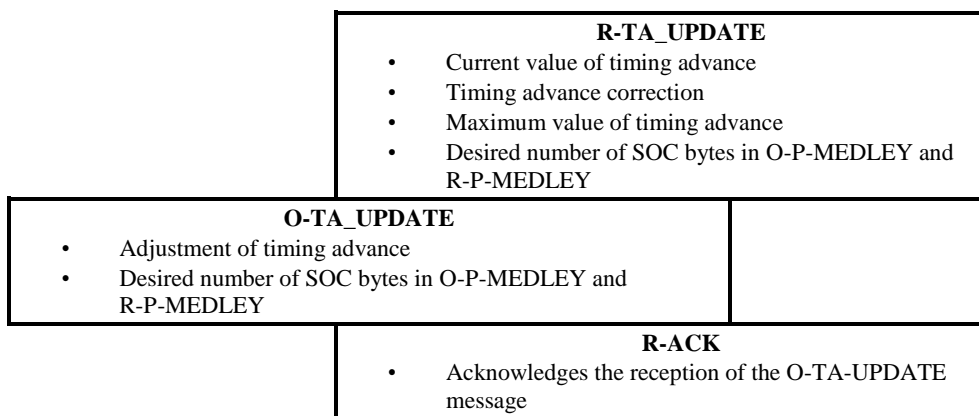

Figure 12-9 – SOC message exchange during the training phase

12.3.4.2.1 VTU-O messages sent during the training phase

12.3.4.2.1.1 O-TA_UPDATE

The full list of parameters carried by the O-TA_UPDATE message is shown in Table 12-41.

Table 12-41 – Description of message O-TA_UPDATE

	Field name	Format
1	Message descriptor	Message code
2	Timing advance correction	2 bytes
3	B _{ex-ds-O} (Desired number of SOC bytes per DMT symbol in O-P-MEDLEY)	1 byte
4	B _{ex-us-O} (Desired number of SOC bytes per DMT symbol in R-P-MEDLEY)	1 byte
5	ITU-T G.998.4 parameter field	Variable length
6	ITU-T G.993.5 parameter field	Variable length

Field #1 "Message descriptor" is a unique one-byte code that identifies the message. See Table 12-6 for a complete list of codes.

Field #2 "Timing advance correction" defines the timing advance correction that shall be used with respect to the current timing advance. It shall be expressed in samples at the upstream sampling rate corresponding to the IDFT size communicated in Field #6 of R-PRM. The value shall be encoded in a 16-bit field using twos complement format. Positive values shall indicate that the transmitted symbol will be advanced more with respect to the received symbol.

Field #3 "B_{ex-ds-O}" specifies the VTU-O's choice for the number of SOC bytes per DMT symbol that should be used to modulate O-P-MEDLEY. This number shall be either one or two. The actual number of SOC bytes per DMT symbol shall be the minimum of the values indicated in O-TA_UPDATE and R-TA_UPDATE (i.e., equal to $\min(B_{ex-ds-O}, B_{ex-ds-R})$).

Field #4 "B_{ex-us-O}" specifies the VTU-O's choice for the number of SOC bytes per DMT symbol that should be used to modulate R-P-MEDLEY. This number shall be either one or two. The actual number of SOC bytes per DMT symbol shall be the minimum of the values indicated in O-TA_UPDATE and R-TA_UPDATE (i.e., equal to $\min(B_{ex-us-O}, B_{ex-us-R})$).

Field #5 is a variable length field consisting of an integer number of bytes. It is formatted as shown in Table 12-26.

Field #6 is a variable length field consisting of an integer number of bytes. It is formatted as shown in Table 12-26.

The actual data in the variable length fields 5 and 6 are beyond the scope of this Recommendation. For a correct interpretation at the receiver, support of either [ITU-T G.998.4] or [ITU-T G.993.5] or both is required. However, support of those Recommendations is not implied or required for compliance with Recommendation ITU-T G.993.2.

If the VTU-O does not support [ITU-T G.998.4], the ITU-T G.998.4 parameter field shall be a single byte with value 0.

If the VTU-O does not support [ITU-T G.993.5], the ITU-T G.993.5 parameter field shall be a single byte with value 0.

12.3.4.2.2 VTU-R messages sent during the training phase

12.3.4.2.2.1 R-TA_UPDATE

The full list of parameters carried by the R-TA_UPDATE message is shown in Table 12-42.

Table 12-42 – Description of message R-TA_UPDATE

	Field name	Format
1	Message descriptor	Message code
2	Current timing advance	2 bytes
3	Timing advance correction	2 bytes
4	Maximum value of timing advance	2 bytes
5	$B_{\text{ex-ds-R}}$ (Desired number of SOC bytes per DMT symbol in O-P-MEDLEY)	1 byte
6	$B_{\text{ex-us-R}}$ (Desired number of SOC bytes per DMT symbol in R-P-MEDLEY)	1 byte
7	ITU-T G.998.4 parameter field	Variable length
8	ITU-T G.993.5 parameter field	Variable length

Field #1 "Message descriptor" is a unique one-byte code that identifies the message. See Table 12-6 for a complete list of codes.

Field #2 "Current timing advance" gives the timing advance currently being used by the VTU-R. The field is expressed in samples at the upstream sampling rate corresponding to the IDFT size communicated in Field #6 of R-PRM. The value shall be encoded in a 16-bit field using twos complement format.

Field #3 "Timing advance correction" indicates the timing advance correction, with respect to the current timing advance, preferred by the VTU-R in samples at the upstream sampling rate corresponding to the IDFT size communicated in Field #6 of R-PRM. The value shall be encoded in a 16-bit field using twos complement format. Positive values shall indicate that the transmitted symbol will be advanced more with respect to the received symbol.

Field #4 "Maximum value of timing advance" indicates the maximum value of timing advance that the VTU-R can accommodate in samples at the current upstream sampling rate corresponding to the IDFT size communicated in Field #6 of R-PRM. The value shall be encoded in a 16-bit field using twos complement format.

Field #5 " $B_{\text{ex-ds-R}}$ " specifies the VTU-R's choice for the number of SOC bytes per DMT symbol that should be used to modulate O-P-MEDLEY. This number shall be either one or two. The actual number of SOC bytes per DMT symbol shall be the minimum of the values indicated in O-TA_UPDATE and R-TA_UPDATE (i.e., equal to $\min(B_{\text{ex-ds-O}}, B_{\text{ex-ds-R}})$).

Field #6 " $B_{\text{ex-us-R}}$ " specifies the VTU-R's choice for the number of SOC bytes per DMT symbol that should be used to modulate R-P-MEDLEY. This number shall be either one or two. The actual number of SOC bytes per DMT symbol shall be the minimum of the values indicated in O-TA_UPDATE and R-TA_UPDATE (i.e., equal to $\min(B_{\text{ex-us-O}}, B_{\text{ex-us-R}})$).

Field #7 is a variable length field consisting of an integer number of bytes. It is formatted as shown in Table 12-26.

Field #8 is a variable length field consisting of an integer number of bytes. It is formatted as shown in Table 12-26.

The actual data in the variable length fields 7 and 8 are beyond the scope of this Recommendation. For a correct interpretation at the receiver, support of either [ITU-T G.998.4] or [ITU-T G.993.5] or both is required. However, support of those Recommendations is not implied or required for compliance with Recommendation ITU-T G.993.2.

If the VTU-R does not support [ITU-T G.998.4], the ITU-T G.998.4 parameter field shall be a single byte with value 0.

If the VTU-R does not support [ITU-T G.993.5], the ITU-T G.993.5 parameter field shall be a single byte with value 0.

12.3.4.2.2 R-ACK

R-ACK is a one-byte message that acknowledges correct reception of the O-TA_UPDATE message. The format of the message shall be as specified in clause 12.2.1, and the payload shall be as specified in Table 12-6.

12.3.4.3 Signals transmitted during the training phase

All signals transmitted during the training phase, except O-P-TEQ and R-P-TEQ, shall use only subcarriers from the MEDLEY_{ds} set in the downstream direction and subcarriers from the MEDLEY_{us} set in the upstream direction. O-P-TEQ and R-P-TEQ also use out-of-MEDLEY subcarriers, as described in clauses 12.3.4.3.1.4 and 12.3.4.3.2.4.

The transmit PSD of downstream signals with non-zero output power shall comply with the downstream MEDLEY reference PSD mask (MREFMASK_{ds}) that was established at the end of the channel discovery phase in both the passband and the stopbands. The values of $2N_{ds}$ and CE shall be those determined at the end of the channel discovery phase and communicated in Fields #7 and #4 in O-PRM, respectively. The values of β_{ds} and cyclic prefix length shall be as communicated in Field #6 and Field #5 of O-PRM, respectively.

The transmit PSD of all upstream signals with non-zero output power shall comply with the upstream MEDLEY reference PSD mask (MREFMASK_{us}) that was established at the end of the channel discovery phase in both the passband and the stopbands. The values of $2N_{us}$ and CE shall be those determined at the end of the channel discovery phase and communicated in Field #6 of R-PRM and Field #4 in O-PRM, respectively. The values of β_{us} and cyclic prefix length shall be those communicated in Fields #5 and #4 of R-PRM, respectively.

12.3.4.3.1 Signals transmitted by the VTU-O

12.3.4.3.1.1 O-P-TRAINING 1

The O-P-TRAINING 1 signal allows the VTU-R to re-synchronize and establish correct symbol timing. During transmission of O-P-TRAINING 1, the SOC is in its inactive state.

The duration of O-P-TRAINING 1 is variable. The VTU-O terminates O-P-TRAINING 1 by transmitting O-P-SYNCHRO 4.

O-P-TRAINING 1 shall be composed of all subcarriers in the MEDLEY_{ds} set. These subcarriers shall be modulated by 4-QAM. O-P-TRAINING 1 carries one byte per DMT symbol. The constellation points on all subcarriers shall be rotated based on the 2-bit number provided by the quadrant scrambler described in clause 12.3.6.2. The scrambler shall be used in reset mode (see clause 12.3.6.2.1).

The one byte carried by O-P-TRAINING 1 shall be the output of a PRBS generator with the same polynomial as the PRBS used for the quadrant scrambler (see clause 12.3.6.2). This PRBS generator shall not be reset and shall not skip any bits between DMT symbols. The initial state of this PRBS (for the first symbol of O-P-TRAINING 1) shall be all ones. The mapping of bits to subcarriers shall be as shown in Table 12-43.

Symbols shall be generated as described in clause 10.4.4. The symbol length shall be $2N_{ds}+L_{CE}$ samples. The overall window length shall be equal to β_{ds} .

The transmit PSD of the MEDLEY_{ds} subcarriers shall be equal to the downstream MEDLEY reference PSD (MREFPSD_{ds}) communicated in Field #2 of O-PRM.

Table 12-43 – Bit mapping for O-P-TRAINING 1

Subcarrier index	Constellation point
Even	00
1, 11, 21, ..., $10n+1$, ...	First 2 bits from the PRBS byte
3, 13, 23, ..., $10n+3$, ...	Second 2 bits from the PRBS byte
5, 15, 25, ..., $10n+5$, ...	Third 2 bits from the PRBS byte
7, 17, 27, ..., $10n+7$, ...	Fourth 2 bits from the PRBS byte
9, 19, 29, ..., $10n+9$, ...	00
NOTE – The byte is given as (b7, b6, b5, b4, b3, b2, b1, b0), where b7 is the MSB and b0 is the LSB. Mapping, e.g., "SOC message bits 0 and 1" to subcarriers $10n+1$ means that the two-bit value (b1,b0) shall be used to determine the constellation point in accordance with the encoding rules given in clause 10.3.3.2. This constellation point will then be scrambled using the quadrant scrambler described in clause 12.3.6.2.	

12.3.4.3.1.2 O-P-SYNCHRO 4

O-P-SYNCHRO 4 provides an exact time marker for transitions from O-P-TRAINING 1 to O-P-PILOT 2. During transmission of O-P-SYNCHRO 4, the SOC is in its inactive state.

The duration of O-P-SYNCHRO 4 is 15 DMT symbols.

O-P-SYNCHRO 4 shall use all subcarriers in the MEDLEYds set modulated by 4-QAM. The value 11 shall be mapped to all MEDLEYds subcarriers for the first 5 and the last 5 DMT symbols. The value 00 shall be mapped to all of the MEDLEYds subcarriers for the middle 5 DMT symbols. The constellation points on all subcarriers shall be rotated based on the 2-bit number provided by the quadrant scrambler described in clause 12.3.6.2. The scrambler shall be used in reset mode (see clause 12.3.6.2.1).

Symbols shall be generated as described in clause 10.4.4. The symbol length shall be $2N_{ds}+L_{CE}$ samples. The overall window length shall be equal to β_{ds} .

The transmit PSD of the MEDLEYds subcarriers in O-P-SYNCHRO 4 shall be the same as for O-P-TRAINING 1.

12.3.4.3.1.3 O-P-PILOT 2

The O-P-PILOT 2 signal is intended to allow the VTU-R to maintain loop timing during VTU-O TEQ training. During O-P-PILOT 2 the SOC is in its inactive state.

The duration of O-P-PILOT 2 is T_{VTU-O_TEQ} DMT symbols with CE. The value of T_{VTU-O_TEQ} shall be set to the maximum of the durations requested by the VTU-R in R-PRM and by the VTU-O in O-PRM.

O-P-PILOT 2 consists only of the pilot tones that were chosen by the VTU-R and communicated to the VTU-O in the Field #5 of R-MSG 1 during the channel discovery phase. A value of 00 shall be mapped to all pilot tones with 4-QAM modulation during every symbol of O-P-PILOT 2.

Symbols shall be generated as described in clause 10.4.4. The symbol length shall be $2N_{ds}+L_{CE}$ samples. The overall window length shall be equal to β_{ds} .

The O-P-PILOT 2 signal shall respect MREFMASKds as established at the conclusion of the channel discovery phase. The transmit power of pilot tones shall be set to 0 if the second MSB of the O-P-PILOT settings field of R-MSG 1 during the channel discovery phase is set to ZERO.

12.3.4.3.1.4 O-P-TEQ

O-P-TEQ is a periodic signal. It allows the VTU-R to train its TEQ. During the transmission of

O-P-TEQ, the SOC is in its inactive state.

The duration of O-P-TEQ is T_{VTU-R_TEQ} DMT symbols with CE. The value of T_{VTU-R_TEQ} shall be set to the maximum of the durations requested by the VTU-R in R-PRM and by the VTU-O in O-PRM.

O-P-TEQ shall use all subcarriers from the MEDLEYds set, as well as the out-of-MEDLEYds subcarriers with indices between 1 and $t_{DS1_stop} + 32$, where t_{DS1_stop} is the highest-index subcarrier in the MEDLEYds set included in DS1.

O-P-TEQ shall map the 4-QAM value of 11 on each subcarrier. The constellation points on all subcarriers shall be rotated based on the 2-bit number provided by the quadrant scrambler described in clause 12.3.6.2. The scrambler shall be used in reset mode (see clause 12.3.6.2.1).

O-P-TEQ shall be constructed as described in clause 12.3.6.1.

The transmit PSD of the MEDLEYds subcarriers in O-P-TEQ shall be the same as for O-P-TRAINING 1. The transmit PSD shall incorporate the t_{SSi} values that were sent by the VTU-O during the channel discovery phase (see clause 12.3.3.2.1.3).

12.3.4.3.1.5 O-P-ECT

The O-P-ECT signal allows the VTU-O to train its echo canceller. During transmission of O-P-ECT, the SOC is in its inactive state.

The duration of O-P-ECT is T_{VTU-O_EC} DMT symbols with CE. The value of T_{VTU-O_EC} shall be as indicated by the VTU-O in O-PRM.

O-P-ECT is a vendor-discretionary signal. However, in order to allow the VTU-R to maintain loop timing, O-P-ECT shall include any pilot tones selected by the VTU-R during the channel discovery phase.

The PSD of O-P-ECT shall respect MREFMASKds as established at the conclusion of the channel discovery phase.

12.3.4.3.1.6 O-P-PILOT 3

The O-P-PILOT 3 signal is intended to allow the VTU-R to maintain loop timing during echo canceller training. During the transmission of O-P-PILOT 3, the SOC is in its inactive state.

The duration of O-P-PILOT 3 is T_{VTU-R_EC} DMT symbols with CE. The value of T_{VTU-R_EC} shall be as indicated by the VTU-R in R-PRM.

O-P-PILOT 3 consists only of the pilot tones that were chosen by the VTU-R and communicated to the VTU-O in Field #5 of R-MSG 1 during the channel discovery phase. A value of 00 shall be mapped to all pilot tones with 4-QAM modulation during every symbol of O-P-PILOT 3.

Symbols shall be generated as described in clause 10.4.4. The symbol length shall be $2N_{ds} + L_{CE}$ samples. The overall window length shall be equal to β_{ds} .

The O-P-PILOT 3 signal shall respect MREFMASKds as established at the conclusion of the channel discovery phase. The transmit power of pilot tones shall be set to 0 if the third MSB of the O-P-PILOT settings field of R-MSG 1 during the channel discovery phase is set to ZERO.

12.3.4.3.1.7 O-P-PERIODIC 2

O-P-PERIODIC 2 is a periodic signal. During the transmission of O-P-PERIODIC 2, the SOC is in its inactive state.

The duration of O-P-PERIODIC 2, $T_{Periodic}$ DMT symbols with CE, is the maximum of the durations requested by the VTU-R in R-PRM and by the VTU-O in O-PRM.

O-P-PERIODIC 2 shall be composed of all subcarriers in the MEDLEYds set. These subcarriers shall be modulated by 4-QAM. The value 11 shall be mapped to all of the subcarriers. The constellation

points on all subcarriers shall be rotated based on the 2-bit number provided by the quadrant scrambler described in clause 12.3.6.2. The scrambler shall be used in reset mode (see clause 12.3.6.2.1).

O-P-PERIODIC 2 shall be constructed as described in clause 12.3.6.1.

The transmit PSD of the MEDLEYds subcarriers in O-P-PERIODIC 2 shall be the same as for O-P-TRAINING 1.

12.3.4.3.1.8 O-P-TRAINING 2

The O-P-TRAINING 2 signal allows the VTU-R to re-establish SOC message exchange between the VTU-O and VTU-R. During the transmission of O-P-TRAINING 2, the SOC is in its active state.

The duration of O-P-TRAINING 2 is variable. The VTU-O terminates O-P-TRAINING 2 by transmitting O-P-SYNCHRO 5, which completes the training phase.

O-P-TRAINING 2 shall be composed of all subcarriers in the MEDLEYds set modulated by 4-QAM.

O-P-TRAINING 2 shall carry one byte of information per DMT symbol. The mapping of bits to subcarriers shall be as summarized in Table 12-44.

Table 12-44 – Bit mapping for O-P-TRAINING 2

Subcarrier index	Constellation point
Even	00
1, 11, 21, ..., $10n+1$, ...	SOC message bits 0 and 1
3, 13, 23, ..., $10n+3$, ...	SOC message bits 2 and 3
5, 15, 25, ..., $10n+5$, ...	SOC message bits 4 and 5
7, 17, 27, ..., $10n+7$, ...	SOC message bits 6 and 7
9, 19, 29, ..., $10n+9$, ...	00
NOTE – The byte is given as (b7, b6, b5, b4, b3, b2, b1, b0), where b7 is the MSB and b0 is the LSB. Mapping, e.g., "SOC message bits 0 and 1" to subcarriers $10n+1$ means that the two-bit value (b1,b0) shall be used to determine the constellation point in accordance with the encoding rules given in clause 10.3.3.2. This constellation point will then be scrambled using the quadrant scrambler described in clause 12.3.6.2.	

The constellation points on all subcarriers shall be rotated based on the 2-bit number provided by the quadrant scrambler described in clause 12.3.6.2. The scrambler shall be used in reset mode (see clause 12.3.6.2.1).

Symbols shall be generated as described in clause 10.4.4. The symbol length shall be $2N_{ds}+L_{CE}$ samples. The overall window length shall be equal to β_{ds} .

The transmit PSD of the MEDLEYds subcarriers in O-P-TRAINING 2 shall be the same as for O-P-TRAINING 1.

12.3.4.3.1.9 O-P-SYNCHRO 5

The O-P-SYNCHRO 5 is a signal that provides an exact time marker for transitions from O-P-TRAINING 2 to O-P-MEDLEY (the beginning of the channel analysis and exchange phase).

O-P-SYNCHRO 5 shall be identical to O-P-SYNCHRO 4.

12.3.4.3.2 Signals transmitted by the VTU-R

12.3.4.3.2.1 R-P-QUIET 2

R-P-QUIET 2 shall provide a zero output voltage at the U reference point. All subcarriers shall be transmitted at zero power. The duration of R-P-QUIET 2 is left to the discretion of the VTU-R, but

shall not exceed 4 096 DMT symbols with CE.

12.3.4.3.2.2 R-P-TRAINING 1

The R-P-TRAINING 1 signal is the first signal sent by the VTU-R after re-establishing synchronization. During transmission of R-P-TRAINING 1, the SOC is in its inactive state.

The duration of R-P-TRAINING 1 is variable.

R-P-TRAINING 1 shall be composed of all subcarriers in the MEDLEY_{us} set. These subcarriers shall be modulated by 4-QAM. R-P-TRAINING 1 carries one byte per DMT symbol. The one byte and the mapping of bits to subcarriers shall be as shown in Table 12-45.

Table 12-45 – Bit mapping for R-P-TRAINING 1

Subcarrier index	Constellation point
Even	00
1, 11, 21, ..., 10n+1, ...	01
3, 13, 23, ..., 10n+3, ...	11
5, 15, 25, ..., 10n+5, ...	11
7, 17, 27, ..., 10n+7, ...	10
9, 19, 29, ..., 10n+9, ...	00

The constellation points on all subcarriers shall be rotated based on the 2-bit number provided by the quadrant scrambler described in clause 12.3.6.2. The scrambler shall be used in reset mode (see clause 12.3.6.2.1).

Symbols shall be generated as described in clause 10.4.4. The symbol length shall be $2N_{us}+L_{CE}$ samples. The overall window length shall be equal to β_{us} .

The transmit PSD of the MEDLEY_{us} subcarriers in R-P-TRAINING 1 shall be equal to the upstream MEDLEY reference PSD (MREFPSD_{us}) communicated in Field #2 of R-PRM.

12.3.4.3.2.3 R-P-SYNCHRO 4

R-P-SYNCHRO 4 provides an exact time marker for transition from R-P-TRAINING 1 to R-P-TEQ. During transmission of R-P-SYNCHRO 4, the SOC is in its inactive state.

The duration of R-P-SYNCHRO 4 is 15 DMT symbols.

R-P-SYNCHRO 4 shall use all subcarriers in the MEDLEY_{us} set modulated by 4-QAM. The value 11 shall be mapped to all MEDLEY_{us} subcarriers for the first 5 and the last 5 DMT symbols. The value 00 shall be mapped to all MEDLEY_{us} subcarriers for the middle 5 DMT symbols. The constellation points on all subcarriers shall be rotated based on the 2-bit number provided by the quadrant scrambler described in clause 12.3.6.2. The scrambler shall be used in reset mode (see clause 12.3.6.2.1).

Symbols shall be generated as described in clause 10.4.4. The symbol length shall be $2N_{us}+L_{CE}$ samples. The overall window length shall be equal to β_{us} .

The transmit PSD of the MEDLEY_{us} subcarriers in R-P-SYNCHRO 4 shall be the same as for R-P-TRAINING 1.

12.3.4.3.2.4 R-P-TEQ

R-P-TEQ is a periodic signal. It allows the VTU-O to train its TEQ. During the transmission of R-P-TEQ, the SOC is in its inactive state.

The duration of R-P-TEQ is T_{VTU-O_TEQ} DMT symbols with CE. The value of T_{VTU-O_TEQ} shall be set to the maximum of the durations requested by the VTU-R in R-PRM and by the VTU-O in O-PRM.

R-P-TEQ shall use all of the subcarriers from the MEDLEYus set, as well as the out-of-MEDLEYus subcarriers with indices between 1 and $t_{US0_stop} + 32$, where t_{US0_stop} is the highest-index subcarrier included in US0.

R-P-TEQ shall map the 4-QAM value of 11 on each subcarrier. The constellation points on all subcarriers shall be rotated based on the 2-bit number provided by the quadrant scrambler described in clause 12.3.6.2. The scrambler shall be used in reset mode (see clause 12.3.6.2.1).

R-P-TEQ shall be constructed as described in clause 12.3.6.1.

The transmit PSD of the MEDLEYus subcarriers in R-P-TEQ shall be the same as for R-P-TRAINING 1. The transmit PSD shall incorporate the t_{SSi} values that were sent by the VTU-R during the channel discovery phase (see clause 12.3.3.2.2.3).

12.3.4.3.2.5 R-P-QUIET 3

R-P-QUIET 3 shall provide a zero output voltage at the U reference point. All subcarriers shall be transmitted at zero power. The duration of R-P-QUIET 3 shall be $T_{VTU-R_TEQ} + T_{VTU-O_EC}$ DMT symbols with CE.

12.3.4.3.2.6 R-P-ECT

The R-P-ECT signal allows the VTU-R to train its echo canceller. R-P-ECT is a vendor-discretionary signal. During transmission of R-P-ECT, the SOC is in its inactive state.

The duration of R-P-ECT is T_{VTU-R_EC} DMT symbols with CE. The value T_{VTU-R_EC} shall be as indicated by the VTU-R in R-PRM.

The PSD of R-P-ECT shall respect MREFMASKus as established at the conclusion of the channel discovery phase.

12.3.4.3.2.7 R-P-PERIODIC 2

R-P-PERIODIC 2 is a periodic signal. During the transmission of R-P-PERIODIC 2, the SOC is in its inactive state.

The duration of R-P-PERIODIC 2, $T_{Periodic}$ DMT symbols with CE, is the maximum of the durations requested by the VTU-O in O-PRM and by the VTU-R in R-PRM.

R-P-PERIODIC 2 shall be composed of all subcarriers in the MEDLEYus set. These subcarriers shall be modulated by 4-QAM. The value 11 shall be mapped to each subcarrier. The constellation points on all subcarriers shall be rotated based on the 2-bit number provided by the quadrant scrambler described in clause 12.3.6.2. The scrambler shall be used in reset mode (see clause 12.3.6.2.1).

R-P-PERIODIC 2 shall be constructed as described in clause 12.3.6.1.

The transmit PSD of the MEDLEYus subcarriers in R-P-PERIODIC 2 shall be the same as for R-P-TRAINING 1.

12.3.4.3.2.8 R-P-TRAINING 2

The R-P-TRAINING 2 signal re-establishes SOC message exchange between the VTU-O and VTU-R. During transmission of R-P-TRAINING 2, the SOC is in its active state.

The duration of R-P-TRAINING 2 is variable. The VTU-R terminates R-P-TRAINING 2 when it receives O-P-SYNCHRO 5.

R-P-TRAINING 2 shall be composed of all subcarriers in the MEDLEYus set. These subcarriers shall be modulated by 4-QAM. R-P-TRAINING 2 shall carry one byte of information per DMT symbol. The bit mapping shall be as summarized in Table 12-46.

Table 12-46 – Bit mapping for R-P-TRAINING 2

Subcarrier index	Constellation point
Even	00
1, 11, 21, ..., $10n+1$, ...	SOC message bits 0 and 1
3, 13, 23, ..., $10n+3$, ...	SOC message bits 2 and 3
5, 15, 25, ..., $10n+5$, ...	SOC message bits 4 and 5
7, 17, 27, ..., $10n+7$, ...	SOC message bits 6 and 7
9, 19, 29, ..., $10n+9$, ...	00
NOTE – The byte is given as (b7, b6, b5, b4, b3, b2, b1, b0), where b7 is the MSB and b0 is the LSB. Mapping, e.g., "SOC message bits 0 and 1" to subcarriers $10n+1$ means that the two-bit value (b1,b0) shall be used to determine the constellation point in accordance with the encoding rules given in clause 10.3.3.2. This constellation point will then be scrambled using the quadrant scrambler described in clause 12.3.6.2.	

The constellation points on all subcarriers shall be rotated based on the 2-bit number provided by the quadrant scrambler described in clause 12.3.6.2. The scrambler shall be used in reset mode (see clause 12.3.6.2.1).

Symbols shall be generated as described in clause 10.4.4. The symbol length shall be $2N_{us}+L_{CE}$ samples. The overall window length shall be equal to β_{us} .

The transmit PSD of the MEDLEY_{us} subcarriers in R-P-TRAINING 2 shall be the same as for R-P-TRAINING 1.

12.3.4.3.2.9 R-P-SYNCHRO 5

R-P-SYNCHRO 5 is a signal that provides an exact time marker for transition from R-P-TRAINING 2 to R-P-MEDLEY (the beginning of the channel analysis and exchange phase).

R-P-SYNCHRO 5 shall be identical to R-P-SYNCHRO 4.

12.3.5 Channel analysis and exchange phase

12.3.5.1 Overview

During the channel analysis and exchange phase, SNR estimation is performed. Both VTUs exchange their capabilities and the final configuration for both upstream and downstream transmission is selected on the basis of these capabilities.

Figure 12-10 presents the timing diagram for the stages of the channel analysis and exchange phase. It gives an overview of the sequence of signals transmitted and the sequence of SOC messages sent by the VTU-O and VTU-R during the channel analysis and exchange phase. The two inner columns show the sequences of signals that are transmitted (see clause 12.3.5.3). The two outer columns show the messages that are sent over the SOC (see clause 12.3.5.2). The shaded areas correspond to periods of time when the SOC is in its inactive state.

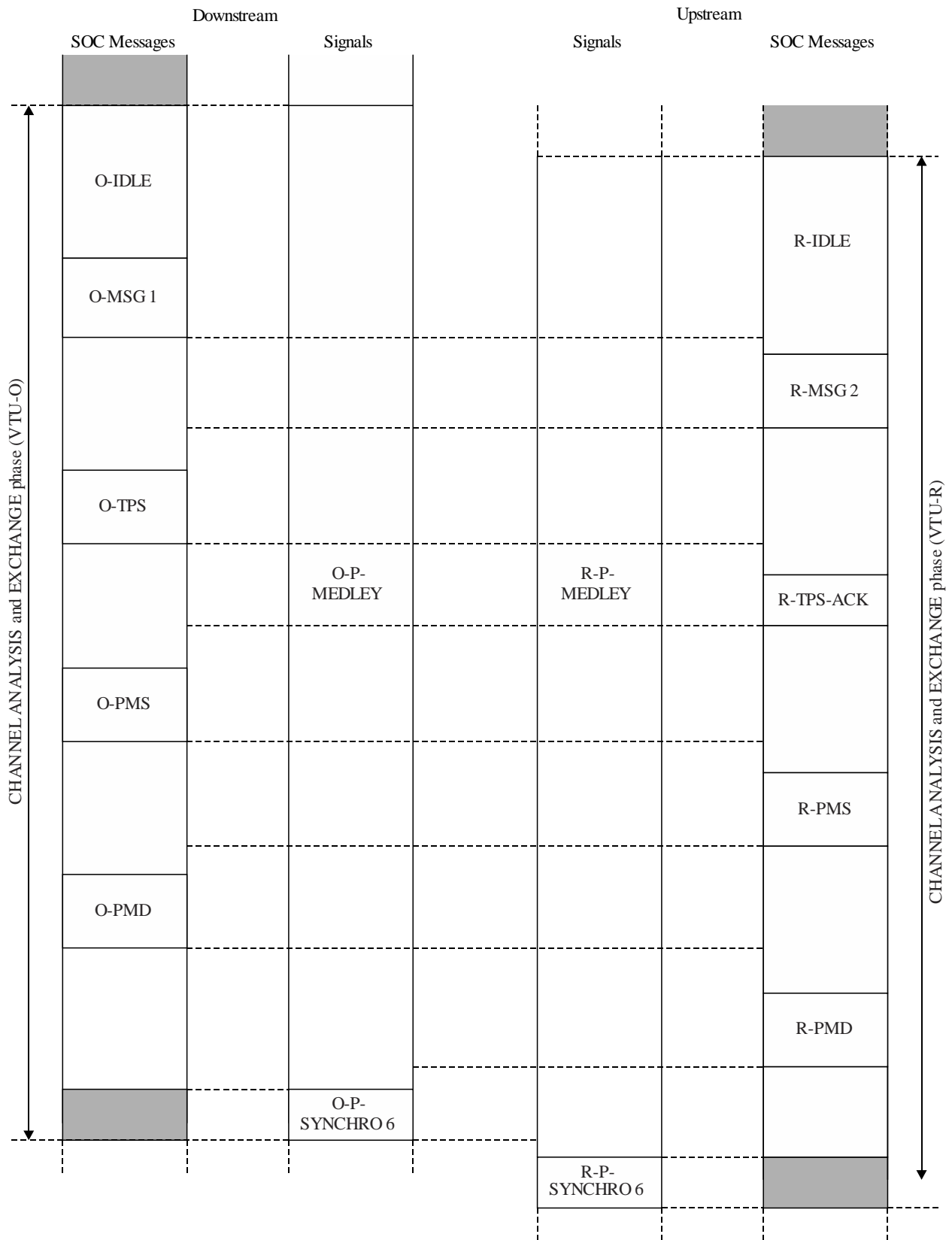

G.993.2(15)_F12-10

Figure 12-10 – Timing diagram for the stages of the channel analysis and exchange phase

NOTE – In the exchange of the SOC messages identified in Figure 12-10, the rules of the communication protocol of clause 12.2.2 apply. Some messages sent in the SOC may require segmentation; although this is not shown in Figure 12-10, the segmented message elements and their corresponding acknowledgements are sent via the SOC as per the communication protocol of clause 12.2.2.

The channel analysis and exchange phase involves the following steps as shown in Figure 12-10:

- 1) The VTU-O sends the O-MSG 1 message, which contains its capabilities and a number of (downstream) configuration parameters.
- 2) The VTU-R replies by sending the R-MSG 2 message, which indicates its capabilities.
- 3) The VTU-O sends the O-TPS message to indicate the configuration of the bearer channels and their required capabilities for both the upstream and the downstream directions.
- 4) The VTU-R acknowledges the O-TPS message with the R-TPS-ACK message.
- 5) The VTU-O conveys the upstream PMS-TC (framing) parameters by sending the O-PMS message.
- 6) The VTU-R conveys the downstream PMS-TC (framing) parameters by sending the R-PMS message.
- 7) The VTU-O sends the O-PMD message, which contains the bits, gains and tone ordering tables for the upstream PMD.
- 8) The VTU-R sends the R-PMD message, which contains the bits, gains and tone ordering tables for the downstream PMD.

After sending R-PMD, the VTUs are ready to transition to showtime. The trigger for stepping into showtime shall be given by O-P-SYNCHRO 6 and R-P-SYNCHRO 6 for the downstream and upstream transmission directions, respectively. R-P-SYNCHRO 6 shall be transmitted within 64 symbols of detecting O-P-SYNCHRO 6.

The first DMT symbol following O-P-SYNCHRO 6 shall be the first downstream symbol of showtime. Likewise, the first DMT symbol following R-P-SYNCHRO 6 shall be the first upstream symbol of showtime. The PMD, PMS-TC and TPS-TC parameter settings negotiated during the channel analysis and exchange phase shall be set starting from the first symbol of showtime.

The signals and SOC messages sent by the VTU-O during the channel analysis and exchange phase are summarized in Table 12-47, and the signals and SOC messages sent by the VTU-R during the channel analysis and exchange phase are summarized in Table 12-48. The protocol used for SOC messages is provided, where applicable, in parentheses in the column labelled "SOC state".

Table 12-47 – VTU-O signals and SOC messages in the channel analysis and exchange phase

Signal	Signal type	Signal duration in DMT symbols with CE	SOC messages	SOC state
O-P-MEDLEY	Non-periodic	Variable	O-MSG 1, O-TPS, O-PMS, O-PMD	Active (RQ)
O-P-SYNCHRO 6	Non-periodic	15	None	Inactive

Table 12-48 – VTU-R signals and SOC messages in the channel analysis and exchange phase

Signal	Signal type	Signal duration in DMT symbols with CE	SOC messages	SOC state
R-P-MEDLEY	Non-periodic	Variable	R-MSG 2, R-TPS-ACK, R-PMS, R-PMD	Active (RQ)
R-P-SYNCHRO 6	Non-periodic	15	None	Inactive

12.3.5.2 SOC messages exchanged during channel analysis and exchange phase

Figure 12-11 illustrates the SOC message exchange between the VTU-O and VTU-R during the channel analysis and exchange phase. It also summarizes the content of each message.

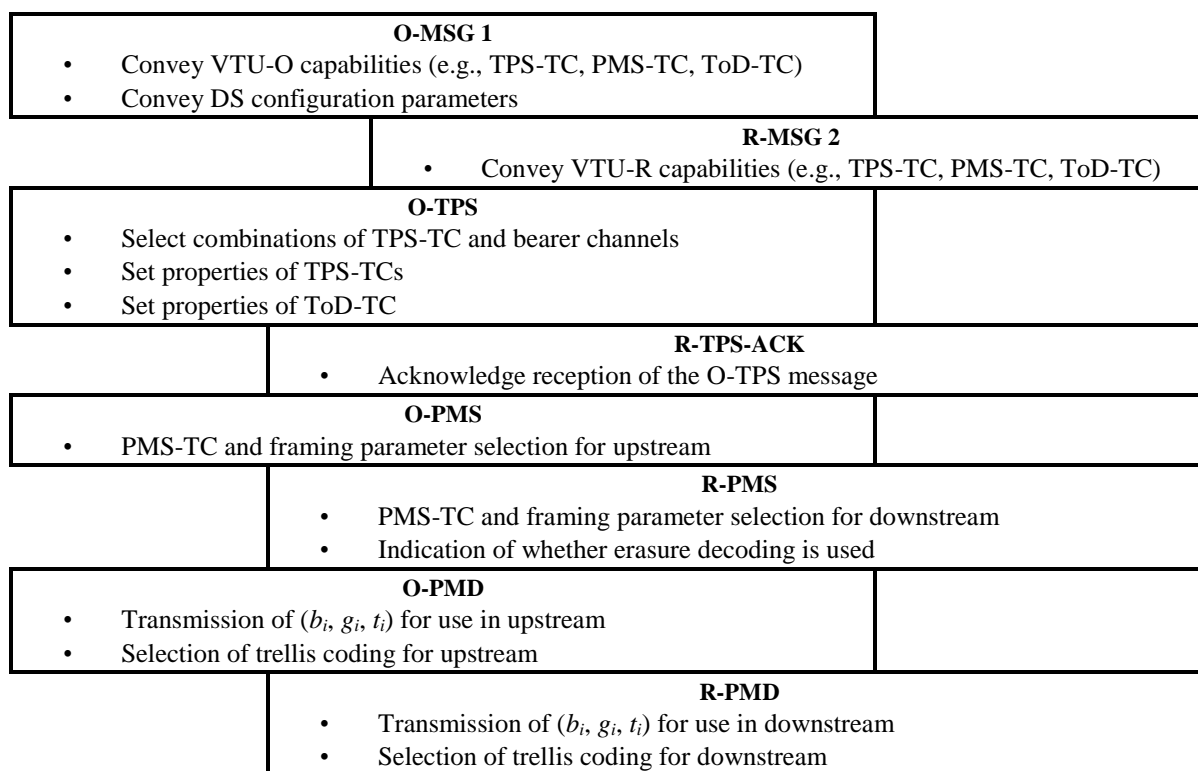

Figure 12-11 – SOC messages exchanged during the channel analysis and exchange phase

12.3.5.2.1 VTU-O messages sent during the channel analysis and exchange phase

12.3.5.2.1.1 O-MSG 1

The O-MSG 1 message contains the capabilities of the VTU-O and the requirements for downstream transmission (such as margin). The full list of parameters carried by the O-MSG 1 message is shown in Table 12-49.

Table 12-49 – Description of message O-MSG 1

	Field name	Format
1	Message descriptor	Message code
2	Downstream target SNR margin (TARSNRMds)	2 bytes
3	Downstream minimum SNR margin (MINSNRMds)	2 bytes
4	Downstream maximum SNR margin (MAXSNRMds)	2 bytes
5	RA-MODE	1 byte
6	NTR	1 byte
7	TPS-TC capabilities	see Table 12-50
8	PMS-TC capabilities	see Table 12-52
9	Downstream Rate adaptation downshift SNR margin (RA-DSNRMds)	2 bytes
10	Downstream Rate adaptation downshift time interval (RA-DTIMEds)	2 bytes
11	Downstream Rate adaptation upshift SNR margin (RA-USNRMds)	2 bytes
12	Downstream Rate adaptation upshift time interval (RA-UTIMEds)	2 bytes
13	Support of "Flexible OH frame type 2" downstream and INM_INPEQ_FORMATds	1 byte
14	SOS Multi-step activation downstream	1 byte
15	SOS Multi-step activation upstream	1 byte
16	MIN-SOS-BR-ds0	2 bytes
17	MIN-SOS-BR-ds1	2 bytes
18	SOS-TIME-ds	1 byte
19	SOS-NTONES-ds	1 byte
20	SOS-CRC-ds	2 bytes
21	MAX-SOS-ds	1 byte
22	SNRMOFFSET-ROC-ds	2 bytes
23	INPMIN-ROC-ds	1 byte
24	G.998.4 parameter field	Variable length
25	G.993.5 parameter field	Variable length
26	REINIT_TIME_THRESHOLDds	1 byte
27	Time synchronization capability	1 byte

Field #1 "Message descriptor" is a unique one-byte code that identifies the message. See Table 12-6 for a complete list of codes.

Field #2 "Downstream target SNR margin (TARSNRMds)" indicates the target SNR margin of the VTU-R receiver. The definition and use of this parameter shall be the same as for the parameter "Downstream Target Noise Margin (TARSNRMds)" specified in [ITU-T G.997.1]. The value and format of this parameter shall be the same as that in Field #12 of O-SIGNATURE (see clause 12.3.3.2.1.1).

Field #3 "Downstream minimum SNR margin (MINSNRMds)" is the minimum SNR margin the VTU-R shall tolerate. The definition and use of this parameter shall be the same as for the parameter "Downstream Minimum Noise Margin (MINSNRMds)" specified in [ITU-T G.997.1]. The field shall be formatted as a 16-bit unsigned integer with LSB weight of 0.1 dB and a valid range between 0 and 31 dB.

Field #4 "Downstream maximum SNR margin (MAXSNRMds)". The value and format for this parameter shall be the same as in Field #11 of O-SIGNATURE (see clause 12.3.3.2.1.1).

NOTE – Improper setting of one or more of the following parameters – maximum net data rate, downstream maximum SNR margin, impulse noise protection, maximum interleaving delay (in SNRM_MODE=1), and TXREFVN (in SNRM_MODE=2) – can result in high levels of transmit power that can lead to high crosstalk experienced by DSLs on other pairs in the same binder. Specifically, high values of maximum net data rate, downstream maximum SNR margin, impulse noise protection, low values of maximum interleaving delay (in SNRM_MODE=1), and high values of TXREFVN (in SNRM_MODE=2) are of concern.

Field #5 "RA-MODE" specifies the mode of operation of a rate-adaptive VTU-O in the downstream direction as defined in [ITU-T G.997.1]. This field shall be coded as an 8-bit integer with valid values 01_{16} , 02_{16} , 03_{16} and 04_{16} for RA-MODE 1, 2, 3 and 4, respectively.

Field #6 "NTR" shall be set to 01_{16} if the VTU-O is transporting the NTR signal in the downstream direction, otherwise it shall be set to 00_{16} .

Field #7 "TPS-TC capabilities" indicates the TPS-TC capabilities of the VTU-O as shown in Table 12-50.

Field #8 "PMS-TC capabilities" indicates the PMS-TC capabilities of the VTU-O. This includes the supported latency paths at the VTU-O (DS and US) and the capabilities per path (such as supported coding and interleaver parameters), as shown in Table 12-52.

Field #9 "Downstream Rate adaptation downshift SNR margin (RA-DSNRMds)": The definition and use of this parameter is specified in clause 13.4. The field shall be formatted as a 16-bit unsigned integer with LSB weight of 0.1 dB and has a valid range between 0 and 31.0 dB.

Field #10 "Downstream Rate adaptation downshift time interval (RA-DTIMEds)": The definition and use of this parameter is specified in clause 13.4. The field shall be formatted as a 16-bit unsigned integer with LSB weight of 1 s and has a valid range between 0 to 16 383 s.

Field #11 "Downstream Rate adaptation upshift SNR margin (RA-USNRMds)": The definition and use of this parameter is specified in clause 13.4. The field shall be formatted as a 16-bit unsigned integer with LSB weight of 0.1 dB and has a valid range between 0 and 31.0 dB.

Field #12 "Downstream Rate adaptation upshift time interval (RA-UTIMEds)": The definition and use of this parameter is specified in clause 13.4. The field shall be formatted as a 16-bit unsigned integer with LSB weight of 1 s and has a valid range between 0 to 16 383 s.

Field #13 indicates the support by the VTU-O of the "Flexible OH Frame Type 2" and INM_INPEQ_FORMATds in the downstream direction. The field shall be formatted as [0000 00ba]. The VTU-O shall indicate support by setting, respectively, a=1 and b=1 in this field. Other bits shall be set to 0 and are reserved by ITU-T.

Field #14 indicates the capabilities of the VTU-O to execute the SOS request in one step or in multiple steps in the downstream direction. The field is formatted as [gggg 0000]. The first four MSBs [gggg] indicate the maximum number of tones (G_{SOS}) that can be executed in a single step in the downstream direction. The valid values are:

- [0000]: All tones
- [0010]: $G_{SOS} = 256$ tones
- [0011]: $G_{SOS} = 512$ tones
- [0100]: $G_{SOS} = 1\ 024$ tones

If SOS is supported, value $G_{SOS} = 256$ tones is a mandatory capability. If the VTU supports a particular value of G_{SOS} , it shall support all smaller values of G_{SOS} (and values T_{SOS} associated with them, as presented in Table 13-4).

Each G_{SOS} has a value of T_{SOS} associated with it, where T_{SOS} is the time (in symbols) between the execution of two successive groups of tones (see clause 13.3).

If the CO does not support SOS in the downstream direction, this field shall contain a value within the specified valid range. This value shall be ignored at the receiver.

Field #15 indicates the capabilities of the VTU-O to execute the SOS request in one step or in multiple steps in the upstream direction. The format of the field and the valid values shall be the same as for field #14.

If the CO does not support SOS in the upstream direction, this field shall contain a value within the specified valid range. This value shall be ignored at the receiver. Field #16 Contains the value of the MIN-SOS-BR-ds0 as specified in the MIB. The parameter MIN-SOS-BR-ds0 is defined as the minimum net data rate required for a valid SOS request in the downstream direction (see clause 13.4) for bearer channel 0. The value shall be coded as an unsigned integer representing the data rate as a multiple of 8 kbit/s.

Field #17 Contains the value of the MIN-SOS-BR-ds1 as specified in the MIB. The parameter MIN-SOS-BR-ds1 is defined as the minimum net data rate required for a valid SOS request in the downstream direction (see clause 13.4) for bearer channel 1. The value shall be coded as an unsigned integer representing the data rate as a multiple of 8 kbit/s.

When only one bearer channel is supported, the value of Field #16 or Field #17 corresponding to the other bearer channel shall be set to $FFFF_{16}$. When two bearer channels are supported (as would be the case for dual latency or single latency with two bearer channels mapped into the single latency path) both fields shall contain valid values.

Field #18 Contains the value of the SOS triggering parameter SOS-TIME-ds as specified in the MIB. The parameter is used in the specification of the receiver initiated SOS (see clause 13.4.3). The special value zero, indicates that the standard SOS triggering criteria are disabled. If the value of this parameter is not zero, the standard SOS triggering criteria are enabled, and the value corresponds with duration of the time window used in the standard SOS triggering criteria.

The value shall be coded as an unsigned integer representing the duration of the time window as a multiple of 64 ms. The valid range of the non-zero values is from 64 to 16 320 ms.

Field #19 Contains the value of the SOS triggering parameter SOS-NTONES-ds as specified in the MIB. The parameter is used in the specification of the receiver initiated SOS (see clause 13.4.3). The parameter SOS-NTONES-ds is defined as a percentage of tones.

The valid range of values is from 0 to 100 in steps of 1. A special value of 0 indicates that SOS-NTONES-ds is not used in the decision criteria.

Field #20 Contains the value of the SOS triggering parameter SOS-CRC-ds as specified in the MIB. The parameter is used in the specification of the receiver initiated SOS (see clause 13.4.3).

The valid range of SOS-CRC-ds values is 0.02 to $((2^{16})-1) \times 0.02$, in steps of 0.02.

Field #21 Contains the value of MAX-SOS-ds as specified in the MIB. This parameter contains the maximum allowed number of successful SOS procedures within 120 seconds before the VTU-R shall transition to L3 state (see clause 12.1.4). The valid range of values is from 0 to 15. A special value of 0 indicates that there is no limit on the maximum allowed number of SOS recoveries within this time interval.

If the CO does not support SOS in the downstream direction, the fields #16 to #21 shall contain a value within the specified valid range for each of the parameters. These values shall be ignored at the receiver.

Field #22 contains the value of SNRMOFFSET-ROCs as specified in the MIB. The parameter is defined as the SNR Margin offset for the ROC in the downstream direction. This means that the target margin for the ROC is obtained by adding this value to TARSNRM (i.e., TARSNRM-ROC = TARSNRM + SNRMOFFSET-ROC).

The parameter TARSNRM-ROC is used in the specification of the Channel Initialization Policy (see clause 12.3.7.1).

The value shall be coded as an 16 bit unsigned integer with LSB weight of 0.1 dB. The valid range of values is from 0 to 31 dB with 0.1 dB steps. Field #23 contains the value of INPMIN-ROCs expressed in multiples of T_{4k} as specified in the MIB. The value of INPMIN-ROCs expressed in DMT symbols (as to be used by the VTU-R receiver as specified in clause 9.6), is calculated as follows:

For 4.3125 kHz subcarrier spacing:

INPMIN-ROCs in DMT symbols = INPMIN-ROCs in multiples of T_{4k} .

For 8.625 kHz subcarrier spacing:

INPMIN-ROCs in DMT symbols = $2 \times$ (INPMIN-ROCs in multiples of T_{4k}).

with T_{4k} as defined in clause 10.4.4.

The parameter INPMIN-ROCs (in DMT symbols) is defined as the required INP_no_erasure value for the ROC (see clause 9.6). The value of field #23 is an integer in the range from 0 to 8.

If the CO does not support a robust overhead channel in the downstream direction, the fields #22 and #23 shall contain a value within the specified valid range for each of the parameters. These values shall be ignored at the receiver.

Field #24 is a variable length field consisting of an integer number of bytes. It is formatted as shown in Table 12-26.

Field #25 is a variable length field consisting of an integer number of bytes. It is formatted as shown in Table 12-26.

The actual data in the variable length fields 24 and 25 are beyond the scope of this Recommendation. For a correct interpretation at the receiver, support of either [ITU-T G.998.4] or [ITU-T G.993.5] or both is required. However, support of those Recommendations is not implied or required for compliance with Recommendation ITU-T G.993.2.

If the VTU-O does not support [ITU-T G.998.4], the ITU-T G.998.4 parameter field shall be a single byte with value 0.

If the VTU-O does not support [ITU-T G.993.5], the ITU-T G.993.5 parameter field shall be a single byte with value 0.

Field #26 control parameter "*REINIT_TIME_THRESHOLDs*" contains the threshold for re-initialization based on SES as specified in the CO-MIB, to be used in downstream by the VTU-R receiver when Re-Initialization Policy 1 is used (see clause 12.4.1). The value shall be coded as an unsigned integer representing the maximum number of SES. The valid range is from 5 to 31.

Field #27 "Time Synchronization capability" indicates the time synchronization capability of the VTU-O. The field shall be coded as a single byte [0000 000t], where:

- t=0 indicates that time synchronization is not supported;
- t=1 indicates that time synchronization is supported.

Table 12-50 – TPS-TC capabilities of the VTU-O

Field name	Format	Description
Maximum number of downstream TPS-TCs of each type	1 byte: [ssaapp00]	Indicates the maximum number of TPS-TCs of each type that the VTU-O supports in the downstream direction: <ul style="list-style-type: none"> • ss=max number of downstream STM TPS-TCs (0,1,2); • aa=max number of downstream ATM TPS-TCs (0,1,2); and • pp=max number of downstream PTM TPS-TCs (0,1,2)
Maximum number of upstream TPS-TCs of each type	1 byte: [ssaapp00]	Indicates the maximum number of TPS-TCs of each type that the VTU-O supports in the upstream direction: <ul style="list-style-type: none"> • ss=max number of upstream STM TPS-TCs (0,1,2); • aa=max number of upstream ATM TPS-TCs (0,1,2); and • pp=max number of upstream PTM TPS-TCs (0,1,2)
Supported combinations of downstream bearer channels and TPS-TCs	1 byte: [s ₀ a ₀ p ₀ 0 s ₁ a ₁ p ₁ 0]	s ₀ : equal to 1 if STM can be supported on bearer channel 0 a ₀ : equal to 1 if ATM can be supported on bearer channel 0 p ₀ : equal to 1 if PTM can be supported on bearer channel 0 s ₁ : equal to 1 if STM can be supported on bearer channel 1 a ₁ : equal to 1 if ATM can be supported on bearer channel 1 p ₁ : equal to 1 if PTM can be supported on bearer channel 1
Supported combinations of upstream bearer channels and TPS-TCs	1 byte: [s ₀ a ₀ p ₀ 0 s ₁ a ₁ p ₁ 0]	s ₀ : equal to 1 if STM can be supported on bearer channel 0 a ₀ : equal to 1 if ATM can be supported on bearer channel 0 p ₀ : equal to 1 if PTM can be supported on bearer channel 0 s ₁ : equal to 1 if STM can be supported on bearer channel 1 a ₁ : equal to 1 if ATM can be supported on bearer channel 1 p ₁ : equal to 1 if PTM can be supported on bearer channel 1
For each supported TPS-TC, a bearer channel descriptor (see Table 12-51) shall be appended to the message.		
Downstream STM TPS-TC capabilities	0, 1, or 2 bearer channel descriptors	Contains the capabilities of the supported downstream STM TPS-TCs.
Downstream ATM TPS-TC capabilities	0, 1, or 2 bearer channel descriptors	Contains the capabilities of the supported downstream ATM TPS-TCs.
Downstream PTM TPS-TC capabilities	0, 1, or 2 bearer channel descriptors	Contains the capabilities of the supported downstream PTM TPS-TCs.
Upstream STM TPS-TC capabilities	0, 1, or 2 bearer channel descriptors	Contains the capabilities of the supported upstream STM TPS-TCs.
Upstream ATM TPS-TC capabilities	0, 1, or 2 bearer channel descriptors	Contains the capabilities of the supported upstream ATM TPS-TCs.
Upstream PTM TPS-TC capabilities	0, 1, or 2 bearer channel descriptors	Contains the capabilities of the supported upstream PTM TPS-TCs.
NOTE – The number of bearer channel descriptors for the TPS-TC capabilities depends on the fields "Maximum number of downstream/upstream TPS-TCs".		

Table 12-51 – Bearer channel descriptor

Octet	Content of field
1-2	Minimum net data rate (<i>net_min_n</i>)
3-4	Maximum net data rate (<i>net_max_n</i>)
5-6	Reserved net data rate (<i>net_reserve_n</i>) (Note)
7	Maximum interleaving delay
8	Impulse noise protection and dynamic interleaver reconfiguration
9	TPS-TC options
NOTE – This parameter is not used in this version of this Recommendation and shall be set to the value of the minimum net data rate in octets 1 and 2. The OLR procedures that utilize this parameter will be defined in a future revision of this Recommendation.	

In the fields "Minimum net data rate", "Maximum net data rate" and "Reserved net data rate", the parameter values for *net_min_n*, *net_max_n* and *net_reserve_n*, respectively, shall be coded as unsigned integers representing the data rate as a multiple of 8 kbit/s.

The fields "Maximum interleaving delay" and "Impulse noise protection" are not applicable in O-MSG 1 (which communicates capabilities), and the values of octets 7 and 8 in each bearer channel descriptor shall be ignored by the VTU-R receiver.

The field "TPS-TC options" shall contain one octet to negotiate and select the options for this bearer. The content depends on the type of TPS-TC mapped on this bearer.

For a bearer mapped to a PTM TPS-TC, the octet shall be coded as follows:

- Bit 0: If the VTU-O supports pre-emption in this bearer (N.3.1.2 of [ITU-T G.992.3]), the bit shall be set to ONE.
- Bit 1: If the VTU-O supports short packets in this bearer (N.3.1.3 of [ITU-T G.992.3]), the bit shall be set to ONE.
- Bits 2-7 are reserved by ITU-T and set to ZERO.

For a bearer mapped to an ATM or STM TPS-TC, the TPS-TC options field is reserved by the ITU-T and shall be set to 00₁₆.

Table 12-52 – PMS-TC capabilities of the VTU-O

Field name	Format	Description
Downstream OLR capabilities	1 byte [rrufdsii]	<p>Indicates the support of optional OLR mechanisms in the downstream direction.</p> <p>f = 0 if downstream framing reconfiguration (change of T_p, G_p and B_{p0}) is not supported, f = 1 otherwise (Note 1).</p> <p>d is reserved by ITU-T for future use and shall be set to ZERO.</p> <p>s = 0 if downstream SRA (change of L_p, b_i, g_i) is not supported, s = 1 otherwise.</p> <p>ii = 00 if interleaver reconfiguration (change of D_p) is not supported, ii = 01 if interleaver reconfiguration is supported on one downstream latency path, ii = 11 if interleaver reconfiguration is supported on both downstream latency paths (Note 2).</p> <p>ii = 10 is reserved by the ITU-T.</p> <p>u = 0 if downstream SOS is not supported, u = 1 otherwise (Notes 3, 4)</p> <p>rr = 00 indicates that the ROC in the downstream direction is not supported at the VTU-O.</p> <p>rr = 01 indicates that the ROC in the downstream direction is supported, but dual latency mode is not.</p> <p>rr = 11 indicates that both the ROC and dual latency mode shall be supported in the downstream direction, but only one of these can be enabled at a given time.</p> <p>rr = 10 is reserved by the ITU-T.</p>
Upstream OLR capabilities	1 byte [rrufdsii]	<p>Indicates the support of optional OLR mechanisms in the upstream direction.</p> <p>f = 0 if upstream framing reconfiguration (change in T_p, G_p and B_{p0}) is not supported, f = 1 otherwise (Note 1).</p> <p>d is reserved by ITU-T for future use and shall be set to ZERO.</p> <p>s = 0 if upstream SRA (change of L_p, b_i, g_i) is not supported, s = 1 otherwise.</p> <p>ii = 00 if interleaver reconfiguration (change of D_p) is not supported, ii = 01 if interleaver reconfiguration is supported on one upstream latency path, ii = 11 if interleaver reconfiguration is supported on both upstream latency paths (Note 2).</p> <p>ii = 10 is reserved by the ITU-T.</p> <p>u = 0 if upstream SOS is not supported, u = 1 otherwise (Notes 3, 4)</p> <p>rr = 00 indicates that the ROC in the upstream direction is not supported at the VTU-O.</p> <p>rr = 01 indicates that the ROC in the upstream direction is supported, but dual latency mode is not.</p> <p>rr = 11 indicates that both the ROC and dual latency mode shall be supported in the upstream direction, but only one of these can be enabled at a given time.</p> <p>rr = 10 is reserved by the ITU-T.</p>
Downstream message overhead data rate (Note 5)	1 byte	<p>Minimum message overhead data rate that is needed by the VTU-O in the downstream direction. The unsigned 8-bit value is the message overhead data rate divided by 1 000 bits per second minus 1 (covering the range 1 to 256 kbit/s).</p>

Table 12-52 – PMS-TC capabilities of the VTU-O

Field name	Format	Description
Upstream message overhead data rate (Note 5)	1 byte	Minimum message overhead data rate that is needed by the VTU-O in the upstream direction. The unsigned 8-bit value is the message overhead data rate divided by 1 000 bits per second minus 1 (covering the range 1 to 256 kbit/s).
Max DS net data rate for latency path 0	2 bytes	Parameter block of 2 octets that describes the maximum downstream net data rate supported in latency path #0. The unsigned 16-bit value is the net data rate divided by 8 000 bits per second.
Max US net data rate for latency path 0	2 bytes	Parameter block of 2 octets that describes the maximum upstream net data rate supported in latency path #0. The unsigned 16-bit value is the net data rate divided by 8 000 bits per second.
Max DS net data rate for latency path 1	2 bytes	Parameter block of 2 octets that describes the maximum downstream net data rate supported in latency path #1. The unsigned 16-bit value is the net data rate divided by 8 000 bits per second.
Max US net data rate for latency path 1	2 bytes	Parameter block of 2 octets that describes the maximum upstream net data rate supported in latency path #1. The unsigned 16-bit value is the net data rate divided by 8 000 bits per second.
DS $(1/S)_{max}$	1 byte	Parameter block of 1 octet that describes the maximum value of 1/S supported by the VTU-O in the downstream direction as defined in clause 9.5.5. The unsigned 8-bit value is coded as 1 to 64 in steps of 1.
US $(1/S)_{max}$	1 byte	Parameter block of 1 octet that describes the maximum value of 1/S supported by the VTU-O in the upstream direction as defined in clause 9.5.5. The unsigned 8-bit value is coded as 1 to 64 in steps of 1.
<p>NOTE 1 – If support for SOS is indicated, support for framing reconfiguration (change of T_p, G_p and B_{p0}) shall also be indicated.</p> <p>NOTE 2 – In the case of single latency mode (i.e., without the ROC), the values for latency path 1 shall be set to ZERO. In the case of single latency with ROC mode, the values for latency path 0 shall be set to ZERO.</p> <p>NOTE 3 – If downstream SOS is supported, support for interleaver depth reconfiguration in the downstream direction shall also be indicated. If upstream SOS is supported, support for interleaver depth reconfiguration in the upstream direction shall also be indicated.</p> <p>NOTE 4 – If support for SOS is indicated, support for SRA shall also be indicated.</p> <p>NOTE 5 – When the ROC is enabled, all overhead data shall be carried in latency path #0 (the ROC).</p>		

12.3.5.2.1.2 O-TPS

The O-TPS message conveys the TPS-TC configuration for both the upstream and the downstream directions. It is based on the capabilities that were indicated in O-MSG 1 and R-MSG 2. The full list of parameters carried by the O-TPS message is shown in Table 12-53.

Table 12-53 – Description of message O-TPS

	Field name	Format
1	Message descriptor	Message code
2	TPS-TC configuration	See Table 12-54
3	Maximum delay variation	See Table 12-55
4	ROC and SOS enable	1 byte
5	G.998.4 parameter field	Variable length
6	G.993.5 parameter field	Variable length
7	Time synchronization enable	1 byte
8	<i>attndr_method</i>	1 byte

Field #1 "Message descriptor" is a unique one-byte code that identifies the message. See Table 12-6 for a complete list of codes.

Field #2 "TPS-TC configuration" specifies the TPS-TC configuration in the upstream and downstream directions, and is structured as shown in Table 12-54.

Field #3 "Maximum delay variation" specifies the maximum delay variation for each active bearer channel in the downstream direction, and is structured as shown in Table 12-55.

Field #4 indicates whether the ROC and SOS are enabled. It is a one byte value [ssss rrrr].

The value rrrr shall be coded as follows:

- A value rrrr=0000 indicates that the ROC is not enabled in either upstream or downstream.
- A value rrrr=0001 indicates that the ROC is enabled in upstream but not in downstream.
- A value rrrr=0010 indicates that the ROC is enabled in downstream but not in upstream.
- A value rrrr=0011 indicates that the ROC is enabled in both upstream and downstream.

The value ssss shall be coded as follows:

- A value ssss=0000 indicates that SOS is not enabled.
- A value ssss=0001 indicates that SOS is enabled in upstream but not in downstream.
- A value ssss=0010 indicates that SOS is enabled in downstream but not in upstream.
- A value ssss=0011 indicates that SOS is enabled in both upstream and downstream.

The value of ssss shall be set in accordance with ITU-T G.997.1 parameters RA-MODEds and RA-MODEus and the OLR capabilities in O-MSG 1 and R-MSG 2.

Table 12-54 – TPS-TC configuration

Field name	Format	Description
Mapped configurations of downstream bearer channels and TPS-TC types (Note 1)	1 byte: [aaaa bbbb]	aaaa = TPS-TC type that is mapped to DS bearer channel 0 <ul style="list-style-type: none"> • aaaa=1000: STM-TC • aaaa=0100: ATM-TC • aaaa=0010: PTM-TC • aaaa =0000: inactive bearer channel bbbb = TPS-TC type that is mapped to DS bearer channel 1 <ul style="list-style-type: none"> • bbbb =1000: STM-TC • bbbb =0100: ATM-TC • bbbb =0010: PTM-TC • bbbb =0000: inactive bearer channel

Table 12-54 – TPS-TC configuration

Field name	Format	Description
Mapped configurations of upstream bearer channels and TPS-TC types (Note 1)	1 byte: [cccc dddd]	cccc = TPS-TC type that is mapped to US bearer channel 0 <ul style="list-style-type: none"> • cccc =1000: STM-TC • cccc =0100: ATM-TC • cccc =0010: PTM-TC • cccc =0000: inactive bearer channel dddd = TPS-TC type that is mapped to US bearer channel 1 <ul style="list-style-type: none"> • dddd =1000: STM-TC • dddd =0100: ATM-TC • dddd =0010: PTM-TC • dddd =0000: inactive bearer channel
Downstream rate adaptation ratio	1 byte	This field contains the rate adaptation ratio of downstream bearer channel 0 as specified in [ITU-T G.997.1]. This field shall be coded as an unsigned integer in the range from 0 to 100. A value of 100 means that the whole excess capacity is allocated to bearer channel 0.
For each active bearer channel in each direction, a bearer channel descriptor (see Table 12-51) shall be appended to the message:		
Downstream bearer channel 0 configuration	0, or 1 bearer channel descriptor	Contains the required configuration of the downstream bearer 0
Downstream bearer channel 1 configuration	0, or 1 bearer channel descriptor	Contains the required configuration of the downstream bearer 1
Upstream bearer channel 0 configuration	0, or 1 bearer channel descriptor	Contains the required configuration of the upstream bearer 0
Upstream bearer channel 1 configuration	0 or 1 bearer channel descriptor	Contains the required configuration of the upstream bearer 1
NOTE 1 – Some simultaneous mappings of TPS-TCs are invalid (see clause 8.1.3.1). NOTE 2 – The number of bearer channel descriptors for the bearer channel configurations depends on the number of active bearer channels in each direction.		

In each bearer channel descriptor, the fields "Minimum net data rate", "Maximum net data rate" and "Reserved net data rate" shall contain the values for net_min_n , net_max_n and $net_reserve_n$, respectively, selected by the VTU-O. Each shall be coded as an unsigned integer representing the data rate as a multiple of 8 kbit/s.

In the field "Maximum interleaving delay", the parameter $delay_max_n$ shall be coded as an unsigned integer expressing delay in ms as follows:

- The valid values are $0 \leq delay_max_n \leq 63$, and $delay_max_n = 255$.
- The value $delay_max_n = 1$ is a special value indicating that the interleaver depth D_p shall be set to $D_p = 1$, corresponding to the lowest possible delay.
- The value $delay_max_n = 0$ is a special value indicating that no bound on the maximum delay is being imposed.
- The value $delay_max_n = 255$ is a special value indicating an interleaving delay of 1 ms.

If the bearer channel is operated without physical layer retransmission as defined in [ITU-T G.998.4], then the field "Impulse noise protection and dynamic interleaver reconfiguration" shall be coded as follows:

- Bits 0-5 shall contain the required INP_{min_n} value expressed in DMT symbols.
- The valid values are $0 \leq INP_{min_n} \leq 16$.
- The value $INP_{min_n} = 0$ is a special value indicating that no minimum level of impulse noise protection is required.
- Bit 6 shall be set to 1 to indicate that the bearer should be mapped in a latency path that supports dynamic interleaver reconfiguration. When no latency paths support dynamic interleaver reconfiguration or when the bearer chooses not to use it, the value of this bit shall be ZERO.

NOTE 1 – For both upstream and downstream transmission, the number of bearer channels that set the value of bit 6 to ONE cannot be higher than the number of latency paths that support interleaver reconfiguration.

- Bit 7: $INP_{no_erasure_required}$ (see clause 9.6)
 - When set to ONE, it indicates that the VTU-R receiver shall set $INP_p = INP_{no_erasure_p}$.
 - When set to ZERO, it indicates that the VTU-R receiver is not required to set $INP_p = INP_{no_erasure_p}$.

If the bearer channel is operated with physical layer retransmission, as defined in [ITU-T G.998.4], then the field "Impulse noise protection and dynamic interleaver reconfiguration" shall be coded as follows:

- Bits 0-6 shall contain the required INP_{min_n} value expressed in DMT symbols.
- Bit 7 shall be reserved for use by ITU-T and shall be set to ZERO.

NOTE 2 – Improper setting of one or more of the following parameters – maximum net data rate, downstream maximum SNR margin, impulse noise protection, maximum interleaving delay (in $SNRM_MODE=1$), $TXREFVN$ (in $SNRM_MODE=2$ and $SNRM_MODE=4$), $RXREFVN$ (in $SNRM_MODE=3$ and $SNRM_MODE=4$), and $TXREFVNSF$ and $RXREFVNSF$ (in $SNRM_MODE=4$) can result in high levels of transmit power that can lead to high crosstalk experienced by DSLs on other pairs in the same binder. Specifically, high values of maximum net data rate, downstream maximum SNR margin, impulse noise protection, low values of maximum interleaving delay (in $SNRM_MODE=1$), and high values of $TXREFVN$ (in $SNRM_MODE=2$ and $SNRM_MODE=4$), $RXREFVN$ (in $SNRM_MODE=3$ and $SNRM_MODE=4$), and $TXREFVNSF$ and $RXREFVNSF$ (in $SNRM_MODE=4$) are of concern.

The field "TPS-TC options" shall be coded as follows:

- Bit 0: The bit shall be set to ONE to enable pre-emption in this bearer, if and only if the bit was set to ONE for this bearer in both O-MSG 1 and R-MSG 2.
- Bit 1: The bit shall be set to ONE to enable short packets in this bearer, if and only if the bit was set to ONE for this bearer in both O-MSG 1 and R-MSG 2.

For a bearer mapped to an ATM or STM TPS-TC, bits 0 and 1 of the TPS-TC options field are reserved by ITU-T and shall be set to ZERO.

For the upstream bearer channel(s), bits 2-7 shall be set to ZERO.

For the downstream bearer channel(s), bits 2-7 shall be coded as follows:

- Bits 3-2 contains the selection of the $CIpolicy$ that shall be used in the downstream direction. A value of 00_2 indicates that the mandatory $CIpolicy$ shall be used. A value of 01_2 indicates that the optional $CIpolicy$ 1 (see clause 12.3.7) shall be used. A value of 10_2 indicates that the optional $CIpolicy$ 2 (see clause 12.3.7) shall be used. The CO shall only select optional

CIpolicies for which the VTU-R has indicated support (see clause 12.3.5.2.2.1). A value different from 00₂ can only be selected if no more than one bearer channel is active.

- Bit 4 contains the selection of the Re-Initialization Policy that shall be used in the downstream direction for that bearer channel (*RIpolicy_{sn}*). A value of ZERO indicates that the mandatory Re-Initialization Policy 0 shall be used. A value of ONE indicates that the optional Re-Initialization Policy 1 (see clause 12.1.4) shall be used. The same value shall be indicated for all bearer channels. The CO shall only select optional Re-Initialization Policies for which the VTU-R has indicated support (see clause 12.3.5.2.2.1).
- Bits 5-7 are reserved by the ITU-T and shall be set to ZERO.

Table 12-55 – Maximum delay variation

Field name	Format	Description
For each active bearer channel in downstream direction, a maximum delay variation field shall be present in this message:		
Downstream bearer channel 0 DV_max	0, or 1 byte (Note)	Contains the required DV_max of the downstream bearer 0
Downstream bearer channel 1 DV_max	0, or 1 byte (Note)	Contains the required DV_max of the downstream bearer 1
NOTE – The number of bytes is 0 if the bearer is disabled and is 1 if the bearer is enabled.		

The fields "Downstream bearer channel 0 DV_max" and "Downstream bearer channel 1 DV_max" describe the maximum allowed value for the delay variation, and shall be coded as an unsigned integer equal to the DV_max divided by 0.1 ms.

- The valid values are $0 \leq DV_{max_n} \leq 25.4$;
- The value FF₁₆ is a special value indicating that no delay variation bound is imposed.

Field #5 is a variable length field consisting of an integer number of bytes. It is formatted as shown in Table 12-26.

Field #6 is a variable length field consisting of an integer number of bytes. It is formatted as shown in Table 12-26.

The actual data in the variable length fields 5 and 6 are beyond the scope of this Recommendation. For a correct interpretation at the receiver, support of either [ITU-T G.998.4] or [ITU-T G.993.5] or both is required. However, support of those Recommendations is not implied or required for compliance with Recommendation ITU-T G.993.2.

If the VTU-O does not support [ITU-T G.998.4], the ITU-T G.998.4 parameter field shall be a single byte with value 0.

If the VTU-O does not support [ITU-T G.993.5], the ITU-T G.993.5 parameter field shall be a single byte with value 0.

Field #7 "Time Synchronization enable" indicates whether time synchronization is enabled. The field shall be formatted as [0000 00b₁b₀]. The valid values are:

- If b₁b₀=00, time synchronization is not enabled.
- If b₁b₀=01, frequency synchronization with the PMD sampling clock being frequency locked to the ToD network clock is used for time synchronization.
- If b₁b₀=10, frequency synchronization via the processing of ToD phase difference values is used for time synchronization.
- b₁b₀=11 is reserved by ITU-T.

Field #8 describes which method shall be used for the calculation of ATTNDR in the downstream direction. The field shall be formatted as [0000 00mm].

The value mm=00_b, respectively 01_b, respectively 10_b indicates that the VTU-R shall calculate the downstream ATTNDR using *attndr_method* = 0, respectively 1, respectively 2, as defined in clause 11.4.1.1.7.1, respectively clause 11.4.1.1.7.2.

The value mm=11_b is reserved by the ITU-T.

12.3.5.2.1.3 O-PMS

The O-PMS message conveys the initial PMS-TC parameter settings that shall be used in the upstream direction during Showtime. It also specifies the portion of shared interleaver memory that the VTU-R can use to de-interleave the downstream data stream. The full list of parameters carried by the O-PMS message is shown in Table 12-56.

Table 12-56 – Description of message O-PMS

	Field name	Format
1	Message descriptor	Message code
2	MSGLP (Note 1)	1 byte
3	Mapping of bearer channels to latency paths	1 byte
4	B _{x0}	1 byte
5	B _{x1}	1 byte
6	LP ₀ (Note 2)	Latency path descriptor
7	LP ₁	Latency path descriptor
8	max_delay_octet _{DS,0}	3 bytes
9	max_delay_octet _{DS,1}	3 bytes
10	max_delay_octet _{US,0}	3 bytes
11	max_delay_octet _{US,1}	3 bytes
12	Upstream SOS tone groups	Band descriptor
13	Upstream ROC parameters	ROC descriptor
14	ITU-T G.998.4 parameter field	Variable length
15	ITU-T G.993.5 parameter field	Variable length
16	ATTNDR_max_delay_octets _{DS,p}	3 bytes
NOTE 1 – If the ROC is enabled, MSGLP shall be equal to 0.		
NOTE 2 – If the ROC is enabled, the framing parameters for latency path #0 shall be contained in the ROC descriptor.		

Field #1 "Message descriptor" is a unique one-byte code that identifies the message. See Table 12-6 for a complete list of codes.

Field #2 "MSGLP" is a one-byte field that indicates which latency path is selected for OH frames of Type 1 (which carries message overhead) in the upstream direction. The seven MSBs of the byte shall always be set to ZERO. The LSB shall be set to ZERO to indicate latency path #0 or ONE to indicate latency path #1.

Field #3 "Mapping of bearer channels to latency paths" is a one-byte field that indicates which bearer channels shall be carried in each of the upstream latency paths. The byte is denoted as [cccc dddd]. The bits cccc shall be set to 0000 if bearer channel #0 is to be carried in latency path #0, and to 0001 if bearer channel #0 is to be carried in latency path #1. The bits cccc shall be set to 1111 if the bearer channel #0 is disabled. The bits dddd indicate which latency path carries bearer channel #1 using the same encoding method as used for cccc.

Field #4 "B_{x0}" is a one-byte field that indicates the number of octets from bearer channel #0 that shall be transported in each MDF in the upstream direction. The value shall be either zero or the non-zero value from the set {B₀₀, B₁₀}.

Field #5 "B_{x1}" is a one-byte field that indicates the number of octets from bearer channel #1 that shall be transported in each MDF in the upstream direction. The value shall be either zero or the non-zero value from the set {B₀₁, B₁₁}.

Field #6 "LP₀" is a 10-byte field that contains the PMS-TC parameters for latency path #0 in the upstream direction. The "Latency path descriptor" format specified in Table 12-57 shall be used.

Field #7 "LP₁" is a 10-byte field that contains the PMS-TC parameters for latency path #1 in the upstream direction. The "Latency path descriptor" format specified in Table 12-57 shall be used. If latency path #1 is not used, all bytes of LP₁ shall be set to ZERO.

Field #8 "max_delay_octet_{DS,0}" is a 3-byte field that specifies the maximum value of delay_{octet}_{DS,0} (defined in clause 6.2.8), specified in bytes as an unsigned integer.

Field #9 "max_delay_octet_{DS,1}" is a 3-byte field that specifies the maximum value of delay_{octet}_{DS,1} (defined in clause 6.2.8), specified in bytes as an unsigned integer. If the value of this field is set to the special value FFFFFFFF₁₆, the Field #8 (max_delay_octet_{DS,0}) specifies the maximum value of (delay_{octet}_{DS,0} + delay_{octet}_{DS,1}) and the VTU-R shall autonomously partition the number of octets between both downstream latency paths. The value FFFFFFFF₁₆ is not allowed if the VTU intends to use interleaver reconfiguration in the downstream direction.

Field #10 "max_delay_octet_{US,0}" is a 3-byte field that specifies the maximum value of delay_{octet}_{US,0} (defined in clause 6.2.8), specified in bytes as an unsigned integer.

Field #11 "max_delay_octet_{US,1}" is a 3-byte field that specifies the maximum value of delay_{octet}_{US,1} (defined in clause 6.2.8), specified in bytes as an unsigned integer.

The values exchanged in Fields #8 to #11 shall be valid during initialization and showtime. In particular, interleaver reconfiguration in a given latency path shall not lead to an interleaver delay that exceeds the values exchanged in O-PMS for that latency path. Any OLR command that results in a delay value that is higher than the one exchanged during initialization shall be rejected.

Field #12 contains the start and stop frequencies of the SOS tone groups (as defined in clause 13.3) for the upstream direction. It shall be formatted as a band descriptor (see Table 12-22), with a maximum of 64 bands.

If SOS is not enabled in the upstream direction, the band descriptor shall contain zero bands (see Table 12-22) and shall be ignored by the receiver.

Field #13 specifies the parameters that define the ROC in the upstream direction. It is formatted as an ROC descriptor, as defined in Table 12-58.

If the ROC is not enabled in the upstream direction, the values in the ROC descriptor shall all be set to zero and shall be ignored by the receiver.

The latency path descriptor is described in Table 12-57. It contains the primary parameters of the framer, as specified in Table 9-8, and the interleaver settings for one latency path. All values are unsigned integers.

Table 12-57 – Latency path descriptor

Octet	Field	Format	Description
1	T	1 byte	The number of MDFs in an OH subframe for the latency path; $T = k \times M$, where k is an integer. The value of T shall not exceed 64.

Table 12-57 – Latency path descriptor

Octet	Field	Format	Description
2	G	1 byte	The total number of overhead octets in an OH subframe for the latency path; $1 \leq G \leq 32$.
3	F	1 byte	Number of OH frames in the OH superframe for the latency path. $1 \leq F \leq 255$.
4	M	1 byte	The number of MDFs in an RS codeword for the latency path. Only the values 1, 2, 4, 8, 16 are allowable.
5 and 6	L	2 bytes	Contains the value of L for the latency path.
7	R	1 byte	Contains the value of R for the latency path.
8	I	1 byte	Contains the value of I for the latency path.
9 and 10	D	2 bytes	Interleaver depth D for the latency path.

Table 12-58 – ROC descriptor

Octet	Field	Format	Description
1	T	1 byte	The number of MDFs in an OH subframe of the ROC. $T = k \times M$, where k is an integer. The value of T shall not exceed 64.
2	G	1 byte	The total number of overhead octets in an OH subframe of the ROC; The valid values of G are $1 \leq G \leq 32$.
3	F	1 byte	Number of OH frames in the OH superframe for the ROC. The value of F shall be 1.
4	M	1 byte	The number of MDFs in an RS codeword for the ROC. The valid values of M are 1, 2, 4, 8 and 16.
5 and 6	L	2 bytes	Contains the value of L for the ROC. The valid values of L are from 8 to 128 in multiples of 8.
7	R	1 byte	Contains the value of R for the ROC. The value of R shall be 16.
8	I	1 byte	Contains the value of I for the ROC. I shall be set to $I = M \times (G/T) + R$. The valid values of I are $32 \leq I \leq 66$.
9 and 10	D	2 bytes	Interleaver depth D for the ROC. The valid values of D are $1 \leq D \leq 20$.

Field #14 is a variable length field consisting of an integer number of bytes. It is formatted as shown in Table 12-26.

Field #15 is a variable length field consisting of an integer number of bytes. It is formatted as shown in Table 12-26.

The actual data in the variable length fields 14 and 15 are beyond the scope of this Recommendation. For a correct interpretation at the receiver, support of either [ITU-T G.998.4] or [ITU-T G.993.5] or both is required. However, support of those Recommendations is not implied or required for compliance with Recommendation ITU-T G.993.2.

If the VTU-O does not support [ITU-T G.998.4], the ITU-T G.998.4 parameter field shall be a single byte with value 0.

If the VTU-O does not support [ITU-T G.993.5], the ITU-T G.993.5 parameter field shall be a single byte with value 0.

Field #16 "ATTNDR_max_delay_octet_{DS,p}" is a 3-byte field that specifies the maximum of delay_{octet_{DS,p}} that the VTU-R shall assume in the calculation of ATTNDR in downstream, for the latency path carrying the single bearer channel (see clause 11.4.1.1.7.2). The ATTNDR_max_delay_octet_{DS,p} shall be specified in bytes as an unsigned integer.

12.3.5.2.1.4 O-PMD

The O-PMD message conveys the initial PMD parameter settings that shall be used in the upstream direction during showtime. The full list of parameters carried by the O-PMD message is shown in Table 12-59.

Table 12-59 – Description of message O-PMD

	Field name	Format
1	Message descriptor	Message code
2	Trellis	1 byte
3	Bits and gains table	$2 \times NSC_{us}$ bytes
4	Tone ordering table	$3 \times \lceil NSC_{us}/2 \rceil$ bytes coded as follows: <ul style="list-style-type: none"> • Bits 0-11: t_{2n-1} • Bits 12-23: t_{2n}
5	Initialization status	1 byte
6	ITU-T G.998.4 parameter field	Variable length
7	ITU-T G.993.5 parameter field	Variable length
NOTE – The $\lceil x \rceil$ notation represents rounding to the nearest greater integer.		

Field #1 "Message descriptor" is a unique one-byte code that identifies the message. See Table 12-6 for a complete list of codes.

Field #2 "Trellis" indicates whether trellis coding shall be used in the upstream direction (00₁₆ = trellis disabled, 01₁₆ = trellis enabled).

Field #3 "Bits and gains table" contains the b_i and g_i values for every subcarrier in MEDLEY_{us}. The b_i shall indicate the number of bits to be mapped by the VTU-R to the subcarrier i ; the g_i shall indicate the scale factor that shall be applied to subcarrier i , relative to the gain that was used for that subcarrier during the transmission of R-P-MEDLEY.

The b_i 's and g_i 's shall only be defined for subcarriers from the MEDLEY_{us} set (as indicated in R-PRM), and shall be sent in ascending order of subcarrier indices i .

Each b_i value shall be represented as an unsigned 4-bit integer. Each g_i value shall be represented as an unsigned 12-bit fixed-point quantity, with the binary point assumed just to the right of the third most significant bit. For example, a g_i with binary representation (MSB listed first) 001.01000000₂ would instruct the VTU-R to scale the constellation for subcarrier i by a gain of 1.25, so that the power of that subcarrier would be 1.94 dB higher than it was during R-P-MEDLEY.

Each pair of b_i and g_i values shall be mapped on a 16-bit field as follows: [b_Mbbb g_Mggg gggg gggg], where b_M and g_M are the MSBs of the b_i and g_i binary representations, respectively.

Field #4 "Tone ordering table" contains the tone ordering table t for the upstream direction. The tone ordering table contains the order in which the subcarriers shall be assigned bits in the upstream direction. The table shall include all subcarriers of the MEDLEY_{us} set and only these subcarriers. Each subcarrier index shall be represented as a 12-bit value. Pairs of subcarrier indices shall be mapped to a field of 3 bytes as shown in Table 12-59. For example, if the value of the n^{th} field is 400200₁₆, $t_{2n-1} = 200_{16} = 512$ and $t_{2n} = 400_{16} = 1\ 024$. If the number of subcarriers in the MEDLEY_{us} set is odd, the last 12 bits of the field shall be set to ZERO (and ignored by the receiver). The value

of the first index sent shall be equal to the index of the first entry in the tone ordering table (t_1 , see clause 10.3.1). The remaining indices shall be sent in increasing order of the tone ordering table t entries ($t_2, t_3, \dots t_{NSCus}$).

Field #5: indicates the "Initialization status".

If, within the constraints of the channel initialization policies defined in clause 12.3.7, the receiver is unable to select a set of configuration parameters, the "Initialization success/failure code" indicates the initialization failure cause as defined in [ITU-T G.997.1]. If, within the constraints of the channel initialization policies defined in clause 12.3.7, the receiver is able to select a set of configuration parameters, the "Initialization success/failure code" indicates the initialization success. Valid Initialization success/failure codes are as follows:

- 80₁₆: Initialization success;
- 81₁₆: Configuration error;
- 82₁₆: Configuration not feasible on line;
- 00₁₆: Feature not supported.

Other values are reserved by the ITU-T.

If an initialization success/failure code 81₁₆ or 82₁₆ is set:

- all values in Field #2 to 4 shall be set to 0; and
- the VTU-O shall return to L3 link state instead of L0 link state at the completion of the initialization procedures.

Field #6 is a variable length field consisting of an integer number of bytes. It is formatted as shown in Table 12-26.

Field #7 is a variable length field consisting of an integer number of bytes. It is formatted as shown in Table 12-26.

The actual data in the variable length fields 6 and 7 are beyond the scope of this Recommendation. For a correct interpretation at the receiver, support of either [ITU-T G.998.4] or [ITU-T G.993.5] or both is required. However, support of those Recommendations is not implied or required for compliance with Recommendation ITU-T G.993.2.

If the VTU-O does not support [ITU-T G.998.4], the ITU-T G.998.4 parameter field shall be a single byte with value 0.

If the VTU-O does not support [ITU-T G.993.5], the ITU-T G.993.5 parameter field shall be a single byte with value 0.

12.3.5.2.2 VTU-R messages sent during the channel analysis and exchange phase

12.3.5.2.2.1 R-MSG 2

The R-MSG 2 message conveys VTU-R information to the VTU-O. The full list of parameters carried by the R-MSG 2 message is shown in Table 12-60.

Table 12-60 – Description of message R-MSG 2

	Field name	Format
1	Message descriptor	Message code
2	TPS-TC capabilities	See Table 12-61
3	PMS-TC capabilities	See Table 12-62
4	Support of "Flexible OH frame type 2" upstream and INM_INPEQ_FORMATds	1 byte

Table 12-60 – Description of message R-MSG 2

	Field name	Format
5	SOS Multi-step activation downstream	1 byte
6	SOS Multi-step activation upstream	1 byte
7	G.998.4 parameter field	Variable length
8	G.993.5 parameter field	Variable length
9	Time Synchronization capability	1 byte
10	Time Synchronization Period (TSP)	1 byte
11	ATTNDR method capability	1 byte

Field #1 "Message descriptor" is a unique one-byte code that identifies the message. See Table 12-6 for a complete list of codes.

Field #2 "TPS-TC capabilities" indicates the TPS-TC capabilities of the VTU-R, as shown in Table 12-61.

Field #3 "PMS-TC capabilities" indicates the PMS-TC capabilities of the VTU-R. This includes the supported latency paths at the VTU-R (DS and US) and the capabilities per path (such as supported coding and interleaver parameters), as shown in Table 12-62.

Field #4 indicates the support by the VTU-R of the "Flexible OH Frame Type 2" in the upstream direction and the INM_INPEQ_FORMATs in the downstream direction. The field shall be formatted as [0000 00ba]. The VTU-R shall indicate support by setting, respectively, a=1 and b=1 in this field. Other bits shall be set to 0 and are reserved by ITU-T.

Field #5 indicates the capabilities of the VTU-R to execute the SOS request in one step or in multiple steps in the downstream direction. The field is formatted as [gggg 0000]. The first four MSBs [gggg] indicate the maximum number of tones (G_{SOS}) that can be executed in a single step in the downstream direction. The valid values are:

- [0000]: No limitation
- [0010]: $G_{SOS} = 256$ tones
- [0011]: $G_{SOS} = 512$ tones
- [0100]: $G_{SOS} = 1\ 024$ tones

If SOS is supported, value $G_{SOS} = 256$ tones is a mandatory capability. If the VTU supports a particular value of G_{SOS} , it shall support all smaller values of G_{SOS} (and values T_{SOS} associated with them, as presented in Table 13-4).

Each G_{SOS} has a value of T_{SOS} associated with it, where T_{SOS} is the time (in symbols) between the execution of two successive groups of tones (see clause 13.3).

If the CPE does not support SOS in the downstream direction, this field shall contain a value within the specified valid range. This value shall be ignored by the receiver.

Field #6 indicates the capabilities of the VTU-R to execute the SOS request in one step or in multiple steps in the upstream direction. The format of the field and the valid values shall be the same as for field #5.

If the CPE does not support SOS in the upstream direction, this field shall contain a value within the specified valid range. This value shall be ignored by the receiver.

Field #7 is a variable length field consisting of an integer number of bytes. It is formatted as shown in Table 12-26.

Field #8 is a variable length field consisting of an integer number of bytes. It is formatted as shown in Table 12-26.

The actual data in the variable length fields 7 and 8 are beyond the scope of this Recommendation. For a correct interpretation at the receiver, support of either [ITU-T G.998.4] or [ITU-T G.993.5] or both is required. However, support of those Recommendations is not implied or required for compliance with Recommendation ITU-T G.993.2.

If the VTU-R does not support [ITU-T G.998.4], the ITU-T G.998.4 parameter field shall be a single byte with value 0.

If the VTU-R does not support [ITU-T G.993.5], the ITU-T G.993.5 parameter field shall be a single byte with value 0.

Field #9 "Time Synchronization capability" indicates the time synchronization capability of the VTU-R. The field shall be coded as a single byte [0000 00pt], where:

- t=0 indicates that time synchronization is not supported.
- t=1 indicates that time synchronization is supported.
- p = 0 indicates that, if time synchronization is enabled, the ToD phase difference values shall be transported through the OH frame.
- p = 1 indicates that, if time synchronization is enabled, the ToD phase difference values shall be transported through the eoc.

NOTE – If time synchronization is not supported, then t=0 and the value of p and the contents of field #10 should be ignored by the VTU-O.

Field #10 indicates the Time Synchronization Period (*TSP*), defined as maximum increment in number of superframes of the t_1 instant number contained in two consecutive transmissions of the time synchronization eoc message. *TSP* is represented in one byte with valid values $n = 10 \dots 255$, indicating $TSP = 16 \times n$.

Field #11 indicates the ATTNDR method capability of the VTU-R in the downstream direction. The field shall be formatted as [0000 000m].

A value m=1 indicates the VTU-R supports the improved method as defined in clause 11.4.1.1.7.2.

A value m=0 indicates the VTU-R does not support the improved method, and therefore only supports the basic method as defined in clause 11.4.1.1.7.1.

Other bits shall be set to 0 and are reserved by ITU-T.

Table 12-61 – TPS-TC capabilities of VTU-R

Field name	Format	Description
Maximum number of downstream TPS-TCs of each type	1 byte: [ssaapp00]	Indicates the maximum number of TPS-TCs of each type that the VTU-R supports in the downstream direction: <ul style="list-style-type: none"> • ss=max number of downstream STM TPS-TCs (0,1,2); • aa=max number of downstream ATM TPS-TCs (0,1,2); and • pp=max number of downstream PTM TPS-TCs (0,1,2).
Maximum number of upstream TPS-TCs of each type	1 byte: [ssaapp00]	Indicates the maximum number of TPS-TCs of each type that the VTU-R supports in the upstream direction: <ul style="list-style-type: none"> • ss=max number of upstream STM TPS-TCs (0,1,2); • aa=max number of upstream ATM TPS-TCs (0,1,2); and • pp=max number of upstream PTM TPS-TCs (0,1,2).

Table 12-61 – TPS-TC capabilities of VTU-R

Field name	Format	Description
Supported combinations of downstream bearer channels and TPS-TCs	1 byte: [s ₀ a ₀ p ₀ 0 s ₁ a ₁ p ₁ 0]	s ₀ : equal to 1 if STM can be supported on bearer channel 0 a ₀ : equal to 1 if ATM can be supported on bearer channel 0 p ₀ : equal to 1 if PTM can be supported on bearer channel 0 s ₁ : equal to 1 if STM can be supported on bearer channel 1 a ₁ : equal to 1 if ATM can be supported on bearer channel 1 p ₁ : equal to 1 if PTM can be supported on bearer channel 1
Supported combinations of upstream bearer channels and TPS-TCs	1 byte: [s ₀ a ₀ p ₀ 0 s ₁ a ₁ p ₁ 0]	s ₀ : equal to 1 if STM can be supported on bearer channel 0 a ₀ : equal to 1 if ATM can be supported on bearer channel 0 p ₀ : equal to 1 if PTM can be supported on bearer channel 0 s ₁ : equal to 1 if STM can be supported on bearer channel 1 a ₁ : equal to 1 if ATM can be supported on bearer channel 1 p ₁ : equal to 1 if PTM can be supported on bearer channel 1
For each supported TPS-TC, a bearer channel descriptor (see Table 12-51) shall be appended to the message.		
Downstream STM TPS-TC capabilities	0, 1, or 2 bearer channel descriptors	Contains the capabilities of the supported downstream STM TPS-TCs.
Downstream ATM TPS-TC capabilities	0, 1, or 2 bearer channel descriptors	Contains the capabilities of the supported downstream ATM TPS-TCs.
Downstream PTM TPS-TC capabilities	0, 1, or 2 bearer channel descriptors	Contains the capabilities of the supported downstream PTM TPS-TCs.
Upstream STM TPS-TC capabilities	0, 1, or 2 bearer channel descriptors	Contains the capabilities of the supported upstream STM TPS-TCs.
Upstream ATM TPS-TC capabilities	0, 1, or 2 bearer channel descriptors	Contains the capabilities of the supported upstream ATM TPS-TCs.
Upstream PTM TPS-TC capabilities	0, 1, or 2 bearer channel descriptors	Contains the capabilities of the supported upstream PTM TPS-TCs.
NOTE – The number of bearer channel descriptors for the TPS-TC capabilities depends on the fields "Maximum number of downstream/upstream TPS-TCs".		

Each bearer channel descriptor (see Table 12-51) shall be coded as follows.

In the fields "Minimum net data rate", "Maximum net data rate" and "Reserved net data rate", the parameter values for *net_min_n*, *net_max_n* and *net_reserve_n*, respectively, shall be coded as unsigned integers representing the data rate as a multiple of 8 kbit/s.

The fields "Maximum interleaving delay" and "Impulse noise protection" are not applicable in R-MSG 2 (which communicates capabilities), and the values of octets 7 and 8 in each bearer channel descriptor shall be ignored by the VTU-O receiver.

The field "TPS-TC options" shall be coded as follows:

- Bit 0: If the VTU-R supports pre-emption in this bearer (N.3.1.2 of [ITU-T G.992.3]), the bit shall be set to ONE.
- Bit 1: If the VTU-R supports short packets in this bearer (N.3.1.3 of ITU-T [G.992.3]), the bit shall be set to ONE.

For a bearer mapped to an ATM or STM TPS-TC, bits 0 and 1 shall be set to ZERO at the transmitter and ignored by the receiver.

Bit 2 indicates whether the optional channel initialization policy 1 is supported for that bearer channel. This bit shall be set to ONE to indicate support for this policy.

Bit 3 indicates whether the optional channel initialization policy 2 is supported for that bearer channel. This bit shall be set to ONE to indicate support for this policy.

Bit 4 indicates whether the optional Re-Initialization Policy 1 (i.e., $RIpolicyds_n=1$) is supported (see clause 12.1.4) for that bearer channel. This bit shall be set to ONE to indicate support for this policy. This bit shall be set to the same value for all bearer channels.

Bits 5-7 are reserved by ITU-T and shall be set to ZERO.

Table 12-62 – PMS-TC capabilities of VTU-R

Field name	Format	Description
Downstream OLR capabilities	1 byte [rrufdsii]	<p>Indicates the support of optional OLR mechanisms in the downstream direction.</p> <p>f = 0 if downstream framing reconfiguration (change of T_p, G_p and B_{p0}) is not supported, f = 1 otherwise (Note 1).</p> <p>d is reserved by ITU-T for future use and shall be set to zero.</p> <p>s = 0 if downstream SRA (change of L_p, b_i, g_i) is not supported, s = 1 otherwise.</p> <p>ii = 00 if interleaver reconfiguration (change of D_p) is not supported, ii = 01 if interleaver reconfiguration is supported on one downstream latency path, ii = 11 if interleaver reconfiguration is supported on both downstream latency paths (Note 2).</p> <p>ii = 10 is reserved by the ITU-T.</p> <p>u = 0 if downstream SOS is not supported, u = 1 otherwise (Notes 3, 4)</p> <p>rr = 00 indicates that the ROC in the downstream direction is not supported at the VTU-R.</p> <p>rr = 01 indicates that the ROC in the downstream direction is supported, but dual latency mode is not.</p> <p>rr = 11 indicates that both the ROC and dual latency mode shall be supported in the downstream direction, but only one of these can be enabled at a given time.</p> <p>rr = 10 is reserved by the ITU-T.</p>

Table 12-62 – PMS-TC capabilities of VTU-R

Field name	Format	Description
Upstream OLR capabilities	1 byte [rrufdsii]	Indicates the support of optional OLR mechanisms in the upstream direction. f = 0 if upstream framing reconfiguration (change of T_p , G_p and B_{p0}) is not supported, f = 1 otherwise (Note 1). d is reserved by ITU-T for future use and shall be set to zero. s = 0 if upstream SRA (change of L_p , b_i , g_i) is not supported, s = 1 otherwise. ii = 00 if interleaver reconfiguration (change of D_p) is not supported, ii = 01 if interleaver reconfiguration is supported on one upstream latency path, ii = 11 if interleaver reconfiguration is supported on both upstream latency paths (Note 2). ii = 10 is reserved by the ITU-T. u = 0 if upstream SOS is not supported, u = 1 otherwise (Notes 3, 4) rr = 00 indicates that the ROC in the upstream direction is not supported at the VTU-R. rr = 01 indicates that the ROC in the upstream direction is supported, but dual latency mode is not. rr = 11 indicates that both the ROC and dual latency mode shall be supported in the upstream direction, but only one of these can be enabled at a given time. rr = 10 is reserved by the ITU-T.
Downstream message overhead data rate (Note 5)	1 byte	Minimum message overhead data rate that is needed by the VTU-R in the downstream direction. The unsigned 8-bit value is the message overhead data rate divided by 1 000 bits per second minus 1 (covering the range 1 to 256 kbit/s).
Upstream message overhead data rate (Note 5)	1 byte	Minimum message overhead data rate that is needed by the VTU-R in the upstream direction. The unsigned 8-bit value is the message overhead data rate divided by 1 000 bits per second minus 1 (covering the range 1 to 256 kbit/s).
Max DS net data rate for latency path 0	2 bytes	The maximum downstream net data rate supported in latency path #0. The unsigned 16-bit value is the net data rate divided by 8 000 bits per second.
Max US net data rate for latency path 0	2 bytes	The maximum upstream net data rate supported in latency path #0. The unsigned 16-bit value is the net data rate divided by 8 000 bits per second.
Max DS net data rate for latency path 1	2 bytes	Parameter block of 2 octets that describes the maximum downstream net data rate supported in latency path #1. The unsigned 16-bit value is the net data rate divided by 8 000 bits per second.
Max US net data rate for latency path 1	2 bytes	Parameter block of 2 octets that describes the maximum upstream net data rate supported in latency path #1. The unsigned 16-bit value is the net data rate divided by 8 000 bits per second.
DS $(1/S)_{max}$	1 byte	Parameter block of 1 octet that describes the maximum value of 1/S supported by the VTU-R in the downstream direction as defined in clause 9.5.5. The unsigned 8-bit value is coded as 1 to 64 in steps of 1.

Table 12-62 – PMS-TC capabilities of VTU-R

Field name	Format	Description
US (1/S) _{max}	1 byte	Parameter block of 1 octet that describes the maximum value of 1/S supported by the VTU-R in the upstream direction as defined in clause 9.5.5. The unsigned 8-bit value is coded as 1 to 64 in steps of 1.
<p>NOTE 1 – If support for SOS is indicated, support for framing reconfiguration (change of T_p, G_p and B_{p0}) shall also be indicated.</p> <p>NOTE 2 – In the case of single latency mode (i.e., without the ROC), the values for latency path 1 shall be set to ZERO. In the case of single latency with ROC mode, the values for latency path 0 shall be set to ZERO.</p> <p>NOTE 3 – If upstream SOS is supported, support for interleaver depth reconfiguration in the upstream direction shall also be indicated. If downstream SOS is supported, support for interleaver depth reconfiguration in the downstream direction shall also be indicated.</p> <p>NOTE 4 – If support for SOS is indicated, support for SRA shall also be indicated.</p> <p>NOTE 5 – When the ROC is enabled, all overhead data shall be carried in latency path #0 (the ROC).</p>		

12.3.5.2.2.2 R-TPS-ACK

R-TPS-ACK is a message that acknowledges correct reception of the O-TPS message. The content shall be as specified in Table 12-63.

Table 12-63 – Description of message R-TPS-ACK

	Field name	Format
1	Message descriptor	Message code
2	G.998.4 parameter field	Variable length
3	G.993.5 parameter field	Variable length

Field #1 "Message descriptor" is a unique one-byte code that identifies the message. See Table 12-6 for a complete list of codes.

Field #2 is a variable length field consisting of an integer number of bytes. It is formatted as shown in Table 12-26.

Field #3 is a variable length field consisting of an integer number of bytes. It is formatted as shown in Table 12-26.

The actual data in the variable length fields 2 and 3 are beyond the scope of this Recommendation. For a correct interpretation at the receiver, support of either [ITU-T G.998.4] or [ITU-T G.993.5] or both is required. However, support of those Recommendations is not implied or required for compliance with Recommendation ITU-T G.993.2.

If the VTU-R does not support [ITU-T G.998.4], the ITU-T G.998.4 parameter field shall be a single byte with value 0.

If the VTU-R does not support [ITU-T G.993.5], the ITU-T G.993.5 parameter field shall be a single byte with value 0.

12.3.5.2.2.3 R-PMS

The R-PMS message conveys the initial PMS-TC parameter settings that shall be used in the downstream direction during showtime. The full list of parameters carried by the R-PMS message is shown in Table 12-64.

Table 12-64 – Description of message R-PMS

	Field name	Format
1	Message descriptor	Message code
2	MSGLP (Note 1)	1 byte
3	Mapping of bearer channels to latency paths	1 byte
4	B _{x0}	1 byte
5	B _{x1}	1 byte
6	LP ₀ (Note 2)	Latency path descriptor
7	LP ₁	Latency path descriptor
8	Erasure decoding used	1 byte
9	Downstream SOS tone groups	Band descriptor
10	Downstream ROC parameters	ROC descriptor
11	ITU-T G.998.4 parameter field	Variable length
12	ITU-T G.993.5 parameter field	Variable length
NOTE 1 – If the ROC is enabled, MSGLP shall be equal to 0.		
NOTE 2 – If the ROC is enabled, the framing parameters for latency path #0 shall be contained in the ROC descriptor.		

Field #1 "Message descriptor" is a unique one-byte code that identifies the message. See Table 12-6 for a complete list of codes.

Field #2 "MSGLP" is a one-byte field that indicates which latency path is selected for OH frames of Type 1 (which carries message overhead) in the downstream direction. The seven MSBs of the byte shall always be set to ZERO. The LSB shall be set to ZERO to indicate latency path #0 or ONE to indicate latency path #1.

Field #3 "Mapping of bearer channels to latency paths" is a one-byte field that indicates which bearer channels shall be carried in each of the downstream latency paths. The byte is denoted as [cccc dddd]. The bits cccc shall be set to 0000 if bearer channel #0 is to be carried in latency path #0, and to 0001 if bearer channel #0 is to be carried in latency path #1. The bits cccc shall be set to 1111 if the bearer channel #0 is disabled. The bits dddd indicate which latency path carries bearer channel #1 using the same encoding method as used for cccc.

Field #4 "B_{x0}" is a one-byte field that indicates the number of octets from bearer channel #0 that shall be transported in each MDF in the downstream direction. The value shall be either zero or the non-zero value from the set {B₀₀, B₁₀}.

Field #5 "B_{x1}" is a one-byte field that indicates the number of octets from bearer channel #1 that shall be transported in each MDF in the downstream direction. The value shall be either zero or the non-zero value from the set {B₀₁, B₁₁}.

Field #6 "LP₀" is a 10-byte field that contains the PMS-TC parameters for latency path #0 in the downstream direction. The "Latency path descriptor" format specified in Table 12-57 shall be used.

Field #7 "LP₁" is a 10-byte field that contains the PMS-TC parameters for latency path #1 in the downstream direction. The "Latency path descriptor" format specified in Table 12-57 shall be used. If latency path #1 is not used, all bytes of LP₁ shall be set to ZERO.

Field #8 "Erasure decoding used" is a 1-byte field that indicates whether the VTU-R is using erasure decoding. The value shall be:

- 00₁₆ if erasure decoding is not used on any downstream latency path;
- 01₁₆ if erasure decoding is used on downstream latency path #0;

- 10_{16} if erasure decoding is used on downstream latency path #1; or
- 11_{16} if erasure decoding is used on both downstream latency paths.

Field #9 contains the start and stop frequencies of the SOS tone groups (as defined in clause 13.3) for the downstream direction. It shall be formatted as a band descriptor (see Table 12-22), with a maximum of 64 bands.

If SOS is not activated in the downstream direction, the band descriptor shall contain zero bands (see Table 12-22) and shall be ignored by the receiver.

Field #10 specifies the parameters that define the ROC in the downstream direction. It is formatted as an ROC descriptor, as defined in Table 12-58.

If the ROC is not enabled in the downstream direction, the values in the ROC descriptor shall all be set to zero and shall be ignored by the receiver.

Field #11 is a variable length field consisting of an integer number of bytes. It is formatted as shown in Table 12-26.

Field #12 is a variable length field consisting of an integer number of bytes. It is formatted as shown in Table 12-26.

The actual data in the variable length fields 11 and 12 are beyond the scope of this Recommendation. For a correct interpretation at the receiver, support of either [ITU-T G.998.4] or [ITU-T G.993.5] or both is required. However, support of those Recommendations is not implied or required for compliance with Recommendation ITU-T G.993.2.

If the VTU-R does not support [ITU-T G.998.4], the ITU-T G.998.4 parameter field shall be a single byte with value 0.

If the VTU-R does not support [ITU-T G.993.5], the ITU-T G.993.5 parameter field shall be a single byte with value 0.

12.3.5.2.2.4 R-PMD

The R-PMD message conveys the initial PMD parameter settings that shall be used in the downstream direction during showtime. The content of R-PMD is shown in Table 12-65.

Table 12-65 – Description of message R-PMD

	Field name	Format
1	Message descriptor	Message code
2	Trellis	1 byte
3	Bits and gains table	$2 \times N_{SC_{ds}}$ bytes
4	Tone ordering table	$3 \times \lceil N_{SC_{ds}}/2 \rceil$ bytes coded as follows: <ul style="list-style-type: none"> • Bits 0-11: t_{2n-1} • Bits 12-23: t_{2n}
5	Showtime pilot tones	Tone descriptor
6	Initialization status	1 byte
7	ITU-T G.998.4 parameter field	Variable length
8	ITU-T G.993.5 parameter field	Variable length
NOTE – The $\lceil x \rceil$ notation represents rounding to the nearest greater integer.		

Field #1 "Message descriptor" is a unique one-byte code that identifies the message. See Table 12-6 for a complete list of codes.

Field #2 "Trellis" indicates whether trellis coding shall be used in the downstream direction (00_{16} = trellis disabled, 01_{16} = trellis enabled).

Field #3 "Bits and gains table" contains the b_i and g_i values for every subcarrier in MEDLEYds. The b_i shall indicate the number of bits to be mapped by the VTU-O to the subcarrier i ; the g_i shall indicate the scale factor that shall be applied to subcarrier i , relative to the gain that was used for that subcarrier during the transmission of O-P-MEDLEY.

The b_i 's and g_i 's shall only be defined for subcarriers from the MEDLEYds set (as indicated in O-PRM), and shall be sent in ascending order of the subcarrier indices i .

Each b_i value shall be represented as an unsigned 4-bit integer. Each g_i value shall be represented as an unsigned 12-bit fixed-point quantity, with the binary point assumed just to the right of the third most significant bit. For example, a g_i with binary representation (MSB listed first) 001.01000000_2 would instruct the VTU-O to scale the constellation for subcarrier i by a gain of 1.25, so that the power of that subcarrier would be 1.94 dB higher than it was during O-P-MEDLEY.

Each pair of b_i and g_i values shall be mapped on a 16-bit field as follows: $[b_M b b b b \ g_M g g g g \ g g g g \ g g g g]$, where b_M and g_M are the MSBs of the b_i and g_i binary representations, respectively.

Field #4 "Tone ordering table" contains the tone ordering table t for the downstream direction. The tone ordering table contains the order in which the subcarriers shall be assigned bits in the downstream direction. The table shall include all subcarriers of the MEDLEYds set and only these subcarriers. Each subcarrier index shall be represented as a 12-bit value. Pairs of subcarrier indices shall be mapped to a field of 3 bytes as shown in Table 12-65. For example, if the value of the n^{th} field is 400200_{16} , $t_{2n-1} = 200_{16} = 512$ and $t_{2n} = 400_{16} = 1\ 024$. If the number of subcarriers in the MEDLEYds set is odd, the last 12 bits of the field shall be set to ZERO (and ignored by the receiver). The value of the first index sent shall be equal to the index of the first entry in the tone ordering table (t_1 , see clause 10.3.1). The remaining indices shall be sent in increasing order of the tone ordering table t entries ($t_2, t_3, \dots t_{NSCds}$).

Field #5 "Showtime pilot tones" indicates the selection of pilot tones that the VTU-R intends to use during showtime. The field shall be formatted as a tone descriptor, as shown in Table 12-33. The first octet of the tone descriptor shall contain the number of pilot tones selected by the VTU-R. If this number is zero, there shall be no further octets in the descriptor. If the number of tones is not equal to zero, each group of three consecutive octets in the descriptor shall describe the location (i.e., the subcarrier index) of two pilot tones. If the number of pilot tones is odd, the last 12 bits shall be ignored.

The VTU-R shall only select a tone as a pilot tone if the bit loading for that tone, as given in the bits and gains table (Field #3), is equal to zero. The showtime pilot tones shall be modulated as specified in clause 10.4.5.1. The total number of showtime pilot tones shall not exceed 16.

Field #6: indicates the "Initialization status".

If, within the constraints of the channel initialization policies defined in clause 12.3.7, the receiver is unable to select a set of configuration parameters, the "Initialization success/failure code" indicates the initialization failure cause as defined in [ITU-T G.997.1]. If, within the constraints of the channel initialization policies defined in clause 12.3.7, the receiver is able to select a set of configuration parameters, the "Initialization success/failure code" indicates the initialization success. Valid Initialization success/failure codes are as follows:

- 80_{16} : Initialization success;
- 81_{16} : Configuration error;
- 82_{16} : Configuration not feasible on line;
- 00_{16} : Feature not supported.

Other values are reserved by the ITU-T.

If an initialization success/failure code 81_{16} or 82_{16} is set:

- all values in Field #2 to 4 shall be set to 0; and
- the VTU-R shall return to L3 link state instead of L0 link state at the completion of the initialization procedures.

Field #7 is a variable length field consisting of an integer number of bytes. It is formatted as shown in Table 12-26.

Field #8 is a variable length field consisting of an integer number of bytes. It is formatted as shown in Table 12-26.

The actual data in the variable length fields 5 and 6 are beyond the scope of this Recommendation. For a correct interpretation at the receiver, support of either [ITU-T G.998.4] or [ITU-T G.993.5] or both is required. However, support of those Recommendations is not implied or required for compliance with Recommendation ITU-T G.993.2.

If the VTU-R does not support [ITU-T G.998.4], the ITU-T G.998.4 parameter field shall be a single byte with value 0.

If the VTU-R does not support [ITU-T G.993.5], the ITU-T G.993.5 parameter field shall be a single byte with value 0.

12.3.5.3 Signals transmitted during the channel analysis and exchange phase

All signals transmitted during the channel analysis and exchange phase shall use only subcarriers from the MEDLEY_{ds} set in the downstream direction and subcarriers from the MEDLEY_{us} set in the upstream direction.

The transmit PSD of downstream signals shall comply with the downstream MEDLEY reference PSD mask (MREFMASK_{ds}) that was established at the end of the channel discovery phase in both the passband and the stopbands. The values of $2N_{ds}$ and CE shall be those determined at the end of the channel discovery phase and communicated in Fields #7 and #4 in O-PRM, respectively. The values of β_{ds} and cyclic prefix length shall be as communicated in Field #6 and Field #5 of O-PRM, respectively.

The transmit PSD of all upstream signals shall comply with the upstream MEDLEY reference PSD mask (MREFMASK_{us}) that was established at the end of the channel discovery phase in both the passband and the stopbands. The values of $2N_{us}$ and CE shall be those determined at the end of the channel discovery phase and communicated in Field #6 of R-PRM and Field #4 in O-PRM, respectively. The values of β_{us} and cyclic prefix length shall be those communicated in Fields #5 and #4 of R-PRM, respectively.

12.3.5.3.1 Signals transmitted by the VTU-O

12.3.5.3.1.1 O-P-MEDLEY

O-P-MEDLEY is used by the VTU-R to estimate the downstream SNR and to communicate the SOC messages specified in clause 12.3.5.2.1. During transmission of O-P-MEDLEY, the SOC is in its active state.

The duration of O-P-MEDLEY is variable. The VTU-O terminates O-P-MEDLEY by transmitting O-P-SYNCHRO 6.

O-P-MEDLEY shall use all MEDLEY_{ds} subcarriers modulated by 4-QAM. O-P-MEDLEY shall carry either one byte ($b_7 b_6 \dots b_0$) or two bytes ($b_{15} b_{14} \dots b_0$) of information per DMT symbol. The bits shall be mapped to the subcarriers as described in Table 12-66 for two bytes per DMT symbol and in Table 12-67 for one byte per DMT symbol. The number of bytes per DMT symbol shall be the minimum of the values of $B_{ex-ds-O}$ and $B_{ex-ds-R}$ requested by the VTU-O and VTU-R in O-TA_UPDATE and R-TA_UPDATE, respectively.

The constellation points on all subcarriers shall be rotated based on the 2-bit number provided by the quadrant scrambler described in clause 12.3.6.2. The scrambler shall be used in free-running mode (see clause 12.3.6.2.2). The scrambler shall reset when the VTU-O enters the channel analysis and exchange phase.

Symbols shall be generated as described in clause 10.4.4. The symbol length shall be $2N_{ds}+L_{CE}$ samples. The overall window length shall be β_{ds} .

Table 12-66 – Bit mapping for O-P-MEDLEY with two bytes per DMT symbol

Subcarrier index	Constellation point
5, 10, 15, ..., $5n$, ...	00
1, 11, 21, ..., $10n+1$, ...	SOC message bits 0 and 1
2, 12, 22, ..., $10n+2$, ...	SOC message bits 2 and 3
3, 13, 23, ..., $10n+3$, ...	SOC message bits 4 and 5
4, 14, 24, ..., $10n+4$, ...	SOC message bits 6 and 7
6, 16, 26, ..., $10n+6$, ...	SOC message bits 8 and 9
7, 17, 27, ..., $10n+7$, ...	SOC message bits 10 and 11
8, 18, 28, ..., $10n+8$, ...	SOC message bits 12 and 13
9, 19, 29, ..., $10n+9$, ...	SOC message bits 14 and 15
NOTE – The byte is given as (b7, b6, b5, b4, b3, b2, b1, b0), where b7 is the MSB and b0 is the LSB. Mapping, e.g., "SOC message bits 0 and 1" to subcarriers $10n+1$ means that the two-bit value (b1, b0) shall be used to determine the constellation point in accordance with the encoding rules given in clause 10.3.3.2. This constellation point will then be scrambled using the quadrant scrambler described in clause 12.3.6.2.	

Table 12-67 – Bit mapping for O-P-MEDLEY with one byte per DMT symbol

Subcarrier index	Constellation point
Even	00
1, 11, 21, ..., $10n+1$, ...	SOC message bits 0 and 1
3, 13, 23, ..., $10n+3$, ...	SOC message bits 2 and 3
5, 15, 25, ..., $10n+5$, ...	SOC message bits 4 and 5
7, 17, 27, ..., $10n+7$, ...	SOC message bits 6 and 7
9, 19, 29, ..., $10n+9$, ...	00
NOTE – The byte is given as (b7, b6, b5, b4, b3, b2, b1, b0), where b7 is the MSB and b0 is the LSB. Mapping, e.g., "SOC message bits 0 and 1" to subcarriers $10n+1$ means that the two-bit value (b1,b0) shall be used to determine the constellation point in accordance with the encoding rules given in clause 10.3.3.2. This constellation point will then be scrambled using the quadrant scrambler described in clause 12.3.6.2.	

The transmit PSD of the MEDLEYds subcarriers in O-P-MEDLEY shall be equal to the downstream MEDLEY reference PSD (MREFPSDs) communicated in Field #2 of O-PRM.

12.3.5.3.1.2 O-P-SYNCHRO 6

O-P-SYNCHRO 6 is a signal that provides an exact time marker for the transition from O-P-MEDLEY to Showtime. During transmission of O-P-SYNCHRO 6, the SOC is in its inactive state.

The duration of O-P-SYNCHRO 6 is 15 DMT symbols.

O-P-SYNCHRO 6 shall use all subcarriers in the MEDLEYds set modulated by 4-QAM. The value 11 shall be mapped to all of the MEDLEYds subcarriers for the first 5 and the last 5 DMT symbols.

The value 00 shall be mapped to all of the MEDLEYds subcarriers for the middle 5 DMT symbols. The constellation points on all subcarriers shall be rotated based on the 2-bit number provided by the quadrant scrambler described in clause 12.3.6.2. The scrambler shall be used in reset mode (see clause 12.3.6.2.1).

Symbols shall be generated as described in clause 10.4.4. The symbol length shall be $2N_{ds}+L_{CE}$ samples. The overall window length shall be equal to β_{ds} .

The transmit PSD of the MEDLEYds subcarriers in O-P-SYNCHRO 6 shall be the same as for O-P-MEDLEY.

12.3.5.3.2 Signals transmitted by the VTU-R

12.3.5.3.2.1 R-P-MEDLEY

R-P-MEDLEY is used by the VTU-O to estimate the upstream SNR and to communicate the SOC messages specified in clause 12.3.5.2.2. During transmission of R-P-MEDLEY, the SOC is in its active state.

The duration of R-P-MEDLEY is variable. The VTU-R terminates R-P-MEDLEY by transmitting R-P-SYNCHRO 6.

R-P-MEDLEY shall use all MEDLEYus subcarriers modulated by 4-QAM. R-P-MEDLEY shall carry either one byte ($b_7 b_6 \dots b_0$) or two bytes ($b_{15} b_{14} \dots b_0$) of information per DMT symbol. The bits shall be mapped to subcarriers as described in Table 12-68 for two bytes per DMT symbol and in Table 12-69 for one byte per DMT symbol. The number of bytes per DMT symbol shall be the minimum of the values of $B_{ex-us-O}$ and $B_{ex-us-R}$ requested by the VTU-O and VTU-R in O-TA_UPDATE and R-TA_UPDATE, respectively.

The constellation points on all subcarriers shall be rotated based on the 2-bit number provided by the quadrant scrambler described in clause 12.3.6.2. The scrambler shall be used in free-running mode (see clause 12.3.6.2.2). The scrambler shall reset when the VTU-R enters the channel analysis and exchange phase.

Symbols shall be generated as described in clause 10.4.4. The symbol length shall be $2N_{us}+L_{CE}$ samples. The overall window length shall be β_{us} .

Table 12-68 – Bit mapping for R-P-MEDLEY with two bytes per DMT symbol

Subcarrier index	Constellation point
5, 10, 15, ..., $5n$, ...	00
1, 11, 21, ..., $10n+1$, ...	SOC message bits 0 and 1
2, 12, 22, ..., $10n+2$, ...	SOC message bits 2 and 3
3, 13, 23, ..., $10n+3$, ...	SOC message bits 4 and 5
4, 14, 24, ..., $10n+4$, ...	SOC message bits 6 and 7
6, 16, 26, ..., $10n+6$, ...	SOC message bits 8 and 9
7, 17, 27, ..., $10n+7$, ...	SOC message bits 10 and 11
8, 18, 28, ..., $10n+8$, ...	SOC message bits 12 and 13
9, 19, 29, ..., $10n+9$, ...	SOC message bits 14 and 15
NOTE – The byte is given as ($b_7, b_6, b_5, b_4, b_3, b_2, b_1, b_0$), where b_7 is the MSB and b_0 is the LSB. Mapping, e.g., "SOC message bits 0 and 1" to subcarriers $10n+1$ means that the two-bit value (b_1, b_0) shall be used to determine the constellation point in accordance with the encoding rules given in clause 10.3.3.2. This constellation point will then be scrambled using the quadrant scrambler described in clause 12.3.6.2.	

Table 12-69 – Bit mapping for R-P-MEDLEY with one byte per DMT symbol

Subcarrier index	Constellation point
Even	00
1, 11, 21, ..., $10n + 1$, ...	SOC message bits 0 and 1
3, 13, 23, ..., $10n + 3$, ...	SOC message bits 2 and 3
5, 15, 25, ..., $10n + 5$, ...	SOC message bits 4 and 5
7, 17, 27, ..., $10n + 7$, ...	SOC message bits 6 and 7
9, 19, 29, ..., $10n + 9$, ...	00
NOTE – The byte is given as (b7, b6, b5, b4, b3, b2, b1, b0), where b7 is the MSB and b0 is the LSB. Mapping, e.g., "SOC message bits 0 and 1" to subcarriers $10n+1$ means that the two-bit value (b1, b0) shall be used to determine the constellation point in accordance with the encoding rules given in clause 10.3.3.2. This constellation point will then be scrambled using the quadrant scrambler described in clause 12.3.6.2.	

The transmit PSD of the MEDLEY_{us} subcarriers in R-P-MEDLEY shall be equal to the upstream MEDLEY reference PSD (MREFPSD_{us}) communicated in the Field #2 of R-PRM.

12.3.5.3.2.2 R-P-SYNCHRO 6

R-P-SYNCHRO 6 is a signal that provides an exact time marker for the transition from R-P-MEDLEY to Showtime. During transmission of R-P-SYNCHRO 6, the SOC is in its inactive state.

The duration of R-P-SYNCHRO 6 is 15 DMT symbols.

R-P-SYNCHRO 6 shall use all subcarriers in the MEDLEY_{us} set modulated by 4-QAM. The value 11 shall be mapped to all of the MEDLEY_{us} subcarriers for the first 5 and the last 5 DMT symbols. The value 00 shall be mapped to all of the MEDLEY_{us} subcarriers for the middle 5 DMT symbols. The constellation points on all subcarriers shall be rotated based on the 2-bit number provided by the quadrant scrambler described in clause 12.3.6.2. The scrambler shall be used in reset mode (see clause 12.3.6.2.1).

Symbols shall be generated as described in clause 10.4.4. The symbol length shall be $2N_{us} + L_{CE}$ samples. The overall window length shall be equal to β_{us} .

The transmit PSD of the MEDLEY_{us} subcarriers in R-P-SYNCHRO 6 shall be the same as for R-P-MEDLEY.

12.3.6 General initialization signal requirements

12.3.6.1 Periodic signal requirements

The periodic signals used in initialization (O-P-PERIODIC 1, R-P-PERIODIC 1, and others) shall meet the requirements specified in this clause.

Implementers may choose to generate periodic signals using cyclically extended symbols or directly using the $2N$ samples out of the IDFT. The duration of each periodic signal shall be selected by a VTU such that it contains an integer number of cyclically extended symbols and an integer multiple of $2N$ samples. Specifically, $N_{\text{Sym_CE}} \times (2N + L_{CE}) = k \times 2N$, where $N_{\text{Sym_CE}}$ is the number of cyclically extended symbols needed to construct the periodic signal, and k is the number of periodic symbols in the periodic signal.

To ensure a smooth transition from an initialization signal with cyclically extended symbols to one that is periodic, the first symbol of each periodic signal shall be prepended by a cyclic prefix of β samples, where $\beta = \beta_{ds}$ for downstream signals and $\beta = \beta_{us}$ for upstream signals. These β samples shall be windowed and overlapped with the last β samples of the last symbol of the previous signal, as described in clause 10.4.4. Likewise, to ensure a smooth transition from a periodic signal to a signal

using cyclically extended symbols, the last β samples of the last symbol in the periodic signal shall be windowed and overlapped with the first β samples of the first symbol of the next signal.

12.3.6.2 Quadrant scrambler

The constellation point of each subcarrier shall be pseudo-randomly rotated by 0 , $\pi/2$, π or $3\pi/2$ depending on the value of a 2-bit pseudo-random number. The subcarrier with index 0 (DC) shall not be rotated. The rotation shall be implemented by transforming the (X, Y) coordinates of the constellation point as shown in Table 12-70, where X and Y are the coordinates before scrambling:

Table 12-70 – Pseudo-random transformation

d_{2n}, d_{2n+1}	Angle of rotation	Final coordinates
0 0	0	(X, Y)
0 1	$\pi/2$	$(-Y, X)$
1 1	π	$(-X, -Y)$
1 0	$3\pi/2$	$(Y, -X)$

The 2-bit values shown in the first column of Table 12-70 shall be the output of a PRBS generator defined by the equation:

$$d_n = d_{n-9} \oplus d_{n-11}$$

The bit generator is illustrated in Figure 12-12.

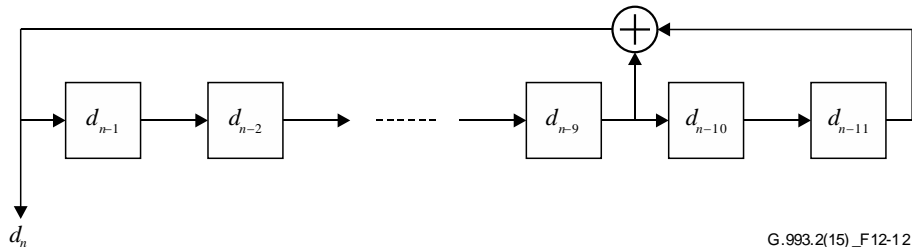

Figure 12-12 – Bit generator

Two bits from the scrambler shall be mapped to each subcarrier, including DC. The two bits corresponding to DC shall be overwritten with 00.

For a VDSL2 system that uses an IDFT size = $2N$, $2N$ bits shall be generated by the scrambler every DMT symbol ($b_0 b_1 b_2 \dots b_{2N-2} b_{2N-1}$) in each transmission direction. The first two bits ($b_0 b_1$) shall correspond to subcarrier 0, the next two bits ($b_2 b_3$) to subcarrier 1, and so on; bits ($b_{2i} b_{2i+1}$) shall correspond to subcarrier i . Bits shall be generated for all subcarriers, not just those being transmitted. Bits generated for subcarriers that are not in use shall be discarded.

At the beginning of initialization, all registers of the scrambler shall be set to ONE. Two modes of scrambler operation are used: reset mode and free-running mode.

12.3.6.2.1 Reset mode

In reset mode, the scrambler shall be reset at the beginning of every symbol period. Therefore, the same $2N$ bits will be generated for each symbol, and each subcarrier will be assigned the same two-bit pseudo-random number for rotation of its constellation point in successive symbols.

12.3.6.2.2 Free-running mode

In free-running mode, the scrambler shall not be reset at the beginning of each symbol period, but instead shall continue running from one symbol to the next. As a result, there should be no correlation between the two bits that are mapped on subcarrier i during symbol s and the two bits mapped to subcarrier i during symbol $s+1$. To guarantee that the bits on a particular subcarrier are uncorrelated from one DMT symbol to the next, for all values of IDFT size, four scrambler bits shall be skipped between symbols s and $s+1$. Practically, this means the scrambler generates $2N$ bits that are allocated to symbol s . The next four bits generated by the scrambler are not used. The next $2N$ bits from the scrambler are then allocated to symbol $s+1$.

12.3.7 Channel initialization policies

The method used by the receiver to select the values of transceiver parameters described in this clause is implementation dependent. However, within the limit of the total data rate provided by the local PMD, the selected values shall meet all of the constraints communicated by the transmitter prior to the channel analysis and exchange phase, including:

- Message overhead data rate \geq Minimum message overhead data rate;
- Net data rate \geq Minimum net data rate for all bearer channels;
- Impulse noise protection \geq Minimum impulse noise protection for all bearer channels;
- Delay \leq Maximum delay for all bearer channels;
- SNR Margin \geq TARSNRM.

Within those constraints, the receiver shall select the values as to optimize in the priority given in one of the priority lists below, where the selection of the list is configured through the CO-MIB channel initialization policy parameter (CIPOLICY, see clause 7.3.2.10 of [ITU-T G.997.1]). The channel initialization policy applies only for the selection of the values exchanged during initialization, and does not apply during showtime.

Due to use of the specific modulation pattern of O/R-P-MEDLEY signal (modulation with SOC bytes followed by a quadrant scrambler), after the VTU enters the SHOWTIME state, the reported SNRM value can be inaccurate and lower than the TARSNRM value.

If OLR type 3 (SRA) is supported and enabled, the VTU may initiate an SRA with vendor discretionary triggering criteria for a period of 10 seconds after the VTU has entered the SHOWTIME state in order to achieve a more accurate reported SNRM value greater than or equal to the TARSNRM value.

The following channel initialization policies are defined:

- Policy ZERO if $Cipolicy_n=0$, then:
 - 1) Maximize net data rate for all bearer channels, per the allocation of the net data rate, in excess of the sum of the minimum net data rates over all bearer channels (see clause 12.3.5).
 - 2) Minimize excess margin with respect to the maximum SNR margin (MAXSNRM) through gain adjustments (see clause 10.3.4.2). Other control parameters may be used to achieve this (e.g., MAXMASK, see clause 7.2.3).
- Policy ONE if $Cipolicy_n=1$, then:
 - a) If the minimum net data rate (see clause 7.3.2.1.1 of [ITU-T G.997.1]) is set equal to the maximum net data rate (see clause 7.3.2.1.3 of [ITU-T G.997.1]) then
 - 1) Maximize INP_act_n for bearer channel $\#n$.
 - b) If the minimum net data rate (see clause 7.3.2.1.1 of [ITU-T G.997.1]) is not set equal to the maximum net data rate (see clause 7.3.2.1.3 of [ITU-T G.997.1]) then

- 1) Maximize net data rate for all the bearer channels, per the allocation of the net data rate, in excess of the sum of the minimum net data rates over all bearer channels (see clause 12.3.5).
 - 2) If such maximized net data rate is equal to the maximum net data rate (see clause 7.3.2.1.3 of [ITU-T G.997.1]), maximize INP_{act_n} for the bearer channel $\#n$.
 - 3) Minimize excess margin with respect to the maximum noise margin MAXSNRM through gain scalings (see clause 10.3.4.2). Other control parameters may be used to achieve this (e.g., MAXMASK, see clause 7.2.3).
- Policy TWO if $Cipolicy_n = 2$, then:
 - 1) Maximize net data rate for all the bearer channels, per the allocation of the net data rate, in excess of the sum of the minimum net data rates over all bearer channels (see clause 12.3.5).
 - 2) If such maximized net data rate is equal to the maximum net data rate (see clause 7.3.2.1.3 of [ITU-T G.997.1]), maximize $SNRM_n$ for the bearer channel $\#n$.
 - 3) Minimize excess margin with respect to the maximum noise margin MAXSNRM through gain scalings (see clause 10.3.4.2). Other control parameters may be used to achieve this (e.g., MAXMASK, see clause 7.2.3).

If only a single bearer channel is configured through the CO-MIB, then the CIPOLICY shall be set to ZERO, ONE or TWO. If multiple bearer channels are configured through the CO-MIB, then the CIPOLICY shall be set to ZERO for each of the bearer channels. The use of the channel initialization policy ONE or TWO with multiple bearer channels is for further study.

Support of channel initialization policy ZERO is mandatory. Support of channel initialization policy ONE or TWO is optional. Additional channel initialization policies are for further study. The $Cipolicy_n$ parameter values other than 0, 1 and 2 are reserved for use by the ITU-T.

12.3.7.1 Channel initialization policies with ROC

The method used by the receiver to select the values of transceiver parameters described in this clause is implementation dependent. However, within the limit of the total data rate provided by the local PMD, the selected values shall meet all of the constraints communicated by the transmitter prior to the Channel Analysis and Exchange phase, including:

- Message overhead data rate \geq Minimum message overhead data rate.
- Net data rate \geq Minimum net data rate for all bearer channels.
- Impulse noise protection \geq Minimum impulse noise protection for all bearer channels.
- Delay \leq Maximum delay for all bearer channels.
- SNR Margin \geq TARSNRM.
- SNR Margin for the ROC \geq TARSNRM.

Within those constraints, the receiver shall select the values as to optimize in the priority given in one of the priority lists below, where the selection of the list is configured through the CO-MIB Channel Initialization Policy Parameter (CIPOLICY, see clause 7.3.2.10 of [ITU-T G.997.1]). The Channel Initialization Policy applies only for the selection of the values exchanged during initialization, and does not apply during SHOWTIME.

Due to use of the specific modulation pattern of O/R-P-MEDLEY signal (modulation with SOC bytes followed by a quadrant scrambler), after the VTU enters the SHOWTIME state, the reported SNRM-ROC value can be inaccurate and lower than the TARSNRM value.

If OLR type 3 (SRA) is supported and enabled, the VTU may initiate an SRA with vendor discretionary triggering criteria for a period of 10 seconds after the VTU has entered the SHOWTIME state in order to achieve a more accurate reported SNRM-ROC value greater than or equal to the

TARSNRM value, preferably up to TARSNRM-ROC, as defined in the Channel Initialization policy below.

The following Channel Initialization policy is defined:

- Policy ZERO if $CIpolicy_n=0$, then:
 - 1) Maximize the SNR Margin for the ROC up to TARSNRM-ROC.
 - 2) Maximize net data rate for all bearer channels, per the allocation of the net data rate, in excess of the sum of the minimum net data rates over all bearer channels (see clause 12.3.5).
 - 3) Maximize the SNR Margin for the ROC above TARSNRM-ROC.
 - 4) Minimize excess margin with respect to the maximum SNR margin MAXSNRM through gain adjustments (see clause 10.3.4.2). Other control parameters may be used to achieve this (e.g., MAXMASK, see clause 7.2.3).

Support of Channel Initialization Policy ZERO is mandatory. Additional Channel Initialization Policies are for further study. The $CIpolicy_n$ parameter values other than 0 are reserved for use by the ITU-T.

12.4 Loop diagnostic mode procedures

12.4.1 Overview

The built-in loop diagnostic function defined in this clause enables the immediate measurement of channel conditions at both ends of the loop without dispatching maintenance technicians to attach test equipment to the loop. The resulting information helps to isolate the location (inside the premises, near the customer end of the loop, or near the network end of the loop) and the sources (crosstalk, radio frequency interference, and bridged taps) of impairments.

The loop diagnostic mode shall be entered after completion of the ITU-T G.994.1 Handshake phase, when the loop diagnostic mode codepoint in the MS message is set (see clauses 12.3.2.1.2 and 12.3.2.2.2). Loop diagnostic mode shall be entered upon request by either VTU. Both VTUs shall support the loop diagnostic mode.

The sequence of stages in the loop diagnostic mode shall be the same as for initialization (defined in clause 12.3) up to the channel analysis and exchange phase, where the test parameters listed in Table 12-71 and defined in clause 11.4.1 are exchanged. However, the test parameters for the quiet line noise (QLN) and the channel characteristics function (Hlog) shall be measured and exchanged during the channel discovery phase, as described in clause 12.4.3.

The time-outs specified in clause 12.3.1 do not apply to loop diagnostic mode. Time-out values are for further study.

Table 12-71 – Test parameters exchanged during the loop diagnostic mode

Abbreviation	Name
$Hlin(k \times G \times \Delta f)$	Channel characteristics per subcarrier group, linear
$Hlog(k \times G \times \Delta f)$	Channel characteristics per subcarrier group, \log_{10}
$QLN(k \times G \times \Delta f)$	Quiet line noise per subcarrier group
$SNR(k \times G \times \Delta f)$	Signal-to-noise ratio per subcarrier group
LATN-pb	Loop attenuation per band
SATN-pb	Signal attenuation per band
SNRM-pb	Signal-to-noise ratio margin per band
ATTNDR	Attainable net data rate
ACTATP	Actual aggregate transmit power (far end)

The test parameters are mapped to messages using an integer number of octets per parameter value. In case the parameter value as defined in clause 11.4.1 is represented by a number of bits that is not an integer number of octets, the parameter value shall be mapped to the LSBs of the message octets. Unused more significant bits shall be set to ZERO for unsigned parameter values and shall be set to the sign bit for signed parameter values.

12.4.1.1 SOC message mapping during loop diagnostic mode

In order to increase the robustness of the messages exchanged during the channel discovery and training phases of the loop diagnostic mode, all SOC messages shall be sent using 1 information bit per DMT symbol, where each bit is sent 5 times in 5 consecutive DMT symbols. The mapping of the SOC bits to subcarriers during loop diagnostic mode shall be as summarized in Table 12-72.

Table 12-72 – Bit mapping during loop diagnostic mode

Subcarrier index	Constellation bits for SOC bit = 0	Constellation bits for SOC bit = 1
Even	00	00
1, 11, 21, ..., 10n+1, ...	00	11
3, 13, 23, ..., 10n+3, ...	00	11
5, 15, 25, ..., 10n+5, ...	00	11
7, 17, 27, ..., 10n+7, ...	00	11
9, 19, 29, ..., 10n+9, ...	00	00

When the SOC is inactive, the symbols shall be transmitted as described in clause 12.3.3 without modification.

12.4.2 Channel discovery and training phases of loop diagnostic mode

12.4.2.1 SOC messages exchanged during the channel discovery and training phases of loop diagnostic mode

Other than O-PRM and R-PRM, the SOC messages for the channel discovery phase and the training phase of the loop diagnostic mode shall be the same as for the initialization procedure described in clauses 12.3.3 and 12.3.4, respectively. The test parameters for the quiet line noise (QLN) and the channel characteristics function (Hlog) shall be measured and exchanged during the channel discovery phase in the O-PRM-LD and R-PRM-LD messages, which replace O-PRM and R-PRM. The test parameters are listed in Table 12-73 and defined in clause 11.4.1.

Table 12-73 – Test parameters exchanged during the channel discovery phase in loop diagnostic mode

Abbreviation	Name
$Hlog(k \times G \times \Delta f)$	Channel characteristics per subcarrier group, dB
$QLN(k \times G \times \Delta f)$	Quiet line noise per subcarrier group, dBm/Hz

12.4.2.1.1 VTU-O message O-PRM-LD

Table 12-74 – Description of message O-PRM-LD

	Field name	Format
1	Message descriptor	Message code
2	Downstream MEDLEY reference PSD (MREFPSDs)	PSD descriptor
3	MEDLEYds set	Bands descriptor
4	Cyclic extension length	1 byte
5	Downstream cyclic prefix length	2 bytes
6	Downstream transmit window length (β_{ds})	1 byte
7	VTU-O IDFT size	1 byte
8	Duration of the VTU-O EC training period	1 byte
9	Requested duration of the VTU-O TEQ training period	1 byte
10	Requested duration of the VTU-R TEQ training period	1 byte
11	Requested minimum duration of the periodic signal	1 byte
12	Downstream frequency-domain spectrum shaping	Log_tss _i descriptor
13	Quiet line noise per subcarrier group, $QLN(k \times G \times \Delta f)$	512 bytes
14	Channel characteristics function Hlog per subcarrier group, $Hlog(k \times G \times \Delta f)$	2 × 512 bytes

Fields #1 to #12 shall be formatted the same as O-PRM (see clause 12.3.3.2.1.3).

Field #13 "Quiet line noise per subcarrier group, $QLN(k \times G \times \Delta f)$ " indicates the parameter QLN for 512 subcarrier groups in the upstream direction (measured at the VTU-O receiver). The parameter QLN for each group shall be represented as an 8-bit value as specified in clause 11.4.1.1.2, mapped to a single octet. The octets representing QLN values for different groups shall be mapped to Field #13 so that they are transmitted in ascending order of group index k , for $k = 0$ to 511. The groups shall be formed as specified in clause 11.4.1.

Field #14 "Channel characteristics function Hlog per subcarrier, $Hlog(k \times G \times \Delta f)$ " indicates the parameter $Hlog$ for 512 subcarrier groups in the upstream direction. The parameter $Hlog$ for each group shall be represented as a 10-bit value as specified in clause 11.4.1.1.1, mapped to 2 octets by adding six MSBs equal to 0. The pairs of octets representing $Hlog$ values for different groups shall be mapped to Field #14 so that they are transmitted in ascending order of group index k , for $k = 0$ to 511. The groups shall be formed as specified in clause 11.4.1.

12.4.2.1.2 VTU-R message R-PRM-LD

Table 12-75 – Description of message R-PRM-LD

	Field name	Format
1	Message descriptor	Message code
2	Upstream MEDLEY reference PSD (MREFPSD _{us})	PSD descriptor
3	MEDLEY _{us} set	Bands descriptor
4	Upstream cyclic prefix length	2 bytes
5	Upstream transmit window length (β_{us})	1 byte
6	VTU-R IDFT size	1 byte
7	Duration of the VTU-R EC training period	1 byte
8	Requested duration of the VTU-R TEQ training period	1 byte
9	Requested duration of the VTU-O TEQ training period	1 byte
10	Requested minimum duration of the periodic signal	1 byte
11	Minimum duration of the R-P-TRAINING 1 signal ($T_{\text{MIN-R-P-Train}}$)	1 byte
12	Upstream frequency-domain shaping	Log_tss; descriptor
13	Quiet line noise per subcarrier, $QLN(k \times G \times \Delta f)$	512 bytes
14	Channel characteristics function Hlog per subcarrier, $Hlog(k \times G \times \Delta f)$	2×512 bytes

Fields #1 to #12 shall be formatted the same as R-PRM (see clause 12.3.3.2.2.3).

Field #13 "Quiet line noise per subcarrier group, $QLN(k \times G \times \Delta f)$ " indicates the parameter QLN for 512 subcarrier groups in the downstream direction (measured at the VTU-R receiver). The parameter QLN for each group shall be represented as an 8-bit value as specified in clause 11.4.1.1.2, mapped into a single octet. The octets representing QLN values for different groups shall be mapped to Field #13 so that they are transmitted in ascending order of group index k , for $k = 0$ to 511. The groups shall be formed as specified in clause 11.4.1.

Field #14 "Channel characteristics function Hlog per subcarrier, $Hlog(k \times G \times \Delta f)$ " indicates the parameter $Hlog$ for 512 subcarrier groups in the downstream direction. The parameter $Hlog$ for each group shall be represented as a 10-bit value as specified in clause 11.4.1.1.1, mapped into 2 octets by adding six MSBs equal to 0. The pairs of octets representing $Hlog$ values for different groups shall be mapped to Field #14 so that they are transmitted in ascending order of group index k , for $k = 0$ to 511. The groups shall be formed as specified in clause 11.4.1.

12.4.2.2 Signals transmitted during the channel discovery and training phases

The signals transmitted during the channel discovery and training phases are the same as defined in initialization (see clauses 12.3.3 and 12.3.4) with the following exceptions:

- The SOC message mapping shall be as defined in clause 12.4.1.1;
- The duration of O-P-QUIET 1 shall be at least 8 192 symbols but not longer than 16 384 symbols.

12.4.3 Channel analysis and exchange phase of loop diagnostic mode

Figure 12-13 presents the timing diagram for the stages of the channel analysis and exchange phase of the loop diagnostic mode. It gives an overview of the sequence of signals transmitted and the sequence of SOC messages sent by the VTU-O and VTU-R during the channel analysis and exchange

phase of the loop diagnostic mode. The shaded areas correspond to periods of time when the SOC is in its inactive state.

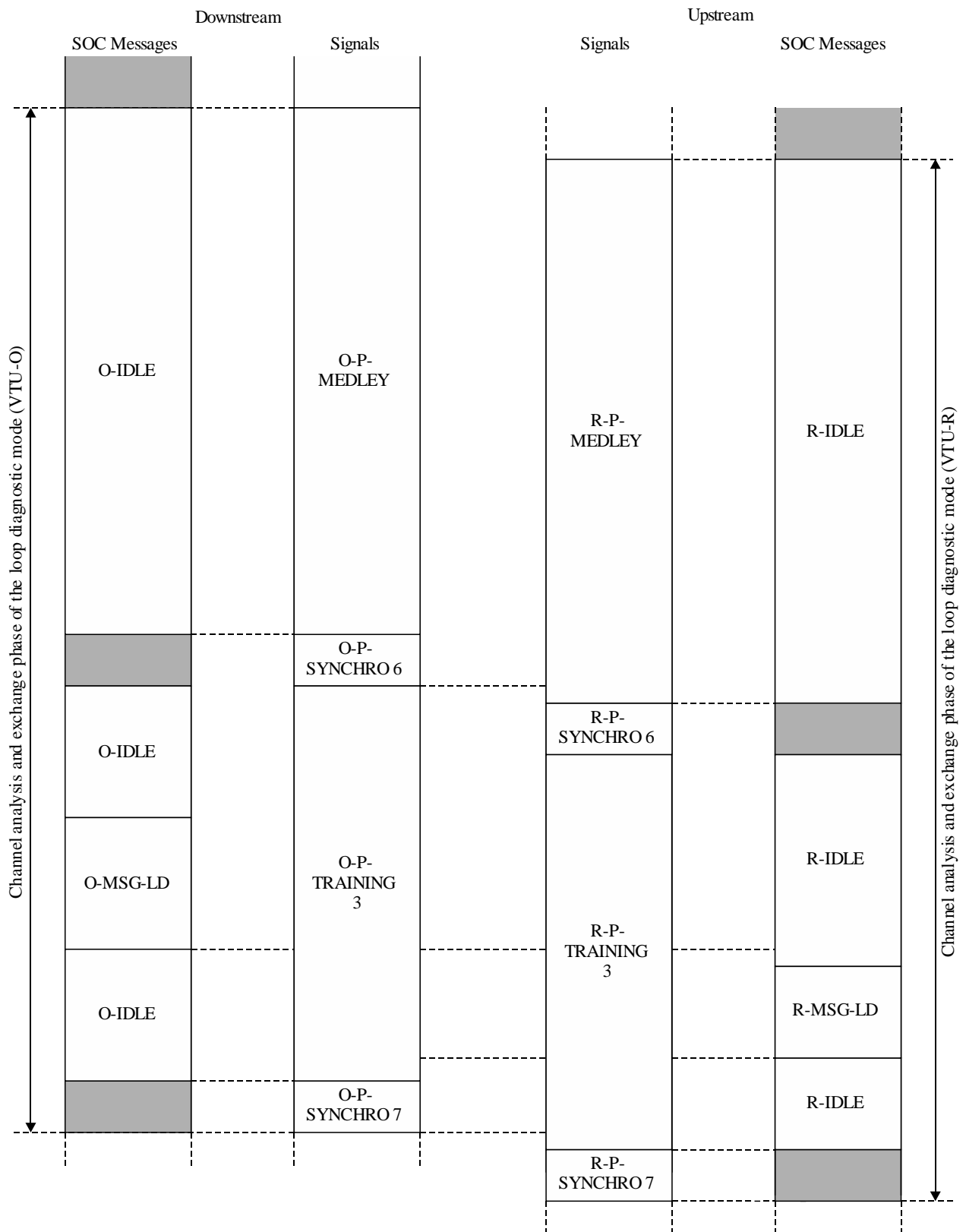

G.993.2(15)_F12-13

Figure 12-13 – Timing diagram for the stages of the channel analysis and exchange phase of the loop diagnostic mode

Upon entering this phase the VTU-O shall transmit 80 000 DMT symbols of O-P-MEDLEY with O-IDLE being sent over the SOC. Upon entering this phase the VTU-R shall transmit 80 000 DMT symbols of R-P-MEDLEY with R-IDLE being sent over the SOC.

O-P-MEDLEY and R-P-MEDLEY shall be followed by O-P-SYNCHRO 6 and R-P-SYNCHRO 6, respectively. O-P-SYNCHRO 6 and R-P-SYNCHRO 6 shall be as defined in clause 12.3.5.3.

After transmitting O-P-SYNCHRO 6, the VTU-O shall transmit O-P-TRAINING 3. While transmitting O-P-TRAINING 3, the VTU-O shall send O-IDLE over the SOC for at least 256 DMT symbols, and shall then send O-MSG-LD. Similarly, after transmitting R-P-SYNCHRO 6, the VTU-R shall transmit R-P-TRAINING 3. While transmitting R-P-TRAINING 3, the VTU-R shall send R-IDLE over the SOC. The VTU-R shall acknowledge the reception of O-MSG-LD by sending R-MSG-LD. Both VTUs shall use the RQ mode, as specified in clause 12.2.2.2.

The VTU-O shall acknowledge the reception of R-MSG-LD by transmitting O-P-SYNCHRO 7, which also indicates that the VTU-O has completed the channel analysis and exchange phase. The VTU-R acknowledges O-P-SYNCHRO 7 by transmitting R-P-SYNCHRO 7, indicating full completion of the loop diagnostic mode.

Table 12-76 – VTU-O signals and SOC messages in the channel analysis and exchange phase of loop diagnostic mode

Signal	Signal type	Signal duration in DMT symbols with CE	SOC messages and IDLE flags	SOC state
O-P-MEDLEY	Non-periodic	80 000	O-IDLE	Active
O-P-SYNCHRO 6	Non-periodic	15	None	Inactive
O-P-TRAINING 3	Non-periodic	Variable	O-MSG-LD	Active (RQ)
O-P-SYNCHRO 7	Non-periodic	15	None	Inactive

Table 12-77 – VTU-R signals and SOC messages during the channel analysis and exchange phase of loop diagnostic mode

Signal	Signal type	Signal duration in DMT symbols with CE	SOC messages and IDLE flags	SOC state
R-P-MEDLEY	Non-periodic	80 000	R-IDLE	Active
R-P-SYNCHRO 6	Non-periodic	15	None	Inactive
R-P-TRAINING 3	Non-periodic	Variable	R-MSG-LD	Active (RQ)
R-P-SYNCHRO 7	Non-periodic	15	None	Inactive

12.4.3.1 SOC messages exchanged during the channel analysis and exchange phase of loop diagnostic mode

12.4.3.1.1 VTU-O messages

In the loop diagnostic mode, the VTU-O shall send the O-MSG-LD message containing the upstream test parameters defined in clause 11.4.1.

The information fields of O-MSG-LD shall be as shown in Table 12-78.

Table 12-78 – Description of message O-MSG-LD

	Field name	Format
1	Message descriptor	Message code
2	$Hlin(k \times G \times \Delta f)$	6×512
3	$SNR(k \times G \times \Delta f)$	512
4	LATN-pb	(2×5) bytes
5	SATN-pb	(2×5) bytes
6	SNRM and SNRM-pb	$2 + (2 \times 5)$ bytes
7	ATTNDR	4 bytes
8	ACTATP	2 bytes

Field #1 "Message descriptor" is a unique one-byte code that identifies the message. See Table 12-6 for a complete list of codes.

Field #2 " $Hlin(k \times G \times \Delta f)$ " indicates the parameter Hlin for 512 subcarrier groups in the upstream direction. The parameter Hlin for each group shall be mapped to 6 octets as $[scale\ a(k)\ b(k)]$, where *scale*, *a(k)*, and *b(k)* are 16-bit values as specified in clause 11.4.1.1.1. The 6 octets representing Hlin values for different groups shall be mapped to Field #2 so that they are transmitted in ascending order of group index *k*, for $k = 0$ to 511. The groups shall be formed as specified in clause 11.4.1.

Field #3 " $SNR(k \times G \times \Delta f)$ " indicates the parameter SNR for 512 subcarrier groups in the upstream direction. The SNR for each group shall be represented as an 8-bit value as specified in clause 11.4.1.1.3, and mapped into 1 octet. The octets representing SNR values for different groups shall be mapped to Field #3 so that they are transmitted in ascending order of group index *k*, for $k = 0$ to 511. The groups shall be formed as specified in clause 11.4.1. The values of SNR for the groups containing at least one subcarrier that is not in the MEDLEY_{us} set shall be set to FF₁₆.

Field #4 "LATN-pb" shall indicate the parameter LATN_U(*m*) for each of 5 potentially available upstream bands. The parameter LATN_U(*m*) for each band shall be represented as a 10-bit value as specified in clause 11.4.1.1.4, and mapped into 2 octets by adding six MSBs equal to 0. The pairs of octets representing LATN_U(*m*) values for different bands shall be mapped to Field #4 as described in Table 11-29. The value 0000₁₆ shall be used to indicate disabled bands. Octets indicated as reserved in Table 11-29 shall be set to ZERO in the transmitter and ignored by the receiver.

Field #5 "SATN-pb" shall indicate the parameter SATN_U(*m*) for each of 5 potentially available upstream bands. The parameter SATN_U(*m*) for each band shall be represented as a 10-bit value as specified in clause 11.4.1.1.5, and mapped into 2 octets by adding six MSBs equal to 0. The pairs of octets representing SATN_U(*m*) values for different bands shall be mapped to Field #5 as described in Table 11-29. The value 0000₁₆ shall be used to indicate disabled bands. Octets indicated as reserved in Table 11-29 shall be set to ZERO in the transmitter and ignored by the receiver.

Field #6 "SNRM and SNRM-pb" shall indicate the overall upstream SNRM value, as specified in clause 11.4.1.1.6.2, and parameter SNRM_U(*m*), as specified in clause 11.4.1.1.6.3. The first two octets shall indicate parameter SNRM and the rest of the octets shall indicate parameter SNRM_U(*m*) for each of 5 potentially available upstream bands. The value of SNRM shall be represented as a 10-bit value as specified in clause 11.4.1.1.6.2. The parameter SNRM_U(*m*) for each band shall be represented as a 10-bit value as specified in clause 11.4.1.1.6.3. Both SNRM and SNRM_U(*m*) shall be mapped into 2 octets by adding six MSBs equal to the sign bit of the SNRM or SNRM_U(*m*) 10-bit representations, respectively. The pairs of octets representing SNRM_U(*m*) values for different bands shall be mapped to Field #6 as described in Table 11-29. The value 0000₁₆ shall be used to indicate disabled bands. Octets indicated as reserved in Table 11-29 shall be set to ZERO in the transmitter and ignored by the receiver.

Field #7 "ATTNDR" shall indicate the parameter ATTNDR in the upstream direction computed as specified in clause 11.4.1.1.7 for all subcarriers from the MEDLEY_{us} set. The parameter shall be represented as a 32-bit value as defined in clause 11.4.1.1.7.

Field #8 "ACTATP" shall indicate the parameter ACTATP in the upstream direction computed as specified in clause 11.4.1.1.8 for all subcarriers from the MEDLEY_{us} set. The parameter shall be represented as a 10-bit value as defined in clause 11.4.1.1.8 and mapped to the 2-byte Field #8 by adding six MSBs equal to the sign bit of the ACTATP representation.

12.4.3.1.2 VTU-R messages

In the loop diagnostic mode, the VTU-R shall send the R-MSG-LD message containing the downstream test parameters defined in clause 11.4.1.

The information fields of R-MSG-LD shall be as shown in Table 12-79.

Table 12-79 – Description of message R-MSG-LD

	Field name	Format
1	Message descriptor	Message code
2	$Hlin(k \times G \times \Delta f)$	6×512
3	$SNR(k \times G \times \Delta f)$	512
4	LATN-pb	(2×5) bytes
5	SATN-pb	(2×5) bytes
6	SNRM and SNRM-pb	$2 + (2 \times 5)$ bytes
7	ATTNDR	4 bytes
8	ACTATP	2 bytes

Field #1 "Message descriptor" is a unique one-byte code that identifies the message. See Table 12-6 for a complete list of codes.

Field #2 " $Hlin(k \times G \times \Delta f)$ " indicates the parameter Hlin for 512 subcarrier groups in the downstream direction. The parameter Hlin for each group shall be mapped into 6 octets as $[scale \ a(k) \ b(k)]$, where *scale*, *a(k)*, and *b(k)* are 16-bit values as specified in clause 11.4.1.1.1. The 6 octets representing Hlin values for different groups shall be mapped to Field #2 so that they are transmitted in ascending order of group index *k*, for *k* = 0 to 511. The groups shall be formed as specified in clause 11.4.1.

Field #3 " $SNR(k \times G \times \Delta f)$ " indicates the parameter SNR for 512 subcarrier groups in the downstream direction. The SNR for each group shall be represented as an 8-bit value as specified in clause 11.4.1.1.3, and mapped into a single octet. The octets representing SNR values for different groups shall be mapped to Field #3 so that they are transmitted in ascending order of group index *k*, for *k* = 0 to 511. The groups shall be formed as specified in clause 11.4.1. The values of SNR for the groups containing at least one subcarrier that is not in MEDLEY_{ds} set shall be set to FF₁₆.

Field #4 "LATN-pb" shall indicate the parameter LATN_D(*m*) for each of 5 potentially available downstream bands. The parameter LATN_D(*m*) for each band shall be represented as a 10-bit value as specified in clause 11.4.1.1.4, and mapped into 2 octets by adding six MSBs equal to 0. The pairs of octets representing LATN_D(*m*) values for different bands shall be mapped to Field #4 as described in Table 11-29. The value 0000₁₆ shall be used to indicate the disabled bands. Octets indicated as reserved in Table 11-29 shall be set to ZERO in the transmitter and ignored by the receiver.

Field #5 "SATN-pb" shall indicate the parameter SATN_D(*m*) for each of 5 potentially available downstream bands. The parameter SATN_D(*m*) for each band shall be represented as a 10-bit value as specified in clause 11.4.1.1.5, and mapped into 2 octets by adding six MSBs equal to 0. The pairs

of octets representing $SATN_D(m)$ values for different bands shall be mapped to Field #5 as described in Table 11-29. The value 0000_{16} shall be used to indicate the disabled bands. Octets indicated as reserved in Table 11-29 shall be set to ZERO in the transmitter and ignored by the receiver.

Field #6 "SNRM and SNRM-pb" shall indicate the overall downstream SNRM value, as specified in clause 11.4.1.1.6.2, and the parameter $SNRM_D(m)$, as specified in clause 11.4.1.1.6.3. The first two octets shall indicate parameter SNRM, and the rest of the octets shall indicate parameter $SNRM_D(m)$ for each of 5 potentially available downstream bands. The value of SNRM shall be represented as a 10-bit value as specified in clause 11.4.1.1.6.2. The value of $SNRM_D(m)$ for each band shall be represented as a 10-bit value as specified in clause 11.4.1.1.6.3. Both SNRM and $SNRM_D(m)$ shall be mapped into 2 octets by adding six MSBs equal to the sign bit of the SNRM and $SNRM_D(m)$ 10-bit representation, respectively. The pairs of octets representing $SNRM_D(m)$ values for different bands shall be mapped to Field #6 as described in Table 11-29. The value 0000_{16} shall be used to indicate the disabled bands. Octets indicated as reserved in Table 11-29 shall be set to ZERO in the transmitter and ignored by the receiver.

Field #7 "ATTNDR" shall indicate the parameter ATTNDR in the downstream direction computed as specified in clause 11.4.1.1.7 for all subcarriers from the MEDLEYds set. The parameter shall be represented as a 32-bit value as defined in clause 11.4.1.1.7.

Field #8 "ACTATP" shall indicate the parameter ACTATP in the downstream direction computed as specified in clause 11.4.1.1.8 for all subcarriers from the MEDLEYds set. The parameter shall be represented as a 10-bit value as defined in clause 11.4.1.1.8 and mapped into the 2-byte Field #8 by adding six MSBs equal to the sign bit of the ACTATP representation.

12.4.3.2 Signals transmitted during the channel analysis and exchange phase of loop diagnostic mode

The O-P-MEDLEY and R-P-MEDLEY signals shall be as defined in clause 12.3.5.3 for initialization with the following exceptions:

- the duration of O-P-MEDLEY and R-P-MEDLEY shall each be 80 000 symbols; and
- the SOC message mapping shall be as defined in clause 12.4.1.1.

O-P-SYNCHRO 6, R-P-SYNCHRO 6, O-P-SYNCHRO 7 and R-P-SYNCHRO 7 shall be as defined in clause 12.3.5.3 for initialization.

12.4.3.2.1 O-P-TRAINING 3

The O-P-TRAINING 3 signal is used to send the O-MSG-LD SOC message. During transmission of O-P-TRAINING 3, the SOC is in its active state.

The duration of O-P-TRAINING 3 is variable. The VTU-O terminates O-P-TRAINING 3 by transmitting O-P-SYNCHRO 7.

O-P-TRAINING 3 shall be composed of all subcarriers in the MEDLEYds set. These subcarriers shall be modulated by 4-QAM with SOC bit mapping as described in clause 12.4.1.1.

The constellation points of all subcarriers shall be rotated based on the 2-bit number provided by the quadrant scrambler described in clause 12.3.6.2. The scrambler shall be used in reset mode (see clause 12.3.6.2.1).

The symbol length shall be $2N_{ds} + L_{CE}$ samples. Windowing shall be applied at the transmitter, and the overall window length shall be equal to β_{ds} (see clause 10.4.4). The values of $2N_{ds}$, L_{CE} , β_{ds} and cyclic prefix length shall be set to the values communicated by the VTU-O in O-PRM-LD.

The transmit PSD of the MEDLEYds subcarriers in O-P-TRAINING 3 shall be the same as for O-P-TRAINING 2.

12.4.3.2.2 R-P-TRAINING 3

The R-P-TRAINING 3 signal is used to send the R-MSG-LD SOC message. During transmission of R-P-TRAINING 3, the SOC is in its active state.

The duration of R-P-TRAINING 3 is variable. The VTU-O terminates R-P-TRAINING 3 by transmitting R-P-SYNCHRO 7.

R-P-TRAINING 3 shall be composed of all subcarriers in the MEDLEYus set. These subcarriers shall be modulated by 4-QAM with SOC bit mapping as described in clause 12.4.1.1.

The constellation points of all subcarriers shall be rotated based on the 2-bit number provided by the quadrant scrambler, as described in clause 12.3.6.2. The scrambler shall be used in reset mode (see clause 12.3.6.2.1).

The symbol length shall be $2N_{us}+L_{CE}$ samples. Windowing shall be applied at the transmitter, and the overall window length shall be equal to β_{us} (see clause 10.4.4). The values of $2N_{us}$, β_{us} and cyclic prefix length shall be set to the values communicated by the VTU-R in R-PRM-LD. The value of L_{CE} shall be as communicated by the VTU-O in O-PRM-LD.

The transmit PSD of the MEDLEYus subcarriers in R-P-TRAINING 3 shall be the same as for R-P-TRAINING 2.

12.5 Fast start-up

For further study.

13 On-line reconfiguration (OLR)

On-line reconfiguration allows changes to the PMD without interruption of service and without errors. The defined procedures for on-line reconfiguration of the PMD function provide means for adapting to slowly varying channel conditions. They provide transparency to the PMS-TC, TPS-TC and higher layers by providing means for configuration parameter changes that introduce no transport errors, no latency changes, and no interruption of service.

13.1 Types of on-line reconfiguration

Types of OLR include bit swapping, seamless rate adaptation (SRA), and SOS.

Bit swapping reallocates bits and power (i.e., margin) among the allowed subcarriers without modification of the higher layer features of the physical layer. Bit swapping reconfigures the bit and gain (b_i , g_i) parameters without changing any other PMD or PMS-TC control parameters. After a bit swapping reconfiguration, the total data rate ($\sum L_p$) $\times f_s$ is unchanged, and the total data rate on each latency path ($L_p \times f_s$) is unchanged.

Because bit swapping is used autonomously to maintain the operating conditions of the VTU during changing environment conditions, bit swapping is a mandatory capability. The procedure for bit swapping is defined in clause 11.2.3.3 (OLR commands) and shall be implemented using Type 1 OLR messages as shown in Tables 11-5 and 11-6.

NOTE – When the ROC is enabled, bits L_0 and L_1 do not share the same subcarrier (see clause 10.3.1).

Seamless rate adaptation (SRA) is used to reconfigure the total data rate ($\sum L_p$) by modifying the framing parameters (L_p) and modifications to the bits and fine gains (b_i , g_i) parameters. Since the total data rate is modified, at least one latency path (or more) will have a new data rate (L_p) after the SRA. Since SRA is optional, the ability to support it is identified during the initialization procedure. The procedure for SRA is defined in clause 11.2.3.3 (OLR commands) and shall be implemented using Type 3 OLR messages as shown in Tables 11-6 and 11-7.

Save our Showtime (SOS) provides the receiver with a means to rapidly perform a bit loading reduction in a specified part of the frequency spectrum. This can be used in case of sudden noise increases. During initialization, the VTUs may define a number of SOS tone groups in both the upstream and downstream directions. An SOS request reduces the bit loading on all tones in a group by the same number of bits (multiple groups can be changed in a single command). The SOS request can also explicitly reconfigure the framing parameters L_p and the interleaver depth D_p in each of the latency paths.

NOTE 1 – For a wideband sudden noise increase, it is a goal that VTUs improve the data transmission within 1 second after the SOS trigger to achieve a $BER \leq 1E-7$. The desired data rate after this time is at least 80% of the data rate that would be obtained if the VTU were to (re-) initialize in the high noise condition using the same Transmit PSD level.

NOTE 2 – Sudden noise increases of up to 30 dB may occur in real networks.

Interleaver reconfiguration (within SRA) allows to dynamically change the interleaver depth D_p on one or more latency paths. SRA may be accompanied by a change of the framing parameters T_p , G_p and B_{p0} . Interleaver reconfiguration and modification of framing parameters T_p , G_p and B_{p0} are optional.

The procedure for interleaver reconfiguration is defined in clauses 9.4.1 and 11.2.3.3 (OLR commands) and shall be implemented using Type 3 OLR messages as shown in Tables 11-6 and 11-7.

13.2 Control parameters

13.2.1 Control parameters controlled by the OLR procedures

On-line reconfiguration of the PMD is accomplished by a coordinated change to the bits and gain values on two or more subcarriers. The bit and gain parameters described in Table 13-1 may be changed through on-line reconfiguration within the limits described.

Table 13-1 – Reconfigurable control parameters of the PMD function

Parameter	Definition
b_i	The number of bits per subcarrier with valid values all integers in the [0 ... 15] range. A change of the b_i values may be performed without modifying the L value (e.g., bit swap) or with a change of the L value (e.g., seamless rate adaptation).
g_i	The subcarrier gain adjustments with valid values in the [-14.5 ... +2.5] dB range.

The receiver shall support all valid b_i values and shall support increment and decrement of b_i values in steps of 1 bit in the OLR procedures. Incrementing or decrementing by steps larger than 1 bit are optional.

NOTE – The support of $b_i = 0$ is mandatory for the receiver in order to meet the requirement of 10^{-7} bit error ratio specified in clause 9.8.

The transmitter shall support of all valid values of b_i and shall support increment and decrement of b_i values in any step in the OLR procedures.

The updated bits and gains table shall comply with the bits and gains table requirements listed in clauses 10.3.1 and 10.3.4.

On-line reconfiguration of the PMS-TC is accomplished by a coordinated change to the value of one or more of the framing parameters shown in Table 13-2. The framing parameters displayed in Table 13-2 may be changed through on-line reconfiguration within the limits described.

Table 13-2 – Reconfigurable framing parameters of the PMS-TC function

Parameter	Definition
L_p	If latency path # p is used, the number of bits from latency path # p transmitted in each DMT symbol may be increased or decreased; the value of L_p is determined by the total data rate assigned for the latency path.
D_p	The interleaver depth on latency path p may be increased or decreased, as long as the resulting interleaver delay on that latency path does not exceed the bounds determined during initialization.
T_p	The number of MDFs in an overhead subframe: This value can be increased or decreased within the set of valid values (see Table 9-8).
G_p	The total number of overhead octets in an OH subframe: This value can be increased or decreased within the set of valid values (see Table 9-8).
B_{p0}	The total number of octets from bearer channel #0 in a mux data frame: This value can be increased or decreased within the set of valid values (see Table 9-8).
NOTE – Any change in L_p , T_p , G_p , and B_{p0} values shall be such that the length of the MDF (as defined in Table 9-8) remains unchanged for all active latency paths.	

13.2.2 Parameters controlling the OLR procedures

The list of parameters controlling OLR procedure Type 3 is presented in Table 13-3.

Table 13-3 – Control parameters controlling the OLR procedures

Parameter	Definition
<i>RA-USNRM</i> <i>RA-UTIME</i>	<p>The rate adaptation upshift noise margin and time interval (defined in [ITU-T G.997.1]). The parameter can be different for the VTU-O (<i>RA-USNRM_{us}</i> and <i>RA-UTIME_{us}</i>) and the VTU-R (<i>RA-UTIME_{ds}</i>, <i>RA-USNRM_{ds}</i>).</p> <p>VTU-O: Configured through CO-MIB. VTU-R: Configured through CO-MIB and communicated to the VTU-R during initialization (O-MSG 1).</p> <p>The valid values for <i>RA-USNRM_{us}</i> and <i>RA-USNRM_{ds}</i> are values between 0 and 31.0 dB in steps of 0.1 dB. The valid values for <i>RA-UTIME_{us}</i> and <i>RA-UTIME_{ds}</i> are values between 0 and 16 383 s in steps of 1 s.</p>
<i>RA-DSNRM</i> <i>RA-DTIME</i>	<p>The rate adaptation downshift noise margin and time interval (defined in [ITU-T G.997.1]). The parameter can be different for the VTU-O (<i>RA-DSNRM_{us}</i> and <i>RA-DTIME_{us}</i>) and the VTU-R (<i>RA-DTIME_{ds}</i>, <i>RA-DSNRM_{ds}</i>).</p> <p>VTU-O: Configured through the CO-MIB. VTU-R: Configured through the CO-MIB and communicated to the VTU-R during initialization (O-MSG 1).</p> <p>The valid values for <i>RA-DSNRM_{us}</i> and <i>RA-DSNRM_{ds}</i> are values between 0 and 31.0 dB in steps of 0.1 dB. The valid values for <i>RA-DTIME_{us}</i> and <i>RA-DTIME_{ds}</i> are values between 0 to 16 383 s in steps of 1 s.</p>

Table 13-3 – Control parameters controlling the OLR procedures

Parameter	Definition
DV_{max_n}	<p>The maximum allowed value for the delay variation DV_n of bearer channel $\#n$. It ranges from 0.1 to 25.4 in steps of 0.1 ms.</p> <p>The value 25.5 indicates that no delay variation bound is imposed.</p> <p>The parameter can be different for the VTU-O and the VTU-R.</p> <p>VTU-O: Configured through the CO-MIB.</p> <p>VTU-R: Configured through the CO-MIB and communicated to the VTU-R during initialization (O-TPS).</p>

13.3 Timing of changes in subcarrier configuration

In both the upstream and the downstream directions, the reconfiguration of the PMD functions shall take effect starting with the tenth symbol that follows transport of the Syncflag for OLR type 1. As defined in clause 10.2, the sync symbol is transmitted after every 256 data symbols. The reconfiguration of the PMD function shall take effect starting with the symbol at symbol count 9 in the next DMT superframe, where the first symbol in each DMT superframe is the symbol at symbol count 0.

For OLR Type 3, when performed in the latency path p , the change in L_p values and b_i, g_i values shall take effect starting from the 66th symbol that follows the Syncflag, i.e., the symbol with symbol count 65 in the DMT superframe following the Syncflag, where the first symbol in the DMT superframe is the symbol at symbol count 0.

The change of framing parameters T_p, G_p and B_{p0} shall take effect on the first OH frame of the first OH superframe that follows the 66th DMT symbol after the Syncflag.

The change in D_p shall take effect on the first byte of an interleaved RS codeword (byte k as defined in clause 9.4.1). This codeword shall be determined as follows:

- For a decrease in interleaver depth, this shall be the first RS codeword that starts at or after the beginning of the 66th DMT symbol.
- For an increase in interleaver depth, this shall be the last RS codeword that starts at or before the beginning of the 66th DMT symbol.

The location of the RS codeword relative to the 66th DMT symbol is illustrated in Figure 13-1.

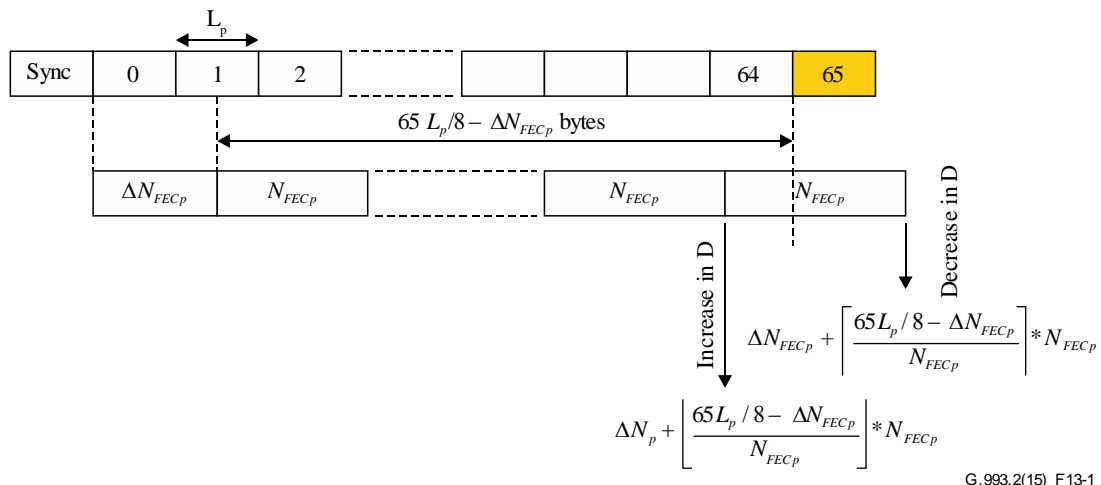

G.993.2(15)_F13-1

Figure 13-1 – Finding the byte where the change in D_p is activated

Figure 13-1 shows the DMT symbol counter and the byte counter at which the interleaver depth change is activated, relative to the Syncflag. For an increase in depth, the change in D_p will always happen at the same time or before the change in L_p , but as close to it as possible (i.e., the change in D_p happens during the DMT symbol with count 64 or sooner). Likewise, for a decrease in depth, the change in D_p will always happen at the same time or after the change in L_p , but as close to it as possible (i.e., the change in D_p happens during the DMT symbol with count 65 or later).

For OLR Type 4 (SOS), the change in L_p values and b_i values shall take effect starting from the 66th symbol that follows the Syncflag, i.e., the symbol with symbol count 65 in the DMT superframe following the Syncflag, where the first symbol in the DMT superframe is the symbol at symbol count 0.

For all the used tones in an SOS tone group k , the same b_i reduction $\Delta b(k)$ is applied, except for tones that belong to the ROC. Specifically, the new $b_i' = b_i - \Delta b(k)$. If the new b_i' value is < 2 , it shall be set to 0. Thus, no new 1-bit loading will be created in SOS. If the resulting b_i' contains an odd number of 1-bit constellation points and trellis is enabled, the last (according to reordered tone ordering table) 1-bit constellation should be set to $b_i' = 0$.

When the SOS request is executed in multiple steps, the tones shall be updated in groups of size G_{SOS} , where G_{SOS} is the minimum of the values indicated by VTU-R and VTU-O in R-MSG2 and O-MSG1 respectively. The tones shall be updated in the order determined by the reordered tone ordering table. To insure that the bit-loading after each step contains an even number of 1-bit constellation, the tone with the unpaired 1-bit constellation shall be removed from this step and included in the next step.

The change in bit loading for the first group of tones shall be done at the 66th symbol that follows the Syncflag. The change for subsequent groups shall be done T_{SOS} symbols after the execution of the previous group (on the symbol count $65 + s \times T_{SOS}$, $s = 1, 2, \dots, N-1$, sync symbols are not counted) until all tones have been changed. The last group may have less than G_{SOS} tones. The value of T_{SOS} depends on the selected value of G_{SOS} and shall be as presented in Table 13-4.

NOTE – The number of steps N depends on the total number of tones, W , subject to bit loading change during the SOS. It can be computed as $N = \text{ceiling}(W/G_{SOS})$. Assuming the maximum number of tones in the transmit direction for the band plans defined in Annexes A, B and C, N does not exceed 12 for $G_{SOS} = 256$, 6 for $G_{SOS} = 512$, and 3 for $G_{SOS} = 1\ 024$.

Table 13-4 – G_{SOS} and associated values of T_{SOS}

G_{SOS}	T_{SOS} (4.3125 kHz)	T_{SOS} (8.625 kHz)
256	48	96
512	72	144
1 024	96	192
All tones	N/A	N/A

In the case of multi-step, the value of D (interleaver depth) shall be changed with the last group of tones. The change shall happen at the same symbol or at the first opportunity after the change of bit loading for the last group of tones (during the DMT symbol with count $65 + (N-1) \times T_{SOS}$ or later).

When the SOS request is executed in a single step, the value of D shall be changed as described in this clause for OLR type 3.

After it has received an SOS request, the VTU shall respond within 200 ms with either a Syncflag or a reject type 4 invalid parameters response (see Table 11-8). When the execution is done in multiple steps, the total time between reception of the message and full execution of the command shall not exceed 300 ms. In addition, the VTU shall respond within 146.5 ms after it has received an SOS request with either a Syncflag or a reject type 4 invalid parameters response. The response shall be

sent at the first opportunity after the SOS request is received provided there is enough time to execute the first step of a multi-step activation.

During the transition of OLR type 4 in single or multiple steps, bit errors may occur. Once the transition is completed, the VTU shall operate at a BER not exceeding the nominal BER, unless the line conditions do not allow it.

13.4 Receiver initiated procedure

If a VTU receiver initiates a reconfiguration, it computes the necessary change in the related parameters (e.g., bits and gains table) and requests this change in the transmit PMD function of the VTU at the other end of the line. After it receives a positive acknowledgment, as specified in clause 11.2.3.3, the VTU shall change the relevant control parameters of its own receive PMD function and the PMS-TC function at the time specified in clause 13.3.

A VTU receiver may initiate an OLR type 1 (Bit Swapping). A bit swap request shall change only the bits and gains table. It shall not modify the L value. Bit swapping reconfigurations involve changes of only the PMD sublayer configuration parameters. They do not change the TPS-TC and PMS-TC sublayer configuration parameters.

The transmit PMD function shall support bit swaps requested by the receive PMD function.

If OLR type 3 (SRA) is supported (in downstream or upstream direction, respectively), and enabled (through RA-MODE=3), a VTU receiver shall initiate an SRA when the conditions in clause 13.4.1 or clause 13.4.2 are satisfied.

If OLR type 3 (SRA) is supported (in downstream or upstream direction, respectively), and enabled (through RA-MODE=4), a VTU receiver shall initiate an SRA when the conditions in clause 13.4.1, clause 13.4.2 or clause 13.4.3 are satisfied. A VTU receiver may initiate a SRA when the conditions in clause 13.4.4 are satisfied.

If OLR type 4 (SOS) is supported (in downstream or upstream direction, respectively), and enabled (through RA-MODE=4), a VTU receiver shall initiate an SOS when the conditions in clause 13.4.3 are satisfied.

A VTU receiver shall only send OLR request commands that meet all of following constraints:

- Impulse noise protection \geq Minimum impulse noise protection for all bearer channels;
- Delay \leq Maximum delay for all bearer channels;

A VTU receiver shall only send SOS requests that meet the following constraints:

- Net data rate (NDR_n) \geq Minimum SOS net data rate (MIN-SOS-BR_n) for all bearer channels;

NOTE – An SOS request could result in a message overhead data rate that is temporarily below the configured minimum message overhead data rate. This will be corrected by a subsequent SRA procedure. See clause 13.4.3.3.

A VTU receiver shall only send SRA requests that meet the following constraints:

- Maximum net data rate \geq Net data rate \geq Minimum net data rate for all bearer channels, unless the actual net data rate is below the minimum net data rate as a result of an SOS procedure. In that case, SRA is only allowed to ask for rate increases, but the requested Net data rate is allowed to be below Minimum net data rate.
- Message overhead data rate \geq Minimum message overhead data rate;
- $DV_n \leq DV_{max_n}$ for all bearer channels.

13.4.1 Receiver Initiated SRA downshift procedure

If the noise margin is below the downshift noise margin ($RA-DSNRM$) and stays below that for more than the time specified by the minimum downshift rate adaptation interval ($RA-DTIME$), the VTU

shall attempt to decrease the net data rate, such that the noise margin is increased to a level higher than or equal to the Downshift Noise Margin + 1 dB (see Figure 13-2).

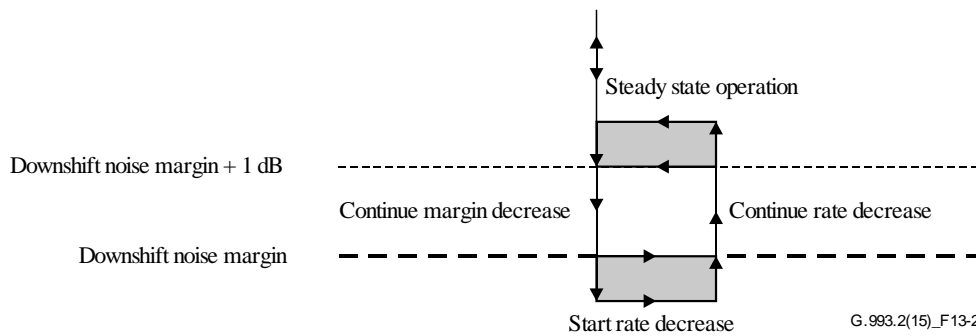

Figure 13-2 – SRA downshift procedure

If a $DVmax_p$ parameter specifies a bound on delay variation, it is possible that the rate decrease allowed by this maximum delay variation in a single SRA request is not sufficient to re-establish the margin to downshift noise margin + 1 dB. In this case, a number of consecutive SRA requests shall be executed until the margin is higher than or equal to the downshift noise margin + 1 dB.

13.4.2 Receiver initiated SRA upshift procedure

If the noise margin is above the upshift noise margin ($RA-USNRM$) and stays above that for more than the time specified by the minimum upshift rate adaptation interval ($RA-UTIME$), the VTU shall attempt to increase the net data rate, such that the noise margin is decreased to a level lower than or equal to the upshift noise margin – 1 dB (see Figure 13-3).

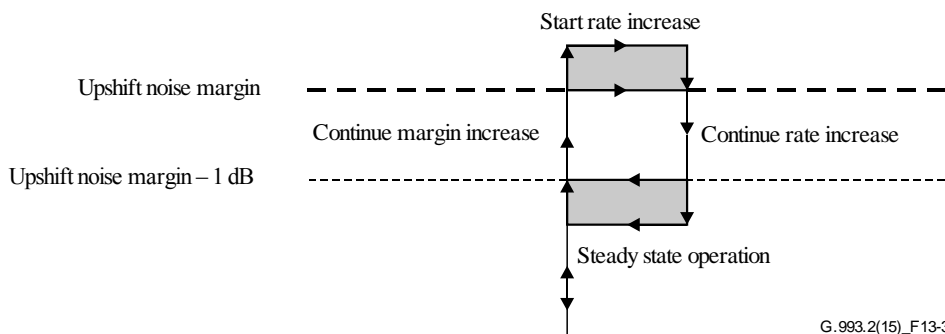

Figure 13-3 – SRA upshift procedure

If a $DVmax_p$ parameter specifies a bound on delay variation, it is possible that the rate increase allowed by this maximum delay variation in a single SRA request, is not sufficient to re-establish the margin to upshift noise margin – 1 dB. In this case, a number of consecutive SRA requests shall be executed until the margin is lower than or equal to the upshift noise margin – 1 dB.

13.4.3 Receiver initiated SOS

13.4.3.1 SOS triggering parameters

For each direction, three SOS triggering parameters are defined to support the standard SOS triggering criteria defined in clause 13.4.3.2.

13.4.3.1.1 SOS time Window (SOS-TIME)

The special value zero indicates that the standard SOS triggering criteria are disabled, i.e., vendor discretionary values may be used instead of the values configured in the MIB for the following parameters: SOS-NTONES, SOS-CRC, and SOS-TIME.

A non-zero value indicates that the standard SOS triggering criteria are enabled. In this case, SOS-TIME is the duration of the time window used in the standard SOS triggering criteria (see clause 13.4.3.2). This time window shall be applied to sequential time steps (i.e., not a sliding window).

The SOS-TIME defined for the downstream and upstream are denoted as SOS-TIME-ds and SOS-TIME-us, respectively.

13.4.3.1.2 Minimum Percentage of Degraded Tones (SOS-NTONES)

SOS-NTONES is the minimum percentage of loaded tones (i.e., tones with $b_i > 0$) that must be persistently degraded throughout the time window SOS-TIME, in order to arm the first subcondition of the standard SOS triggering criteria (see clause 13.4.3.2).

A degraded tone is a tone that has been identified as needing a reduction in bit loading because, with its current bit loading, it contributes substantially to the increase of the BER above the nominal value. The degraded tones are not necessarily contiguous.

The SOS-NTONES defined for the downstream and upstream are denoted as SOS-NTONES-ds and SOS-NTONES-us, respectively.

13.4.3.1.3 Minimum Number of normalized CRC anomalies (SOS-CRC)

SOS-CRC is the minimum number of normalized CRC anomalies received in SOS-TIME seconds, in order to arm the second subcondition of the standard SOS triggering criteria (see clause 13.4.3.2).

The "count of normalized CRC anomalies" shall be incremented by the $\Delta\text{CRCsecp}$ (the one-second normalized CRC anomaly counter increment, as defined in Table 9-8 of this Recommendation) for each occurrence of a crc-p anomaly.

The SOS-CRC defined for the downstream and upstream are denoted as SOS-CRC-ds and SOS-CRC-us, respectively.

13.4.3.2 Standard SOS triggering criteria

If the following conditions hold:

- the standard SOS triggering criteria are enabled (through $\text{SOS-TIME} \neq 0$);
- the percentage of tones in the MEDLEY SET that are persistently degraded throughout the time window SOS-TIME exceeds SOS-NTONES; and
- the count of normalized CRC anomalies throughout the same time window SOS-TIME exceeds SOS-CRC;

then the VTU:

- shall send either an SOS request or an SRA request if the number of degraded tones is ≤ 128 and the message length of the SRA request has a duration less than 100 ms, or
- shall send an SOS request if the number of degraded tones > 128 or if the message length of the SRA request has a duration more than 100 ms.

These SRA requests are not required to respect either RA-TIME or RA-SNRM.

The time between the moment that the SOS trigger conditions have become valid, and the SOS request or SRA request sent by the VTU appears at the U-interface, shall be less than 128 ms if there is no other outstanding OLR request.

If the standard SOS triggering criteria are disabled (through $SOS-TIME = 0$), the VTU may send SOS requests or SRA requests based on vendor-discretionary SOS triggering criteria. After each successful SOS, or SRA based on SOS triggering criteria, the count of normalized CRC anomalies shall be reset and a new time window shall be started.

13.4.3.3 Generic requirements for receiver initiated SOS

The VTU shall not send an SOS request if SOS is disabled ($RA-MODE \neq 4$).

In the case the SOS results in a PER_p value outside the bounds given in Table 9-8, the VTU that initiated the SOS request shall send a subsequent SRA request within 1 second to bring the PER_p back within these bounds.

In the case the SOS results in an msg_p value outside the bounds given in Table 9-8, the VTU that initiated the SOS request shall send a subsequent SRA request within 1 second to bring the msg_p back within these bounds.

13.4.4 Receiver Initiated SRA following an SOS procedure

A VTU shall send one or more SRA requests following an SOS procedure to remediate the situation in which the current rate is less than Minimum Net Data Rate, or the actual noise margin is greater than the target noise margin. As long as the current bit rate is less than Minimum Net Data Rate, or the actual noise margin is greater than the target noise margin, these SRA requests are not required to respect either $RA-UTIME$ or $RA-USNRM$.

NOTE – Although these SRA requests can be issued at the discretion of the VTU, the Note in clause 13.1 defines a goal for the overall duration of the SOS procedure.

14 Electrical requirements

14.1 Termination impedance model

The termination impedance model is for further study.

NOTE – The reference impedance model is intended to be used for splitter testing only, and is not intended to imply requirements on the values of the input impedance to be implemented in the transceiver.

14.2 Service splitters

For further study.

14.3 Input capacitance

Input capacitance requirements are shown in Table 14-1.

Table 14-1 – Input capacitance requirements

Underlying service			Min capacitance (nF)	Max capacitance (nF)
POTS	Integrated HPF	With US0	20	34
		Without US0	For further study	34
	External HPF	With US0	30	78
		Without US0	For further study	78
ISDN	Integrated HPF	With US0	6	11
		Without US0	For further study	11
	External HPF	With US0	10.8	59
		Without US0	For further study	59
No underlying service	N/A	N/A	No requirement	No requirement
NOTE – Capacitance shall be measured at a single frequency ≤ 4 kHz for over POTS and ≤ 30 kHz for over ISDN.				

Annex A

Region A (North America)

(This annex forms an integral part of this Recommendation.)

A.1 Band plan

The band plan for North America is shown in Figure A.1. The US0 band, if present, has a lower frequency, f_{0L} , which can vary from 4 kHz (without POTS) to 25 kHz (with POTS), and an upper frequency, f_{0H} , which can vary from 138 to 276 kHz.

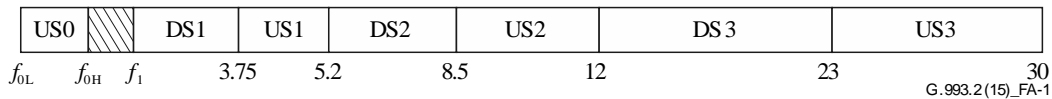

Figure A.1 – Band plan for North America

A.2 Limit PSD masks

The breakpoint frequencies and PSD values in Tables A.1 through A.8 are exact. The indicated slopes shown in corresponding Figures A.2 through A.6 are approximate.

NOTE 1 – The out-of-band specification above 1.1 MHz is governed by the stopband specification in Table 7-2.

NOTE 2 – It is expected that methods to verify compliance to the Limit PSD mask will be defined by the regional bodies.

A.2.1 VTU-R Limit PSD masks

The Limit PSD mask between the breakpoints is determined using the following interpolation rules:

- For frequencies less than (3 750 – 175) kHz, the breakpoints in Tables A.1 through A.8 shall be connected linearly on a plot with the abscissa $\log_{10}(f)$ and the ordinate the Limit PSD mask in dBm/Hz.
- For frequencies above (3 750 – 175) kHz, the breakpoints in Tables A.1 through A.8 shall be connected linearly on a plot with the abscissa f and the ordinate the Limit PSD mask in dBm/Hz.

A.2.1.1 VTU-R operation over POTS

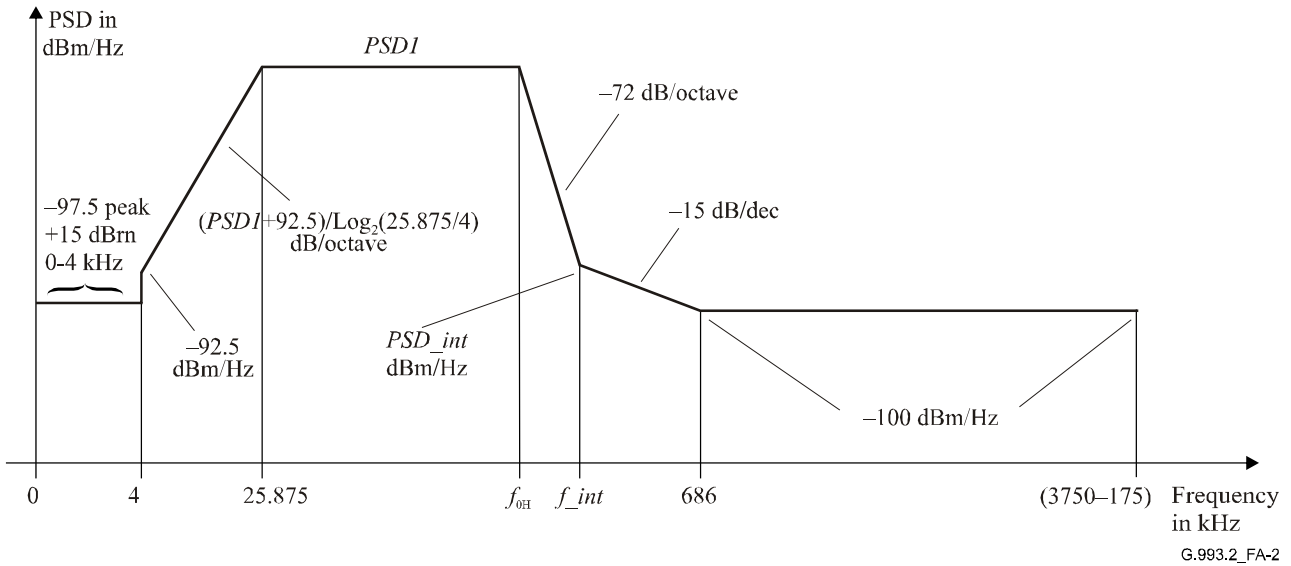

Figure A.2 – VTU-R US0 Limit PSD mask for operation over POTS

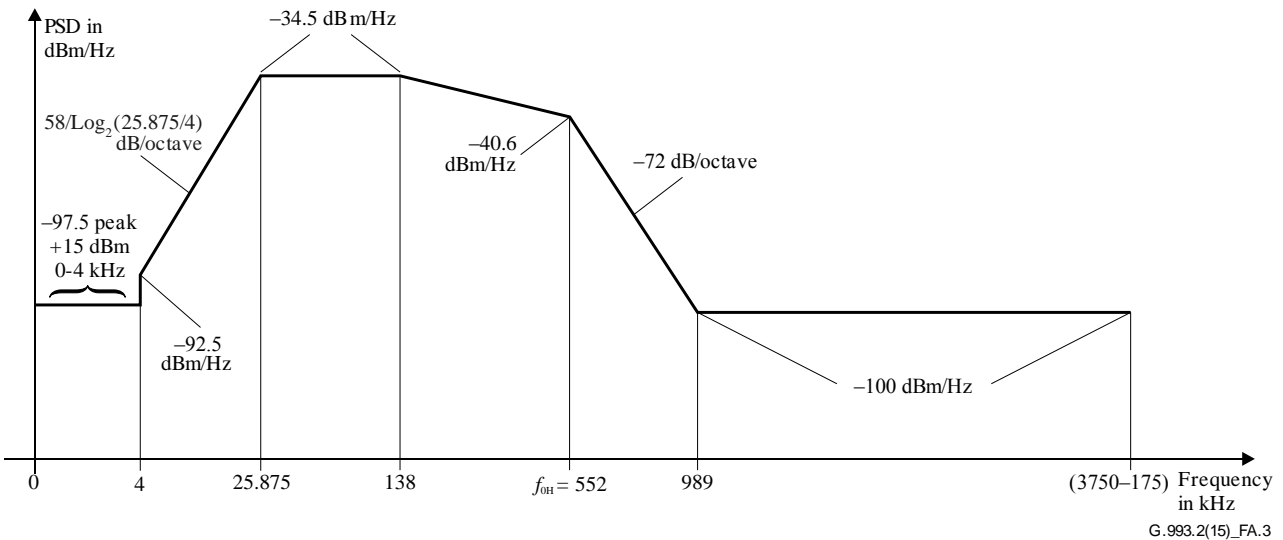

Figure A.3 – VTU-R EU-128 Limit PSD mask for operation over POTS

Table A.1 – VTU-R Limit PSD mask for operation over POTS as a function of profile

Frequency (kHz)	Limit PSD mask level (dBm/Hz) for profiles 8a, 8b, 8c, 8d	Limit PSD mask level (dBm/Hz) for profiles 12a, 12b, 17a	Limit PSD mask level (dBm/Hz) for profile 30a
0	-97.5	-97.5	-97.5
4	-97.5	-97.5	-97.5
4	-92.5	-92.5	-92.5
25.875	$PSD1$ (see Table A.2)	$PSD1$	$PSD1$ (see Table A.2)
f_{0H}	$PSD1$ (see Table A.2)	$PSD1$	$PSD1$ (see Table A.2)
f_{int}	PSD_{int} (see Table A.2)	PSD_{int}	PSD_{int} (see Table A.2)

Table A.1 – VTU-R Limit PSD mask for operation over POTS as a function of profile

Frequency (kHz)	Limit PSD mask level (dBm/Hz) for profiles 8a, 8b, 8c, 8d	Limit PSD mask level (dBm/Hz) for profiles 12a, 12b, 17a	Limit PSD mask level (dBm/Hz) for profile 30a
686	-100	-100	-100
1 104	-100	-100	-100
3 750 – 175	-100	-100	-100
3 750	-80	-80	-80
3 750	-53 + 3.5	-53 + 3.5	-53 + 3.5
5 200	-53 + 3.5	-53 + 3.5	-53 + 3.5
5 200	-80	-80	-80
5 200 + 175	-100	-100	-100
8 500 – 175	-100	-100	-100
8 500	-100	-80	-80
8 500	-100	-54 + 3.5	-54 + 3.5
12 000	-100	-54 + 3.5	-54 + 3.5
12 000	-100	-80	-80
12 000 + 175	-100	-100	-100
23 000 – 175	-100	-100	-100
23 000	-100	-100	-80
23 000	-100	-100	-60 + 3.5
30 000	-100	-100	-60 + 3.5
30 000	-110	-110	-80
30 175	-110	-110	-110
≥ 30 175	-110	-110	-110

Table A.2 – PSD1, PSD_{int} and the frequencies f_{0H} and f_{int}

Upstream mask-number	Designator	PSD1 (dBm/Hz)	Frequency f_{0H} (kHz)	Intercept frequency f_{int} (kHz)	Intercept PSD level PSD_{int} (dBm/Hz)
1	EU-32	-34.5	138.00	242.92	-93.2
2	EU-36	-35.0	155.25	274.00	-94.0
3	EU-40	-35.5	172.50	305.16	-94.7
4	EU-44	-35.9	189.75	336.40	-95.4
5	EU-48	-36.3	207.00	367.69	-95.9
6	EU-52	-36.6	224.25	399.04	-96.5
7	EU-56	-36.9	241.50	430.45	-97.0
8	EU-60	-37.2	258.75	461.90	-97.4
9	EU-64	-37.5	276.00	493.41	-97.9

Table A.2 – PSD1, PSD_{int} and the frequencies f_{0H} and f_{int}

Upstream mask-number	Designator	PSD1 (dBm/Hz)	Frequency f_{0H} (kHz)	Intercept frequency f_{int} (kHz)	Intercept PSD level PSD_{int} (dBm/Hz)
NOTE – EU-32 through EU-64 shall not be used in conjunction with D-128.					

Table A.3 – VTU-R EU-128 Limit PSD mask for operation over POTS as a function of profile

Frequency (kHz)	Limit PSD mask level (dBm/Hz) for profiles 8a, 8b, 8c, 8d	Limit PSD mask level (dBm/Hz) for profiles 12a, 12b, 17a	Limit PSD mask level (dBm/Hz) for profile 30a
0	-97.5	-97.5	-97.5
4	-97.5	-97.5	-97.5
4	-92.5	-92.5	-92.5
25.875	-34.5	-34.5	-34.5
138	-34.5	-34.5	-34.5
$f_{0H} = 552$	$-34.5 - 10 \times \log_{10}(f_{0H} - 3) / (138 - 3)$	$-34.5 - 10 \times \log_{10}(f_{0H} - 3) / (138 - 3)$	$-34.5 - 10 \times \log_{10}(f_{0H} - 3) / (138 - 3)$
989	-100	-100	-100
1 104	-100	-100	-100
3 750 – 175	-100	-100	-100
3 750	-80	-80	-80
3 750	-53 + 3.5	-53 + 3.5	-53 + 3.5
5 200	-53 + 3.5	-53 + 3.5	-53 + 3.5
5 200	-80	-80	-80
5 200 + 175	-100	-100	-100
8 500 – 175	-100	-100	-100
8 500	-100	-80	-80
8 500	-100	-54 + 3.5	-54 + 3.5
12 000	-100	-54 + 3.5	-54 + 3.5
12 000	-100	-80	-80
12 000 + 175	-100	-100	-100
23 000 – 175	-100	-100	-100
23 000	-100	-100	-80
23 000	-100	-100	-60 + 3.5
30 000	-100	-100	-60 + 3.5
30 000	-110	-110	-80
30 175	-110	-110	-110
$\geq 30 175$	-110	-110	-110

A.2.1.2 VTU-R All-digital mode operation

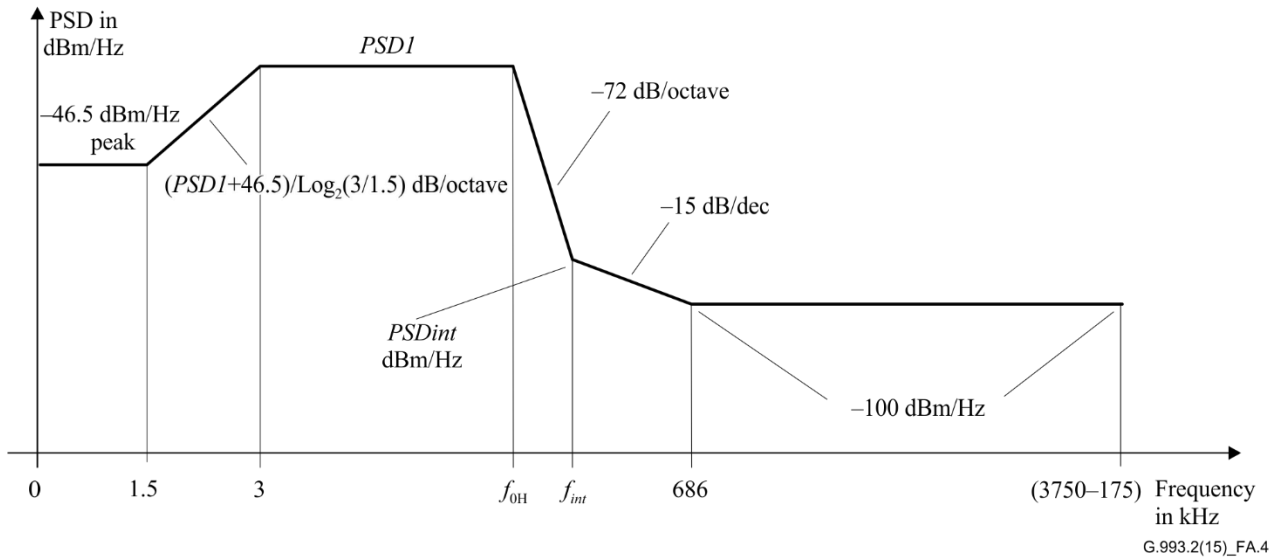

Figure A.4 – VTU-R US0 Limit PSD mask for all-digital mode operation

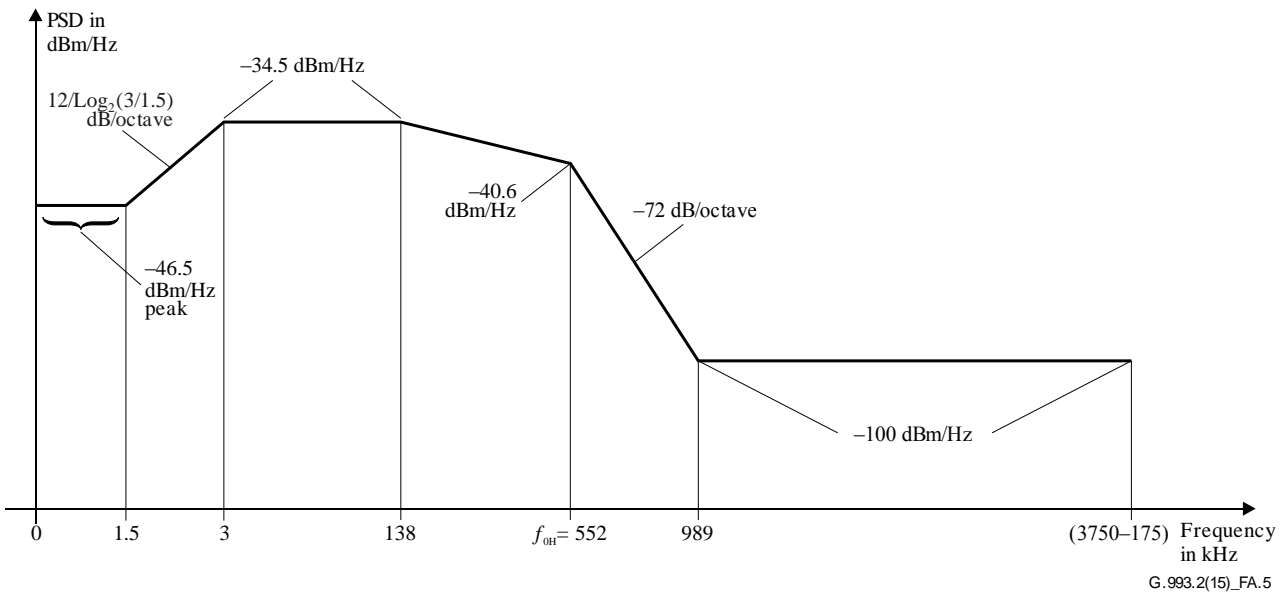

Figure A.5 – VTU-R ADLU-128 limit PSD mask for all-digital mode operation

Table A.4 – VTU-R limit PSD mask for all-digital mode operation as a function of profile

Frequency (kHz)	Limit PSD mask level (dBm/Hz) for profiles 8a, 8b, 8c, 8d	Limit PSD mask level (dBm/Hz) for profiles 12a, 12b, 17a	Limit PSD mask level (dBm/Hz) for profile 30a
0	-46.5	-46.5	-46.5
1.5	-46.5	-46.5	-46.5
3	<i>PSDI</i> (see Table A.5)	<i>PSDI</i>	<i>PSDI</i> (see Table A.5)
f_{0H}	<i>PSDI</i> (see Table A.5)	<i>PSDI</i>	<i>PSDI</i> (see Table A.5)

Table A.4 – VTU-R limit PSD mask for all-digital mode operation as a function of profile

Frequency (kHz)	Limit PSD mask level (dBm/Hz) for profiles 8a, 8b, 8c, 8d	Limit PSD mask level (dBm/Hz) for profiles 12a, 12b, 17a	Limit PSD mask level (dBm/Hz) for profile 30a
f_{int}	PSD_{int} (see Table A.5)	PSD_{int}	PSD_{int} (see Table A.5)
686	-100	-100	-100
1 104	-100	-100	-100
3 750 – 175	-100	-100	-100
3 750	-80	-80	-80
3 750	-53 + 3.5	-53 + 3.5	-53 + 3.5
5 200	-53 + 3.5	-53 + 3.5	-53 + 3.5
5 200	-80	-80	-80
5 200 + 175	-100	-100	-100
8 500 – 175	-100	-100	-100
8 500	-100	-80	-80
8 500	-100	-54 + 3.5	-54 + 3.5
12 000	-100	-54 + 3.5	-54 + 3.5
12 000	-100	-80	-80
12 000 + 175	-100	-100	-100
23 000 – 175	-100	-100	-100
23 000	-100	-100	-80
23 000	-100	-100	-60 + 3.5
30 000	-100	-100	-60 + 3.5
30 000	-110	-110	-80
30 175	-110	-110	-110
$\geq 30 175$	-110	-110	-110

Table A.5 – $PSD1$, PSD_{int} and the frequencies f_{0H} and f_{int}

Upstream mask-number	Designator	$PSD1$ (dBm/Hz)	Frequency f_{0H} (kHz)	Intercept frequency f_{int} (kHz)	Intercept PSD level PSD_{int} (dBm/Hz)
1	ADLU-32	-34.5	138.00	242.92	-93.2
2	ADLU-36	-35.0	155.25	274.00	-94.0
3	ADLU-40	-35.5	172.50	305.16	-94.7
4	ADLU-44	-35.9	189.75	336.40	-95.4
5	ADLU-48	-36.3	207.00	367.69	-95.9
6	ADLU-52	-36.6	224.25	399.04	-96.5
7	ADLU-56	-36.9	241.50	430.45	-97.0
8	ADLU-60	-37.2	258.75	461.90	-97.4

Table A.5 – PSD1, PSD_{int} and the frequencies f_{0H} and f_{int}

Upstream mask-number	Designator	PSD1 (dBm/Hz)	Frequency f_{0H} (kHz)	Intercept frequency f_{int} (kHz)	Intercept PSD level PSD _{int} (dBm/Hz)
9	ADLU-64	-37.5	276.00	493.41	-97.9
NOTE – ADLU-32 through ADLU-64 shall not be used in conjunction with D-128.					

Table A.6 – VTU-R ADLU-128 Limit PSD mask for all-digital mode operation as a function of profile

Frequency (kHz)	Limit PSD mask level (dBm/Hz) for profiles 8a, 8b, 8c, 8d	Limit PSD mask level (dBm/Hz) for profiles 12a, 12b, 17a	Limit PSD mask level (dBm/Hz) for profile 30a
0	-46.5	-46.5	-46.5
1.5	-46.5	-46.5	-46.5
3	-34.5	-34.5	-34.5
138	-34.5	-34.5	-34.5
$f_{0H} = 552$	$-34.5 - 10 \times \log_{10}(f_{0H} - 3) / (138 - 3)$	$-34.5 - 10 \times \log_{10}(f_{0H} - 3) / (138 - 3)$	$-34.5 - 10 \times \log_{10}(f_{0H} - 3) / (138 - 3)$
989	-100	-100	-100
1 104	-100	-100	-100
3 750 – 175	-100	-100	-100
3 750	-80	-80	-80
3 750	-53 + 3.5	-53 + 3.5	-53 + 3.5
5 200	-53 + 3.5	-53 + 3.5	-53 + 3.5
5 200	-80	-80	-80
5 200 + 175	-100	-100	-100
8 500 – 175	-100	-100	-100
8 500	-100	-80	-80
8 500	-100	-54 + 3.5	-54 + 3.5
12 000	-100	-54 + 3.5	-54 + 3.5
12 000	-100	-80	-80
12 000 + 175	-100	-100	-100
23 000 – 175	-100	-100	-100
23 000	-100	-100	-80
23 000	-100	-100	-60 + 3.5
30 000	-100	-100	-60 + 3.5
30 000	-110	-110	-80
30 175	-110	-110	-110
$\geq 30 175$	-110	-110	-110

NOTE – The actual transmit PSD shape is further constrained by the total power limit of 14.5 dBm as well as additional spectral compatibility rules imposed by regional authorities.

A.2.2 VTU-O Limit PSD masks

The Limit PSD mask between the breakpoints is determined using the following interpolation rules:

- For frequencies less than f_1 , the breakpoints in Tables A.1 through A.8 shall be connected linearly on a plot with the abscissa $\log_{10}(f)$ and the ordinate the Limit PSD mask in dBm/Hz.
- For frequencies above f_1 , the breakpoints in Tables A.1 through A.8 shall be connected linearly a plot with the abscissa f and the ordinate the Limit PSD mask in dBm/Hz.

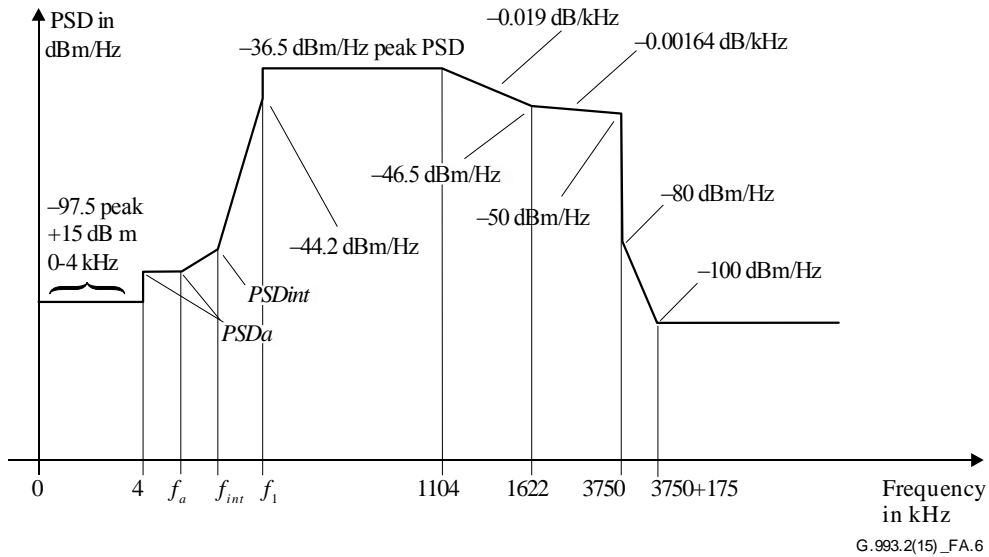

Figure A.6 – VTU-O DS1 limit PSD mask

Table A.7 – VTU-O Limit PSD mask as a function of profile

Frequency (kHz)	Limit PSD mask level (dBm/Hz) for profiles 8a, 8b, 8c, 8d, 12a and 12b	Limit PSD mask level (dBm/Hz) for profile 17a	Limit PSD mask level (dBm/Hz) for profile 30a
0	-97.5	-97.5	-97.5
4	-97.5	-97.5	-97.5
4	$PSDa$ (see Table A.8)	$PSDa$ (see Table A.8)	$PSDa$ (see Table A.8)
f_a	$PSDa$ (see Table A.8)	$PSDa$ (see Table A.8)	$PSDa$ (see Table A.8)
f_{int}	PSD_{int} (see Table A.8)	PSD_{int} (see Table A.8)	PSD_{int} (see Table A.8)
f_1	-44.2	-44.2	-44.2
f_1	-36.5	-36.5	-36.5
1 104	-36.5	-36.5	-36.5
1 622	$-50 + 3.5$	$-50 + 3.5$	$-50 + 3.5$
3 750	$-53.5 + 3.5$	$-53.5 + 3.5$	$-53.5 + 3.5$
3 750	-80	-80	-80
3 750 + 175	-100	-100	-100
5 200 - 175	-100	-100	-100
5 200	-80	-80	-80
5 200	$-55 + 3.5$	$-55 + 3.5$	$-55 + 3.5$

Table A.7 – VTU-O Limit PSD mask as a function of profile

Frequency (kHz)	Limit PSD mask level (dBm/Hz) for profiles 8a, 8b, 8c, 8d, 12a and 12b	Limit PSD mask level (dBm/Hz) for profile 17a	Limit PSD mask level (dBm/Hz) for profile 30a
8 500	-55 + 3.5	-55 + 3.5	-55 + 3.5
8 500	-80	-80	-80
8 500 + 175	-100	-100	-100
12 000 – 175	-100	-100	-100
12 000	-100	-80	-80
12 000	-100	-60 + 3.5	-60 + 3.5
17 664	-100	-60 + 3.5	-60 + 3.5
21 000	-100	-80	-60 + 3.5
21 450	-100	-100	-60 + 3.5
23 000	-100	-100	-60 + 3.5
23 000	-100	-100	-80
23 000 + 175	-100	-100	-100
30 000	-100	-100	-100
≥ 30 000	-110	-110	-110

Table A.8 – PSD_{int} and $PSDa$ and the frequencies f_1 , f_{int} , and f_a

Designator	f_1 (kHz)	f_{int} (kHz)	PSD_{int} (dBm/Hz)	f_a (kHz)	$PSDa$ (dBm/Hz)
D-32	138.00	80	-72.5	4	-92.5
D-48	207.00	155	-62	53	-90
D-64	276.00	227.1	-62	101.2	-90
D-128 (Note)	552.00	440	-68	240	-90

NOTE – D-128 shall only be used in conjunction with EU-128 or ADLU-128.

A.3 UPBO reference PSDs

ATIS Committee NIPP has published a technical report [b-ATIS-0600023] that provides guidance on the configuration of the UPBO parameters 'a' and 'b' for the North American environment.

Annex B

Region B (Europe)

(This annex forms an integral part of this Recommendation.)

B.1 Band plans

This annex defines the various band plans required for European deployment of VDSL2 systems operating at a maximum frequency of 12, 17, 30 or 35 MHz. These are based on [ITU-T G.993.1] band plans A and B (also referred to as plan 998 and plan 997, respectively). The various band plans are defined in Table B.1 below and can be summarized as follows:

Plan 997	The original plan 997 ($f_{max} = 12$ MHz).
Plan 997E17	Plan 997 directly extended to $f_{max} = 17.664$ MHz.
Plan 997E30	Plan 997 directly extended to $f_{max} = 30$ MHz. NOTE – Plan 997E17 and plan 997 are truncated versions of plan 997E30.
Plan 998	The original plan 998 ($f_{max} = 12$ MHz).
Plan 998E17	Plan 998 directly extended to $f_{max} = 17.664$ MHz.
Plan 998E30	Plan 998 directly extended to $f_{max} = 30$ MHz. NOTE – Plan 998E17 and plan 998 are truncated versions of plan 998E30.
Plan 998E35	Plan 998 directly extended to $f_{max} = 35.328$ MHz (frequencies above 14 MHz are for downstream transmission only). NOTE – Plan 998E17 and plan 998 are truncated versions of plan 998E30 and plan 998E35.
Plan 998ADE17	Plan 998 extended to $f_{max} = 17.664$ MHz (downstream transmission only above 12 MHz)
Plan 998ADE30	Plan 998 extended to $f_{max} = 30$ MHz.
Plan 998ADE35	Plan 998 extended to $f_{max} = 35.328$ MHz (frequencies above 12 MHz are for downstream transmission only). NOTE – Plan 998ADE17 and plan 998 are truncated versions of plan 998ADE30 and plan 998ADE35.

Different variants are defined for band plans 997, 998, 998E17, 998E30, 998E35, 998ADE17, 998ADE30 and 998ADE35 to accommodate different underlying services (POTS and ISDN), and different US0 bandwidths.

Table B.1 – Band-edge frequencies for European VDSL2 band plans

Band plan	Band-edge frequencies (as defined in the generic band plan in clause 7.1.2)										
	f_{0L} kHz	f_{0H} kHz	f_1 kHz	f_2 kHz	f_3 kHz	f_4 kHz	f_5 kHz	f_6 kHz	f_7 kHz	f_8 kHz	f_9 kHz
	US0		DS1	US1	DS2	US2	DS3	US3	DS4	US4	
997	25	138	138	3 000	5 100	7 050	12 000	N/A	N/A	N/A	N/A
	25	276	276								
997E17	25	138	138	3 000	5 100	7 050	12 000	14 000	17 664	N/A	N/A
997E30	N/A	N/A	138	3 000	5 100	7 050	12 000	14 000	19 500	27 000	30 000
	US0		DS1	US1	DS2	US2	US3	DS3	US4	DS4	
998	25	138	138	3 750	5 200	8 500	12 000	N/A	N/A	N/A	N/A
	25	276	276								
	120	276	276								
	N/A	N/A	138								
998E17	N/A	N/A	138	3 750	5 200	8 500	12 000	14 000	17 664	N/A	N/A
	N/A	N/A	276								
	25	138	138								
998E30	N/A	N/A	138	3 750	5 200	8 500	12 000	14 000	21 450	24 890	30 000
	N/A	N/A	276								
998E35	25	138	138	3 750	5 200	8500	12 000	14 000	35 328	N/A	N/A
	US0		DS1	US1	DS2	US2	DS3	US3			
998ADE17	25	138	138	3 750	5 200	8 500	12 000	17 664	N/A		
	120	276	276								
	25	276	276								

Table B.1 – Band-edge frequencies for European VDSL2 band plans

Band plan	Band-edge frequencies (as defined in the generic band plan in clause 7.1.2)										
	f_{0L} kHz	f_{0H} kHz	f_1 kHz	f_2 kHz	f_3 kHz	f_4 kHz	f_5 kHz	f_6 kHz	f_7 kHz	f_8 kHz	f_9 kHz
	N/A	N/A	276								
998ADE30	N/A	N/A	138	3 750	5 200	8 500	12 000	24 890	30 000		
	N/A	N/A	276								
998ADE35	25	138	138	3 750	5 200	8 500	12 000	35 328	N/A		
	120	276	276								
	25	276	276								

NOTE 1 – N/A in the columns f_{0L} and f_{0H} designates a band plan variant that does not use US0.
NOTE 2 – The capability to support US0 together with profile 17a is required for European VDSL2.
NOTE 3 – The capability to support US0 together with profile 35b is required for European VDSL2.

The f_i in Table B.1 are defined as follows:

- f_{0L} and f_{0H} : define lower and upper frequency of US0;
- f_1 to f_5 are the boundary frequencies of the bands DS1, US1, DS2, US2 as defined for VDSL1 for 997 and 998;
- f_5 to f_9 are the boundary frequencies for the bands US3, DS3, US4 and DS4 (extended bands);
- The extension of an existing band is considered as a separate band (e.g., 998E17: US3 12 MHz-14 MHz).

B.2 Limit PSD mask options

The Limit PSD mask options defined in this annex are shown in Tables B.2, B.3 and B.4, for various band plans.

Table B.2 – European Limit PSD mask options for band plan 997 (and its extensions)

Short name	Limit PSD mask (Long name)	Frequency	
		US0 type A/M (Note)	Highest used upstream or downstream frequency (kHz)
B7-1	997-M1c-A-7	A	7 050
B7-3	997-M1x-M	M	12 000
B7-9	997E17-M2x-A	A	17 664
B7-10	997E30-M2x-NUS0	N/A	30 000
NOTE – The US0 types stand for:			
<ul style="list-style-type: none"> • US0 type A corresponds to Annex A of [ITU-T G.992.5]; • US0 type M corresponds to Annex M of [ITU-T G.992.3] or of [ITU-T G.992.5]; • US0 type N/A designates a band plan variant that does not use US0. 			

Table B.3 – European limit PSD mask options for band plan 998 (and its extensions)

Short name	Limit PSD mask (Long name)	Frequency	
		US0 type A/B/M (Note)	Highest used upstream or downstream frequency (kHz)
B8-4	998-M2x-A	A	12 000
B8-5	998-M2x-M	M	12 000
B8-6	998-M2x-B	B	12 000
B8-7	998-M2x-NUS0	N/A	12 000
B8-8	998E17-M2x-NUS0	N/A	17 664
B8-9	998E17-M2x-NUS0-M	N/A	17 664
B8-10	998ADE17-M2x-NUS0-M	N/A	17 664
B8-11	998ADE17-M2x-A	A	17 664
B8-12	998ADE17-M2x-B	B	17 664
B8-13	998E30-M2x-NUS0	N/A	30 000
B8-14	998E30-M2x-NUS0-M	N/A	30 000
B8-15	998ADE30-M2x-NUS0-M	N/A	30 000
B8-16	998ADE30-M2x-NUS0-A	N/A	30 000
B8-17	998ADE17-M2x-M	M	17 664
B8-18	998E17-M2x-A	A	17 664

Table B.3 – European limit PSD mask options for band plan 998 (and its extensions)

Short name	Limit PSD mask (Long name)	Frequency	
		US0 type A/B/M (Note)	Highest used upstream or downstream frequency (kHz)
B8-19	998E35-M2x-A	A	35 328
B8-20	998ADE35-M2x-A	A	35 328
B8-21	998ADE35-M2x-B	B	35 328
B8-22	998ADE35-M2x-M	M	35 328

NOTE – The US0 types stand for:

- US0 type A corresponds to Annex A of [ITU-T G.992.5];
- US0 type B corresponds to Annex B of [ITU-T G.992.5];
- US0 type M corresponds to Annex M of [ITU-T G.992.3] or of [ITU-T G.992.5];
- US0 type N/A designates a band plan variant that does not use US0;
- 998ADE_{xx}-M2x-NUS0-M designate the variants in which DS1 starts at 276 kHz instead of 138 kHz.

B.2.1 General requirements in the band below 4 kHz

The noise in the voice band measured with psophometric weighting according to [ITU-T O.41] clause 3.3 shall not exceed –68 dBm. The psophometer shall be used in bridging mode and shall be calibrated for 600 ohm termination.

B.2.2 VTU-R Limit PSD masks for band plan 997 (and its extensions)

The VTU-R limit PSD masks for band plan 997 (and its extensions) are shown in Table B.4.

Table B.4 – VTU-R limit PSD masks for band plan 997 (and its extensions)

Name	B7-1	B7-3	B7-9	B7-10
Long name	997-M1-c-A-7	997-M1-x-M	997E17-M2x-A	997E30-M2x-NUS0
kHz	dBm/Hz	dBm/Hz	dBm/Hz	dBm/Hz
0	-97.5	-97.5	-97.5	-100
4	-97.5	-97.5	-97.5	-100
4	-92.5	-92.5	-97.5	-100
25.875	-34.5	-37.5	-34.5	-100
50	-34.5	-37.5	-34.5	-100
80	-34.5	-37.5	-34.5	-100
120	-34.5	-37.5	-34.5	-100
138	-34.5	-37.5	-34.5	-100
225	Interp	-37.5	Interp	-100
243	-93.2	-37.5	-93.2	-100
276	Interp	-37.5	Interp	-100
493.41	Interp	-97.9	Interp	-100
686	-100	-100	-100	-100
2 825	-100	-100	-100	-100
3 000	-80	-80	-80	-80
3 000	-56.5	-56.5	-50.3	-50.3
3 575	-56.5	-56.5	Interp	Interp
3 750	-56.5	-56.5	Interp	Interp
5 100	-56.5	-56.5	-52.6	-52.6
5 100	-80	-80	-80	-80
5 275	-100	-100	-100	-100
6 875	-100	-100	-100	-100
7 050	-100	-80	-80	-80
7 050	-100	-56.5	-54	-54
8 325	-100	-56.5	Interp	Interp
9 950	-100	-56.5	Interp	Interp
10 125	-100	-56.5	-55.5	-55.5
10 125	-100	-56.5	-55.5	-55.5
11 825	-100	-56.5	-55.5	-55.5
12 000	-100	-56.5	-55.5	-55.5
12 000	-100	-80	-80	-80
12 175	-100	-100	-100	-100
13 825	-100	-100	-100	-100
14 000	-100	-100	-80	-80

Table B.4 – VTU-R limit PSD masks for band plan 997 (and its extensions)

Name	B7-1	B7-3	B7-9	B7-10
Long name	997-M1-c-A-7	997-M1-x-M	997E17-M2x-A	997E30-M2x-NUS0
kHz	dBm/Hz	dBm/Hz	dBm/Hz	dBm/Hz
14 000	-100	-100	-56.5	-56.5
14 175	-100	-100	Interp	Interp
17 664	-100	-100	-56.5	-56.5
19 500	-100	-100	-80	-56.5
19 500	-100	-100	-80	-80
19 675	-100	-100	-100	-100
21 275	-100	-100	-100	-100
21 450	-100	-100	-100	-100
21 450	-100	-100	-100	-100
24 890	-100	-100	-100	-100
24 890	-100	-100	-100	-100
25 065	-100	-100	-100	-100
26 825	-100	-100	-100	-100
27 000	-100	-100	-100	-80
27 000	-100	-100	-100	-56.5
30 000	-100	-100	-100	-56.5
30 000	-110	-110	-110	-80
30 175	-110	-110	-110	-110
> 30 175	-110	-110	-110	-110

NOTE – The PSD values between breakpoints including the values marked by "Interp" shall be obtained by interpolation between adjacent breakpoints as follows:

- below 2 825 kHz on a dB/log(*f*) basis; and
- above 2 825 kHz on a dB/*f* basis.

B.2.3 VTU-O Limit PSD masks for band plans 997 (and its extensions)

The VTU-O limit PSD masks for band plan 997 (and its extensions) are shown in Table B.5.

Table B.5 – VTU-O Limit PSD masks for band plan 997 (and its extensions)

Name	B7-1	B7-3	B7-9	B7-10
Long name	997-M1c-A-7	997-M1x-M	997E17-M2x-A	997E30-M2x-NUS0
kHz	dBm/Hz	dBm/Hz	dBm/Hz	dBm/Hz
0	-97.5	-97.5	-97.5	-97.5
4	-97.5	-97.5	-97.5	-97.5
4	-92.5	-92.5	-92.5	-92.5
80	-72.5	-92.5	-72.5	-72.5

Table B.5 – VTU-O Limit PSD masks for band plan 997 (and its extensions)

Name	B7-1	B7-3	B7-9	B7-10
Long name	997-M1c-A-7	997-M1x-M	997E17-M2x-A	997E30-M2x-NUS0
kHz	dBm/Hz	dBm/Hz	dBm/Hz	dBm/Hz
101.2	Interp	-92.5	Interp	Interp
138	-49.5	Interp	-44.2	-44.2
138	-49.5	Interp	-36.5	-36.5
227.11	-49.5	-62	-36.5	-36.5
276	-49.5	-48.5	-36.5	-36.5
276	-49.5	-36.5	-36.5	-36.5
1 104	-49.5	-36.5	-36.5	-36.5
1 622	-49.5	-46.5	-46.5	-46.5
2 208	-49.5	-48	Interp	Interp
2 236	-49.5	Interp	Interp	Interp
2 249	-49.5	-49.5	Interp	Interp
2 423	-56.5	Interp	Interp	Interp
2 500	-56.5	-56.5	Interp	Interp
3 000	-56.5	-56.5	-49.6	-49.6
3 000	-80	-80	-80	-80
3 175	-100	-100	-100	-100
4 925	-100	-100	-100	-100
5 100	-80	-80	-80	-80
5 100	-56.5	-56.5	-52.6	-52.6
5 200	-56.5	-56.5	Interp	Interp
6 875	-56.5	-56.5	Interp	Interp
7 050	-56.5	-56.5	-54	-54
7 050	-80	-80	-80	-80
7 225	-100	-100	-100	-100
10 125	-100	-100	-100	-100
10 125	-100	-100	-100	-100
10 300	-100	-100	-100	-100
11 825	-100	-100	-100	-100
12 000	-100	-100	-80	-80
12 000	-100	-100	-56.5	-56.5
13 825	-100	-100	-56.5	-56.5
14 000	-100	-100	-56.5	-56.5
14 000	-100	-100	-80	-80
14 175	-100	-100	-100	-100
17 489	-100	-100	-100	-100
17 664	-100	-100	-100	-100
17 664	-100	-100	-100	-100

Table B.5 – VTU-O Limit PSD masks for band plan 997 (and its extensions)

Name	B7-1	B7-3	B7-9	B7-10
Long name	997-M1c-A-7	997-M1x-M	997E17-M2x-A	997E30-M2x-NUS0
kHz	dBm/Hz	dBm/Hz	dBm/Hz	dBm/Hz
19 325	-100	-100	-100	-100
19 500	-100	-100	-100	-80
19 500	-100	-100	-100	-56.5
21 000	-100	-100	-100	-56.5
21 450	-100	-100	-100	-56.5
21 450	-100	-100	-100	-56.5
21 625	-100	-100	-100	-56.5
24 715	-100	-100	-100	-56.5
24 890	-100	-100	-100	-56.5
24 890	-100	-100	-100	-56.5
27 000	-100	-100	-100	-56.5
27 000	-100	-100	-100	-80
27 175	-100	-100	-100	-100
30 000	-100	-100	-100	-100
30 000	-110	-110	-110	-110
30 175	-110	-110	-110	-110
> 30 175	-110	-110	-110	-110

NOTE – The PSD values between breakpoints including the values marked by "Interp" shall be obtained by interpolation between adjacent breakpoints as follows:

- below f_i on a dB/log(f) basis; and
- above f_i on a dB/ f basis.

B.2.4 VTU-R limit PSD masks for band plan 998 (and its extensions)

The VTU-R limit PSD masks for band plan 998 (and its extensions) with a highest used upstream or downstream frequency of 12 MHz or 17.664 MHz (see Table B.3 for the band plan 998 PSD mask options) are shown in Table B.6A.

**Table B.6A – VTU-R limit PSD masks for band plan 998 (and its extensions)
with a highest used frequency of 12 MHz or 17.664 MHz**

Name	B8-4	B8-5	B8-6	B8-7	B8-8	B8-9	B8-10	B8-11	B8-12	B8-17	B8-18
Long name	998-M2x-A	998-M2x-M	998-M2x-B	998-M2x-NUS0	998 E17-M2x-NUS0	998 E17-M2x-NUS0-M	998 ADE17-M2x-NUS0-M	998 ADE17-M2x-A	998 ADE17-M2x-B	998 ADE17-M2x-M	998 E17-M2x-A
kHz	dBm/Hz	dBm/Hz	dBm/Hz	dBm/Hz	dBm/Hz	dBm/Hz	dBm/Hz	dBm/Hz	dBm/Hz	dBm/Hz	dBm/Hz
0	-97.5	-97.5	-97.5	-100	-100	-100	-100	-97.5	-97.5	-97.5	-97.5
4	-97.5	-97.5	-97.5	-100	-100	-100	-100	-97.5	-97.5	-97.5	-97.5
4	-92.5	-92.5	-92.5	-100	-100	-100	-100	-92.5	-92.5	-92.5	-92.5
25.875	-34.5	-37.5	-92.5	-100	-100	-100	-100	-34.5	-92.5	-37.5	-34.5
50	-34.5	-37.5	-90	-100	-100	-100	-100	-34.5	-90	-37.5	-34.5
80	-34.5	-37.5	-81.8	-100	-100	-100	-100	-34.5	-81.8	-37.5	-34.5
120	-34.5	-37.5	-34.5	-100	-100	-100	-100	-34.5	-34.5	-37.5	-34.5
138	-34.5	-37.5	-34.5	-100	-100	-100	-100	-34.5	-34.5	-37.5	-34.5
225	Interp	-37.5	-34.5	-100	-100	-100	-100	Interp	-34.5	-37.5	Interp
243	-93.2	-37.5	-34.5	-100	-100	-100	-100	-93.2	-34.5	-37.5	-93.2
276	Interp	-37.5	-34.5	-100	-100	-100	-100	Interp	-34.5	-37.5	Interp
493.41	Interp	-97.9	Interp	-100	-100	-100	-100	Interp	Interp	-97.9	Interp
508.8	Interp	Interp	-98	-100	-100	-100	-100	Interp	-98	Interp	Interp
686	-100	-100	-100	-100	-100	-100	-100	-100	-100	-100	-100
3 575	-100	-100	-100	-100	-100	-100	-100	-100	-100	-100	-100
3 750	-80	-80	-80	-80	-80	-80	-80	-80	-80	-80	-80

**Table B.6A – VTU-R limit PSD masks for band plan 998 (and its extensions)
with a highest used frequency of 12 MHz or 17.664 MHz**

Name	B8-4	B8-5	B8-6	B8-7	B8-8	B8-9	B8-10	B8-11	B8-12	B8-17	B8-18
Long name	998-M2x-A	998-M2x-M	998-M2x-B	998-M2x-NUS0	998 E17-M2x-NUS0	998 E17-M2x-NUS0-M	998 ADE17-M2x-NUS0-M	998 ADE17-M2x-A	998 ADE17-M2x-B	998 ADE17-M2x-M	998 E17-M2x-A
kHz	dBm/Hz	dBm/Hz	dBm/Hz	dBm/Hz	dBm/Hz	dBm/Hz	dBm/Hz	dBm/Hz	dBm/Hz	dBm/Hz	dBm/Hz
3 750	-51.2	-51.2	-51.2	-51.2	-51.2	-51.2	-51.2	-51.2	-51.2	-51.2	-51.2
5 200	-52.7	-52.7	-52.7	-52.7	-52.7	-52.7	-52.7	-52.7	-52.7	-52.7	-52.7
5 200	-80	-80	-80	-80	-80	-80	-80	-80	-80	-80	-80
5 375	-100	-100	-100	-100	-100	-100	-100	-100	-100	-100	-100
8 325	-100	-100	-100	-100	-100	-100	-100	-100	-100	-100	-100
8 500	-80	-80	-80	-80	-80	-80	-80	-80	-80	-80	-80
8 500	-54.8	-54.8	-54.8	-54.8	-54.8	-54.8	-54.8	-54.8	-54.8	-54.8	-54.8
10 000	-55.5	-55.5	-55.5	-55.5	-55.5	-55.5	-55.5	-55.5	-55.5	-55.5	-55.5
12 000	-55.5	-55.5	-55.5	-55.5	-55.5	-55.5	-55.5	-55.5	-55.5	-55.5	-55.5
12 000	-80	-80	-80	-80	-56.5	-56.5	-80	-80	-80	-80	-56.5
12 175	-100	-100	-100	-100	-56.5	-56.5	-100	-100	-100	-100	-56.5
14 000	-100	-100	-100	-100	-56.5	-56.5	-100	-100	-100	-100	-56.5
14 000	-100	-100	-100	-100	-80	-80	-100	-100	-100	-100	-80
14 175	-100	-100	-100	-100	-100	-100	-100	-100	-100	-100	-100
21 275	-100	-100	-100	-100	-100	-100	-100	-100	-100	-100	-100
30 000	-100	-100	-100	-100	-100	-100	-100	-100	-100	-100	-100
30 000	-110	-110	-110	-110	-110	-110	-110	-110	-110	-110	-110
30 175	-110	-110	-110	-110	-110	-110	-110	-110	-110	-110	-110
> 30 175	-110	-110	-110	-110	-110	-110	-110	-110	-110	-110	-110

NOTE – The PSD values between breakpoints including the values marked by "Interp" shall be obtained by interpolation between adjacent breakpoints as follows:

- below 3 575 kHz on a dB/log(*f*) basis; and
- above 3 575 kHz on a dB/*f* basis.

The VTU-R limit PSD masks for band plan 998 (and its extensions) with a highest used upstream or downstream frequency of 30 MHz or 35.328 MHz (see Table B.3 for the band plan 998 PSD mask options) are shown in Table B.6B.

**Table B.6B – VTU-R limit PSD masks for band plan 998 (and its extensions)
with highest used frequency of 30 MHz or 35.328 MHz**

Name	B8-13	B8-14	B8-15	B8-16	B8-19	B8-20	B8-21	B8-22
Long name	998 E30-M2x-NUS0	998 E30-M2x-NUS0-M	998 ADE30-M2x-NUS0-M	998 ADE30-M2x-NUS0-A	998 E35-M2x-A	998 ADE35-M2x-A	998 ADE35-M2x-B	998 ADE35-M2x-M
kHz	dBm/Hz	dBm/Hz	dBm/Hz	dBm/Hz	dBm/Hz	dBm/Hz	dBm/Hz	dBm/Hz
0	-100	-100	-100	-100	-97.5	-97.5	-97.5	-97.5
4	-100	-100	-100	-100	-97.5	-97.5	-97.5	-97.5
4	-100	-100	-100	-100	-92.5	-92.5	-92.5	-92.5
25.875	-100	-100	-100	-100	-34.5	-34.5	-92.5	-37.5
50	-100	-100	-100	-100	-34.5	-34.5	-90	-37.5
80	-100	-100	-100	-100	-34.5	-34.5	-81.8	-37.5
120	-100	-100	-100	-100	-34.5	-34.5	-34.5	-37.5
138	-100	-100	-100	-100	-34.5	-34.5	-34.5	-37.5
225	-100	-100	-100	-100	Interp	Interp	-34.5	-37.5
243	-100	-100	-100	-100	-93.2	-93.2	-34.5	-37.5
276	-100	-100	-100	-100	Interp	Interp	-34.5	-37.5
493.41	-100	-100	-100	-100	Interp	-97.9	Interp	-97.9
508.8	-100	-100	-100	-100	Interp	Interp	-98	Interp
686	-100	-100	-100	-100	-100	-100	-100	-100
3 575	-100	-100	-100	-100	-100	-100	-100	-100
3 750	-80	-80	-80	-80	-80	-80	-80	-80
3 750	-51.2	-51.2	-51.2	-51.2	-51.2	-51.2	-51.2	-51.2
5 100	Interp	Interp	Interp	Interp	Interp	Interp	Interp	Interp
5 200	-52.7	-52.7	-52.7	-52.7	-52.7	-52.7	-52.7	-52.7

**Table B.6B – VTU-R limit PSD masks for band plan 998 (and its extensions)
with highest used frequency of 30 MHz or 35.328 MHz**

Name	B8-13	B8-14	B8-15	B8-16	B8-19	B8-20	B8-21	B8-22
Long name	998 E30-M2x-NUS0	998 E30-M2x-NUS0-M	998 ADE30-M2x-NUS0-M	998 ADE30-M2x-NUS0-A	998 E35-M2x-A	998 ADE35-M2x-A	998 ADE35-M2x-B	998 ADE35-M2x-M
kHz	dBm/Hz	dBm/Hz	dBm/Hz	dBm/Hz	dBm/Hz	dBm/Hz	dBm/Hz	dBm/Hz
5 200	-80	-80	-80	-80	-80	-80	-80	-80
5 375	-100	-100	-100	-100	-100	-100	-100	-100
8 325	-100	-100	-100	-100	-100	-100	-100	-100
8 500	-80	-80	-80	-80	-80	-80	-80	-80
8 500	-54.8	-54.8	-54.8	-54.8	-54.8	-54.8	-54.8	-54.8
10 000	-55.5	-55.5	-55.5	-55.5	-55.5	-55.5	-55.5	-55.5
12 000	-55.5	-55.5	-55.5	-55.5	-55.5	-55.5	-55.5	-55.5
12 000	-56.5	-56.5	-80	-80	-56.5	-80	-80	-80
12 175	-56.5	-56.5	-100	-100	-56.5	-100	-100	-100
14 000	-56.5	-56.5	-100	-100	-56.5	-100	-100	-100
14 000	-80	-80	-100	-100	-80	-100	-100	-100
14 175	-100	-100	-100	-100	-100	-100	-100	-100
21 275	-100	-100	-100	-100	-100	-100	-100	-100
21 450	-80	-80	-100	-100	-100	-100	-100	-100
21 450	-56.5	-56.5	-100	-100	-100	-100	-100	-100
24 715	-56.5	-56.5	-100	-100	-100	-100	-100	-100
24 890	-56.5	-56.5	-80	-80	-100	-100	-100	-100
24 890	-80	-80	-56.5	-56.5	-100	-100	-100	-100
25 065	-100	-100	-56.5	-56.5	-100	-100	-100	-100
30 000	-100	-100	-56.5	-56.5	-100	-100	-100	-100
30 000	-110	-110	-80	-80	-110	-110	-110	-110
30 175	-110	-110	-110	-110	-110	-110	-110	-110

**Table B.6B – VTU-R limit PSD masks for band plan 998 (and its extensions)
with highest used frequency of 30 MHz or 35.328 MHz**

Name	B8-13	B8-14	B8-15	B8-16	B8-19	B8-20	B8-21	B8-22
Long name	998 E30- M2x- NUS0	998 E30- M2x- NUS0-M	998 ADE30- M2x- NUS0-M	998 ADE30- M2x- NUS0-A	998 E35- M2x-A	998 ADE35- M2x-A	998 ADE35- M2x-B	998 ADE35- M2x-M
kHz	dBm/ Hz	dBm/ Hz	dBm/ Hz	dBm/ Hz	dBm/ Hz	dBm/ Hz	dBm/ Hz	dBm/ Hz
35 328	-110	-110	-110	-110	-110	-110	-110	-110
> 35 328	-110	-110	-110	-110	-110	-110	-110	-110
NOTE – The PSD values between breakpoints including the values marked by "Interp" shall be obtained by interpolation between adjacent breakpoints as follows: – below 3 575 kHz on a dB/log(<i>f</i>) basis; and – above 3 575 kHz on a dB/ <i>f</i> basis.								

B.2.5 VTU-O Limit PSD masks for band plan 998 (and its extensions)

The VTU-O limit PSD masks for band plan 998 (and its extensions) with a highest used upstream or downstream frequency of 12 MHz or 17.664 MHz (see Table B.3 for the band plan 998 PSD mask options) are shown in Table B.7A.

**Table B.7A– VTU-O limit PSD masks for band plan 998 (and its extensions)
with a highest used frequency of 12 MHz or 17.664 MHz**

Name	B8-4	B8-5	B8-6	B8-7	B8-8	B8-9	B8-10	B8-11	B8-12	B8-17	B8-18
Long name	998- M2x-A	998- M2x-M	998- M2x-B	998- M2x- NUS0	998 E17- M2x- NUS0	998 E17- M2x- NUS0-M	998 ADE17- M2x- NUS0-M	998 ADE17- M2x-A	998 ADE17- M2x-B	998 ADE17- M2x-M	998 E17- M2x-A
kHz	dBm/ Hz	dBm/ Hz	dBm/ Hz	dBm/ Hz	dBm/ Hz	dBm/ Hz	dBm/ Hz	dBm/ Hz	dBm/ Hz	dBm/ Hz	dBm/ Hz
0	-97.5	-97.5	-97.5	-97.5	-97.5	-97.5	-97.5	-97.5	-97.5	-97.5	-97.5
4	-97.5	-97.5	-97.5	-97.5	-97.5	-97.5	-97.5	-97.5	-97.5	-97.5	-97.5

**Table B.7A– VTU-O limit PSD masks for band plan 998 (and its extensions)
with a highest used frequency of 12 MHz or 17.664 MHz**

Name	B8-4	B8-5	B8-6	B8-7	B8-8	B8-9	B8-10	B8-11	B8-12	B8-17	B8-18
Long name	998-M2x-A	998-M2x-M	998-M2x-B	998-M2x-NUS0	998 E17-M2x-NUS0	998 E17-M2x-NUS0-M	998 ADE17-M2x-NUS0-M	998 ADE17-M2x-A	998 ADE17-M2x-B	998 ADE17-M2x-M	998 E17-M2x-A
kHz	dBm/Hz	dBm/Hz	dBm/Hz	dBm/Hz	dBm/Hz	dBm/Hz	dBm/Hz	dBm/Hz	dBm/Hz	dBm/Hz	dBm/Hz
4	-92.5	-92.5	-92.5	-92.5	-92.5	-92.5	-92.5	-92.5	-92.5	-92.5	-92.5
80	-72.5	-92.5	-92.5	-72.5	-72.5	-92.5	-92.5	-72.5	-92.5	-92.5	-72.5
101.2	Interp	-92.5	-92.5	Interp	Interp	-92.5	-92.5	Interp	-92.5	-92.5	Interp
138	-44.2	Interp	Interp	-44.2	-44.2	Interp	Interp	-44.2	Interp	Interp	-44.2
138	-36.5	Interp	Interp	-36.5	-36.5	Interp	Interp	-36.5	Interp	Interp	-36.5
227.11	-36.5	-62	-62	-36.5	-36.5	-62	-62	-36.5	-62	-62	-36.5
276	-36.5	-48.5	-48.5	-36.5	-36.5	-48.5	-48.5	-36.5	-48.5	-48.5	-36.5
276	-36.5	-36.5	-36.5	-36.5	-36.5	-36.5	-36.5	-36.5	-36.5	-36.5	-36.5
1 104	-36.5	-36.5	-36.5	-36.5	-36.5	-36.5	-36.5	-36.5	-36.5	-36.5	-36.5
1 622	-46.5	-46.5	-46.5	-46.5	-46.5	-46.5	-46.5	-46.5	-46.5	-46.5	-46.5
2 208	-48	-48	-48	-48	-48	-48	-48	-48	-48	-48	-48
2 249	Interp	Interp	Interp	Interp	Interp	Interp	Interp	Interp	Interp	Interp	Interp
2 500	Interp	Interp	Interp	Interp	Interp	Interp	Interp	Interp	Interp	Interp	Interp
3 750	-51.2	-51.2	-51.2	-51.2	-51.2	-51.2	-51.2	-51.2	-51.2	-51.2	-51.2
3 750	-80	-80	-80	-80	-80	-80	-80	-80	-80	-80	-80
3 925	-100	-100	-100	-100	-100	-100	-100	-100	-100	-100	-100
5 025	-100	-100	-100	-100	-100	-100	-100	-100	-100	-100	-100
5 200	-80	-80	-80	-80	-80	-80	-80	-80	-80	-80	-80
5 200	-52.7	-52.7	-52.7	-52.7	-52.7	-52.7	-52.7	-52.7	-52.7	-52.7	-52.7
8 500	-54.8	-54.8	-54.8	-54.8	-54.8	-54.8	-54.8	-54.8	-54.8	-54.8	-54.8
8 500	-80	-80	-80	-80	-80	-80	-80	-80	-80	-80	-80

**Table B.7A– VTU-O limit PSD masks for band plan 998 (and its extensions)
with a highest used frequency of 12 MHz or 17.664 MHz**

Name	B8-4	B8-5	B8-6	B8-7	B8-8	B8-9	B8-10	B8-11	B8-12	B8-17	B8-18
Long name	998-M2x-A	998-M2x-M	998-M2x-B	998-M2x-NUS0	998 E17-M2x-NUS0	998 E17-M2x-NUS0-M	998 ADE17-M2x-NUS0-M	998 ADE17-M2x-A	998 ADE17-M2x-B	998 ADE17-M2x-M	998 E17-M2x-A
kHz	dBm/Hz	dBm/Hz	dBm/Hz	dBm/Hz	dBm/Hz	dBm/Hz	dBm/Hz	dBm/Hz	dBm/Hz	dBm/Hz	dBm/Hz
8 675	-100	-100	-100	-100	-100	-100	-100	-100	-100	-100	-100
11 825	-100	-100	-100	-100	-100	-100	-100	-100	-100	-100	-100
12 000	-100	-100	-100	-100	-100	-100	-80	-80	-80	-80	-100
12 000	-100	-100	-100	-100	-100	-100	-56.5	-56.5	-56.5	-56.5	-100
13 825	-100	-100	-100	-100	-100	-100	-56.5	-56.5	-56.5	-56.5	-100
14 000	-100	-100	-100	-100	-80	-80	-56.5	-56.5	-56.5	-56.5	-80
14 000	-100	-100	-100	-100	-56.5	-56.5	-56.5	-56.5	-56.5	-56.5	-56.5
17 664	-100	-100	-100	-100	-56.5	-56.5	-56.5	-56.5	-56.5	-56.5	-56.5
21 000	-100	-100	-100	-100	-80	-80	-80	-80	-80	-80	-80
21 450	-100	-100	-100	-100	-100	-100	-100	-100	-100	-100	-100
30 000	-100	-100	-100	-100	-100	-100	-100	-100	-100	-100	-100
30 000	-110	-110	-110	-110	-110	-110	-110	-110	-110	-110	-110
30 175	-110	-110	-110	-110	-110	-110	-110	-110	-110	-110	-110
> 30 175	-110	-110	-110	-110	-110	-110	-110	-110	-110	-110	-110

NOTE – The PSD values between breakpoints including the values marked by "Interp" shall be obtained by interpolation between adjacent breakpoints as follows:

- below f_i on a dB/log(f) basis; and
- above f_i on a dB/ f basis,

where f_i is defined in Table B.1 as either 138 kHz or 276 kHz.

The VTU-O limit PSD masks for band plan 998 (and its extensions) with a highest used upstream or downstream frequency of 30 MHz or 35.328 MHz (see Table B.3 for the band plan 998 PSD mask options) are shown in Table B.7B.

**Table B.7B – VTU-O limit PSD masks for band plan 998 (and its extensions)
with a highest used frequency of 30 MHz or 35.328 MHz**

Name	B8-13	B8-14	B8-15	B8-16	B8-19	B8-20	B8-21	B8-22
Long name	998 E30-M2x-NUS0	998 E30-M2x-NUS0-M	998 ADE30-M2x-NUS0-M	998 ADE30-M2x-NUS0-A	998 E35-M2x-A	998 ADE35-M2x-A	998 ADE35-M2x-B	998 ADE35-M2x-M
kHz	dBm/Hz	dBm/Hz	dBm/Hz	dBm/Hz	dBm/Hz	dBm/Hz	dBm/Hz	dBm/Hz
0	-97.5	-97.5	-97.5	-97.5	-97.5	-97.5	-97.5	-97.5
4	-97.5	-97.5	-97.5	-97.5	-97.5	-97.5	-97.5	-97.5
4	-92.5	-92.5	-92.5	-92.5	-92.5	-92.5	-92.5	-92.5
80	-72.5	-92.5	-92.5	-72.5	-72.5	-72.5	-92.5	-92.5
101.2	Interp	-92.5	-92.5	Interp	Interp	Interp	-92.5	-92.5
138	-44.2	Interp	Interp	-44.2	-44.2	-44.2	Interp	Interp
138	-36.5	Interp	Interp	-36.5	-36.5	-36.5	Interp	Interp
227.11	-36.5	-62	-62	-36.5	-36.5	-36.5	-62	-62
276	-36.5	-48.5	-48.5	-36.5	-36.5	-36.5	-48.5	-48.5
276	-36.5	-36.5	-36.5	-36.5	-36.5	-36.5	-36.5	-36.5
1 104	-36.5	-36.5	-36.5	-36.5	-36.5	-36.5	-36.5	-36.5
1 622	-46.5	-46.5	-46.5	-46.5	-46.5	-46.5	-46.5	-46.5
2 208	-48	-48	-48	-48	-48	-48	-48	-48
3 750	-51.2	-51.2	-51.2	-51.2	-51.2	-51.2	-51.2	-51.2
3 750	-80	-80	-80	-80	-80	-80	-80	-80
3 925	-100	-100	-100	-100	-100	-100	-100	-100
5 025	-100	-100	-100	-100	-100	-100	-100	-100
5 200	-80	-80	-80	-80	-80	-80	-80	-80
5 200	-52.7	-52.7	-52.7	-52.7	-52.7	-52.7	-52.7	-52.7
8 500	-54.8	-54.8	-54.8	-54.8	-54.8	-54.8	-54.8	-54.8
8 500	-80	-80	-80	-80	-80	-80	-80	-80
8 675	-100	-100	-100	-100	-100	-100	-100	-100

**Table B.7B – VTU-O limit PSD masks for band plan 998 (and its extensions)
with a highest used frequency of 30 MHz or 35.328 MHz**

Name	B8-13	B8-14	B8-15	B8-16	B8-19	B8-20	B8-21	B8-22
Long name	998 E30-M2x-NUS0	998 E30-M2x-NUS0-M	998 ADE30-M2x-NUS0-M	998 ADE30-M2x-NUS0-A	998 E35-M2x-A	998 ADE35-M2x-A	998 ADE35-M2x-B	998 ADE35-M2x-M
kHz	dBm/Hz	dBm/Hz	dBm/Hz	dBm/Hz	dBm/Hz	dBm/Hz	dBm/Hz	dBm/Hz
11 825	-100	-100	-100	-100	-100	-100	-100	-100
12 000	-100	-100	-80	-80	-100	-80	-80	-80
12 000	-100	-100	-56.5	-56.5	-100	-56.5	-56.5	-56.5
13 825	-100	-100	-56.5	-56.5	-100	-56.5	-56.5	-56.5
14 000	-80	-80	-56.5	-56.5	-80	-56.5	-56.5	-56.5
14 000	-56.5	-56.5	-56.5	-56.5	-56.5	-56.5	-56.5	-56.5
21 450	-56.5	-56.5	-56.5	-56.5	-56.5	-56.5	-56.5	-56.5
21 450	-80	-80	-56.5	-56.5	-56.5	-56.5	-56.5	-56.5
21 625	-100	-100	-56.5	-56.5	-56.5	-56.5	-56.5	-56.5
24 715	-100	-100	-56.5	-56.5	-56.5	-56.5	-56.5	-56.5
24 890	-80	-80	-56.5	-56.5	-56.5	-56.5	-56.5	-56.5
24 890	-56.5	-56.5	-80	-80	-56.5	-56.5	-56.5	-56.5
25 065	-56.5	-56.5	-100	-100	-56.5	-56.5	-56.5	-56.5
30 000	-56.5	-56.5	-100	-100	-56.5	-56.5	-56.5	-56.5
30 000	-80	-80	-110	-110	-73	-73	-73	-73
30 175	-110	-110	-110	-110	Interp	Interp	Interp	Interp
35 328	-110	-110	-110	-110	-73.4	-73.4	-73.4	-73.4
37 000	-110	-110	-110	-110	-83	-83	-83	-83
40 656	-110	-110	-110	-110	-110	-110	-110	-110
> 40 656	-110	-110	-110	-110	-110	-110	-110	-110

NOTE – The PSD values between breakpoints including the values marked by "Interp" shall be obtained by interpolation between adjacent breakpoints as follows:

**Table B.7B – VTU-O limit PSD masks for band plan 998 (and its extensions)
with a highest used frequency of 30 MHz or 35.328 MHz**

Name	B8-13	B8-14	B8-15	B8-16	B8-19	B8-20	B8-21	B8-22
Long name	998 E30- M2x- NUS0	998 E30- M2x- NUS0-M	998 ADE30- M2x- NUS0-M	998 ADE30- M2x- NUS0-A	998 E35- M2x-A	998 ADE35- M2x-A	998 ADE35- M2x-B	998 ADE35- M2x-M
kHz	dBm/ Hz	dBm/ Hz	dBm/ Hz	dBm/ Hz	dBm/ Hz	dBm/ Hz	dBm/ Hz	dBm/ Hz
– below f_1 on a dB/log(f) basis; and – above f_1 on a dB/ f basis, where f_1 is defined in Table B.1 as either 138 kHz or 276 kHz.								

B.3 UPBO reference PSDs

UPBO parameters '*a*' and '*b*' are set by network management.

NOTE – The parameters '*a*' and '*b*' are expected to be uniform across all lines sharing a section of cable plant.

B.4 Template PSD

B.4.1 Definition

The Template PSD is set to 3.5 dB below the PSD mask in frequency bands in which the PSD is at or above -96.5 dBm/Hz. Elsewhere the template is set to -100 dBm/Hz below 4 MHz, -110 dBm/Hz between 4 MHz and f_3 , or -112 dBm/Hz between f_3 and 35.328 MHz, where f_3 is defined in Table B.1. These values are chosen to satisfy the requirements of clause 7.2.2.

B.4.2 Narrow-band PSD verification

Narrow-band compliance with the PSD masks in this annex shall be verified by power measurements using a 10-kHz measurement bandwidth centred on the frequency in question above 4 kHz, and in a 100-Hz measurement bandwidth in the band up to 4 kHz.

B.4.3 Use in simulation (Informative)

The Template PSD may be used in simulations of VDSL2 performance as representative of an average transmitter conformant with the associated Limit PSD mask.

B.5 Compliance

Compliance requires conformance with at least one Limit PSD mask.

Annex C

Region C (Japan)

(This annex forms an integral part of this Recommendation.)

C.1 Band plan

The band plan shall be specified as shown in Figure C.1. According to the profiles defined in Table 6-1, adequate subsets of US0, DS1, US1, DS2, US2, DS3, and US3 shall be selected. The transition frequency between US0 and DS1 is 138 kHz or 276 kHz as defined in C.2.1.

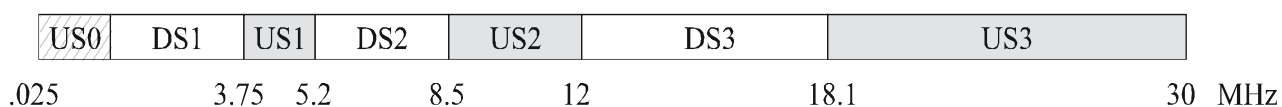

Figure C.1 – The band plan between 25 kHz and 30 MHz

C.2 Limit PSD masks

C.2.1 VDSL2 system operating at frequencies above the POTS band

The frequencies above 25 kHz are used for VDSL2. The downstream PSD shall comply with the Limit PSD masks defined in Table C.1, Table C.2, Table C.5 or Table C.6 and the upstream PSD shall comply with the Limit PSD masks defined in Table C.3, Table C.4, Table C.7 or Table C.8. Other PSD limitations are for further study.

Table C.1 – VTU-O limit PSD mask (VDSL2 above POTS band; 25-138 kHz Type(b))

Band attribute	Frequency band f (MHz)	Limit PSD mask level (dBm/Hz)	Maximum power limitation in a 1-MHz sliding window (dBm)
DS1	$0 < f < 0.12$	-120	-
	$0.12 \leq f \leq 0.138$	$-60 + (50/0.018) \times (f - 0.138)$	-
	$0.138 < f < 3.75$	$-60 + 3.5 (= -56.5)$	-
	$3.75 \leq f \leq 3.925$	$-80 - (20/0.175) \times (f - 3.75)$	-
	$3.925 < f < 5.025$	-100	-50
	$5.025 \leq f \leq 5.2$	$-80 + (20/0.175) \times (f - 5.2)$	-
DS2	$5.2 < f < 8.5$	$-60 + 3.5 (= -56.5)$	-
	$8.5 \leq f \leq 8.675$	$-80 - (20/0.175) \times (f - 8.5)$	-
	$8.675 < f < 11.825$	-100	-52
	$11.825 \leq f \leq 12$	$-80 + (20/0.175) \times (f - 12)$	-

Table C.1 – VTU-O limit PSD mask (VDSL2 above POTS band; 25-138 kHz Type(b))

Band attribute	Frequency band f (MHz)	Limit PSD mask level (dBm/Hz)	Maximum power limitation in a 1-MHz sliding window (dBm)
DS3	$12 < f < 18.1$	$-60 + 3.5 (= -56.5)$	–
	$18.1 \leq f \leq 18.275$	$-80 - (20/0.175) \times (f - 18.1)$	–
	$18.275 < f < 30$	–100	–52
	$30 \leq f$	–110	–

NOTE 1 – All PSD and power measurements are in 100 Ω .

NOTE 2 – The limit PSD mask level shall be measured with a 10-kHz resolution bandwidth.

NOTE 3 – The maximum power in a 1-MHz sliding window shall be measured with a 1-MHz resolution bandwidth.

NOTE 4 – The requirements for the stopband PSD are compliant with clause 7.2.2.

Table C.2 – VTU-O limit PSD mask (VDSL2 above POTS band; 25-276 kHz Type(b))

Band attribute	Frequency band f (MHz)	Limit PSD mask level (dBm/Hz)	Maximum power limitation in a 1-MHz sliding window (dBm)
DS1	$0 < f < 0.12$	–120	–
	$0.12 \leq f < 0.225$	–110	–
	$0.225 \leq f \leq 0.276$	$-60 + (50/0.051) \times (f - 0.276)$	–
	$0.276 < f < 3.75$	$-60 + 3.5 (= -56.5)$	–
	$3.75 \leq f \leq 3.925$	$-80 - (20/0.175) \times (f - 3.75)$	–
	$3.925 < f < 5.025$	–100	–50
	$5.025 \leq f \leq 5.2$	$-80 + (20/0.175) \times (f - 5.2)$	–
DS2	$5.2 < f < 8.5$	$-60 + 3.5 (= -56.5)$	–
	$8.5 \leq f \leq 8.675$	$-80 - (20/0.175) \times (f - 8.5)$	–
	$8.675 < f < 11.825$	–100	–52
	$11.825 \leq f \leq 12$	$-80 + (20/0.175) \times (f - 12)$	–
DS3	$12 < f < 18.1$	$-60 + 3.5 (= -56.5)$	–
	$18.1 \leq f \leq 18.275$	$-80 - (20/0.175) \times (f - 18.1)$	–
	$18.275 < f < 30$	–100	–52
	$30 \leq f$	–110	–

NOTE 1 – All PSD and power measurements are in 100 Ω .

NOTE 2 – The limit PSD mask level shall be measured with a 10-kHz resolution bandwidth.

NOTE 3 – The maximum power in a 1-MHz sliding window shall be measured with a 1-MHz resolution bandwidth.

NOTE 4 – The requirements for the stopband PSD are compliant with clause 7.2.2.

Table C.3 – VTU-R Limit PSD mask (VDSL2 above POTS band; 25-138 kHz Type(b))

Band attribute	Frequency band f (MHz)	Limit PSD mask level (dBm/Hz)	Maximum power limitation in a 1-MHz sliding window (dBm)
US0	$0 < f < 0.004$	-97.5	–
	$0.004 \leq f \leq 0.025875$	$-92.5 + 13.4 \times \log_2(f/0.004)$	–
	$0.025875 < f < 0.138$	$-60 + 3.5 (= -56.5)$	–
	$0.138 \leq f \leq 0.210$	$-56.5 - 72 \times \log_2(f/0.138)$	–
	$0.210 < f < 3.575$	100	–
	$3.575 \leq f \leq 3.75$	$-80 + (20/0.175) \times (f - 3.75)$	–
US1	$3.75 < f < 5.2$	$-60 + 3.5 (= -56.5)$	–
	$5.2 \leq f \leq 5.375$	$-80 - (20/0.175) \times (f - 5.2)$	–
	$5.375 < f < 8.325$	-100	-52
	$8.325 \leq f \leq 8.5$	$-80 + (20/0.175) \times (f - 8.5)$	–
US2	$8.5 < f < 12$	$-60 + 3.5 (= -56.5)$	–
	$12 \leq f \leq 12.175$	$-80 - (20/0.175) \times (f - 12)$	–
	$12.175 < f < 17.925$	-100	-52
	$17.925 \leq f \leq 18.1$	$-80 + (20/0.175) \times (f - 18.1)$	–
US3	$18.1 < f < 30$	$-60 + 3.5 (= -56.5)$	–
	$30 \leq f \leq 30.175$	$-80 - (30/0.175) \times (f - 30)$	–
	$30.175 < f$	-110	–

NOTE 1 – All PSD and power measurements are in 100 Ω .

NOTE 2 – The limit PSD mask level shall be measured with a 10-kHz resolution bandwidth.

NOTE 3 – The maximum power in a 1-MHz sliding window shall be measured with a 1-MHz resolution bandwidth.

NOTE 4 – The requirements for the stopband PSD are compliant with clause 7.2.2.

Table C.4 – VTU-R Limit PSD mask (VDSL2 above POTS band; 25-276 kHz Type(b))

Band attribute	Frequency band f (MHz)	Limit PSD mask level (dBm/Hz)	Maximum power limitation in a 1-MHz sliding window (dBm)
US0	$0 < f < 0.004$	-97.5	–
	$0.004 \leq f \leq 0.025875$	$-92.5 + 13.4 \times \log_2(f/0.004)$	–
	$0.025875 < f < 0.276$	$-60 + 3.5 (= -56.5)$	–
	$0.276 \leq f \leq 0.420$	$-56.5 - 72 \times \log_2(f/0.276)$	–
	$0.420 < f < 3.575$	-100	–
	$3.575 \leq f \leq 3.75$	$-80 + (20/0.175) \times (f - 3.75)$	–
US1	$3.75 < f < 5.2$	$-60 + 3.5 (= -56.5)$	–
	$5.2 \leq f \leq 5.375$	$-80 - (20/0.175) \times (f - 5.2)$	–
	$5.375 < f < 8.325$	-100	-52
	$8.325 \leq f \leq 8.5$	$-80 + (20/0.175) \times (f - 8.5)$	–
US2	$8.5 < f < 12$	$-60 + 3.5 (= -56.5)$	–
	$12 \leq f \leq 12.175$	$-80 - (20/0.175) \times (f - 12)$	–
	$12.175 < f < 17.925$	-100	-52
	$17.925 \leq f \leq 18.1$	$-80 + (20/0.175) \times (f - 18.1)$	–
US3	$18.1 < f < 30$	$-60 + 3.5 (= -56.5)$	–
	$30 \leq f \leq 30.175$	$-80 - (30/0.175) \times (f - 30)$	–
	$30.175 < f$	-110	–

NOTE 1 – All PSD and power measurements are in 100 Ω .

NOTE 2 – The Limit PSD mask level shall be measured with a 10-kHz resolution bandwidth.

NOTE 3 – The maximum power in a 1-MHz sliding window shall be measured with a 1-MHz resolution bandwidth.

NOTE 4 – The requirements for the stopband PSD are compliant with clause 7.2.2.

Table C.5 – VTU-O Limit PSD mask (VDSL2 above POTS band; 25-138 kHz Type(co))

Band attribute	Frequency band f (MHz)	Limit PSD mask level (dBm/Hz)	Maximum power limitation in a 1-MHz sliding window (dBm)
DS1	$0 < f < 0.004$	-97.5	–
	$0.004 \leq f < 0.08$	$-92.5 + 4.63 \times \log_2(f/0.004)$	–
	$0.08 \leq f \leq 0.138$	$-72.5 + 36 \times \log_2(f/0.08)$	–
	$0.138 < f \leq 1.104$	$-40 + 3.5 (= -36.5)$	–
	$1.104 < f < 1.622$	$-36.5 - 18 \times \log_2(f/1.104)$	–
	$1.622 \leq f < 3.75$	$-46.5 - 2.9 \times \log_2(f/1.622)$	–
	$3.75 \leq f \leq 3.925$	$-80 - (20/0.175) \times (f - 3.75)$	–
	$3.925 < f < 5.025$	-100	-50
DS2	$5.025 \leq f \leq 5.2$	$-80 + (20/0.175) \times (f - 5.2)$	–
	$5.2 < f < 8.5$	$-55 + 3.5 (= -51.5)$	–
	$8.5 \leq f \leq 8.675$	$-80 - (20/0.175) \times (f - 8.5)$	–
	$8.675 < f < 30$	-100	-52
	$30 \leq f$	-110	–

NOTE 1 – All PSD and power measurements are in 100 Ω .
 NOTE 2 – The Limit PSD mask level shall be measured with a 10-kHz resolution bandwidth.
 NOTE 3 – The maximum power in a 1-MHz sliding window shall be measured with a 1-MHz resolution bandwidth.
 NOTE 4 – The requirements for the stopband PSD are compliant with clause 7.2.2.

Table C.6 – VTU-O Limit PSD mask (VDSL2 above POTS band; 25-276 kHz Type(co))

Band attribute	Frequency band f (MHz)	Limit PSD mask level (dBm/Hz)	Maximum power limitation in a 1-MHz sliding window (dBm)
DS1	$0 < f < 0.004$	-97.5	–
	$0.004 \leq f < 0.1012$	-90	–
	$0.1012 \leq f < 0.2271$	$-90 + 24 \times \log_2(f/0.1012)$	–
	$0.2271 \leq f \leq 0.276$	$-62 + 63 \times \log_2(f/0.2271)$	–
	$0.276 < f \leq 1.104$	$-40 + 3.5 (= -36.5)$	–
	$1.104 < f < 1.622$	$-36.5 - 18 \times \log_2(f/1.104)$	–
	$1.622 \leq f < 3.75$	$-46.5 - 2.9 \times \log_2(f/1.622)$	–
	$3.75 \leq f \leq 3.925$	$-80 - (20/0.175) \times (f - 3.75)$	–
	$3.925 < f < 5.025$	-100	-50
	$5.025 \leq f \leq 5.2$	$-80 + (20/0.175) \times (f - 5.2)$	–

Table C.6 – VTU-O Limit PSD mask (VDSL2 above POTS band; 25-276 kHz Type(co))

Band attribute	Frequency band f (MHz)	Limit PSD mask level (dBm/Hz)	Maximum power limitation in a 1-MHz sliding window (dBm)
DS2	$5.2 < f < 8.5$	$-55 + 3.5 (= -51.5)$	–
	$8.5 \leq f \leq 8.675$	$-80 - (20/0.175) \times (f - 8.5)$	–
	$8.675 < f < 30$	–100	–52
	$30 \leq f$	–110	–

NOTE 1 – All PSD and power measurements are in 100 Ω .

NOTE 2 – The Limit PSD mask level shall be measured with a 10-kHz resolution bandwidth.

NOTE 3 – The maximum power in a 1-MHz sliding window shall be measured with a 1-MHz resolution bandwidth.

NOTE 4 – The requirements for the stopband PSD are compliant with clause 7.2.2.

Table C.7 – VTU-R Limit PSD mask (VDSL2 above POTS bands; 25-138 kHz Type(co))

Band attribute	Frequency band f (MHz)	Limit PSD mask level (dBm/Hz)	Maximum power limitation in a 1-MHz sliding window (dBm)
US0	$0 < f < 0.004$	–97.5	–
	$0.004 \leq f \leq 0.025875$	$-92.5 + 21.5 \times \log_2(f/0.004)$	–
	$0.025875 < f < 0.138$	$-38 + 3.5 (= -34.5)$	–
	$0.138 \leq f < 0.24292$	$-34.5 - 72 \times \log_2(f/0.138)$	–
	$0.24292 \leq f \leq 0.686$	$-93.2 - 15 \times \log_{10}(f/0.24292)$	–
	$0.686 < f < 3.575$	–100	–
	$3.575 \leq f \leq 3.75$	$-80 + (20/0.175) \times (f - 3.75)$	–
US1	$3.75 < f < 5.2$	$-53 + 3.5 (= -49.5)$	–
	$5.2 \leq f \leq 5.375$	$-80 - (20/0.175) \times (f - 5.2)$	–
	$5.375 < f < 8.325$	–100	–52
	$8.325 \leq f \leq 8.5$	$-80 + (20/0.175) \times (f - 8.5)$	–

Table C.7 – VTU-R Limit PSD mask (VDSL2 above POTS bands; 25-138 kHz Type(co))

Band attribute	Frequency band f (MHz)	Limit PSD mask level (dBm/Hz)	Maximum power limitation in a 1-MHz sliding window (dBm)
US2	$8.5 < f < 12$	$-54 + 3.5 (= -50.5)$	–
	$12 \leq f \leq 12.175$	$-80 - (20/0.175) \times (f - 12)$	–
	$12.175 < f < 30$	–100	–52
	$30 \leq f$	–110	–

NOTE 1 – All PSD and power measurements are in 100 Ω .

NOTE 2 – The Limit PSD mask level shall be measured with a 10-kHz resolution bandwidth.

NOTE 3 – The maximum power in a 1-MHz sliding window shall be measured with a 1-MHz resolution bandwidth.

NOTE 4 – The requirements for the stopband PSD are compliant with clause 7.2.2.

Table C.8 – VTU-R Limit PSD mask (VDSL2 above POTS band; 25-276 kHz Type(co))

Band attribute	Frequency band f (MHz)	Limit PSD mask level (dBm/Hz)	Maximum power limitation in a 1-MHz sliding window (dBm)
US0	$0 < f < 0.004$	–97.5	–
	$0.004 \leq f \leq 0.025875$	$-92.5 + 20.4 \times \log_2(f/0.004)$	–
	$0.025875 < f < 0.276$	$-41 + 3.5 (= -37.5)$	–
	$0.276 \leq f < 0.49341$	$-37.5 - 72 \times \log_2(f/0.276)$	–
	$0.49341 \leq f \leq 0.686$	$-97.9 - 15 \times \log_{10}(f/0.49341)$	–
	$0.686 < f < 3.575$	–100	–
	$3.575 \leq f \leq 3.75$	$-80 + (20/0.175) \times (f - 3.75)$	–
US1	$3.75 < f < 5.2$	$-53 + 3.5 (= -49.5)$	–
	$5.2 \leq f \leq 5.375$	$-80 - (20/0.175) \times (f - 5.2)$	–
	$5.375 < f < 8.325$	–100	–52
	$8.325 \leq f \leq 8.5$	$-80 + (20/0.175) \times (f - 8.5)$	–

Table C.8 – VTU-R Limit PSD mask (VDSL2 above POTS band; 25-276 kHz Type(co))

Band attribute	Frequency band f (MHz)	Limit PSD mask level (dBm/Hz)	Maximum power limitation in a 1-MHz sliding window (dBm)
US2	$8.5 < f < 12$	$-54 + 3.5 (= -50.5)$	–
	$12 \leq f \leq 12.175$	$-80 - (20/0.175) \times (f - 12)$	–
	$12.175 < f < 30$	–100	–52
	$30 \leq f$	–110	–

NOTE 1 – All PSD and power measurements are in 100 Ω .

NOTE 2 – The Limit PSD mask level shall be measured with a 10-kHz resolution bandwidth.

NOTE 3 – The maximum power in a 1-MHz sliding window shall be measured with a 1-MHz resolution bandwidth.

NOTE 4 – The requirements for the stopband PSD are compliant with clause 7.2.2.

C.2.2 VDSL2 system operating at frequencies above the TCM-ISDN DSL band

The frequencies above 640 kHz are used for VDSL2. The frequencies below 320 kHz are used for TCM-ISDN DSL. The band between 320 kHz and 640 kHz is a guard band. US0 shall not be used and DS1 shall start at 640 kHz.

The Limit PSD masks are defined in Tables C.9 and C.10 below. Other PSDs are for further study.

Table C.9 – VTU-O Limit PSD mask (VDSL2 above TCM-ISDN band)

Band attribute	Frequency band f (MHz)	Limit PSD mask level (dBm/Hz) (Notes 1, 2 and 4)	Maximum power limitation in a 1-MHz sliding window (dBm) (Notes 1, 3 and 4)
DS1	$0 < f < 0.12$	–120	
	$0.12 \leq f < 0.225$	–110	
	$0.225 \leq f < 0.465$	–100	
	$0.465 \leq f \leq 0.640$	$-60 + (40/0.175) \times (f - 0.64)$	
	$0.640 < f < 3.75$	$-60 + 3.5 (= -56.5)$	
	$3.75 \leq f \leq 3.925$	$-80 - (20/0.175) \times (f - 3.75)$	
	$3.925 < f < 5.025$	–100	–50
	$5.025 \leq f \leq 5.2$	$-80 + (20/0.175) \times (f - 5.2)$	
DS2	$5.2 < f < 8.5$	$-60 + 3.5 (= -56.5)$	
	$8.5 \leq f \leq 8.675$	$-80 - (20/0.175) \times (f - 8.5)$	
	$8.675 < f < 11.825$	–100	–52
	$11.825 \leq f \leq 12$	$-80 + (20/0.175) \times (f - 12)$	

Table C.9 – VTU-O Limit PSD mask (VDSL2 above TCM-ISDN band)

Band attribute	Frequency band f (MHz)	Limit PSD mask level (dBm/Hz) (Notes 1, 2 and 4)	Maximum power limitation in a 1-MHz sliding window (dBm) (Notes 1, 3 and 4)
DS3	$12 < f < 18.1$	$-60 + 3.5 (= -56.5)$	
	$18.1 \leq f \leq 18.275$	$-80 - (20/0.175) \times (f - 18.1)$	
	$18.275 < f < 30$	-100	-52
	$30 \leq f$	-110	

NOTE 1 – All PSD and power measurements are into 100 Ω .
 NOTE 2 – The Limit PSD mask level shall be measured with a 10-kHz resolution bandwidth.
 NOTE 3 – The maximum power in a 1-MHz sliding window shall be measured with a 1-MHz resolution bandwidth.
 NOTE 4 – The requirements for the stopband PSD are compliant with clause 7.2.2.
 NOTE 5 – The integral of the PSD does not exceed 11.0 dBm in the 30 MHz frequency range.
 NOTE 6 – When SUPPORTEDCARRIERSds starts at 1 104 MHz, the Limit PSD mask below 1 104 MHz shall comply with Table F.4 of [ITU-T G.993.1].

Table C.10 – VTU-R Limit PSD mask (VDSL2 above TCM-ISDN band)

Band attribute	Frequency band f (MHz)	Limit PSD mask level (dBm/Hz) (Notes 1, 2 and 4)	Maximum power limitation in a 1-MHz sliding window (dBm) (Notes 1, 3 and 4)
US1	$0 < f < 0.12$	-120	
	$0.12 \leq f < 0.225$	-110	
	$0.225 \leq f < 3.575$	-100	
	$3.575 \leq f \leq 3.75$	$-80 + (20/0.175) \times (f - 3.75)$	
	$3.75 < f < 5.2$	$-60 + 3.5 (= -56.5)$	
	$5.2 \leq f \leq 5.375$	$-80 - (20/0.175) \times (f - 5.2)$	
	$5.375 < f < 8.325$	-100	-52
US2	$8.325 \leq f \leq 8.5$	$-80 + (20/0.175) \times (f - 8.5)$	
	$8.5 < f < 12$	$-60 + 3.5 (= -56.5)$	
	$12 \leq f \leq 12.175$	$-80 - (20/0.175) \times (f - 12)$	
	$12.175 < f < 17.925$	-100	-52
	$17.925 \leq f \leq 18.1$	$-80 + (20/0.175) \times (f - 18.1)$	

Table C.10 – VTU-R Limit PSD mask (VDSL2 above TCM-ISDN band)

Band attribute	Frequency band f (MHz)	Limit PSD mask level (dBm/Hz) (Notes 1, 2 and 4)	Maximum power limitation in a 1-MHz sliding window (dBm) (Notes 1, 3 and 4)
US3	$18.1 < f < 30$	$-60 + 3.5 (= -56.5)$	
	$30 \leq f \leq 30.175$	$-80 - (30/0.175) \times (f - 30)$	
	$30.175 < f$	-110	
NOTE 1 – All PSD and power measurements are into 100 Ω . NOTE 2 – The Limit PSD mask level shall be measured with a 10-kHz resolution bandwidth. NOTE 3 – The maximum power in a 1-MHz sliding window shall be measured with a 1-MHz resolution bandwidth. NOTE 4 – The requirements for the stopband PSD are compliant with clause 7.2.2. NOTE 5 – The integral of the PSD does not exceed 12.3 dBm in the 30 MHz frequency range.			

C.3 VDSL2 system with PSD reduction at frequencies below DPBOFMAX

The downstream transmit PSD masks for frequencies below DPBOFMAX shall not exceed RESULTMASKds(f) defined in clause 7.3.1.2.13 of [ITU-T G.997.1]. An example set of parameters intended to protect ADSL2plus is described in Appendix I. The upstream transmit PSD mask for frequencies below DPBOFMAX shall comply with Table C.3, Table C.4, Table C.7, Table C.8 or Table C.10. For frequencies between DPBOFMAX and 30 MHz, the downstream transmit PSD mask shall comply with Table C.5 or Table C.9 and the upstream transmit PSD mask shall comply with Table C.7 or Table C.10. Other PSD limitations, including US0 power reduction, are for further study.

C.4 Upstream power back-off (UPBO) PSD masks

The VTU-R shall calculate the required UPBO and its upstream PSD mask as specified in clause 7.2.1.3.2.

The UPBO reference PSD, UPBOPSD(f), is parameterized as $-a - b \sqrt{f}$ dBm/Hz, with f expressed in MHz.

For US1 and US2 as defined in Figure C.1, values of a and b are given in Table C.11. These values shall apply when the Limit PSD mask for US1 and US2 does not exceed -56.5 dBm/Hz.

When the Limit PSD mask for US1 and US2 is different from the one defined not to exceed -56.5 dBm/Hz, the values of a and b for UPBOPSD are for further study. For US3 defined not to exceed -56.5 dBm/Hz, the values of a and b for UPBOPSD are given in Table C.11.

Table C.11 – UPBOPSD parameters

		<i>a</i>	<i>b</i>
Limit PSD mask ≤ -56.5 dBm/Hz	US1	60	10.2
	US2	60	6.42
	US3	40 (Note)	0 (Note)
Other Limit PSD masks	US1	For further study	For further study
	US2		
	US3		

NOTE – ITU-T G.997.1 defines the set of parameter values $a = 40$ dBm/Hz, $b = 0$ dBm/Hz as a special configuration to disable UPBO in the respective upstream band.

C.5 Service Splitter

See F.2 of [ITU-T G.993.1].

For operation according to Annex C, the requirements applying over a frequency band up to 12 MHz in [ITU-T G.993.1] shall be met over a frequency band up to 30 MHz.

However, the return loss of the POTS splitter in the band between 12 MHz and 30 MHz shall be measured as shown in Figure C.2.

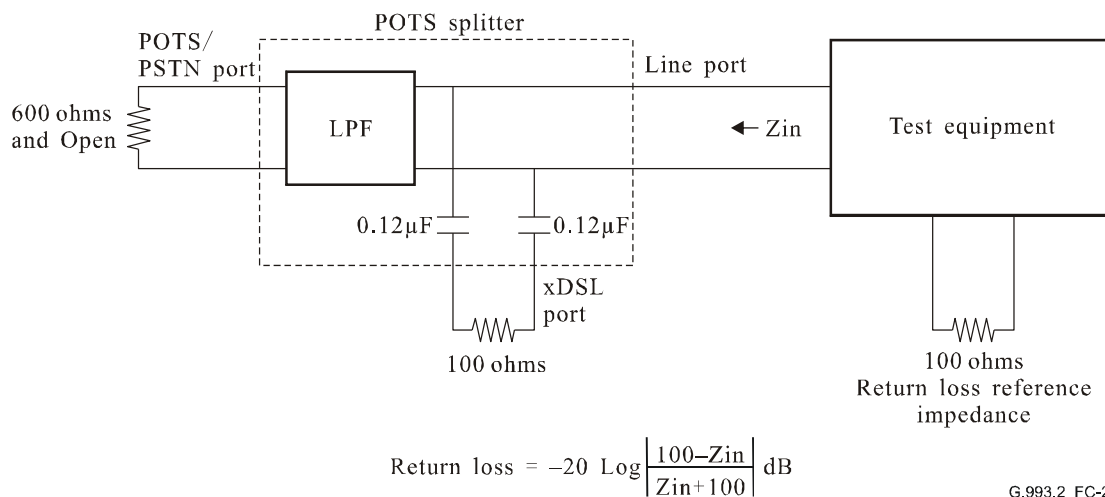

Figure C.2 – Impedance measurements in the band between 12 MHz and 30 MHz for the CO and remote POTS splitters

C.6 Test loops and crosstalk disturbers

C.6.1 Test loops

C.6.1.1 Loop configurations

For frequency bands below 12 MHz, see clause F.3.1.1 of [ITU-T G.993.1]. For VDSL2 using frequency bands above 12 MHz, the following settings for bridged tap parameter Y_2 shall be added to test loop VLOOP-J3 (see Figure F.10 of [ITU-T G.993.1]):

$Y_2 = 1\text{-}10$ m at every 1 m step.

C.6.1.2 Primary line constants

See F.3.1.2 of [ITU-T G.993.1].

The equations of primary line constants are applicable up to 30 MHz.

C.6.1.3 Line transfer function and test loop characteristics

See F.3.1.3 of [ITU-T G.993.1].

C.6.2 Crosstalk disturbers

C.6.2.1 Disturber types

See F.3.2.1 of [ITU-T G.993.1].

The five disturber types shown below using ITU-T G.992.1 (Annex I), VDSL2 self, and PNT3 (in [ITU-T G.9954]) shall be added:

- Noise $B_5 = 9$ VDSL2 self NEXT and FEXT (see Tables C.1 to C.10 for the disturber PSD);
- Noise $B_6 = 9$ ADSL NEXT and FEXT (see Figure I.13 of [ITU-T G.992.1] (I.4.8.1 of [ITU-T G.992.1]) for the disturber PSD);
- Noise $B_7 = 9$ PNT3 (mask #1) NEXT (see Table 6-10 of [ITU-T G.9954] (mask #1) in clause 6.8.3.1 of [ITU-T G.9954] for the disturber PSD);
- Noise $B_8 = 9$ PNT3 (mask #2) NEXT (see Table 6-12 of [ITU-T G.9954] (mask #2) in clause 6.8.3.1 of [ITU-T G.9954] for the disturber PSD); and
- Noise $B_9 = 9$ PNT3 (mask #3) NEXT (see Table 6-14 of [ITU-T G.9954] (mask #3) in clause 6.8.3.1 of [ITU-T G.9954] for the disturber PSD).

Other disturbers are for further study.

C.6.2.2 Power spectral density of disturbers

See F.3.2.2 of [ITU-T G.993.1].

For Annex I of [ITU-T G.992.1], see Figure I.13 of [ITU-T G.992.1] (I.4.8.1 of [ITU-T G.992.1]). The disturber has an offset of -3.5 dB with respect to the peak mask defined in Figure I.13 of [ITU-T G.992.1]. For VDSL2 self, see Tables C.1 to C.10. In the in-band regions, the disturber has an offset of -3.5 dB with respect to the peak mask defined in Tables C.1 to C.10. For PNT3 (ITU-T G.9954), see Table 6-10 of [ITU-T G.9954] (mask #1), Table 6-12 of [ITU-T G.9954] (mask #2) and Table 6-14 of [ITU-T G.9954] (mask #3) in clause 6.8.3.1 of [ITU-T G.9954].

C.6.2.3 Power spectral density of crosstalk

See clause F.3.2.3 of [ITU-T G.993.1].

Annex D

For further study.

Annex E

For further study.

Annex F

For further study.

Annex G

For further study.

Annex H

For further study.

Annex J

For further study.

Annex K

For further study.

Annex L

TPS-TC functional descriptions

(This annex forms an integral part of this Recommendation.)

This annex contains the functional descriptions of various TPS-TC types that may be used within the ITU-T G.993.2 transceivers.

L.1 STM transmission convergence (STM-TC) function

L.1.1 Scope

The STM-TC function provides procedures for the transport of one STM-TC stream in either the upstream or downstream direction. Octet boundaries and the position of most significant bits are explicitly maintained across the transport for the STM-TC stream. The STM-TC stream is presented synchronously across the γ_R or γ_O reference point with respect to the synchronization signals across the α/β interface.

Support for a plesiochronous interface is under study.

L.1.2 References

This clause is intentionally blank because there are no STM-TC specific references.

L.1.3 Definitions

This clause is intentionally blank because there are no STM-TC specific definitions.

L.1.4 Abbreviations

This clause is intentionally blank because there are no STM-TC specific abbreviations.

L.1.5 Transport capabilities

The STM-TC function provides procedures for the transport of one STM-TC stream in either the upstream and downstream direction. Octet boundaries and the position of most significant bits shall be explicitly maintained across the transport for the STM-TC stream. The STM-TC stream is presented synchronously across the γ_R or γ_O reference point with respect to the PMD bit clocks.

After each of the transmit STM-TC procedures has been applied, transport of the STM-TC stream to a receive STM-TC function at the other end of the link is carried out by underlying PMS-TC and PMD layers through a series of data frames and PMD symbols. The STM-TC transport capabilities are configured by control parameters described in clause L.1.7. The control parameters provide for the application of appropriate data rates and characteristics of the STM-TC stream. The values of all control parameters are set during initialization or reconfiguration of the VTU. The receive STM-TC function recovers the input signal that was presented to the corresponding transmit STM-TC function and which has been transported across the STM-TC, PMS-TC, and PMD functions of a VTU-O and VTU-R pair.

The transmit STM-TC function accepts input signals from the data plane and control plane within the VTU. As a data plane element, the transmit STM-TC function accepts one STM-TC stream from the γ_O or γ_R reference points. The stream is associated with one, and only one, STM-TC function. These input signals are conveyed to the receive STM-TC interface as shown in Figure L.1. Octet boundaries and the position of most significant bits are explicitly maintained across the transport for the STM-TC frame bearers.

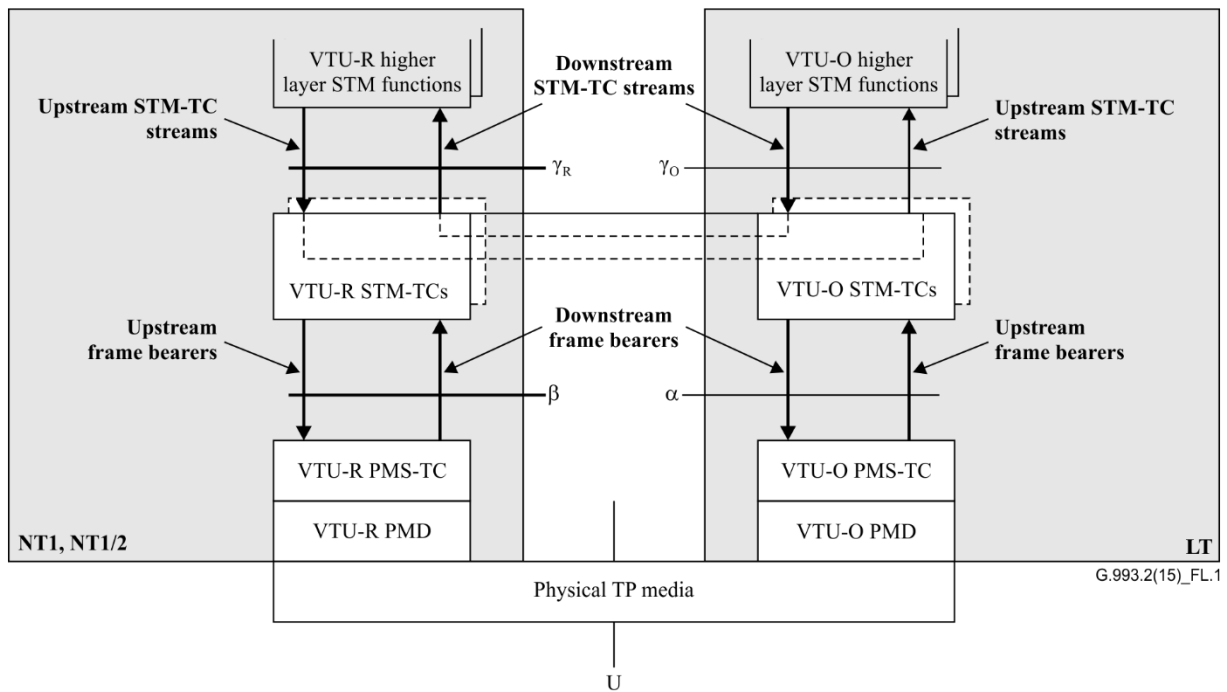

Figure L.1 – STM-TC transport capabilities within the user plane

As a management plane element, there are no specific transport functions provided by the STM-TC function. However, there are some specific indicator bits and overhead response definitions for the STM-TC function as defined in this annex.

L.1.6 Interface primitives

Each VTU-O STM-TC function has many interface signals as shown in Figure L.2. Each named signal is composed of one or more primitives, as denoted by the directional arrows. The primitive type associated with each arrow is according to the figure legend.

The diagram is divided by a dotted line to separate the downstream function and signals from the upstream. The signals shown at the top edge convey primitives to and from the higher layer STM function. The signals shown at the bottom edge convey primitives to and from the PMS-TC function.

Each VTU-R STM-TC function has similar interface signals as shown in Figure L.3. In this figure, the upstream and downstream labels are reversed from Figure L.1.

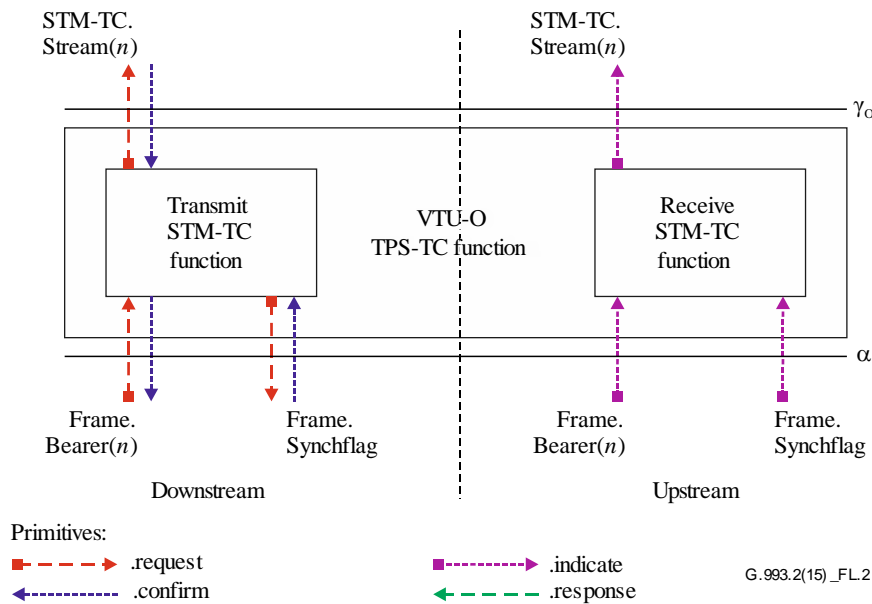

Figure L.2 – Signals of the VTU-O STM-TC function

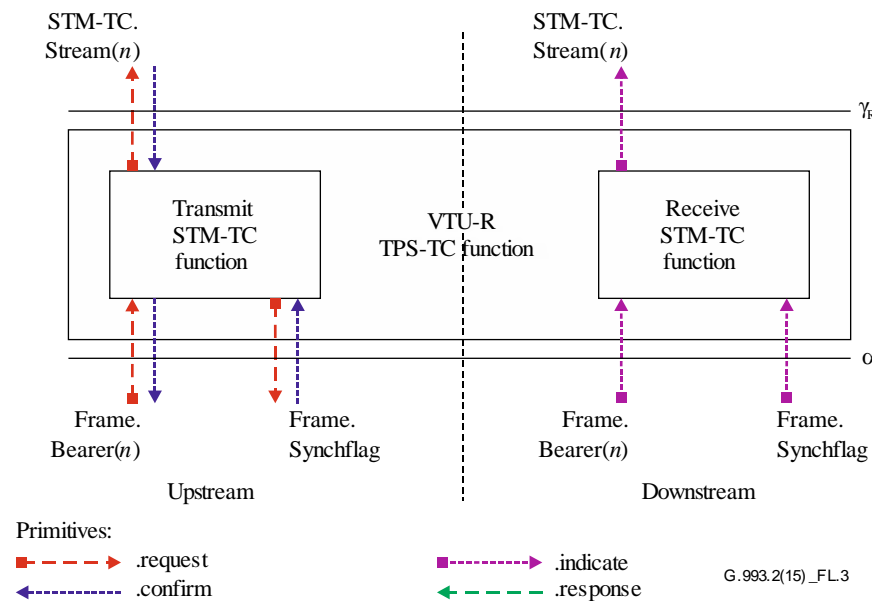

Figure L.3 – Signals of the VTU-R STM-TC function

The signals shown in Figures L.2 and L.3 are used to carry primitives between functions of this Recommendation. Primitives are only intended for purposes of clearly specifying functions to assure interoperability.

The primitives that are used between a higher layer STM function and STM-TC function are described in Table L.1. These primitives support the exchange of frame bearer data and regulation of data flow to match the PMS-TC configuration. They also support coordinated on-line reconfiguration of the VTU-O and VTU-R.

Table L.1 – Signalling primitives between STM higher layer functions and the STM-TC function

Signal	Primitive	Description
TPS-TC.Stream(<i>n</i>).STM	.request	This primitive is used by the transmit STM-TC function to request one or more octets from the transmit higher layer STM function to be transported. By the interworking of the request and confirm, the data flow is matched to the STM-TC configuration (and underlying functions). Primitives are labelled <i>n</i> , where <i>n</i> corresponds to the TPS-TC function id (e.g., <i>n</i> = 0 for TPS-TC #0).
	.confirm	The transmit higher layer STM function passes one or more octets to the STM-TC function to be transported with this primitive. Upon reception of this primitive, the STM-TC function shall perform the data plane procedures in clause L.1.8.
	.indicate	The receive STM-TC function passes one or more octets that have been transported with this primitive to the receive higher layer STM function.

L.1.7 Control parameters

The configuration of the STM-TC function is controlled by a set of control parameters defined in Table L.2 in addition to those specified in the main body of this Recommendation. The values of these control parameters shall be set and communicated during initialization or reconfiguration (if applicable) of a VTU pair. All the values are determined by application requirements and means that are beyond the scope of this Recommendation.

Table L.2 – STM-TC parameters

Parameter	Definition
Minimum net data rate <i>net_min_n</i>	The minimum net data rate supported by the STM-TC stream # <i>n</i> . The VTU shall implement appropriate initialization and reconfiguration procedures to provide <i>net_min_n</i> data rate.
Maximum net data rate <i>net_max_n</i>	The maximum net data rate supported by STM-TC stream # <i>n</i> . During initialization and reconfiguration procedures, the net data rate shall not exceed this value.
Minimum SOS net data rate <i>MIN-SOS-BR_n</i>	The minimum net data rate required by the STM-TC stream # <i>n</i> for a valid SOS request (see clause 13.4).
Minimum reserved data rate <i>net_reserve_n</i>	The minimum reserved data rate supported by STM-TC stream # <i>n</i> that shall always be available upon request by an appropriate reconfiguration procedure. The value of <i>net_reserve_n</i> shall be constrained such that $net_min_n \leq net_reserve_n \leq net_max_n$. This parameter is not used in this version of this Recommendation and shall be set to <i>net_min_n</i> . The OLR procedures that utilize this parameter will be defined in a future revision of this Recommendation.
Maximum PMS-TC latency <i>delay_max_n</i>	The STM-TC stream # <i>n</i> shall be transported with underlying PMS-TC functions configured such that the derived parameter <i>delay_p</i> is no larger than this control parameter <i>delay_max_n</i> .
Minimum PMS-TC impulse noise protection <i>INP_min_n</i>	The STM-TC stream # <i>n</i> shall be transported with underlying PMS-TC functions configured such that the derived parameter <i>INP_p</i> is not lower than this control parameter <i>INP_min_n</i> .

Table L.2 – STM-TC parameters

Parameter	Definition
Channel initialization policy $Clpolicy_n$	This parameter controls the policy to be applied in setting the transceiver configuration parameters during initialization (see clause 12.3.7).
Maximum delay variation DV_{max}_n	The STM-TC stream #n shall be transported with underlying PMS-TC OLR function as defined in clause 13.4 such that the derived parameter DV_p is not lower than this control parameter DV_{max}_n .

If the values of net_min_n , net_max_n , and $net_reserve_n$ (see Table 12-54) are set to the same value, then the STM-TC stream is designated as a fixed data rate STM-TC stream (i.e., RA-MODE = MANUAL, see Table 12-49). If $net_min_n = net_reserve_n$ and $net_min_n \neq net_max_n$, then the STM-TC stream is designated as a flexible data rate STM-TC stream. If the value of $net_min_n \neq net_max_n \neq net_reserve_{max}$, then the STM-TC stream is designated as a flexible data rate STM-TC stream with reserved data rate allocation.

During initialization and reconfiguration procedures (except SOS), the actual net data rate net_act_n for stream #n shall always be set to the value of the derived parameter NDR_{pn} of the underlying PMS-TC latency path function and shall be constrained such that $net_min_n \leq net_act_n \leq net_max_n$. However, in case the $net_min_n = net_max_n$, the net_act_n may exceed the net_max_n by up to 8 kbit/s, to allow for the PMS-TC net data rate granularity (see Table 5-1). If $net_min_n < net_max_n$, the net_max_n shall be set at least 8 kbit/s above the net_min_n , to allow for the PMS-TC net data rate granularity to meet the $net_min_n \leq net_act_n \leq net_max_n$ requirement. The actual latency for the stream #n, $delay_act_n$ shall always be set to the value of the derived parameter $delay_p$ of the underlying PMS-TC latency path function and constrained such that $delay_act_n \leq delay_max_n$.

The actual impulse noise protection, INP_act_n , of transport of stream #n shall always be set to the value of the derived parameter INP_p of the underlying PMS-TC path function and constrained such that $INP_act_n \geq INP_min_n$. The values net_act_n , $delay_act_n$ and INP_act_n are not control parameters; these values are the result of specific initialization and reconfiguration procedures.

During SOS reconfiguration procedures, the net data rates, INP and delay shall comply with clause 13.4.

L.1.7.1 Valid configurations

The configurations listed in Table L.3 are valid for the STM-TC function.

Table L.3 – Valid configuration for STM-TC function

Parameter	Capability
$type_n$	1
net_min_n	net_min_n may be supported for all valid framing configurations.
net_max_n	net_max_n may be supported for all valid framing configurations.
$net_reserve_n$	$net_reserve_n$ may be supported for all valid framing configurations.
$MIN-SOS-BR_n$	$MIN-SOS-BR_n$ may be supported for all valid framing configurations.
$delay_max_n$	All valid values of $delay_max_n$ (see Table 12-51).
INP_min_n	All valid values of INP_min_n (Table 12-51).
$Clpolicy_n$	0, 1, 2

L.1.7.2 Mandatory configurations

If implementing a STM-TC, a VTU shall support all combinations of the values of STM-TC control parameters for a STM-TC function displayed in Tables L.4 and L.5 in the downstream and upstream directions, respectively. The transmitter and receiver shall support mandatory features displayed in these tables, and in Table L.6.

Table L.4 – Mandatory downstream configuration for STM-TC function

Parameter	Capability
<i>type_n</i>	1
<i>delay_max_n</i>	All valid values shall be supported.
<i>INP_min_n</i>	All valid values shall be supported.
<i>CIpolicy_n</i>	0

Table L.5 – Mandatory upstream configuration for STM-TC function

Parameter	Capability
<i>type_n</i>	1
<i>delay_max_n</i>	All valid values shall be supported.
<i>INP_min_n</i>	All valid values shall be supported.
<i>CIpolicy</i>	0

Table L.6 – Mandatory bidirectional configuration for STM-TC function

Parameter	Capability
<i>bi_net_min</i>	<i>bi_net_min</i> shall be supported for all valid framing configurations up to and equal to the MBDC defined in clause 6.2.7 for the applicable profile.
<i>bi_net_max</i>	<i>bi_net_max</i> shall be supported for all valid framing configurations up to and equal to the MBDC defined in clause 6.2.7 for the applicable profile.
<i>bi_net_reserve</i>	<i>bi_net_reserve</i> shall be supported for all valid framing configurations up to and equal to the MBDC defined in clause 6.2.7 for the applicable profile.

L.1.8 Data plane procedures

Upon reception of the Frame.Bearer.request(*n*) primitive, the transmit STM-TC function shall signal a TPS-TC.Stream.STM.request to the STM higher layer function, requesting data for transport.

Upon reception of a TPS-TC.STM.confirm(*n*) primitive, the receive STM-TC function #*n* shall signal a Frame.Bearer(*n*).confirm primitive to the PMS-TC function, providing data for transport.

Upon reception of the Frame.Bearer.indicate(*n*) primitive, the receive STM-TC function #*n* shall signal a TPS-TC.Stream.STM.indicate to the STM higher layer function, providing data that has been transported.

L.1.9 Management plane procedures

L.1.9.1 Surveillance primitives

Surveillance primitives for the STM-TC function are under study.

L.1.9.2 Indicator bits

The indicator bits for TPS-TC #*n* and bearer channel #*n* (*n* = 0 or 1) are defined in clause 9.5.2.2. The TIB#*n*-0, TIB#*n*-1, TIB#*n*-2 and TIB#*n*-3 shall be set to a 1 for use in Table 9-5.

L.1.9.3 Overhead command formats

L.1.9.3.1 Inventory command

For further study.

L.1.9.3.2 Control value read command

For further study.

L.1.9.3.3 Management Counter Read command

The TPS-TC octets in the response to the overhead Management Counter Read command corresponding to the STM-TC function are under study. The block of counter values corresponding to the STM-TC function returned in the message described in Table 11-18 shall have zero length.

L.1.10 Initialization procedure

The STM-TC shall be configured during initialization as follows:

- During the Channel Analysis and Exchange phase (see clause 12.3.5.2.1), the VTU-O uses the O-MSG 1 SOC message (see Table 12-49) to convey its upstream and downstream TPS-TC capabilities and bearer control parameters (see Table L.2) to the VTU-R.
- During the Channel Analysis and Exchange phase (see clause 12.3.5.2.1), the VTU-R uses the R-MSG 2 SOC message (see Table 12-60) to convey its upstream and downstream TPS-TC capabilities and bearer control parameters (see Table L.2) to the VTU-O.
- During the Channel Analysis and Exchange phase (see clause 12.3.5.2.1.2), the VTU-O uses the O-TPS SOC message (see Table 12-53) to convey the upstream and downstream TPS-TC configuration to the VTU-R. It is based on the capabilities that were indicated in O-MSG 1 and R-MSG 2.

L.1.11 On-line reconfiguration

The on-line reconfiguration of the STM-TC is outside the scope of this Recommendation. There is no specified mechanism to modify the value of the control parameters of the STM-TC function. The values of *net_act* and *delay_act* are automatically updated from the underlying PMS-TC latency path function.

L.1.11.1 Changes to an existing stream

Update of the *net_act* and *delay_act* parameters of an existing STM-TC function shall only occur at octet boundaries. The transmit STM-TC function uses the new values of the *net_act*, and *delay_act* to generate octets that follow the signalling of the Frame.Synchflag.confirm primitive. The receive STM-TC function procedures process octets that follow the signalling of the Frame.Synchflag.indicate primitive using the new values of these parameters.

L.2 ATM transmission convergence (ATM-TC) function

L.2.1 Scope

The ATM-TC function provides procedures for the transport of one ATM-TC stream in either the upstream or downstream direction. Octet boundaries and the position of most significant bits are explicitly maintained across the transport for the ATM-TC stream. The ATM-TC stream is presented asynchronously across the γ_R or γ_O reference point with respect to the synchronization signals across the α/β interface.

L.2.2 References

References applicable to this annex are included in clause 2.

L.2.3 Definitions

This clause is intentionally blank because there are no ATM-TC specific definitions.

L.2.4 Abbreviations

Abbreviations applicable to this annex are included in clause 4.

L.2.5 Transport capabilities

The ATM-TC function provides procedures for the transport of one ATM-TC stream in either the upstream or downstream direction. Octet boundaries and the position of most significant bits shall be explicitly maintained across the transport for the ATM-TC stream. The ATM-TC stream is presented asynchronously across the γ_R or γ_O reference point with respect to the PMD bit clocks.

After each of the transmit ATM-TC procedures has been applied, transport of the ATM-TC stream to a receive ATM-TC function at the other end of the link is carried out by underlying PMS-TC and PMD layers through a series of data frames and PMD symbols. The ATM-TC transport capabilities are configured by control parameters described in clause L.2.7. The control parameters provide for the application appropriate data rates and characteristics of the ATM-TC stream. The values of all control parameters are set during initialization or reconfiguration of the VTU. The receive ATM-TC function recovers the input signal that was presented to the corresponding transmit ATM-TC function and which has been transported across the ATM-TC, PMS-TC and PMD functions of an VTU-O and VTU-R pair.

The transmit ATM-TC function accepts input signals from the data plane and control plane within the VTU. As a data plane element, the transmit ATM-TC function accepts one ATM-TC stream from the γ_O or γ_R reference points. The stream is associated with one, and only one, ATM-TC function. These input signals are conveyed to the receive ATM-TC interface as shown in Figure L.4. Octet boundaries and the position of most significant bits are explicitly maintained across the transport for the ATM-TC frame bearers.

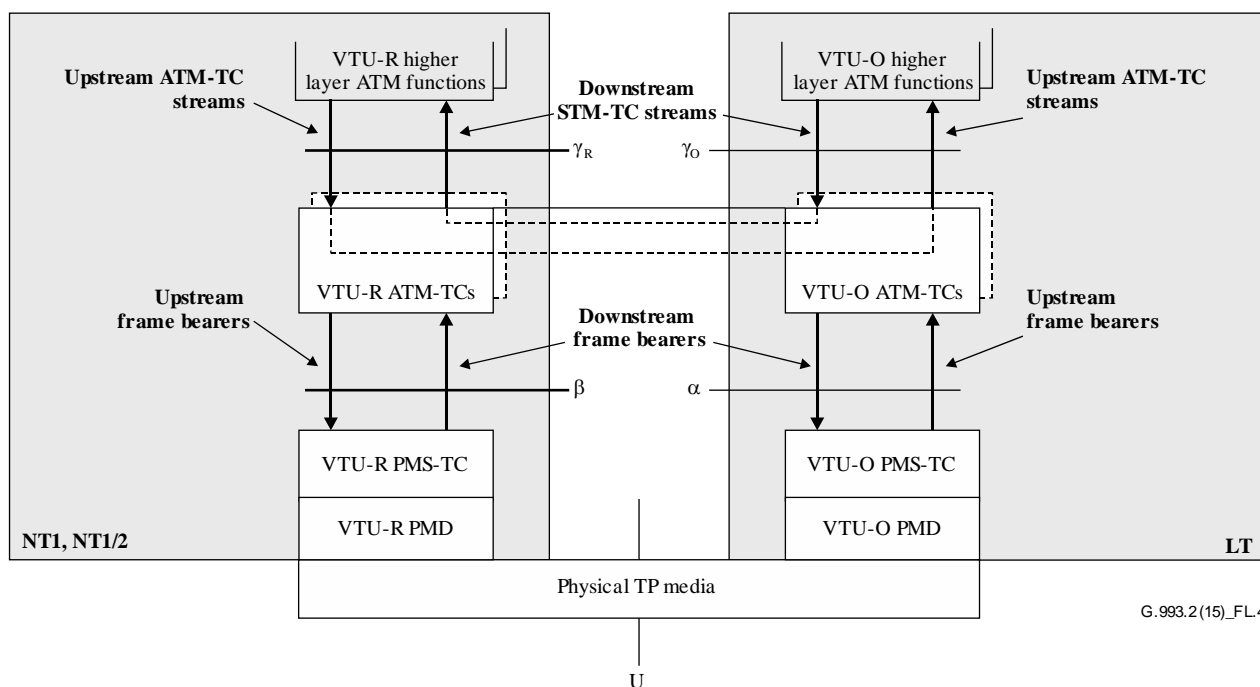

Figure L.4 – ATM-TC transport capabilities within the user plane

As a management plane element, there are no specific transport functions provided by the ATM-TC function. However, there are some specific indicator bit and overhead response definitions for the ATM-TC function as defined in this annex.

L.2.5.1 Additional functions

In addition to transport functions, the transmit ATM-TC function also provides procedures for rate decoupling of the ATM-TC stream and the frame bearer by ATM idle cell insertion, ATM header error control generation, and scrambling, as described in clause L.2.8.

The receive ATM-TC function reverses each of the listed procedures so that the transported information may be recovered. Additionally, the VTU receive framing function provides several supervisory indications and defect signals associated with some of these procedures (e.g., ATM cell delineation status, HEC error check failure).

L.2.6 Interface primitives

Each VTU-O ATM-TC function has many interface signals as shown in Figure L.5. Each named signal is composed of one or more primitives, as denoted by the directional arrows. The primitive type associated with each arrow is according to the figure legend.

The diagram is divided by a dotted line to separate the downstream function and signals from the upstream. The signals shown at the top edge convey primitives to and from the higher layer ATM function. The signals shown at the bottom edge convey primitives to and from the PMS-TC function.

Each VTU-R ATM-TC function has similar interface signals as shown in Figure L.6. In this figure, the upstream and downstream labels are reversed from Figure L.5.

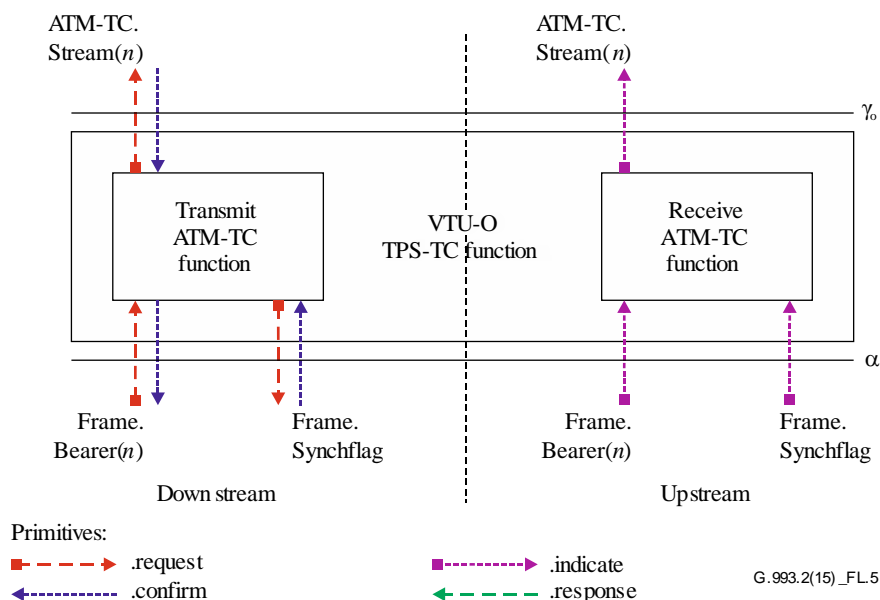

Figure L.5 – Signals of the VTU-O ATM-TC function

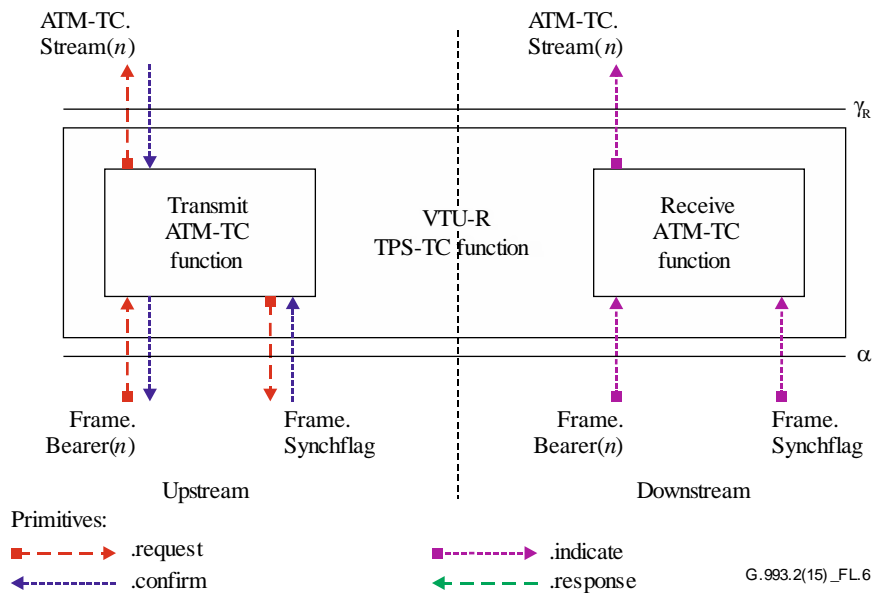

Figure L.6 – Signals of the VTU-R ATM-TC function

The signals shown in Figures L.5 and L.6 are used to carry primitives between functions of this Recommendation. Primitives are only intended for purposes of clearly specifying functions to assure interoperability.

The primitives that are used between a higher layer ATM function and ATM-TC function are described in Table L.7. These primitives support the exchange of stream and frame bearer data and regulation of data flow to match the PMS-TC configuration. They also support coordinated on-line reconfiguration of the VTU-O and VTU-R.

Table L.7 – Signalling primitives between ATM higher layer functions and the ATM-TC function

Signal	Primitive	Description
TPS-TC.Stream(<i>n</i>). ATM	.request	This primitive is used by the transmit ATM-TC function to request one or more ATM cells from the transmit higher layer ATM function to be transported. By the interworking of the request and confirm, the data flow is matched to the ATM-TC configuration (and underlying functions). Primitives are labelled <i>n</i> , where <i>n</i> corresponds to the TPS-TC function id (e.g., <i>n</i> = 0 for TPS-TC #0).
	.confirm	The transmit higher layer ATM function passes one or more ATM cells to the ATM-TC function to be transported with this primitive. Upon reception of this primitive, the ATM-TC function shall perform the procedures in L.2.8.2.
	.indicate	The receive ATM-TC function passes one or more ATM cells to the receive higher layer ATM function that have been transported with this primitive.

L.2.7 Control parameters

The configuration of the ATM-TC function is controlled by a set of control parameters defined in Table L.8 in addition to those specified in the main body of this Recommendation. The values of these control parameters shall be set and communicated during initialization or reconfiguration (if applicable) of a VTU pair. All the values are determined by application requirements and means that are beyond the scope of this Recommendation.

Table L.8 – ATM-TC parameters

Parameter	Definition
Minimum net data rate <i>net_min_n</i>	The minimum net data rate supported by the ATM-TC stream # <i>n</i> . The VTU shall implement appropriate initialization and reconfiguration procedures to provide <i>net_min_n</i> data rate.
Maximum net data rate <i>net_max_n</i>	The maximum net data rate supported by ATM-TC stream # <i>n</i> . During activation and reconfiguration procedures, the net data rate shall not exceed this value.
Minimum SOS net data rate <i>MIN-SOS-BR_n</i>	The minimum net data rate required by the ATM-TC stream # <i>n</i> for a valid SOS request (see clause 13.4).
Minimum reserved data rate <i>net_reserve_n</i>	The minimum reserved data rate supported by ATM-TC stream # <i>n</i> that shall always be available upon request by an appropriate reconfiguration procedure. The value of <i>net_reserve_n</i> shall be constrained such that $net_min_n \leq net_reserve_n \leq net_max_n$. This parameter is not used in this version of this Recommendation and shall be set to <i>net_min_n</i> . The OLR procedures that utilize this parameter will be defined in a future revision of this Recommendation.
Maximum PMS-TC latency <i>delay_max_n</i>	The ATM-TC stream # <i>n</i> shall be transported with underlying PMS-TC functions configured such that the derived parameter <i>delay_p</i> is no larger than this control parameter <i>delay_max_n</i> .
Minimum PMS-TC impulse noise protection <i>INP_min_n</i>	The ATM-TC stream # <i>n</i> shall be transported with underlying PMS-TC functions configured such that the derived parameter <i>INP_p</i> is not lower than this control parameter <i>INP_min_n</i> .
Channel initialization policy <i>CIpolicy_n</i>	This parameter controls the policy to be applied in setting the transceiver configuration parameters during initialization (see clause 12.3.7).
Maximum delay variation <i>DV_max_n</i>	The ATM-TC stream # <i>n</i> shall be transported with underlying PMS-TC OLR function as defined in clause 13.4 such that the derived parameter <i>DV_p</i> is not lower than this control parameter <i>DV_max_n</i> .

If the values of *net_min_n*, *net_max_n*, and *net_reserve_n* (see Table 12-54) are set to the same value, then the ATM-TC stream is designated as a fixed data rate ATM-TC stream (i.e., RA-MODE = MANUAL, see Table 12-49). If $net_min_n = net_reserve_n$ and $net_min_n \neq net_max_n$, then the ATM-TC stream is designated as a flexible data rate ATM-TC stream. If the value of $net_min_n \neq net_max_n \neq net_reserve_n$, then the ATM-TC stream is designated as a flexible data rate ATM-TC stream with reserved data rate allocation.

During initialization and reconfiguration procedures (except SOS), the actual net data rate *net_act_n* for stream #*n* shall always be set to the value of the derived parameter *NDR_{pn}* of the underlying PMS-TC latency path function and shall be constrained such that $net_min_n \leq net_act_n \leq net_max_n$. However, in case the $net_min_n = net_max_n$, the *net_act_n* may exceed the *net_max_n* by up to 8 kbit/s, to allow for the PMS-TC net data rate granularity (see Table 5-1). If $net_min_n < net_max_n$, the *net_max_n* shall be set at least 8 kbit/s above the *net_min_n*, to allow for the PMS-TC net data rate granularity to meet the $net_min_n \leq net_act_n \leq net_max_n$ requirement. The actual latency *delay_act_n* of transport of stream #*n* shall always be set to the value of the derived parameter *delay_p* of the underlying PMS-TC path function and constrained such that $delay_min_n \leq delay_act_n \leq delay_max_n$. The values *net_act_n* and *delay_act_n* are not control parameters; these values are the result of specific initialization and reconfiguration procedures.

If ATM bonding is not set in the ITU-T G.994.1 bonding code tree, $delay_min_n$ shall be set to ZERO both upstream and downstream, and $delay_max_n$ can be set to any valid value. If ATM bonding is set, then the ITU-T G.994.1 bonding code tree includes the value of the $max_delay_variation$ control parameter for downstream ATM bonding and the $delay_min_n$ shall be set to $delay_max_n - max_delay_variation$ for the downstream direction. If information related to $delay_min_n$ is available through the VTU-R bonding management interface over the γ_R reference point, it may take precedence over the value derived from the ITU-T G.994.1 bonding code tree. For the upstream direction, the information related to $delay_min_n$ is available through the VTU-O bonding management interface over the γ_O reference point. For both upstream and downstream, if $delay_min_n$ is greater than 0, there are combinations of $delay_min_n$ and $delay_max_n$ that may result in a failure to connect.

The actual impulse noise protection of the stream # n , INP_act_n of transport of stream # n , shall always be set to the value of the derived parameter INP_p of the underlying PMS-TC path function and constrained such that $INP_act_n \geq INP_min_n$. The values net_act_n , $delay_act_n$ and INP_act_n are not control parameters; these values are the result of specific initialization and reconfiguration procedures.

During SOS reconfiguration procedures, the net data rates, INP and delay shall comply with clause 13.4.

L.2.7.1 Valid configurations

The configurations listed in Table L.9 are valid for the ATM-TC function.

Table L.9 – Valid configuration for ATM-TC function

Parameter	Capability
$type_n$	2
net_min_n	net_min_n may be supported for all valid framing configurations.
net_max_n	net_max_n may be supported for all valid framing configurations.
$net_reserve_n$	$net_reserve_n$ may be supported for all valid framing configurations.
$MIN-SOS-BR_n$	$MIN-SOS-BR_n$ may be supported for all valid framing configurations.
$delay_max_n$	All valid values of $delay_max_n$ (see Table 12-51).
INP_min_n	All valid values of INP_min_n (see Table 12-51).
$CIpolicy_n$	0, 1, 2

L.2.7.2 Mandatory configurations

If implementing an ATM-TC, a VTU shall support all combinations of the values of ATM-TC control parameters for ATM-TC function #0 displayed in Tables L.10 and L.11 in the downstream and upstream directions, respectively. The transmitter and receiver shall support mandatory features displayed in these tables, and in Table L.12.

Table L.10 – Mandatory downstream configuration for ATM-TC function #0

Parameter	Capability
$type_n$	2
$delay_max_n$	All valid values shall be supported.
INP_min_n	All valid values shall be supported.
$CIpolicy_n$	0

Table L.11 – Mandatory upstream configuration for ATM-TC function #0

Parameter	Capability
$type_n$	2
$delay_max_n$	All valid values shall be supported.
INP_min_n	All valid values shall be supported.

Table L.12 – Mandatory bidirectional configuration for ATM-TC function

Parameter	Capability
bi_net_min	bi_net_min shall be supported for all valid framing configurations up to and equal to the MBDC defined in clause 6.2.7 for the applicable profile.
bi_net_max	bi_net_max shall be supported for all valid framing configurations up to and equal to the MBDC defined in clause 6.2.7 for the applicable profile.
$bi_net_reserve$	$bi_net_reserve$ shall be supported for all valid framing configurations up to and equal to the MBDC defined in clause 6.2.7 for the applicable profile.

L.2.8 Data plane procedures

L.2.8.1 Block diagram

Figure L.7 shows the functions within a transmit ATM-TC function that supports one unidirectional ATM-TC stream and one frame bearer. The incoming ATM-TC stream is shown at the leftmost edge of Figure L.7. The output signal from the ATM-TC function forms a frame bearer (i.e., input to the transmit PMS-TC function), and is shown at the rightmost edge of Figure L.7.

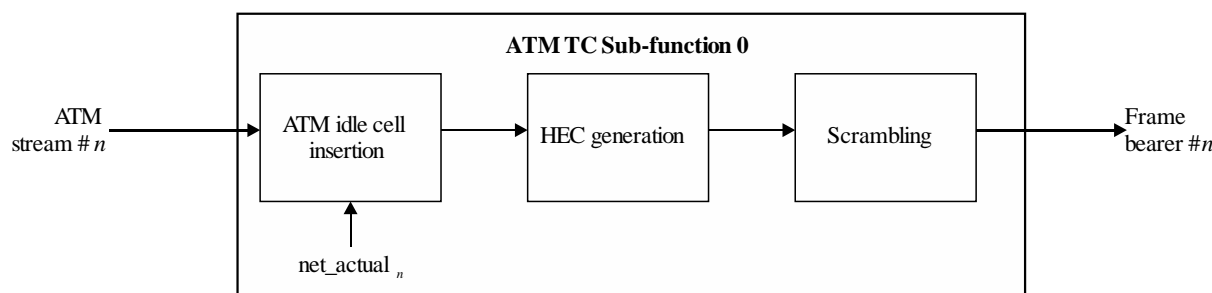

G.993.2(15)_FL.7

Figure L.7 – Block diagram of transmit ATM-TC function

In the ATM-TC stream and within the ATM-TC function, data octets shall be transmitted MSB first in accordance with [ITU-T I.361] and [ITU-T I.432.1]. All serial procedures within the ATM-TC function shall begin MSB first. Below the α and β interfaces of the VTU (starting with the Frame.Bearer primitives), data octets shall be transported LSB first. As a result, the MSB of the first octet of the first ATM-TC.Stream(n).confirm primitive will be the LSB of the first octet of the first Frame.Bearer(n).confirm primitive. The labelling of bits within the ATM-TC layer and at the frame bearer is shown in Figure L.8.

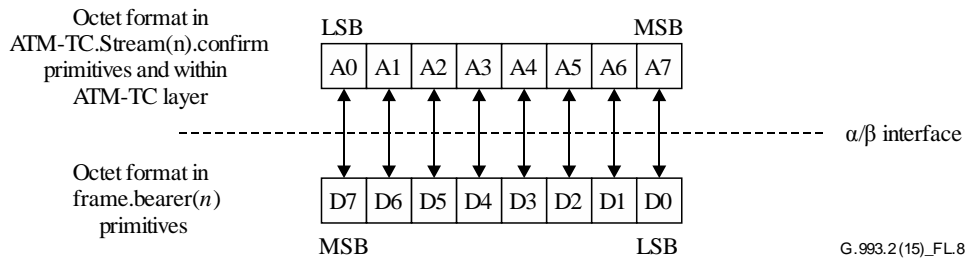

Figure L.8 – Bit mapping of the user plane transport function of the ATM-TC function

L.2.8.2 Rate matching by idle cell insertion

ATM idle cells shall be inserted by the transmit function to provide ATM cell rate decoupling. ATM idle cells shall not be delivered to higher layer functions by the receive ATM-TC functions.

ATM idle cells are identified by the standardized pattern for the cell header given in [ITU-T I.432.1].

L.2.8.3 HEC octet

The transmit ATM-TC function shall generate an HEC octet as described in [ITU-T I.432.1], including the recommended modulo 2 addition (XOR) of the binary pattern 01010101 to the HEC bits.

The HEC covers the entire cell header. The generator polynomial coefficient set used and the HEC sequence generation procedure shall be in accordance with [ITU-T I.432.1].

L.2.8.4 Cell delineation

The receiver ATM-TC function shall perform cell delineation. The cell delineation procedure permits the identification of ATM cell boundaries in the Frame.Bearer.indicate primitives. The procedure uses the HEC field in the cell header. Cell delineation shall be performed using a coding law by checking the HEC field in the cell header according to the algorithm described in [ITU-T I.432.1]. The cell delineation procedure is shown as a state machine in Figure L.9. Each state is described in Table L.13.

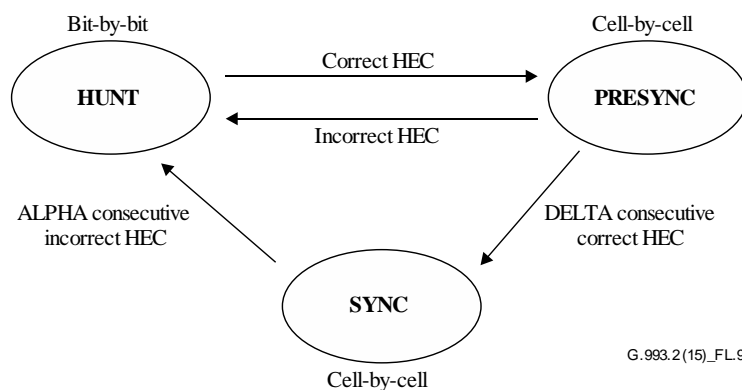

Figure L.9 – Cell delineation procedure state machine

Table L.13 – ATM cell delineation procedure states

State	Definition
HUNT	In the HUNT state, the cell delineation procedure may either be performed by checking bit-by-bit or octet-by-octet for the correct HEC. Once such an agreement is found, it is assumed that one header has been found, and the procedure enters the PRESYNC state. When octet boundaries are available, the cell delineation procedure may be performed octet-by-octet.
PRESYNC	In the PRESYNC state, the cell delineation procedure shall be performed by checking cell-by-cell for the correct HEC. If the correct HEC has been confirmed DELTA times consecutively, the procedure enters the SYNC state. If an incorrect HEC is found, the procedure returns to the HUNT state.
SYNC	In the SYNC state the cell delineation procedure shall return to the HUNT state if an incorrect HEC is obtained ALPHA times consecutively.

Specific values of ALPHA and DELTA are vendor discretionary, because the choice of these values is not considered to affect interoperability.

NOTE – The use of the values suggested in [ITU-T I.432.1] (ALPHA = 7, DELTA = 6) may be inappropriate due to the VTU transport characteristics.

L.2.8.5 ATM cell error detection

The receiver ATM-TC function shall implement error detection over the entire cell header as defined in [ITU-T I.432.1]. The code specified in [ITU-T I.432.1] is capable of single bit error correction and multiple bit error detection. However, HEC error correction shall not be implemented by the VTU, and any HEC error shall be considered as a multiple bit error.

ATM cells detected to be in error shall not be passed in a TPS-TC.Stream(*n*).ATM.indicate primitive.

L.2.8.6 Scrambler

The transmit ATM-TC function shall scramble the cell payload field to improve the security and robustness of the cell delineation mechanism. The self-synchronizing scrambler uses the polynomial $X^{43} + 1$. The scrambler procedures defined in [ITU-T I.432.1] shall be implemented.

L.2.9 Management plane procedures

L.2.9.1 Surveillance primitives

The ATM-TC function surveillance primitives are ATM path related. Both anomalies and defects are defined for each receiver ATM-TC function.

Three near-end anomalies are defined as follows:

- No Cell Delineation (*ncd-n*) anomaly: An *ncd-n* anomaly occurs immediately after receiving the first Frame.Bearer(*n*).indicate primitive. The anomaly terminates when the cell delineation process of the receive ATM-TC function #*n* transitions to the SYNC state. Once cell delineation is acquired, subsequent losses of cell delineation shall be considered as *ocd-n* anomalies.
- Out of Cell Delineation (*ocd-n*) anomaly: An *ocd-n* anomaly occurs when the cell delineation process of receive ATM-TC subfunction #*n* transitions from the SYNC state to the HUNT state. An *ocd-n* anomaly terminates when the cell delineation process transitions from PRESYNC state to SYNC state or when the *lcd-n* is asserted.
- Header Error Check (*hec-n*) anomaly: A *hec-n* anomaly occurs each time the ATM cell header process of receiver ATM-TC function #*n* detects an error.

These near-end anomalies are counted locally per [ITU-T G.997.1]. The values of the counter may be read or reset via local commands not defined in this Recommendation.

Three far-end anomalies are defined as follows:

- Far-end No Cell Delineation (*fncd-n*) anomaly: An *fncd-n* anomaly is an *ncd-n* anomaly detected at the far end.
- Far-end Out of Cell Delineation (*focd-n*) anomaly: An *focd-n* anomaly is an *ocd-n* anomaly detected at the far end.
- Far-end Header Error Check (*fhec-n*) anomaly: An *fhec-n* anomaly is a *hec-n* anomaly detected at the far end.

These far-end anomalies are not individually observable. The count of these far-end anomalies may be read and reset via overhead commands defined in clause 11.2.3.7. The format of the counters shall be as described in clause L.2.9.3.3.

One near-end defect is defined as follows:

- Loss of cell delineation (*lcd-n*): This defect occurs when at least one *ocd-n* anomaly is present in each of four consecutive overhead frames and no *sef-n* is present. An *lcd-n* terminates when no *ocd-n* anomaly is present in four consecutive overhead frames.

This near-end defect is processed locally per [ITU-T G.997.1].

One far-end defect is defined as follows:

- Far-end loss of cell delineation (*flcd-n*): This defect is an *lcd-n* detected at the far end.

This far-end defect is directly observed through an indicator bit as described in clause L.2.9.2.

L.2.9.2 Indicator bits

The indicator bits for TPS-TC #*n* and bearer channel #*n* (*n* = 0 or 1) are defined in clause 9.5.2.2.

The (logical OR of the) near-end defect *lcd-n* and the near-end anomalies *ncd-n* and *ocd-n* shall be mapped to the TPS-TC indicator TIB#*n*-0 and transported as described in Table 9-5. The bit shall be encoded as a 1 when inactive for use in Table 9-5.

The TIB#*n*-1, TIB#*n*-2 and TIB#*n*-3 shall be set to a 1 for use in Table 9-5.

NOTE – The TIB#*n*-0 corresponds to the NCD indicator bit defined in [ITU-T G.992.1].

L.2.9.3 Overhead command formats

L.2.9.3.1 Inventory command

For further study.

L.2.9.3.2 Control Value Read command

For further study.

L.2.9.3.3 Management Counter Read command

The TPS-TC management counters in the response to the overhead Management Counter Read command corresponding to the ATM-TC function shall be provided as defined in [ITU-T G.997.1]. The block of counter values corresponding to the ATM-TC function returned in the message described in Table 11-17 shall be as described in Table L.14.

Table L.14 – ATM-TC VTU management counter values

Length (Octets)	Octet number	Content
4	1 to 4	Counter of the HEC anomalies
4	5 to 8	Counter of total cells passed through HEC function
4	9 to 12	Counter of total cells passed to the upper layer ATM function
4	13 to 16	Counter of total bit errors detected in ATM idle cells payload

L.2.10 Initialization procedure

The ATM-TC shall be configured during initialization using the same procedure described in clause L.1.10.

L.2.11 On-line reconfiguration

The on-line reconfiguration of the ATM-TC is outside the scope of this Recommendation. There is no specified mechanism to modify the value of the control parameters of the ATM-TC function. The value of *net_act* and *delay_act* are automatically updated from the underlying PMS-TC latency path function.

L.2.11.1 Changes to an existing stream

Update of the *net_act* and *delay_act* parameters of an existing ATM-TC function shall only occur at octet boundaries. The transmit ATM-TC function uses the new values of the *net_act*, and *delay_act* to generate octets that follow the signalling of the Frame.Synchflag.confirm primitive. The receive ATM-TC function procedures process octets that follow the signalling of the Frame.Synchflag.indicate primitive using the new values of these parameters.

L.3 Packet transmission convergence function (PTM-TC)**L.3.1 Scope**

The PTM-TC is intended for Ethernet transport and generic packet transport. The PTM-TC function provides procedures for the transport of one PTM-TC stream in either the upstream or downstream direction. Packet boundaries, octet boundaries, and the position of most significant bits are explicitly maintained across the transport for the PTM-TC stream. The PTM-TC stream is presented asynchronously across the γ_R or γ_O reference point with respect to the synchronization signals across the α/β interface.

The reference model, functionality, and γ interface of the PMS-TC are defined in Annex N of [ITU-T G.992.3]. Referring to the reference model of Annex N of [ITU-T G.992.3], the PTM-TC function of VDSL2 could be established over either of the enabled bearer channels.

L.3.2 References

References applicable to this annex are included in clause 2.

L.3.3 Definitions

This clause is intentionally blank because there are no PTM-TC specific definitions.

L.3.4 Abbreviations

Abbreviations applicable to this annex are included in clause 4.

L.3.5 Transport capabilities

The net data rate for each PTM-TC function, both upstream and downstream, may be set independently of each other, and to any eligible value that is less than or equal to the assigned maximum net data rate in the corresponding direction. The maximum net data rate for each PTM-TC function, both upstream and downstream, is set during the system configuration.

A PTM-TC function may be mapped to either enabled bearer channel, which in turn may or may not be interleaved.

The PTM-TC shall provide full transparent data transfer between γ_O and γ_R interfaces (except non-correctable errors in the PMD sublayer due to the noise in the loop). The PTM-TC shall provide packet integrity over the bearer channel that it is mapped to.

The PTM-TC transport capabilities are configured by control parameters described in clause L.3.7. The control parameters provide for the application appropriate data rates and characteristics of the PTM-TC stream. The values of all control parameters are set during initialization or reconfiguration of the VTU.

The transmit PTM-TC function accepts input signals from the data plane within the VTU. As a data plane element, the transmit PTM-TC function accepts one PTM-TC stream from a PTM entity across the γ_O or γ_R reference point. The stream is associated with one and only one PTM-TC function. (See Figure L.10.)

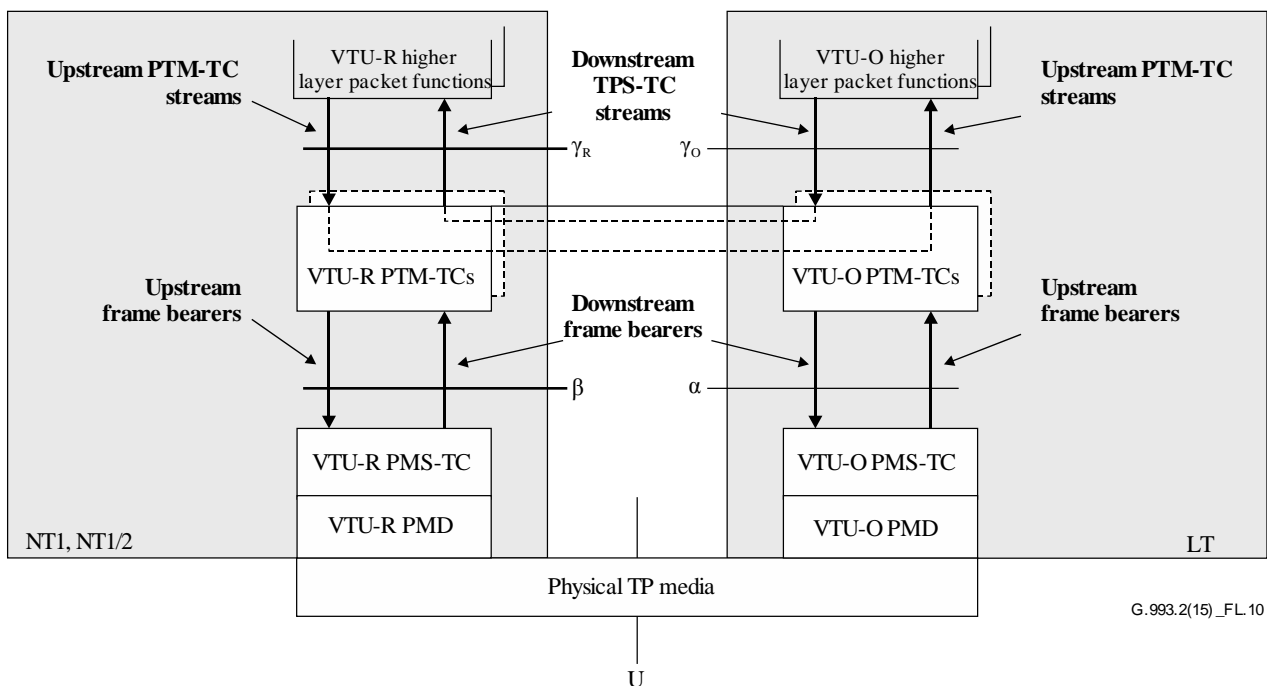

Figure L.10 – PTM-TC transport capabilities within the user plane

L.3.6 Interface primitives

The interface signals between the PTM-TC and PMS-TC (γ interface) are described in Annex N of [ITU-T G.992.3].

L.3.7 Control parameters

The configuration of the PTM-TC function is controlled by a set of control parameters defined in Table L.15 in addition to those specified in the main body of this Recommendation. The values of these control parameters shall be set and communicated during initialization or reconfiguration (if applicable) of a VTU pair. All the values are determined by application requirements and means that are beyond the scope of this Recommendation.

Table L.15 – PTM-TC parameters

Parameter	Definition
Minimum net data rate net_min_n	The minimum net data rate supported by the PTM-TC stream # n . The VTU shall implement appropriate initialization and reconfiguration procedures to provide net_min_n data rate.
Maximum net data rate net_max_n	The maximum net data rate supported by PTM-TC stream # n . During initialization and reconfiguration procedures, the net data rate shall not exceed this value.
Minimum SOS net data rate $MIN-SOS-BR_n$	The minimum net data rate required by the PTM-TC stream # n for a valid SOS request (see clause 13.4).
Minimum reserved data rate $net_reserve_n$	The minimum reserved data rate supported by PTM-TC stream # n that shall always be available upon request by an appropriate reconfiguration procedure. The value of $net_reserve_n$ shall be constrained such that $net_min_n \leq net_reserve_n \leq net_max_n$. This parameter is not used in this version of this Recommendation and shall be set to net_min_n . The OLR procedures that utilize this parameter will be defined in a future revision of this Recommendation.
Maximum PMS-TC latency $delay_max_n$	The PTM-TC stream # n shall be transported with underlying PMS-TC functions configured such that the derived parameter $delay_p$ is no larger than this control parameter $delay_max_n$.
Minimum PMS-TC impulse noise protection INP_min_n	The PTM-TC stream # n shall be transported with underlying PMS-TC functions configured such that the derived parameter INP_p is not lower than this control parameter INP_min_n .
Channel initialization policy $CIpolicy_n$	This parameter controls the policy to be applied in setting the transceiver configuration parameters during initialization (see clause 12.3.7).
Maximum delay variation DV_max_n	The PTM-TC stream # n shall be transported with underlying PMS-TC OLR function as defined in clause 13.4 such that the derived parameter DV_p is not lower than this control parameter DV_max_n .

If the values of net_min_n , net_max_n , and $net_reserve_n$ (see Table 12-54) are set to the same value, then the PTM-TC stream is designated as a fixed data rate PTM-TC stream (i.e., RA-MODE = MANUAL, see Table 12-49). If $net_min_n = net_reserve_n$ and $net_min_n \neq net_max_n$, then the PTM-TC stream is designated as a flexible data rate PTM-TC stream. If the value of $net_min_n \neq net_max_n \neq net_reserve_n$, then the PTM-TC stream is designated as a flexible data rate PTM-TC stream with reserved data rate allocation.

During initialization and reconfiguration procedures (except SOS), the actual net data rate net_act_n for stream # n shall always be set to the value of the derived parameter NDR_{pn} of the underlying PMS-TC latency path function and shall be constrained such that $net_min_n \leq net_act_n \leq net_max_n$. However, in case the $net_min_n = net_max_n$, the net_act_n may exceed the net_max_n by up to 8 kbit/s, to allow for the PMS-TC net data rate granularity (see Table 5-1). If $net_min_n < net_max_n$, the net_max_n shall be set at least 8 kbit/s above the net_min_n , to allow for the PMS-TC net data rate granularity to meet the $net_min_n \leq net_act_n \leq net_max_n$ requirement. The actual latency $delay_act_n$ of transport of stream # n shall always be set to the value of the derived parameter $delay_p$ of the underlying PMS-TC latency path function and constrained such that $delay_act_n \leq delay_max_n$.

The actual impulse noise protection INP_act_n of transport of stream # n shall always be set to the value of the derived parameter INP_p of the underlying PMS-TC path function and constrained such that $INP_act_n \geq INP_min_n$. The values net_act_n , $delay_act_n$ and INP_act_n are not control parameters; these values are the result of specific initialization and reconfiguration procedures.

During SOS reconfiguration procedures, the net data rates, INP and delay shall comply with clause 13.4.

L.3.7.1 Valid configuration

The configurations listed in Table L.16 are valid for the PTM-TC function.

Table L.16 – Valid configuration for PTM-TC function

Parameter	Capability
$type_n$	3
net_min_n	net_min_n may be supported for all valid framing configurations.
net_max_n	net_max_n may be supported for all valid framing configurations.
$net_reserve_n$	$net_reserve_n$ may be supported for all valid framing configurations.
$MIN-SOS-BR_n$	$MIN-SOS-BR_n$ may be supported for all valid framing configurations.
$delay_max_n$	All valid values of $delay_max_n$ (see Table 12-51).
INP_min_n	All valid values of INP_min_n (see Table 12-51).
$CIpolicy_n$	0, 1, 2

L.3.7.2 Mandatory configurations

If implementing a PTM-TC function, a VTU shall support all combinations of the values of PTM-TC control parameters for PTM-TC function #0 displayed in Tables L.17 and L.18 in the downstream and upstream directions, respectively. The transmitter and receiver shall support mandatory features displayed in these tables and in Table L.19.

Table L.17 – Mandatory downstream configuration for PTM-TC function #0

Parameter	Capability
$type_n$	3
$delay_max_n$	All valid values shall be supported.
INP_min_n	All valid values shall be supported.
$CIpolicy_n$	0

Table L.18 – Mandatory upstream configuration for PTM-TC function #0

Parameter	Capability
$type_n$	3
$delay_max_n$	All valid values shall be supported.
INP_min_n	All valid values shall be supported.

Table L.19 – Mandatory bidirectional configuration for PTM-TC function

Parameter	Capability
<i>bi_net_min</i>	<i>bi_net_min</i> shall be supported for all valid framing configurations up to and equal to the MBDC defined in clause 6.2.7 for the applicable profile.
<i>bi_net_max</i>	<i>bi_net_max</i> shall be supported for all valid framing configurations up to and equal to the MBDC defined in clause 6.2.7 for the applicable profile.
<i>bi_net_reserve</i>	<i>bi_net_reserve</i> shall be supported for all valid framing configurations up to and equal to the MBDC defined in clause 6.2.7 for the applicable profile.

L.3.8 Functionality

The functionality of the PTM-TC shall implement 64/65-octet encapsulation as defined in Annex N of [ITU-T G.992.3], and shall include encapsulation, packet error monitoring, data rate decoupling, and frame delineation.

For frame error monitoring, the transmitting PTM-TC shall insert the 16-bit CRC defined in clause N.3.3 of [ITU-T G.992.3].

L.3.9 Management plane procedures

L.3.9.1 Surveillance primitives

See clause N.4 of [ITU-T G.992.3].

L.3.9.2 Indicator bits

The indicator bits for TPS-TC #*n* and bearer channel #*n* (*n* = 0 or 1) are defined in clause 9.5.2.2. The TIB#*n*-0, TIB#*n*-1, TIB#*n*-2 and TIB#*n*-3 shall be set to a 1 for use in Table 9-5.

L.3.9.3 Overhead command formats

L.3.9.3.1 Inventory command

For further study.

L.3.9.3.2 Control Value Read command

For further study.

L.3.9.3.3 Management Counter Read command

The TPS-TC octets in the response to the overhead Management Counter Read command corresponding to the PTM-TC function are under study. The block of counter values corresponding to the PTM-TC function returned in the message described in Table 11-18 shall have zero length.

L.3.10 Initialization procedure

The PTM-TC shall be configured during initialization using the same procedure described in clause L.1.10.

L.3.11 On-line reconfiguration

The on-line reconfiguration of the PTM-TC is outside the scope of this Recommendation. There is no specified mechanism to modify the value of the control parameters of the PTM-TC function. The values of *net_act* and *delay_act* are automatically updated from the underlying PMS-TC latency path function.

L.3.11.1 Changes to an existing stream

Update of the *net_act* and *delay_act* parameters of an existing PTM-TC function shall only occur at octet boundaries. The transmit PTM-TC function uses the new values of the *net_act*, and *delay_act* to generate octets that follow the signalling of the Frame.Synchflag.confirm primitive. The receive PTM-TC function procedures process octets that follow the signalling of the Frame.Synchflag.indicate primitive using the new values of these parameters.

Annex M

Time-of-day distribution over VDSL2 links

(This annex forms an integral part of this Recommendation.)

This annex defines the procedure for distribution of time-of-day across a VDSL2 link. Each section in this annex identifies the corresponding clause in the main body for which supplements or amendments are made in support of time-of-day distribution over VDSL2 links.

M.1 Time-of-day distribution operational overview

See clause 8.4.1.

M.2 Definitions

See clause 3.

M.3 Abbreviations

See clause 4.

M.4 VTU functional model

See clause 5.1.

M.5 TPS-TC function

See clause 8 (i.e., text between headings of clause 8 and clause 8.1).

M.6 eoc communication protocol

See clause 8.2.4.1.

M.7 ToD TPS-TC (ToD-TC)

See clause 8.4.

M.8 Mapping of OH data

See clause 9.5.2.2.1.

M.9 eoc transmission protocol

See clause 11.2.2 (transmission protocol).

See clause 11.2.3.2 (Command and response types).

M.10 Frequency synchronization command

See clause 11.2.3.14.

M.10.1 The eoc data rate to transport the ToD phase difference values (informative)

This informative clause contains a calculation of the required eoc data rate to transport the ToD phase difference values.

The model of the eoc transmitter is shown in Figure M.1. Two cases are illustrated in Figure M.2.

- Case 1: Transfer of high priority message ongoing when ToD frequency synchronization message is to be sent.

- Case 2: Transfer of lower priority message ongoing when ToD frequency synchronization message is to be sent.

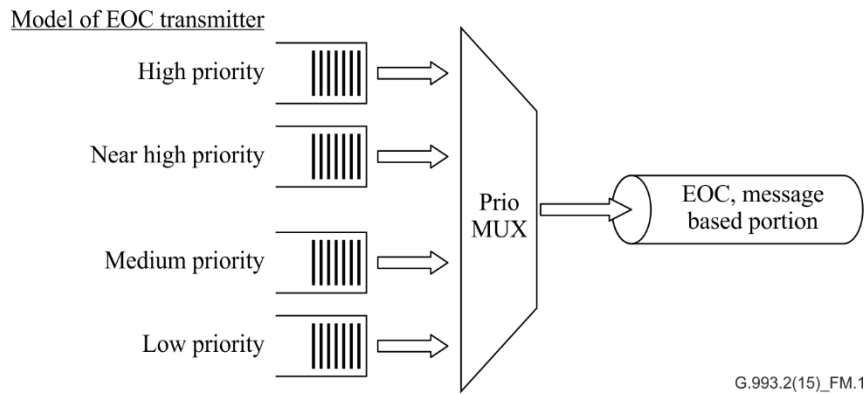

G.993.2(15)_FM.1

Figure M.1 – Model of the eoc transmitter

Case 1: Transfer of higher priority message ongoing when frequency synchronization message is to be sent

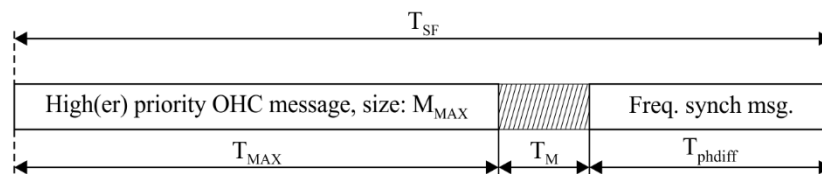

Case 2: Transfer of lower priority message ongoing when frequency synchronization message is to be sent

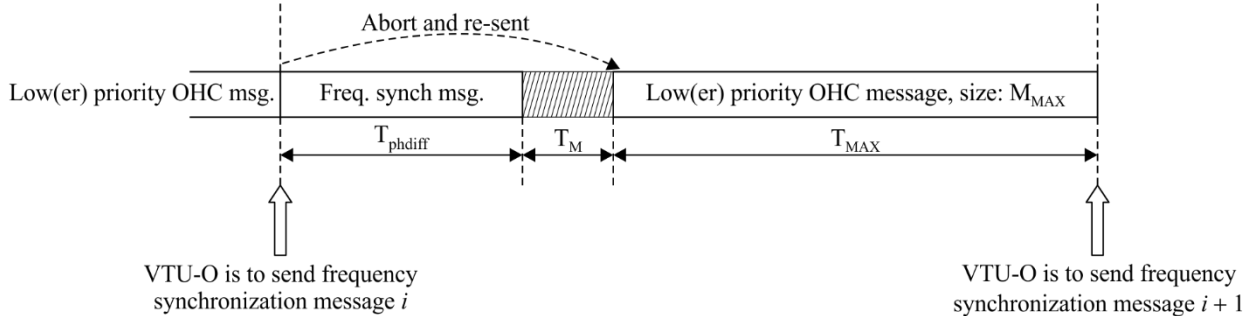

G.993.2(15)_FM.2

Figure M.2 – Two cases of ongoing transfers

Variables and Calculation:

msg_p [Kbit/s] message overhead data rate (Table 9-8)

M_{max} [Octets] maximum size of any eoc message fragment (1 024 octets, see clause 11.2.3.1)

M_{phdiff} [Octets] size of periodic ToD frequency synchronization message

T_{SF} [s] repetition period of time synchronization messages

f_{DMT} [kHz] DMT symbol rate (clause 10.4.4.)

$T_{SF} = \frac{n \times 257}{f_{DMT}}$ with n being agreed between VTUs during initialization
($n = 1, 2 \dots 255$)

T_{max} [s] time required for transmission of message of size M_{max}

T_{phdiff} [s] time required for transmission of message of size M_{phdiff}

$T_m = \alpha \times T_{max}$ α denoting a percentage of T_{max} to be considered as margin T_m . The margin takes care for HDLC framing overhead and software reaction times when scheduling OHC messages.

Condition for deterministic exchange of periodic message along with maximum sized messages:

$$T_{SF} \geq T_{max} + T_{phdiff} + T_m$$

with $msg_p \times T_{max} = M_{max}$ and equivalent for the other contributors, the condition is expressed as

$$msg_p \geq \frac{8}{T_{SF}} \times (M_{phdiff} + (1 + \alpha) \times M_{max})$$

considering the operator configured parameter msg_{min} in addition:

$$msg_p \geq \min \left\{ \frac{8}{T_{SF}} \times (M_{phdiff} + (1 + \alpha) \times M_{max}); msg_{min} \right\} \quad (M.1)$$

Using typical values for the aforementioned parameters, the following table can be generated:

n	f_s [kHz]	T_{SF} [s]	M_{phdiff}	M_{max} [Oct]	α	msg_{min} [Kbit/s]	msg_p [Bit/s]	msg_p [Kbit/s]	Percentage of eoc bandwidth for phase difference [%]
1	4	0.06425	5	512	0.1	16	70 749	71	0.9

M.11 Time synchronization command and responses

See clause 11.2.3.15.

M.12 Updates to initialization

See clause 12.3.5.2 (SOC messages exchanged during channel analysis and exchange phase).

See 12.3.5.2.1.1 (O-MSG 1 field #27).

See 12.3.5.2.1.2 (O-TPS field #7).

See 12.3.5.2.2.1 (R-MSG 2 fields #9 and #10).

Annex N

Region D (China)

(This annex forms an integral part of this Recommendation.)

N.1 Band plans

This annex defines the band plan for the Chinese region for VDSL2 systems operating at a maximum frequency of 17.66MHz. The band plan is defined in Table N.1 below and can be summarized as follows:

Plan CN17 Band plan to $f_{max} = 17.664$ MHz

Different variants are defined for band plan CN17 to accommodate different underlying services (POTS and ISDN), and different US0 bandwidths.

Table N.1 – Band-edge frequencies for Chinese VDSL2 band plans

Band plan	Band-edge frequencies (as defined in the generic band plan in clause 7.1.2)						
	f_{0L} kHz	f_{0H} kHz	f_1 kHz	f_2 kHz	f_3 kHz	f_4 kHz	f_5 kHz
	US0		DS1	US1	DS2		US2
CN17	25	138	138	3 750	5 200	14 200	17 664
	120	276	276				
	25	276	276				
	N/A	N/A	276				
NOTE 1 – N/A in the columns f_{0L} and f_{0H} designates a band plan variant that does not use US0. NOTE 2 – The capability to support US0 together with profile 17a is required for Chinese VDSL2.							

The f_i in Table N.1 are defined as follows:

- f_{0L} and f_{0H} : define lower and upper frequency of US0;
- f_1 to f_3 are the boundary frequencies of the bands DS1 and US1 as defined for CN17.
- f_4 to f_5 are the boundary frequencies of the bands DS2 and US2 for CN17.

N.2 Limit PSD mask options

The limit PSD mask options defined in this Annex are shown in Table N.2, for various band plans.

Table N.2 – Chinese limit PSD mask options for band plan CN17

Short name	Limit PSD mask (long name)	Frequency	
		US0 type A/B/M (Note)	Highest used upstream or downstream frequency (kHz)
D-1	CN17-M2x-A	A	17 664
D-2	CN17-M2x-B	B	17 664
D-3	CN17-M2x-M	M	17 664
D-4	CN17- M2x-NUS0-M	N/A	17 664
NOTE – The US0 types stand for: <ul style="list-style-type: none"> • US0 type A corresponds to Annex A of [ITU T G.993.2 Annex B]; • US0 type B corresponds to Annex B of [ITU T G.993.2 Annex B]; • US0 type M corresponds to Annex M of [ITU T G.993.2 Annex B]; • US0 type N/A designates a band plan variant that does not use US0; • CN17-M2x-NUS0-M designate the variants in which DS1 starts at 276 kHz instead of 138 kHz. 			

N.2.1 General requirements in the band below 4 kHz

The noise in the voice band measured with psophometric weighting according to [ITU-T O.41] clause 3.3 shall not exceed –6dBm. The psophometer shall be used in bridging mode and shall be calibrated for 600 ohm termination.

N.2.2 VTU-R limit PSD masks for band plan CN17

The VTU-R limit PSD masks for band plan CN17 are shown in Table N.3.

Table N.3 – VTU-R limit PSD masks for band plan CN17

Name	D-1	D-2	D-3	D-4
Long name	X17-M2x-A	X17-M2x-B	X17-M2x-M	X17- M2x-NUS0-M
kHz	dBm/Hz	dBm/Hz	dBm/Hz	dBm/Hz
0	–97.5	–97.5	–97.5	–100
4	–97.5	–97.5	–97.5	–100
4	–92.5	–92.5	–92.5	–100
25.875	–34.5	–92.5	–37.5	–100
50	–34.5	–90	–37.5	–100
80	–34.5	–81.8	–37.5	–100
120	–34.5	–34.5	–37.5	–100
138	–34.5	–34.5	–37.5	–100
225	Interp	–34.5	–37.5	–100
243	–93.2	–34.5	–37.5	–100
276	Interp	–34.5	–37.5	–100

Table N.3 – VTU-R limit PSD masks for band plan CN17

Name	D-1	D-2	D-3	D-4
Long name	X17-M2x-A	X17-M2x-B	X17-M2x-M	X17- M2x-NUS0-M
kHz	dBm/Hz	dBm/Hz	dBm/Hz	dBm/Hz
307	Interp	Interp	Interp	-100
493.41	Interp	Interp	-97.9	-100
508.8	Interp	-98	Interp	-100
686	-100	-100	-100	-100
3 575	-100	-100	-100	-100
3 750	-80	-80	-80	-80
3 750	-51.2	-51.2	-51.2	-51.2
5 100	Interp	Interp	Interp	Interp
5 200	-52.7	-52.7	-52.7	-52.7
5 200	-80	-80	-80	-80
5 375	-100	-100	-100	-100
8 325	-100	-100	-100	-100
8 500	-100	-100	-100	-100
8 500	-100	-100	-100	-100
10 000	-100	-100	-100	-100
12 000	-100	-100	-100	-100
12 000	-100	-100	-100	-100
12 175	-100	-100	-100	-100
14 000	-100	-100	-100	-100
14 000	-100	-100	-100	-100
14 200	-80	-80	-80	-80
14 200	-56.5	-56.5	-56.5	-56.5
15 700	-56.5	-56.5	-56.5	-56.5
17 664	-56.5	-56.5	-56.5	-56.5
21 000	-80	-80	-80	-80
21 450	-100	-100	-100	-100
21 450	-100	-100	-100	-100
24 715	-100	-100	-100	-100
24 890	-100	-100	-100	-100
24 890	-100	-100	-100	-100
25 065	-100	-100	-100	-100
30 000	-100	-100	-100	-100
30 000	-110	-110	-110	-110
30 175	-110	-110	-110	-110
≥ 30 175	-110	-110	-110	-110

Table N.3 – VTU-R limit PSD masks for band plan CN17

Name	D-1	D-2	D-3	D-4
Long name	X17-M2x-A	X17-M2x-B	X17-M2x-M	X17- M2x-NUS0-M
kHz	dBm/Hz	dBm/Hz	dBm/Hz	dBm/Hz
NOTE – The PSD values between breakpoints including the values marked by "Interp" shall be obtained by interpolation between adjacent breakpoints as follows:				
– below 3575 kHz on a dB/log(<i>f</i>) basis; and				
– above 3575 kHz on a dB/ <i>f</i> basis.				

N.2.3 VTU-O limit PSD masks for band plan CN17

The VTU-O limit PSD masks for band plan CN17 are shown in Table N.4.

Table N.4 – VTU-O limit PSD masks for band plan CN17

Name	D-1	D-2	D-3	D-4
Long name	X17-M2x-A	X17-M2x-B	X17-M2x-M	X17- M2x-NUS0-M
kHz	dBm/Hz	dBm/Hz	dBm/Hz	dBm/Hz
0	–97.5	–97.5	–97.5	–97.5
4	–97.5	–97.5	–97.5	–97.5
4	–92.5	–92.5	–92.5	–92.5
80	–72.5	–92.5	–92.5	–92.5
101.2	Interp	–92.5	–92.5	–92.5
138	–44.2	Interp	Interp	Interp
138	–36.5	Interp	Interp	Interp
227.11	–36.5	–62	–62	–62
276	–36.5	–48.5	–48.5	–48.5
276	–36.5	–36.5	–36.5	–36.5
1 104	–36.5	–36.5	–36.5	–36.5
1 622	–46.5	–46.5	–46.5	–46.5
2 208	–48	–48	–48	–48
2 249	Interp	Interp	Interp	Interp
2 500	Interp	Interp	Interp	Interp
3 750	–51.2	–51.2	–51.2	–51.2
3 750	–80	–80	–80	–80
3 925	–100	–100	–100	–100
5 025	–100	–100	–100	–100
5 200	–80	–80	–80	–80
5 200	–52.7	–52.7	–52.7	–52.7
7 050	Interp	Interp	Interp	Interp
7 225	Interp	Interp	Interp	Interp
8 500	–54.8	–54.8	–54.8	–54.8
10 000	–55.5	–55.5	–55.5	–55.5

Table N.4 – VTU-O limit PSD masks for band plan CN17

Name	D-1	D-2	D-3	D-4
Long name	X17-M2x-A	X17-M2x-B	X17-M2x-M	X17- M2x-NUS0-M
kHz	dBm/Hz	dBm/Hz	dBm/Hz	dBm/Hz
12 000	-55.5	-55.5	-55.5	-55.5
12 000	-56.5	-56.5	-56.5	-56.5
13 825	-56.5	-56.5	-56.5	-56.5
14 000	-56.5	-56.5	-56.5	-56.5
14 200	-56.5	-56.5	-56.5	-56.5
14 200	-80	-80	-80	-80
17 664	-100	-100	-100	-100
21 000	-100	-100	-100	-100
21 450	-100	-100	-100	-100
21 450	-100	-100	-100	-100
21 625	-100	-100	-100	-100
24 715	-100	-100	-100	-100
24 890	-100	-100	-100	-100
24 890	-100	-100	-100	-100
25 065	-100	-100	-100	-100
30 000	-100	-100	-100	-100
30 000	-110	-110	-110	-110
30 175	-110	-110	-110	-110
≥ 30 175	-110	-110	-110	-110

NOTE – The PSD values between breakpoints including the values marked by "Interp" shall be obtained by interpolation between adjacent breakpoints as follows:

- below f_1 on a dB/log(f) basis; and
- above f_1 on a dB/ f basis,

where f_1 is defined in Table N.1 as either 138 or 276 kHz.

N.3 UPBO reference PSDs

UPBO parameters 'a' and 'b' are set by network management.

NOTE – The parameters 'a' and 'b' are expected to be uniform across all lines sharing a section of cable plant.

N.4 Template PSD

N.4.1 Definition

The template PSD is set to 3.5 dB below the PSD mask in frequency bands in which the PSD is at or above -96.5 dBm/Hz. Elsewhere the template is set to -100 dBm/Hz below 4 MHz, -110 dBm/Hz between 4 MHz and f_3 , or -112 dBm/Hz between f_3 and 30 MHz, where f_3 is defined in Table N.1. These values are chosen to satisfy the requirements of clause 7.2.2 in ITU-T G.993.2.

N.4.2 Narrow-band PSD verification

Narrow-band compliance with the PSD masks in this annex shall be verified by power measurements using a 10-kHz measurement bandwidth centred on the frequency in question above 4 kHz, and in a 100-Hz measurement bandwidth in the band up to 4 kHz.

N.4.3 Use in simulation (informative)

The Template PSD may be used in simulations of VDSL2 performance as representative of an average transmitter conformant with the associated limit PSD mask.

N.5 Compliance

Compliance requires conformance with at least one limit PSD mask.

Annex O

This annex is intentionally left blank.

Annex P

Short reach VDSL2 with reduced power and enhanced data rate

(This annex forms an integral part of this Recommendation.)

P.1 Scope

This annex defines the functional requirements for implementations of ITU-T G.993.2 with reduced power and enhanced data rates over a short reach (e.g., for deployment from the distribution point (DP)). The defined functionalities concern the transmit power, support of enhanced net data rates in [ITU-T G.998.4], SRA and TPS-TC. Other functionalities are for further study.

P.2 Reduced ATP

A VTU-O compliant with this annex may indicate in the ITU-T G.993.2 discovery phase a MAXNOMATPds parameter value that is lower than the maximum aggregate downstream transmit power in the VDSL2 profile (see Tables 12-21 and 6-1), and lower than the MAXNOMATPds value configured in the CO-MIB (see clause 7.3.1.2.3 of [ITU-T G.997.1]).

NOTE – The VTU-O MAXNOMATPds parameter value may be lowered due to a specific deployment scenario.

P.3 Minimum bidirectional net data rate capability

A VTU compliant with this annex shall comply with the following minimum bidirectional net data rate capability for the profiles listed in Table P.1. These values supersede the values specified in Table 6-1.

Table P.1 – Annex P profiles

Frequency plan	Parameter	Parameter value for profile	
		17a	30a
All	Minimum bidirectional net data rate capability (MBDC)	150 Mbit/s	250 Mbit/s

NOTE – For the profile 30a in operation according to Annex B, it is recommended that the Limit Mask PSD B8-16 (long name 998ADE30-M2x-NUS0-A) is configured in the CO-MIB.

Support of profile 30a is mandatory for compliance with this annex. Support of profile 17a is optional.

P.4 ITU-T G.998.4 Annex D support for enhanced net data rates with ITU-T G.998.4

Support for ITU-T G.998.4 downstream retransmission is mandatory for a VTU compliant with this annex.

Support for ITU-T G.998.4 upstream retransmission is optional for a VTU compliant with this annex.

A VTU compliant with this annex shall support Annex D of ITU-T G.998.4 without requiring bit "ITU-T G.993.5" (see Table 11.68.0.1 of ITU-T G.994.1) to be set to ONE in the Spar(2) octet 2 of ITU-T G.993.2 at the VTU-O.

A VTU-O compliant with this annex shall set the bit "ITU-T G.998.4 Annex D support" (see Table 11.68.11 of [ITU-T G.994.1]) to ONE in the "ITU-T G.998.4 extensions" NPar(3) field of the CL message.

A VTU-R compliant with this annex shall set the bit "ITU-T G.998.4 Annex D support" (see Table 11.68.11 of [ITU-T G.994.1]) to ONE in the "ITU-T G.998.4 extensions" NPar(3) field of the CLR message.

A VTU-O compliant with this annex shall support an `AggAchievableNDR_O` equal to the `MaxAggAchievableNDR` as defined in Annex D of [ITU-T G.998.4] for the respective VDSL2 profile.

If a VTU-R compliant with this annex supports ITU-T G.998.4 upstream retransmission, it shall support an `AggAchievableNDR_R` equal to the `MaxAggAchievableNDR`, as defined in Annex D of [ITU-T G.998.4] for the respective VDSL2 profile.

P.5 SRA support

A VTU-O compliant with this annex shall support OLR type 3

- in downstream (i.e., bit `s=1` in the field "Downstream OLR capabilities" (see Table 12-52) of the "PMS-TC capabilities of the VTU-O" field in O-MSG1), and
- in upstream (i.e., bit `s=1` in the field "Upstream OLR capabilities" (see Table 12-52) of the "PMS-TC capabilities of the VTU-O" field in O-MSG1).

A VTU-O compliant with this annex shall support OLR type 5

- in downstream (i.e., bit `s=1` in field #7 "Downstream OLR capabilities with ITU-T G.998.4" (see Table C.4 of [ITU-T G.998.4]) of the "ITU-T G.998.4 parameter field for O-PMS"), and
- in upstream (i.e., bit `s=1` in field #8 "Upstream OLR capabilities with ITU-T G.998.4" (see Table C.4 of [ITU-T G.998.4]) of the "ITU-T G.998.4 parameter field for O-PMS").

A VTU-R compliant with this annex shall support OLR type 3

- in downstream (i.e., bit `s=1` in the field "Downstream OLR capabilities" (see Table 12-62) of the "PMS-TC capabilities of VTU-R" field in R-MSG2), and
- in upstream (i.e., bit `s=1` in the field "Upstream OLR capabilities" (see Table 12-62) of the "PMS-TC capabilities of VTU-R" field in R-MSG2).

A VTU-R compliant with this annex shall support OLR type 5 in downstream (i.e., bit `s=1` in field #7 "Downstream OLR capabilities with ITU-T G.998.4" (see Table C.6 of [ITU-T G.998.4]) of the "ITU-T G.998.4 parameter field for R-PMS").

If a VTU-R compliant with this annex supports ITU-T G.998.4 upstream retransmission, it shall support OLR type 5 in upstream (i.e., bit `s=1` in field #8 "Upstream OLR capabilities with ITU-T G.998.4" (see Table C.6 of [ITU-T G.998.4]) of the "ITU-T G.998.4 parameter field for R-PMS").

P.6 TPS-TC

Support of PTM-TC is mandatory for a VTU compliant with this annex.

Annex Q

Enhanced data rate 35 MHz VDSL2 with 4.3125 kHz subcarrier spacing

(This annex forms an integral part of this Recommendation.)

Q.1 Scope

This annex defines functional requirements for implementations of ITU-T G.993.2 operating on frequencies up to 35.324 MHz with subcarrier spacing of 4.3125 kHz, supporting vectoring that is compatible with ITU-T G.993.2 profile 17a. The defined functionalities concern capabilities related to the profile, support of enhanced net data rates in ITU-T G.998.4, SRA and TPS-TC. Other functionalities are for further study.

Q.2 Capabilities related to the profile

A VTU compliant with this annex shall comply with the following capabilities related to the profiles listed in Table Q.1. The profile 17a values supersede the values specified in Table 6-1. The profile 35b values shall be equal to the profile 30a values listed in Table 6-1, with differences specified in Table Q.1.

Table Q.1 – Annex Q profiles

Frequency plan	Parameter	Parameter value for profile	
		17a	35b (Note)
All	Maximum aggregate downstream transmit power (dBm)	<i>(no change)</i>	+17
All	Subcarrier spacing (kHz)	<i>(no change)</i>	4.3125
All	Support of upstream band zero (US0)	<i>(no change)</i>	Regional annex dependent
All	Minimum bidirectional net data rate capability (MBDC)	150 Mbit/s	400 Mbit/s
All	Parameter (1/S)max downstream	<i>(no change)</i>	48
All	Parameter (1/S)max upstream	<i>(no change)</i>	24
Annex B (998ADE)	Index of highest supported downstream data-bearing subcarrier (upper band edge frequency in MHz (informative))	<i>(no change)</i>	8191 (35.324)
	Index of highest supported upstream data-bearing subcarrier (upper band edge frequency in MHz (informative))	<i>(no change)</i>	2782 (12.0)

Table Q.1 – Annex Q profiles

Frequency plan	Parameter	Parameter value for profile	
		17a	35b (Note)
Annex B (998E)	Index of highest supported downstream data-bearing subcarrier (upper band edge frequency in MHz (informative))	(no change)	8191 (35.324)
	Index of highest supported upstream data-bearing subcarrier (upper band edge frequency in MHz (informative))	(no change)	3246 (14.0)
NOTE – Band plans associated with this profile shall have an index of highest supported upstream data-bearing subcarrier not higher than 4095.			

Support of profile 35b is mandatory for compliance with this annex. Support of profile 17a is optional.

Q.3 ITU-T G.998.4 Annex D support for enhanced net data rates

Support for ITU-T G.998.4 downstream retransmission is mandatory for a VTU compliant with this annex.

NOTE 1 - Setting $RTX_MODEd = 0$ ($RTX_FORBIDDEN$: ITU-T G.998.4 retransmission not allowed) may result in reduced bit rates and impulse noise protection, and thus is not recommended.

Support for ITU-T G.998.4 upstream retransmission is optional for a VTU compliant with this annex.

A VTU compliant with this annex shall support Annex D of [ITU-T G.998.4] without requiring bit "ITU-T G.993.5" (see Table 11.68.0.1 of [ITU-T G.994.1]) to be set to ONE in the Spar(2) octet 2 of ITU-T G.993.2 at the VTU-O.

A VTU-O compliant with this annex shall set the bit "ITU-T G.998.4 Annex D support" (see Table 11.68.11 of [ITU-T G.994.1]) to ONE in the "ITU-T G.998.4 extensions" NPar(3) field of the CL message.

A VTU-R compliant with this annex shall set the bit "ITU-T G.998.4 Annex D support2" (see Table 11.68.11 of [ITU-T G.994.1]) to ONE in the 2ITU-T G.998.4 extensions2 NPar(3) field of the CLR message.

The reference half roundtrip (HRT_{ref}) values for determining $AggAchievableNDR_O$ are the following:

- Profile 17a: $HRT_{ref} = 8$ DMT symbols
- Profile 35b: $HRT_{ref} = 6$ DMT symbols

The reference half roundtrip (HRT_{ref}) values for determining $AggAchievableNDR_R$ are the following:

- Profile 17a: $HRT_{ref} = 8$ DMT symbols
- Profile 35b: $HRT_{ref} = 7$ DMT symbols

NOTE 2 - With nominal values of CE, the HRT_{ref} of 8 symbols, 7 symbols, and 6 symbols are equal to 2 ms, 1.75 ms and 1.5 ms, respectively.

The maximum aggregate achievable net data rate ($MaxAggAchievableNDR$, see clause D.1.1.1 of [ITU-T G.998.4]) for each profile, are the following:

- Profile 17a = 150 Mbit/s;
- Profile 35b = 400 Mbit/s.

A VTU-O compliant with this annex with support for ITU-T G.998.4 upstream retransmission, shall support an `AggAchievableNDR_O` (see clause D.1.1.1 of [ITU-T G.998.4]) equal to the `MaxAggAchievableNDR` for the profile 17a and equal to 355 Mbit/s for the profile 35b.

A VTU-R compliant with this annex with support of ITU-T G.998.4 upstream retransmission, shall support an `AggAchievableNDR_R` (see clause D.1.1.1 of [ITU-T G.998.4]) equal to the `MaxAggAchievableNDR` for the profile 17a and equal to 355 Mbit/s for the profile 35b.

For profile 35b, the valid values for (derived) framing parameters shall be as listed in Table 9-9, Table 9-3 of [ITU-T G.998.4] and Table C.1 of [ITU-T G.998.4] for profile 30a, with differences shown in Table Q.2.

Table Q.2 – Valid values for profile 35b

Parameter	downstream	upstream
DTU size after FEC in symbols ($Q \times S_1$) (see Table 9.3 of [ITU-T G.998.4])	$1/3 \leq Q \times S_1 \leq 4$	(no change)
DTU size ($Q \times H$) (see Table C.1 of [ITU-T G.998.4])	≤ 4096	(no change)
FEC codewords per symbol ($1/S$) (see Table 9-9)	≤ 48	≤ 24

Q.4 SRA support

A VTU-O compliant with this annex shall support OLR Type 3

- in downstream (i.e., bit s=1 in the Field "Downstream OLR capabilities" (see Table 12-52) of the "PMS-TC capabilities of the VTU-O" field in O-MSG1), and
- in upstream (i.e., bit s=1 in the Field "Upstream OLR capabilities" (see Table 12-52) of the "PMS-TC capabilities of the VTU-O" field in O-MSG1).

A VTU-O compliant with this annex shall support OLR Type 5

- in downstream (i.e., bit s=1 in Field #7 "Downstream OLR capabilities with ITU-T G.998.4" (see Table C.4 of [ITU-T G.998.4]) of the "G.998.4 parameter field for O-PMS") and
- in upstream (i.e., bit s=1 in Field #8 "Upstream OLR capabilities with ITU-T G.998.4" (see Table C.4 of [ITU-T G.998.4]) of the "G.998.4 parameter field for O-PMS").

A VTU-R compliant with this annex shall support OLR Type 3

- in downstream (i.e., bit s=1 in the Field "Downstream OLR capabilities" (see Table 12-62) of the "PMS-TC capabilities of VTU-R" field in R-MSG2), and
- in upstream (i.e., bit s=1 in the Field "Upstream OLR capabilities" (see Table 12-62) of the "PMS-TC capabilities of VTU-R" field in R-MSG2).

A VTU-R compliant with this annex shall support OLR Type 5 in downstream (i.e., bit s=1 in Field #7 "Downstream OLR capabilities with ITU-T G.998.4" (see Table C.6 of [ITU-T G.998.4]) of the "G.998.4 parameter field for R-PMS").

If a VTU-R compliant with this annex supports G.998.4 upstream retransmission, it shall support OLR Type 5 in upstream (i.e., bit s=1 in Field #8 "Upstream OLR capabilities with ITU-T G.998.4" (see Table C.6 of [ITU-T G.998.4]) of the "ITU-T G.998.4 parameter field for R-PMS").

Q.5 TPS-TC

Support of PTM-TC is mandatory for a VTU compliant with this annex.

Q.6 Additional changes to ITU-T G.993.2 for operation according to profile 35b

NOTE – This clause uses revision marks where changes are made relative to the approved text. Unchanged text is replaced by ellipsis (...).

The U reference point specification for operation according to profile 35b shall be the same as specified in the main body of this Recommendation, with differences listed in this clause.

9.5.4 Framing parameters

...

Table 9-8 – Framing parameters for latency path p

Parameter	Definition
$PERB_p$	<p>The number of bytes in the overhead frame:</p> $PERB_p = \frac{T_p \times N_{FECp}}{M_p} \times \left\lfloor \frac{\hat{Q} \times M_p}{T_p \times N_{FECp}} \right\rfloor \text{ bytes}$ <p>where:</p> $\hat{Q} = \begin{cases} Q & \text{if } TDR_p \geq TDR_0 \\ Q \cdot \frac{TDR_p}{TDR_0} & \text{if } TDR_p < TDR_0 \end{cases}$ <p>and where:</p> <p>TDR_p is the total data rate of latency path p in kbit/s, $Q = 17\,000$ bytes for upstream and $34\,000$ bytes for downstream, $TDR_0 = 7\,880$ kbit/s for upstream and $15\,760$ kbit/s for downstream.</p>

...

10.4.1 Data subcarriers

...

Transmission will take place on NSC subcarriers, with $NSC_{us} \leq MSI_{us}$ and $NSC_{ds} \leq MSI_{ds}$; the subcarrier with index $i=0$ shall not be used. $NSC_{us} + NSC_{ds}$ shall always be less than ~~4096~~8192.

...

10.4.3 Modulation by the inverse discrete Fourier transform (IDFT)

...

The valid values of N are $N = 2^{n+5}$, where n can take integer values from 0 to 78. The values of N used for upstream and downstream are exchanged during initialization (see clauses 12.3.2, 12.3.3.2.1.3, and 12.3.3.2.2.3).

...

11.2.3.3 On-line reconfiguration (OLR) commands and responses

...

Table 11-6 – OLR commands sent by the initiating VTU

Name	Length (octets)	Octet number	Content	Support	
Request Type 3 (SRA) (Note 6)	$5 + 7 N_{LP} + 4 N_f$ ($N_f \leq 128$)	2	06 ₁₆ (Note 1)	Optional <u>Mandatory</u>	
		3 to $2 + 23 N_{LP}$	$23 \times N_{LP}$ octets containing the new L_p values for each of the active latency paths (N_{LP} = number of active latency paths) (Notes 2 and 3)		
		3 + $23 N_{LP}$ to $2 + 45 N_{LP}$	$2 \times N_{LP}$ octets containing the new D_p values for each of the active latency paths (N_{LP} = number of active latency paths) (Note 4)		
		3 + $45 N_{LP}$ to $2 + 56 N_{LP}$	N_{LP} octets containing the new T_p values for each of the active latency paths (N_{LP} = number of active latency paths) (Notes 2, 3, 5)		
		3 + $56 N_{LP}$ to $2 + 67 N_{LP}$	N_{LP} octets containing the new G_p values for each of the active latency paths (N_{LP} = number of active latency paths) (Notes 2, 3, 5)		
		3 + $67 N_{LP}$ to $2 + 78 N_{LP}$	N_{LP} octets containing the new B_{p0} values for each of the active latency paths (N_{LP} = number of active latency paths) (Notes 2, 3, 5)		
		3 + $78 N_{LP}$ to $4 + 78 N_{LP}$	2 octets for the number of subcarriers N_f to be modified		
		5 + $78 N_{LP}$ to $4 + 78 N_{LP} + 4 N_f$	$4 N_f$ octets describing the subcarrier parameter field for each subcarrier		
		5 + $78 N_{LP} + 4 N_f$	1 octet for Segment Code (SC)		
Request Type 4 (SOS)	$N_{TG}/2 + 11$	2	07 ₁₆ (Note 1)	Optional	
		3	Message ID		
		4 to $N_{TG}/2 + 3$	$\Delta b(2)$		$\Delta b(1)$
			$\Delta b(4)$		$\Delta b(3)$
			...		
			$\Delta b(N_{TG})$		$\Delta b(N_{TG} - 1)$
		$N_{TG}/2 + 4$ to $N_{TG}/2 + 56$	New value for L_0		
		$N_{TG}/2 + 67$ to $N_{TG}/2 + 79$	New value for L_1		
$N_{TG}/2 + 810$ to	New value for D_0				

Table 11-6 – OLR commands sent by the initiating VTU

Name	Length (octets)	Octet number	Content	Support
		$N_{TG}/2+9$ <u>11</u>		
		$N_{TG}/2+10$ <u>12</u> to $N_{TG}/2+11$ <u>13</u>	New value for D_1	

...

11.2.3.3 On-line reconfiguration (OLR) commands and responses

...

Each subcarrier parameter field shall contain 4 octets formatted as [0000000i iiiiiiii gggg gggg gggg bbbb] to convey the g_i (12 bits) and the b_i (4 bits) values of the subcarrier index i (1213 bits). The subcarrier index i shall be coded in the fourfive LSBs of the first octet and the entire second octet of the subcarrier field. The LSBs of the subcarrier index i shall be contained in the second octet. The g_i shall be contained in the third octet and the four MSBs of the fourth octet. The LSBs of g_i shall be contained in the fourth octet. The b_i shall be contained in the four LSBs of the fourth octet.

...

11.4.1 Test parameters

...

Valid values of G are 1, 2, 4 and 8 for upstream and 1, 2, 4, 8 and 16 for downstream.

12.2.1 Message format

...

Size in octets	Meaning	Value
1	Flag	7E ₁₆
1	Address field	Message index
1	Control field	Segmentation index
Up to <u>1024</u> <u>2048</u>	Information payload	Payload bytes
1	Frame check sequence	FCS
1	Frame check sequence	FCS
1	Flag	7E ₁₆

Figure 12-4 – Structure of HDLC frames used in the SOC protocol

...

The segmentation index facilitates the message segmentation as described in clause 12.2.6. If no segmentation is used, the segmentation index shall be set to 11₁₆. The number of SOC bytes (before byte stuffing) transmitted in a single HDLC frame shall not exceed 10242048.

...

12.2.2.1 Automatic repeat (AR) mode

...

Table 12-5 – HDLC frames in AR mode

Field	Content
Flag	7E ₁₆
Message index	01 ₁₆
Segmentation index	11 ₁₆ if not segmented; as in clause 12.2.6 if segmented
Information payload	Variable, up to 1024 2048 bytes
FCS	Variable
FCS	Variable
Flag	7E ₁₆

...

12.3.2.1.1 CL messages

...

Table 12-9 – VTU-O CL message NPar(3) bit definitions

ITU-T G.994.1 SPar(2) Bit	Definition of NPar(3) bits
Profiles	Each valid profile is represented by one bit in a field of 89 bits. The valid profiles are: 8a, 8b, 8c, 8d, 12a, 12b, 17a, and 30a and 35b. Each profile supported by the VTU-O is indicated by setting its corresponding bit to ONE.
Initial IDFT Size (2N)	This NPar(3) indicates the initial downstream IDFT size that the VTU-O shall use at the beginning of the channel discovery phase. <u>Bit 5 indicates the use of the extended IDFT size with profile 35b. If set to ONE, it indicates that the IDFT size to be used with profiles 35b is 2N=2×8192. If set to ZERO, it indicates the profile 35b is not supported.</u> <u>The 4 LSBs indicate the IDFT size to be used with any profile other than 35b, encoded as a number from 7 to 13 representing n, where IDFT_sSize 2N = 2ⁿ. If no profile other than 35b is supported, the 4 LSBs shall be set to ZERO.</u>

...

12.3.2.1.2 MS messages

...

Table 12-12 – VTU-O MS message NPar(3) bit definitions

ITU-T G.994.1 SPar(2) Bit	Definition of NPar(3) bits
Profiles	Each valid profile is represented by one bit in a field of 89 bits. The valid profiles are: 8a, 8b, 8c, 8d, 12a, 12b, 17a, and 30a and 35b. The profile selected by the VTU-O is indicated by setting its corresponding bit to ONE.

...

12.3.2.2.1 CLR messages

...

Table 12-15 – VTU-R CLR message NPar(3) bit definitions

ITU-T G.994.1 SPar(2) Bit	Definition of NPar(3) bits
Profiles	Each valid profile is represented by one bit in a field of 89 bits. The valid profiles are: 8a, 8b, 8c, 8d, 12a, 12b, 17a, and 30a and 35b. Each profile supported by the VTU-R is indicated by setting its corresponding bit to ONE.
Initial IDFT Size (2N)	<p>This NPar(3) indicates the initial upstream IDFT size that the VTU-R shall use at the beginning of the channel discovery phase.</p> <p><u>The bit 5 indicates whether the extended IDFT size shall be used with the profile 35b (ONE) or not (ZERO). If set to ONE, the IDFT size to be used with profiles 35b is $2N=2 \times 8192$. If set to ZERO, the IDFT size to be used with profiles 35b is $2N=2 \times 4096$.</u></p> <p><u>The 4 LSBs indicate the IDFT size to be used with any profile other than 35b, encoded as a number from 6 to 13 representing n, where $IDFTsize\ 2N = 2^n$. If no profile other than 35b is supported, the 4 LSBs shall be set to ZERO.</u></p>

...

12.3.2.2.2 MS messages

...

Table 12-18 – VTU-R MS message NPar(3) bit definitions

ITU-T G.994.1 SPar(2) Bit	Definition of NPar(3) bits
Profiles	Each valid profile is represented by one bit in a field of 89 bits. The valid profiles are: 8a, 8b, 8c, 8d, 12a, 12b, 17a, and 30a and 35b. The profile selected by the VTU-R is indicated by setting its corresponding bit to ONE.

...

12.3.3.2.1.1 O-SIGNATURE

...

Fields #2 and #3 shall be formatted as "bands descriptors". The format of the bands descriptor shall be as shown in Table 12-22.

Table 12-22 – Bands descriptor

Octet	Content of field
1	Number of bands to be described
2- <u>45</u>	Bits 0- <u>115</u> : Index of the first subcarrier in band 1 Bits <u>1216-2331</u> : Index of the last subcarrier in band 1
<u>56-79</u> (if applicable)	Bits 0- <u>115</u> : Index of the first subcarrier in band 2 Bits <u>1216-2331</u> : Index of the last subcarrier in band 2
etc.	etc.

The first octet of the bands descriptor shall contain the number of bands to be described. This number can be zero. In that case, there shall be no further octets in the descriptor. If the number of bands is not equal to zero, each group of threefour consecutive octets in the descriptor shall describe the first and last subcarrier in a band.

The first 1216 bits (0-115) in the group of threefour octets shall contain the index of the subcarrier at the lower edge of the band. The last 1216 bits (1216-2331) shall contain the index of the subcarrier at the upper edge of the band. The first and last subcarriers shall be included in the band. For example, a field value 40020018000E00₁₆ means that all subcarriers from 2000E00₁₆ = 5123 584 to 4001800₁₆ = 10246 144, including subcarriers 5123 584 and 10246 144, are included in the set.

...

Table 12-23 – PSD descriptor

Octet	Content of field
1	Number of subcarriers (or breakpoints) being described
2- <u>45</u>	Bits 0- <u>115</u> : Index of first subcarrier being described Bits <u>1216-2331</u> : PSD level in steps of 0.1 dB with an offset of -140 dBm/Hz
<u>56-79</u> (if applicable)	Bits 0- <u>115</u> : Index of second subcarrier being described Bits <u>1216-2331</u> : PSD level in steps of 0.1 dB with an offset of -140 dBm/Hz
etc.	etc.

The first octet of the descriptor shall contain the number of breakpoints being specified. This number can be zero. In that case, there shall be no additional octets in the descriptor. If the number of breakpoints is not equal to zero, each group of threefour consecutive octets shall describe one breakpoint as a PSD value at a certain subcarrier index.

The first 1216 bits (0-115) in the group of three octets shall contain the index of the subcarrier. The last 1216 bits (1216-2331) shall contain the PSD level. The PSD level shall be an integer multiple of 0.1 dB with an offset of -140 dBm/Hz. For example a field value of 32040003201800₁₆ means a PSD of $320_{16} \times 0.1 - 140 = -60$ dBm/Hz on subcarrier index 4001800₁₆ = 10246 144. The PSD level of intermediate unspecified subcarriers shall be obtained using a linear interpolation between the given PSD points (in dBm/Hz) with the frequency axis expressed in a linear scale. The subcarrier indices of the specified breakpoints may be either determined by the CO-MIB or vendor discretionary.

...

Field #13 "Downstream transmit window length (β_{ds})" shall contain the length of the downstream transmit window, (β_{ds}), expressed in multiples of 2 samples at the downstream sampling rate

corresponding to the IDFT size communicated during the ITU-T G.994.1 handshake phase. The value shall be coded as an 8-bit integer.

NOTE - The phrase "expressed in multiples of 2" means that the actual value used in the transceiver is 2 times the value represented in the field.

Field #14 "Downstream cyclic prefix" shall contain the length of the downstream cyclic prefix expressed in multiples of 2 samples at the downstream sampling rate corresponding to the IDFT size communicated during the ITU-T G.994.1 handshake phase. The value shall be coded as a 16-bit integer.

Field #15 "Initial value of timing advance" indicates the initial timing advance, and shall be expressed either in multiples of 2 samples if profile 35b is used with extended IDFT Size, or otherwise, in samples at the upstream sampling rate corresponding to the IDFT size communicated during the ITU-T G.994.1 handshake phase. The value shall be encoded in a 16-bit field using twos complement format. The special value of $7FFF_{16}$ indicates that the VTU-R shall select the initial setting of the timing advance.

...

12.3.3.2.1.2 O-UPDATE

...

Field #4 "Highest allowed upstream subcarrier" contains the index of the highest frequency upstream subcarrier that is allowed to be used by the VTU-R. The format shall be a 16-bit value. The subcarrier index shall be described as +213 bits. The fourthree MSBs of the field shall be set to ZERO. The VTU-R shall not allocate power to subcarriers above the highest allowed upstream subcarrier.

Field #5 "Lowest allowed upstream subcarrier" contains the index of the lowest-frequency upstream subcarrier that is allowed to be used by the VTU-R. The format shall be a 16-bit value. The subcarrier index shall be described as +213 bits. The fourthree MSBs of the field shall be set to ZERO. The VTU-R shall not allocate power to subcarriers below the lowest allowed upstream subcarrier.

...

Field #7 "Timing advance correction" contains the timing advance correction with respect to the currently used timing advance expressed either in multiples of 2 samples if profile 35b is used with extended IDFT Size, or otherwise, in samples at the upstream sampling rate corresponding to the IDFT size communicated during the ITU-T G.994.1 handshake phase. The value shall be encoded in a 16-bit field using twos complement format. Positive values shall indicate that the transmitted symbol will be advanced more with respect to the received symbol.

...

12.3.3.2.1.3 O-PRM

...

Field #5 "Downstream cyclic prefix length" contains the value of L_{CP} that shall be applied in the downstream direction starting from the beginning of the training phase. The value shall be expressed in multiples of 2 samples of the downstream sampling rate corresponding to the IDFT size communicated in Field #7. The format shall be the same as for Field #14 of the O-SIGNATURE message (Table 12-21).

Field #6 "Downstream transmit window length (β_{ds})" contains the length of the transmit window that shall be used in the downstream direction starting from the beginning of the training phase. The value shall be expressed in multiples of 2 samples of the downstream sampling rate corresponding to the

IDFT size communicated in Field #7. The format shall be the same as for Field #13 of the O-SIGNATURE message (Table 12-21).

Field #7 "VTU-O IDFT size" indicates the updated size of the IDFT at the VTU-O that shall be used in the downstream direction starting from the beginning of the training phase. This value may be different from the initial value that was exchanged during the ITU-T G.994.1 handshake phase. The value shall be expressed as the IDFT size $2N_{ds}$. The format shall be an 8-bit field coded as $\log_2(2N_{ds})$ with valid values from 7 to ~~13~~14.

...

Table 12-31 – Log_{tssi} descriptor

Octet	Content of field
1	Number of breakpoints (subcarriers) to be described
2-54	Bits 0- 115 : Subcarrier index of the first breakpoint Bits 1216-2331 : \log_{tssi} value of the first breakpoint in steps of 0.1 dB
56-79 (if applicable)	Bits 0- 115 : Subcarrier index of the second breakpoint Bits 1216-2331 : \log_{tssi} value of the second breakpoint in steps of 0.1 dB
etc.	etc.

The first octet of the descriptor shall contain the number of breakpoints being specified. This number can be zero. In that case, there shall be no further octets in the descriptor, and the field shall be interpreted as all $\log_{tssi} = 0$ for all transmitted subcarriers. If the number of breakpoints is not equal to zero, each group of ~~three~~four consecutive octets shall describe one breakpoint as a \log_{tssi} value (see clause 10.3.4.3) at a certain subcarrier index. The $tssi$ values shall be determined by the transmitter such that, with combined frequency domain and time domain spectrum shaping, the downstream PSD at the U interface during the training phase and subsequent initialization phases shall be identical to the value MREFPSDs.

The first ~~1216~~ bits (0-~~115~~) in the group of ~~three~~four octets shall contain the index of the subcarrier. The last ~~1216~~ bits (~~1216-2331~~) shall contain the \log_{tssi} value of the subcarrier in dB calculated as specified in clause 10.3.4.3, such that the maximum \log_{tssi} value across all breakpoints shall be 0 dB. Each \log_{tssi} value shall be an integer multiple of -0.1 dB. The receiver shall obtain the \log_{tssi} values for unspecified subcarriers using a linear interpolation between the \log_{tssi} values of the assigned breakpoints as specified in clause 10.3.4.3.

...

12.3.3.2.2.1 R-MSG 1

...

Table 12-33 – Tone descriptor

Octet	Content of field
1	Number of tones
2-45	Bits 0- 115 : index of tone 1 Bits 1216-2331 : index of tone 2
56-79 (if applicable)	Bits 0- 115 : index of tone 3 Bits 1216-2331 : index of tone 4
etc.	etc.

The first octet of the tone descriptor shall contain the number of pilot tones selected by the VTU-R. If this number is zero, there shall be no further octets in the descriptor. If the number of tones is not equal to zero, each group of ~~three~~four consecutive octets in the descriptor shall describe the location of two pilot tones.

The first ~~12~~16 bits (0-~~11~~15) and the last ~~12~~16 bits (~~12~~16-~~23~~31) in each group of ~~three~~four octets shall contain the indices of two tones. For example, a field value ~~40020018000E00~~₁₆ means tone ~~2000E00~~₁₆ = ~~5123 584~~ and tone ~~4001800~~₁₆ = ~~10246 144~~. If the number of pilot tones is odd, the last ~~12~~16 bits in the field shall be set to ZERO.

Field #6 "Timing advance" indicates the timing advance selected by the VTU-R (which is either the initial value conveyed by the O-SIGNATURE message or a vendor-discretionary setting if no initial value was set by the VTU-O). It shall be expressed either in multiples of 2 samples if profile 35b is used with extended IDFT Size, or otherwise, in samples at the upstream sampling rate corresponding to the IDFT size communicated during the ITU-T G.994.1 handshake phase. The value shall be encoded in a 16-bit field using twos complement format.

...

Field #8 "Upstream transmit window length (β_{us})" contains the length of the transmit window that shall be used in the upstream direction during the channel discovery phase. The value shall be expressed either in multiples of 2 samples if profile 35b is used with extended IDFT Size, or otherwise, in ~~the~~ samples of the upstream sampling rate corresponding to the IDFT size communicated during the ITU-T G.994.1 handshake phase. The format shall be the same as for Field #13 of the O-SIGNATURE message (Table 12-21).

Field #9 "Upstream cyclic prefix length" contains the length of the upstream cyclic prefix expressed either in multiples of 2 samples if profile 35b is used with extended IDFT Size, or otherwise, in samples of the upstream sampling rate corresponding to the IDFT size communicated during the ITU-T G.994.1 handshake phase. The value shall be coded as a 16-bit unsigned integer.

...

12.3.3.2.2.3 R-PRM

...

Field #4 "Upstream cyclic prefix length" contains the value of the cyclic prefix that shall be applied in the upstream direction starting from the beginning of the training phase. The value shall be expressed either in multiples of 2 samples if profile 35b is used with extended IDFT Size, or otherwise, in samples of the upstream sampling rate corresponding to the IDFT size communicated in Field #6. The format of the selected cyclic prefix length shall be the same as for Field #14 of the O-SIGNATURE message (Table 12-21).

NOTE 1 - Profile 35b being used with extended IDFT Size is equivalent with Field #6 having value 14.

NOTE 2 – The value of the CE length used in the calculation of the upstream cyclic prefix length is the value communicated in O-PRM, not the one sent in R-UPDATE.

Field #5 "Upstream transmit window length (β_{us})" contains the length of the transmit window that shall be used in the upstream direction starting from the beginning of the training phase. The value shall be expressed either in multiples of 2 samples if profile 35b is used with extended IDFT Size, or otherwise, in samples of the upstream sampling rate corresponding to the IDFT size communicated in Field #6. The format shall be the same as for Field #13 of the O-SIGNATURE message (Table 12-21).

Field #6 "VTU-R IDFT size" communicates the IDFT size, $2N_{us}$, that shall be used by the VTU-R starting from the beginning of the training phase. The format shall be an 8-bit field coded as

$\log_2(2N_{us})$, with valid values from 6 to ~~13~~14. This value may be different from the initial value that was exchanged during the ITU-T G.994.1 handshake phase.

...

12.3.4.2.1.1 O-TA_UPDATE

...

Field #2 "Timing advance correction" defines the timing advance correction that shall be used with respect to the current timing advance. It shall be expressed either in multiples of 2 samples if profile 35b is used with extended IDFT Size, or otherwise, in samples at the upstream sampling rate corresponding to the IDFT size communicated in Field #6 of R-PRM. The value shall be encoded in a 16-bit field using twos complement format. Positive values shall indicate that the transmitted symbol will be advanced more with respect to the received symbol.

...

12.3.4.2.2.1 R-TA_UPDATE

...

Field #2 "Current timing advance" gives the timing advance currently being used by the VTU-R. The field is expressed either in multiples of 2 samples if profile 35b is used with extended IDFT size, or otherwise, in samples at the upstream sampling rate corresponding to the IDFT size communicated in Field #6 of R-PRM. The value shall be encoded in a 16-bit field using twos complement format.

Field #3 "Timing advance correction" indicates the timing advance correction, with respect to the current timing advance, preferred by the VTU-R either in multiples of 2 samples if profile 35b is used with extended IDFT size, or otherwise, in samples at the upstream sampling rate corresponding to the IDFT size communicated in Field #6 of R-PRM. The value shall be encoded in a 16-bit field using twos complement format. Positive values shall indicate that the transmitted symbol will be advanced more with respect to the received symbol.

Field #4 "Maximum value of timing advance" indicates the maximum value of timing advance that the VTU-R can accommodate either in multiples of 2 samples if profile 35b is used with extended IDFT size, or otherwise, in samples at the current upstream sampling rate corresponding to the IDFT size communicated in Field #6 of R-PRM. The value shall be encoded in a 16-bit field using twos complement format.

...

12.3.5.2.1.3 O-PMS

...

Table 12-57 – Latency path descriptor

Octet	Field	Format	Description
1	T	1 byte	The number of MDFs in an OH subframe for the latency path; $T = k \times M$, where k is an integer. The value of T shall not exceed 64.
2	G	1 byte	The total number of overhead octets in an OH subframe for the latency path; $1 \leq G \leq 32$.

Table 12-57 – Latency path descriptor

Octet	Field	Format	Description
3	F	1 byte	Number of OH frames in the OH superframe for the latency path. $1 \leq F \leq 255$.
4	M	1 byte	The number of MDFs in an RS codeword for the latency path. Only the values 1, 2, 4, 8, 16 are allowable.
5, 6 and 67	L	23 bytes	Contains the value of L for the latency path.
78	R	1 byte	Contains the value of R for the latency path.
89	I	1 byte	Contains the value of I for the latency path.
910 and 1011	D	2 bytes	Interleaver depth D for the latency path.

Table 12-58 – ROC descriptor

Octet	Field	Format	Description
1	T	1 byte	The number of MDFs in an OH subframe of the ROC. $T = k \times M$, where k is an integer. The value of T shall not exceed 64.
2	G	1 byte	The total number of overhead octets in an OH subframe of the ROC; The valid values of G are $1 \leq G \leq 32$.
3	F	1 byte	Number of OH frames in the OH superframe for the ROC. The value of F shall be 1.
4	M	1 byte	The number of MDFs in an RS codeword for the ROC. The valid values of M are 1, 2, 4, 8 and 16.
5, 6 and 67	L	23 bytes	Contains the value of L for the ROC. The valid values of L are from 8 to 128 in multiples of 8.
78	R	1 byte	Contains the value of R for the ROC. The value of R shall be 16.
89	I	1 byte	Contains the value of I for the ROC. I shall be set to $I = M \times (G/T) + R$. The valid values of I are $32 \leq I \leq 66$.
910 and 1011	D	2 bytes	Interleaver depth D for the ROC. The valid values of D are $1 \leq D \leq 20$.

...

12.3.5.2.1.4 O-PMD

...

Table 12-59 – Description of message O-PMD

	Field name	Format
1	Message descriptor	Message code
2	Trellis	1 byte
3	Bits and gains table	$2 \times N_{SC_{us}}$ bytes
4	Tone ordering table	$34 \times \lceil N_{SC_{us}}/2 \rceil$ bytes coded as follows: <ul style="list-style-type: none"> • Bits 0-15: t_{2n-1} • Bits 16-31: t_{2n}
5	Initialization status	1 byte
6	ITU-T G.998.4 parameter field	Variable length
7	ITU-T G.993.5 parameter field	Variable length
NOTE – The $\lceil x \rceil$ notation represents rounding to the nearest greater integer.		

...

Field #4 "Tone ordering table" contains the tone ordering table t for the upstream direction. The tone ordering table contains the order in which the subcarriers shall be assigned bits in the upstream direction. The table shall include all subcarriers of the MEDLEY_{us} set and only these subcarriers. Each subcarrier index shall be represented as a 16-bit value. Pairs of subcarrier indices shall be mapped to a field of 34 bytes as shown in Table 12-59. For example, if the value of the n^{th} field is 40020018001000_{16} , $t_{2n-1} = 2001000_{16} = 5124\ 096$ and $t_{2n} = 4001800_{16} = 10246\ 144$. If the number of subcarriers in the MEDLEY_{us} set is odd, the last 16 bits of the field shall be set to ZERO (and ignored by the receiver). The value of the first index sent shall be equal to the index of the first entry in the tone ordering table (t_1 , see clause 10.3.1). The remaining indices shall be sent in increasing order of the tone ordering table t entries ($t_2, t_3, \dots t_{N_{SC_{us}}}$).

...

12.3.5.2.2.4 R-PMD

...

Table 12-65 – Description of message R-PMD

	Field name	Format
1	Message descriptor	Message code
2	Trellis	1 byte
3	Bits and gains table	$2 \times N_{SC_{ds}}$ bytes
4	Tone ordering table	$34 \times \lceil N_{SC_{ds}}/2 \rceil$ bytes coded as follows: <ul style="list-style-type: none"> • Bits 0-15: t_{2n-1} • Bits 16-31: t_{2n}
5	Showtime pilot tones	Tone descriptor
6	Initialization status	1 byte
7	ITU-T G.998.4 parameter field	Variable length
8	ITU-T G.993.5 parameter field	Variable length
NOTE – The $\lceil x \rceil$ notation represents rounding to the nearest greater integer.		

...

Field #4 "Tone ordering table" contains the tone ordering table t for the downstream direction. The tone ordering table contains the order in which the subcarriers shall be assigned bits in the downstream direction. The table shall include all subcarriers of the MEDLEYds set and only these subcarriers. Each subcarrier index shall be represented as a ~~42~~16-bit value. Pairs of subcarrier indices shall be mapped to a field of ~~34~~ bytes as shown in Table 12-65. For example, if the value of the n^{th} field is ~~40020018001000~~₁₆, $t_{2n-1} = \del{2001000}_{16} = \del{5124\ 096} and $t_{2n} = \del{4001800}_{16} = \del{1\ 0246\ 144}. If the number of subcarriers in the MEDLEYds set is odd, the last ~~42~~16 bits of the field shall be set to ZERO (and ignored by the receiver). The value of the first index sent shall be equal to the index of the first entry in the tone ordering table (t_1 , see clause 10.3.1). The remaining indices shall be sent in increasing order of the tone ordering table t entries ($t_2, t_3, \dots t_{NSCds}$).}$}$

...

Q.7 Additional changes to ITU-T G.998.4 for operation according to profile 35b

NOTE – This clause uses revision marks where changes are made relative to the approved text. Unchanged text is replaced by ellipsis (...).

The U reference point specification for operation according to profile 35b shall be the same as specified in [ITU-T G.998.4] for operation with ITU-T G.993.2, with differences listed in this clause.

C.3.2 On-line reconfiguration (OLR) commands and responses

...

Table C.11 – OLR commands sent by the initiating VTUName

	Length (octets)	Octet number	Content	Support
Request Type 5 (SRA/ ITU-T G.998.4)	14+4 N_f ($N_f \leq 128$)	2	08 ₁₆	Optional Mandatory
		3- 4 5	two three octets containing the new value for L_I	
		5 6	one octet containing the new value for B_{I0}	
		6 7	one octet containing the new value for M_I	
		7 8	one octet containing the new value for R_I	
		8 9	one octet containing the new value for Q	
		9 10	one octet containing the new value for V	
		10 11	one octet containing the new value for Q_{ix}	
		11 12	one octet containing the new value for lb	
		12 13 – 13 14	2 octets for the number of subcarriers N_f to be modified	
		13 15 – 13 14+4 N_f	4 N_f octets describing the subcarrier parameter field for each subcarrier	

Table C.11 – OLR commands sent by the initiating VTUName

	Length (octets)	Octet number	Content	Support	
		1 <u>15</u> +4 N_f	1 octet for Segment Code (SC)		
Request Type 6 (SOS/ITU-T G.998.4)	$N_{TG}/2+12$	2	09 ₁₆	Optional	
		3	Message ID		
		4 to $N_{TG}/2+3$	$\Delta b(2)$		$\Delta b(1)$
			$\Delta b(4)$		$\Delta b(3)$
			...		
			$\Delta b(N_{TG})$		$\Delta b(N_{TG} - 1)$
		$N_{TG}/2+4$ to $N_{TG}/2+56$	two <u>three</u> octets containing the new value for L_I		
		$N_{TG}/2+67$	one octet containing the new value for B_{I0}		
		$N_{TG}/2+78$	one octet containing the new value for M_I		
		$N_{TG}/2+89$	one octet containing the new value for R_I		
		$N_{TG}/2+910$	one octet containing the new value for Q		
		$N_{TG}/2+1011$	one octet containing the new value for V		
		$N_{TG}/2+1112$	one octet containing the new value for Q_{tx}		
		$N_{TG}/2+1213$	one octet containing the new value for lb		

...

Annex R

This annex is intentionally left blank.

Annex S

This annex is intentionally left blank.

Annex T

This annex is intentionally left blank.

Annex U

This annex is intentionally left blank.

Annex V

This annex is intentionally left blank.

Annex W

This annex is intentionally left blank.

Annex X

ITU-T G.993.5-friendly ITU-T G.993.2 operation in the downstream direction

(This annex forms an integral part of this Recommendation.)

This annex provides the necessary and sufficient additional requirements for ITU-T G.993.2 operation to allow cancellation of the downstream crosstalk from lines with ITU-T G.993.2 Annex X VTU-Rs into lines with ITU-T G.993.5 VTU-Rs (both connected to ITU-T G.993.5-capable VTU-Os).

This includes:

- Requirements for the ITU-T G.993.2 Annex X VTU-O downstream transmit signals.
- Requirements for the ITU-T G.993.2 Annex X VTU-R downstream receiver to be immune to the ITU-T G.993.2 Annex X VTU-O downstream transmit signals sent by the VTU-O during Initialization and Showtime. The VTU-R shall be immune to the VTU-O sending pilot sequences on the probe tones (as defined in [ITU-T G.993.5]) of the sync symbols during showtime.

A VTU-O supporting operation according to this annex shall also support operation according to [ITU-T G.993.5].

This annex reflects changes to the main body of this Recommendation to allow ITU-T G.993.5-friendly operation of ITU-T G.993.2 in the downstream direction. The clauses below indicate changes to specific clauses of this Recommendation.

NOTE – Simultaneous initialization of a line operating per this annex and a line operating per [ITU-T G.993.5] or per ITU-T G.993.2 Annex O only supports downstream vectoring.

X.1 Power management commands and responses (clause 11.2.3.9)

The same power management commands and responses shall be used as defined in clause 11.2.3.9. The orderly shutdown procedures described in clauses 11.2.3.9.1 and 11.2.3.9.2 shall be modified as defined in this clause.

X.1.1 L3 Request by VTU-R (replaces clause 11.2.3.9.1)

Upon receipt of the L3 Request command, the responding VTU-O shall send either the Grant or Reject response. The proposed link state shall be formatted as 03₁₆ for the L3 link state. If any other link state is received, the Reject response shall be sent with the reason code 02₁₆.

The VTU-O may reject a request to move to link state L3 using reason code 01₁₆ because it is temporarily busy, or reject it using code 03₁₆ because it has local knowledge that the L3 state is not desired at this time.

If the VTU-R receives the Grant response, the VTU-R shall transmit zero power on all subcarriers. The VTU-R shall make no action causing changes to the characteristics of the transmission path. When the VTU-O observes the stopped transmission, it shall also stop transmitting. When the VTU-R observes the stopped transmission, it may perform at its own discretion functions that change characteristics of the transmission path.

X.1.2 L3 Request by VTU-O (replaces clause 11.2.3.9.2)

Upon receipt of the L3 Request command, the responding VTU-R shall send either the Grant or Reject response. The proposed link state shall be formatted as 03₁₆ for the L3 link state. If any other link state is received, the Reject response shall be sent with the reason code 02₁₆.

The VTU-R may reject a request to move to link state L3 using reason code 01₁₆ because it is temporarily too busy, or reject it using code 03₁₆ because it has local knowledge that the L3 state is not desired at this time.

If the VTU-O receives the Grant response, the VTU-O shall transmit zero power on all subcarriers. The VTU-O shall make no actions causing changes to the characteristics of the transmission path. When the VTU-R observes the stopped transmission, it shall also stop transmitting. When the VTU-O observes the stopped transmission, it may perform at its own discretion functions that change characteristics of the transmission path.

X.2 Initialization procedure (supplements clause 12.3)

If and only if the ITU-T G.994.1 VTU-O MS message or VTU-R MS message the NPar(2) bit "ITU-T G.993.5-friendly ITU-T G.993.2 operation in the downstream direction" is set to ONE, the VTU-O shall use a modified ITU-T G.993.2 initialization procedure, as defined in this annex.

This initialization procedure is identical to an ITU-T G.993.2 initialization procedure, except for the channel discovery phase and the training phase.

As applicable to the VTU-O, this initialization procedure defines two new signals to be transmitted.

As applicable to the VTU-R, this initialization procedure requires these two new signals to be ignored.

X.2.1 ITU-T G.994.1 handshake phase

X.2.1.1 Handshake – VTU-O

X.2.1.1.1 CL messages (supplements clause 12.3.2.1.1)

Table 12-7 shall be extended with Table X.1 as follows:

Table X.1 – VTU-O CL message NPar(2) bit definitions

ITU-T G.994.1 NPar(2) bit	Definition of NPar(2) bit
ITU-T G.993.5-friendly ITU-T G.993.2 operation in the downstream direction	<p>This bit shall be set to ONE, if and only if the VTU-O supports Annex X and Annex X is allowed via the CO-MIB (i.e., VECTORMODE_ENABLE bit 1 is set to 1, see clause 7.3.1.13.9 of [ITU-T G.997.1]).</p> <p>If set to ONE, indicates the capability of the VTU-O to comply with all requirements of this annex, including:</p> <ul style="list-style-type: none"> • to send O-P-VECTOR-1 (as defined in [ITU-T G.993.5]) during initialization after O-P-QUIET and before O-P-CHANNEL DISCOVERY 1, and • to send O-P-VECTOR-1-1 (as defined in [ITU-T G.993.5]) during initialization after O-P-SYNCHRO 3 and before O-P-TRAINING 1, and • to send pilot sequences on the probe tones (as defined in [ITU-T G.993.5]) of the sync symbols during showtime. <p>If set to ONE, and the CO-MIB VECTORMODE_ENABLE bit 3 is set to 1 (see clause 7.3.1.13.9 of [ITU-T G.997.1]), then the ITU-T G.993.5 SPar(2) bit shall also be set to ONE.</p>

X.2.1.1.2 MS messages (supplements clause 12.3.2.1.2)

Table 12-10 shall be extended with Table X.2 as follows:

Table X.2 – VTU-O MS message NPar(2) bit definitions

ITU-T G.994.1 NPar(2) bit	Definition of NPar(2) bit
ITU-T G.993.5-friendly ITU-T G.993.2 operation in the downstream direction	<p>Set to ONE if and only if both the last previous CLR and the last previous CL messages have set this bit to ONE. If set to ONE, indicates that both the VTU-O and VTU-R shall operate in compliance with all requirements of this annex, including that the VTU-O shall:</p> <ul style="list-style-type: none"> • send O-P-VECTOR-1 (as defined in [ITU-T G.993.5]) during initialization after O-P-QUIET and before O-P-CHANNEL DISCOVERY 1, and • send O-P-VECTOR-1-1 (as defined in [ITU-T G.993.5]) during initialization after O-P-SYNCHRO 3 and before O-P-TRAINING 1, and • send pilot sequences on the probe tones (as defined in [ITU-T G.993.5]) of the sync symbols during showtime. <p>NOTE – If this bit is set to ONE, bits "Full ITU-T G.993.5-friendly ITU-T G.993.2 operation" and "ITU-T G.993.5" are set to ZERO in the VTU-O MS message.</p>

X.2.1.2 Handshake – VTU-R

X.2.1.2.1 CLR messages (supplements clause 12.3.2.2.1)

Table 12-13 shall be extended with Table X.3 as follows:

Table X.3 – VTU-R CLR message NPar(2) bit definitions

ITU-T G.994.1 NPar(2) bit	Definition of NPar(2) bit
ITU-T G.993.5-friendly ITU-T G.993.2 operation in the downstream direction	<p>Set to ONE if the VTU-R is compliant with all requirements of this annex, including being immune to a VTU-O</p> <ul style="list-style-type: none"> • sending O-P-VECTOR-1 (as defined in [ITU-T G.993.5]) after O-P-QUIET and before O-P-CHANNEL DISCOVERY 1, and • sending O-P-VECTOR-1-1 (as defined in [ITU-T G.993.5]) during initialization after O-P-SYNCHRO 3 and before O-P-TRAINING 1, and • sending pilot sequences on the probe tones (as defined in [ITU-T G.993.5]) of the sync symbols during showtime. <p>If set to ONE, the ITU-T G.993.5 SPar(2) bit shall be set to ZERO (see Note).</p>
NOTE – A VTU-R that has ITU-T G.993.5 capability enabled sets this NPar(2) bit to 0.	

X.2.1.2.2 MS messages (supplements clause 12.3.2.2.2)

Table 12-16 shall be extended with Table X.4 as follows:

Table X.4 – VTU-R MS message NPar(2) bit definitions

ITU-T G.994.1 NPar(2) bit	Definition of NPar(2) bit
ITU-T G.993.5-friendly ITU-T G.993.2 operation in the downstream direction	<p>Set to ONE if and only if both the last previous CLR and the last previous CL message have set this bit to ONE. If set to ONE, indicates that both the VTU-O and VTU-R shall operate in compliance with all requirements of this annex, including that the VTU-O shall:</p> <ul style="list-style-type: none">• send O-P-VECTOR-1 (as defined in [ITU-T G.993.5]) after O-P-QUIET and before O-P-CHANNEL DISCOVERY 1, and• send O-P-VECTOR-1-1 (as defined in [ITU-T G.993.5]) during initialization after O-P-SYNCHRO 3 and before O-P-TRAINING 1, and• send pilot sequences on the probe tones (as defined in [ITU-T G.993.5]) of the sync symbols during showtime. <p>NOTE – If this bit is set to ONE, bits "Full ITU-T G.993.5-friendly ITU-T G.993.2 operation" and "ITU-T G.993.5" are set to ZERO in the VTU-R MS message.</p>

X.2.2 Channel discovery phase

X.2.2.1 Overview (supplements clause 12.3.3.1)

Figure X.1 replaces Figure 12-6. Figure X.1 highlights the signals added and the signals/messages modified in the ITU-T G.993.2 Channel Discovery phase for operation according to this annex. Non-highlighted signals and messages shall be as defined in the main body of this Recommendation.

The VTU-O shall initiate the start of the channel discovery phase with O-P-QUIET 1 as defined in clause 12.3.3.1.

When in the ITU-T G.994.1 VTU-O MS message or VTU-R MS message the NPar(2) bit "ITU-T G.993.5-friendly ITU-T G.993.2 operation in the downstream direction" is set to ONE, the VTU-O shall use a modified ITU-T G.993.2 initialization procedure, by insertion of ITU-T G.993.5 O-P-VECTOR 1 of duration no longer than $1\ 024 \times 257$ symbols after O-P-QUIET 1.

NOTE – As applicable to the VTU-O, this channel discovery phase is identical to an ITU-T G.993.5 channel discovery phase with all segments x-P-VECTOR y-z set to zero length, except for O-P-VECTOR 1.

After completing the O-P-VECTOR 1 stage, the VTU-O shall start transmitting O-P-CHANNEL DISCOVERY 1 and proceed as defined in clause 12.3.3.1.

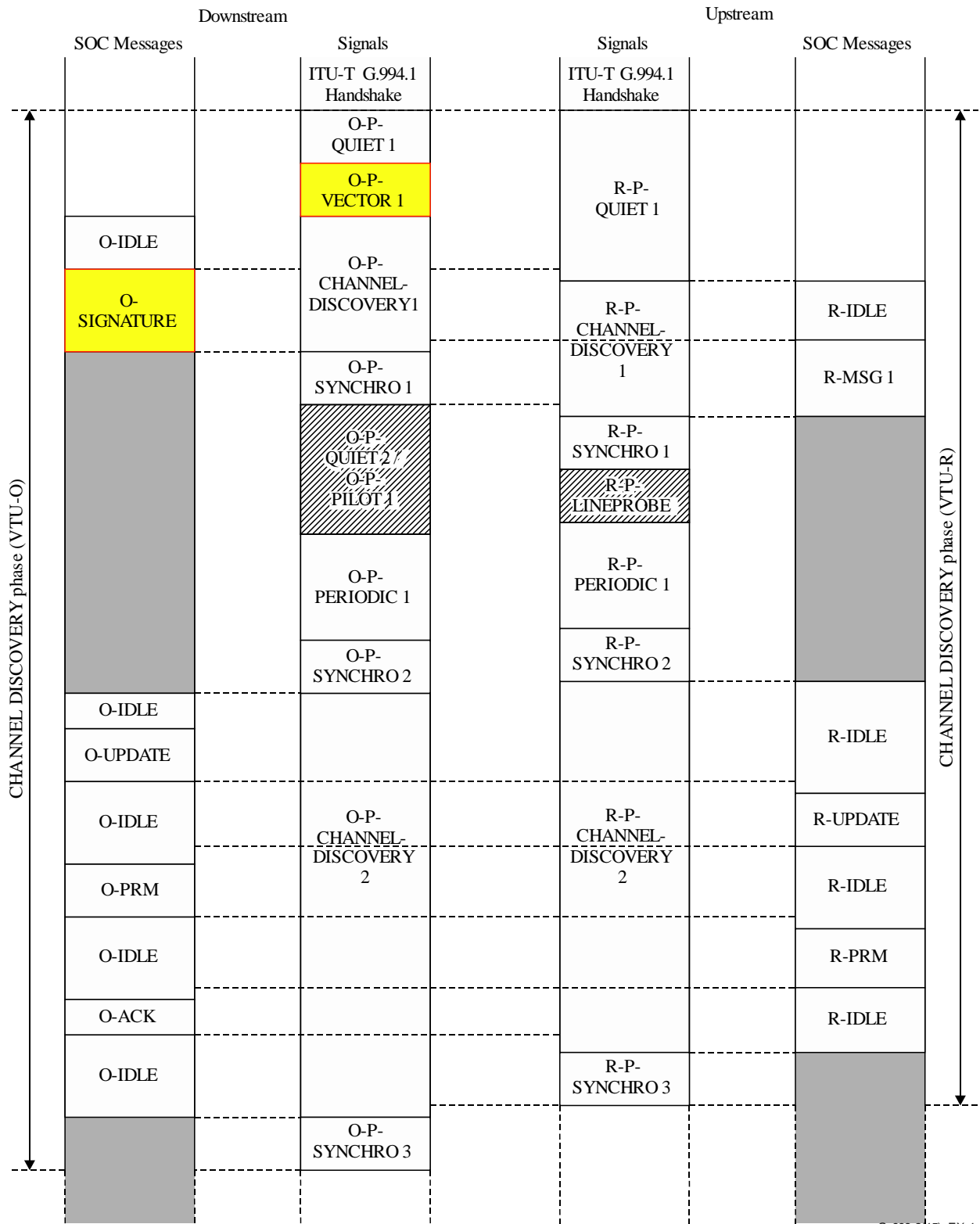

G.993.2(15)_FX.1

Figure X.1 – Timing diagram for the stages of the channel discovery phase

Table 12-19 shall be extended with Table X.5 as follows:

Table X.5 – VTU-O signals and SOC messages in the channel discovery phase

Signal	Signal type	Signal duration in DMT symbols with CE	SOC messages	SOC state
O-P-VECTOR 1	ITU-T G.993.5	4×257 to $1\,024 \times 257$	None	Inactive

X.2.2.1a SOC message exchange during the channel discovery phase (supplements clause 12.3.3.2)

X.2.2.1a.1 VTU-O messages sent during the channel discovery phase (supplements clause 12.3.3.2.1)

X.2.2.1a.1.1 O-SIGNATURE (supplements clause 12.3.3.2.1.1)

Table 12-21 field #23 shall be replaced with Table X.5a field #23 as follows:

Table X.5a – Description of message O-SIGNATURE

	Field name	Format
23	O-P-VECTOR 1-1 maximum duration	1 byte

Field #23 "O-P-VECTOR 1-1 maximum duration" field indicates the maximum duration of the O-P-VECTOR 1-1 signal, as defined in Table X.6. The three LSBs shall represent the value of n in the range 0 to 7 and the five MSBs shall be set to 0.

X.2.2.2 Signals transmitted during the channel discovery phase (supplements clause 12.3.3.3)

O-P-VECTOR 1 shall comply with the general requirements for signals transmitted during the channel discovery phase.

X.2.2.2.1 Signals transmitted by the VTU-O

X.2.2.2.1.1 O-P-VECTOR 1-1 (supplements clause 12.3.4.3.1 preceding clause 12.3.3.3.1.1)

O-P-VECTOR 1-1 shall be as defined in [ITU-T G.993.5].

X.2.2.2.1.2 O-P-VECTOR 1 (supplements clause 12.3.3.3.1 between clauses 12.3.3.3.1.1 and 12.3.3.3.1.2)

O-P-VECTOR 1 shall be as defined in [ITU-T G.993.5].

X.2.2.2.1.3 O-P-SYNCHRO 3 (replaces clause 12.3.3.3.1.9)

O-P-SYNCHRO 3 is a signal that provides an exact time marker for transitions from O-P-CHANNEL DISCOVERY 2 to O-P-VECTOR 1-1 (training phase).

O-P-SYNCHRO 3 shall be identical to O-P-SYNCHRO 1.

X.2.3 Training phase

X.2.3.1 Overview (supplements clause 12.3.4.1)

Figure X.2 replaces Figure 12-8. Figure X.2 highlights the signals added and the signals/messages modified in the ITU-T G.993.2 training phase for operation according to this annex. Non-highlighted signals and messages shall be as defined in the main body of this Recommendation.

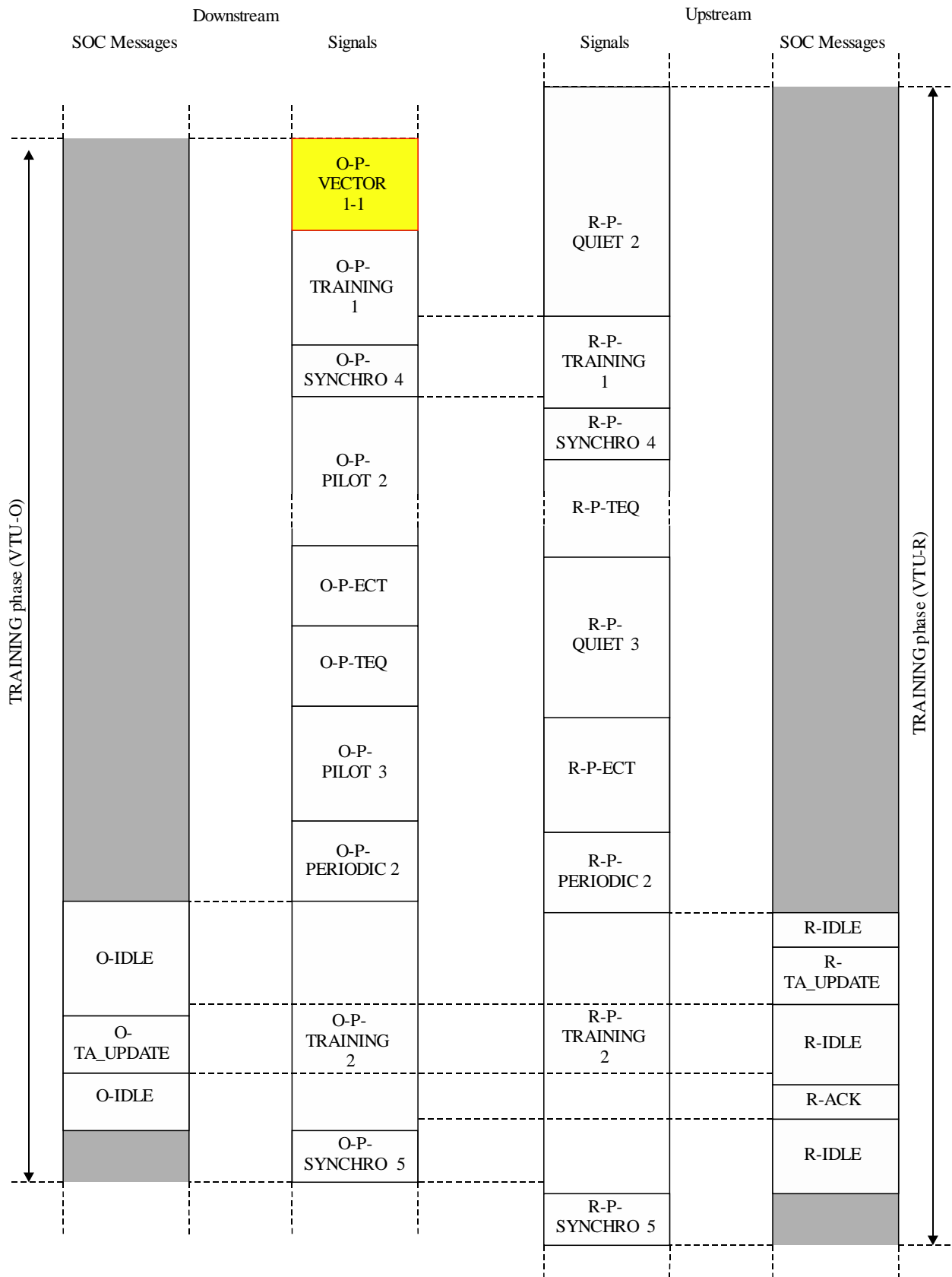

G.993.2(15)_FX.2

Figure X.2 – Timing diagram for the stages of the training phase

When in the ITU-T G.994.1 VTU-O MS message or VTU-R MS message the NPar(2) bit "ITU-T G.993.5-friendly ITU-T G.993.2 operation in the downstream direction" is set to ONE, at the start of the training phase, the VTU-O shall transmit O-P-VECTOR 1-1, and the VTU-R shall be silent (R-P-QUIET 2). O-P-VECTOR 1-1 shall be followed by O-P-TRAINING 1, while the VTU-R is still silent (R-P-QUIET 2). The remainder of the initialization procedure shall be as defined in clause 12.3.4.1.

NOTE – As applicable to the VTU-O, this training phase is identical to an ITU-T G.993.5 training phase with all segments x-P-VECTOR y-z set to zero length except for O-P-VECTOR 1-1.

Table 12-39 shall be extended with Table X.6 as follows:

Table X.6 – VTU-O signals and SOC messages in the training phase

Signal	Signal type	Signal duration in DMT symbols with CE	SOC messages	SOC state
O-P-VECTOR 1-1	ITU-T G.993.5	4×257 to $(n+1) \times 1\,024 \times 257$, with $n=0\dots7$ (see Note)	None	Inactive

NOTE – The value of n is communicated to the VTU-R in O-SIGNATURE message during the channel discovery phase (see Table X.5a).

X.2.3.2 Signals transmitted during the training phase (supplements clause 12.3.4.3)

O-P-VECTOR 1-1 shall comply with the general requirements for signals transmitted in the training phase.

X.2.3.2.1 Signals transmitted by the VTU-O

Annex Y

Full ITU-T G.993.5-friendly ITU-T G.993.2 operation

(This annex forms an integral part of this Recommendation.)

This annex provides the necessary and sufficient additional requirements for ITU-T G.993.2 operation to allow cancellation of the downstream and upstream crosstalk from lines with ITU-T G.993.2 Annex Y VTU-Rs into lines with ITU-T G.993.5 VTU-Rs (both connected to ITU-T G.993.5-capable VTU-Os that also support upstream vectoring).

NOTE 1 – These requirements also allow cancellation of the upstream crosstalk from lines with ITU-T G.993.5 VTU-Rs into lines with ITU-T G.993.2 Annex Y VTU-Rs (both connected to ITU-T G.993.5-capable VTU-Os).

A VTU-O supporting operation according to this annex shall also support [ITU-T G.993.5] with support of upstream vectoring.

NOTE 2 – Indication of support of ITU-T G.993.5 upstream vectoring in the VTU-O CL message, together with indicating support of ITU-T G.993.2 Annex Y, does not imply a requirement for cancellation of upstream crosstalk from lines with ITU-T G.993.5 VTU-Rs into a line operating according to ITU-T G.993.2 Annex Y.

NOTE 3 – A VTU-R supporting operation according to this annex supports all functionality of ITU-T G.993.5 (including change of the upstream pilot sequence), except for the clipped error sample feedback during initialization (support of R-ERROR-FEEDBACK message is not required) and Showtime (support of the backchannel is not required).

This annex reflects changes to the main body of this Recommendation and [ITU-T G.993.5]. The clauses below indicate changes to specific clauses of Recommendation ITU-T G.993.2 and [ITU-T G.993.5].

Y.1 Initialization procedure (supplements clause 12.3)

If and only if the ITU-T G.994.1 VTU-O MS message or VTU-R MS message the NPar(2) bit "Full ITU-T G.993.5-friendly ITU-T G.993.2 operation" is set to ONE, the VTU-O and VTU-R shall use the a modified ITU-T G.993.5 initialization procedure, as defined in this annex. If, in addition, NPar(2) bit "Upstream FDPS in full ITU-T G.993.5-friendly ITU-T G.993.2 operation" is set to ONE, the VTU-O and VTU-R shall also support upstream frequency dependent pilot sequences (FDPS) as defined in ITU-T G.993.5.

This initialization procedure is identical to an ITU-T G.993.5 initialization procedure, except for the initialization messages R-MSG 1, O_TA-UPDATE, and O-PMS and for the initialization signal R-P-VECTOR 2 (during which the message R-ERROR-FEEDBACK is not transmitted).

Y.1.1 ITU-T G.994.1 Handshake phase

Y.1.1.1 Handshake – VTU-O

Y.1.1.1.1 CL messages (supplements clause 12.3.2.1.1 of ITU-T G.993.2)

Table 12-7 shall be extended with Table Y.1 as follows:

Table Y.1 – VTU-O CL message NPar(2) bit definitions

ITU-T G.994.1 NPar(2) bit	Definition of NPar(2) bit
Full ITU-T G.993.5-friendly ITU-T G.993.2 operation	<p>This bit shall be set to ONE, if and only if the VTU-O supports Annex Y and Annex Y is allowed via the CO-MIB (i.e., VECTORMODE_ENABLE bit 2 is set to 1, see clause 7.3.1.13.9 of [ITU-T G.997.1]).</p> <p>If set to ONE, indicates that the VTU-O supports compliance with this annex (full ITU-T G.993.5-friendly ITU-T G.993.2 operation).</p> <p>If set to ONE, and the CO-MIB VECTORMODE_ENABLE bit 3 is set to 1 (see clause 7.3.1.13.9 of [ITU-T G.997.1]), then both the ITU-T G.993.5 SPar(2) bit and the related "Upstream vectoring" NPar(3) bit shall also be set to ONE.</p>
Pilot sequence length multiple of 4 in full ITU-T G.993.5-friendly ITU-T G.993.2 operation	<p>If set to ONE, this bit indicates the VTU-O supports pilot sequence lengths that are a multiple of 4. If set to ZERO, this bit indicates the VTU-O only supports pilot sequence lengths that are a power of 2.</p> <p>If set to ONE, the "Full ITU-T G.993.5-friendly ITU-T G.993.2 operation" bit shall also be set to ONE.</p>
Upstream FDPS in full ITU-T G.993.5-friendly ITU-T G.993.2 operation	<p>If set to ONE, indicates that the VTU-O supports upstream FDPS as defined in ITU-T G.993.5 when in full ITU-T G.993.5-friendly ITU-T G.993.2 operation.</p> <p>If set to ONE, the "Full ITU-T G.993.5-friendly ITU-T G.993.2 operation" bit shall also be set to ONE.</p>

Y.1.1.1.2 MS messages (supplements clause 12.3.2.1.2 of ITU-T G.993.2)

Table 12-10 shall be extended with Table Y.2 as follows:

Table Y.2 – VTU-O MS message NPar(2) bit definitions

ITU-T G.994.1 NPar(2) bit	Definition of NPar(2) bit
Full ITU-T G.993.5-friendly ITU-T G.993.2 operation	<p>Set to ONE if and only if both the last previous CLR and the last previous CL messages have set this bit to ONE.</p> <p>If set to ONE, both the VTU-O and VTU-R shall operate as defined in this annex.</p> <p>NOTE – If set to ONE, the bit "ITU-T G.993.5-friendly ITU-T G.993.2 operation in the downstream direction" (see Annex X) and the bit "ITU-T G.993.5" are both set to ZERO in the VTU-O MS message.</p>
Pilot sequence length multiple of 4 in full ITU-T G.993.5-friendly ITU-T G.993.2 operation	<p>This bit shall be set to ONE if and only if set to ONE in both the last previous CL message and the last previous CLR message. If set to ONE, this bit indicates that "pilot sequence length multiple of 4" is enabled. If set to ZERO, this bit indicates only pilot sequence lengths that are a power of 2 are enabled.</p> <p>If the "Full ITU-T G.993.5-friendly ITU-T G.993.2 operation" bit is set to ZERO in the VTU-O MS message, then this bit shall be ignored by the VTU-R.</p>

Table Y.2 – VTU-O MS message NPar(2) bit definitions

ITU-T G.994.1 NPar(2) bit	Definition of NPar(2) bit
Upstream FDPS in full ITU-T G.993.5-friendly ITU-T G.993.2 operation	<p>Set to ONE if and only if both the last previous CLR and the last previous CL messages have set this bit to ONE.</p> <p>If set to ONE, both the VTU-O and VTU-R shall operate as defined in this annex and support upstream FDPS.</p> <p>If the "Full ITU-T G.993.5-friendly ITU-T G.993.2 operation" bit is set to ZERO in the VTU-O MS message, then this bit shall be ignored by the VTU-R.</p>

Y.1.1.2 Handshake – VTU-R

Y.1.1.2.1 CLR messages (supplements clause 12.3.2.2.1 of ITU-T G.993.2)

Table 12-13 shall be extended with Table Y.3 as follows:

Table Y.3 – VTU-R CLR message NPar(2) bit definitions

ITU-T G.994.1 NPar(2) bit	Definition of NPar(2) bit
Full ITU-T G.993.5-friendly ITU-T G.993.2 operation	<p>If set to ONE, indicates that the VTU-R supports full compliance with this annex (ITU-T G.993.5-friendly ITU-T G.993.2 operation).</p> <p>If set to ONE, the ITU-T G.993.5 SPar(2) bit shall be set to ZERO (see Note).</p>
Pilot sequence length multiple of 4 in full ITU-T G.993.5-friendly ITU-T G.993.2 operation	<p>If set to ONE, this bit indicates the VTU-R supports pilot sequence lengths that are a multiple of 4. If set to ZERO, this bit indicates the VTU-R only supports pilot sequence lengths that are a power of 2.</p> <p>If set to ONE, the "Full ITU-T G.993.5-friendly ITU-T G.993.2 operation" bit shall also be set to ONE.</p>
Upstream FDPS in full ITU-T G.993.5-friendly ITU-T G.993.2 operation	<p>If set to ONE, indicates that the VTU-R supports upstream FDPS as defined in ITU-T G.993.5 when in full ITU-T G.993.5-friendly ITU-T G.993.2 operation.</p> <p>If set to ONE, the "Full ITU-T G.993.5-friendly ITU-T G.993.2 operation" bit shall also be set to ONE.</p>
NOTE – A VTU-R that has ITU-T G.993.5 capability enabled sets this NPar(2) bit to 0.	

Y.1.1.2.2 MS messages (supplements clause 12.3.2.2.2 of ITU-T G.993.2)

Table 12-16 shall be extended with Table Y.4 as follows:

Table Y.4 – VTU-R MS message NPar(2) bit definitions

ITU-T G.994.1 NPar(2) bit	Definition of NPar(2) bit
Full ITU-T G.993.5-friendly ITU-T G.993.2 operation	<p>Set to ONE if and only if both the last previous CLR and the last previous CL messages have set this bit to ONE.</p> <p>If set to ONE, both the VTU-O and VTU-R shall operate as defined in this annex.</p> <p>NOTE – If set to ONE, the bit "ITU-T G.993.5-friendly ITU-T G.993.2 operation in the downstream direction" (see Annex X) and the bit "ITU-T G.993.5" are both set to ZERO in the VTU-R MS message.</p>

Table Y.4 – VTU-R MS message NPar(2) bit definitions

ITU-T G.994.1 NPar(2) bit	Definition of NPar(2) bit
Pilot sequence length multiple of 4 in full ITU-TG.993.5-friendly ITU-T G.993.2 operation	This bit shall be set to ONE if and only if set to ONE in both the last previous CL message and the last previous CLR message. If set to ONE, this bit indicates that "pilot sequence length multiple of 4" is enabled. If set to ZERO, this bit indicates only pilot sequence lengths that are a power of 2 are enabled. If the "Full ITU-T G.993.5-friendly ITU-T G.993.2 operation" bit is set to ZERO in the VTU-R MS message, then this bit shall be ignored by the VTU-O.
Upstream FDPS in full ITU-T G.993.5-friendly ITU-T G.993.2 operation	Set to ONE if and only if both the last previous CLR and the last previous CL messages have set this bit to ONE. If set to ONE, both the VTU-O and VTU-R shall operate as defined in this annex and support upstream FDPS. If the "Full ITU-T G.993.5-friendly ITU-T G.993.2 operation" bit is set to ZERO in the VTU-R MS message, then this bit shall be ignored by the VTU-O.

Y.2 R-MSG1 (supplements clause 10.3.2.2 of [ITU-T G.993.5])

Field #2, "Maximum number of FEXT estimation symbols per super-frame", defines the maximum number (K_{max}) of symbols in the super-frame for which the VTU-R supports error sample reporting. The field shall be formatted as an unsigned integer with value $K_{max} = 0$.

Field #3, "Support of optional backchannel control parameters", indicate the optional values of control parameters supported by the VTU-R. The field shall be formatted as an unsigned integer with value 00_{16} .

Y.3 O-TA_UPDATE (supplements clause 10.4.2.1 of [ITU-T G.993.5])

Field #2, "Error report control parameters", defines the control parameters for each of the vectored bands indicated in O-SIGNATURE. The VTU-R shall ignore the error report control parameters.

Field #3, "SOC Repetition Factor", defines the SOC repetition factor, $1/R$, as set by the VCE. The field shall be represented as an unsigned integer with value $1/R = 10$.

Field #4, "FEXT estimation symbols per super-frame", defines the number of symbols (K) in the super-frame for which a clipped error sample shall be reported. The field shall be formatted as an unsigned integer with value $K = 0$.

Y.4 R-P-VECTOR 2 (replaces clause 10.4.4.5 of [ITU-T G.993.5])

At sync symbol positions, the R-P-VECTOR 2 signal shall contain sync symbols, modulated as defined for the R-P-VECTOR 1 signal. At other symbol positions, the symbols shall be modulated as for the R-P-TRAINING 2 signal, with the extended SOC channel being established.

Transmission of R-P-VECTOR 2 enables the VCE to estimate upstream FEXT channels from the vectored lines into the initializing line, and update the estimates of the upstream FEXT from the initializing lines into the vectored lines.

During the sync symbols, the SOC is in the inactive state. During the other symbols, the SOC is in the active state, and the VTU-R shall transmit the R-IDLE message.

The duration of R-P-VECTOR 2 signal is controlled by the VTU-O. Within 64 symbols after the last symbol of the O-P-SYNCHRO V4 signal, the VTU-R shall end the transmission of the R-P-VECTOR 2 signal.

The R-P-VECTOR 2 signal shall be followed by the R-P-SYNCHRO V2 signal.

NOTE – The R-P-VECTOR 2 signal is identical to the ITU-T G.993.5 R-P-VECTOR 2 signal without extended SOC and with the VTU-R transmitting R-IDLE messages instead of R-ERROR-FEEDBACK messages.

Y.5 O-PMS (supplements clause 10.5.2.1 of [ITU-T G.993.5])

Field #2, "Showtime backchannel encapsulation", defines whether the Showtime backchannel is encapsulated into eoc messages or into Layer 2 Ethernet packets. The VTU-R shall ignore this field.

Field #3, "Layer 2 VCE MAC Address", defines the VCE MAC Address to be used by the NT as MAC destination address in case Layer 2 Ethernet encapsulation is used. The VTU-R shall ignore this field.

Field #4, "Layer 2 Line_ID", defines the Line_ID to be used by the NT in case Layer 2 Ethernet encapsulation is used. The VTU-R shall ignore this field.

Y.6 eoc messages for backchannel configuration (replaces clause 8.1 of [ITU-T G.993.5])

During Showtime, the VTU-O shall not send a backchannel configuration eoc command.

NOTE – At the start of Showtime, the backchannel is inactive. In absence of activation by the VTU-O through a backchannel configuration eoc command, the backchannel remains inactive throughout Showtime.

Y.7 Loop diagnostic mode procedures (replaces clause 12.4)

The loop diagnostic mode procedure is identical to the ITU-T G.993.5 loop diagnostic mode procedure.

Appendix I

Example values of DPBO parameters to protect ADSL2plus for clause C.3

(This appendix does not form an integral part of this Recommendation.)

This appendix defines example values of DPBO parameters defined in clause 7.3.1.2.13 of [ITU-T G.997.1].

These example values are for reducing crosstalk to ADSL2plus.

The set of breakpoints defining PSDMASKds(t_i , PSD_i) should be monotonic in frequency, i.e., $t_i \leq t_{i+1}$ for $0 < i \leq 32$, except when the DPBOLFO function is used. An interruption in the monotonic frequency progression indicates that DPBOLFO is requested and that the breakpoints following the interruption are for the DPBOLFO.

NOTE – PSDMASKds in this appendix is the ITU-T G.997.1 parameter that is referred to as MIBMASKds in this Recommendation.

I.1 Example PSD parameters

In this clause, PSD parameters to define PEPSD(f), PSDMASKds(f) and DPBOMPSD(f) are described. In Table I.1, DPBOEPSD, DPBOPSDMASKds(f), DPBOLFO and DPBOMUS are defined.

Table I.1 – PSD parameters of DPBO

	<i>DPBOEPSD</i> (dBm/Hz)	<i>DPBOPSDMASKds</i> (dBm/Hz)	<i>DPBOLFO</i> (dBm/Hz)	<i>DPBOMUS</i> (dBm/Hz)
VDSL2 in the building	Limit PSD mask = Table C.5	Limit PSD mask = Table C.9	-100	-100
VDSL2 from the cabinet	Limit PSD mask = Table C.5	Limit PSD mask = Table C.5 or Table C.6		

I.2 Example Cable parameters

In this clause, cable parameters to define PEPSD(f) are exemplified. PEPSD(f) is defined as the following equation:

$$PEPSD(f) = DPBOEPSD(f) - \left(DPBOESCMA + DPBOESCMB \cdot \sqrt{f} + DPBOESCMC \cdot f \right) DPBOESEL$$

In Table I.2, DPBOESCMA, DPBOESCMB and DPBOESCMC are defined.

Table I.2 – E-side cable model

	DPBOESCMA (No-dimension)	DPBOESCMB (1/√MHz)	DPBOESCMC (1/MHz)
VDSL2 in the building	$-10 \text{Log} \left(\frac{DPBOESEL + DPBORSEL}{DPBORSEL} \right)$	1	0
VDSL2 from the cabinet			

$DPBOESEL = length(m) \times 1(\sqrt{MHz}) \times 0.0259(dB/[m\sqrt{MHz}])$; with *length* (m) equal to the distance in metres between CO and Cabinet (for Japanese cable).

$DPBORSEL = length (m) \times 1(\sqrt{MHz}) \times 0.0259 (dB / [m\sqrt{MHz}])$; with *length* (m) equal to the distance in metres between Cabinet and VTU-R (for Japanese cable).

I.3 Example frequency parameters

In this clause, frequency parameters to define a frequency range where DPBO is in action are described. In Table I.3, DPBOFMIN is from which DPBO starts and DPBOFMAX is at which DPBO ends.

Table I.3 – Frequency range of DPBO

	<i>DPBOFMIN</i> (kHz)	<i>DPBOFMAX</i> (kHz)
VDSL2 in the building	138	2 208
VDSL2 from the cabinet		

Appendix II

Impact of loop and VTU impedance mismatch on the Hlog accuracy

(This appendix does not form an integral part of this Recommendation.)

This appendix provides a discussion regarding the effects on measured accuracy of $Hlog(f)$ when there is a mismatch between a nominal loop termination impedance of $100\ \Omega$ and the actual termination impedance (Z_{VTU}) provided by the VTU. This appendix is meant to provide additional technical details regarding the accuracy requirements for the $Hlog(k \times G \times \Delta f)$ test parameter.

Figure II.1 shows the reference diagram for computing reference received PSD with a spectrum or network analyzer.

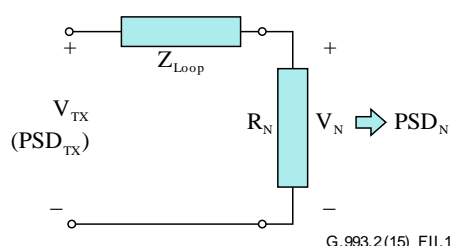

Figure II.1 – Measurement of received PSD by network or spectrum analyzer

Z_{loop} is the impedance of the loop as seen by the network analyzer looking into the test loop. This loop impedance is dependent on the loop topology and may vary with frequency.

R_N is the input impedance of the network analyzer and we assume $R_N = 100\ \Omega$. This value is independent of frequency.

The power spectral density of the received signal as seen by the network analyzer may be represented as:

$$PSD_N = \frac{|V_{Tx}|^2}{\Delta f} \cdot \frac{R_N}{|Z_{loop} + R_N|^2} \quad (\text{II.1})$$

with Δf representing the subcarrier spacing of 4.3125 kHz.

Figure II.2 shows the reference diagram for computing the PSD received by the VTU.

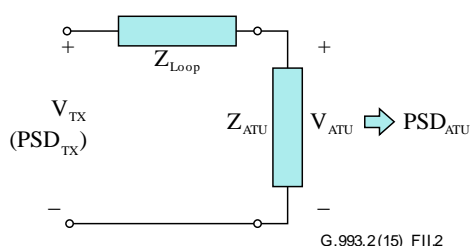

Figure II.2 – Measurement of PSD received by VTU

Z_{loop} is the same loop impedance as for the reference case above in Figure II.1; this is the impedance of the line seen by the VTU looking into the loop.

Z_{VTU} is the input impedance of the VTU as seen by the test loop.

The power spectral density of the received signal as seen by the VTU may be represented as:

$$PSD_{ATU} = \frac{|V_{Tx}|^2}{\Delta f} \cdot \frac{|Z_{ATU}|}{|Z_{loop} + Z_{ATU}|^2} \quad (II.2)$$

with Δf representing the subcarrier spacing of 4.3125 kHz.

The difference between equations (II.1) and (II.2) is the error in the receive PSD. Assuming that the transmit PSDs are identical for each case, this difference would represent the error in the $H\log(k \times G \times \Delta f)$ measurement. Hence, the $H\log(k \times G \times \Delta f)$ error in dB may be represented as follows:

$$Error_{dB} = 10 \cdot \log\left(\frac{PSD_N}{PSD_{ATU}}\right) = 10 \cdot \log\left(\frac{(R_N)}{|Z_{ATU}|} \cdot \frac{|Z_{ATU} + Z_{loop}|^2}{|R_N + Z_{loop}|^2}\right) \quad (II.3)$$

The above error expression in dB per equation (II.3) also represents the (contribution of Z_{loop} and Z_{VTU} variation to the) $H\log(k \times G \times \Delta f)$ accuracy in dB.

Figure II.3 shows a plot of the $H\log(f)$ error in dB vs. the VTU input impedance, for different loop impedances that vary from 10 Ω to 200 Ω .

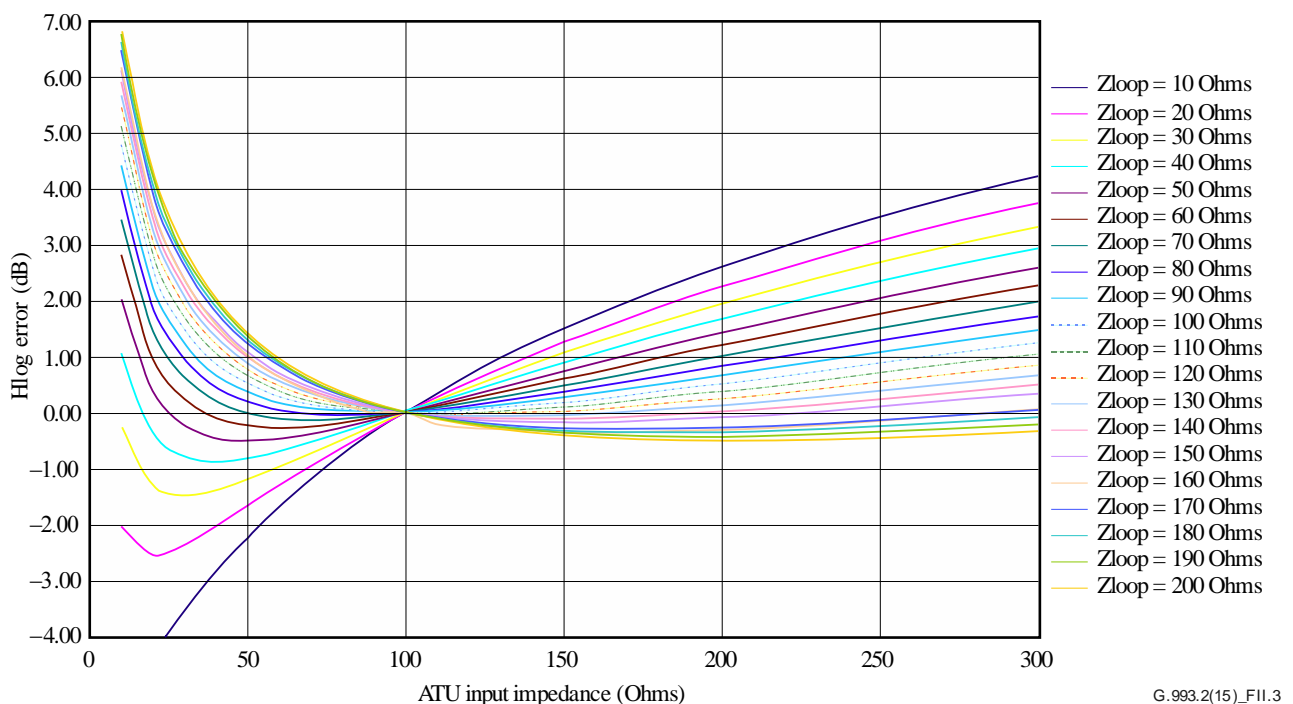

Figure II.3 – Hlog(f) error in dB as a function of loop and VTU impedance variations

Regarding the variation of $H\log(f)$ error with input impedances, the following can be observed:

- This Recommendation does not define any input impedance requirements for VTUs. Similarly, this Recommendation does not define any requirements on return loss. Therefore, VTU implementers are free to design for any input impedance to optimize VTU performance.
- Although it can be observed that the transmit PSD is reported relative to 100 Ω , the loop impedance will generally be different from 100 Ω and the resulting transmit PSD will vary accordingly.

- The VTU input impedance varies among those from different manufacturers.
- The VTU input impedance varies with frequency, which is dependent on implementation.
- If the VTU input impedance is equal to the reference impedance of the network analyzer, i.e., $Z_{VTU} = R_N$, and everything else is perfect, then the error is zero.
- The curves in Figure II.3 do not include any tolerance for components inside the VTU. This tolerance is implementation dependent.

The actual input impedance of a VTU is complex. The impedance values shown in Figure II.3 are the equivalent real Ohmic values.

Bibliography

- [b-ATIS-0600023] ATIS-0600023 (2008) – *Guidance for the Use of Upstream Power Back Off Parameters for Recommendation ITU-T G.993.2 Annex A.*

SERIES OF ITU-T RECOMMENDATIONS

Series A	Organization of the work of ITU-T
Series D	General tariff principles
Series E	Overall network operation, telephone service, service operation and human factors
Series F	Non-telephone telecommunication services
Series G	Transmission systems and media, digital systems and networks
Series H	Audiovisual and multimedia systems
Series I	Integrated services digital network
Series J	Cable networks and transmission of television, sound programme and other multimedia signals
Series K	Protection against interference
Series L	Environment and ICTs, climate change, e-waste, energy efficiency; construction, installation and protection of cables and other elements of outside plant
Series M	Telecommunication management, including TMN and network maintenance
Series N	Maintenance: international sound programme and television transmission circuits
Series O	Specifications of measuring equipment
Series P	Terminals and subjective and objective assessment methods
Series Q	Switching and signalling
Series R	Telegraph transmission
Series S	Telegraph services terminal equipment
Series T	Terminals for telematic services
Series U	Telegraph switching
Series V	Data communication over the telephone network
Series X	Data networks, open system communications and security
Series Y	Global information infrastructure, Internet protocol aspects, next-generation networks, Internet of Things and smart cities
Series Z	Languages and general software aspects for telecommunication systems