

International Telecommunication Union

ITU-T

TELECOMMUNICATION
STANDARDIZATION SECTOR
OF ITU

G.9960

Amendment 2
(04/2016)

SERIES G: TRANSMISSION SYSTEMS AND MEDIA,
DIGITAL SYSTEMS AND NETWORKS

Access networks – In premises networks

Unified high-speed wire-line based home
networking transceivers – System architecture and
physical layer specification

Amendment 2

Recommendation ITU-T G.9960 (2015) – Amendment 2

ITU-T



ITU-T G-SERIES RECOMMENDATIONS

TRANSMISSION SYSTEMS AND MEDIA, DIGITAL SYSTEMS AND NETWORKS

INTERNATIONAL TELEPHONE CONNECTIONS AND CIRCUITS	G.100–G.199
GENERAL CHARACTERISTICS COMMON TO ALL ANALOGUE CARRIER-TRANSMISSION SYSTEMS	G.200–G.299
INDIVIDUAL CHARACTERISTICS OF INTERNATIONAL CARRIER TELEPHONE SYSTEMS ON METALLIC LINES	G.300–G.399
GENERAL CHARACTERISTICS OF INTERNATIONAL CARRIER TELEPHONE SYSTEMS ON RADIO-RELAY OR SATELLITE LINKS AND INTERCONNECTION WITH METALLIC LINES	G.400–G.449
COORDINATION OF RADIOTELEPHONY AND LINE TELEPHONY	G.450–G.499
TRANSMISSION MEDIA AND OPTICAL SYSTEMS CHARACTERISTICS	G.600–G.699
DIGITAL TERMINAL EQUIPMENTS	G.700–G.799
DIGITAL NETWORKS	G.800–G.899
DIGITAL SECTIONS AND DIGITAL LINE SYSTEM	G.900–G.999
MULTIMEDIA QUALITY OF SERVICE AND PERFORMANCE – GENERIC AND USER-RELATED ASPECTS	G.1000–G.1999
TRANSMISSION MEDIA CHARACTERISTICS	G.6000–G.6999
DATA OVER TRANSPORT – GENERIC ASPECTS	G.7000–G.7999
PACKET OVER TRANSPORT ASPECTS	G.8000–G.8999
ACCESS NETWORKS	G.9000–G.9999
Metallic access networks	G.9700–G.9799
Optical line systems for local and access networks	G.9800–G.9899
In premises networks	G.9900–G.9999

For further details, please refer to the list of ITU-T Recommendations.

Recommendation ITU-T G.9960

Unified high-speed wire-line based home networking transceivers - System architecture and physical layer specification

Amendment 2

Summary

Recommendation ITU-T G.9960 belongs to the family of ITU-T G.996x Recommendations. Recommendation ITU-T G.9960 specifies the system architecture and physical (PHY) layer for wireline-based home networking transceivers which are capable of operating over premises' wiring, including inside telephone wiring, coaxial cable, and power-line wiring. It complements the data link layer (DLL) specification in Recommendation ITU-T G.9961, and the power spectral density (PSD) specification in Recommendation ITU-T G.9964.

Corrigendum 1 (2015) fixes a couple of minor errors.

Amendment 1 (2015) adds the new profile for 200 MHz baseband coax, and added support for a mechanism for piggybacked delayed acknowledgement.

Corrigendum 2 (2016) clarifies the PSD related fields.

This Amendment 2 adds a 200 MHz bandplan for telephone line baseband, specification of longitudinal conversion loss and increased granularity of the PSD fields.

History

Edition	Recommendation	Approval	Study Group	Unique ID*
1.0	ITU-T G.9960	2009-10-09	15	11.1002/1000/9679
2.0	ITU-T G.9960	2010-06-11	15	11.1002/1000/10704
3.0	ITU-T G.9960	2011-12-16	15	11.1002/1000/11403
3.1	ITU-T G.9960 (2011) Amd.1	2014-01-13	15	11.1002/1000/12087
4.0	ITU-T G.9960	2015-07-03	15	11.1002/1000/12400
4.1	ITU-T G.9960 (2015) Cor. 1	2015-11-22	15	11.1002/1000/12538
4.2	ITU-T G.9960 (2015) Amd. 1	2015-11-22	15	11.1002/1000/12537
4.3	ITU-T G.9960 (2015) Cor. 2	2016-04-13	15	11.1002/1000/12824
4.4	ITU-T G.9960 (2015) Amd. 2	2016-04-13	15	11.1002/1000/12818

* To access the Recommendation, type the URL <http://handle.itu.int/> in the address field of your web browser, followed by the Recommendation's unique ID. For example, <http://handle.itu.int/11.1002/1000/11830-en>.

FOREWORD

The International Telecommunication Union (ITU) is the United Nations specialized agency in the field of telecommunications, information and communication technologies (ICTs). The ITU Telecommunication Standardization Sector (ITU-T) is a permanent organ of ITU. ITU-T is responsible for studying technical, operating and tariff questions and issuing Recommendations on them with a view to standardizing telecommunications on a worldwide basis.

The World Telecommunication Standardization Assembly (WTSA), which meets every four years, establishes the topics for study by the ITU-T study groups which, in turn, produce Recommendations on these topics.

The approval of ITU-T Recommendations is covered by the procedure laid down in WTSA Resolution 1.

In some areas of information technology which fall within ITU-T's purview, the necessary standards are prepared on a collaborative basis with ISO and IEC.

NOTE

In this Recommendation, the expression "Administration" is used for conciseness to indicate both a telecommunication administration and a recognized operating agency.

Compliance with this Recommendation is voluntary. However, the Recommendation may contain certain mandatory provisions (to ensure, e.g., interoperability or applicability) and compliance with the Recommendation is achieved when all of these mandatory provisions are met. The words "shall" or some other obligatory language such as "must" and the negative equivalents are used to express requirements. The use of such words does not suggest that compliance with the Recommendation is required of any party.

INTELLECTUAL PROPERTY RIGHTS

ITU draws attention to the possibility that the practice or implementation of this Recommendation may involve the use of a claimed Intellectual Property Right. ITU takes no position concerning the evidence, validity or applicability of claimed Intellectual Property Rights, whether asserted by ITU members or others outside of the Recommendation development process.

As of the date of approval of this Recommendation, ITU had received notice of intellectual property, protected by patents, which may be required to implement this Recommendation. However, implementers are cautioned that this may not represent the latest information and are therefore strongly urged to consult the TSB patent database at <http://www.itu.int/ITU-T/ipr/>.

© ITU 2016

All rights reserved. No part of this publication may be reproduced, by any means whatsoever, without the prior written permission of ITU.

Table of Contents

	Page
1 Scope.....	1
2 References.....	1
3 Definitions	2
4 Abbreviations and acronyms	6
5 Home network architecture and reference models	9
5.1 Home network architecture and topology	9
5.2 Reference models	21
5.3 Management-plane reference model	25
6 Profiles.....	26
6.1 Low-complexity profile (LCP).....	26
6.2 Standard profile	26
7 Physical layer specification	27
7.1 Medium independent specification.....	27
7.2 Medium dependent specification.....	105
Annex A – Regional requirements for North America.....	113
Annex B	114
Annex C – Regional requirements for Japan	115
C.1 Scope	115
C.2 Medium dependent specification.....	115
Annex D	119
Annex E	120
Annex F – Usage of ITU-T G.9960 for optical transmission	121
F.1 Scope	121
F.2 Media dependent specification	121
Annex G – Test vectors.....	123
G.1 PFH test vectors.....	123
G.2 Scrambler test vectors.....	123
G.3 FEC encoder test vectors	124
G.4 Constellation encoder test vectors	124
G.5 Constellation scrambler test vectors	125
G.6 Preamble generation test vectors	126
Appendix I – Examples of home network topologies.....	128
Appendix II – Spectral usage	132
II.1 Scope	132
II.2 Spectral usage in Japan.....	132
Appendix III – Priority mapping.....	135

	Page
Appendix IV – Smart grid applications based on ITU-T G.9960	136
IV.1 Introduction	136
IV.2 SGH devices	136
IV.3 Architecture	136
IV.4 Interconnection with narrowband networking technologies	138
IV.5 Authorized admission and authentication	139
Appendix V – Electric vehicle applications based on ITU-T G.9960	141
V.1 Introduction	141
V.2 EVSE and EV devices	141
V.3 Overall network architecture	144
V.4 Authorization of an EV	145
V.5 Charging an EV without an EVSE	145
Appendix VI – Support of AMI applications in ITU-T G.9960	146
VI.1 Introduction	146
VI.2 AMI topology	146
VI.3 ITU-T G.9960 AMI architecture	147
VI.4 ITU-T G.9960 AMI mesh network	149
VI.5 Security concerns and AMI networks	149
VI.6 ITU-T G.9960 AMI coexistence with ITU-T G.9960 in-home systems	153
VI.7 ITU-T G.9960 AMI networks interaction with other systems in the local loop	153
VI.8 ITU-T G.9960 and the smart grid	153
Bibliography	154

Recommendation ITU-T G.9960

Unified high-speed wire-line based home networking transceivers - System architecture and physical layer specification

Amendment 2

Editorial note: This is a complete-text publication. Modifications introduced by this amendment are shown in revision marks relative to Recommendation ITU-T G.9960 (2015) plus its Corrigendum 1 (2015), Amendment 1 (2015) and Corrigendum 2 (2016).

1 Scope

This Recommendation specifies the system architecture and functionality for all components of the physical (PHY) layer of home network transceivers designed for the transmission of data over premises' wiring, including inside telephone wiring, coaxial cable, power-line wiring, plastic optical fibres, and any combinations of these.

Specifically, this Recommendation defines:

- the home network architecture and reference models
- the physical layer specification (PCS, PMA and PMD).

These transceivers are intended to be compatible with other devices sharing in-premises wiring.

Additionally, this Recommendation provides for spectrum notching for compatibility with amateur radio services.

2 References

The following ITU-T Recommendations and other references contain provisions which, through reference in this text, constitute provisions of this Recommendation. At the time of publication, the editions indicated were valid. All Recommendations and other references are subject to revision; users of this Recommendation are therefore encouraged to investigate the possibility of applying the most recent edition of the Recommendations and other references listed below. A list of the currently valid ITU-T Recommendations is regularly published. The reference to a document within this Recommendation does not give it, as a stand-alone document, the status of a Recommendation.

- [[ITU-T G.117](#)] [Recommendation ITU-T G.117 \(1996\), *Transmission aspects of unbalance about earth.*](#)
- [[ITU-T G.9961](#)] Recommendation ITU-T G.9961 (2015), *Unified high-speed wire-line based home networking transceivers – Data link layer specification.*
- [[ITU-T G.9964](#)] Recommendation ITU-T G.9964 (2011), *Unified high-speed wireline-based home networking transceivers – Power spectral density specification.*
- [[ITU-T O.9](#)] [Recommendation ITU-T O.9 \(1999\), *Measuring arrangements to assess the degree of unbalance about earth.*](#)
- [[ITU-T X.1035](#)] Recommendation ITU-T X.1035 (2007), *Password-authenticated key exchange (PAK) protocol.*
- [IEEE 802.1D] IEEE 802.1D-2004, *IEEE Standard for Local and metropolitan area networks: Media Access Control (MAC) Bridges.*
- [FIPS 197] FIPS PUB 197 (2001), *Advanced encryption standard (AES).*
- [NIST-SP800-38C] NIST-SP800-38C (2004), *Recommendation for Block Cipher Modes of Operation: the CCM Mode for Authentication and Confidentiality.*

3 Definitions

This Recommendation defines the following terms:

3.1 address association table (AAT): A table that associates the MAC addresses of the application entities with the DEVICE_ID of the nodes through which these application entities can be reached.

3.2 alien domain: Any group of non-ITU-T G.9960 nodes connected to the same medium or which operate in close proximity. The bridging function to an alien domain, as well as coordination with an alien domain to avoid mutual interference is beyond the scope of this Recommendation.

3.3 bandplan: A specific range of the frequency spectrum that is associated with a domain. Multiple bandplans may be used in the same domain provided that each bandplan used is a subset of the largest bandplan specified for the domain and a superset of the smallest bandplan specified for the domain. The bandplan is defined by a lower frequency and upper frequency except for RF, which is defined by a bandwidth and centre frequency.

3.4 baseband: A frequency band defined by an up-convert frequency $F_{UC} = 0$ and an up-shift frequency $F_{US} = F_{SC} \times N/2$ (see Table 7-67).

3.5 bridge to alien domain/network: An application device implementing an L2 or L3 bridging function to interconnect an ITU-T G.9960 domain to an alien domain (or alien network). Bridging to alien domains/networks is beyond the scope of this Recommendation.

3.6 broadcast: A type of communication where a node sends the same frame simultaneously to all other nodes in the home network or in the domain.

3.7 carrier sense (CRS): Generated by the receiver, CRS indicates that the medium is busy, i.e., a PHY frame, or sequence of PHY frames, or a special signal (e.g., INUSE, PR) is currently transmitted on the medium by another node. CRS may be either a physical carrier sense signal or a virtual carrier sense indicator.

- Physical carrier sense is generated by analysing physical signals present on the medium.
- Virtual carrier sense is generated based on the information on the PHY frame duration or PHY frame sequence duration derived from the frame header or communicated to a node by other means (e.g., in another frame).

3.8 channel: A transmission path between nodes. One channel is considered to be one transmission path. Logically, a channel is an instance of a communication medium used for the purpose of passing data between two or more nodes.

3.9 coding overhead: A part of the overhead used to carry the coding redundancy (such as redundancy bits of error correction coding or cyclic redundancy check (CRC)).

3.10 crosstalk: Disturbance (including frame collision) introduced by or due to operation of alien networks or other (independent) ITU-T G.9960 home networks.

3.11 data: Bits or bytes transported over the medium or via a reference point that individually convey information. Data includes both user (application) data and any other auxiliary information (overhead, including control, management, etc.). Data does not include bits or bytes that, by themselves, do not convey any information, such as the preamble.

3.12 data rate: The average number of bits communicated (transmitted) in a unit of time. The usual unit of time for data rate is 1 second.

3.13 DEVICE_ID: A unique identifier allocated to a node operating in the domain by the domain master during registration.

3.14 domain: A part of an ITU-T G.9960 home network comprising the domain master and all those nodes that are registered with the same domain master. In the context of this Recommendation, use of the term "domain" without a qualifier means "ITU-T G.9960 domain", and use of the term "alien domain" means "non-ITU-T G.9960 domain". Additional qualifiers (e.g., "power-line") may be added to either "domain" or "alien domain".

3.15 domain access point (DAP): The unique node in centralized mode (CM) that supports relay functionality through which all nodes communicate.

3.16 domain ID: A unique identifier of a domain.

3.17 domain master (DM): A node supporting the domain master functionality that manages (coordinates) all other nodes of the same domain (i.e., assigns bandwidth resources and manages priorities). Only one active domain master is allowed in a domain, and all nodes within a domain are managed (coordinated) by a single domain master. If a domain master fails, another node of the same domain, capable of operating as a domain master, should pick up the function of the domain master.

3.18 flow: A unidirectional stream of data between two nodes related to a specific application and/or characterized by a set of QoS requirements.

3.19 FLOW_ID: An identifier allocated to a flow for which parameterized QoS is used for traffic delivery. FLOW_IDs are assigned by and are unique to nodes that originate flows.

3.20 global master (GM): A function that provides coordination between different domains (such as communication resources, priority setting, policies of domain masters, and crosstalk mitigation). A global master may also convey management functions initiated by the remote management system (e.g., the Broadband Forum CPE WAN management protocol) to support broadband access. Detailed specification and use of this function is for further study.

3.21 guard interval: The time interval intended to mitigate corruption of data carried by the symbol due to inter-symbol interference (ISI) from the preceding symbols. In this Recommendation, the guard interval is implemented as a cyclic prefix.

3.22 hidden node: A node that cannot communicate directly with some other nodes within a domain.

NOTE – A hidden node may be able to communicate with another node or with a domain master using a relay node. A node that is hidden from a domain master uses a relay node as a proxy to communicate with the domain master.

3.23 home network: Two or more nodes that can communicate with each other either directly or through a relay node at the physical layer, or through an inter-domain bridge above the physical layer. A home network consists of one or more domains. In the context of this Recommendation, use of the term "home network" means "ITU-T G.9960 home network". Use of the term "alien home network" means "non-ITU-T G.9960 home network". Use of the term "network" without a qualifier means any combination of "ITU-T G.9960 home network", "non-ITU-T G.9960 home network" and "access network". Use of the term "alien network" means any combination of "non-ITU-T G.9960 home network" and "access network".

3.24 inter-domain bridge: A bridging function above the physical layer to interconnect nodes of two different domains.

3.25 jitter: A measure of the latency variation above and below the mean latency value. The maximum jitter is defined as the maximum latency variation above and below the mean latency value.

3.26 latency: A measure of the delay from the instant when the last bit of a frame has been transmitted through the assigned reference point of the transmitter protocol stack to the instant when a whole frame reaches the assigned reference point of the receiver protocol stack. Mean and maximum latency estimations are assumed to be calculated on the 99th percentile of all latency measurements.

If retransmission is set for a specific flow, retransmission time is a part of the latency for the protocol reference points above the MAC.

3.27 logical (functional) interface: An interface in which the semantic, syntactic, and symbolic attributes of information flows are defined. Logical interfaces do not define the physical properties of signals used to represent the information. It is defined by a set of primitives.

3.28 management overhead: A part of the overhead used for management purposes (such as home network discovery, channel estimation, acknowledgement, and establishing and terminating the flow).

3.29 medium: A wireline facility, of a single wire class, allowing physical connection between nodes. Nodes connected to the same medium may communicate on the physical layer, and may interfere with each other unless they use orthogonal signals (e.g., different frequency bands, different time periods).

3.30 multicast: A type of communication where a node sends the same frame simultaneously to one or more other nodes in the home network.

3.31 net data rate: The data rate available at the A-interface of the transceiver reference model.

3.32 node: Any network device that contains an ITU-T G.9960 transceiver. In the context of this Recommendation, use of the term "node" without a qualifier means "ITU-T G.9960 node", and use of the term "alien node" means "non-ITU-T G.9960 node". Additional qualifiers (e.g., "relay") may be added to either "node" or "alien node".

3.33 operational modes of a domain:

– **peer-to-peer mode (PM):** A mode of domain operation in which all nodes use only peer-to-peer (P2P) communication with other nodes (without relay nodes). In peer-to-peer mode, no relay nodes are allowed;

– **centralized mode (CM):** A mode of domain operation in which all nodes use relayed communication (REL) with a single relay node. In centralized mode, only one relay node is allowed and it is known as the domain access point (DAP).

NOTE – A DAP is likely to serve also as a domain master.

– **unified mode (UM):** A mode of domain operation in which all nodes within a domain communicate using P2P or REL, as necessary, while some of the relay nodes may have additional functionalities. Unified mode can be used to support hidden nodes. In unified mode, more than one relay node is allowed.

NOTE – In UM, there is no domain access point defined.

3.34 passband: A frequency band defined by an up-convert frequency $F_{UC} = 0$ and an up-shift frequency $F_{US} \gg F_{SC} \times N/2$ (see Table 7-67).

3.35 peer-to-peer communication: A type of communication within a domain in which direct signal traffic is established between nodes with no relay nodes.

3.36 physical interface: An interface defined in terms of physical properties of the signals used to represent the information transfer. A physical interface is defined by signal parameters such as power (power spectrum density), timing, and connector type.

3.37 primitives: Basic measures of quantities obtained locally or reported by other nodes of the domain. Performance primitives are basic measurements of performance-related quantities, categorized as events, anomalies and defects. Primitives may also be basic measures of other quantities (e.g., a.c. or battery power).

3.38 priority: A value assigned to the specific frame(s) that determines the relative importance of transmitting frame(s) during the upcoming opportunity to use the medium.

- 3.39 quality of service (QoS):** A set of quality requirements on the communications in the home network. Support of quality of service refers to mechanisms that can provide a different priority to different flows, or can guarantee a measurable level of performance for a flow based on a set of quality of service parameters.
- 3.40 radio frequency (RF):** A frequency band defined by an up-convert frequency $F_{UC} > 0$ and a centre frequency $F_C = F_{UC} + F_{US} \gg F_{SC} \times N/2$ (see Tables 7-67 and 7-68).
- 3.41 reference point:** A location in a signal flow, either logical or physical, that provides a common point for observation and/or measurement of the signal flow.
- 3.42 registration:** The process used by a node to join the domain.
- 3.43 relay node:** A node supporting relay functionality that acts as an intermediary node, through which other nodes of the same domain can pass their traffic (data, control, or management).
- 3.44 relayed communication (REL):** A type of communication within a domain in which a node can communicate with other nodes through a relay node. The relay node receives a signal from a node and forwards it to the addressee nodes.
- 3.45 residential gateway:** A device providing, among other functions, bridging between the access network and the home network. Residential gateways are beyond the scope of this Recommendation.
- 3.46 stopband:** The portion of the frequency spectrum that is not allowed for transmission.
- 3.47 subcarrier (OFDM subcarrier):** The centre frequency of each orthogonal frequency division multiplexing (OFDM) subchannel on to which bits may be modulated for transmission over the subchannel.
- 3.48 subcarrier spacing:** The difference between frequencies of any two adjacent orthogonal frequency division multiplexing (OFDM) subcarriers.
- 3.49 subchannel (OFDM subchannel):** A fundamental element of orthogonal frequency division multiplexing (OFDM) modulation technology. The OFDM modulator partitions the channel bandwidth into a set of parallel subchannels.
- 3.50 symbol (OFDM symbol):** A fixed time-unit of an orthogonal frequency division multiplexing (OFDM) signal carrying one or more bits of data. An OFDM symbol consists of multiple sine-wave signals or subcarriers, each modulated by a number of data bits and transmitted during a fixed time called the symbol period.
- 3.51 symbol frame:** A frame composed of bits of a single orthogonal frequency division multiplexing (OFDM) symbol period. Symbol frames are exchanged over the δ -reference point between the physical medium attachment (PMA) and physical medium dependent (PMD) sublayers of the PHY.
- 3.52 symbol rate:** The rate, in symbols per second, at which orthogonal frequency division multiplexing (OFDM) symbols are transmitted by a node on to a medium. Symbol rate is calculated only for time periods of continuous transmission.
- 3.53 throughput:** The amount of data transferred from the A-interface of a source node to the A-interface of a destination node over some time interval, expressed as the number of bits per second.
- 3.54 transmission overhead:** A part of the overhead used to support transmission over the line (e.g., samples of the cyclic prefix, inter-frame gaps, and silent periods).
- 3.55 unicast:** A type of communication where a node sends a frame to another single node.
- 3.56 wire class:** One of the classes of wire, which has the same general characteristics: coaxial cable, home electrical-power wire, telephone-line wire and Category 5 cable.

3.57 actual PSD (APSD): PSD injected by a node during a transmission. It is lower than or equal to the TxPSD, and PSD ceiling, if specified.

3.58 maximum actual PSD (APSD_MAX): Highest value of the actual PSD across the spectrum used for transmission. This value is always less than or equal to PSD ceiling.

3.59 PSD ceiling (PSDC): The PSD ceiling specifies the PSD level that is used to impose a limit (i.e., a ceiling function) on the transmit signal. The PSD ceiling is independent of frequency and indicated by a single value in dBm/Hz.

3.60 transmit PSD mask (TxPSD): Maximum PSD that a node is allowed to inject across the spectrum used for the transmission (see clause 7.1.5). This may be further limited by the PSD ceiling value.

3.61 transmitted power: Integral of the actual PSD over the spectrum used for transmission.

4 Abbreviations and acronyms

This Recommendation uses the following abbreviations and acronyms:

AAT	Address Association Table
ACE	Additional Channel Estimation
ACK	Acknowledgement
ADP	Application Data Primitives
AE	Application Entity
AMI	Advanced Meter Infrastructure
APC	Application Protocol Convergence
ASC	Active Subcarriers
BAT	Bit Allocation Table
CATV	Community Antenna Television
CB	Coax Baseband
CM	Centralized Mode
CRC	Cyclic Redundancy Check
CRF	Coax Radio Frequency
CRS	Carrier Sense
DAP	Domain Access Point
DID	Destination node Identifier
DLL	Data Link Layer
DM	Domain Master
DME	DLL Management Entity
DOD	Domain identifier
DRI	Duration Indication
DSL	Digital Subscriber Line
EHI	Extended Header Indication
EMS	Energy Management System

ESC	Energy Services Channel
ESI	Energy Services Interface
EVCf	Electric Vehicle Charging Facility
EVM	Error Vector Magnitude
EVSE	Electrical Vehicle Supply Equipment
FAck	Frame Acknowledgement
FEC	Forward Error Correction
FT	Frame Type
FTE	Frame Type Extension
FTSF	Frame-Type Specific Field
GM	Global Master
HAN	Home Area Network
HCS	Header Check Sequence
HE	Head End
HIS	Header Segmentation Indication
HRE	Header Repetition Encoder
HT	Home Terminal
IDB	Inter-Domain Bridge
IDFT	Inverse Discrete Fourier Transform
IDPS	Inter-Domain Presence Signal
IHD	In-Home Display
ISC	Inactive Subcarrier
ISI	Inter-Symbol Interference
LCP	Low-Complexity Profile
LDPC-BC	Low-Density Parity-Check Block-Code
LED	Light Emitting Diode
LFSR	Linear Feedback Shift Register
LLC	Logical Link Control
LSB	Least Significant Bit
LSSN	Lowest Segment Sequence Number
LV	Low Voltage
MAC	Medium Access Control
MAP	Medium Access Plan
MDI	Medium-Dependent Interface
MI	Multicast Indication
MIC	Message Integrity Check
MPDU	Media access control Protocol Data Unit

MSB	Most Significant Bit
MSC	Masked Subcarrier
NACK	Negative Acknowledgement
NME	Node Management Entity
NMK	Network Master Key
NMS	Network Management System
NN	Node-to-Node
NTR	Network Time Reference
OFDM	Orthogonal Frequency Division Multiplexing
P2P	Peer-To-Peer Communication
PB	Power-line Baseband
PBC	Public Broadcast Channel
PCS	Physical Coding Sublayer
PEV	Plug-in Electric Vehicle
PFH	PHY-Frame Header
PHEV	Plug-in Hybrid Electric Vehicle
PM	Peer-to-peer Mode
PMA	Physical Medium Attachment
PMD	Physical Medium Dependent
PME	PHY Management Entity
PMI	Physical Medium-independent Interface
PMSC	Permanently Masked Subcarrier
PON	Passive Optical Network
PP	Powerline Passband
PR	Priority Resolution
PRE	Payload Repetition Encoder
PSD	Power Spectral Density
PSDC	Power Spectral Density Ceiling
QC-LDPC-BC	Quasi-Cyclic Low-Density Parity-Check Block-Code
QoS	Quality of Service
RCM	Robust Communication Mode
REL	Relayed communication
RG	Residential Gateway
RMAP	Relayed Medium Access Plan
RMAP-A	Relayed Active Medium Access Plan
RMAP-D	Relayed Default Medium Access Plan
RMSC	Regionally Masked Subcarrier

SC	Security Controller
SGA	Smart Grid Access
SGH	Smart Grid HAN
SI	Scrambler Initialization
SID	Source node Identifier
SI-POF	Step-Index Polymer/Plastic Optical Fibres
SM	Subcarrier Mark
UAN	Utility Access Network
UM	Unified Mode

5 Home network architecture and reference models

5.1 Home network architecture and topology

An architectural model of the home network is presented in Figure 5-1. The model includes one or more domains, inter-domain bridges (IDB), and bridges to alien domains such as a WiFi or Ethernet home network, or a DSL or PON access network. The global master function coordinates resources such as bandwidth reservations, flow priorities, and operational characteristics between domains, and may convey the relevant functions initiated by a remote management system (e.g., as specified in [b-TR-069]) to support broadband access. Detailed specification and use of the global master function is for further study. The specification of bridges to alien domains and to the access network is beyond the scope of this Recommendation.

NOTE 1 – It is not necessary that all inter-domain bridges presented in Figure 5-1 be used. Depending on the application, domains could be daisy-chained, or star-connected, or could use another connection topology. Support of multi-route connections between domains is for further study.

NOTE 2 – It is possible to install multiple ITU-T G.9960 home networks (i.e., not connected by inter-domain bridges) per dwelling.

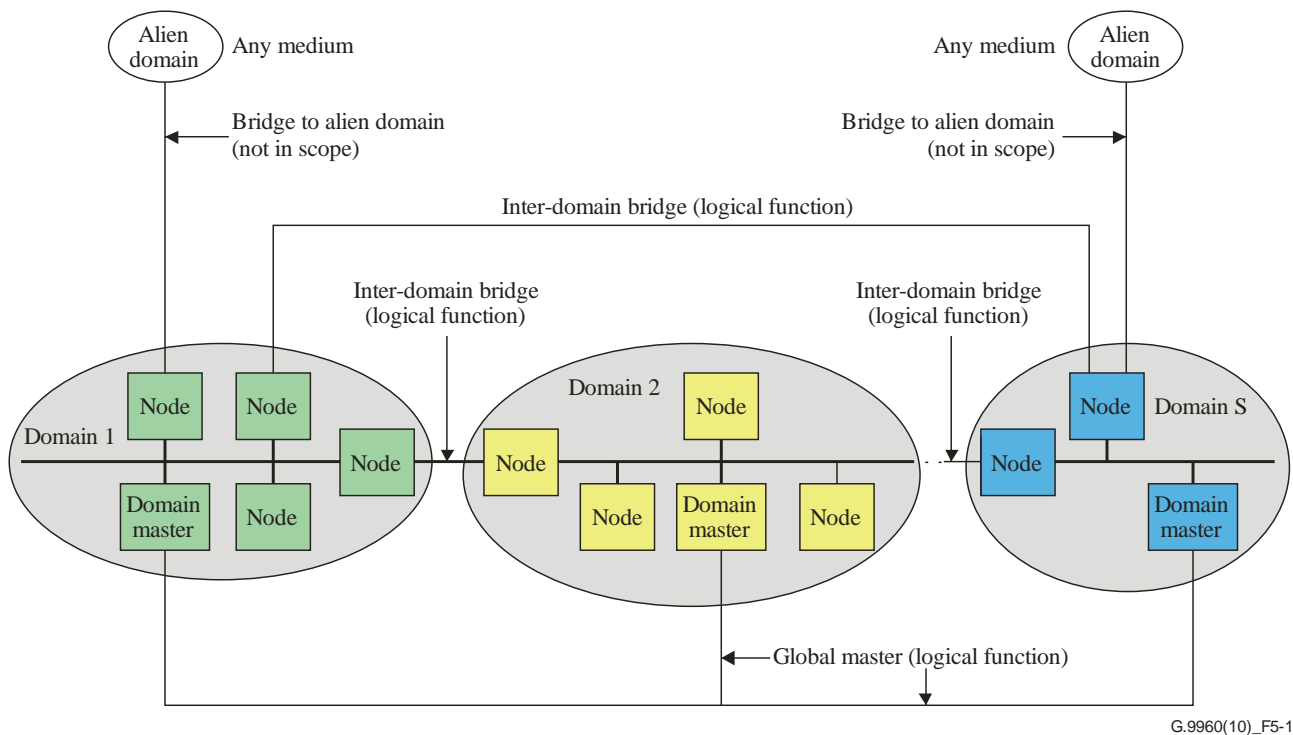

Figure 5-1 – Home network architecture reference model

A domain contains nodes connected to the same medium, where one node is acting as a domain master. Nodes of the same domain communicate via the medium over which the domain is established. Nodes connected to different domains communicate via inter-domain bridges (e.g., L2 or L3 bridging, see clause 5.1.6).

A domain shall be capable of supporting at least 32 registered nodes and may optionally support up to 250 registered nodes. Each node shall be capable of supporting simultaneous communication sessions with at least eight other nodes using dedicated sets of transmission parameters (e.g., runtime bit allocation tables (BATs)), different from the predefined BATs described in clause 7.1.4.2.2.1.

The scope of this Recommendation is limited to transceivers of all nodes capable of operating either with extended capabilities (e.g., domain master (DM), domain access point (DAP), relay node, or combinations thereof) or without extended capabilities in any domain. Other parts of this Recommendation, including inter-domain bridges, RGs (as a bridge to the access network), and bridges to alien domains, are beyond the scope of this Recommendation; however, this Recommendation defines all necessary means to support their functionality and the exchange of relevant information.

The domain master considers bridges to alien domains as application entities (AEs) of a node with certain requirements, while it considers inter-domain bridges as AEs of nodes whose interfaces (see clause 5.1.6) comply with this Recommendation.

5.1.1 Domains

5.1.1.1 General rules of operation

A domain as depicted in Figure 5-1 may include nodes with a range of capabilities including extended capabilities such as relay, domain master, and DAP functionality, as well as nodes with limited capabilities such as low-complexity profile (LCP) nodes.

The function of the domain master is to assign and coordinate resources (bandwidth and priorities) of all nodes in its domain. The following rules apply for any domain:

- 1) A home network may include one or more domains.
- 2) More than one domain may be established over the same medium, for example, by using orthogonal signals over different frequency bands.
- 3) The home network shall have a unique name. All domains of the same home network shall use this name.
- 4) The domain ID shall be used to identify a specific domain. Each domain in a home network shall have a unique domain ID.
- 5) All nodes within the same domain shall use the same domain ID.
- 6) Domains from independent home networks established over the same medium may interfere with each other (e.g., if they use the same frequency band). Coordination between domains of independent home networks sharing a common medium may be performed (see clause 8.14 in [\[ITU-T G.9961\]](#)).
- 7) All nodes in a domain shall be managed by a single domain master.
- 8) There shall be one and only one active domain master per domain. In case an active domain master is not assigned, fails, or is switched off, a domain master selection procedure is initiated to assign a new active domain master.
- 9) Nodes are not required to be domain master capable. That is, some nodes may not support the functionality necessary to become a domain master.
- 10) Nodes of the same home network that can communicate with each other directly at the physical layer (except crosstalk between closely routed wires) shall be assigned to the same domain.
- 11) The domain master shall assign a DEVICE_ID to a node during the node's registration process.
- 12) All nodes within a domain shall support P2P and REL (REL is considered as a subset of P2P, where the first destination address for the node is a relay node). For both P2P and REL, bandwidth resources and priorities of all nodes within the domain are managed by the domain master.
- 13) A node shall keep track of the domain where it associates and shall discard in the payload of MSG type PHY frames with DOD value different from 0 received from domains other than its own. These frames can be distinguished by examination of the DOD field in the PHY frame headers that are transmitted for these types of frames.
- 14) A node is required to report the existence of neighbouring domains to its domain master when it receives one or more PHY-frame headers containing a DOD value other than the one used in its domain or when it receives PHY-frame headers containing a DOD value of 0 (see clause 8.14 of [\[ITU-T G.9961\]](#)).

5.1.1.2 Modes of operation

A domain can operate in one of three modes: peer-to-peer mode (PM), centralized mode (CM), or unified mode (UM). Different domains within the home network can use different modes of operation, i.e., PM, CM, or UM. Examples of domains in different operational modes are presented in Appendix I.

Broadcast and multicast shall be supported in any domain, independent of their operational mode (PM, CM or UM).

In PM, only P2P shall be used in the domain. Thus, direct signal traffic is established between two communicating nodes. Figure 5-2 shows the use of P2P between nodes A and B. Frames addressed to nodes outside the domain are sent to the node associated with the inter-domain bridge (node C in Figure 5-2).

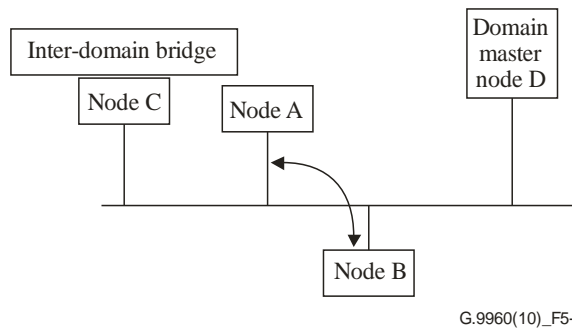

Figure 5-2 – Domain operating in peer-to-peer mode (PM)

In CM, only REL shall be used. Thus, any node of the domain can communicate with another node only through the DAP. The DAP receives signals from all nodes of the domain and further forwards them to the corresponding addressee nodes. Frames addressed to nodes outside the domain are forwarded by the DAP to the node associated with the inter-domain bridge (node C in Figure 5-3). Usually, but not necessarily, the DAP also serves as a domain master (Figure 5-3).

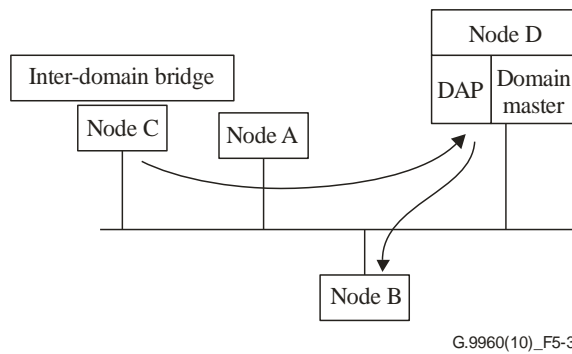
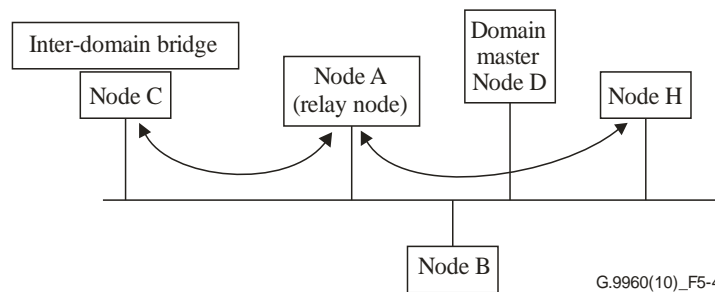

Figure 5-3 – Domain operating in centralized mode (CM)

In case of DAP failure, no communication between nodes in the domain is allowed.

In UM, a hidden node in a domain can communicate with another node through a relay node as shown in Figure 5-4. In the example, two nodes within the same domain (node C and node H) that are hidden from each other communicate with each other via the relay node (node A). Both nodes are managed by the domain master (node D) and can communicate directly with all other nodes. Frames addressed to nodes outside the domain are sent to the node associated with the inter-domain bridge (node C in Figure 5-4).



NOTE – Nodes C and H are hidden from each other.

Figure 5-4 – Domain operating in unified mode (UM) containing hidden nodes

5.1.1.3 Relationship between domain and medium

Figure 5-5 shows several examples of the relationships between domain, medium and wire class. Note that in Figure 5-5, each of the domains is shown to be associated with a single medium. This represents the focus of ITU-T G.9960; domains optimized to operate on a single wire class with multiple domains interconnected via inter-domain bridges. Figure 5-5 (A) shows an example segment of a home network comprising three different media: coax, telephone line and power line. A single domain exists on each medium and the domains are inter-connected by inter-domain bridges. Figure 5-5 (B) shows another example segment of a home network comprising telephone-line and power-line mediums. In this case, the telephone-line medium comprises two segments of telephone wire that are joined by splicing or at a connector. These two telephone-line segments are of a single wire class and therefore are a single medium. As shown in Figure 5-5 (A), there is a single domain on each medium and the domains are inter-connected by inter-domain bridges. Figure 5-5 (C) shows the example segment of a home network from Figure 5-5 (A), but also demonstrates the potential for having multiple domains on a medium. In Figure 5-5 (C), the telephone-line medium carries three domains and the power-line medium carries two domains. The multiple domains on each individual medium within a single network shall have orthogonal signalling to avoid interference. For example, on the power line, domain C5 must have signalling that is orthogonal to signalling on domain C6. These domains communicate via the same inter-domain bridges shown that connect the different media. These inter-domain bridges have multiple internal bridge ports to connect the domains operating on the same medium. Refer to Figure I.3 for an alternative representation of multiple domains on a single medium.

NOTE – It is possible to passively couple wire classes and operate them under a single domain. However, it is expected that such scenarios would occur very infrequently and such practices will be avoided if possible.

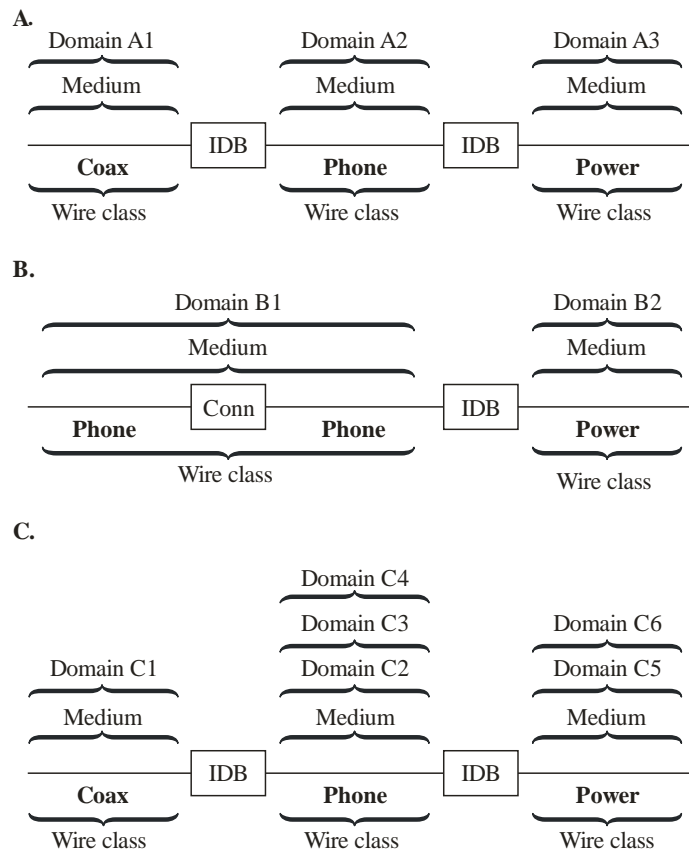

G9960(10)_F5-5

IDB Inter-domain bridge
 Conn Connector or splice connection

Figure 5-5 – Relationships between domain, medium and wire class

5.1.2 Node functionality

The main functions and capabilities of a node are summarized in Table 5-1.

Table 5-1 – Main functions and capabilities of a node

Function	Description and parameters
Medium access	Receives, interprets and acts upon the medium access plan (MAP)
Support of admission control protocol	Supports admission control protocol
Support of operational modes of the domain	Supports the operational mode (PM, CM, or UM) Complies with spectrum compatibility settings for the domain
Support of medium access rules	Accesses medium using medium access rules coordinated with the domain master
Support of security	Supports authentication and encryption key management procedures

Table 5-1 – Main functions and capabilities of a node

Function	Description and parameters
Collection and reporting of node information	Provides statistics: <ul style="list-style-type: none"> – List of visible nodes – List of addresses (AAT) – List of capabilities supported by the node – Performance statistics (data rate, error count, time stamps) – Statistics on detected neighbouring home networks
Request of bandwidth allocation	<ul style="list-style-type: none"> – Performs flow set up – Requests bandwidth allocations from the domain master in order to meet QoS requirements of flows
Support of retransmissions	Provides acknowledgment and retransmission of data units that were received with error
Support of extended capabilities	<ul style="list-style-type: none"> – Domain master – Domain access point (DAP) – Data relaying – MAP repeating – Domain master selection procedure – Security controller (SC)
Neighbouring domain interference mitigation	<p>Supports using near-orthogonal signals for generating and detecting the preamble, PR, INUSE and NACK signals for cases of low interference from neighbouring domains.</p> <p>Supports coordination between neighbouring domains in order to mitigate high interference (Note).</p>
Inter-domain communication	Acts as a proxy for the domain master for inter-domain communication such as MAC cycle alignment and coordination with neighbouring domains for interference mitigation (Note).
Support of management	Support node management
Support of power saving modes	Support of optional power saving modes: L1, L2, L3, L4
NOTE – These functionalities are specified in [ITU-T G.9961] .	

5.1.2.1 Domain master functionality

A domain master controls operation of the nodes in the domain. The main functions of a domain master are summarized in Table 5-2.

Table 5-2 – Domain master functionality

Function	Description
Indication of presence	Periodically communicates MAP to all nodes in the domain
Admission control	Admits new nodes to the domain Limits the number of nodes in a domain Facilitates departure of nodes from the domain
Determination of domain operation	Assigns mode of operation inside the domain (PM, CM, or UM) Supports hidden nodes by assigning MAP repeaters Supports synchronization of the MAC cycle to an external source (e.g., the a.c. line) Facilitates spectrum compatibility for the domain by assigning relevant limits on: <ul style="list-style-type: none"> – Frequency band – Maximum transmit power – PSD mask
Bandwidth allocation and QoS support	Assigns medium access rules to all nodes of the domain to facilitate support of QoS
Monitor status of the domain	Collects statistics of domain operation: <ul style="list-style-type: none"> – List of nodes in the domain – Topology – Performance statistics (data rate, error count) – Statistics on neighbouring domains
Communication with the global master (for further study)	Coordinates operation of the domain with other domains using the global master function
Backup master assignment	Assigning of a backup domain master to take over the domain master role
Neighbouring domain interference mitigation	Coordinates the usage of near-orthogonal signals for generating and detecting the preamble, PR, INUSE and NACK signals in the domain, in order to mitigate low interference from neighbouring domains. Supports coordination between domain masters of neighbouring domains in order to mitigate high interference (Note).
Inter-domain communication	Communicates with domain masters of neighbouring domains (using nodes as proxy if necessary). Inter-domain communication includes MAC cycle alignment and coordination with neighbouring domains for interference mitigation (Note).
Support of management	Support domain master management
Support of power saving modes	Support of optional power saving modes: L1, L2, L3, L4
NOTE – These functionalities are specified in [ITU-T G.9961] .	

At any given time, only one node is allowed to act as a domain master for a domain. All other nodes within the domain are managed (coordinated) by this domain master. If a domain master fails, another node of the same domain, capable of operating as a domain master, should pick up the function of the domain master.

5.1.3 Global master function

This clause provides an overview of the global master function. Detailed specification and use of this function are for further study.

The global master (GM) function interacts with domains and coordinates their operation by exchanging relevant information with domain masters via the logical M-interface as shown in Figure 5-6.

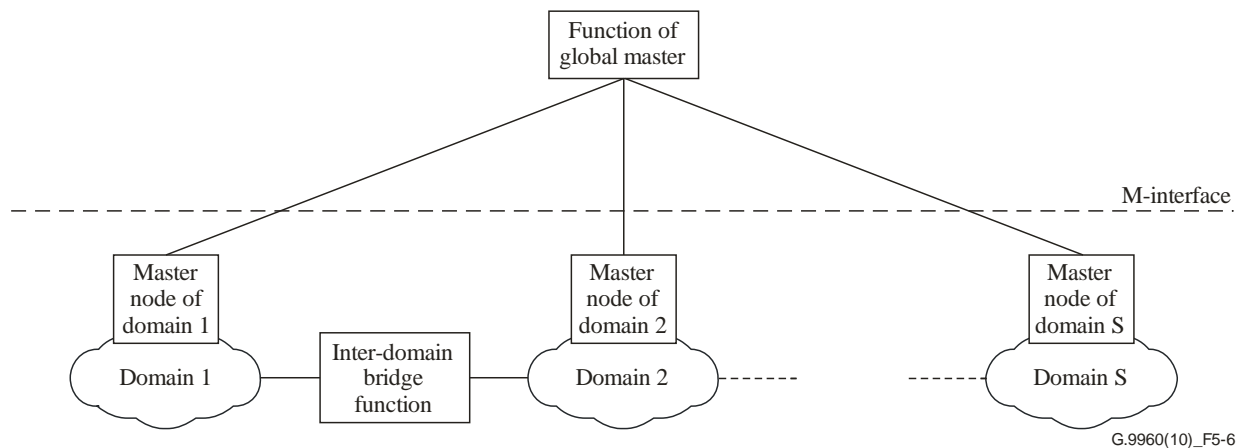

Figure 5-6 – Functional model of GM

The following rules apply to the GM:

- 1) In a multi-domain home network, the GM may coordinate some or all domains. For coordination, the GM exchanges information with domain masters of all coordinated domains via the M-interface. The GM may retrieve relevant domain-related data from domain masters and send control signals and data for coordination between domains to domain masters.
- 2) The M-interface is functional; its physical implementation is vendor discretionary. In case a domain master is replaced (e.g., as a result of a failure), the GM shall interface to the newly selected domain master.
- 3) The information exchange protocol between the GM and a domain master is unified for all domains.

NOTE – The GM does not limit the number of domains in the home network.

5.1.4 Quality of service (QoS)

Quality of service (QoS) is a measure of the quality of delivery of services in the home network, placing requirements on the transmission and queuing of traffic. This Recommendation supports two QoS methods: priority-based QoS and parameter-based QoS.

The QoS requirements are supported between nodes inside the same domain and between nodes connected to different domains if services communicated between nodes belong to different domains. In the latter case, inter-domain bridges are expected to not compromise the QoS requirements (such as latency). Inter-domain bridges are also expected to facilitate provisioning of QoS between nodes connected to different domains.

Parameter-based QoS mechanism operates per flow. Flows are set up, modified and terminated on a service basis. The characteristics of the service are used to select the QoS method used to deliver the traffic associated with the flow and to determine any relevant QoS parameters. Frames belonging to a specific flow are scheduled to be sent on to the medium in accordance with the defined QoS method. The ITU-T G.9960 QoS method handles both constant and variable data-rate traffic.

Priority-based QoS refers to a mechanism that provides different priorities for medium access based on the priority of the incoming traffic. All ITU-T G.9960 transceivers shall support priority-based QoS. The number of supported priority levels associated with the incoming application data primitives (ADPs) (at the A-interface) shall be eight (denoted from 0 to 7).

With priority-based QoS, the ITU-T G.9960 transceiver associates incoming frames with a certain priority queue, based on priority or other priority-related parameters associated with those frames. The ITU-T G.9960 priority-based QoS method defines the order in which frames from each queue will be sent to the medium and the order in which frames will be processed (and possibly dropped), based solely on the priority assigned to the queue. The number of supported priority queues may be less than eight. The mapping between the priority of the incoming frames and the associated priority queue shall be as recommended by [IEEE 802.1D] for user priority to traffic class mappings, as shown in Appendix III. Other methods of classification are for further study.

Parameter-based QoS refers to a mechanism that provides specific performance metrics (QoS parameters) for a given flow associated with the application (service), and resource allocation for medium access to meet these performance metrics. A set of these parameters may include, but is not limited to, data throughput, latency or jitter.

With parameter-based QoS, the ITU-T G.9960 transceiver associates each flow with a set of QoS parameters related to the particular service and with a certain queue. The ITU-T G.9960 parameter-based QoS method provides appropriate resources (e.g., bandwidth) necessary to communicate each flow through the medium so that QoS parameters associated with this flow are met. It also determines the order in which frames from each queue will be sent to the medium and the order in which frames will be processed (and possibly dropped) based on the knowledge of traffic parameters. The minimum number of supported flows (queues) depends on the profile.

5.1.5 Security function

The security function addresses secured operation over shared media. Besides admission procedures, which ensure that only permitted nodes can join a home network via one of its domains, this Recommendation defines point-to-point security, allowing authentication of each pair of nodes prior to communication and unique encryption keys for each pair of communicating nodes or per DLL multicast group.

NOTE – Point-to-point security generally improves security by building another layer of protection against an intruder that has broken through the admission control, and maintains full confidentiality for all communications within the home network. This makes ITU-T G.9960 suitable for installation in public places (hotels, small businesses, home offices) requiring at least the same grade of security and confidentiality as defined in the most recent specification for wireless LAN ([b-IEEE 802.11]).

The security function provides the following main features:

- encryption based on AES-128 [FIPS 197] and CCM mode [NIST-SP800-38C].
- advanced authentication and secure admission of nodes into a domain, based on [\[ITU-T X.1035\]](#);
- key management, including generation, secure communication, update, and termination of encryption keys;
- high confidentiality and integrity of all transactions, including point-to-point authentication and unique encryption keys;
- support of secure operation in the presence of relay nodes;

- allows simultaneous operation of distinct, separately secured domains on the same medium per the rules specified in clause 5.1.1.1;
- provides user-friendly procedures for setting up a secure network.

Security procedures that are user-friendly may require the user to set a password for each node prior to installation. The rest of the procedures necessary to establish and maintain security are facilitated automatically by the security controller (SC) function, without involvement of the user.

Nodes that do not include an appropriate user interface may use a unique manufacturer-set password.

Security and mutual confidentiality between applications associated with the same node are supposed to be resolved at the higher layers of the protocol stack and are beyond the scope of this Recommendation.

5.1.6 Inter-domain bridging

The inter-domain bridge (IDB) function connects nodes of two domains. In Figure 5-7, application entities AE1 (service originator) and AE2 (service destination) are associated with nodes A1 and B2, respectively, of two domains. The communication path between nodes A1 and B2 goes through domain 1 and domain 2, and includes in-domain flows F1, F2 and the IDB function. Interfaces between nodes B1, A2 and the IDB are AE interfaces (A-interfaces, see clause 5.2.1). Communication paths routed through more than two domains operate in the same way.

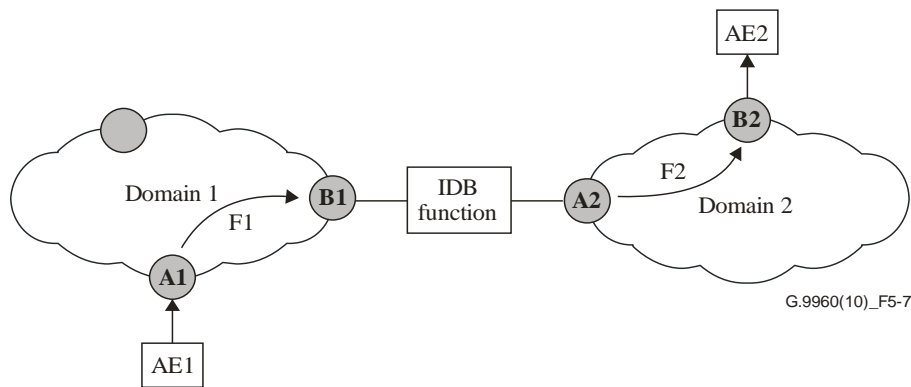

Figure 5-7 – Communication path between nodes of two different domains

The protocol reference model for inter-domain communications shown in Figure 5-7 is presented in Figure 5-8.

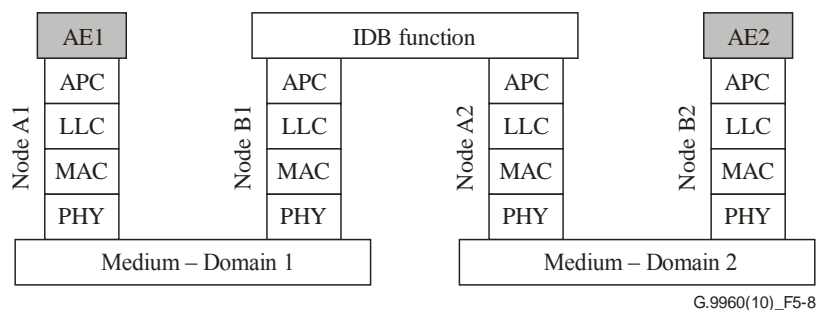

Figure 5-8 – Protocol stack of inter-domain communication

In the case that the APC is implemented as an Ethernet convergence sublayer, the IDB function can be implemented as a standard IEEE 802.1D transparent bridge. The means to avoid loops between multiple domains are for further study.

One case of inter-domain bridging relates to implementation of multimedia devices, which are equipped with more than one physical interface and, accordingly, can be connected to more than one domain. A scenario describing a two-media device is presented in Figure 5-9. The IDB connects the AE associated with the device to both domains (via nodes B1 and A2), and provides inter-domain connection (between nodes B1 and A2, similar to the one presented in Figure 5-7). The IDB interfaces to nodes B1 and A2 as an AE, and also bridges the AE to either or both of these nodes.

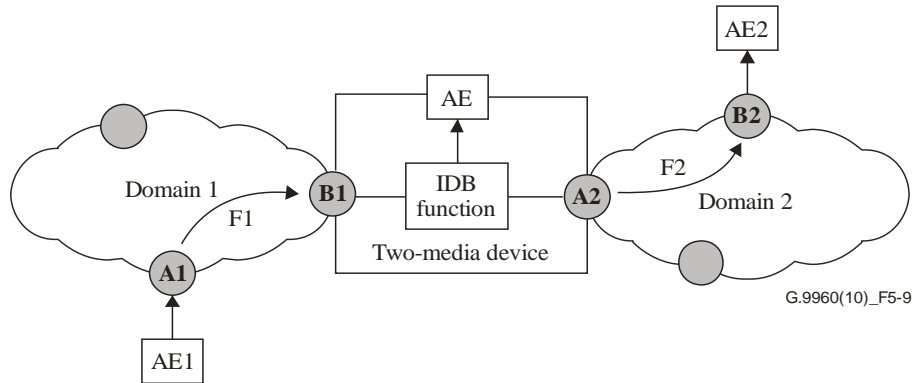

Figure 5-9 – Example of communication with a two-media (domain) device

The protocol reference model corresponding to Figure 5-9 is presented in Figure 5-10. It assumes a vendor-proprietary interface between the IDB and the AE. However, a standard interface like IEEE 802.3 can also be used.

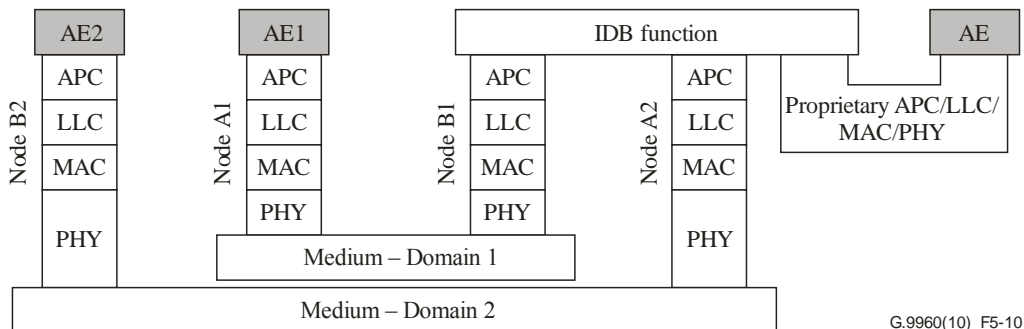

Figure 5-10 – Protocol stack of inter-domain communication

5.1.6.1 End-to-end QoS for multi-domain connections

The end-to-end QoS requirements are defined by priority level (in case of priority-based QoS), or by traffic parameters such as data rate and latency (for parameterized QoS). See clause 5.1.4. In both cases, to meet end-to-end requirements, requirements are imposed on in-domain flows forming the connection and on the IDB. In Figure 5-7, the end-to-end QoS requirements for the service routed between nodes A1 and B2 determine QoS requirements for flow F1, carrying the service inside domain 1, and for flow F2, carrying the service inside domain 2, and for the delay introduced by the IDB.

In the case of prioritized QoS, the end-to-end QoS requirements can be met if the IDB conveys priority requirements, so that the priority level applied to flow F1 in domain 1 corresponds to the priority level applied to flow F2 in domain 2. In the same way, prioritized QoS shall be supported for situations where the route for delivery of traffic between two nodes includes more than two domains.

In the case of parameterized QoS, the end-to-end QoS parameters shall be distributed between in-domain flows and the IDBs. The rules of distribution of end-to-end QoS parameters between multiple domains are for further study.

The IDB throughput shall be higher than the maximum throughput available in either of the domains connected by the IDB. The delay introduced by the IDB should be minimized (the maximum allowed values are for further study). The maximum number of IDBs in the path may be limited for certain service types.

Other parameters of the IDB functionality are vendor discretionary.

5.1.6.2 Security in multi-domain connections

For a multi-domain home network, secure operation is achieved by setting all its domains to secure mode. Communications between secure and non-secure domains shall not be allowed, unless special security measures are provided by the IDB (on higher protocol levels). These measures are beyond the scope of this Recommendation, as are security measures protecting the IDB from outside intrusion (i.e., when the intruder is one of the AEs connected to the IDB).

5.2 Reference models

5.2.1 Protocol reference model of a home network transceiver

The protocol reference model of a home network transceiver is presented in Figure 5-11. It includes three main reference points: application interface (A-interface), physical medium-independent interface (PMI), and medium-dependent interface (MDI). Two intermediate reference points, $x1$ and $x2$, are defined in the data link layer, and two other intermediate reference points, α and δ , are defined in the PHY layer (Figure 5-11).

The MDI is a physical interface defined in terms of the physical signals transmitted over a specific medium (see clause 7.2) and mechanical connection to the medium.

The PMI interface is both medium independent and application independent. It is defined in clause 5.2.2.2 as a functional interface, in terms of functional flows and logical signals.

The A-interface is user application-protocol specific (e.g., Ethernet, IP). The functional description of the A-interface is presented in clause 5.2.2.1.

All intermediate reference points are independent of the type of medium and are defined as functional (logical) interfaces in terms of the functional flows and logical signals.

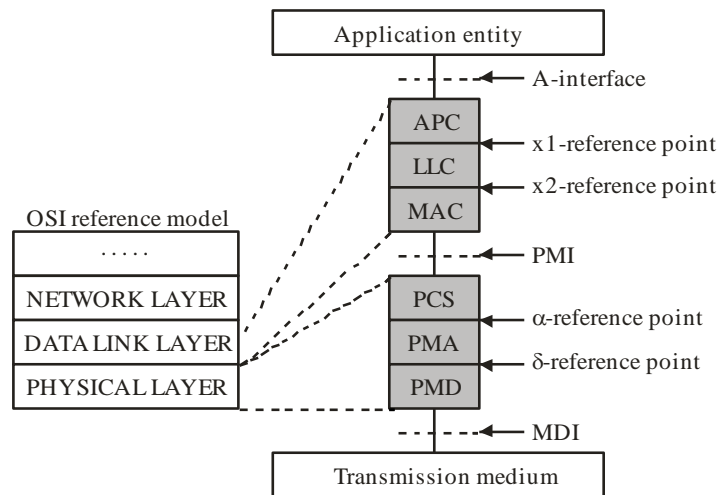

G.9960(10)_F5-11

- APC Application protocol convergence
- LLC Logical link control
- MAC Medium access control
- PCS Physical coding sub-layer
- PMA Physical medium attachment
- PMD Physical medium dependent
- PMI Physical medium-independent interface
- MDI Medium-dependent interface

Figure 5-11 – Protocol reference model of a home network transceiver

The application protocol convergence (APC) sublayer provides an interface with the application entity (AE), which operates with an application-specific protocol, such as Ethernet. The APC also provides the data rate adaptation between the AE and the home network transceiver.

The logical link control (LLC) sublayer coordinates transmission of nodes in accordance with requests from the domain master. In particular, it is responsible for establishing, managing, resetting and terminating all connections of the node inside the domain. The LLC also facilitates quality of service (QoS) constraints of the flow, defined for its various connections.

The MAC sublayer controls access of the node to the medium using various medium access protocols.

The PCS provides data rate adaptation (data flow control) between the MAC and PHY and encapsulates transmit media access control protocol data units (MPDUs) into the PHY frame and adds PHY-related control and management overhead. The PMA provides encoding of PHY frame content for transmission over the medium. The PMD modulates and demodulates PHY frames for transmission over the medium using orthogonal frequency division multiplexing (OFDM). By implementation, the PMD may include medium-dependent adaptors for different media, including frequency shifting for passband transmission.

The layers above the data link layer (above the A-interface) are beyond the scope of this Recommendation. Management functions are not presented in Figure 5-11.

5.2.2 Interfaces – functional description

This clause contains the functional description of the ITU-T G.9960 transceiver interfaces (A, PMI, and MDI) in terms of signal flows exchanged between corresponding entities. The description does not imply any specific implementation of the transceiver interfaces.

5.2.2.1 A-interface

The A-interface is described in terms of primitives exchanged between the AE and the DLL. There are six general types of A-interface primitives, as shown in Table 5-3. Each primitive type may consist of one or more primitives, related to control or data, respectively. Data primitives represent the data path of the A-interface, while control primitives represent the control path. The format of the

application data primitives (ADPs) is application specific, determined by the AE. See [ITU-T G.9961] for further description of the application protocol convergence (APC) specific sublayer.

Table 5-3 – A-interface primitive type summary

Primitive type	Direction	Description
AIF_DATA.REQ	AE → DLL	Data from AE to DLL
AIF_DATA.CNF	DLL → AE	Data confirmation from DLL to AE
AIF_DATA.IND	DLL → AE	Data from DLL to AE
AIF_CTRL.REQ	AE → DLL	Control from AE to DLL
AIF_CTRL.CNF	DLL → AE	Control confirmation from DLL to AE
AIF_CTRL.IND	DLL → AE	Control from DLL to AE

5.2.2.2 Physical medium-independent interface (PMI)

The PMI is described in terms of primitives exchanged between the DLL and PHY layer presented in Table 5-4; the direction of each primitive flow indicates the entity originating the primitive. Both transmit and receive data primitives are exchanged in MAC protocol data units (MPDUs).

Table 5-4 – PMI primitive description

Primitive	Direction	Description
PMI_DATA.REQ	DLL → PHY	Flow of MPDUs for transmission
PMI_CTRL-RxDis.REQ	DLL → PHY	Disables receive of PHY frames
PMI_DATA.IND	PHY → DLL	Flow of received MPDUs
PMI_CTRL-ERR.IND	PHY → DLL	Error primitive that accompanies an MPDU received with errors
PMI_CTRL-CRS.IND	PHY → DLL	Carrier sense primitive
RX ENABLE	DLL → PHY	Enable receive function in the PHY layer
NOTE – Primitives presented in this table are exclusively for descriptive purposes and do not imply any specific implementation.		

5.2.2.3 Medium-dependent interface (MDI)

Functional characteristics of the MDI are described by two signal flows:

- transmit signal (TX DATA) is the flow of frames transmitted on to the medium;
- receive signal (RX DATA) is the flow of frames received from the medium.

5.2.3 Functional model of a home network transceiver

The functional model of a home network transceiver is presented in Figure 5-12. It addresses nodes without extended capabilities, as well as nodes with extended capabilities such as domain master, and relaying (including DAP), which differ by their MAC, LLC and upper layer functionalities.

The PMD function depends on the medium on which the transceiver operates. It can be configured for baseband or passband operation. The PCS provides data rate adaptation (data flow control) between the MAC and the PHY and encapsulates transmit MAC protocol data units (MPDUs) into PHY frames. The transmit PHY frame is further encoded in the PMA to meet the corresponding PMD. The functionality of the PCS, and the PMA is the same for any medium, but their parameters are medium-specific. By appropriate parameter settings, any node can be configured to operate on any type of wiring in both baseband and passband modes.

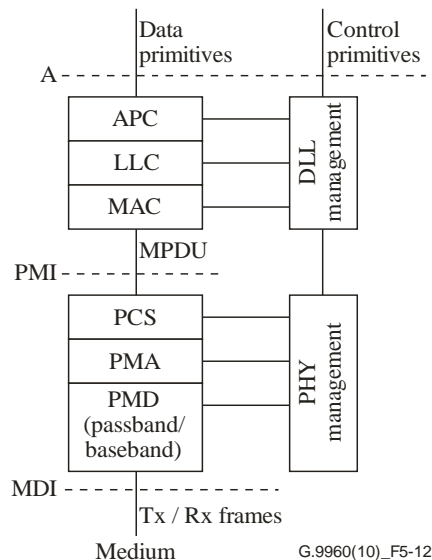

Figure 5-12 – Functional model of a home network transceiver

The detailed description of the functional model of the PHY layer is presented in clause 7.1. The DLL is specified in [ITU-T G.9961].

5.2.4 Bit ordering convention

A block of data composed of multiple octets shall be ordered by octet numbers in ascending order: "octet 0" for the first octet, "octet 1" for the second octet, and so on. If a block of data is segmented into multiple fields, the size of each field shall be expressed in terms of bits. The field is not necessarily an integer number of octets. The location of each field within a block of data shall be described as follows:

- The octets of an N -octet data block are ordered with numbers from 0 (first octet) to $N-1$ (last octet).
- The block is divided into non-overlapping groups of octets. Each group contains an integer number of consecutive octets, numbered from J to $J+V-1$, where V is the size of the group, and is described as a bit string with "bit 0", the LSB of the octet with the smallest number (J), and "bit ($8 \times V - 1$)", the MSB of the octet with the largest number ($J+V-1$).
- Each group is divided into one or more fields, where the boundaries of each field are determined by the LSB and the MSB of the bits of the group that contains this field.

Any block of data or part of it shall be passed over the protocol stack with the octet having the smallest number, i.e., octet 0 shall be the first octet of the block to be passed. Within each group of octets, LSB (bit 0) of each octet shall be passed first.

Table 5-5 shows an example of a field description used throughout this Recommendation. The "Octet" column represents the octet numbers for a group of octets to which a specific field belongs, and the "Bits" column represents the bit location within this group of octets. In the presented example, there are 4 groups of octets:

- Group 1 = Octet 0, fields A, B, C, D
- Group 2 = Octets 1 and 2, fields E, F
- Group 3 = Octet 3, field G
- Group 4 = Octets 4 to 7, field H.

Figure 5-13 illustrates a mapping of these fields on to corresponding octets based on the example given in Table 5-5.

Table 5-5 – An example of field description

Field	Octet	Bits	Description
A	0	[2:0]	...
B		[3]	...
C		[4]	...
D		[7:5]	...
E	1 and 2	[1:0]	...
F		[15:2]	...
G	3	[7:0]	...
H	4 to 7	[31:0]	...

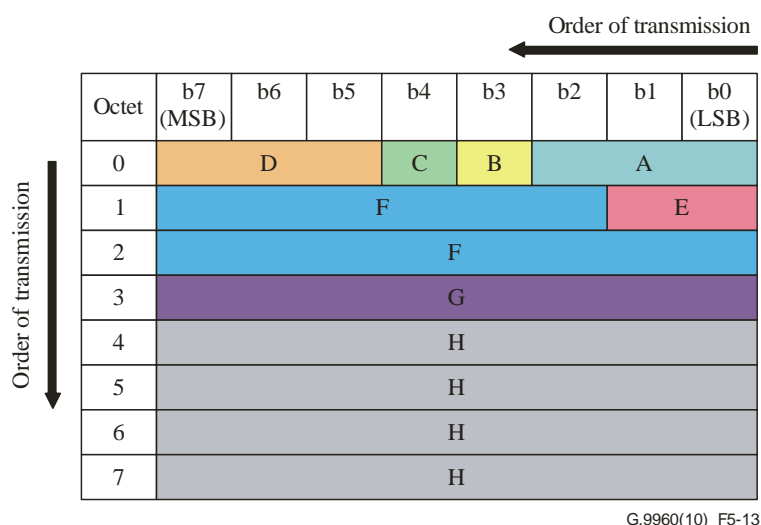

Figure 5-13 – An example of mapping fields on to groups of octets

5.3 Management-plane reference model

Figure 5-14 illustrates data-, control-, and management-plane reference models for an ITU-T G.9960/G.9961 transceiver. Details of data- and control-plane reference models are shown in clause 5.2. The Q-interface provides the interface between the network management systems (NMS) and the node management entity (NME) at a node. The definition of parameters at the Q-interface and the transport of the management instrumentation over the Q-interface are outside the scope of this Recommendation.

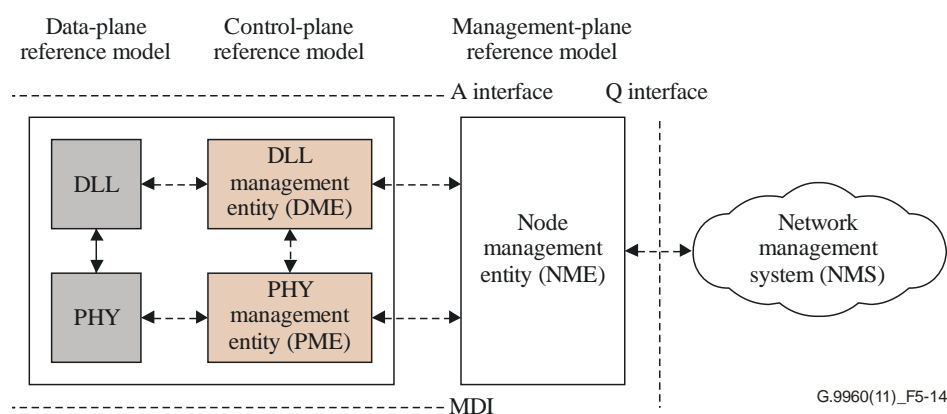

Figure 5-14 – Management-plane reference model

6 Profiles

Profiles are intended to specify nodes with significantly different levels of complexity and functionality. For every domain type, a more complex profile is a superset of less complex profile and shall interoperate with that profile. A node shall be classified into particular profiles according to its degree of complexity and functionality. For compliance with this Recommendation, a node is required to support one profile, at a minimum. Profiles are summarized in Table 6-1.

Table 6-1 – Profiles

Profile name	Domain type	Valid bandplans (Note 1)
Low-complexity profile	Power-line baseband	25 MHz-PB
Standard profile	Power-line baseband	50 MHz-PB, 100 MHz-PB
	Telephone-line baseband (Note 2)	50 MHz-TB, 100 MHz-TB, 200 MHz-TB
	Coax baseband	50 MHz-CB, 100 MHz-CB, 200 MHz-CB
	Coax RF	50 MHz-CRF, 100 MHz-CRF, 200 MHz-CRF
NOTE 1 – In order to be compliant with a given profile, at least one bandplan shall be implemented. The 200 MHz-CRF bandplan is applicable to Annex C only.		
NOTE 2 – Telephone-line baseband profile is also applicable to any other pair-based copper cable (e.g. Cat5)		

6.1 Low-complexity profile (LCP)

Table 6-2 describes the valid values of parameters for the low-complexity profile (LCP) that differentiate it from other profiles.

Table 6-2 – Valid parameters for the low-complexity profile

Parameters	Description
EVM	See clause 7.2.4
BAT	Type 0, Type 1, Type 2, and Type 3 predefined BATs
FEC rate	Rate ½
FEC block size	120 bytes (Payload)

6.2 Standard profile

Table 6-3 describes the valid values of parameters for the standard profile that differentiate it from other profiles.

Table 6-3 – Valid parameters for the standard profile

Parameters	Description
EVM	See clauses 7.2.4 and C.2.3.4
BAT	Type 0, Type 1, Type 2 and Type 3 predefined BATs. Supports at least a total of 8 simultaneous runtime BATs assuming no grouping (including transmit and receive BATs)
FEC rate	Rate ½, 2/3, 5/6, 16/18, and 20/21

FEC block size	120 and 540 bytes (Payload)
----------------	-----------------------------

7 Physical layer specification

7.1 Medium independent specification

7.1.1 Functional model of the PHY

The functional model of the PHY is presented in Figure 7-1. The PMI and MDI are, respectively, two demarcation reference points between the PHY and MAC and between the PHY and the transmission medium. Internal reference points δ and α show separation between the PMD and PMA, and between the PCS and PMA, respectively.

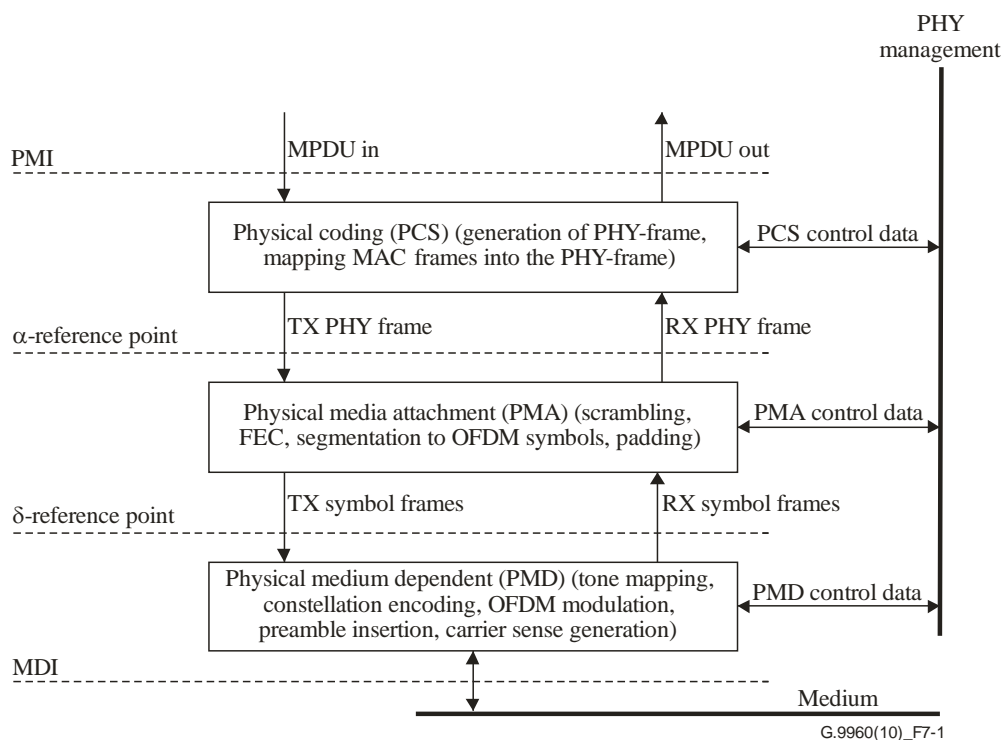

Figure 7-1 – Functional model of the PHY

In the transmit direction, data enters the PHY from the MAC via the PMI in blocks of bytes called MAC protocol data units (MPDUs). The incoming MPDU is mapped into a PHY frame in the PCS, scrambled and encoded in the PMA, modulated in the PMD, and transmitted over the medium using OFDM modulation with relevant parameters. In the PMD, a preamble is added to assist synchronization and channel estimation in the receiver.

In the receive direction, frames entering from the medium via the MDI are demodulated and decoded. The recovered MPDUs are forwarded to the MAC via the PMI. The recovered PHY-frame headers are processed in the PHY to extract the relevant frame parameters specified in clause 7.1.2.3.

7.1.2 Physical coding sublayer (PCS)

The functional model of the PCS is presented in Figure 7-2. It is intended to describe in more detail the PCS functional block presented in Figure 7-1.

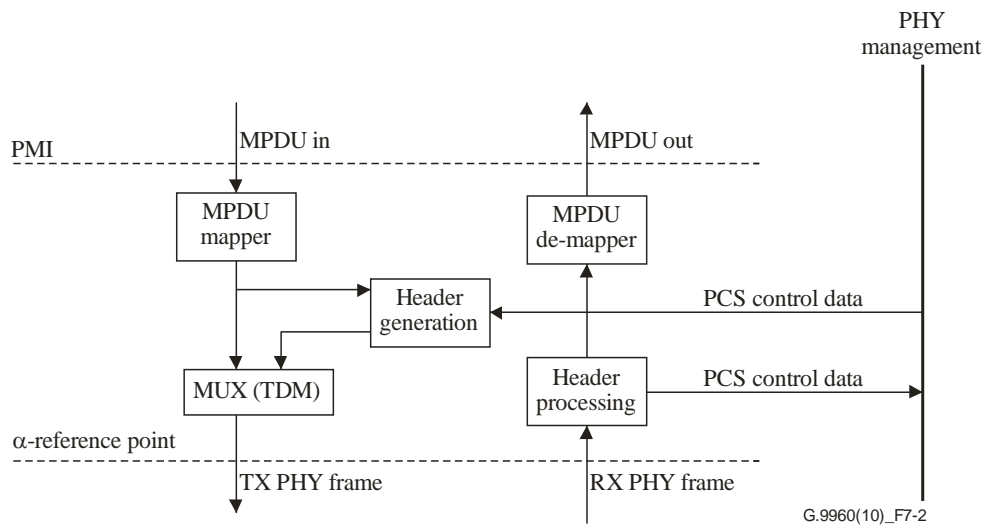

Figure 7-2 – Functional model of PCS

In the transmit direction, the incoming MPDU is mapped into a payload field of a PHY frame (clause 7.1.2.1) as described in clause 7.1.2.2. The PHY-frame header (clause 7.1.2.3) is then added to form a TX PHY frame. The TX PHY frame is passed across the α -reference point for further processing in the PMA.

In the receive direction, the decoded PHY-frame payload and header are processed, and originally transmitted MPDUs are recovered from the payloads of received PHY frames and submitted to the PMI. Relevant control information conveyed in the PHY-frame header is processed and submitted to the PHY management entity.

7.1.2.1 PHY frame

The format of the PHY frame is presented in Figure 7-3. The PHY frame at the α -reference point includes a header, and a payload. The preamble and additional channel estimation (ACE) symbols are added to the PHY frame in the PMD, as described in clauses 7.1.4.5 and 7.1.4.2.5, respectively. The preamble does not carry any user or management data and is intended for synchronization and initial channel estimation.

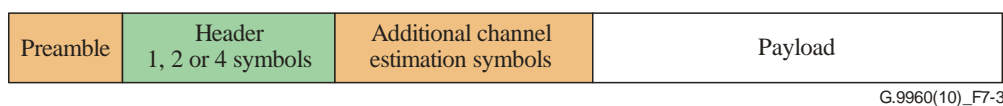

Figure 7-3 – Format of the PHY frame

The PHY-frame header and payload shall each contain an integer number of OFDM symbols.

The PHY-frame header always fits into an integer number of symbols and is transmitted using a single predefined set of modulation and coding parameters (see clause 7.1.3.4).

The presence of ACE symbols is frame type dependent (see clause 7.1.2.3).

The length of the payload may vary from frame to frame; the payload may be of zero length. For the payload, different coding parameters and bit loading can be used in different frames, depending on the channel/noise characteristics and QoS requirements.

The types of PHY frames used in this Recommendation are summarized in Table 7-1.

Table 7-1 – PHY frame types

Frame type	Header	Payload	Description	Reference
MAP/RMAP	√	√	A frame carrying the MAP or RMAP; the payload contains an MPDU	Clause 7.1.2.3.2.1, clause 8.8 of [ITU-T G.9961]
MSG	√	√	A frame carrying user data or management data or both; the payload contains an MPDU	Clause 7.1.2.3.2.2
ACK	√	None	An acknowledgement frame; the relevant ARQ data is communicated in the header	Clause 7.1.2.3.2.3
RTS	√	None	A request-to-send frame; the relevant data is communicated in the header	Clause 7.1.2.3.2.4
CTS	√	None	A clear-to-send frame; the relevant data is communicated in the header	Clause 7.1.2.3.2.5
CTMG	√	None	A frame carrying a short control message	Clause 7.1.2.3.2.6
PROBE	√	√	A frame carrying probe symbols in its payload	Clause 7.1.2.3.2.7, clause 7.1.3.6
ACKRQ	√	None	An ACK retransmission request frame; the relevant data is communicated in the header	Clause 7.1.2.3.2.8
BMSG	√	√	A bidirectional MSG frame	Clause 7.1.2.3.2.9, clause 8.3.7 of [ITU-T G.9961]
BACK	√	√	A bidirectional ACK frame	Clause 7.1.2.3.2.10, clause 8.3.7 of [ITU-T G.9961]
ACTMG	√	None	An acknowledgment frame for a CTMG frame	Clause 7.1.2.3.2.11
FTE	√	Note	Frame type extension	Clause 7.1.2.3.2.16
NOTE – Whether a payload is present or not depends on the definition of the extended frame type.				

7.1.2.2 MPDU mapping

MPDUs are passed to the PHY as an ordered sequence of bytes that are processed as an ordered string of bits from LSB to MSB within each byte. The first bit of the MPDU shall be the first transmitted bit of the payload.

7.1.2.3 PHY-frame header

The core part of the PHY-frame header is PHY_H bits long (see clause 7.1.3.2.2). It is transmitted over D (see clause 7.1.3.5.2) consecutive OFDM symbols, where D may be either 1 or 2. The core part of the PHY-frame header is composed of a common part and a variable part. The common part contains fields that are common for all PHY-frame types. The variable part contains fields according to the PHY-frame type. The PHY-frame type is indicated by the FT field. The PAD fields fit the length of the header of different PHY frame-types to the standard value of PHY_H bits. The content of the core part is protected by the 16-bit header check sequence (HCS).

The fields of the core part of the PHY-frame header are defined in Table 7-2.

Table 7-2 – Core part of the PHY-frame header

Field	Octet	Bits	Description	Reference
				Common part
FT	0	[3:0]	Frame type	Clause 7.1.2.3.1.1
DOD		[7:4]	Domain ID	Clause 7.1.2.3.1.2
SID	1	[7:0]	DEVICE_ID of the source node	Clause 7.1.2.3.1.3
DID	2	[7:0]	DEVICE_ID, MULTICAST_ID or BROADCAST_ID of the destination node(s)	Clause 7.1.2.3.1.4
MI	3	[0]	Multicast indication identifying whether the DID is a unicast or multicast destination	Clause 7.1.2.3.1.5
DRI		[1]	Duration indication identifying whether FTSF starts with a 16-bit duration field	Clause 7.1.2.3.1.6
EHI		[2]	Extended header indication	Clause 7.1.2.3.1.7
HSI		[3]	Header segmentation indication	Clause 7.1.2.3.1.8
Reserved		[7:4]	Reserved by ITU-T (Note)	
				Variable part
FTSF	4 to 18	[119:0]	Frame-type specific field	Clause 7.1.2.3.2
				Common part
HCS	19 and 20	[15:0]	Header check sequence	Clause 7.1.2.3.1.9
NOTE – Bits that are reserved by ITU-T shall be set to zero by the transmitter and ignored by the receiver.				

Depending on the value of the extended header indication (EHI) field in the core part of the PHY-frame header, the PHY-frame header may be extended by additional PHY_H bits that are transmitted over an additional *D* consecutive OFDM symbols. If the EHI bit is set to one, additional PHY_H bits representing the extended part of the PHY-frame header are appended to the end of the core part of the PHY-frame header. The extended part of the PHY-frame header shall be encoded and segmented exactly the same way as the core part, as described in clauses 7.1.3.4 and 7.1.3.5.2. The content of the extended part is protected by the 16-bit extended header check sequence (E_HCS).

The core part and the extended part of the PHY-frame header shall be transmitted over separate OFDM symbols, as illustrated in Figure 7-4.

(1) PHY-frame header core part transmitted over one OFDM symbol, i.e., HSI = 0 (D = 1), EHI = 0

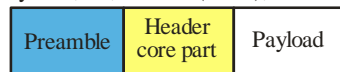

(2) PHY-frame header core part transmitted over two OFDM symbols, i.e., HSI = 1 (D = 2), EHI = 0

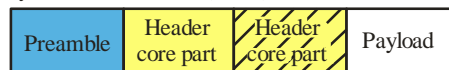

(3) PHY-frame header core and extended parts, each transmitted over one OFDM symbol, i.e., HSI = 0 (D = 1), EHI = 1

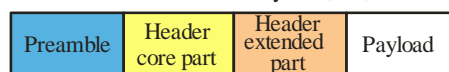

(4) PHY-frame header core and extended parts, each transmitted over two OFDM symbols, i.e., HSI = 1 (D = 2), EHI = 1

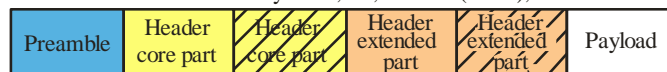

G.9960(10)_F7-4

Figure 7-4 – Allowed cases of PHY-frame header transmissions

7.1.2.3.1 Common part fields

7.1.2.3.1.1 Frame type (FT)

The Frame type (FT) field is a 4-bit field that indicates the type of PHY frame.

Table 7-3 describes the PHY-frame types.

Table 7-3 – PHY-frame types

Type	Value (b ₃ b ₂ b ₁ b ₀)	Description	Reference
MAP/RMAP	0000	MAP/RMAP frame	Clause 7.1.2.3.2.1
MSG	0001	Data and management frame	Clause 7.1.2.3.2.2
ACK	0010	ACK control frame	Clause 7.1.2.3.2.3
RTS	0011	RTS control frame	Clause 7.1.2.3.2.4
CTS	0100	CTS control frame	Clause 7.1.2.3.2.5
CTMG	0101	Short control frame	Clause 7.1.2.3.2.6
PROBE	0110	PROBE frame	Clause 7.1.2.3.2.7
ACKRQ	0111	ACK retransmission request frame	Clause 7.1.2.3.2.8
BMSG	1000	Bidirectional MSG frame; contains data and management frames in the payload and ACK	Clause 7.1.2.3.2.9
BACK	1001	Bidirectional ACK frame; contains ACK and data and management frames in the payload	Clause 7.1.2.3.2.10
ACTMG	1010	Acknowledgment for CTMG frame	Clause 7.1.2.3.2.11
Reserved	1011 to 1110	Reserved by ITU-T	Clause 7.1.2.3.2.12 to clause 7.1.2.3.2.15
FTE	1111	Frame type extension; This frame type is a pointer to a set of additional frame types	Clause 7.1.2.3.2.16

7.1.2.3.1.2 Domain ID (DOD)

The DOD field shall contain the domain ID to which the source and destination devices of the PHY frame belong. It shall be represented as a 4-bit unsigned integer with valid values in the range from 0 to 15. Value 0 is a special value reserved for inter-domain communication (see clause 8.14.6.1.2 in [\[ITU-T G.9961\]](#)).

7.1.2.3.1.3 Source ID (SID)

The SID field shall contain the DEVICE_ID assigned to the source node of the PHY frame during its registration. It shall be represented as an 8-bit unsigned integer with valid values in the range from 0 to 251. Value 0 is a special value that shall be used by a node attempting to join the domain. Value 251 is a special value reserved for inter-domain communication (see clause 8.14.6.1 in [\[ITU-T G.9961\]](#)).

7.1.2.3.1.4 Destination ID (DID)

The DID field shall contain the value that identifies the destination node(s) of the PHY frame. It shall be represented as an 8-bit unsigned integer with valid values in the range from 0 to 250.

7.1.2.3.1.5 Multicast indication (MI)

If the multicast indication (MI) bit is set to zero, the DID field shall contain the DEVICE_ID of the destination node (for unicast transmission). If the MI bit is set to one, the DID field shall contain a MULTICAST_ID or BROADCAST_ID of the destination nodes.

7.1.2.3.1.6 Duration indication (DRI)

If the DRI bit is set to one, the FTSF shall start with a duration field. If this bit is set to zero, the PHY frame shall not contain any payload (i.e., contains only preamble and PHY-frame header).

The duration field contains the duration of a single PHY frame or PHY frame sequence. It shall be represented as a 16-bit unsigned integer with valid values in steps of 0.25 μ s. It shall be the smallest integer larger than or equal to the actual duration. The duration field is defined separately depending on the frame type. If a node detects a PHY frame with unknown frame type, the node shall assume for its virtual carrier sense that the channel will be occupied for that duration. After that time there shall be an inter-frame gap equal to T_{IFG_MIN} .

Table 7-4 – Value of DRI for different frame types

Frame type	Value of DRI
MAP/RMAP	one
MSG	one
ACK	zero
RTS	one
CTS	one
PROBE	one
ACKRQ	zero
BMSG	one
BACK	one
CTMG	zero
ACTMG	zero
FTE	zero or one

7.1.2.3.1.7 Extended header indication (EHI)

If the EHI field is set to one, the PHY frame header shall contain $2 \times \text{PHY}_H$ information bits. The additional PHY_H information bits of the extended part of the PHY-frame header are specified in clause 7.1.2.3.3. If the EHI field is set to zero, the PHY-frame header shall contain PHY_H information bits. The EHI field shall be set according to the frame type as shown in Table 7-5.

Table 7-5 – Value of EHI for different frame types

Frame type	Value of EHI
MAP/RMAP	zero
MSG	zero
ACK	zero or one
RTS	zero
CTS	zero

Table 7-5 – Value of EHI for different frame types

Frame type	Value of EHI
PROBE	zero
ACKRQ	zero
BMSG	zero or one
BACK	zero or one
CTMG	zero or one
FTE	zero or one
ACTMG	zero

7.1.2.3.1.8 Header segmentation indication (HSI)

The HSI field shall be set to the same value as the header segmentation field in the TXOP descriptor extension in the MAP (see Table 8-65 in [ITU-T G.9961]).

7.1.2.3.1.9 Header check sequence (HCS)

The HCS field is intended for PHY-frame header verification. It is a 16-bit cyclic redundancy check (CRC) and shall be computed over all the fields of the PHY-frame header in the order they are transmitted, starting with the LSB of the first field of the PHY frame header (FT) and ending with the MSB of the last field of the FTSF.

The HCS shall be computed using the following generator polynomial of degree 16:

$$G(x) = x^{16} + x^{12} + x^5 + 1$$

The value of the HCS shall be the remainder after the contents (treated as a polynomial where the first input bit is associated with the highest degree, X^{PHY_H-17} , where PHY_H is the header length in bits, and the last input bit is associated with X^0) of the calculation field is multiplied by x^{16} and then divided by $G(x)$.

The HCS field shall be transmitted starting with the coefficient of the highest order term.

7.1.2.3.2 Variable part fields

This clause details the frame-type specific field (FTSF), a variable part of the PHY-frame header fields separately defined for each PHY-frame type.

7.1.2.3.2.1 MAP and RMAP PHY-frame type specific fields

Table 7-6 lists the PHY-frame header fields which are specific to the MAP and RMAP frame type.

Table 7-6 – MAP and RMAP PHY-frame type specific fields

Field	Octet	Bits	Description	Reference
MAP_DUR	0 and 1	[15:0]	Duration for MAP frame	Clause 7.1.2.3.2.1.1
NTR	2 to 5	[31:0]	Network time reference	Clause 7.1.2.3.2.1.2
CYCSTART	6 to 9	[31:0]	MAC cycle start time	Clause 7.1.2.3.2.1.3
RCMSS	10 and 11	[11:0]	RCM section size	Clause 7.1.2.3.2.1.4
SI		[15-12]	Scrambler initialization	Clause 7.1.2.3.2.1.5

Table 7-6 – MAP and RMAP PHY-frame type specific fields

Field	Octet	Bits	Description	Reference
BLKSZ	12	[1:0]	Block size of FEC codeword for MAP frame payload	Clause 7.1.2.3.2.1.6
REP		[4:2]	Number of repetitions for encoding payload	Clause 7.1.2.3.2.1.7
FCF		[7:5]	FEC concatenation factor	Clause 7.1.2.3.2.1.8
BNDPL	13	[2:0]	Bandplan	Clause 7.1.2.3.2.1.9
MAP_TYPE		[3]	MAP type	Clause 7.1.2.3.2.1.10
RMAPI		[4]	RMAP indication	Clause 7.1.2.3.2.1.11
Reserved		[7:5]	Reserved by ITU-T (Note)	
NUM_HOPS	14	[3:0]	Number of hops from domain master	Clause 7.1.2.3.2.1.12
Reserved		[7:4]	Reserved by ITU-T (Note)	

NOTE – Bits that are reserved by ITU-T shall be set to zero by the transmitter and ignored by the receiver.

7.1.2.3.2.1.1 Duration for MAP frame (MAP_DUR)

The MAP_DUR field shall contain the transmission time of the MAP frame.

7.1.2.3.2.1.2 Network time reference (NTR)

The NTR field shall contain the time of the first sample of the first OFDM symbol (see Figure 7-24) of the preamble of a MAP or RMAP frame that is sent according to the domain master's transmit clock with a resolution of 10 ns. It is used for synchronizing nodes to the domain master transmit clock. It shall be represented as a 32-bit unsigned integer. The NTR value shall use modulo 2^{32} arithmetic.

If a node other than the domain master transmits the frame, it shall use the best estimate of the domain master's NTR (see clause 7.1.6.2).

7.1.2.3.2.1.3 MAC cycle start time (CYCSTART)

The CYCSTART field shall contain the start time of the next MAC cycle. It shall be represented as a 32-bit unsigned integer. It shall be based on the domain master's transmit clock with a resolution of 10 ns. The value of CYCSTART in a MAC cycle shall be equal to the value of CYCSTART in the previous MAC cycle plus the MAC cycle duration, indicated in the MAP header (see clause 8.8.3 of [ITU-T G.9961]).

All MAP/RMAP frames transmitted during the MAC cycle (n) shall contain the same CYCSTART value that defines the starting point of the MAC cycle ($n + 1$).

The CYCSTART value shall use modulo 2^{32} arithmetic.

7.1.2.3.2.1.4 RCM section size (RCMSS)

The RCMSS field shall contain the size of the repetition block, B , used in the MAP frame (see clause 7.1.3.3.1). It shall be represented as a 12-bit unsigned integer with valid values in the range from 14 to 4094.

7.1.2.3.2.1.5 Scrambler initialization (SI)

The SI field shall contain the value that was used by the domain master to initialize the scrambler for this frame. It is a 4-bit field $C_4C_3C_2C_1$ as described in clause 7.1.3.1.

7.1.2.3.2.1.6 Block size (BLKSZ)

The BLKSZ field shall contain the information block size of the FEC codeword that is used for the payload of the MAP frame. It is a 2-bit field that shall be coded as shown in Table 7-7.

Table 7-7 – Interpretation of the BLKSZ field

BLKSZ value (b_1b_0)	Interpretation
00	For the 120-byte information block size used for payload
01	For the 540-byte information block size used for payload
10 and 11	Reserved by ITU-T

7.1.2.3.2.1.7 Repetitions (REP)

The REP field shall contain the number of repetitions that were used for encoding the payload in the MAP frame. It is a 3-bit field that shall be coded as shown in Table 7-8.

Table 7-8 – Repetitions field allowed values

REP value ($b_7b_6b_5$)	Interpretation (N_{REP})
000	Reserved by ITU-T
001	1 (no repetitions)
010	2
011	3
100	4
101	6
110	8
111	Reserved by ITU-T

7.1.2.3.2.1.8 FEC concatenation factor (FCF)

The FCF field shall contain the FEC concatenation factor. It is a 3-bit field that shall be coded as shown in Table 7-9.

Table 7-9 – FEC concatenation factor (FCF) allowed values

FCF value ($b_2b_1b_0$)	H	z
000	1	0
001	Reserved by ITU-T	Reserved by ITU-T
010	2	0
011	2	1
100	4	0
101	4	1
110	4	2
111	4	3

7.1.2.3.2.1.9 Bandplan (BNDPL)

The BNDPL field shall contain the identifier for the bandplan used by the node. It is a 3-bit field that shall be coded as shown in Table 7-10.

Table 7-10 – Bandplan identifier

BNDPL value (b ₇ b ₆ b ₅)	Description
000	Reserved by ITU-T
001	25 MHz
010	50 MHz
011	100 MHz
100	200 MHz
101 to 111	Reserved by ITU-T

7.1.2.3.2.1.10 MAP type (MAP_TYPE)

If the MAP_TYPE bit is set to zero, the default MAP (MAP-D) or default RMAP (RMAP-D) frame shall be used for transmission using predefined BAT Type 1 for the MAP/RMAP frame payload. If the MAP_TYPE bit is set to one, the active MAP (MAP-A) or active RMAP (RMAP-A) frame shall be used for transmission using predefined BAT Type 2 for the MAP/RMAP frame payload.

The MAP-D or RMAP-D frame shall only use an FEC block size of 120 bytes.

For all MAP types, the MAP/RMAP frame shall use the default guard interval (N_{GI-DF}), rate ½ FEC coding, and the payload repetition scheme as specified in clause 7.1.3.3.1.

7.1.2.3.2.1.11 RMAP indication (RMAPI)

If the RMAPI bit is set to zero, the MAP frame shall be used for transmission. If the RMAPI bit is set to one, the RMAP frame shall be used for transmission.

7.1.2.3.2.1.12 Number of hops from domain master (NUM_HOPS)

The NUM_HOPS field shall contain the number of hops that the node sending this RMAP frame is from the domain master. A value of 0 shall indicate that the node receives PHY frames from the domain master directly; a value of 1 shall indicate that the node is two hops from the domain master; and so on.

7.1.2.3.2.2 MSG PHY-frame type specific fields

Table 7-11 lists the PHY-frame header fields which are specific to the MSG frame type.

Table 7-11 – MSG PHY-frame type specific fields

Field	Octet	Bits	Description	Reference
MSG_DUR	0 and 1	[15:0]	Duration for MSG frame	Clause 7.1.2.3.2.2.1
BLKSZ	2	[1:0]	Block size of FEC codeword for MSG frame payload	Clause 7.1.2.3.2.2.2
FEC_RATE		[4:2]	FEC coding rate for MSG frame payload	Clause 7.1.2.3.2.2.3
REP		[7:5]	Number of repetitions used for encoding the MSG frame payload	Clause 7.1.2.3.2.2.4

Table 7-11 – MSG PHY-frame type specific fields

Field	Octet	Bits	Description	Reference
FCF	3	[2:0]	FEC concatenation factor	Clause 7.1.2.3.2.2.5
SI		[6:3]	Scrambler initialization	Clause 7.1.2.3.2.2.6
MDET		[7]	Master is detected	Clause 7.1.2.3.2.2.7
BAT_ID	4	[4:0]	Bit allocation table identifier	Clause 7.1.2.3.2.2.8
BNDPL/GRP_ID		[7:5]	Bandplan identifier/subcarrier grouping identifier	Clause 7.1.2.3.2.2.9
GI_ID	5	[2:0]	Guard interval identifier	Clause 7.1.2.3.2.2.10
APSD_MAX-M		[7:3]	APSD_MAX-M of an MSG frame	Clause 7.1.2.3.2.2.11
CONNECTION_ID	6	[7:0]	Connection identifier	Clause 7.1.2.3.2.2.12
RPRQ	7	[1:0]	Reply required	Clause 7.1.2.3.2.2.13
BRSTCnt		[3:2]	Burst frame count	Clause 7.1.2.3.2.2.14
BEF		[4]	Burst end flag	Clause 7.1.2.3.2.2.15
AIFG_IND		[5]	AIFG indication	Clause 7.1.2.3.2.2.16
Reserved		[6]	Reserved	Reserved for use by ITU-T G.9963 (Note 1)
APSD_MAX-M-EXT Reserved		[7]	APSD_MAX-M extension Reserved	Clause 7.1.2.3.2.2.25 Reserved by ITU-T (Note 1)
ACE_SYM	8	[2:0]	Number of ACE symbols	Clause 7.1.2.3.2.2.17
CNN_MNGMT		[6:3]	Connection management	Clause 7.1.2.3.2.2.18
Reserved		[7]	Reserved	Reserved by ITU-T (Note 1)
BRURQ	9 and 10	[15:0]	Bandwidth reservation update request	Clause 7.1.2.3.2.2.19 (Note 2)
START_SSN	9 and 10	[15:0]	Start segment sequence number	Clause 7.1.2.3.2.2.20 (Note 3)
CURRTS	11	[6:0]	Current TS	Clause 7.1.2.3.2.2.21
BTXRQ		[7]	Request for bidirectional transmission	Clause 7.1.2.3.2.2.22
NUM_MACK_SLOTS	12	[2:0]	Number of Mc-ACK slots	Clause 7.1.2.3.2.2.23
ADVISED_WIN_SIZE		[7:3]	In connection establishment this field may specify advised window size.	Clause 7.1.2.3.2.2.24 (Note 4)
Reserved	13 and 14	[15:0]	Reserved	Reserved by ITU-T (Note 1)

NOTE 1 – Bits that are reserved by ITU-T shall be set to zero by the transmitter and ignored by the receiver.

NOTE 2 – The BRURQ field is defined when the START_SSN field is not defined (see Note 3).

NOTE 3 – The START_SSN field is defined only when CNN_MNGMT = 0001, CNN_MNGMT = 0011, CNN_MNGMT = 0101 or CNN_MNGMT = 0111. Otherwise, the meaning of this field is BRURQ.

Table 7-11 – MSG PHY-frame type specific fields

Field	Octet	Bits	Description	Reference
NOTE 4 – The ADVISED_WIN_SIZE field is defined only when CNN_MNGMT = 0101, otherwise these bits are reserved by ITU-T and shall be set to zero by the transmitter and ignored by the receiver.				

7.1.2.3.2.2.1 Duration for MSG frame (MSG_DUR)

For an MSG frame where Imm-ACK or one or more Mc-ACKs do not follow the MSG frame, the duration field shall contain the transmission time of the MSG frame.

For an MSG frame where Imm-ACK or one or more Mc-ACKs follow the MSG frame, the duration field shall contain the transmission time of the MSG frame plus the duration of the following AIFG. The MSG_DUR field shall not exceed 6 ms.

7.1.2.3.2.2.2 Block size (BLKSZ)

The BLKSZ field shall contain the information block size of the FEC codeword that is used for the payload of the MSG frame. It is a 2-bit field that shall be coded as shown in Table 7-7.

7.1.2.3.2.2.3 FEC coding rate (FEC_RATE)

The FEC_RATE field shall contain the FEC coding rate that is used for encoding of the payload of the MSG frame. It is a 3-bit unsigned integer field that shall be coded as shown in Table 7-12.

Table 7-12 – Interpretation of the FEC_RATE field

FEC_RATE value (b ₄ b ₃ b ₂)	Interpretation
000	Reserved by ITU-T
001	1/2
010	2/3
011	5/6
100	16/18
101	20/21
110 and 111	Reserved by ITU-T

7.1.2.3.2.2.4 Repetitions (REP)

The REP field shall contain the nominal number of repetitions that were used for encoding the payload in the MSG frame. It is a 3-bit field that shall be coded as shown in Table 7-8.

7.1.2.3.2.2.5 FEC concatenation factor (FCF)

The FCF field shall contain the values of parameters *H* and *z* (see clause 7.1.3.3.1). It is a 3-bit field that shall be coded as shown in Table 7-9.

7.1.2.3.2.2.6 Scrambler initialization (SI)

The SI field shall contain the value that was used to initialize the scrambler for this frame. It is a 4-bit field C₄C₃C₂C₁ as described in clause 7.1.3.1.

7.1.2.3.2.2.7 Master is detected indication (MDET)

The MDET bit shall indicate reception of a MAP. It is a 1-bit field that shall be set to one by a node, in each PHY-frame header that it transmits, when this node has received a MAP (either directly from the domain master or a repeated MAP) that the current MAC cycle is associated with. This indication

shall be used by nodes (including the backup domain master if it exists) to determine whether the current domain master has failed.

7.1.2.3.2.2.8 Bit allocation table identifier (BAT_ID)

The BAT_ID field shall identify the bit allocation table (BAT) of the PHY frame. It shall be represented as a 5-bit unsigned integer with valid values as shown in Table 7-57.

7.1.2.3.2.2.9 Bandplan identifier/subcarrier grouping identifier (BNDPL/GRP_ID)

For predefined BATs with uniform loading (type 0, type 1, type 2 and Type 3), the BNDPL/GRP_ID field shall contain the identifier for the bandplan used by the node and shall be coded as shown in Table 7-10. Otherwise, it shall contain the subcarrier grouping (see clause 7.1.4.2.4) and shall be coded as shown in Table 7-13.

Table 7-13 – Format of the GRP_ID

GRP_ID value (b ₇ b ₆ b ₅)	Description
000	Default – No subcarrier grouping
001	Subcarrier grouping of 2 subcarriers
010	Subcarrier grouping of 4 subcarriers
011	Subcarrier grouping of 8 subcarriers
100	Subcarrier grouping of 16 subcarriers
101 to 111	Reserved by ITU-T

7.1.2.3.2.2.10 Guard interval identifier (GI_ID)

The GI_ID field shall identify the guard interval used for payload (see clause 7.1.4.4). It is a 3-bit field that shall be coded as shown in Table 7-14.

Table 7-14 – Format of the GI_ID

GI_ID value (b ₂ b ₁ b ₀)	Description
000 to 110	N_{GI} guard interval (samples) $k \times N/32$, $k = 1, 2, 3, \dots, 7$ where $k = GI_ID + 1$, N is the size of the DFT
111	$k = 8$ (GI_ID=7) $N_{GI} = N_{GI-DF} = N/4$

7.1.2.3.2.2.11 Maximum Actual PSD ceiling of MSG frame (APSD_C_MAX-M)

The APSD_C_MAX-M and APSD_MAX-M_EXT fields shall together contain indicate the APSD_C_MAX value that is used infor the PHY frame. It shall be represented as a 56-bit unsigned integer with valid values in the range from 0 to 5025, plus 6234. Values from 0 to 5025 correspond to an actual APSD_MAX ceiling in the range of -50 dBm/Hz to -100 dBm/Hz in 21 dB steps.

The most significant 5 bits of the APSD_MAX are conveyed in the APSD_MAX-M field and the least significant bit of the APSD_MAX is conveyed in the APSD_MAX-M_EXT field.

The special value 6234 shall indicate that the frame has been transmitted with an APSD_MAX that is the minimum of:

- Highest value of the transmit PSD allowed (i.e., TxPSD after applying PSD ceiling if applicable)
- Highest value of the PSD that the node is capable of transmitting no PSD ceiling is applied.

All other ~~V~~ values from 26 to 30 are reserved by ITU-T.

7.1.2.3.2.2.12 Connection identifier (CONNECTION_ID)

The CONNECTION_ID field shall identify the connection that the LPDUs contained in the PHY-frame belong to. It shall be represented as an 8-bit unsigned integer. If a PHY-frame contains only management LPDUs (i.e., LPDUs from a unicast management connection or a broadcast management connection) and no data LPDUs, this field shall be set to 251 in that PHY-frame.

For connections associated with service flows, this field shall be set to the FLOW_ID. For prioritized data connections, it shall be set to the recommended flow priority given by Table III.1, denoted as PRI-Q, which depends on the user priority and the number of priority queues (traffic classes) supported from the source node to the destination node. The value shall be set to 255 for broadcast data connections and to 252 for multicast connections. In the case that the CNN_MNGMT field is set to 1111, CONNECTION_ID shall be set to 255.

The values 253 and 254 are reserved by ITU-T.

7.1.2.3.2.2.13 Reply required (RPRQ)

The RPRQ field shall be used to instruct the receiver whether or not to respond with an acknowledgement for this PHY frame. It is a 2-bit field that shall be coded as shown in Table 7-15.

Table 7-15 – RPRQ field allowed values

RPRQ value (b ₁ b ₀)	Interpretation
00	The receiver shall not acknowledge this PHY frame. The PHY frame does not require acknowledgement.
01	When MI is set to zero (unicast), the receiver shall acknowledge via an Imm-ACK frame. When MI is set to one (multicast), a slotted acknowledgement using multicast binding mechanism for slot assignment (see clause 8.9.2 of [ITU-T G.9961]) shall follow the transmission of this multicast MSG PHY frame. NACK signalling shall not be used. This mode shall only be used if each receiving node in the multicast group is assigned a Mc-ACK slot.
10	When MI is set to zero (unicast), the receiver shall defer the acknowledgement of the frame (see clause 8.9.1.2 of [ITU-T G.9961]). When MI is set to one (multicast), this value is reserved by ITU-T.
11	When MI is set to zero (unicast), this value is reserved by ITU-T. When MI is set to one (multicast), a slotted acknowledgement using multicast binding mechanism for slot assignment (see clause 8.9.2 of [ITU-T G.9961]) shall follow the transmission of this multicast MSG PHY frame. All receivers in the multicast group not assigned an acknowledgement slot that fail to receive the transmission by criteria described in clause 8.9.2.1 of [ITU-T G.9961] shall transmit a NACK in the NACK signalling slot.

7.1.2.3.2.2.14 Burst frame count (BRSTCnt)

The BRSTCnt field shall contain the sequence number of the PHY frame within a PHY frame burst, generated as described in clause 8.3.5 of [ITU-T G.9961]. It shall be represented as a 2-bit unsigned integer.

The BRSTCnt field shall be set to zero in the first PHY frame of the burst and shall be incremented by one upon each additional PHY frame of the same burst.

7.1.2.3.2.2.15 Burst end flag (BEF)

The BEF field shall indicate the end of a burst. It is a 1-bit field. The BEF shall be set to one in the last PHY frame of the burst and shall be set to zero in all other PHY frames. For bursts containing one frame (no bursting used) the BEF field shall be set to one.

7.1.2.3.2.2.16 AIFG indication (AIFG_IND)

For unicast, if the AIFG_IND field is set to one, the "receiver-specific" AIFG value, T_{AIFG} , shall be used by the transmitter. If the AIFG_IND field is set to zero, the "default" AIFG, T_{AIFG-D} shall be used. The receiver shall ACK this frame, whenever Imm-ACK is used, after either T_{AIFG} or T_{AIFG-D} , as indicated by AIFG_IND.

For multicast, the AIFG_IND field shall always be set to zero.

7.1.2.3.2.2.17 ACE symbols (ACE_SYM)

The ACE_SYM field shall contain the number of ACE symbols inserted between the header and payload of the MSG frame. It is a 3-bit field that shall be coded as shown in Table 7-16.

Table 7-16 – ACE_SYM field values

ACE_SYM value (b ₂ b ₁ b ₀)	Interpretation
000	0 ACE symbols
001	1 ACE symbols
010	2 ACE symbols
....
111	7 ACE symbols

7.1.2.3.2.2.18 Connection management (CNN_MNGMT)

The CNN_MNGMT field shall be used for the management of connections as defined in clause 8.12 of [ITU-T G.9961]. It is a 4-bit field that shall be coded as shown in Table 7-17.

Table 7-17 – CNN_MNGMT field values

CNN_MNGMT value (b ₇ b ₆ b ₅ b ₄)	Interpretation
0000	No action (may contain payload)
0001	Request to establish a management connection with acknowledgements (no payload allowed)
0010	Request to establish a management connection without acknowledgements (no payload allowed)
0011	Indication of reset of the management connection (no payload allowed)
0100	Indication of release of the management connection (no payload allowed)
0101	Request to establish a data connection with acknowledgements (no payload allowed)
0110	Request to establish a data connection without acknowledgements (no payload allowed)

Table 7-17 – CNN_MNGMT field values

CNN_MNGMT value (b₇b₆b₅b₄)	Interpretation
0111	Indication of reset of the data connection (no payload allowed)
1000	Indication of release of a data connection (no payload allowed)
1001 to 1110	Reserved for ITU-T
1111	Payload does not belong to any connection

When this field is equal to 0001 or 0011, the value of the ACK_TX_RESET variable (see clause 8.9.4.2 of [ITU-T G.9961]) of the state machine of the management connection is one. ACK_TX_RESET is zero when this field is 0000.

When this field is equal to 0101 or 0111, the value of the ACK_TX_RESET variable (see clause 8.9.4.2 of [ITU-T G.9961]) of the state machine of the data connection indicated by the CONNECTION_ID field of this MSG is one. ACK_TX_RESET is zero when this field is 0000.

7.1.2.3.2.2.19 Bandwidth reservation update request (BRURQ)

The BRURQ field shall contain updates in the bandwidth reserved for this node connection. It is a 16-bit field that shall be coded as shown in Table 7-18. The domain master shall follow the BRURQ fields of all nodes (see clause 8.6.2.2 of [ITU-T G.9961]).

Table 7-18 – Format of BRURQ field

Field	Octet	Bits	Description
ConnState	0	[7:0]	Contains the number of accumulated bytes in the connection queue. This value is specified in units of Kbytes, expressed as ceiling (number of bytes/1024).
FlowLineRate	1	[7:0]	Indicates the current PHY data rate in bytes/symbol. The range of valid values and the corresponding valid increments (see Table 7-19) depend on the medium. This value is expressed as floor (number of transmitted bytes per symbol/increment) (Note).
NOTE – Bytes/symbol value shall be calculated by applying the same formula and rules as Note 1 of Table 8-48 of [ITU-T G.9961] and multiplying the result by the symbol period (T _{OFDM} as defined in clause 7.1.4.4.4) and dividing by 8. DM shall consider this figure as an indication of the average throughput taking into account the different tone maps used in the MAC cycle.			

Table 7-19 – Valid increments for BRURQ field

Type	Increment
Power line	32 bytes
Telephone line	16 bytes
Coax	4 bytes

7.1.2.3.2.2.20 Start segment sequence number (START_SSN)

The START_SSN field shall contain the value of the ACK_TX_WINDOW_START variable of the transmitter at the establishment or reset of a connection. The receiver shall set its ACK_RX_WINDOW_START variable to this value.

The START_SSN field is defined only when CNN_MNGMT = 0001, CNN_MNGMT = 0011, CNN_MNGMT = 0101 or CNN_MNGMT = 0111 indicating the establishment or reset of a connection.

7.1.2.3.2.2.21 Current TS (CURRTS)

The CURRTS field shall contain the ordinal number of the TS in an STXOP that this MSG PHY frame is sent in as described in the MAP (see clause 8.8.5 of [ITU-T G.9961]). It shall be represented as a 7-bit unsigned integer.

A PHY frame that is sent in the first TS for a STXOP as described in the MAP shall have the number 1 in its CURRTS field; a PHY frame that is sent in the second TS of the STXOP shall have number 2 in its CURRTS field; and so on. The valid range of values for CURRTS field, for a specific STXOP, shall be from 1 to M , where M is the number of TSs in that STXOP, as described in the MAP (i.e., the number of TXOP descriptors).

A value of 0 shall be used for transmission not within an STXOP.

7.1.2.3.2.2.22 Request for bidirectional transmission (BTRQ)

The BTRQ bit shall be used to request the destination node to initiate bidirectional transmission with the source node of this MSG frame. It shall be set to one for a request and set to zero for no request (see clause 8.3.7 of [ITU-T G.9961]).

7.1.2.3.2.2.23 Number of Mc-ACK slots (NUM_MCACK_SLOTS)

The NUM_MCACK_SLOTS field shall contain the number of slotted Mc-ACKs when MI is set to one and the value of the RPRQ field is 01₂ or 11₂ (see Table 7-15). It shall be represented as a 3-bit unsigned integer.

The meaning of the NUM_MCACK_SLOTS field for other values of RPRQ when MI is set to one is reserved by ITU-T. When MI is set to zero, the NUM_MCACK_SLOTS field shall be set to zero and ignored by the receiver.

7.1.2.3.2.2.24 Advised Window Size (ADVISED_WIN_SIZE)

During the establishment of a data connection with acknowledgement, the transmitter may use the ADVISED_WIN_SIZE field to advise the receiver for the needed RX window size. The advised size of the RX window is given in number of LPDUs that is represented by the value in ADVISED_WIN_SIZE multiplied by 32 for the range of values from 01₁₆ to 1E₁₆. A special value of 1F₁₆ means that the window size is 1024 LPDUs. A special value of 00₁₆ means that the transmitter does not advise any value.

7.1.2.3.2.2.25 APSD MAX-M extension

[See clause 7.1.2.3.2.2.11.](#)

7.1.2.3.2.3 ACK PHY-frame type specific fields

Table 7-20 lists the PHY-frame header fields which are specific to the core part of the PHY-frame header of the ACK frame type.

Table 7-20 – ACK PHY frame type specific fields

Field	Octet	Bits	Description	Reference
FLCTRL_CONN	0	[0]	Flow control connection flag	Clause 7.1.2.3.2.3.1
FLCTRLT		[1]	Flow control type	Clause 7.1.2.3.2.3.2
FLCTRL		[6:2]	Flow control	Clause 7.1.2.3.2.3.3
FLCTRL_EXT		[7]	Flow control extension	Clause 7.1.2.3.2.3.11

Table 7-20 – ACK PHY frame type specific fields

Field	Octet	Bits	Description	Reference
RXRST_DATA	1	[0]	Data RX reset flag	Clause 7.1.2.3.2.3.5
RXRST_MNGMT		[1]	Management RX reset flag	Clause 7.1.2.3.2.3.6
BAD_BURST		[2]	Bad burst indication	Clause 7.1.2.3.2.3.7
BTXRQ		[3]	Request for bidirectional transmission	Clause 7.1.2.3.2.3.4
EXTACKRQ		[4]	Request for extended acknowledgement	Clause 7.1.2.3.2.3.10
Reserved		[7:5]	Reserved	Reserved by ITU-T (Note 2)
ACK_CE_CTRL/ RX_CONN_WIN_SIZE	2	[6:0]	ACK channel estimation control/Receiver window size for the connection. (Note 1)	Clause 7.1.2.3.2.3.8
Reserved		[7]	Reserved	Reserved for use by ITU-T G.9963 (Note 2)
ACKDATA/MACK_D	3 to 14	[90:0]	Acknowledgement data and Mc-ACK descriptor	Clause 7.1.2.3.2.3.9
Reserved		[95:91]	Reserved	Reserved by ITU-T (Note 2)
<p>NOTE 1 – This field is interpreted as RX_CONN_WIN_SIZE only when the ACK frame is sent as a reply for MSG frame requesting set-up or reset of either a data or a management connection (i.e., when CNN_MNGMT in the MSG frame is 0101₂, 0001₂, 0011₂ or 0111₂).</p> <p>NOTE 2 – Bits that are reserved by ITU-T shall be set to zero by the transmitter and ignored by the receiver.</p>				

7.1.2.3.2.3.1 Flow control connection flag (FLCTRL_CONN)

The FLCTRL_CONN field defines the interpretation of the FLCTRL and FLCTRLT fields. When the FLCTRL_CONN field is set to zero, fields FLCTRL and FLCTRLT shall carry information about a data connection. When the FLCTRL_CONN field is set to one, fields FLCTRL and FLCTRLT shall carry information about the management connection.

7.1.2.3.2.3.2 Flow control type (FLCTRLT)

The FLCTRLT field shall contain the interpretation of the FLCTRL field according to Table 7-21.

Table 7-21 – FLCTRLT field values

FLCTRLT value (b ₁)	Interpretation
0	Status report
1	Hold time/management

7.1.2.3.2.3.3 Flow control (FLCTRL)

The FLCTRL field shall be used for flow control between the transmitter and the receiver as described in clause 8.12.4 of [ITU-T G.9961]. Interpretation of the FLCTRL field depends on the setting of the FLCTRLT field.

If the FLCTRLT field is set to zero (status report), the FLCTRL field shall contain the number of LPDUs that the receiver can buffer for this flow. It is a 5-bit field that shall be coded as shown in Table 7-22.

Table 7-22 – FLCTRL field values for status report

FLCTRL value (b₆b₅b₄b₃b₂)	Connections with 540 byte LPDUs	Connections with 120 byte LPDUs
00000	4	6
00001	8	12
00010	12	18
00011	16	24
00100	20	30
00101	24	36
00110	28	42
00111	32	48
01000	40	60
01001	48	72
01010	56	84
01011	64	96
01100	72	108
01101	80	120
01110	88	132
01111	104	156
10000	120	180
10001	136	204
10010	152	228
10011	168	252
10100	184	276
10101	200	300
10110	216	324
10111	232	348
11000	248	372
11001	264	396
11010	280	420
11011	296	444
11100	312	468
11101	328	492
11110	344	516
11111	376	564

If the FLCTRLT field is set to one (hold time/management), the FLCTRL field shall contain either the time period that the transmitter shall hold transmissions to this node, or connection management information (see clause 8.12 of [ITU-T G.9961]). It is a 5-bit field that shall be coded as shown in Table 7-23.

Table 7-23 – FLCTRL field values for hold time/management

FLCTRL value (b₆b₅b₄b₃b₂)	Interpretation
Hold times	
00000	Until next MAC cycle
00001	5 ms
00010	10 ms
00011	15 ms
00100	20 ms
00101	30 ms
00110	40 ms
00111	50 ms
01000 to 11011	Reserved by ITU-T
Management	
11100	Release acknowledgement
11101	Connection release indication
11110	Connection accepted
11111	Unavailability of resources

The receiver shall set the FLCTRLT field to one to convey the following connection management information (see clause 8.12 of [ITU-T G.9961]):

- If the transmitter has requested the release of a connection, the receiver shall acknowledge the release by setting the FLCTRL field to 11100₂.
- If the receiver wants to release a connection, it shall inform the transmitter by setting the FLCTRL field to 11101₂.
- If the receiver accepts a requested connection, it shall inform the transmitter by setting the FLCTRL field to 11110₂.
- If the receiver does not have resources available for a requested connection, it shall inform the transmitter by setting the FLCTRL field to 11111₂.

7.1.2.3.2.3.4 Request for bidirectional transmission (BTXRQ)

The BTXRQ bit shall be used to request bidirectional transmission. It shall be set to one for a request and set to zero for no request (see clause 8.3.7 of [ITU-T G.9961]).

7.1.2.3.2.3.5 Data RX reset flag (RXRST_DATA)

The RXRST_DATA field shall contain the value of the ACK_RX_RESET variable of the state machine of the data connection that this ACK refers to (see clause 8.9.5.3 of [ITU-T G.9961]).

7.1.2.3.2.3.6 Management RX reset flag (RXRST_MNGMT)

The RXRST_MNGMT field shall contain the value of the ACK_RX_RESET variable of the state machine of the management flow that this ACK refers to (see clause 8.9.5.3 of [ITU-T G.9961]).

7.1.2.3.2.3.7 Bad burst indication (BAD_BURST)

The BAD_BURST field shall be used by the receiver to indicate to the transmitter that all LPDUs sent in the last PHY-frame burst were received in error.

When all LPDUs of all frames (one or more) of the last PHY-frame burst have been received in error, the BAD_BURST field shall be set to one; otherwise, it shall be set to zero.

7.1.2.3.2.3.8 ACK channel estimation control/Receiver window size for the connection (ACK_CE_CTRL/RX_CONN_WIN_SIZE)

In the case of an ACK frame sent in response to an MSG frame requesting the set-up or reset of a data or management connection with acknowledgements (i.e., when CNN_MNGMT in the MSG frame is 0101₂, 0001₂, 0011₂ or 0111₂, see Table 7-17), this parameter is called RX_CONN_WIN_SIZE and the value of this parameter shall indicate the maximum acknowledge window size (i.e., ACK_RX_CONF_WINDOW_SIZE in clause 8.9.4.3 of [ITU-T G.9961]) that the receiver can support for the connection being set up. The maximum acknowledge window size shall be 8 times the value of (RX_CONN_WIN_SIZE+1) LPDUs. The valid values for the maximum acknowledge window size shall be 8, 16, 24 ... 1024 LPDUs. The indicated value of maximum acknowledge window size shall be less than or equal to ACK_MAX_WINDOW_SIZE (1024 for data connections, 32 for management connections – see clause 8.9.4.1 of [ITU-T G.9961]).

For all other ACK frames, this field is called ACK_CE_CTRL and is used for channel estimation control. It is a 7-bit field that consists of the ACK_CE_CTRL_TYPE field and the RUNTIME_BAT_ID field as shown in Table 7-24.

Table 7-24 – Interpretation of the ACK_CE_CTRL field

Field	Octet	Bits
ACK_CE_CTRL_TYPE	0	[1:0]
RUNTIME_BAT_ID		[6:2]
Reserved for [ITU-T G.9963]		[7]

7.1.2.3.2.3.8.1 ACK channel estimation control type (ACK_CE_CTRL_TYPE)

ACK_CE_CTRL_TYPE is a 2-bit field that shall be coded as shown in Table 7-25.

Table 7-25 – ACK_CE_CTRL_TYPE field values

ACK_CE_CTRL_TYPE value (b ₁ b ₀)	Interpretation
00	No ACK_CE_CTRL information is transmitted
01	RUNTIME_BAT_ID is invalid
10	Request PROBE frame transmission.
11	Reserved by ITU-T

If the ACK_CE_CTRL_TYPE field is set to 01₂, the runtime BAT associated with the RUNTIME_BAT_ID shall not be used for transmission, as specified in clause 8.11.5 of [ITU-T G.9961].

In addition, if the ACK_CE_CTRL_TYPE field is set to 10₂, a PROBE frame transmission is requested.

Otherwise, the ACK_CE_CTRL_TYPE field shall be set to 00₂.

7.1.2.3.2.3.8.2 Runtime BAT ID (RUNTIME_BAT_ID)

If the ACK_CE_CTRL_TYPE field is set to 01₂, this field shall contain a RUNTIME_BAT_ID (see Table 7-57). Otherwise, it shall be set to 00000₂.

7.1.2.3.2.3.9 Acknowledgement data and Mc-ACK descriptor (ACKDATA/MCACK_D)

If the MI field is set to zero (for unicast acknowledgement), this field shall contain a 91-bit ACKDATA field.

If the MI field is set to one (for multicast acknowledgement), this field shall contain a 12-bit Mc-ACK descriptor (see clause 7.1.2.3.2.3.9.2) followed by a 79-bit ACKDATA field.

7.1.2.3.2.3.9.1 ACKDATA

The ACKDATA field for different cases shall be coded as shown in Tables 7-26, 7-27, 7-28 and 7-29.

Table 7-26 – Unicast ACKDATA specific fields when MNMTP is set to zero

Field	Octet	Bits
FAACK	0 to 11	[2:0]
CONNECTION_ID		[10:3]
MNMTP		[11]
LSSN		[23:12]
ACKI		[90:24]
Reserved (See Table 7-20)		[95:91]

Table 7-27 – Unicast ACKDATA specific fields when MNMTP is set to one

Field	Octet	Bits
FAACK	0 to 11	[2:0]
CONNECTION_ID		[10:3]
MNMTP		[11]
MNMT_LSSN		[17:12]
MNMTL		[22:18]
MNMT_ACKI		[(MNMTL_VALUE+22):23]
LSSN		[(MNMTL_VALUE+34):(MNMTL_VALUE+23)]
ACKI		[90:(MNMTL_VALUE+35)]
Reserved (see Table 7-20)		[95:91]

Table 7-28 – Multicast ACKDATA specific fields when MNMTP is set to zero

Field	Octet	Bits
Mc-ACK descriptor (see Table 7-35)	0 to 11	[11:0]
FAACK		[14:12]
CONNECTION_ID		[22:15]
MNMTP		[23]
LSSN		[35:24]
ACKI		[90:36]
Reserved (see Table 7-20)		[95:91]

Table 7-29 – Multicast ACKDATA specific fields when MNMTP is set to one

Field	Octet	Bits
Mc-ACK descriptor (see Table 7-35)	0 to 11	[11:0]
FACK		[14:12]
CONNECTION_ID		[22:15]
MNMTP		[23]
MNMT_LSSN		[29:24]
MNMTL		[34:30]
MNMT_ACKI		[(MNMTL_VALUE+34):35]
LSSN		[(MNMTL_VALUE+46):(MNMTL_VALUE+35)]
ACKI		[90:(MNMTL_VALUE+47)]
Reserved (see Table 7-20)		[95:91]

The format of the FACK field shall be as described in clause 7.1.2.3.2.3.9.1.5. When selective acknowledgment is used, the FACK field shall indicate the format of the ACKI field.

7.1.2.3.2.3.9.1.1 Management LSSN presence indication (MNMTP)

When MNMTP is set to zero, the format of the ACKDATA field shall be as described in Table 7-26 for unicast and Table 7-28 for multicast. When MNMTP is set to one, the format of the ACKDATA field shall be as described in Table 7-27 for unicast and Table 7-29 for multicast.

7.1.2.3.2.3.9.1.2 ACKDATA when MNMTP is set to zero

The format of the LSSN field shall be as described in clause 7.1.2.3.2.3.9.1.6.

The format of the ACKI field shall be as described in clause 7.1.2.3.2.3.9.1.7.

7.1.2.3.2.3.9.1.3 ACKDATA when MNMTP is set to one

If MNMTP (see clause 7.1.2.3.2.3.9.1.1) is set to one, the LSSN field (see clause 7.1.2.3.2.3.9.1.6) and the ACKI (see clause 7.1.2.3.2.3.9.1.7) field shall refer to the receiver window corresponding to the data connection (see clauses 8.1.3.2.1.4 and 8.12 of [\[ITU-T G.9961\]](#)).

7.1.2.3.2.3.9.1.3.1 Management lowest SSN (MNMT_LSSN)

The MNMT_LSSN field shall hold the six LSBs of the ACK_RX_WINDOW_START of the receiver window corresponding to the management connection (see clauses 8.1.3.2.1.4 and 8.12 of [\[ITU-T G.9961\]](#)).

7.1.2.3.2.3.9.1.3.2 Management ACKI length (MNMTL)

The MNMTL field shall contain the variable MNMTL_VALUE representing the size in bits of the MNMT_ACKI field. It shall be represented as a 5-bit unsigned integer with valid values in the range from 00000₂ to 11111₂.

7.1.2.3.2.3.9.1.3.3 Management bit map encoding (MNMT_ACKI)

If MNMTL > 0, the MNMT_ACKI field shall contain a bit array indicating the correct reception of segments in the receiver window corresponding to the management connection (see clauses 8.1.3.2.1.4 and 8.12 of [\[ITU-T G.9961\]](#)). The bit corresponding to a segment shall be set to zero if the segment was received correctly. Otherwise, it shall be set to one. The first MNMT_ACKI bit shall represent the reception status of the segment with SSN equal to ACK_RX_WINDOW_START+1, the second MNMT_ACKI bit shall represent the reception status of the segment with SSN equal to ACK_RX_WINDOW_START+2, and so on until the last correctly received segment within the ACK_RX_CONF_WINDOW.

Segments for which the reception status was not reported in the MNMT_ACKI shall be considered by the transmitter as not received correctly by the receiver.

7.1.2.3.2.3.9.1.4 Connection identifier (CONNECTION_ID)

The CONNECTION_ID field shall identify the connection (see clause 7.1.2.3.2.2.12) corresponding to the LPDUs being acknowledged. It shall be represented as an 8-bit unsigned integer. The value 255 shall be used to indicate that no acknowledgement information is included in the ACKDATA field. If the ACKDATA field contains acknowledgement information about only the management connection, the CONNECTION_ID shall be set to 251. If the ACKDATA field contains acknowledgement information about a multicast connection, the CONNECTION_ID shall be set to 252.

The values 253 and 254 are reserved by ITU-T.

7.1.2.3.2.3.9.1.5 Frame ACK (FACK)

The FACK field shall be used to indicate the format of the ACKI field message included in the ACK message. It is a 3-bit field that shall be coded as shown in Table 7-30.

Table 7-30 – FACK field values

FACK value (b ₂ b ₁ b ₀)	Interpretation
000	Selective acknowledgement – ACKI format is bit map
001	Selective acknowledgement – ACKI format is run-length encoded
010	Selective acknowledgement – ACKI format is group encoded
011 to 110	Reserved by ITU-T
111	All the fields of the FTSF of ACK PHY-frame, other than FACK, are not valid. This value shall only be used for ACK PHY-frame.

7.1.2.3.2.3.9.1.6 Lowest SSN (LSSN)

The LSSN field shall contain the 12 LSBs of the ACK_RX_WINDOW_START of the receive window.

7.1.2.3.2.3.9.1.7 ACK information (ACKI)

The reception status of data units consisting of one or more segments shall be indicated in the ACKI field by the receiver. The data unit corresponding to each indication in the ACKI field depends on the format of the ACKI field (see Table 7-30). The indication corresponding to a data unit shall be set to one if the data unit was not received correctly and shall be set to zero if the data unit was received correctly. For the cases of bit map encoding and group encoding, if there is no more information to encode, the remaining bits of this field (if any) shall be encoded by the receiver to indicate that the rest of the data units have been received with errors. For the case of run-length encoding, if there is no more information to encode, the remaining bits of this field (if any) shall be encoded to indicate that the rest of the groups in the field have a length of zero. The specific encoding for different formats of the ACKI field is as explained in the following clauses.

If the number of bits in the ACKI field is not sufficient to indicate reception status of all the received segments, a receiver may choose to use compressed encoding or limit the indication to the number of available bits. Segments corresponding to data units for which the reception status was not reported shall be considered by the transmitter as either not received correctly by the receiver or in waiting-for-ack state.

If the number of bits in the ACKI field is not sufficient, the receiver may indicate to the transmitter that it would like to use the extended ACK in future frames by setting the EXTACKRQ bit as described in clause 7.1.2.3.2.3.10.

If the transmitter has already granted permission to the receiver to use extended ACK, the receiver may use extended ACK as described in clause 8.3.8 of [ITU-T G.9961]. The format of the ACK extension is as described in clause 7.1.2.3.3.1.4.

7.1.2.3.2.3.9.1.7.1 Bit map encoding

When the FACK field indicates bit map encoding, the ACKI field shall be encoded as a bit array.

The ACKI field shall contain an indication of the correct reception of segments in the receiver window. The first ACKI bit shall represent the reception status of the segment with SSN equal to ACK_RX_WINDOW_START+1, the second ACKI bit shall represent the reception status of the segment with SSN equal to ACK_RX_WINDOW_START+2, and so on until the last correctly received segment within the ACK_RX_CONF_WINDOW.

If there is no more information to encode, the remaining bits, if any, of the ACKI field shall be set to one by the receiver.

7.1.2.3.2.3.9.1.7.2 Compressed encoding

In the compressed coding format, the reception status of the received segments shall be transmitted by groups. None of the segments received with errors shall be coded as correctly received. Correctly received segments may be encoded as incorrectly received.

The grouping of segments shall start from the segment with SSN equal to ACK_RX_WINDOW_START+1.

If there is no more information to encode, the remaining bits of the ACKI field, if any, shall be encoded by the receiver indicating that the rest of the segments have been received with errors.

7.1.2.3.2.3.9.1.7.2.1 Run-length encoding

With run-length encoding, the number of segments belonging to a group defines the length of the group. The GRPLGTH field shall indicate the length of each group, which is variable. It shall be represented as a 3-bit unsigned integer as shown in Table 7-31 and shall be coded as shown in Table 7-32.

Table 7-31 – ACKI subfields with run-length encoding

Field	Size in bits
GRPLGTH	3
GRP ₀	GRPLGTH
...	
GRP _N	GRPLGTH

Table 7-32 – Encoding of GRPLGTH values

Value of the GRPLGTH field	GRPLGTH interpretation
0	GRPLGTH=2
1	GRPLGTH=3
...	...
7	GRPLGTH=9

The first group (GRP₀) indicates the number of consecutive segments that have not been correctly received.

If one group (GRP_i) indicates the number of segments that have been received correctly, the next group (GRP_{i+1}) shall indicate the number of segments that have been received incorrectly or not received.

If one group (GRP_i) indicates the number of segments that have been received incorrectly or not received, the next group (GRP_{i+1}) shall indicate the number of segments that have been received correctly.

If the length of ACKI field, excluding GRPLGTH field, ($N_{\text{BitsForGroups}}$) is not multiple of the number of bits used to specify the length of the group (GRPLGTH interpretation, as defined in Table 7-31), the last $P = \text{remainder}(N_{\text{BitsForGroups}}/\text{GRPLGTH interpretation})$ bits of the ACKI field, shall be considered as padding and shall be ignored by the transmitter.

7.1.2.3.2.3.9.1.7.2.2 Group encoding

With group encoding, all groups shall have the same number of segments. The COMP_RT field shall contain the number of segments that form a group. It shall be represented as a 3-bit unsigned integer as shown in Table 7-33 and shall be coded as shown in Table 7-34.

The GRP_MAP field shall be used to represent the status of all groups. Each bit of the field shall indicate the status of one group, where a one shall indicate that at least one segment in the group was not received correctly and a zero shall indicate that all segments in the group were received correctly.

Table 7-33 – ACKI subfields with group encoding

Field	Size in bits
COMP_RT	3
GRP_MAP	Rest of the ACKI bits

Table 7-34 – Encoding of COMP_RT values

Value of the COMP_RT field	COMP_RT interpretation
0	COMP_RT=2
1	COMP_RT=3
...	...
7	COMP_RT=9

7.1.2.3.2.3.9.2 Mc-ACK descriptor (MACK_D)

The MACK_D field is only valid for multicast acknowledgement (Mc-ACK). It is a 12-bit field that shall be coded as shown in Table 7-35.

Table 7-35 – MACK_D fields description

Field	Octet	Bits	Description
MC_SID	0	[7:0]	DEVICE_ID of the multicast frame source that requested Mc-ACK
NUM_SLT	1	[2:0]	Number of Mc-ACK slots assigned after this Mc-ACK slot, represented as unsigned integer in the range between 0 and 6. The value 7 is reserved by ITU-T.
NACKP		[3]	Indicates presence of NACK (see Table 7-15): 0 – NACK signalling slot is not present 1 – NACK signalling slot is present

7.1.2.3.2.3.10 Extended ACK requested (EXTACKRQ)

If the EXTACKRQ field is set to one, it shall indicate that the node transmitting the ACK frame would like to send extended ACKs and the source node should allocate time for an extended ACK in future frames as described in clause 8.3.8 of [ITU-T G.9961]. If the EXTACKRQ field is set to zero, it shall indicate that the node transmitting the ACK frame will not be using extended ACKs and does not require the extra resources.

7.1.2.3.2.3.11 Flow control extension (FLCTRL_EXT)

The FLCTRL_EXT field shall be used to indicate higher values of flow control between the transmitter and the receiver as described in clause 8.12.4 of [ITU-T G.9961], compared to those indicated by the field FLCTRL as described in clause 7.1.2.3.2.3.3. This field FLCTRL_EXT shall be set to one only if the field FLCTRLT is set to 0 (see clause 7.1.2.3.2.3.2). If FLCTRL_EXT is set to one, for connections with 540 byte LPDUs 408 is added and for connections with 120 byte LPDUs 612 is added to the value indicated by the FLCTRL (see clause 7.1.2.3.2.3.3) value to determine the actual number of LPDUs that the receiver can buffer for the flow. For example, for a connection with 540 byte LPDUs, if FLCTRL_EXT is set and FLCTRL is set to 0001₂ the receiver indicates that it can buffer (408 + 16 = 424) LPDUs.

7.1.2.3.2.4 RTS PHY-frame type specific fields

Table 7-36 lists the PHY-frame header fields which are specific to the RTS frame type:

Table 7-36 – RTS PHY-frame type specific fields

Field	Octet	Bits	Description	Reference
RTS_DUR	0 and 1	[15:0]	Duration for RTS frame	Clause 7.1.2.3.2.4.1
CID	2	[7:0]	CTS proxy ID	Clause 7.1.2.3.2.4.2
CURRTS	3	[6:0]	Current TS	Clause 7.1.2.3.2.4.3
Reserved		[7]	Reserved	Reserved by ITU-T (Note)
Reserved	4 to 14	[87:0]	Reserved	Reserved by ITU-T (Note)

NOTE – Bits that are reserved by ITU-T shall be set to zero by the transmitter and ignored by the receiver.

7.1.2.3.2.4.1 Duration for RTS frame (RTS_DUR)

The RTS_DUR field shall contain the total duration of the following sequence:

- the transmission time of the RTS frame;

- duration of RCIFG between RTS and CTS frames;
- the transmission time of the CTS frame;
- the transmission time of the MSG frames that follow the CTS frame and the BIFGs that separate them;
- duration of CCIFG between CTS frame and MSG frame that follows CTS frame;
- if ACK is required, the duration of the AIFG and the ACK frames;
- if Mc-ACK is required, the duration of default AIFG gap and the Mc-ACK sequence duration.

7.1.2.3.2.4.2 CTS proxy ID (CID)

The CID field shall contain the DEVICE_ID of the node that should respond in CTS for multicast traffic. It shall be represented as an 8-bit unsigned integer with valid values in the range from 1 to 250.

7.1.2.3.2.4.3 Current TS (CURRTS)

The interpretation of this field shall be as specified in clause 7.1.2.3.2.2.21, the CURRTS field of the MSG frame.

7.1.2.3.2.5 CTS PHY-frame type specific fields

Table 7-37 lists the header fields which are specific to the CTS frame type.

Table 7-37 – Specific fields of the CTS PHY-frame type

Field	Octet	Bits	Description	Reference
CTS_DUR	0 and 1	[15:0]	Duration for CTS frame	Clause 7.1.2.3.2.5.1
Reserved	2 to 14	[103:0]	Reserved	Reserved by ITU-T (Note)
NOTE – Bits that are reserved by ITU-T shall be set to zero by the transmitter and ignored by the receiver.				

7.1.2.3.2.5.1 Duration for CTS frame (CTS_DUR)

The CTS_DUR field shall repeat the duration expressed in the preceding RTS frame minus the RTS frame transmission time and the inter-frame gap that follows the RTS frame.

7.1.2.3.2.6 CTMG PHY-frame type specific fields

Table 7-38 lists the PHY-frame header fields which are specific to the CTMG frame type.

Table 7-38 – CTMG PHY-frame type specific fields

Field	Octet	Bits	Description	Reference
IACKRQ	0	[0]	Immediate acknowledgment required	Clause 7.1.2.3.2.6.1
CURRTS		[7:1]	Current TS	Clause 7.1.2.3.2.6.3
CTMGD	1 to 14	[111:0]	CTMG data	Clause 7.1.2.3.2.6.2

7.1.2.3.2.6.1 Immediate acknowledgment required (IACKRQ)

When the IACKRQ field is set to one, the receiver shall follow the reception of the CTMG frame with an acknowledgement CTMG frame (ACTMG) T_{AIFG-D} (see clause 8.4 of [ITU-T G.9961], and clause 7.1.2.3.2.6.2) after the end of the CTMG frame. All nodes in the domain shall refrain from transmission when an ACTMG frame is expected and within T_{IFG_MIN} following it. The sender shall plan its transmission so that the ACTMG that follows the transmitted CTMG frame is contained within the TXOP or TS assigned for the transmission.

7.1.2.3.2.6.2 CTMG data (CTMGD)

If the EHI field is set to zero, the CTMGD field shall contain a single control message composed of a CMH and a CMPL field as shown in clause 8.10.2 of [ITU-T G.9961]. If the size of the control message is shorter than the size of CTMGD (112 bits), the remainder of the CTMGD field shall be padded with zeros.

If the EHI field is set to one, concatenated CTMGD and CTMGD_EXT fields (see clause 7.1.2.3.3.1.1.1) shall be considered as one field, the first byte (octet 0) of the CTMGD field being the first byte of the combined field and the last byte of the CTMGD_EXT field being the last byte of the combined field. The combined field shall contain a single control message. In this case the size of the control message shall be less than or equal to the size of the combined field. The remainder of the CTMGD_EXT field shall be padded with zeros.

7.1.2.3.2.6.3 Current TS (CURRTS)

The interpretation of this field shall be as specified in clause 7.1.2.3.2.2.21, the CURRTS field of the MSG frame.

7.1.2.3.2.7 PROBE PHY-frame type specific fields

The PROBE PHY-frame type specific field is composed of a common part and a variable part. The common part contains fields that are common for all PROBE PHY-frame types (PRBTYPES). The variable part contains fields that are specific to each PRBTYPES.

The fields of the common part of the PROBE PHY-frame specific field are defined in Table 7-39.

Table 7-39 – PROBE PHY-frame type specific fields

Field	Octet	Bits	Description	Reference
Common part				
PRB_DUR	0 and 1	[15:0]	Duration for PROBE frame	Clause 7.1.2.3.2.7.1.1
PRBTYPES	2	[3:0]	PROBE frame type	Clause 7.1.2.3.2.7.1.2
PRBSYM		[7:4]	Probe symbols	Clause 7.1.2.3.2.7.1.3
APSD<u>_MAX-P	3	[4:0]	<u>Actual PSD ceiling</u> APSD_MAX-P of a PROBE frame	Clause 7.1.2.3.2.7.1.4
PRBGI		[7:5]	PROBE guard interval	Clause 7.1.2.3.2.7.1.5
CURRTS	4	[6:0]	Current TS	Clause 7.1.2.3.2.7.1.6
Reserved		[7]	Reserved	Reserved for use by ITU-T G.9963 (NOTE)
<u>APSD_MAX-P_EXT</u>	5	[0]	<u>APSD_MAX-P extension</u>	<u>Clause 7.1.2.3.2.7.1.7</u>
Reserved		[7: <u>10</u>]	Reserved	Reserved by ITU-T (Note)
Variable part				
PFTSF	6 to 14	[71:0]	PROBE frame type specific field	Clause 7.1.2.3.2.7.2
NOTE – Bits that are reserved by ITU-T shall be set to zero by the transmitter and ignored by the receiver.				

7.1.2.3.2.7.1 Common part fields

7.1.2.3.2.7.1.1 Duration for PROBE frame (PRB_DUR)

The PRB_DUR field shall contain the transmission time of the PROBE frame.

7.1.2.3.2.7.1.2 PROBE frame type (PRBTYPE)

The PRBTYPE field shall contain the type of the PROBE frame. It is a 4-bit field that shall be coded as shown in Table 7-40.

Table 7-40 – PRBTYPE field values

PRBTYPE value (b ₃ b ₂ b ₁ b ₀)	Interpretation	Reference
0000	Silent PROBE frame – a PHY frame in which the probe symbols composing the payload shall all be silent symbols, as specified in clause 7.1.3.6.	Clause 7.1.2.3.2.7.2.1
0001	Channel estimation PROBE frame – a PHY frame in which the probe symbols composing the payload shall all be channel estimation probe symbols, as specified in clause 7.1.3.6.	Clause 7.1.2.3.2.7.2.2
0010 to 1111	Reserved by ITU-T	

7.1.2.3.2.7.1.3 Probe symbols (PRBSYM)

The PRBSYM field shall contain the number of OFDM payload symbols in the PROBE frame. It is a 4-bit field that shall be coded as shown in Table 7-41.

Table 7-41 – PRBSYM field values

PRBSYM value (b ₇ b ₆ b ₅ b ₄)	Interpretation
0000	4 Payload symbols
0001	8 Payload symbols
0010	12 Payload symbols
....
1111	64 Payload symbols

7.1.2.3.2.7.1.4 Maximum actual PSD of PROBE frame (APSD_MAX-P)

The APSD_MAX-P and APSD_MAX-P_EXT fields shall together indicate the APSD_MAX for the PHY frame. It shall be represented as a 56-bit unsigned integer with valid values in the range from 0 to 2550, plus 3162. Values from 0 to 2550 correspond to an APSD_MAX in the range of –50 dBm/Hz to –100 dBm/Hz in 2-1 dB steps.

The most significant 5 bits of the APSD_MAX are conveyed in the APSD_MAX-P field and the least significant bit of the APSD_MAX is conveyed in the APS_MAX-P_EXT field.

The special value 3162 shall indicate that the frame has been transmitted with an APSD_MAX that is the minimum of:

- Highest value of the transmit PSD allowed (i.e., TxPSD after applying PSD ceiling if applicable)
- Highest value of the PSD that the node is capable of transmitting.

All other values Values from 26 to 30 are reserved by ITU-T.

7.1.2.3.2.7.1.5 PROBE symbol guard interval (PRBGI)

The PRBGI field shall contain the guard interval value used for the payload of the PROBE frame. It shall be coded in the same way as described in Table 7-14 in clause 7.1.2.3.2.2.10.

7.1.2.3.2.7.1.6 Current TS (CURRTS)

The interpretation of this field shall be as specified in clause 7.1.2.3.2.2.21, the CURRTS field of the MSG frame.

7.1.2.3.2.7.1.7 APSD MAX-P extension

See clause 7.1.2.3.2.7.1.4.

7.1.2.3.2.7.2 PROBE frame type specific field

This clause details the PROBE frame-type specific field (PFTSF), a variable part of the PROBE PHY-frame type specific field separately defined for each PROBE frame type (PRBTYPE).

7.1.2.3.2.7.2.1 Silent PROBE frame specific fields

Table 7-42 lists the PROBE frame fields which are specific to the silent PROBE frame type.

Table 7-42 – Silent PROBE frame specific field values

Field	Octet	Bits	Description
Reserved	0 to 8	[71:0]	Reserved by ITU-T (Note)
NOTE – Bits that are reserved by ITU-T shall be set to zero by the transmitter and ignored by the receiver.			

7.1.2.3.2.7.2.2 Channel estimation PROBE frame specific fields

Table 7-43 lists the PROBE frame fields which are specific to the channel estimation PROBE frame type.

Table 7-43 – Channel estimation PROBE frame specific field values

Field	Octet	Bits	Description
Reserved	0 to 8	[71:0]	Reserved by ITU-T (Note)
NOTE – Bits that are reserved by ITU-T shall be set to zero by the transmitter and ignored by the receiver.			

Table 7-44 – Placeholder table

(This table has been intentionally left blank.)

7.1.2.3.2.8 ACKRQ PHY frame type specific fields

Table 7-45 lists the PHY-frame header fields which are specific to the ACKRQ frame type.

Table 7-45 – ACKRQ PHY-frame type specific fields

Field	Octet	Bits	Description	Reference
RX_WIN_TYPE	0	[1:0]	Requested RX window	Clause 7.1.2.3.2.8.1
Reserved		[7:2]	Reserved	Reserved by ITU-T (Note)
CONNECTION_ID	1	[7:0]	Connection identifier	Clause 7.1.2.3.2.8.2
CURRTS	2	[6:0]	Current TS	Clause 7.1.2.3.2.8.3
Reserved		[7]	Reserved	Reserved by ITU-T (Note)
Reserved	3 to 14	[95:0]	Reserved	Reserved by ITU-T (Note)
NOTE – Bits that are reserved by ITU-T shall be set to zero by the transmitter and ignored by the receiver.				

7.1.2.3.2.8.1 Requested RX window (RX_WIN_TYPE)

The RX_WIN_TYPE field shall indicate which receiver window status is requested to be retransmitted according to Table 7-46.

Table 7-46 – RX_WIN_TYPE field allowed values

RX_WIN_TYPE value (b₁b₀)	Description
00	The receiver shall only send the current status of the reception window of the data connection identified by the CONNECTION_ID field and the SID of the ACKRQ frame.
01	The receiver shall only send the current status of the reception window of the management connection from the SID of the ACKRQ frame.
10	The receiver shall send the current status of the reception windows of: <ul style="list-style-type: none">• the management connection from the SID of the ACKRQ frame;• the data connection identified by the CONNECTION_ID and the SID of the ACKRQ frame.
11	Reserved by ITU-T

7.1.2.3.2.8.2 Connection identifier (CONNECTION_ID)

The interpretation of this field shall be as specified in clause 7.1.2.3.2.2.12, the CONNECTION_ID field of the MSG frame.

7.1.2.3.2.8.3 Current TS (CURRTS)

The interpretation of this field shall be as specified in clause 7.1.2.3.2.2.21, the CURRTS field of the MSG frame.

7.1.2.3.2.9 BMSG PHY-frame type specific fields

Table 7-47 lists the fields which are specific to the core part of the PHY-frame header of the BMSG frame type.

Table 7-47 – BMSG PHY-frame type specific fields – core part

Field	Octet	Bits	Description	Reference
BMSG_DUR	0 and 1	[15:0]	Duration for BMSG frame	Clause 7.1.2.3.2.9.1
BLKSZ	2	[1:0]	Block size of FEC codeword for BMSG frame payload	Clause 7.1.2.3.2.9.2
FEC_RATE		[4:2]	FEC coding rate for BMSG frame payload	Clause 7.1.2.3.2.9.3
REP		[7:5]	Number of repetitions used for encoding the BMSG frame payload	Clause 7.1.2.3.2.9.4
FCF	3	[2:0]	FEC concatenation factor	Clause 7.1.2.3.2.9.5
SI		[6:3]	Scrambler initialization	Clause 7.1.2.3.2.9.6
MDET		[7]	Master is detected	Clause 7.1.2.3.2.9.7

Table 7-47 – BMSG PHY-frame type specific fields – core part

Field	Octet	Bits	Description	Reference
BAT_ID	4	[4:0]	Bit allocation table identifier	Clause 7.1.2.3.2.9.8
BNDPL/GRP_ID		[7:5]	Bandplan identifier/subcarrier grouping identifier	Clause 7.1.2.3.2.9.9
GI_ID	5	[2:0]	Guard interval identifier	Clause 7.1.2.3.2.9.10
APSD_MAX-M		[7:3]	APSD_MAX- <u>M</u> of a BMSG frame	Clause 7.1.2.3.2.9.11
CONNECTION_ID	6	[7:0]	Connection identifier	Clause 7.1.2.3.2.9.12
RPRQ	7	[1:0]	Reply required	Clause 7.1.2.3.2.9.13
BRSTCnt		[3:2]	Burst frame count	Clause 7.1.2.3.2.9.14
BEF		[4]	Burst end flag	Clause 7.1.2.3.2.9.15
AIFG_IND		[5]	AIFG indication	Clause 7.1.2.3.2.9.16
Reserved		[6]	Reserved	Reserved for use by ITU-T G.9963 (Note 1)
EXTACKGR		[7]	Extended ACK granted	Clause 7.1.2.3.2.9.25
ACE_SYM	8	[2:0]	Number of ACE symbols	Clause 7.1.2.3.2.9.17
CNN_MNGMT		[6:3]	Connection management	Clause 7.1.2.3.2.9.18
<u>APSD_MAX-M_EXT</u> Reserved		[7]	<u>APSD_MAX-M extension</u> Reserved	<u>Clause 7.1.2.3.2.9.27</u> Reserved by ITU-T (Note 1)
BRURQ	9 and 10	[15:0]	Bandwidth reservation update request	Clause 7.1.2.3.2.9.19 (Note 2)
START_SSN	9 and 10	[15:0]	Start segment sequence number	Clause 7.1.2.3.2.9.20 (Note 3)
CURRTS	11	[6:0]	Current TS	Clause 7.1.2.3.2.9.21
Reserved		[7]	Reserved	Reserved by ITU-T (Note 1)
Reserved	12 and 13	[0]	Reserved	Reserved by ITU-T (Note 1)
BTXGL		[8:1]	Bidirectional transmission grant length	Clause 7.1.2.3.2.9.22
BTXEF		[9]	Bidirectional transmission end flag	Clause 7.1.2.3.2.9.23
P-DACK		[10]	Piggybacked Delayed Acknowledgement	Clause 7.1.2.3.2.9.26
Reserved		[15:11]	Reserved	Reserved by ITU-T (Note 1)
ACK_CE_CTRL	14	[6:0]	ACK channel estimation control	Clause 7.1.2.3.2.9.24
Reserved		[7]	Reserved	Reserved by ITU-T (Note 1)

Table 7-47 – BMSG PHY-frame type specific fields – core part

Field	Octet	Bits	Description	Reference
NOTE 1 – Bits that are reserved by ITU-T shall be set to zero by the transmitter and ignored by the receiver.				
NOTE 2 – The BRURQ field is defined when the START_SSN field is not defined.				
NOTE 3 – The START_SSN field is defined only when CNN_MNGMT = 0001, CNN_MNGMT = 0011, CNN_MNGMT = 0101 or CNN_MNGMT = 0111. Otherwise the meaning of this field is BRURQ.				

The PHY-frame header fields which are specific to the extended part of the header of the BMSG frame type are listed in Table 7-53.

7.1.2.3.2.9.1 Duration for BMSG frame (BMSG_DUR)

For a BMSG frame where Imm-ACK or a BACK does not follow the BMSG frame, the BMSG_DUR field shall contain the transmission time of the BMSG frame.

For a BMSG frame where Imm-ACK or BACK follows the BMSG frame, the BMSG_DUR field shall contain the transmission time of the BMSG frame plus the duration of the following AIFG (for Imm-Ack) or BM2BAIFG (for BACK). The BMSG_DUR field value shall not exceed 6 ms.

7.1.2.3.2.9.2 Block size (BLKSZ)

The interpretation of this field shall be as specified in clause 7.1.2.3.2.2.2, the BLKSZ field of the MSG frame.

7.1.2.3.2.9.3 FEC coding rate (FEC_RATE)

The interpretation of this field shall be as specified in clause 7.1.2.3.2.2.3, the FEC_RATE field of the MSG frame.

7.1.2.3.2.9.4 Repetitions (REP)

The interpretation of this field shall be as specified in clause 7.1.2.3.2.2.4, the REP field of the MSG frame.

7.1.2.3.2.9.5 FEC concatenation factor (FCF)

The interpretation of this field shall be as specified in clause 7.1.2.3.2.2.5, the FCF field of the MSG frame.

7.1.2.3.2.9.6 Scrambler initialization (SI)

The interpretation of this field shall be as specified in clause 7.1.2.3.2.2.6, the SI field of the MSG frame.

7.1.2.3.2.9.7 Master is detected indication (MDET)

The interpretation of this field shall be as specified in clause 7.1.2.3.2.2.7, the MDET field of the MSG frame.

7.1.2.3.2.9.8 Bit allocation table identifier (BAT_ID)

The interpretation of this field shall be as specified in clause 7.1.2.3.2.2.8, the BAT_ID field of the MSG frame.

7.1.2.3.2.9.9 Bandplan identifier/subcarrier grouping identifier (BNDPL/GRP_ID)

The interpretation of this field shall be as specified in clause 7.1.2.3.2.2.9, the BNDPL/GRP_ID field of the MSG frame.

7.1.2.3.2.9.10 Guard interval identifier (GI_ID)

The interpretation of this field shall be as specified in clause 7.1.2.3.2.2.10, the GI_ID field of the MSG frame.

7.1.2.3.2.9.11 Maximum actual PSD of BMSG frame (APSD_MAX-M)

The interpretation of this field shall be as specified in clause 7.1.2.3.2.2.11, the APSD_MAX-M field of the MSG frame.

7.1.2.3.2.9.12 Connection identifier (CONNECTION_ID)

The interpretation of this field shall be as specified in clause 7.1.2.3.2.2.12, the CONNECTION_ID field of the MSG frame.

7.1.2.3.2.9.13 Reply required (RPRQ)

The interpretation of this field shall be as specified in clause 7.1.2.3.2.2.13, the RPRQ field of the MSG frame.

7.1.2.3.2.9.14 Burst frame count (BRSTCnt)

The interpretation of this field shall be as specified in clause 7.1.2.3.2.2.14, the BRSTCnt field of the MSG frame.

7.1.2.3.2.9.15 Burst end flag (BEF)

The interpretation of this field shall be as specified in clause 7.1.2.3.2.2.15, the BEF field of the MSG frame.

7.1.2.3.2.9.16 AIFG indication (AIFG_IND)

The interpretation of this field shall be as specified in clause 7.1.2.3.2.2.16, the AIFG_IND field of the MSG frame.

7.1.2.3.2.9.17 ACE symbols (ACE_SYM)

The interpretation of this field shall be as specified in clause 7.1.2.3.2.2.17, the ACE_SYM field of the MSG frame.

7.1.2.3.2.9.18 Connection management (CNN_MNGMT)

The interpretation of this field shall be as specified in clause 7.1.2.3.2.2.18, the CNN_MNGMT field of the MSG frame.

7.1.2.3.2.9.19 Bandwidth reservation update request (BRURQ)

The interpretation of this field shall be as specified in clause 7.1.2.3.2.2.19, the BRURQ field of the MSG frame.

7.1.2.3.2.9.20 Start segment sequence number (START_SSN)

The interpretation of this field shall be as specified in clause 7.1.2.3.2.2.20, the START_SSN field of the MSG frame.

7.1.2.3.2.9.21 Current TS (CURRTS)

The interpretation of this field shall be as specified in clause 7.1.2.3.2.2.21, the CURRTS field of the MSG frame.

7.1.2.3.2.9.22 Bidirectional transmission grant length (BTXGL)

The BTXGL field shall contain the granted bidirectional transmission duration in multiples of 8 μ s. It shall be represented as an 8-bit unsigned integer.

A grant length value of zero shall indicate that bidirectional transmission is not granted. The granted duration shall encompass all transmissions from the receiver including ACK and BACK frames.

7.1.2.3.2.9.23 Bidirectional transmission end flag (BTXEF)

If the BTXEF field is set to one, it shall indicate that this is the last exchange in the current TXOP/TS.

7.1.2.3.2.9.24 ACK channel estimation control (ACK_CE_CTRL)

The interpretation of this field shall be as specified for the ACK_CE_CTRL field of the ACK frame in clause 7.1.2.3.2.3.8.

7.1.2.3.2.9.25 Extended ACK Granted (EXTACKGR)

If the EXTACKGR field is set to one, it shall indicate that this transmitter can process extended ACK and the receiver may use extended ACK as a response to the transmitted BMSG frame as described in clause 8.3.8 of [ITU-T G.9961].

7.1.2.3.2.9.26 Piggybacked Delayed Acknowledgement (P-DACK)

If the P-DACK field is set to one, it indicates that this BMSG includes delayed ACK information as described in clause 8.3.9 of [ITU-T G.9961]. It shall be set to zero otherwise.

When using bidirectional transmissions this field shall be set to zero.

7.1.2.3.2.9.27 APSD MAX-M extension

The interpretation of this field shall be as specified in clause 7.1.2.3.2.2.25, the APSD MAX-M EXT field of the MSG frame.

7.1.2.3.2.10 BACK PHY-frame type specific fields

Table 7-48 lists the fields which are specific to the core part of the PHY-frame header of the BACK frame type.

Table 7-48 – BACK PHY-frame type specific fields – core part

Field	Octet	Bits	Description	Reference
BACK_DUR	0 and 1	[15:0]	Duration for BACK frame	Clause 7.1.2.3.2.10.1
BLKSZ	2	[1:0]	Block size of FEC codeword for BACK frame payload	Clause 7.1.2.3.2.10.2
FEC_RATE		[4:2]	FEC coding rate for BACK frame payload	Clause 7.1.2.3.2.10.3
REP		[7:5]	Number of repetitions used for encoding the BACK frame payload	Clause 7.1.2.3.2.10.4
FCF	3	[2:0]	FEC concatenation factor	Clause 7.1.2.3.2.10.5
SI		[6:3]	Scrambler initialization	Clause 7.1.2.3.2.10.6
MDET		[7]	Master is detected	Clause 7.1.2.3.2.10.7
BAT_ID	4	[4:0]	Bit allocation table identifier	Clause 7.1.2.3.2.10.8
BNDPL/GRP_ID		[7:5]	Bandplan identifier/subcarrier grouping identifier	Clause 7.1.2.3.2.10.9
GI_ID	5	[2:0]	Guard interval identifier	Clause 7.1.2.3.2.10.10

Table 7-48 – BACK PHY-frame type specific fields – core part

Field	Octet	Bits	Description	Reference
APSD_MAX-M		[7:3]	APSD_MAX-M of a BACK frame	Clause 7.1.2.3.2.10.11
CONNECTION_ID	6	[7:0]	Connection identifier	Clause 7.1.2.3.2.10.12
RPRQ	7	[1:0]	Reply required	Clause 7.1.2.3.2.10.13
BRSTCnt		[3:2]	Burst frame count	Clause 7.1.2.3.2.10.14
BEF		[4]	Burst end flag	Clause 7.1.2.3.2.10.15
AIFG_IND		[5]	AIFG indication	Clause 7.1.2.3.2.10.16
Reserved		[6]	<u>APSD_MAX-M extension</u> Reserved	Clause 7.1.2.3.2.10.21 Reserved by ITU-T (Note)
<u>APSD_MAX-M_EXT</u> Reserved		[7]	Reserved	Reserved by ITU-T (Note)
ACE_SYM	8	[2:0]	Number of ACE symbols	Clause 7.1.2.3.2.10.17
CNN_MNGMT		[6:3]	Connection management	Clause 7.1.2.3.2.10.18
Reserved		[7]	Reserved	Reserved by ITU-T (Note)
BTXRL	9	[7:0]	Bidirectional transmission request length	Clause 7.1.2.3.2.10.19
ACK_CE_CTRL	10	[6:0]	ACK channel estimation control	Clause 7.1.2.3.2.10.20
Reserved		[7]	Reserved	Reserved by ITU-T (Note)
Reserved	11 to 14	[31:0]	Reserved	Reserved by ITU-T (Note)

NOTE – Bits that are reserved by ITU-T shall be set to zero by the transmitter and ignored by the receiver.

The PHY-frame header fields which are specific to the extended part of the header of the BACK frame type are listed in Table 7-54.

7.1.2.3.2.10.1 Duration for BACK frame (BACK_DUR)

For a BACK frame where Imm-ACK or a BMSG does not follow the BACK frame, the BACK_DUR field shall contain the transmission time of the BACK frame.

For a BACK frame where Imm-ACK or BMSG follows the BACK frame, the BACK_DUR field shall contain the transmission time of the BACK frame plus the duration of the following AIFG (for Imm-Ack) or BA2BMIFG (for BMSG). The BACK_DUR field value shall not exceed 6 ms.

7.1.2.3.2.10.2 Block size (BLKSZ)

The interpretation of this field shall be as specified in clause 7.1.2.3.2.2.2, the BLKSZ field of the MSG frame.

7.1.2.3.2.10.3 FEC coding rate (FEC_RATE)

The interpretation of this field shall be as specified in clause 7.1.2.3.2.2.3, the FEC_RATE field of the MSG frame.

7.1.2.3.2.10.4 Repetitions (REP)

The interpretation of this field shall be as specified in clause 7.1.2.3.2.2.4, the REP field of the MSG frame.

7.1.2.3.2.10.5 FEC concatenation factor (FCF)

The interpretation of this field shall be as specified in clause 7.1.2.3.2.2.5, the FCF field of the MSG frame.

7.1.2.3.2.10.6 Scrambler initialization (SI)

The interpretation of this field shall be as specified in clause 7.1.2.3.2.2.6, the SI field of the MSG frame.

7.1.2.3.2.10.7 Master is detected indication (MDET)

The interpretation of this field shall be as specified in clause 7.1.2.3.2.2.7, the MDET field of the MSG frame.

7.1.2.3.2.10.8 Bit allocation table identifier (BAT_ID)

The interpretation of this field shall be as specified in clause 7.1.2.3.2.2.8, the BAT_ID field of the MSG frame.

7.1.2.3.2.10.9 Bandplan identifier/subcarrier grouping identifier (BNDPL/GRP_ID)

The interpretation of this field shall be as specified in clause 7.1.2.3.2.2.9, the BNDPL/GRP_ID field of the MSG frame.

7.1.2.3.2.10.10 Guard interval identifier (GI_ID)

The interpretation of this field shall be as specified in clause 7.1.2.3.2.2.10, the GI_ID field of the MSG frame.

7.1.2.3.2.10.11 Maximum actual PSD of BACK frame (APSD_MAX-M)

The interpretation of this field shall be as specified in clause 7.1.2.3.2.2.11, the APSD_MAX-M field of the MSG frame.

7.1.2.3.2.10.12 Connection identifier (CONNECTION_ID)

The interpretation of this field shall be as specified in clause 7.1.2.3.2.2.12, the CONNECTION_ID field of the MSG frame.

7.1.2.3.2.10.13 Reply required (RPRQ)

The interpretation of this field shall be as specified in clause 7.1.2.3.2.2.13, the RPRQ field of the MSG frame.

7.1.2.3.2.10.14 Burst frame count (BRSTCnt)

The interpretation of this field shall be as specified in clause 7.1.2.3.2.2.14, the BRSTCnt field of the MSG frame.

7.1.2.3.2.10.15 Burst end flag (BEF)

The interpretation of this field shall be as specified in clause 7.1.2.3.2.2.15, the BEF field of the MSG frame.

7.1.2.3.2.10.16 AIFG indication (AIFG_IND)

The interpretation of this field shall be as specified in clause 7.1.2.3.2.2.16, the AIFG_IND field of the MSG frame.

7.1.2.3.2.10.17 ACE symbols (ACE_SYM)

The interpretation of this field shall be as specified in clause 7.1.2.3.2.2.17, the ACE_SYM field of the MSG frame.

7.1.2.3.2.10.18 Connection management (CNN_MNGMT)

The interpretation of this field shall be as specified in clause 7.1.2.3.2.2.18, the CNN_MNGMT field of the MSG frame.

7.1.2.3.2.10.19 Bidirectional transmission request length (BTXRL)

The BTXRL field shall contain the requested bidirectional transmission duration in multiples of 8 μ s. It shall be represented as an 8-bit unsigned integer. A request length value of zero shall indicate that the acknowledging node is not requesting bidirectional transmission.

7.1.2.3.2.10.20 ACK channel estimation control (ACK_CE_CTRL)

The interpretation of this field shall be as specified for the ACK_CE_CTRL field of the ACK frame in clause 7.1.2.3.2.3.8.

7.1.2.3.2.11 ACTMG PHY-frame type specific fields

Table 7-49 lists the PHY-frame header fields which are specific to the ACTMG frame type.

Table 7-49 – ACTMG PHY-frame type specific fields

Field	Octet	Bits	Description	Reference
CTMGACK	0 to 14	[0]	CTMG acknowledgment	Clause 7.1.2.3.2.11.1
Reserved		[119:1]	Reserved	Reserved by ITU-T (Note)

NOTE – Bits that are reserved by ITU-T shall be set to zero by the transmitter and ignored by the receiver.

An ACTMG frame shall be sent following a CTMG frame that has its IACKRQ field set to one (see clause 7.1.2.3.2.6.1) indicating that immediate acknowledgment is required.

7.1.2.3.2.11.1 CTMG acknowledgment (CTMGACK)

The CTMGACK field shall indicate the correct reception of the previously received CTMG frame that requested an immediate acknowledgment (see clause 7.1.2.3.2.6.1).

This field shall be set to one only if both the HCS of the core part and E_HCS of the extended part (if present) of the PHY-frame header of the CTMG frame are correct.

7.1.2.3.2.12 Reserved

Reserved by ITU-T.

7.1.2.3.2.13 Reserved

Reserved by ITU-T.

7.1.2.3.2.14 Reserved

Reserved by ITU-T.

7.1.2.3.2.15 Reserved

Reserved by ITU-T.

7.1.2.3.2.16 FTE PHY-frame type specific fields

This frame type is used for adding additional frame types (i.e., frame type extension).

Table 7-50 lists the PHY-frame header fields which are specific to the FTE frame type.

Table 7-50 – FTE PHY-frame type specific fields

Field	Octet	Bits	Description	Reference
FTE_DUR	0 and 1	[15:0]	Duration for FTE frame	Clause 7.1.2.3.2.16.1
CURRTS	2	[6:0]	Current TS	Clause 7.1.2.3.2.16.3
Reserved		[7]	Reserved	Reserved by ITU-T (Note)
EFT_FLD	3 to 14	[95:0]	EFT specific fields	Clause 7.1.2.3.2.16.2
NOTE – Bits that are reserved by ITU-T shall be set to zero by the transmitter and ignored by the receiver.				

7.1.2.3.2.16.1 Duration for FTE frame (FTE_DUR)

The FTE_DUR field shall contain the duration of a single PHY frame sequence in multiples of 0.25 μ s. It shall be represented as a 16-bit unsigned integer. This field shall only be present if DRI = 1.

7.1.2.3.2.16.2 EFT specific fields (EFT_FLD)

This clause describes the fields that are specific to FTE frame type. The first field shall be a fixed-length subfield that identifies an extended frame type (EFT). The size of the EFT and other fields following the EFT are for further study.

7.1.2.3.2.16.3 Current TS (CURRTS)

The interpretation of this field shall be as specified in clause 7.1.2.3.2.2.21, the CURRTS field of the MSG frame.

7.1.2.3.3 Extended header fields

The extended part of the PHY-frame header is PHY_H bits long and shall be composed of a common part and a variable part. The common part shall contain fields that are common to all PHY frame types. The variable part shall contain fields according to the PHY frame type. PHY frame type shall be indicated by the FT field in the core part of the PHY-frame header. The PAD fields shall fit the length of the header of different PHY frame types to the standard values of PHY_H bits. The content of the extended part shall be protected by the 16-bit header check sequence (E_HCS).

The fields of the extended part of the PHY-frame header are defined in Table 7-51.

Table 7-51 – Extended part of PHY-frame header

Field	Octet	Bits	Description	
E_FTSF	0 to 18	[151:0]	Extended header frame-type specific fields	Variable part
E_HCS	19 and 20	[15:0]	Extended header check sequence	Common part

7.1.2.3.3.1 Extended header frame-type specific fields (E_FTSF)

7.1.2.3.3.1.1 E_FTSF for a CTMG PHY frame

Table 7-52 lists the E_FTSF for a CTMG PHY frame.

Table 7-52 – E_FTSF for a CTMG PHY frame type

Field	Octet	Bits	Description	Reference
CTMGD_EXT	0 to 18	[151:0]	CTMG data extension	Clause 7.1.2.3.3.1.1.1

7.1.2.3.3.1.1.1 CTMG data extension (CTMGD_EXT)

This field is the extension of the CTMGD field. It shall be coded as described in clause 7.1.2.3.2.6.2.

7.1.2.3.3.1.2 E_FTSF for a BMSG PHY frame

Table 7-53 lists the E_FTSF for a BMSG PHY frame.

Table 7-53 – E_FTSF for a BMSG PHY frame type

Field	Octet	Bits	Description	Reference
RXRST_DATA	0 and 1	[0]	Data RX reset flag	Clause 7.1.2.3.3.1.2.1
RXRST_MNGMT		[1]	Management RX reset flag	Clause 7.1.2.3.3.1.2.2
FLCTRLT		[2]	Flow control type	Clause 7.1.2.3.3.1.2.3
FLCTRL		[7:3]	Flow control	Clause 7.1.2.3.3.1.2.4
Reserved		[8]	Reserved	Reserved by ITU-T (Note)
FLCTRL_CONN		[9]	Flow control connection flag	Clause 7.1.2.3.3.1.2.5
Reserved		[15:10]	Reserved	Reserved by ITU-T (Note)
ACKDATA_BM	2 to 13	[90:0]	Acknowledgement data of the BMSG frame	Clause 7.1.2.3.3.1.2.6
Reserved		[95:91]	Reserved	Reserved by ITU-T (Note)
Reserved	14 to 18	[39:0]	Reserved	Reserved by ITU-T (Note)
NOTE – Bits that are reserved by ITU-T shall be set to zero by the transmitter and ignored by the receiver.				

7.1.2.3.3.1.2.1 Data RX reset flag (RXRST_DATA)

The interpretation of this field shall be as specified in clause 7.1.2.3.2.3.5, the RXRST_DATA field of the ACK frame.

7.1.2.3.3.1.2.2 Management RX reset flag (RXRST_MNGMT)

The interpretation of this field shall be as specified in clause 7.1.2.3.2.3.6, RXRST_MNGMT field of the ACK frame.

7.1.2.3.3.1.2.3 Flow control type (FLCTRLT)

The interpretation of this field shall be as specified in clause 7.1.2.3.2.3.2, the FLCTRLT field of the ACK frame.

7.1.2.3.3.1.2.4 Flow control (FLCTRL)

The interpretation of this field shall be as specified in clause 7.1.2.3.2.3.3, the FLCTRL field of the ACK frame.

7.1.2.3.3.1.2.5 Flow control connection flag (FLCTRL_CONN)

The interpretation of this field shall be as specified in clause 7.1.2.3.2.3.1, the FLCTRL_CONN field of the ACK frame.

7.1.2.3.3.1.2.6 Acknowledgement data of the BMSG frame (ACKDATA_BM)

The interpretation of this field shall be as specified in clause 7.1.2.3.2.3.9, the ACKDATA/MACK_D field of the ACK frame for unicast acknowledgment (MI = 0).

7.1.2.3.3.1.3 E_FTSF for a BACK PHY frame

Table 7-54 lists the E_FTSF for a BACK PHY frame.

Table 7-54 – E_FTSF for a BACK PHY frame type

Field	Octet	Bits	Description	Reference
RXRST_DATA	0 and 1	[0]	Data RX reset flag	Clause 7.1.2.3.2.10.21
RXRST_MNGMT		[1]	Management RX reset flag	Clause 7.1.2.3.2.10.22
FLCTRLT		[2]	Flow control type	Clause 7.1.2.3.2.10.23
FLCTRL		[7:3]	Flow control	Clause 7.1.2.3.2.10.24
Reserved		[8]	Reserved	Reserved by ITU-T (Note)
FLCTRL_CONN		[9]	Flow control connection flag	Clause 7.1.2.3.2.10.25
Reserved		[15:10]	Reserved	Reserved by ITU-T (Note)
ACKDATA_BA	2 to 13	[90:0]	Acknowledgement data of the BACK frame	Clause 7.1.2.3.2.10.26
Reserved		[95:91]	Reserved	Reserved by ITU-T (Note)
Reserved	14 to 18	[39:0]	Reserved	Reserved by ITU-T (Note)

NOTE – Bits that are reserved by ITU-T shall be set to zero by the transmitter and ignored by the receiver.

7.1.2.3.3.1.3.1 Data RX reset flag (RXRST_DATA)

The interpretation of this field shall be as specified in clause 7.1.2.3.2.3.5, the RXRST_DATA field of the ACK frame.

7.1.2.3.3.1.3.2 Management RX reset flag (RXRST_MNGMT)

The interpretation of this field shall be as specified in clause 7.1.2.3.2.3.6, the RXRST_MNGMT field of the ACK frame.

7.1.2.3.3.1.3.3 Flow control type (FLCTRLT)

The interpretation of this field shall be as specified in clause 7.1.2.3.2.3.2, the FLCTRLT field of the ACK frame.

7.1.2.3.3.1.3.4 Flow control (FLCTRL)

The interpretation of this field shall be as specified in clause 7.1.2.3.2.3.3, the FLCTRL field of the ACK frame.

7.1.2.3.3.1.3.5 Flow control connection flag (FLCTRL_CONN)

The interpretation of this field shall be as specified in clause 7.1.2.3.2.3.1, the FLCTRL_CONN field of the ACK frame.

7.1.2.3.3.1.3.6 Acknowledgement data of the BACK frame (ACKDATA_BA)

The interpretation of this field shall be as specified in clause 7.1.2.3.2.3.9, the ACKDATA/MCACK_D field of the ACK frame for unicast acknowledgment (MI = 0).

7.1.2.3.3.1.4 E_FTSF for ACK PHY-frame

Table 7-54.1 lists the E_FTSF for ACK PHY frame.

Table 7-54.1 – E_FTSF for ACK PHY frame type

Field	Octet	Bits	Description	Reference
ACKI_EXT	0 to 17	[143:0]	ACKI field extension	Clause 7.1.2.3.3.1.4.1
Reserved	18	[7:0]	Reserved	Reserved by ITU-T

7.1.2.3.3.1.4.1 ACKI field extension (ACKI_EXT)

This field is the extension of the ACKI field, and shall be concatenated to the ACKI field of the core part of the PHY-frame header of the ACK frame before decoding the reception status of data units as described in clause 7.1.2.3.2.3.9.1.7.

7.1.2.3.3.2 Extended header check sequence (E_HCS)

The E_HCS field is intended for verification of the extended part of the PHY-frame header. The E_HCS is a 16-bit cyclic redundancy check (CRC) and shall be computed over all the fields of the E_FTSF in the order that they are transmitted, starting with the LSB of the first field and ending with the MSB of the last field of E_FTSF. The same polynomial as specified in clause 7.1.2.3.1.9 shall be used.

7.1.3 Physical medium attachment (PMA) sublayer

The functional model of the PMA is presented in Figure 7-5. It is intended to describe in more detail the PMA functional block presented in Figure 7-1.

In the transmit direction, the incoming PHY frame (except for preamble and channel estimation symbols) at the α -reference point has a format as defined in clause 7.1.2. Both the header bits and the payload bits of the incoming frame are scrambled as described in clause 7.1.3.1. The header bits of the incoming frame are encoded as described in clause 7.1.3.4. The payload bits are encoded, as described in clause 7.1.3.3. The parameters of payload encoder are controlled by the PHY management entity.

After encoding, the header and payload are each segmented into an integer number of symbol frames as described in clause 7.1.3.5.1. The obtained symbol frames of the header and the payload are submitted to the PMD (at the δ -reference point) for modulation and transmission over the medium.

In the receive direction, all necessary inverse operations of decoding, and de-scrambling are performed on the received symbol frames. The recovered PHY-frame header and payload are submitted to the α -reference point for further processing in the PCS.

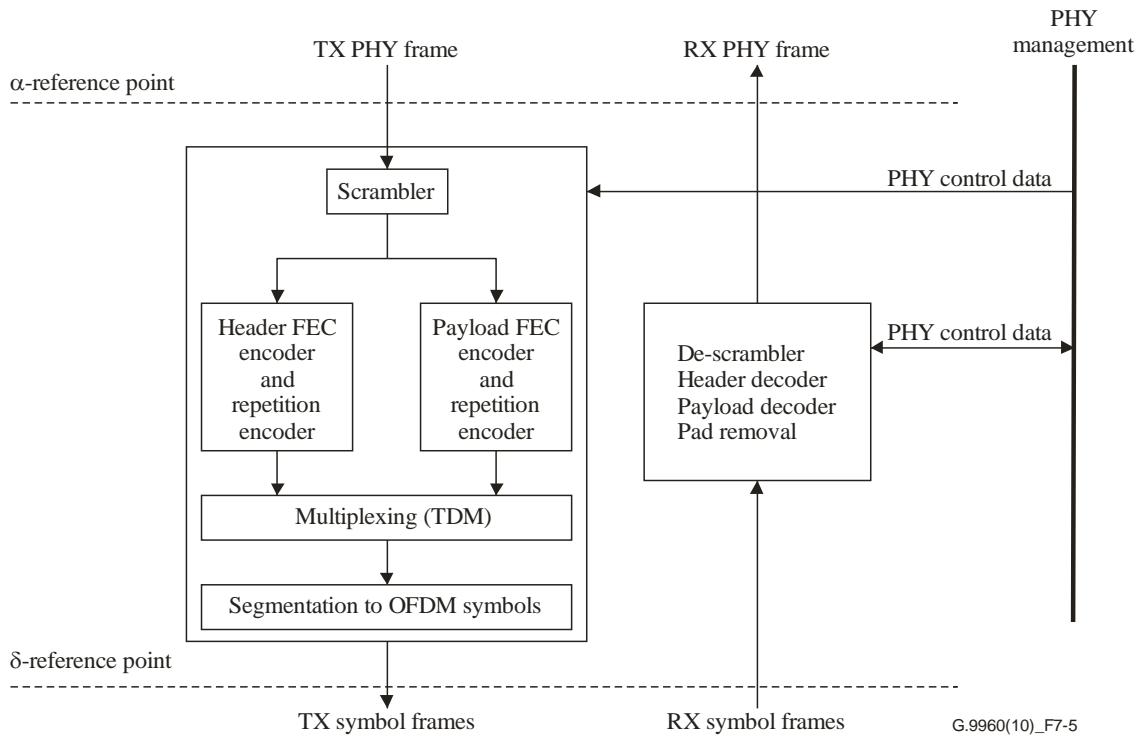

Figure 7-5 – Functional model of PMA sublayer

7.1.3.1 Scrambling

All data starting from the first bit of the PHY-frame header (PFH) and ending by the last bit of the payload shall be scrambled with a pseudorandom sequence generated by the linear feedback shift register (LFSR) with the polynomial $p(x) = x^{23} + x^{18} + 1$, as shown in Figure 7-6.

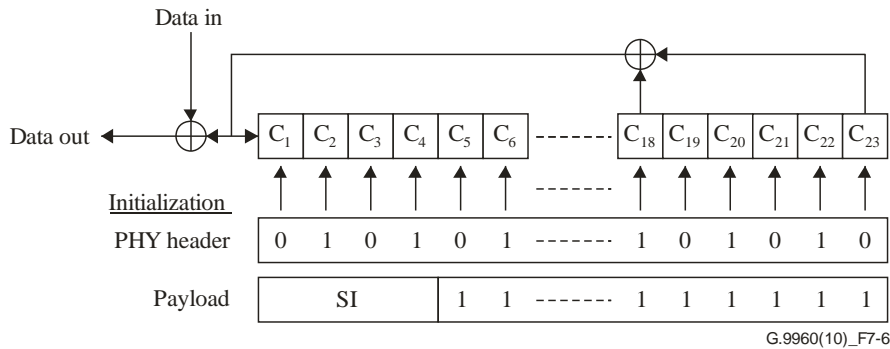

Figure 7-6 – Scrambler; $p(x) = x^{23} + x^{18} + 1$

The LFSR generator shall be initialized at the first bit of the header with the initialization vector equal to 2AAAAA₁₆ (where the LSB corresponds to C₁); this initialization is used for the scrambling of the header data. If the SI field in the PHY-frame header is not equal to zero, a second initialization shall be performed for payload data, immediately after the last bit of the header is read from the scrambler and before the first bit of the payload is read from the scrambler. For the second initialization, the first four bits of the LFSR (C₁ to C₄) shall be set to the value of SI (scrambler initialization), while all other bits C₅ to C₂₃ shall be initialized to 1. The value of SI = C₄C₃C₂C₁ is communicated in the header as described in clause 7.1.2.3.

The first bit to be scrambled shall be XOR'ed with the first bit generated by the LFSR after initialization (i.e., C₁₈ ⊕ C₂₃ of the initialization vector). See Annex G for examples.

The special value 0₁₆ for SI indicates that the scrambler is not re-initialized between the header and payload. The initialization of the SI field to values other than the special value is optional.

NOTE – The method for generating SI values is beyond the scope of this Recommendation.

7.1.3.2 FEC encoding

The FEC encoding scheme is shown in Figure 7-7. The scheme consists of a systematic QC-LDPC-BC encoder and a puncturing mechanism. The parameters of the FEC encoding scheme are:

- the number of incoming information bits, K (information block of bits);
- the number of coded bits, N_M (coded block of bits);
- the number of parity-check bits, $N_M - K$;
- the number of output bits, $N_{FEC} \leq N_M$, (FEC codeword, whose size depends on the puncturing pattern);
- the mother code rate, $R_M = K/N_M$, defined as the code rate before puncturing;
- the code rate, $R = K/N_{FEC}$, defined as the code rate after puncturing.

The information block size shall be one of the values specified in Table 7-56.

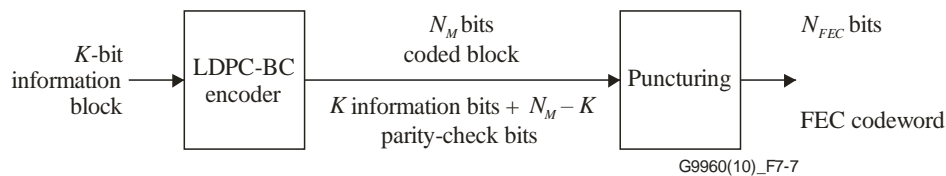

Figure 7-7 – FEC encoder

The encoder shall support mother codes with rates $R_M = 1/2$, $R_M = 2/3$ and $R_M = 5/6$. From these mother codes, codes with higher code rates shall be obtained through puncturing, as described in clause 7.1.3.2.2. The puncturing block shall support patterns providing all code rates presented in Table 7-56.

The codeword at the output of the puncturing block is of size $N_{FEC} \leq N_M$. The bits shall be output in the ascending order of codeword indices determined by vector \mathbf{v}' (see clause 7.1.3.2.2); with this order the first information bit input to the encoder will be the first at the output of the puncturing.

7.1.3.2.1 LDPC-BC encoder

The code rate of the mother code, $R_M = K/N_M$, is determined by a $(N_M - K) \times N_M$ size parity-check matrix \mathbf{H} composed by an array of $c \times t$ circulant $b \times b$ sub-matrices $\mathbf{A}_{i,j}$:

$$\mathbf{H} = \begin{bmatrix} \mathbf{A}_{1,1} & \mathbf{A}_{1,2} & \cdots & \mathbf{A}_{1,t} \\ \mathbf{A}_{2,1} & \mathbf{A}_{2,2} & \cdots & \mathbf{A}_{2,t} \\ \vdots & \vdots & \ddots & \vdots \\ \mathbf{A}_{c,1} & \mathbf{A}_{c,2} & \cdots & \mathbf{A}_{c,t} \end{bmatrix}$$

The parameters c, t ($0 < c \leq t$) imply a rate $R_M = (t - c)/t$. By selecting different sets of c, t , different rates can be obtained.

The sub-matrices $\mathbf{A}_{i,j}$ are either a rotated identity or a zero matrix and have a size of $b \times b$, where parameter $b = N_M/t$ is called the expansion factor of \mathbf{H} and controls the code block size, N_M .

The parity-check matrix, \mathbf{H} , is described in its compact form:

$$\mathbf{H}_c = \begin{bmatrix} a_{1,1} & a_{1,2} & \cdots & a_{1,t} \\ a_{2,1} & a_{2,2} & \cdots & a_{2,t} \\ \vdots & \vdots & \ddots & \vdots \\ a_{c,1} & a_{c,2} & \cdots & a_{c,t} \end{bmatrix}$$

A zero sub-matrix in position (i,j) is labelled with $a_{i,j} = -1$, and a rotated identity sub-matrix is labelled with a positive integer number $a_{i,j}$ defining the number of right column shifts of the identity matrix.

This Recommendation defines one matrix for each mother code rate and block size.

The compact form \mathbf{H}_c of parity-check matrix $(1/2)_H$ corresponding to mother code with rate $R_M = 1/2$ ($t = 24, c = 12$) and number of coded bits $N_M = 336$ shall be:

-1	-1	-1	6	-1	-1	9	6	-1	-1	2	-1	-1	0	-1	-1	-1	-1	-1	-1	-1	-1	-1
-1	0	-1	-1	-1	3	-1	12	1	-1	-1	3	-1	0	0	-1	-1	-1	-1	-1	-1	-1	-1
-1	9	11	-1	-1	13	-1	-1	2	12	-1	-1	-1	-1	0	0	-1	-1	-1	-1	-1	-1	-1
1	-1	-1	11	-1	-1	7	-1	-1	-1	11	-1	-1	-1	-1	0	0	-1	-1	-1	-1	-1	-1
-1	-1	-1	4	8	-1	-1	-1	-1	-1	2	5	4	-1	-1	-1	0	0	-1	-1	-1	-1	-1
-1	3	0	-1	-1	8	-1	-1	1	-1	-1	-1	-1	-1	-1	-1	0	0	-1	-1	-1	-1	-1
-1	-1	-1	0	6	-1	-1	-1	-1	5	13	-1	-1	-1	-1	-1	-1	0	0	-1	-1	-1	-1
-1	-1	-1	9	-1	-1	-1	3	-1	-1	3	1	-1	-1	-1	-1	-1	-1	0	0	-1	-1	-1
9	0	13	-1	-1	12	-1	-1	8	-1	-1	-1	-1	-1	-1	-1	-1	-1	-1	0	0	-1	-1
-1	5	-1	-1	1	4	-1	-1	5	-1	-1	-1	-1	-1	-1	-1	-1	-1	-1	-1	0	0	-1
-1	-1	-1	8	-1	-1	8	-1	-1	9	0	-1	0	-1	-1	-1	-1	-1	-1	-1	-1	0	0
10	11	-1	-1	-1	3	-1	-1	0	-1	-1	-1	4	8	-1	-1	-1	-1	-1	-1	-1	-1	-1

The compact form \mathbf{H}_c of parity-check matrix $(1/2)_S$ corresponding to mother code with rate $R_M = 1/2$ ($t = 24, c = 12$) and number of coded bits $N_M = 1920$ shall be:

27	-1	-1	-1	55	19	-1	30	-1	-1	-1	-1	-1	0	-1	-1	-1	-1	-1	-1	-1	-1	-1
-1	-1	0	-1	1	-1	70	-1	47	-1	62	-1	-1	0	0	-1	-1	-1	-1	-1	-1	-1	-1
-1	-1	41	-1	-1	-1	44	-1	-1	59	60	25	-1	-1	0	0	-1	-1	-1	-1	-1	-1	-1
16	77	-1	-1	-1	5	-1	48	-1	-1	-1	-1	-1	-1	0	0	-1	-1	-1	-1	-1	-1	-1
-1	-1	-1	45	-1	27	-1	46	19	-1	-1	-1	-1	-1	-1	0	0	-1	-1	-1	-1	-1	-1
-1	-1	63	-1	-1	-1	55	-1	-1	-1	48	26	10	-1	-1	-1	-1	0	0	-1	-1	-1	-1
-1	-1	-1	42	-1	21	-1	58	-1	41	-1	-1	-1	-1	-1	-1	-1	0	0	-1	-1	-1	-1
-1	-1	-1	-1	78	0	-1	7	52	-1	-1	-1	-1	-1	-1	-1	-1	-1	0	0	-1	-1	-1
-1	29	9	-1	-1	-1	37	-1	-1	-1	35	21	-1	-1	-1	-1	-1	-1	-1	0	0	-1	-1
-1	-1	22	72	-1	-1	47	-1	-1	-1	0	-1	-1	-1	-1	-1	-1	-1	-1	-1	0	0	-1
35	-1	-1	-1	-1	13	-1	35	-1	70	-1	-1	0	-1	-1	-1	-1	-1	-1	-1	-1	0	0
-1	46	28	-1	-1	-1	38	-1	-1	-1	8	-1	10	58	-1	-1	-1	-1	-1	-1	-1	-1	-1

The compact form \mathbf{H}_c of parity-check matrix $(1/2)_L$ corresponding to mother code with rate $R_M = 1/2$ ($t = 24, c = 12$) and number of coded bits $N_M = 8640$ shall be:

-1	34	-1	95	-1	279	-1	-1	-1	-1	248	-1	-1	0	-1	-1	-1	-1	-1	-1	-1	-1	-1
-1	-1	0	-1	0	-1	-1	-1	-1	134	356	275	-1	0	0	-1	-1	-1	-1	-1	-1	-1	-1
51	-1	27	-1	-1	-1	-1	-1	22	152	-1	57	-1	-1	0	0	-1	-1	-1	-1	-1	-1	-1
-1	124	-1	290	-1	281	15	-1	-1	-1	-1	-1	-1	-1	0	0	-1	-1	-1	-1	-1	-1	-1
-1	340	-1	99	336	-1	-1	1	-1	-1	-1	-1	33	-1	-1	-1	0	0	-1	-1	-1	-1	-1
163	-1	46	-1	-1	-1	-1	-1	-1	306	-1	86	-1	-1	-1	-1	-1	0	0	-1	-1	-1	-1
-1	185	-1	24	-1	-1	-1	94	0	-1	-1	-1	-1	-1	-1	-1	-1	-1	0	0	-1	-1	-1
-1	223	-1	225	325	-1	-1	-1	-1	-1	297	-1	-1	-1	-1	-1	-1	-1	-1	0	0	-1	-1
46	-1	314	-1	-1	-1	59	-1	-1	67	-1	120	-1	-1	-1	-1	-1	-1	-1	-1	0	0	-1
-1	-1	121	-1	-1	-1	-1	161	-1	303	-1	264	-1	-1	-1	-1	-1	-1	-1	-1	0	0	-1
-1	303	-1	8	-1	185	-1	-1	138	-1	-1	-1	0	-1	-1	-1	-1	-1	-1	-1	-1	0	0
-1	-1	312	-1	-1	-1	100	-1	-1	144	-1	307	33	166	-1	-1	-1	-1	-1	-1	-1	-1	0

The compact form H_c of parity-check matrix $(2/3)_S$ corresponding to mother code with rate $R_M = 2/3$ ($t = 24, c = 8$) and number of coded bits $N_M = 1440$ shall be:

```

49 -1 -1 21 31 -1 57 -1 -1 19 -1 29 2 -1 19 -1 -1 0 -1 -1 -1 -1 -1
-1 7 22 -1 -1 37 -1 32 10 -1 26 -1 -1 59 -1 48 -1 0 0 -1 -1 -1 -1 -1
53 -1 -1 20 50 -1 -1 3 16 -1 49 -1 -1 28 14 -1 -1 -1 0 0 -1 -1 -1 -1
-1 58 23 -1 -1 15 54 -1 -1 5 -1 18 49 -1 -1 13 -1 -1 -1 0 0 -1 -1 -1
55 -1 -1 58 -1 9 -1 26 57 -1 41 -1 31 -1 21 -1 -1 -1 -1 -1 0 0 -1 -1
-1 10 49 -1 59 -1 7 -1 -1 30 -1 18 -1 48 -1 7 59 -1 -1 -1 -1 0 0 -1
48 -1 -1 50 18 -1 -1 11 52 -1 59 -1 -1 37 -1 10 0 -1 -1 -1 -1 -1 0 0
-1 24 16 -1 -1 0 53 -1 -1 41 -1 38 51 -1 58 -1 59 8 -1 -1 -1 -1 -1 0

```

The compact form H_c of parity-check matrix $(2/3)_L$ corresponding to mother code with rate $R_M = 2/3$ ($t = 24, c = 8$) and number of coded bits $N_M = 6480$ shall be:

```

78 -1 -1 167 237 -1 3 -1 266 -1 -1 102 153 -1 -1 212 -1 0 -1 -1 -1 -1 -1
-1 83 189 -1 -1 68 -1 178 -1 90 205 -1 -1 13 4 -1 -1 0 0 -1 -1 -1 -1
-1 226 147 -1 46 -1 -1 76 -1 116 -1 211 -1 112 -1 118 -1 -1 0 0 -1 -1 -1
92 -1 -1 214 -1 236 241 -1 157 -1 143 -1 214 -1 207 -1 -1 -1 -1 0 0 -1 -1
144 -1 -1 258 264 -1 53 -1 114 -1 172 -1 -1 82 262 -1 62 -1 -1 -1 0 0 -1
-1 153 120 -1 -1 199 -1 126 -1 61 -1 183 15 -1 -1 134 -1 -1 -1 -1 0 0 -1
-1 100 -1 141 -1 36 -1 17 -1 156 -1 124 162 -1 -1 57 0 -1 -1 -1 -1 0 0
196 -1 187 -1 73 -1 80 -1 139 -1 57 -1 -1 236 267 -1 62 256 -1 -1 -1 -1 -1 0

```

The compact form H_c of parity-check matrix $(5/6)_S$ corresponding to mother code with rate $R_M = 5/6$ ($t = 24, c = 4$) and number of coded bits $N_M = 1152$ shall be:

```

-1 13 32 47 41 24 -1 25 22 40 1 31 8 15 20 15 42 30 13 3 -1 0 -1 -1
25 46 15 43 45 29 39 47 23 38 39 12 -1 21 -1 38 33 0 0 -1 39 0 0 -1
35 45 45 38 14 16 6 11 -1 18 7 41 35 17 32 45 41 -1 18 17 0 -1 0 0
9 32 6 22 26 31 9 8 22 32 40 4 18 40 36 -1 -1 23 31 41 39 20 -1 0

```

The compact form H_c of parity-check matrix $(5/6)_L$ corresponding to mother code with rate $R_M = 5/6$ ($t = 24, c = 4$) and number of coded bits $N_M = 5184$ shall be:

```

-1 47 146 203 184 112 -1 116 103 181 3 140 38 68 91 70 191 138 62 14 -1 0 -1 -1
117 203 67 194 206 133 174 212 104 171 176 56 -1 96 -1 167 149 4 1 -1 177 0 0 -1
153 206 198 173 55 72 28 53 -1 82 34 186 161 80 144 204 187 -1 84 77 0 -1 0 0
44 147 27 83 118 130 41 38 100 146 183 19 85 180 163 -1 -1 106 140 185 177 94 -1 0

```

7.1.3.2.1.1 Encoding operation

The encoder shall support the coded block sizes and rates presented in Table 7-56. The parity-check matrix \mathbf{H} used to encode a block of information bits is selected according to the mother code indicated in Table 7-56.

The encoding process shall be as follows:

- 1) A group of incoming K information bits $\mathbf{u} = [u_0, u_1, \dots, u_{K-1}]$ are collected and copied to the output of the encoder to form a block of systematic code bits.
- 2) $N_M - K$ parity-check bits, $\mathbf{p} = [p_0, \dots, p_{N_M - K - 1}]$, are computed using the parity-check matrix \mathbf{H} and the information block \mathbf{u} . The resulting coded block $\mathbf{v} = [\mathbf{u} | \mathbf{p}]$ shall satisfy the parity check equations $\mathbf{v}\mathbf{H}^T = \mathbf{0}$. Here $\mathbf{0}$ is a zero row vector of dimension $N_M - K$.
- 3) The $N_M - K$ parity check bits \mathbf{p} are copied to the output of the encoder as a block of parity-check bits $\mathbf{p} = [p_0, \dots, p_{N_M - K - 1}]$ to form the output coded block $\mathbf{v} = [\mathbf{u} | \mathbf{p}] = [v_0, v_1, \dots, v_{N_M - 1}]$.

4) The output of the encoder \mathbf{v} is the input to the puncturing block (see Figure 7-7).

NOTE – One method of encoding is to determine a systematic generator matrix \mathbf{G} from \mathbf{H} such that $\mathbf{GH}^T = \mathbf{0}$. A K -bit information block $\mathbf{u} = [u_0, u_1, \dots, u_{K-1}]$ can be encoded by the systematic generator matrix \mathbf{G} via the operation $\mathbf{v} = \mathbf{uG}$ to become a N_M -bit coded block $\mathbf{v} = [v_0, v_1, \dots, v_{N_M-1}] = [\mathbf{u} | \mathbf{p}]$, where $\mathbf{p} = [p_0, \dots, p_{N_M-K-1}]$ are the parity-check bits. Encoding an LDPC code from \mathbf{G} can be quite complex. However, the QC-LDPC-BC codes specified here are such that very low complexity encoding directly from \mathbf{H} is possible.

7.1.3.2.2 Puncturing

Puncturing shall discard some of the coded block bits to achieve a higher code rate (R). Puncturing is applied to both information and parity-check bits. The puncturing block uses the puncturing patterns specified in Table 7-55. The puncturing patterns are denoted as $\mathbf{pp}_T^{(i)}$, where T is the length of the puncturing pattern and i is the number of zeros in the pattern.

Table 7-55 – Puncturing patterns

	Puncturing pattern
$\mathbf{pp}_{16}^{(0)}$	[1 1 1 1 1 1 1 1 1 1 1 1 1 1 1 1]
$\mathbf{pp}_{1152}^{(72)}$	$\underbrace{[1 \ 1 \ \dots \ 1 \ 0 \ 0 \ \dots \ 0 \ 1 \ 1 \ \dots \ 1 \ 0 \ 0 \ \dots \ 0]}_{720} \underbrace{\quad}_{36} \underbrace{\quad}_{360} \underbrace{\quad}_{36}$
$\mathbf{pp}_{5184}^{(324)}$	$\underbrace{[1 \ 1 \ \dots \ 1 \ 0 \ 0 \ \dots \ 0 \ 1 \ 1 \ \dots \ 1 \ 0 \ 0 \ \dots \ 0 \ 1 \ 1 \ \dots \ 1]}_{3240} \underbrace{\quad}_{162} \underbrace{\quad}_{972} \underbrace{\quad}_{162} \underbrace{\quad}_{648}$
$\mathbf{pp}_{1152}^{(144)}$	$\underbrace{[1 \ 1 \ \dots \ 1 \ 0 \ 0 \ \dots \ 0 \ 1 \ 1 \ \dots \ 1 \ 0 \ 0 \ \dots \ 0 \ 1 \ 1 \ \dots \ 1]}_{720} \underbrace{\quad}_{48} \underbrace{\quad}_{240} \underbrace{\quad}_{96} \underbrace{\quad}_{48}$
$\mathbf{pp}_{5184}^{(648)}$	$\underbrace{[0 \ 0 \ \dots \ 0 \ 1 \ 1 \ \dots \ 1 \ 0 \ 0 \ \dots \ 0 \ 1 \ 1 \ \dots \ 1]}_{216} \underbrace{\quad}_{4320} \underbrace{\quad}_{432} \underbrace{\quad}_{216}$

NOTE – The pattern $\mathbf{pp}_{16}^{(0)}$ does not result in any code rate changes and is introduced to be consistent with the puncturing notation.

The coded block \mathbf{v} input to the puncturing block shall be processed using the puncturing pattern $\mathbf{pp}_T^{(i)}$ as follows:

For the pattern $\mathbf{pp}_T^{(i)} = [pp_0^{(i)}, \dots, pp_{T-1}^{(i)}]$, the puncturing block shall omit all incoming coded bits $v_t, t = 0, \dots, N_M - 1$ for which $pp_{t \bmod T}^{(i)} = 0$. Hence, the resulting output FEC codeword will be $\mathbf{v}' = [v'_0, v'_1, \dots, v'_{N_{FEC}-1}]$ with $N_{FEC} \leq N_M$.

7.1.3.2.3 FEC encoding parameters

The FEC encoding scheme shall support the encoding parameters specified in Table 7-56.

Table 7-56 – FEC encoding parameters

	Code rate, R	Information block size, K	Puncturing pattern, pp	Mother code matrix	FEC codeword size, N_{FEC}
For header	1/2	PHY _H = 168	$pp_{16}^{(0)}$	(1/2) _H	336
For payload	1/2	960	$pp_{16}^{(0)}$	(1/2) _S	1920
	1/2	4320	$pp_{16}^{(0)}$	(1/2) _L	8640
	2/3	960	$pp_{16}^{(0)}$	(2/3) _S	1440
	2/3	4320	$pp_{16}^{(0)}$	(2/3) _L	6480
	5/6	960	$pp_{16}^{(0)}$	(5/6) _S	1152
	5/6	4320	$pp_{16}^{(0)}$	(5/6) _L	5184
	16/18	960	$pp_{1152}^{(72)}$	(5/6) _S	1080
	16/18	4320	$pp_{5184}^{(324)}$	(5/6) _L	4860
	20/21	960	$pp_{1152}^{(144)}$	(5/6) _S	1008
	20/21	4320	$pp_{5184}^{(648)}$	(5/6) _L	4536

7.1.3.3 Payload encoding

The functional model of the payload encoder is presented in Figure 7-8. It contains an FEC encoder and a payload repetition encoder (PRE) to support robust communication mode (RCM).

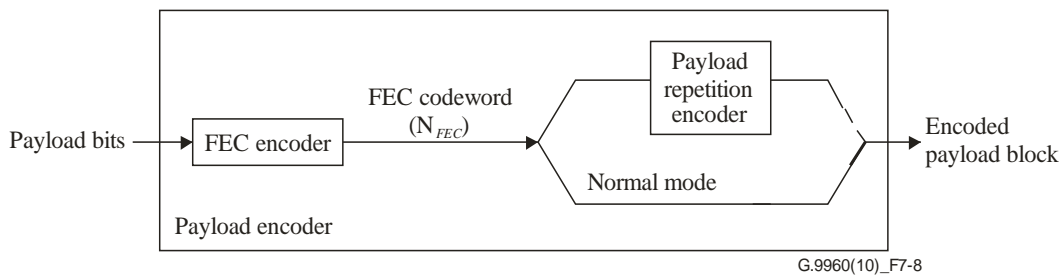

Figure 7-8 – Functional diagram of the payload encoder (set to normal mode)

The incoming PHY-frame payload shall be divided into sequential blocks of information bits, K bits per block. Each block of information bits shall be encoded by the FEC, as described in clause 7.1.3.2. The valid values of K , the coded block size N_{FEC} , and the coding rate R , are presented in Table 7-56. The bits of each information block shall be in the same order as they are in the payload; the payload bit to be transmitted first shall be the first in the corresponding information block.

In normal mode of operation, indicated by REP = 001 in the PHY-frame header, PRE is disabled. The FEC codewords shall be passed directly to the output of the payload encoder and concatenated into the encoded payload block; their order shall be the same as the order of corresponding information blocks at the input of the payload encoder.

In the case of RCM, each FEC codeword is further encoded by the PRE, as described in clause 7.1.3.3.1. The PRE-encoded FEC codewords are concatenated into the encoded payload block as defined in clause 7.1.3.3.1.

7.1.3.3.1 Payload repetition encoding

Payload repetition encoder (PRE) shall support the number of repetitions N_{REP} specified in Table 7-8. The used number of repetitions shall be advertised in the REP field in the PHY-frame header.

The PRE shall operate as follows. Each incoming FEC codeword shall be first copied N_{REP} times. Each copy shall be divided into S sections, numbered from 0 to $S-1$, with B bits in each section, as follows:

- Bits of the FEC codeword shall be mapped into sections in ascending sequential order; the bit of the FEC codeword to be transmitted first shall be the first bit (b_0) of Section 0.
- If after all bits of the FEC codeword are mapped, the last q bit positions of the last section remain empty, these positions shall be filled by the first q bits of Section 0 in ascending sequential order.

Mapping of an FEC codeword on to sections is shown in Figure 7-9.

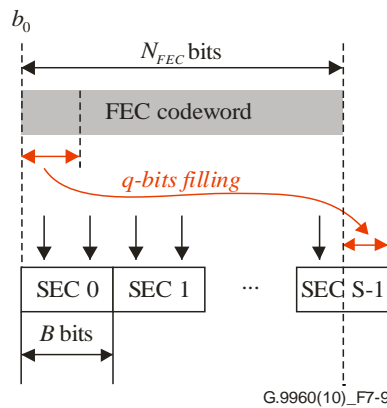

Figure 7-9 – Mapping of a FEC codeword on to sections

If $\text{floor}(k_P/N_{REP})$ is divisible by 4, the number of bits per section shall be set to $B = \text{floor}(k_P/N_{REP}) - 1$; otherwise, it shall be set to $B = \text{floor}(k_P/N_{REP})$, where k_P is the total number of bits that can be loaded on to the payload OFDM symbol according to the current BAT. The number of sections per FEC codeword is: $S = \text{ceiling}(N_{FEC}/B)$.

If the computed value of S is 1, H consecutive FEC codewords may be concatenated. The number of sections in this case shall be: $S = \text{ceil}(H \times N_{FEC}/B)$, where H is selected to provide $S > 1$ for the given values of N_{FEC} , N_{REP} and k_P . Concatenation of codewords may only be applied when an FEC information block size of 960 is used. The total size of the concatenated codewords shall not exceed the maximum FEC codeword size.

PRE parameters N_{REP} and H shall be selected such that $q < H \times N_{FEC}$.

If the number of FEC codewords in the payload is not a multiple of H , the necessary $z < H$ dummy FEC codewords shall be added. These dummy codewords shall be copies of the last FEC codeword of the same payload. The values of H (1, 2 and 4) and z (0 to $H-1$) are indicated in the FCF field of the PHY-frame header (see Table 7-9).

The PRE shall output sections sequentially, in groups of S sections. Each group carries a copy of the FEC codeword. The number of groups per each FEC codeword is N_{REP} . The order of bits in each section shall be the same as these bits appear in the incoming FEC codeword.

The format of the encoded payload block with PRE enabled is presented in Figure 7-10. The total number of sections in the encoded payload block is $N_{REP} \times S$.

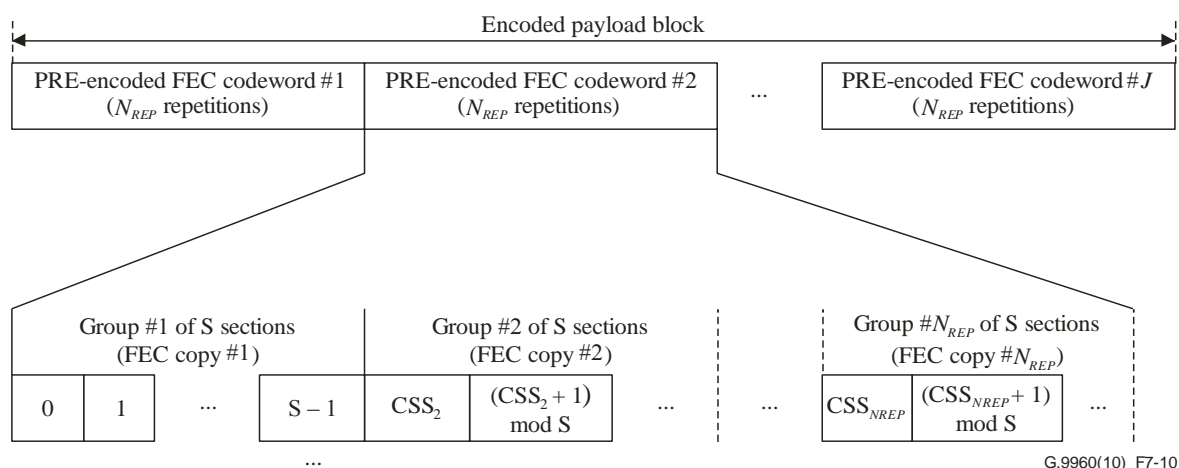

**Figure 7-10 – The format of the encoded payload block
(payload consists of J FEC codewords)**

The order of sections in the first group shall be ascending, from 0 to $S-1$; the order of sections in all subsequent groups shall be cyclically shifted. The shift is defined by the cyclic section shift (CSS) vector $\{0 \text{ CSS}_2 \text{ CSS}_3 \dots \text{CSS}_{N_{REP}}\}$ with a length of N_{REP} , where CSS_L is the sequential number of the section to be transmitted first in the L th group of sections. The value of CSS shall be computed using the following rule:

For $N_{REP} = 2$:

if $(S \bmod 2) = 0$ $\text{CSS} := \{0,1\}$;
else $\text{CSS} := \{0,0\}$;

For $N_{REP} = 4$:

if $(S \bmod 4) = 0$ $\text{CSS} := \{0,1,2,3\}$;
else if $(S \bmod 2) = 0$ $\text{CSS} := \{0,0,1,1\}$;
else $\text{CSS} := \{0,0,0,0\}$;

For $N_{REP} = 3$:

if $(S \bmod 3) = 0$ $\text{CSS} := \{0,1,2\}$;
else $\text{CSS} := \{0,0,0\}$;

For $N_{REP} = 6$:

if $(S \bmod 6) = 0$ $\text{CSS} := \{0,1,2,3,4,5\}$;
else if $(S \bmod 3) = 0$ $\text{CSS} := \{0,0,1,1,2,2\}$;
else if $(S \bmod 2) = 0$ $\text{CSS} := \{0,0,0,1,1,1\}$;
else $\text{CSS} := \{0,0,0,0,0,0\}$;

For $N_{REP} = 8$:

if $(S \bmod 8) = 0$ $\text{CSS} := \{0,1,2,3,4,5,6,7\}$;
else if $(S \bmod 4) = 0$ $\text{CSS} := \{0,0,1,1,2,2,3,3\}$;
else if $(S \bmod 2) = 0$ $\text{CSS} := \{0,0,0,0,1,1,1,1\}$;

else $CSS := \{0,0,0,0,0,0,0,0\};$

NOTE – As an example, with $CSS = 3_L$ for a group of $S = 4$ sections, these sections will be transmitted in the following order: 3, 0, 1, 2. The first group of sections, for comparison, is transmitted: 0, 1, 2, 3.

7.1.3.4 Header encoder

The functional model of the header encoder is presented in Figure 7-11. It contains an FEC encoder and a header repetition encoder (HRE).

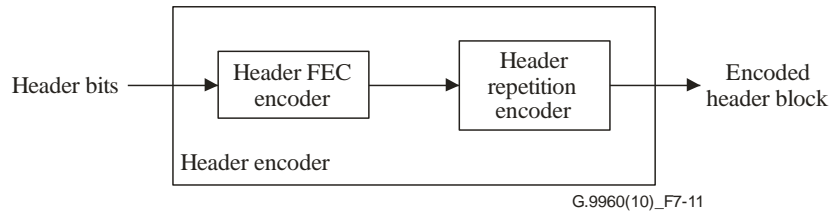

Figure 7-11 – Functional diagram of the header encoder

The bits of the PHY-frame header shall be input into the header FEC encoder in their original order and encoded as described in clause 7.1.3.2. The size of the FEC codeword and the coding rate of the header FEC encoder are described in Table 7-56.

The FEC codeword enters the HRE. The HRE shall operate as follows:

- The FEC codeword shall be first copied M times, where $M = \text{ceiling}(k_H/N_{FEC})$, k_H is the number of bits to be loaded on to the OFDM symbol carrying the header.
- The first encoded header block shall be formed by concatenation of M copies of the header FEC encoder output. The bits (b_i) within each codeword shall be cyclically shifted by 2 bits as follows:
 - The 1st FEC codeword copy shall be formed as $\{b_0, b_1, \dots, b_{NFEC-2}, b_{NFEC-1}\}$.
 - The 2nd FEC codeword copy shall be formed as $\{b_2, b_3, \dots, b_{NFEC-1}, b_0, b_1\}$.
 - The 3rd FEC codeword copy shall be formed as $\{b_4, b_5, \dots, b_{NFEC-1}, b_0, b_1, b_2, b_3\}$.
 - ...
 - The M th FEC codeword copy, where $M > 3$, shall be formed as $\{b_{(2 \times M - 2)}, b_{(2 \times M - 1)}, \dots, b_{NFEC-1}, b_0, b_1, \dots, b_{(2 \times M - 4)}, b_{(2 \times M - 3)}\}$.
- The second encoded header block shall be formed by cyclic shifting of each copy by $N_{FEC}/2$ bits and concatenation of M copies of the shifted FEC codeword. The bits (b_i) within each codeword shall be cyclically shifted by 2 bits as follows:
 - The 1st FEC codeword copy shall be formed as $\{b_{NFEC/2}, b_{NFEC/2+1}, \dots, b_{NFEC-2}, b_{NFEC-1}, b_0, b_1, \dots, b_{NFEC/2-2}, b_{NFEC/2-1}\}$.
 - The 2nd FEC codeword copy shall be formed as $\{b_{NFEC/2+2}, b_{NFEC/2+3}, \dots, b_{NFEC-2}, b_{NFEC-1}, b_0, b_1, \dots, b_{NFEC/2}, b_{NFEC/2+1}\}$.
 - The 3rd FEC codeword copy shall be formed as $\{b_{NFEC/2+4}, b_{NFEC/2+5}, \dots, b_{NFEC-2}, b_{NFEC-1}, b_0, b_1, \dots, b_{NFEC/2+2}, b_{NFEC/2+3}\}$.
 - ...
 - The M th FEC codeword copy, where $M > 3$, shall be formed as $\{b_{NFEC/2+(2 \times M - 2)}, b_{NFEC/2+(2 \times M - 1)}, \dots, b_{NFEC-1}, b_0, b_1, \dots, b_{NFEC/2+(2 \times M - 4)}, b_{NFEC/2+(2 \times M - 3)}\}$.

NOTE – Since the coding rate used for header encoding is 1/2, the number of bits in the FEC codeword is always even, and the number of bits in the encoded header block is even.

7.1.3.5 Segmentation into symbol frames

The encoded payload block from the output of payload encoder and the encoded header block from the output of the header encoder shall be segmented into symbol frames. The maximum number of bits in the symbol frame shall not exceed the values of k_P for payload symbol frames and k_H for header symbol frames. Payload and header symbol frames shall be passed to the PMD, as described in Figure 7-5.

7.1.3.5.1 Payload segmentation

The encoded payload block shall be segmented into one or more symbol frames.

In normal mode, the first symbol frame shall contain the first k_P bits of the encoded payload block, the second frame shall contain the second k_P bits of the encoded payload block and so on, until the last symbol frame. If the number of bits in the last symbol frame is less than k_P , the unloaded supported subcarriers of the OFDM symbol for the last symbol frame shall be modulated by a pseudorandom sequence of bits, as described in clause 7.1.4.2.6. Payload segmentation is illustrated in Figure 7-12.

In RCM, the first symbol frame shall contain the first N_{REP} sections of the encoded payload block, the second frame shall contain the second N_{REP} sections of the encoded payload block, and so on, until the last symbol frame. If the number of bits in N_{REP} sections is less than k_P , the unloaded supported subcarriers of the corresponding OFDM symbols shall be modulated by a pseudorandom sequence of bits, as described in clause 7.1.4.2.6.

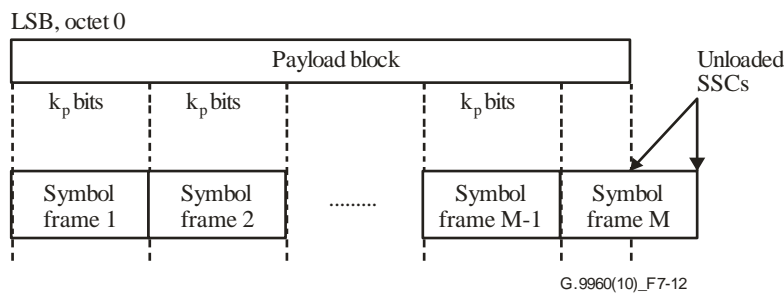

Figure 7-12 – Payload segmentation

7.1.3.5.2 Header segmentation

The encoded header block shall be segmented into D symbol frames (valid values of D are 1 and 2). Selection of the value of D is determined by the domain master (see clause 8.6.7 of [ITU-T G.9961]), indicated in the PHY-frame header (see clause 7.1.2.3.1.8) and in the TXOP descriptor (see Table 8-65 in [ITU-T G.9961]).

The first k_H bits of the first encoded header block shall be mapped into the first symbol frame of the header, so that b_0 is transmitted first.

If $D = 2$, the first k_H bits of the second encoded header block shall be mapped into the second symbol frame of the header, so that $b_{NFEC/2}$ is transmitted first.

The rest of the bits of the first and the second encoded header blocks shall be discarded.

Header segmentation is illustrated in Figure 7-13.

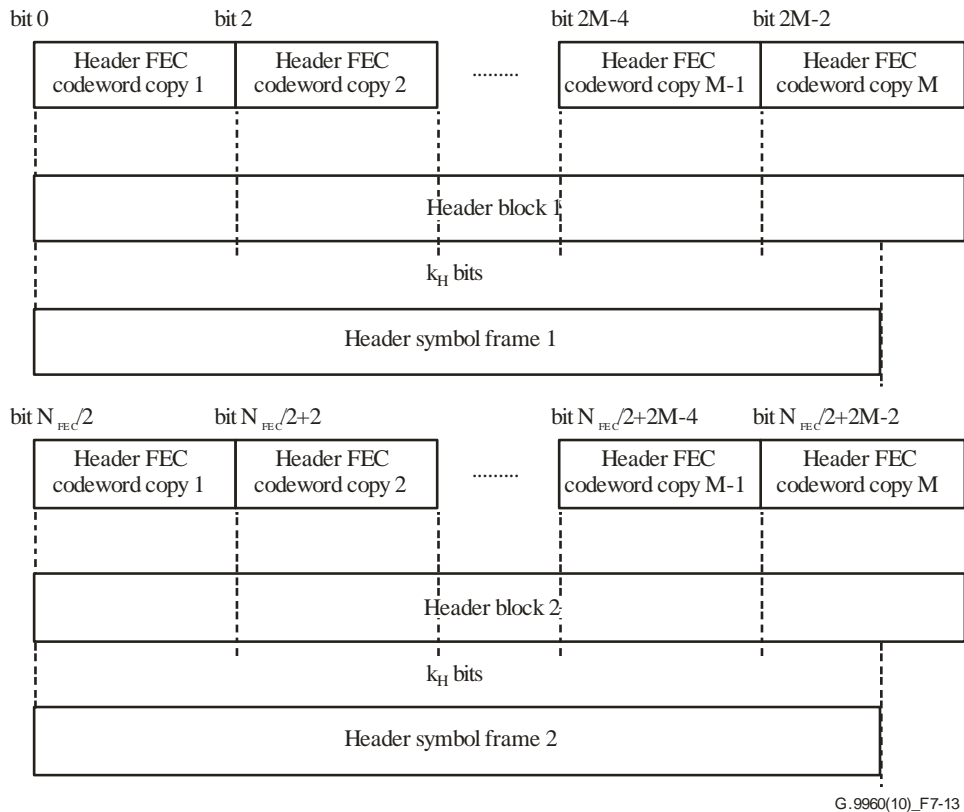

G.9960(10)_F7-13

Figure 7-13 – Header segmentation

7.1.3.6 PROBE frame

The PROBE frame is intended for the channel estimation procedure. The header of the PROBE frame shall be as defined in clause 7.1.2.3 and its subclauses. The payload of the PROBE frame contains a number of probe symbols, i.e., symbol frames with no data, which can be of two types, as specified in clause 7.1.4.2.5.3:

- Silent probe symbols, for which all subcarriers are considered MSCs (masked subcarriers).
- Channel estimation probe symbols, for which all supported subcarriers (SSCs) are considered inactive subcarriers (ISCs) and are modulated by a pseudorandom sequence.

The number of probe symbols in each frame shall be indicated via the PRBSYM field in clause 7.1.2.3.2.7.1.3.

Two probe frame types are specified and identified by the PRBTYPE field specified in clause 7.1.2.3.2.7.1.2 (Table 7-40):

- The "Silent PROBE frame" (PRBTYPE 0000₂). The payload of this frame type is composed of silent symbols.
- The "Channel estimation PROBE frame" (PRBTYPE 0001₂). The payload of this frame type is composed of channel estimation probe symbols.

7.1.4 Physical medium dependent (PMD) sublayer

The functional model of the PMD is presented in Figure 7-14. In the transmit direction, the tone mapper divides the incoming symbol frames of the header and payload into groups of bits and associates each group of bits with a specific subcarrier on to which this group shall be loaded, as specified in clause 7.1.4.2. The constellation encoder converts each incoming group of bits into a complex number that represents the constellation point for this subcarrier. The constellation mapping

process is described in clause 7.1.4.3.1. The unloaded supported subcarriers are modulated by a pseudorandom bit sequence generated as described in clause 7.1.4.2.6.

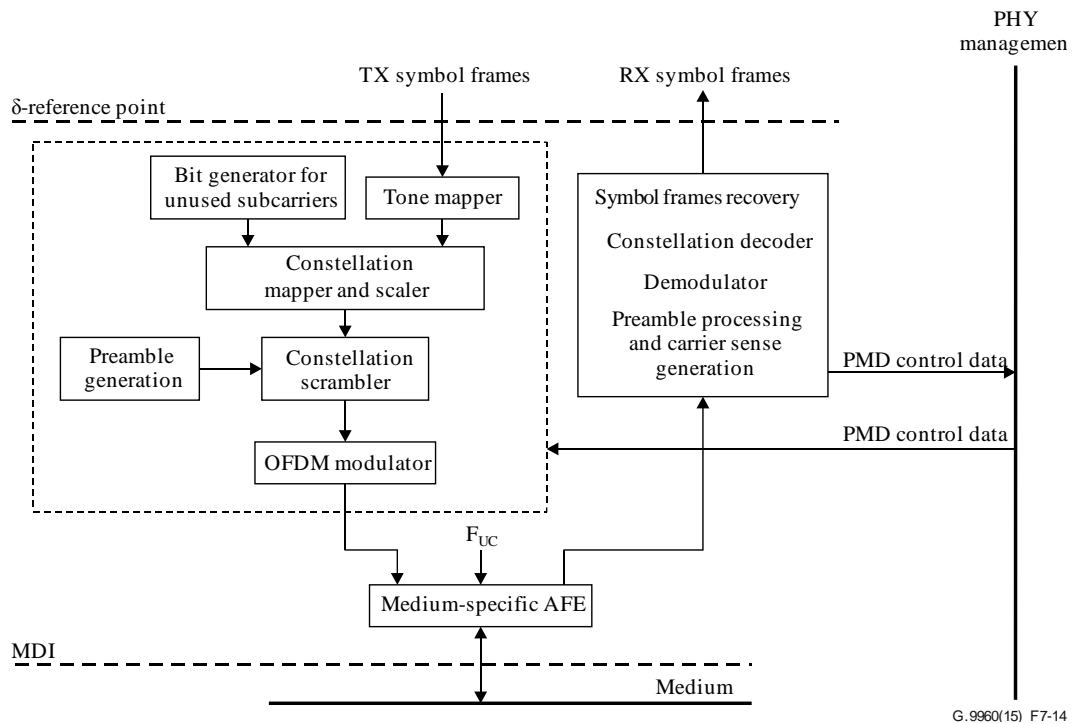

Figure 7-14 – Functional model of the PMD

The OFDM modulator (clause 7.1.4.4) converts the stream of the N complex numbers at its input into the stream of N complex valued time-domain samples. After adding the preamble, the transmit signal is up-shifted by F_{US} . For RF applications, the transmit signal is further up-converted by F_{UC} to fit the required spectrum of the transmit signal. The real part of the resultant signal is transmitted on to the medium. Parameters of the preamble (clause 7.1.4.5) are determined by the PHY management and depend on the type of the transmitted PHY frame.

Frames are output on to the medium with inter-frame gaps.

In the receive direction, the frames incoming from the medium are demodulated and decoded. The recovered symbol frames are transferred to the PMA via the δ -reference point. The preamble is processed and preamble data are passed to the PHY management entity.

7.1.4.1 Subcarrier spacing and indexing

The subcarrier spacing F_{SC} is the frequency spacing between any two adjacent subcarriers. Valid values of subcarrier spacing are presented in Table 7-67.

The physical index i corresponds to the order of subcarriers in ascending frequency. The subcarrier with physical index i shall be centred at frequency $f = F_{UC} + F_{US} - (N/2 - i) \times F_{SC}$. The index i goes from 0 to $N - 1$.

The logical index j indicates the order in which data is loaded on subcarriers. The index j goes from 0 to $N - 1$.

Two indexing rules that relate the physical index and the logical index are defined:

Rule #1: $i=j$, i.e., the subcarriers are loaded in order of ascending frequency.

The subcarrier with logical index j shall be centred at frequency $f = F_{UC} + F_{US} - (N/2 - j) \times F_{SC}$.

Rule #2: $i = N/2 + j/2$ for even values of j , $i = N/2 - (j + 1)/2$ for odd values of j .

The subcarriers with even logical indices from $j = 0$ to $j = N - 2$ shall be centred at frequencies $f = F_{UC} + F_{US} + (j/2) \times F_{SC}$ while those with odd logical indices from $j = 1$ to $j = N - 1$ shall be centred at frequencies $f = F_{UC} + F_{US} - ((j + 1)/2) \times F_{SC}$.

Logical indexing rules shall be applied in accordance with the domain type and the bandplan, as specified in Tables 7-67, 7-73, and 7-80. Throughout the Recommendation, the term "subcarrier index" refers to the physical index, unless otherwise noted.

Not all subcarriers may always be used for data transmission; some of them have to be switched off in special circumstances. Others may be only used with reduced power. The latter functions are performed by subcarrier masking and gain scaling (see clauses 5.1 and 5.2 of [\[ITU-T G.9964\]](#)).

NOTE – The particular subcarriers used for data transmission between two particular nodes depend on channel characteristics, such as loop attenuation and noise, and on the specific spectrum-use requirements, such as notching of amateur radio bands; some subcarriers may be subject to PSD reduction, e.g., at high and low frequencies to share the medium with other services.

7.1.4.2 Tone mapper

The tone mapper divides the incoming symbol frames of the header and payload into groups of bits (according to the BATs and subcarrier grouping being used) and associates each group of bits with specific subcarriers on to which these groups shall be loaded. This information along with subcarrier-specific gain scaling values as described in clause 7.1.4.3.2.3 are passed to the constellation encoder.

7.1.4.2.1 Summary of subcarrier types

For the purpose of tone mapping, the following types of subcarriers are defined.

- 1) Masked subcarriers (MSCs) are those on which transmission is not allowed, i.e., the gain on this subcarrier shall be set to zero. Two types of MSC are defined:
 - Permanently masked subcarriers (PMSCs) – those that are never allowed for transmission. The list of PMSC forms a PMSC mask, which depends on the type of medium and is defined in clause 7.2. Data bits are never mapped on PMSC.
 - Regionally masked subcarriers (RMSCs) – those that are not allowed for data transmission in some regions, while may be allowed in other regions. The list of RMSC forms a RMSC mask, which depends on the type of media and on the region/application. The RMSC set consists of the subcarriers corresponding to subcarrier masks defined in SM descriptor and masked amateur radio bands defined in amateur radio band descriptor (see clause 8.8.5.5 of [\[ITU-T G.9961\]](#)). The number of RMSCs, $\#RMSC = \#MSC - \#PMSC$.
- 2) Supported subcarriers (SSCs) are those on which transmission is allowed under restrictions of the relevant PSD mask. The number of SSCs, $\#SSC = N - \#MSC$. The following types of SSC are defined:
 - Active subcarriers (ASCs) – those that have loaded bits ($b \geq 1$) for data transmission. ASCs are subject to constellation point mapping, constellation scaling and constellation scrambling as described in clause 7.1.4.3. Data bits shall be mapped on ASCs as described in clause 7.1.4.2.2.
 - Inactive subcarriers (ISCs) – those that do not have any data bits loaded (e.g., because SNR is low). The number of ISCs, $\#ISC = \#SSC - \#ASC$. ISCs can be used for measurement purposes or other auxiliary purposes. ISCs are subject to transmit power shaping. The signals transmitted on ISC are defined in clause 7.1.4.2.6.

7.1.4.2.2 Bit allocation tables (BATs)

Tone mapping is defined by a bit allocation table (BAT) that associates subcarrier indices with the number of bits to be loaded on the subcarrier.

The BATs used by the node in the particular PHY frame shall be indicated to the receiving node(s) in the BAT_ID field of the MSG PHY-frame type specific fields of the PHY-frame header, as described in clause 7.1.2.3.2.2.8. Up to 32 BATs with BAT_ID values in the range from 0 to 31 can be defined. One or more BAT_IDs can be assigned for each destination (per unicast or multicast DID, see clause 7.1.2.3.1.5). The assignment of BAT_IDs shall be as shown in Table 7-57.

Table 7-57 – Assignment of BAT_ID

BAT_ID	Type of BAT	Reference
0	Predefined, Type 0	Clause 7.1.4.2.2.1
1	Predefined, Type 1	
2	Predefined, Type 2	
3	Predefined, Type 3	
4 to 7	Reserved by ITU-T for predefined BATs	
8 to 31	Reserved by ITU-T for runtime BATs	Clause 7.1.4.2.2.2

Every node shall support at least predefined BATs of Type 0, Type 1, Type 2 and Type 3. Support of other BATs is profile-dependent.

7.1.4.2.2.1 Predefined BATs

The following predefined BATs are defined:

- 1) Predefined BAT Type 0: uniform 1-bit loading on all subcarriers except the PMSC set.
- 2) Predefined BAT Type 1: uniform 2-bit loading on all subcarriers except the PMSC set.
- 3) Predefined BAT Type 2: uniform 2-bit loading on all subcarriers except the PMSC and the RMSC sets (a complete SSC set).
- 4) Predefined BAT Type 3: uniform 1-bit loading on all subcarriers except the PMSC set and the RMSC sets (a complete SSC set).

NOTE – Predefined BAT Type 0, Type 1, Type 2, and Type 3 may be used when channel characteristics are unknown (i.e., no knowledge is available on whether particular subcarriers could be loaded with bits or not).

7.1.4.2.2.2 Runtime BATs

A runtime BAT associates indices of SSCs with the number of bits to be loaded on each subcarrier. The subset of indices in the BAT with the number of loaded bits $b > 0$ identifies the ASC. Runtime BAT can be defined by the receiving node (receiver-defined BAT) or selected by the transmitting node (transmitter-determined BAT) for a specific unicast or multicast channel. Runtime BATs shall be communicated from the node that generates the BAT to the peer (e.g., a node sourcing multicast transmission to several other nodes will communicate the BAT to all receiving nodes prior to sending data) (see clauses 8.11 and 8.16 of [\[ITU-T G.9961\]](#)).

The number of bits loaded on any subcarrier shall not exceed the maximum number of bits allowed (see clause 7.1.4.3). The number of bits shall also meet the bit loading capabilities of the communicating nodes, as advertised by them prior to communication.

7.1.4.2.3 Transmitter-determined and receiver-determined mapping

Two types of tone mapping are defined: transmitter-determined and receiver-determined. With transmitter-determined mapping, the BAT is defined by the transmitter and shall be either a predefined BAT or it shall be communicated to all destination nodes prior to transmission using the channel estimation protocol for unicast transmission (see clause 8.11 of [\[ITU-T G.9961\]](#)) and in addition using the multicast binding protocol for multicast transmission (see clause 8.16 of

[ITU-T G.9961]). With receiver-determined mapping, the BAT is defined by the receiver of the destination node and communicated to the transmitter using the channel estimation protocol.

For unicast transmission, the node shall use either one of the predefined BATs (transmitter-determined) or a BAT defined by the receiver of the destination node for the PHY frame. For multicast transmission both predefined BATs (transmitter-determined) and runtime BATs can be used. If a runtime BAT is used, it shall be defined by the node sourcing the multicast (transmitter-determined); this node shall generate the BAT and communicate it to all multicast destinations (see clauses 8.11 and 8.16 of [ITU-T G.9961]).

Both transmitter-determined and receiver-determined BATs may be defined that are valid for only specific portions of the MAC cycle. The portion of the MAC cycle for which a specific BAT is valid for is called a BAT region. In the case of receiver-determined BATs, the applicable BAT region(s) including the starting point and ending point of each of the BAT regions with respect to the MAC cycle are conveyed to the transmitter as a part of the channel estimation protocol.

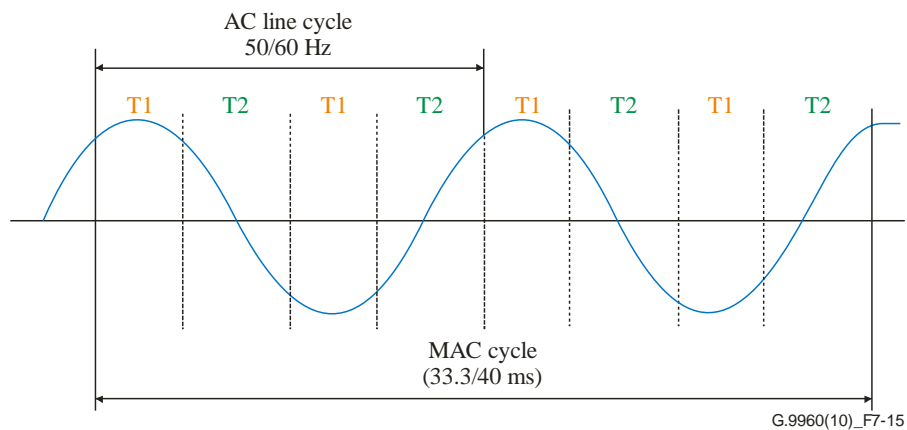

Figure 7-15 – An example of BAT regions in a MAC cycle for power line

Figure 7-15 illustrates multiple BAT regions for a power line. In this example, the BAT regions are periodic about half AC line cycle and it has two BATs. BAT T1 is used around the peaks of the AC line cycle and BAT T2 is used around the zero crossings of the AC line cycle. The receiver shall inform the transmitter about the starting point and the ending point of each of the BAT regions with respect to the MAC cycle as a part of the channel estimation protocol.

A node shall support both transmitter-determined and receiver-determined types of mapping, with the minimum number of simultaneously supported BATs depending on the profile.

7.1.4.2.4 BAT with subcarrier grouping

A node shall be capable of defining any runtime BAT using a subcarrier grouping of $G = 1$ (no grouping), 2, 4, 8, and 16 subcarriers with subsequent frequencies. The default value of $G = 1$. If grouping is used ($G > 1$), all subcarriers of the same group shall use the same bit loading. The first group shall include G subcarriers in ascending order of subcarrier indices defined in clause 7.1.4.1. If a group includes subcarriers that are masked (i.e., MSC) or extends beyond the applicable subcarrier set, the node shall apply the bit loading assigned for this group only to the applicable subcarrier set (i.e., SSC).

The group index G shall be indicated when the BAT is communicated (see clause 8.11 of [ITU-T G.9961]). Additional methods for BAT compression are for further study.

7.1.4.2.5 Special mappings

7.1.4.2.5.1 Tone mapping for PHY-frame header

The PHY-frame header shall use a uniform loading of two bits per subcarrier on all subcarriers except the PMSC set.

7.1.4.2.5.2 Tone mapping for RCM

Payload transmission in robust communication mode (RCM) shall use predefined BAT types with uniform two bits per subcarrier loading.

7.1.4.2.5.3 Tone mapping for the probe symbols

Two types of probe symbols are specified: silent symbols and channel estimation probe symbols. Tone mapping shall apply to these symbols according to the following:

- For silent symbols, all subcarriers shall be considered as MSCs (masked subcarriers).
- Channel estimation probe symbols shall be modulated using a uniform loading of two bits per subcarrier on all SSC sets. For these probe symbols, the ISC set shall be equal to the SSC set. All ISC subcarriers shall be modulated by a pseudorandom sequence of bits, as described in clause 7.1.4.2.6.

7.1.4.2.5.4 Tone mapping for ACE symbols

The ACE symbol shall be modulated using a uniform loading of two bits per subcarrier on all SSC sets. For the ACE, $ISC = SSC$. All ISC subcarriers shall be modulated by a pseudorandom sequence of bits, as described in clause 7.1.4.2.6.

7.1.4.2.6 Modulation of unloaded supported subcarriers

Supported subcarriers (SSCs) that are not loaded with encoded payload bits or that are partially loaded with encoded payload bits – that is, ISC and unloaded or partially loaded ASC (herein referred to as unloaded SSC) – shall be loaded with a pseudorandom sequence defined by the linear feedback shift register (LFSR) generator with the polynomial $p(x) = x^{23} + x^{18} + 1$ shown in Figure 7-16. The LFSR generator shall be initialized at the beginning of each OFDM symbol with a DM-generated seed received during registration of the node into the domain through the UnloadedSubcarrierInitialSeed field of the additional domain information auxiliary information field (see clause 8.8.5.15). The i -th payload symbol shall use the seed S_k where k is equal to $(i-1, \text{modulo } 64) + 1$, where $i = 1, 2, 3, 4, \dots$. S_k is generated by advancing the LFSR by $8192*(k-1)$ from the original DM-generated seed. An example of LFSR seeds for an initial seed of $7FFFFFFF_{16}$ is provided in Table 7-58.

NOTE – Seeds S_1 to S_{64} are used to initialize the LFSR for payload symbols 1-64, 65-128 and so on. The LSB of the seed S_k corresponds to c_1 .

The DM-generated seed shall be chosen among the pool of allowed seeds described in Table 7-57.1, depending on the value of the DOD of the domain.

Table 7-57.1 – Pool of allowed DM-generated seeds for unloaded supported subcarriers LFSR generator

DOD	Allowed seeds
0	7FFFFFF ₁₆ ; 003FE0 ₁₆ ; 7FC060 ₁₆ ; 7803F9 ₁₆ ; 0FF813 ₁₆ ; 7EFE80 ₁₆ ; 01FCFC ₁₆ ; 40202F ₁₆ ; 038638 ₁₆
1	7FFFFFF ₁₆ ; 7DC2E0 ₁₆ ; 70874D ₁₆ ; 401FB7 ₁₆ ; 61F327 ₁₆ ; 0F78B3 ₁₆ ; 3FDFD7 ₁₆ ; 0DC513 ₁₆ ; 1E73E7 ₁₆
2	7FFFFFF ₁₆ ; 1EB138 ₁₆ ; 731F9B ₁₆ ; 057B41 ₁₆ ; 4DE53C ₁₆ ; 7099A3 ₁₆ ; 0080A6 ₁₆ ; 07BC5A ₁₆ ; 0399C8 ₁₆
3	7FFFFFF ₁₆ ; 3027C4 ₁₆ ; 1F8F1B ₁₆ ; 30A762 ₁₆ ; 1D8A1F ₁₆ ; 6FB79B ₁₆ ; 6E3675 ₁₆ ; 78B9A1 ₁₆ ; 65F92E ₁₆
4	7FFFFFF ₁₆ ; 5EED10 ₁₆ ; 7F3F09 ₁₆ ; 16E6B5 ₁₆ ; 5FD0FF ₁₆ ; 1EB13C ₁₆ ; 6B8DD5 ₁₆ ; 7795D2 ₁₆ ; 3D222E ₁₆
5	7FFFFFF ₁₆ ; 0174B0 ₁₆ ; 79903D ₁₆ ; 604F7B ₁₆ ; 38638D ₁₆ ; 698A2D ₁₆ ; 7CE688 ₁₆ ; 50281F ₁₆ ; 48E4C4 ₁₆
6	7FFFFFF ₁₆ ; 7ABE59 ₁₆ ; 785321 ₁₆ ; 26D2B1 ₁₆ ; 0207F8 ₁₆ ; 0B6CAA ₁₆ ; 306764 ₁₆ ; 096B52 ₁₆ ; 12757B ₁₆
7	7FFFFFF ₁₆ ; 734122 ₁₆ ; 1D29EE ₁₆ ; 4D67BC ₁₆ ; 073961 ₁₆ ; 763502 ₁₆ ; 7C58CE ₁₆ ; 7B4816 ₁₆ ; 5E6F90 ₁₆
8	7FFFFFF ₁₆ ; 0AFC72 ₁₆ ; 198299 ₁₆ ; 5AABBE ₁₆ ; 1E8EDC ₁₆ ; 618E01 ₁₆ ; 6E289F ₁₆ ; 5B22F8 ₁₆ ; 416B07 ₁₆
9	7FFFFFF ₁₆ ; 771574 ₁₆ ; 779791 ₁₆ ; 5D54B7 ₁₆ ; 479BCE ₁₆ ; 1EBBF8 ₁₆ ; 09EBF4 ₁₆ ; 6926AD ₁₆ ; 3B5461 ₁₆
10	7FFFFFF ₁₆ ; 06764F ₁₆ ; 2EC96F ₁₆ ; 3BFA45 ₁₆ ; 316B09 ₁₆ ; 6876D1 ₁₆ ; 7FEF7B ₁₆ ; 0ABF31 ₁₆ ; 600E3B ₁₆
11	7FFFFFF ₁₆ ; 5295BF ₁₆ ; 3C064C ₁₆ ; 48FB34 ₁₆ ; 272E4D ₁₆ ; 32203C ₁₆ ; 478CF6 ₁₆ ; 7330FC ₁₆ ; 098416 ₁₆
12	7FFFFFF ₁₆ ; 40E0C4 ₁₆ ; 6A49F1 ₁₆ ; 620823 ₁₆ ; 44153E ₁₆ ; 3BD438 ₁₆ ; 0878EA ₁₆ ; 57EB86 ₁₆ ; 3DA277 ₁₆
13	7FFFFFF ₁₆ ; 12CF23 ₁₆ ; 730171 ₁₆ ; 164544 ₁₆ ; 1AB7C9 ₁₆ ; 74191A ₁₆ ; 33A4AA ₁₆ ; 68843A ₁₆ ; 3CC639 ₁₆
14	7FFFFFF ₁₆ ; 1A6FB3 ₁₆ ; 068AF6 ₁₆ ; 79DC09 ₁₆ ; 2E8D44 ₁₆ ; 0733A1 ₁₆ ; 24E0D0 ₁₆ ; 3F4001 ₁₆ ; 1D56D2 ₁₆
15	7FFFFFF ₁₆ ; 68BC83 ₁₆ ; 612F91 ₁₆ ; 6E76A9 ₁₆ ; 51F4FC ₁₆ ; 2B2C4D ₁₆ ; 2C2B62 ₁₆ ; 05A54A ₁₆ ; 28476E ₁₆

The first allowed value is common for all DODs and is called the default value for the unloaded supported subcarriers LFSR generator.

The LFSR shall be advanced by two bits for each subcarrier (for both SSC and MSC) of each symbol of the payload. Two LFSR bits corresponding to the subcarrier index 0 are (c_1, c_2) of the initialization seed. Two LFSR bits corresponding to the subcarrier index 1 are (c_1, c_2) after two shifts, and so on. For modulation of unloaded subcarriers, ACE symbols shall be treated in the same manner as payload symbols.

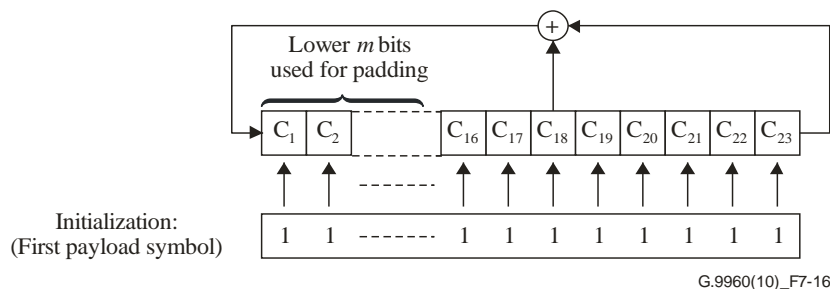

Figure 7-16 – LFSR for modulation of unloaded and partially loaded subcarriers

Table 7-58 – Example LFSR seeds for an initial DM-generated seed of 7FFFFFF₁₆

Seed index k	Seed (S_k)
1	7FFFFFF ₁₆
2	26B489 ₁₆
3	278A91 ₁₆

Table 7-58 – Example LFSR seeds for an initial DM-generated seed of 7FFFFFF₁₆

Seed index k	Seed (S_k)
4	15F4ED ₁₆
5	5B4CB1 ₁₆
6	2F021F ₁₆
7	7A64C1 ₁₆
8	414CD7 ₁₆
9	649D5E ₁₆
10	134826 ₁₆
11	2A3DFC ₁₆
12	2B9570 ₁₆
13	3C6777 ₁₆
14	757986 ₁₆
15	103962 ₁₆
16	0DB87B ₁₆
17	076287 ₁₆
18	3E1A31 ₁₆
19	05DE6D ₁₆
20	5C5B4E ₁₆
21	596413 ₁₆
22	0613D9 ₁₆
23	19504A ₁₆
24	50FDE0 ₁₆
25	5CD048 ₁₆
26	66C646 ₁₆
27	7169B3 ₁₆
28	480497 ₁₆
29	053FE3 ₁₆
30	51F1B1 ₁₆
31	7D2BA0 ₁₆
32	11E4D8 ₁₆
33	037144 ₁₆
34	278587 ₁₆
35	2CF7F7 ₁₆
36	027D46 ₁₆
37	70A7EB ₁₆
38	4C622C ₁₆
39	54DC68 ₁₆
40	01715E ₁₆
41	274A7B ₁₆
42	55238D ₁₆

Table 7-58 – Example LFSR seeds for an initial DM-generated seed of 7FFFFFF₁₆

Seed index k	Seed (S_k)
43	008B06 ₁₆
44	3FA255 ₁₆
45	777A6A ₁₆
46	5154DD ₁₆
47	55C203 ₁₆
48	0D21F9 ₁₆
49	1BEDE6 ₁₆
50	608D6B ₁₆
51	4B75D3 ₁₆
52	22BA64 ₁₆
53	7D0646 ₁₆
54	7F56E6 ₁₆
55	614333 ₁₆
56	4F1368 ₁₆
57	7359EF ₁₆
58	2D86A9 ₁₆
59	25373D ₁₆
60	258466 ₁₆
61	4CE92A ₁₆
62	6B7E3D ₁₆
63	760B34 ₁₆
64	761EA6 ₁₆

The modulation of subcarriers that are not loaded with encoded payload bits shall be as follows:

- 1) Starting at the beginning of the first payload OFDM symbol, each subcarrier from the ISC set shall be modulated with the two bits which are the LSBs of the LFSR, c_1 , and c_2 using the 2-bit constellation mapping defined in clause 7.1.4.3.1.1 (c_1 is transmitted first).
- 2) In every OFDM symbol of payload, if the number of bits in the symbol frame does not fill the entire symbol, the bits from the LFSR shall be used to fill the remainder of the symbol frame, by taking the sequential groups of m LSBs of the LFSR and mapping them on to the remaining subcarriers so that LSB of LFSR is transmitted first and in the order defined by the current BAT, where m is the number of bits allocated for that subcarrier by the BAT. For the first padded subcarrier, if n bits of the m loaded bits are data bits ($n < m$), these n data bits shall be loaded as the LSBs of the group of bits mapped on the constellation point, and the $m - n$ bits of the LFSR shall be used as the MSBs of the group of bits mapped on the constellation point starting from LSB of LFSR.
- 3) In the case of a PROBE frame, starting at the beginning of the first payload OFDM symbol, each subcarrier from the ISC set shall be modulated with the two bits which are the LSBs of the LFSR, c_1 and c_2 , using 2-bit constellation mapping defined in clause 7.1.4.3.1.1 (c_1 is transmitted first).

The bits from LFSR are loaded on subcarriers in the order of logical indices (i.e., in the same way as data is loaded over payload symbols), according to subcarrier indexing defined in clause 7.1.4.1.

Modulation of unloaded subcarriers shall start from the unloaded SSC with the lowest logical index of the first payload symbol, continue in ascending order of logical indices until the unloaded SSC with the highest logical index of the first payload symbol, continue with the unloaded SSC with the lowest logical index of the second payload symbol, continue in ascending order of logical indices until the unloaded SSC with the highest logical index of the second payload symbol, and continue until the unloaded SSC with the highest logical index of the last payload symbol.

The ASCs from the SSC set are loaded according to the corresponding BAT as defined in clause 7.1.4.2.2.

7.1.4.3 Constellation encoder

7.1.4.3.1 Constellation mapping

Constellation mapping associates every group of bits loaded on to a subcarrier, with the values of I (in-phase component) and Q (quadrature-phase component) of a constellation diagram. Each incoming group of b bits $\{d_{b-1}, d_{b-2}, \dots, d_0\}$ shall be associated with a specific value of I and Q computed as described in this clause.

Each group of bits $\{d_{b-1}, d_{b-2}, \dots, d_0\}$ shall be mapped on to the constellation mapper with the LSB bit, d_0 , first.

7.1.4.3.1.1 Constellations for even number of bits

If the number of bits, b , loaded on to the subcarrier is even (2, 4, 6, 8, 10, 12), square-shaped constellations with mappings described in this clause shall be used. Support of all the specified even order constellations (2, 4, 6, 8, 10 and 12) shall be mandatory at both the transmitter and the receiver. With square-shaped constellations, 2^b constellation points are set as a square, and 2^{b-2} points reside in each quadrant with odd values (positive or negative) of I and Q .

Constellation and mapping for $b = 2$ shall be as presented in Figure 7-17 and described in Table 7-59.

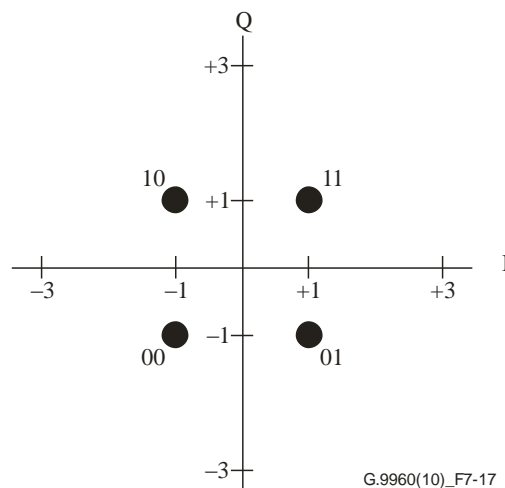

Figure 7-17 – Constellation and mapping for $b = 2$

Table 7-59 – Mapping for $b = 2$ (QPSK)

Bit d_0	I		Bit d_1	Q
0	-1		0	-1
1	1		1	1

Constellation mapping for $b = 4$ shall be as described in Table 7-60. The first quadrant of the mapping is presented in Figure 7-18.

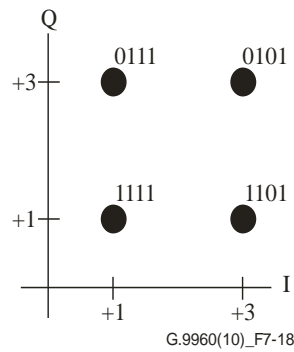

Figure 7-18 – Constellation and mapping for $b = 4$ (first quadrant)

Table 7-60 – Mapping for $b = 4$

Bits [d_1d_0]	I	Bit [d_3d_2]	Q
00	-3	00	-3
10	-1	10	-1
11	1	11	1
01	3	01	3

Constellation mappings for even values of $b \geq 4$ shall be derived by the following steps:

- 1) Divide the incoming group of b bits into two equal subgroups, so that $b/2$ LSBs form the first subgroup (I -group) and $b/2$ MSBs form the second subgroup (Q -group); both subgroups are incoming LSBs (which are d_0 and $d_{b/2}$, respectively) first.
- 2) Compute values of I and Q for the incoming group $\{d_{b-1}, d_{b-2}, \dots, d_0\}$ as:

$$I = \text{sgn}_I \times \text{val}_I$$

$$Q = \text{sgn}_Q \times \text{val}_Q$$

The values of sgn and val shall be computed as presented in Table 7-61 using bits of I -group to compute I and bits of Q -group to compute Q .

Table 7-61 – Computation rule for sgn and val

I – component	Q – component
<ul style="list-style-type: none"> – compute $\text{sgn}_I = 2 \times d_0 - 1$ – compute $\text{val}_I = I_{b-2} - 2^{b/2-1}$ 	<ul style="list-style-type: none"> – compute $\text{sgn}_Q = 2 \times d_{b/2} - 1$ – compute $\text{val}_Q = Q_{b-2} - 2^{b/2-1}$
<p>NOTE 1 – I_{b-2} and Q_{b-2} are the values of I and Q computed for the incoming $(b-2)$-bit group $\{d_{b-1}, d_{b-2}, \dots, d_{b/2+1}, d_{b/2-1}, \dots, d_1\}$, i.e., with d_0 and $d_{b/2}$ removed.</p> <p>NOTE 2 – The values of I and Q for 2-bit groups shall be as presented in Table 7-59.</p> <p>NOTE 3 – X is the absolute value of X.</p>	

7.1.4.3.1.2 Constellations for odd number of bits

If the number of bits, b , loaded on to the subcarrier is odd (1, 3, 5, 7, 9, 11), constellations with mappings described in this clause shall be used. The support of all the specified odd order constellations (1, 3, 5, 7, 9 and 11) shall be mandatory at the transmitter. The support of all the specified odd order constellations with $b \geq 5$, shall be optional at the receiver.

For multicast transmission, odd constellations with $b \geq 5$ shall not be used.

Constellation and mapping for $b = 1$ shall be as presented in Figure 7-19.

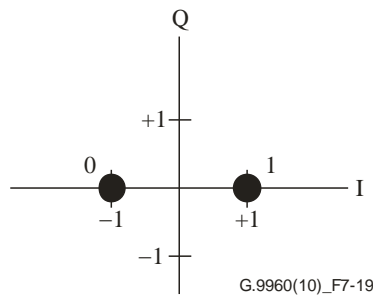

Figure 7-19 – Constellation shape and mapping for $b = 1$

Constellation and mapping for $b = 3$ shall be as presented in Figure 7-20.

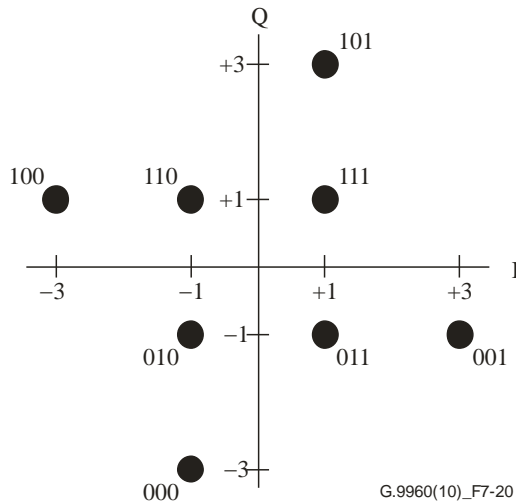

Figure 7-20 – Constellation and mapping for $b = 3$

For $b > 3$ cross-shaped constellations shall be used. First, 2^b constellation points shall be set as a rectangle, with $M_I = 2^{B1}$ columns (M_I points on the I -axis) and $M_Q = 2^{B2}$ rows (M_Q points on the Q -axis), where $B1 = \text{ceiling}(b/2)$ and $B2 = \text{floor}(b/2)$. The mapping of these points shall be computed using the following steps:

- 1) Divide the incoming group of bits into two subgroups, so that $B1$ LSBs form the first subgroup (I -group) and $B2$ MSBs form the second subgroup (Q -group); both subgroups are incoming LSBs (which are d_0 and d_{B2+1} , respectively) first.
- 2) Compute values of I and Q of a rectangular constellation for the incoming group $\{d_{b-1}, d_{b-2}, \dots, d_0\}$ as:

$$I = \text{sgn}_I \times \text{val}_I$$

$$Q = \text{sgn}_Q \times \text{val}_Q$$

The values of sgn and val shall be computed as presented in Table 7-62 using bits of I -group to compute I and bits of Q -group to compute Q .

Table 7-62 – Computation rule for *sgn* and *val*

<i>I</i> – component	<i>Q</i> – component
– compute $sgn_I = 2 \times d_0 - 1$	– compute $sgn_Q = 2 \times d_{B1} - 1$
– compute $val_I = I_{2 \times B1} $	– compute $val_Q = Q_{2 \times B2} $
NOTE 1 – $I_{2 \times B1}$ is the value of <i>I</i> for $(2 \times B1)$ -bit group $\{0, d_{b-1}, d_{b-2}, \dots, d_0\}$ computed as defined in Table 7-61.	
NOTE 2 – $Q_{2 \times B2}$ is the value of <i>Q</i> for $(2 \times B2)$ -bit group $\{d_{b-1}, d_{b-2}, \dots, d_1\}$ computed as defined in Table 7-61.	
NOTE 3 – $ X $ is the absolute value of <i>X</i> .	

- 3) Transform $s = (M_I - M_Q)/4$ columns of constellation points in each quadrant having highest absolute values of *I* (positive or negative) into rows of *Q* by changing their $\{I, Q\}$ coordinates to $\{I', Q'\}$ in the following way:
- $|Q'| = |I| - 2s$, and $sign(Q') = sign(I)$;
 - $|I'| = M_Q - |Q|$, and $sign(I') = sign(Q)$.

The described transformation of $\{I, Q\}$ coordinates for $b = 7$ is presented in Figure 7-21 with $B1 = 4$ and $B2 = 3$ (the MSB and LSB in Figure 7-21 are separated by "/").

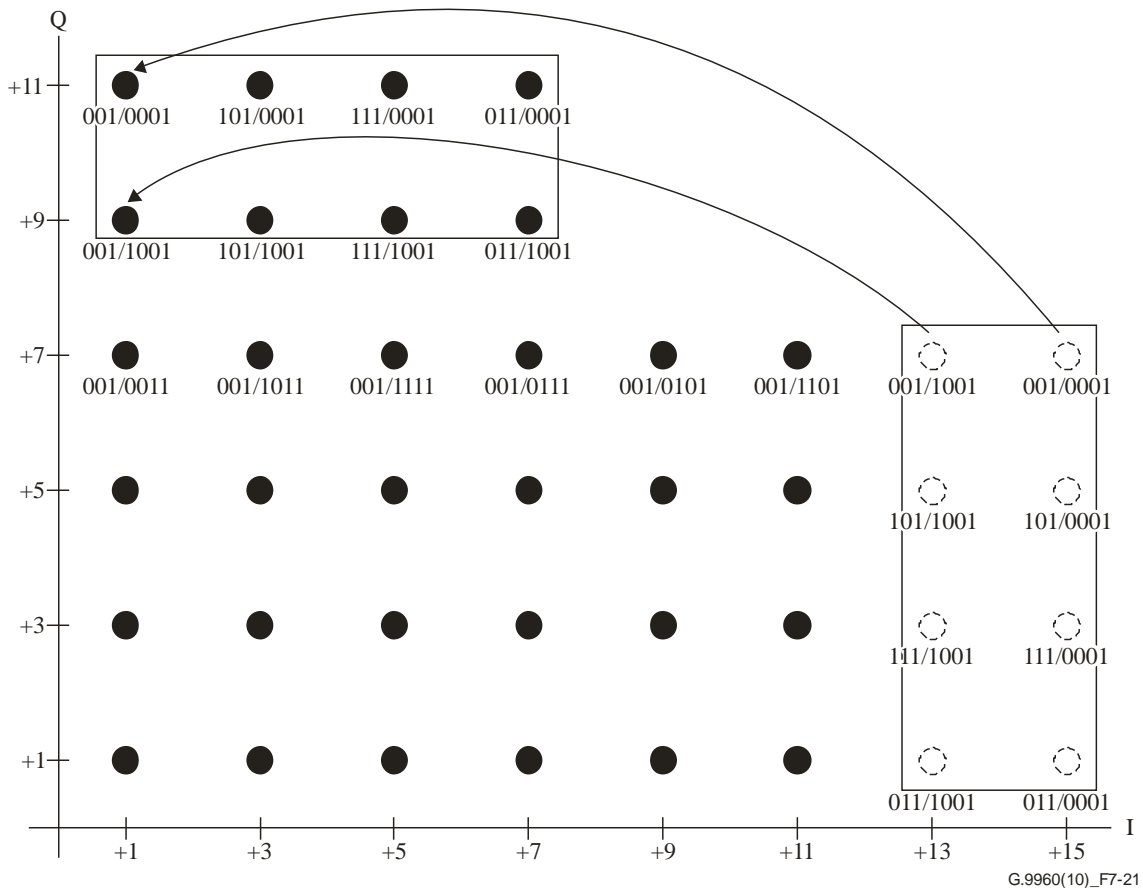

Figure 7-21 – Transformation of rectangular constellation into cross-shaped constellation for $b = 7$ (first quadrant)

7.1.4.3.2 Constellation point scaling

Each constellation point (I, Q) , corresponding to the complex value $I + jQ$ at the output of the constellation mapper, shall be scaled by the power-normalization factor $\chi(b)$, the frequency-domain spectrum shaping coefficient tss , and the gain adjuster g :

$$Z = \chi(b) \times tss \times g \times (I + jQ)$$

7.1.4.3.2.1 Power normalization factor

The values (I , Q) for each constellation point of each subcarrier shall be scaled such that all constellations, regardless of their size, have the same average power. The required scaling, $\chi(b)$, for a subcarrier with b -bit loading depends only on the value of b and shall be set as presented in Table 7-63.

Table 7-63 – Power normalization factor

Number of bits loaded (b)	Scaling factor (χ) (linear scale)
1	1
2	$1/\sqrt{2}$
3	$1/\sqrt{6}$
4	$1/\sqrt{10}$
5	$1/\sqrt{20}$
6	$1/\sqrt{42}$
7	$1/\sqrt{82}$
8	$1/\sqrt{170}$
9	$1/\sqrt{330}$
10	$1/\sqrt{682}$
11	$1/\sqrt{1322}$
12	$1/\sqrt{2730}$

7.1.4.3.2.2 Transmit spectrum shaping

Frequency-domain spectrum shaping of the transmit signal is achieved by a scaling factor tss defined for each subcarrier. The tss values are set by the transmitter and shall be in the range between 0 and –30 dB in steps of –0.5 dB. Smaller values of tss provide attenuation and the value $tss = 0$ dB corresponds to no power attenuation on the particular subcarrier. If no spectrum shaping is applied, the tss values shall be equal to 0 dB for all subcarriers. The values of tss_i are relevant only for subcarriers that are actually transmitted (not masked), and shall be ignored for masked subcarriers (see clause 5.2 of [\[ITU-T G.9964\]](#)).

The communication protocol to convey the tss values used by the transmitter is for further study.

7.1.4.3.2.3 Gain adjustment

The gain adjuster g is intended for fine gain adjustment of the power transmitted at a particular subcarrier, which may be used to equalize the SNR margin over all subcarriers.

The value of gain adjuster shall be set to one. Other values are left for further study.

7.1.4.3.3 Constellation scrambler

The phase of constellation points generated by the constellation mapper shall be shifted in accordance with the pseudorandom sequence generated by a linear feedback shift register (LFSR) generator, as shown in Figure 7-22.

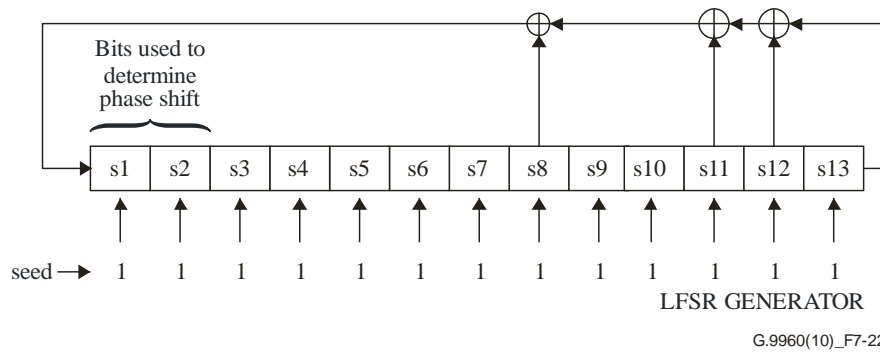

Figure 7-22 – Constellation scrambler

The LFSR generator shall implement the polynomial $g(x) = x^{13} + x^{12} + x^{11} + x^8 + 1$ and shall be advanced by 2 bits for each subcarrier. Bits shall be assigned to subcarriers in order of logical index (see clause 7.1.4.1). The two LSBs of the register shall be taken to determine the phase shift as shown in Table 7-64.

For the header, ACE and payload, the shift of the LFSR for subcarrier index i shall be $2i$ (for both SSC and MSC). Two LFSR bits corresponding to the subcarrier index 0 are (s_1, s_2) of the initialization seed. Two LFSR bits corresponding to the subcarrier index 1 are (s_1, s_2) after two shifts, and so on. For preamble, INUSE, PR and NACK signal, the shift of the LFSR for subcarrier index $(i \cdot k_m)$ shall be $2i$ where k_m denotes the subcarrier spacing multiplier for preamble section m (see clause 7.1.4.5.3.1.1).

Table 7-64 – Constellation phase shift versus LFSR output

LFSR output		Phase shift (rad)
s_2	s_1	
0	0	0
0	1	$\pi/2$
1	0	π
1	1	$3\pi/2$

The LFSR generator shall be initialized with the seed $1FFF_{16}$ for each OFDM symbol. The LSB of the seed corresponds to s_1 . The constellation scrambling shall be applied to the PHY-frame header, ACE and all payload symbols by rotating the originally mapped constellation point $Z_{i,l}^0$ by the phase shift θ to obtain the complex value for the $Z_{i,l}$ for input to the IFFT (see clause 7.1.4.4.1).

$$Z_{i,l} = Z_{i,l}^0 \cdot \exp(j\theta)$$

7.1.4.4 OFDM modulator

The OFDM modulator consists of the following major parts: IDFT, cyclic extension, windowing, overlap and add, and frequency up-shift. The incoming signal to the modulator at the l th OFDM symbol in the present frame for a single subcarrier, with index i , is the complex value $Z_{i,l}$ generated by the constellation encoder as described in clause 7.1.4.3 (for symbols of the header and the payload) or by preamble generator as described in clause 7.1.4.5.3 (for symbols of the preamble). Time-domain samples generated by the IDFT, after adding the cyclic prefix and windowing, are frequency up-shifted by F_{US} . The functional diagram of OFDM modulator is presented in Figure 7-23. The RF up-converter facilitates ITU-T G.9960 operation in the RF frequency range.

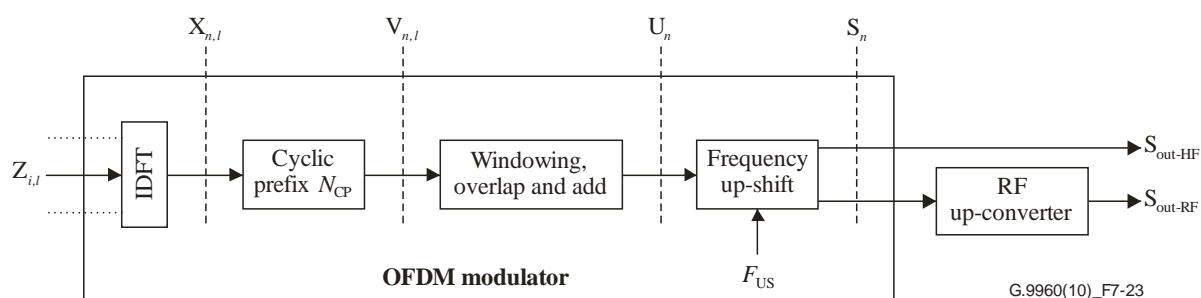

Figure 7-23 – Functional model of the OFDM modulator

The presented functional diagram and other figures presented in this clause do not imply any specific implementation. All aspects of signal processing used in the modulator shall comply with the equations and textual descriptions.

7.1.4.4.1 IDFT

The IDFT converts the stream of the N complex numbers $Z_{i,l}$ at its input into the stream of N complex time-domain samples $x_{n,l}$. The input numbers represent the N mapped blocks of data, where the i th block of data represents the complex value $Z_{i,l}$ of the i th modulated subcarrier of the OFDM signal, where $i = 0, 1, \dots, N-1$ is the subcarrier index and l is the sequential number of the OFDM symbol within the current frame, excluding the preamble. The conversion shall be performed in accordance with the equation:

$$x_{n,l} = \sum_{i=0}^{N-1} \exp\left(j \cdot 2\pi \cdot i \frac{n}{N}\right) \cdot Z_{i,l} \quad \text{for } n = 0 \text{ to } N-1, \quad l = 0 \text{ to } M_F - 1$$

where M_F denotes the total number of OFDM symbols in the current frame excluding the preamble symbols, and the value of N represents the maximum number of possibly modulated subcarriers in the OFDM spectrum and shall be a power of 2: $N = 2^k$, where k shall be an integer. The value of $Z_{i,l}$ for all masked subcarriers shall be set to 0. If some non-masked subcarriers with indices $i < N$ are not loaded with data bits, the corresponding values of $Z_{i,l}$ shall be generated as described in clause 7.1.4.2.6

7.1.4.4.2 Cyclic extension

The cyclic extension provides a guard interval between adjacent OFDM symbols. This guard interval is intended to protect against inter-symbol interference (ISI).

In OFDM, the cyclic prefix of the l th OFDM symbol in the frame shall be implemented by prepending the last $N_{CP}(l)$ samples of the IDFT output to its output N samples to create a pre-overlapped OFDM symbol, as presented in Figure 7-24. The order of samples in the symbol shall be as follows:

- The first sample of the symbol is the IDFT output sample $N - N_{CP}(l)$.
- The last sample of the cyclic prefix is the IDFT output sample $N-1$; the next sample is the IDFT output sample 0.

The l th pre-overlapped OFDM symbol consists of N IDFT samples and $N_{CP}(l)$ cyclic extension, samples, in total:

$$N_W(l) = N + N_{CP}(l) \text{ [samples].}$$

After cyclic extension as described above, time-domain samples at the reference point $v_{n,l}$ in Figure 7-23 shall comply with the following equations:

$$v_{n,l} = x_{n-N_{CP}(l),l} = \sum_{i=0}^{N-1} Z_{i,l} \times \exp\left(j \cdot 2\pi \cdot i \frac{n - N_{CP}(l)}{N}\right) \quad \text{for } n = 0 \text{ to } N_W(l) - 1 = N + N_{CP}(l) - 1$$

The number of IDFT samples, N , and the number of windowed samples, β , shall be the same for all symbols of the same frame. The value of $N_{CP}(l)$ (and the duration of the pre-overlapped OFDM symbol $N_w(l)$, accordingly) may change during the course of the frame, as follows:

- All symbols of the header shall have the value of $N_{GI-HD} + \beta$ defined in clause 7.1.4.6.
- The first two symbols following the header shall have the default value $N_{GI-DF} + \beta$, defined in clause 7.1.4.6.
- All the rest of the payload symbols shall have the same value $N_{GI} + \beta$, where N_{GI} is selected from the valid values defined in clause 7.1.4.6 and indicated in the header, as described in clause 7.1.2.1.

7.1.4.4.3 Symbol timing

The PHY frame consists of a preamble followed by an integer number, M_F , of OFDM symbols. The first symbol following the preamble (the first symbol of the PHY-header) shall have symbol count 0, and the last symbol of the frame shall have symbol count $M_F - 1$. The time position of each symbol in the frame is defined by sample count. The first sample of the symbol with symbol count 0 shall have sample count $M(0) = N_{pr} - \beta$, where N_{pr} is the number of samples in the preamble. The count of the first sample of the l th symbol ($l = 1, 2, \dots, M_F - 1$) in the frame shall be:

$$M(l) = N_{pr} - \beta + \sum_{k=0}^{l-1} N_S(k)$$

where $N_S(k) = N + N_{CP}(k) - \beta$ and $N_S(k)$ may be different for symbols of the header and payload, as described in clause 7.1.4.6.

7.1.4.4.4 Windowing, overlap and add

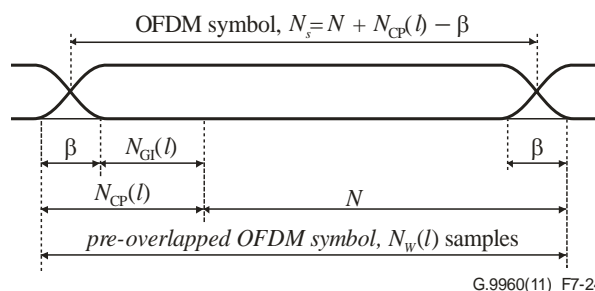

Figure 7-24 – Structure of an OFDM symbol with cyclic extension and overlapped windowing

The first β samples of the cyclic prefix and last β samples of the IDFT output shall be used for shaping the envelope of the transmitted signal (windowing). The window function facilitates PSD shaping: it allows sharp PSD roll-offs used to create deep spectral notches and reduction of the out-of-band PSD. The number of windowed samples, β , shall be the same for all of the payload symbols of the same frame, as well as the PHY-header and preamble.

To reduce the modulation overhead, the windowed samples of adjacent symbols shall overlap, as shown in Figure 7-24. The value of $N_{CP}(l) - \beta = N_{GI}(l)$ forms the guard interval. The duration of the l th OFDM symbol after overlap is thus $N_S(l) = N + N_{CP}(l) - \beta$.

After applying the windowing and the overlap and add functions, the time-domain samples at the reference point u_n in Figure 7-23 shall comply with the following equations:

$$u_n = u_n^{(pr)} + \sum_{l=0}^{M_F-1} w(n - M(l), l) \times u_{n - M(l), l} \quad \text{for } n = 0 \text{ to } M(M_F - 1) + N_w(M_F - 1) - 1$$

where $u_n^{(pr)}$ is the n th sample of the preamble, as defined in clause 7.1.4.5 (note that the signal $u_n^{(pr)}$ already includes windowing as necessary), $w(n,l)$ is the windowing function defined on $N_W(l)$ samples of the pre-overlapped OFDM symbol in the following way:

$$w(n,l) = \begin{cases} w_\beta(n) & 0 \leq n < \beta \\ 1 & \beta \leq n < N_W(l) - \beta \\ w_\beta(N_W(l) - 1 - n) & N_W(l) - \beta \leq n < N_W(l) \\ 0 & \text{otherwise} \end{cases}$$

where $w_\beta(n)$ is the function describing the roll-off section of the window. The roll-off function $w_\beta(n)$ shall be vendor discretionary.

However, $w_\beta(n)$ shall comply with the following rules:

- $w_\beta(n) + w_\beta(\beta - n - 1) = 1$ for $0 \leq n < \beta$.
- $0 \leq w_\beta(n) \leq 1$.

The symbol rate f_{OFDM} (number of symbols per second) and symbol period T_{OFDM} for the given value of N_{CP} and β shall be computed, respectively, as:

$$f_{OFDM} = \frac{N \times F_{SC}}{N + N_{CP} - \beta}$$

and

$$T_{OFDM} = 1/f_{OFDM}$$

7.1.4.4.5 Frequency up-shift

The frequency up-shift offsets the spectrum of the transmit signal shifting it by F_{US} . The value of F_{US} shall be a multiple of the subcarrier frequency F_{SC} :

$$F_{US} = m * F_{SC}, \text{ where } m \text{ is an integer and } N/2 \leq m.$$

The valid values of m are medium dependent and can be calculated from the values given in clause 7.2.

The real and imaginary components of the signal after frequency up-shift (reference point s_n in Figure 7-23) shall be as follows:

$$s_n = u_{n/p} \times \exp\left(j \frac{2\pi mn}{Np}\right) = \text{Re}(s_n) + j \text{Im}(s_n) \quad \text{for } n = 0 \text{ to } [M(M_F - 1) + N_W(M_F - 1)] \times p - 1;$$

$$\text{Re}(s_n) = \text{Re}(u_{n/p}) \cos\left(\frac{2\pi mn}{Np}\right) - \text{Im}(u_{n/p}) \sin\left(\frac{2\pi mn}{Np}\right)$$

$$\text{Im}(s_n) = \text{Re}(u_{n/p}) \sin\left(\frac{2\pi mn}{Np}\right) + \text{Im}(u_{n/p}) \cos\left(\frac{2\pi mn}{Np}\right)$$

where $u_{n/p}$ is u_n after interpolation with factor p . The interpolation factor p is vendor discretionary, and shall be equal to or higher than 2.

NOTE 1 – The minimum value of p sufficient to avoid distortions depends on the ratio between the up-shift frequency F_{US} and the bandwidth of the transmit signal $BW = N * F_{SC}$. It is assumed that an appropriate low-pass filter is included to reduce imaging.

NOTE 2 – The phase of the up-shift should be initialized to zero at the first sample of the preamble and be

advanced by $\frac{2\pi m}{Np}$ per each sample (after interpolation).

7.1.4.4.6 Output signal

For all applications which do not use an RF up-converter (further referred to as HF-applications), the output signal of the modulator shall be the real component of s_n :

$$S_{\text{out-HF}} = \text{Re}(s_n)$$

For RF applications, the RF up-converter shall produce the following output signal:

$$S_{\text{out-RF}}(t) = \text{Re}[s(t) \times \exp(j2\pi F_{UC}t)] = \text{Re}[s(t)] \times \cos(2\pi F_{UC}t) - \text{Im}[s(t)] \times \sin(2\pi F_{UC}t)$$

where F_{UC} is the frequency shift introduced by the RF modulator. The range of F_{UC} and its valid values are specified in clause 7.1.4.6.

After RF up-conversion, the centre frequency around which the spectrum of the transmit OFDM signal will be placed is $F_C = F_{UC} + F_{US}$.

7.1.4.5 Preamble, INUSE, PR, NACK and IDPS signals

7.1.4.5.1 General preamble structure

The preamble is prepended to every PHY frame defined in clause 7.1.2.1. It is intended to assist the receiver in detecting, synchronizing to the frame boundaries, and acquiring the physical layer parameters such as channel estimation and OFDM symbol alignment. The preamble shall meet the same transmit PSD mask (i.e., notches, shapes) as the header and the payload symbols.

Table 7-65 presents the general structure of the ITU-T G.9960 preamble. Each section I comprises N_I repetitions of an OFDM symbol (S_I) employing subcarrier spacing $k_I \times F_{SC}$, where F_{SC} denotes the subcarrier spacing of the payload. A zero value for N_I means that section I is not included in the preamble. The values of k_I shall be selected from the set 1, 2, 4 or 8. The preamble subcarriers of section I shall be one in every k_I subcarriers with respect to the subcarriers used for the payload OFDM symbol starting from subcarrier zero. Each preamble section shall be windowed as necessary in order to comply with the PSD mask. This is illustrated in Figure 7-25.

Table 7-65 – General structure of the preamble

	1st section	2nd section	3rd section
Number of symbols (N_I) (Note 1)	N_1	N_2	N_3
Subcarrier spacing ($k_I \times F_{SC}$)	k_1	$k_2 = k_1$ (Note 2)	k_3
OFDM symbol (S_I)	S_1	$S_2 = -S_1$ (Note 3)	S_3
NOTE 1 – N_I does not include windowing. NOTE 2 – The subcarrier spacing of the 2nd section shall be equal to the subcarrier spacing of the 1st section. NOTE 3 – The OFDM symbol of the 2nd section shall be an inverted time-domain waveform of the 1st section.			

Figure 7-25 shows the ITU-T G.9960 preamble waveform.

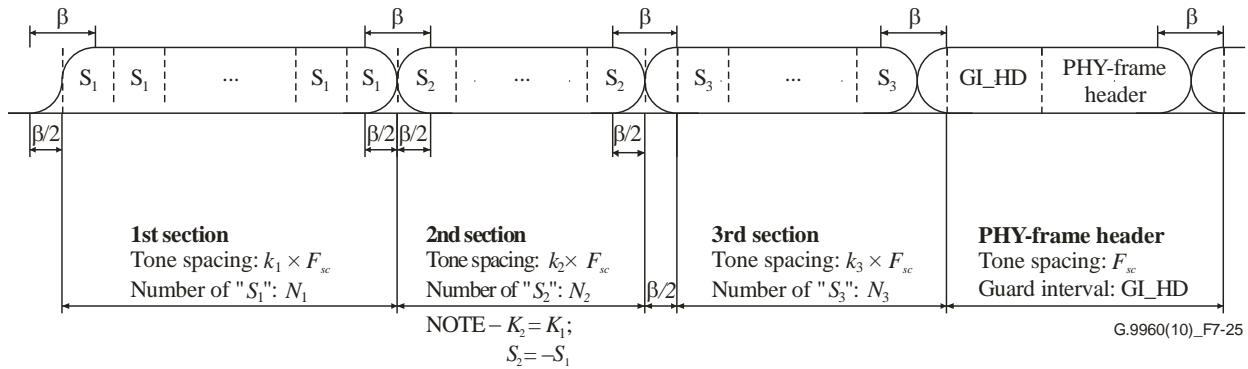

Figure 7-25 – Preamble waveform

The number of repetitions of OFDM symbol S_I (N_I) in each of the preamble sections may be a non-integer number to incorporate an optional guard interval between sections provided that a fraction of N_I is consistent with the guard interval specified in Table 7-67. The specific preamble types and construction methods are defined in clause 7.2.

7.1.4.5.2 INUSE, PR, NACK and IDPS signals general structure

The INUSE, PR, NACK and IDPS general structure (see clause 8.3.3.4 of [ITU-T G.9961]) is composed of a single section.

Table 7-66 – INUSE, PR, NACK and IDPS signal generation parameters

Description	Symbol
Number of symbols (Note)	N_{PRS}
Subcarrier spacing ($k_i \times F_{SC}$)	k_1
OFDM symbol	S_{PRS}
NOTE – N_{PRS} does not include windowing.	

The INUSE, PR, NACK and IDPS signals shall meet the same transmit PSD mask (i.e., notches, shapes) as the preamble symbols and shall be windowed as necessary in order to comply with the PSD mask.

The INUSE, PR, NACK and IDPS signals consist of N_{PRS} repetitions of an OFDM symbol (S_{PRS}) that employs the same subcarrier spacing as the first section of the preamble ($k_1 \times F_{SC}$).

The values for the N_{PRS} parameter are found in the medium specific sub-sections of clause 7.2.

7.1.4.5.3 Preamble, INUSE, PR NACK and IDPS signal generation

This clause contains the description of preamble, INUSE, PR, NACK and IDPS signal generation method, which is not medium dependent. The preamble, INUSE, PR, NACK and IDPS signal generation method specific to the type of medium is described under clause 7.2.

7.1.4.5.3.1 Frequency-domain symbol generation

7.1.4.5.3.1.1 Preamble

The subcarriers of the m th section of the preamble shall be those with indices $0, k_m, 2k_m, 3k_m$, etc. The preamble generator shall output complex values Z_i for each subcarrier following the order given by logical indices i with $i = 0, k_m, 2k_m, \dots$ to be modulated on to symbols of the preamble in accordance with the relevant subcarrier mask.

7.1.4.5.3.1.2 INUSE, PR, NACK and IDPS signals

The subcarrier spacing of the INUSE, PR, NACK and IDPS signals shall be the same as the subcarrier spacing of the first section of the preamble ($k_l \times F_{SC}$). The INUSE, PR, NACK and IDPS signal generator shall output complex values Z'_i for each subcarrier following the order given by logical indices $i = 0, k_l, 2k_l, \dots$ to be modulated on to symbols of the INUSE, PR, NACK and IDPS signal in accordance with the relevant subcarrier mask.

7.1.4.5.3.2 Modulation

7.1.4.5.3.2.1 Modulation of the preamble

For the non-masked subcarriers of the preamble, a bit sequence of all ones shall be mapped using the 1-bit constellation as specified in clause 7.1.4.3.1.2. Other bit sequences are for further study.

The constellation scrambler LFSR generator shall be initialized at the beginning of each one of the used preamble sections to a seed that is section and medium dependent. The default value of the seed is defined in clause 7.2. Additional, 'domain-specific' seeds are also defined in clause 7.2. The seed used shall either be the 'default' seed or a 'domain-specific' seed, as indicated in the "TXOP Attributes Extension Data" of the MAP (see clause 8.8.4.1.1 of [\[ITU-T G.9961\]](#)). Whenever usage of a 'domain-specific' seed is indicated, the appropriate seed shall be selected from the pool of seeds in the tables in clause 7.2 based on the DOD (Domain ID).

NOTE – This mechanism may be used by a DM whenever it detects the presence of a neighbouring network (regardless of the transmission technology being used by the neighbouring network) in order to reduce the level of interference to the neighbouring network.

For preamble generation, the output of the mapper shall be subsequently rotated using the two bits that are the LSBs of the LFSR, s_1 and s_2 , as defined in Table 7-64 (constellation scrambler) resulting in constellation point Z_i .

The LFSR shall be advanced by two bits for each preamble's subcarrier (for both SSC and MSC) in the order specified in clause 7.1.4.3.3.

7.1.4.5.3.2.2 Modulation of the INUSE, PR, NACK and IDPS symbols

The non-masked subcarriers of the INUSE, PR, NACK and IDPS signals shall be modulated using a BPSK sequence, of all ones (P_i). The reference sequence shall be subsequently rotated as specified in clause 7.1.4.3.3 (Constellation scrambler).

The constellation scrambler LFSR generator shall be initialized at the beginning of the INUSE, PR, NACK and IDPS signals to a seed that is medium dependent. The default value of the seed is defined in clause 7.2. Additional, 'domain-specific' seeds are also defined in clause 7.2. The seed used shall either be the 'default' seed or a 'domain-specific' seed, as indicated in the "TXOP Attributes Extension Data" of the MAP (see clause 8.8.4.1.1 of [\[ITU-T G.9961\]](#)). Whenever usage of a 'domain-specific' seed is indicated, the appropriate seed shall be selected from the pool of seeds in the tables of clause 7.2 based on the DOD (Domain ID).

NOTE – This mechanism may be used by a DM whenever it detects the presence of a neighbouring network (regardless of the transmission technology being used by the neighbouring network) in order to reduce the level of interference to the neighbouring network.

For non-masked subcarrier i , Z_i shall be generated by rotating P_i using the two bits that are the LSBs of the LFSR, s_1 , and s_2 , as defined in Table 7-64. The LFSR shall be advanced by two bits for each applicable subcarrier (for both SSC and MSC) in the order specified in clause 7.1.4.3.3.

Z'_i is the complex conjugate of Z_i and Z'_i shall be used to generate the symbol S_{PRS} used in the INUSE, PR, NACK and IDPS signals.

7.1.4.5.3.3 Time-domain symbol generation

7.1.4.5.3.3.1 Preamble

The Z_i values shall be modulated on to OFDM symbols as described in clause 7.1.4.4.1.

The output time-domain symbol shall be repeated N_I times where N_I denotes the number of replicas within section I . If either N_1 or N_3 are non-integer numbers, the fraction of the symbol replica shall be at the beginning of the section. If N_2 is a non-integer number, the fraction of the symbols replica shall be at the end of the section.

The first, second and third sections of the preamble shall be windowed, overlapped and added as described below:

- 1) First section:
 - a) The first short symbol of the first section is cyclically extended by prepending $\beta/2$ samples.
 - b) The last short symbol of the first section is cyclically extended by appending $\beta/2$ samples.
 - c) The first and last β samples of the extended first section are windowed with a window function $w_\beta(n)$ and $w_\beta(\beta-n-1)$ respectively.
- 2) Second section:
 - a) The first short symbol of the second section is cyclically extended by prepending $\beta/2$ samples.
 - b) The last short symbol of the second section is cyclically extended by appending $\beta/2$ samples.
 - c) The first and last β samples of the extended second section are windowed with a window function $w_\beta(n)$ and $w_\beta(\beta-n-1)$ respectively.
- 3) Third section:
 - a) The beginning of the third section is cyclically extended by prepending β samples.
 - b) The first and last β samples of the extended third section are windowed with a window function $w_\beta(n)$ and $w_\beta(\beta-n-1)$ respectively.
- 4) Overlap and add:
 - a) The β windowed samples at the end of the first section and at the beginning of the second section are overlapped and added.
 - b) The β windowed samples at the end of the second section and at the beginning of the third section are overlapped and added.
 - c) The β windowed samples at the end of the third section are overlapped and added with the β windowed samples at the beginning of the PHY-frame header as described in clause 7.1.4.4.4.

$w_\beta(n)$ shall comply with the rules specified in clause 7.1.4.4.4.

This is illustrated in Figure 7-26.

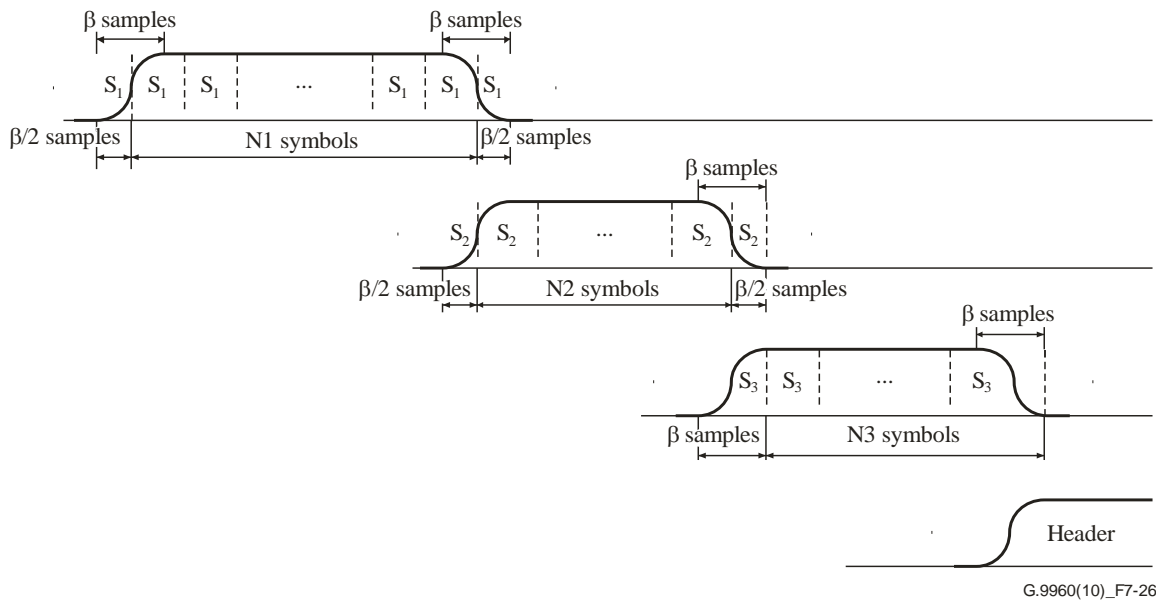

Figure 7-26 – Preamble time-domain generation

The number of samples at the Nyquist rate in the preamble shall be:

$$N_{pr} = \beta + N_1 \frac{N}{k_1} + N_2 \frac{N}{k_2} + N_3 \frac{N}{k_3}$$

7.1.4.5.3.3.2 INUSE, PR, NACK and IDPS signals

For the INUSE, PR, NACK and IDPS signals, the output time domain symbol shall be repeated N_{PRS} times, where N_{PRS} denotes the number of replicas. The Z'_i values shall be modulated on to OFDM symbols as described in clause 7.1.4.4.1.

The INUSE, PR, NACK and IDPS signals shall be windowed as described below:

- 1) The first short symbol of the INUSE, PR, NACK and IDPS signals is cyclically extended by prepending $\beta/2$ samples.
- 2) The last short symbol of the INUSE, PR, NACK and IDPS signals is cyclically extended by appending $\beta/2$ samples.
- 3) The first and last β samples of the extended INUSE, PR, NACK and IDPS signals are windowed with a window function $w_\beta(n)$ and $w_\beta(\beta-n-1)$, respectively.

$w_\beta(n)$ shall comply with the rules specified in clause 7.1.4.4.4.

This is illustrated in Figure 7-27.

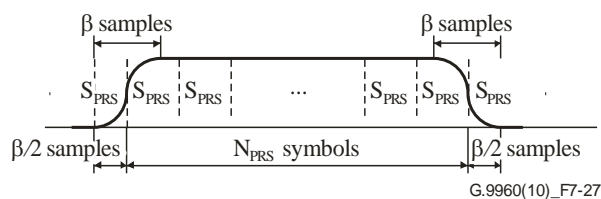

Figure 7-27 – INUSE, PR, NACK and IDPS signals in time domain

The number of samples at Nyquist rate in the INUSE, PR and NACK signals shall be:

$$N_s = \beta + N_{PRS} \frac{N}{k_1}$$

7.1.4.6 PMD control parameters

Table 7-67 summarizes valid values of control parameters of the OFDM modulator described in the clauses above. This list is a superset of parameters used over different media; a list of valid values of modulation parameters and their valid combinations for particular media is presented in clause 7.2.

Table 7-67 – Valid OFDM control parameters

Notation	Parameter	Valid values or range	Note
N	Number of subcarriers	256, 512, 1024, 2048, 4096	
F_{SC}	Subcarrier spacing [kHz]	$24.4140625 \times k$, $k = 1, 2, 4, 8, 16, 32, 64$	
N_{GI}	Guard interval [samples]	$k \times N/32$, $k = 1, 2, 3, \dots 8$	
N_{GI-HD}	Guard interval of the header	$N/4$	
N_{GI-DF}	Default guard interval of the payload	$N/4$	$N_{GI-DF} \geq N_{GI}$
β	Window size [samples]	Any even integer between 0 and $N/4$	Range 0- $N/4$
F_{US}	Up-shift frequency, [kHz]	$m \times F_{SC}$, $m \geq N/2$	m is an integer; valid values of m can be calculated from clause 7.2
F_{UC}	Up-convert frequency, [kHz]	$F_{UC} = l \times F_G$ where valid values for l are a subset of the range of integers between 12 and $100 - (2 \times F_{US}/F_G)$ and $F_G = 25$ MHz	RF applications. Additional constraints on F_{UC} may be specified in regional annexes. In Annex C valid values for l are a subset of the range of integers between 12 and $120 - (2 \times F_{US}/F_G)$ and $F_G = 25$ MHz
NOTE – Guard interval and window size are expressed in samples at Nyquist rate.			

Secondary parameters of the OFDM modulator are presented in Table 7-68.

Table 7-68 – Secondary parameters of the modulator

Notation	Parameter	Note
BW	Total bandwidth [Hz]	$BW = N \times F_{SC}$
N_W	Number of samples in a pre-overlapped OFDM symbol	$N_W = N + N_{CP}$
N_s	Number of samples in an OFDM symbol	$N_s = N + N_{CP} - \beta$
f_{OFDM}	Symbol rate [symbols/s]	$f_{OFDM} = \frac{N \times F_{SC}}{N + N_{CP} - \beta}$
T_{OFDM}	Symbol period [s]	$T_{OFDM} = 1/f_{OFDM}$
N_{GI}	Guard interval	$N_{GI} = N_{CP} - \beta$
F_C	Centre frequency	$F_C = F_{US} + F_{UC}$
f_s	Transmit clock	$f_s = N \times F_{SC}$

7.1.4.7 Symbol boost

Symbols of the preamble and the PHY-frame header may be sent with higher power (boosted) relative to the ACE and payload symbols. For the PHY-frame header, only the first OFDM symbol is subject to symbol boost. The boosting shall be achieved by increasing the power of each active subcarrier in the boosted symbol by the same value in dB with the maximum boost of 3 dB (see Table 8-79.1 in [ITU-T G.9961]).

A domain-wide symbol boost is controlled by the domain master using the same mechanism as the one used to update the PSD shaping as described in clause 8.8.5.5 of [ITU-T G.9961]. If the domain master has not indicated symbol boost, all nodes shall boost the preamble and the first OFDM symbol of the PHY-frame header by 0.8 dB (see Table 8-14 in [ITU-T G.9961]). The PSD ceiling carried in the PHY-frame header shall not include the amount of power boost.

The domain-wide symbol boost setting parameters (see Table 8-79.1 in [ITU-T G.9961]) are not applicable to the transmission of MAP-D/RMAP-D frames. The preamble and the first OFDM symbol of the PHY-frame header of the MAP-D/RMAP-D frames shall each be boosted with a fixed value of 0.8 dB.

The symbol boost shall be allowed only for power-line and telephone-line bandplans.

7.1.5 Transmit PSD mask

Transmit PSD mask (TxPSD) is determined by a subcarrier mask (SM), a PSD shaping mask (PSM), a notching of international amateur radio bands, the limit PSD mask (LPM) defined for each particular medium, and a regional PSD mask (RPM) if specified in a regional annex. Parameters to construct the TxPSD are broadcast by the MAP message (clause 8.8.5 of [ITU-T G.9961]).

See clause 5 of [ITU-T G.9964] for the detailed specification of TxPSD.

Notching of amateur radio bands (see clause 5.3 of [ITU-T G.9964]) is accomplished by configuring one or more SM bands (see clause 5.1 of [ITU-T G.9964]) coinciding with the amateur radio bands, or by using the amateur radio band descriptor (see clause 8.8.5 of [ITU-T G.9961]).

The amateur radio band to be masked in a particular domain is specified in the MAP by the amateur radio band descriptor (see clause 8.8.5 of [ITU-T G.9961]).

A PSD ceiling may be applied by the DM in addition to the TxPSD to the nodes of the domain to impose a limit (i.e., a ceiling function) on the transmit signal via the MAP (see clause 8.8.5.5 of [ITU-T G.9961]).

APSD_MAX is conveyed in the PHY frame header to the receiver..

7.1.6 Electrical specifications

7.1.6.1 Transmit clock tolerance

The tolerance of the transmit clock (defined in Table 7-68) shall not exceed ± 50 ppm, including aging.

7.1.6.2 Relative transmit clock accuracy

All nodes shall synchronize the frequency of their transmit clocks to a domain master clock (see the NTR field of the PHY frame header in clause 7.1.2.3.2.1.2). If a node can decode the MAP frame reliably, it shall synchronize its transmit clock with that of the domain master, and the difference between the clocks shall not exceed ± 0.5 ppm. Otherwise, it shall synchronize its transmit clock with that of the node transmitting the RMAP frame. In this case, the difference between the transmit clock frequency of this node and that of the node transmitting the RMAP frame shall not exceed ± 0.5 ppm.

Nodes that are not synchronized with a domain master either directly or through a relay node shall not transmit.

These accuracy requirements shall apply to all bandplans and media types.

7.1.6.3 Up-convert frequency tolerance

The up-convert frequency and transmit clock frequency shall be derived from the same reference clock source, hence they share the same tolerance requirement.

7.2 Medium dependent specification

7.2.1 Physical layer specification over telephone lines

7.2.1.1 Control parameters

See clause 6.1.1 of [ITU-T G.9964].

7.2.1.2 Preamble, INUSE, PR and NACK signals

7.2.1.2.1 Preamble structure

Table 7-69 illustrates the preamble structure for a telephone line.

Table 7-69 – Preamble structure for baseband transmission over telephone lines

	1st section	2nd section	3rd section
Number of symbols (N_i)	8	2	0
Subcarrier spacing ($k_i \times F_{SC}$)	$k_i = 8$	$k_i = 8$	$k_i = 0$

7.2.1.2.2 INUSE, PR and NACK signal generation parameters for telephone lines

Table 7-70 illustrates the INUSE, PR and NACK signal generation parameters for telephone lines.

Table 7-70 – INUSE, PR and NACK signal generation parameters for telephone lines

Parameter	Value
Number of symbols (N_{PRS})	7
Subcarrier spacing ($k_i \times F_{SC}$)	8

7.2.1.2.3 Modulation of the preamble for telephone lines

When using a "default" seed, the constellation scrambler LFSR generator (see clause 7.1.4.3.3) shall be initialized at the beginning of each one of the used preamble sections to a seed that is section dependent as defined in Table 7-71.

When using a "domain-specific" seed, the constellation scrambler LFSR generator (see clause 7.1.4.3.3) shall be initialized at the beginning of each one of the used preamble sections to a seed defined by the DM in the DM_Defined_Seed field of the additional domain information subfield (see clause 8.8.5.15 of [ITU-T G.9961]). The DM shall choose the seed from the set of seeds corresponding to the DOD of the domain, as specified in Table 7-71.1).

Table 7-71 – Default constellation scrambler initialization seed values for the preamble, for telephone lines

Medium	1st section	3rd section
Telephone line	0127 ₁₆	N/A

Table 7-71.1 – Set of domain-specific constellation scrambler initialization seed values for the preamble, for telephone lines

DOD (Domain ID)	1st Section	3rd Section
0	024E ₁₆ ; 17A9 ₁₆ ; 0F53 ₁₆ ; 10F3 ₁₆ ; 1545 ₁₆ ; 01E6 ₁₆ ; 0A8A ₁₆ ; 098E ₁₆	N/A
1	06B2 ₁₆ ; 17C9 ₁₆ ; 00A7 ₁₆ ; 131C ₁₆ ; 0D64 ₁₆ ; 0F93 ₁₆ ; 014F ₁₆ ; 14FC ₁₆	N/A
2	044C ₁₆ ; 0B96 ₁₆ ; 040D ₁₆ ; 0119 ₁₆ ; 037E ₁₆ ; 0074 ₁₆ ; 1A7E ₁₆ ; 0226 ₁₆	N/A
3	1E0E ₁₆ ; 172C ₁₆ ; 081B ₁₆ ; 0232 ₁₆ ; 06FC ₁₆ ; 00E8 ₁₆ ; 1C1D ₁₆ ; 1ADE ₁₆	N/A
4	1B5B ₁₆ ; 05B3 ₁₆ ; 084F ₁₆ ; 0029 ₁₆ ; 0637 ₁₆ ; 121E ₁₆ ; 1EFB ₁₆ ; 102F ₁₆	N/A
5	154F ₁₆ ; 14C7 ₁₆ ; 0CDE ₁₆ ; 0880 ₁₆ ; 09AC ₁₆ ; 096B ₁₆ ; 0D6F ₁₆ ; 0DAD ₁₆	N/A
6	02D9 ₁₆ ; 0427 ₁₆ ; 1014 ₁₆ ; 131B ₁₆ ; 180B ₁₆ ; 043D ₁₆ ; 1DF6 ₁₆ ; 005F ₁₆	N/A
7	0A9E ₁₆ ; 098F ₁₆ ; 19BD ₁₆ ; 1100 ₁₆ ; 1358 ₁₆ ; 12D7 ₁₆ ; 1016 ₁₆ ; 02DE ₁₆	N/A

Table 7-71.1 – Set of domain-specific constellation scrambler initialization seed values for the preamble, for telephone lines

DOD (Domain ID)	1st Section	3rd Section
8	0B14 ₁₆ ; 1437 ₁₆ ; 0AF6 ₁₆ ; 15CF ₁₆ ; 1E04 ₁₆ ; 0CDF ₁₆ ; 14AF ₁₆ ; 1530 ₁₆	N/A
9	1B55 ₁₆ ; 085F ₁₆ ; 0592 ₁₆ ; 1B2A ₁₆ ; 1E42 ₁₆ ; 07E8 ₁₆ ; 1503 ₁₆ ; 0F10 ₁₆	N/A
10	038A ₁₆ ; 0A34 ₁₆ ; 1878 ₁₆ ; 1170 ₁₆ ; 03E4 ₁₆ ; 1251 ₁₆ ; 0253 ₁₆ ; 0F66 ₁₆	N/A
11	0ADE ₁₆ ; 069D ₁₆ ; 0583 ₁₆ ; 08E9 ₁₆ ; 054A ₁₆ ; 0397 ₁₆ ; 016F ₁₆ ; 058A ₁₆	N/A
12	0A1B ₁₆ ; 157B ₁₆ ; 1AE7 ₁₆ ; 0F02 ₁₆ ; 066F ₁₆ ; 0A57 ₁₆ ; 0A98 ₁₆ ; 0DAA ₁₆	N/A
13	042F ₁₆ ; 12C9 ₁₆ ; 1D95 ₁₆ ; 01FC ₁₆ ; 1C85 ₁₆ ; 0FD0 ₁₆ ; 0A06 ₁₆ ; 1E20 ₁₆	N/A
14	0715 ₁₆ ; 1469 ₁₆ ; 10F0 ₁₆ ; 02E1 ₁₆ ; 07C9 ₁₆ ; 04A3 ₁₆ ; 04A6 ₁₆ ; 1ECC ₁₆	N/A
15	15BC ₁₆ ; 0D3A ₁₆ ; 0B06 ₁₆ ; 11D2 ₁₆ ; 0A95 ₁₆ ; 072F ₁₆ ; 03F9 ₁₆ ; 1C49 ₁₆	N/A

7.2.1.2.4 Modulation of the INUSE, PR and NACK signals for telephone lines

The constellation scrambler LFSR generator shall be initialized at the beginning of the INUSE, PR and NACK signals to the same seed used for the 1st preamble section, as defined in Tables 7-71 ('default' seed) and Table 7-71.1 ('domain-specific' seeds).

7.2.1.3 PSD mask specifications

See clause 6.1.2 of [ITU-T G.9964].

7.2.1.4 Permanently masked subcarriers

See clause 6.1.3 of [ITU-T G.9964].

7.2.2 Physical layer specification over power lines

7.2.2.1 Control parameters

See clause 6.2.1 of [ITU-T G.9964].

7.2.2.2 Preamble, INUSE, PR, NACK and IDPS signal

7.2.2.2.1 Preamble structure

Table 7-72 illustrates the preamble structure for baseband transmission over power lines.

Table 7-72 – Preamble structure for baseband transmission over power lines

	1st section	2nd section	3rd section
Number of symbols (N_i)	7	2	0
Subcarrier spacing ($k_i \times F_{SC}$)	$k_i = 8$	$k_i = 8$	$k_i = 0$

7.2.2.2.2 INUSE, PR, NACK and IDPS signal generation parameters for power lines

Table 7-73 illustrates the INUSE, PR and NACK signal generation parameters for power line baseband.

Table 7-73 – INUSE, PR, NACK and IDPS signal generation parameters for power line baseband

Parameter	Value
Number of symbols (N_{PRS})	6
Subcarrier spacing ($k_i \times F_{SC}$)	8

7.2.2.2.3 Modulation of the preamble for power lines

When using a ‘default’ seed, the constellation scrambler LFSR generator (see clause 7.1.4.3.3) shall be initialized at the beginning of each one of the used preamble sections to a seed that is section dependent as defined in Table 7-74.

When using a "domain-specific" seed, the constellation scrambler LFSR generator (see clause 7.1.4.3.3) shall be initialized at the beginning of each one of the used preamble sections to a seed defined by the DM in the DM_Defined_Seed field of the additional domain information auxiliary information field (see clause 8.8.5.15 of [ITU-T G.9961]). The DM shall choose the seed from the set of seeds corresponding to the DOD of the domain, as specified in Table 7-75).

Table 7-74 – Default constellation scrambler initialization seed values for the preamble, for power lines

Medium	1st section	3rd section
Power-line (Baseband)	05FA ₁₆	N/A

Table 7-75 – Set of domain-specific constellation scrambler initialization seed values for the preamble, for power-line baseband

DOD (Domain ID)	1st Section	3rd Section
0	000A ₁₆ ; 158A ₁₆ ; 080D ₁₆ ; 1BF7 ₁₆ ; 08B8 ₁₆ ; 087E ₁₆ ; 0D53 ₁₆ ; 0201 ₁₆	N/A
1	0227 ₁₆ ; 08E8 ₁₆ ; 0D14 ₁₆ ; 0005 ₁₆ ; 10FE ₁₆ ; 1B33 ₁₆ ; 150E ₁₆ ; 145B ₁₆	N/A
2	0408 ₁₆ ; 0507 ₁₆ ; 182E ₁₆ ; 01AB ₁₆ ; 0987 ₁₆ ; 1CCE ₁₆ ; 08B0 ₁₆ ; 1A25 ₁₆	N/A
3	06E2 ₁₆ ; 05E8 ₁₆ ; 135C ₁₆ ; 1907 ₁₆ ; 0113 ₁₆ ; 1635 ₁₆ ; 0A88 ₁₆ ; 19AB ₁₆	N/A
4	07FD ₁₆ ; 02A9 ₁₆ ; 0173 ₁₆ ; 19CD ₁₆ ; 0936 ₁₆ ; 00CA ₁₆ ; 0EC3 ₁₆ ; 1037 ₁₆	N/A

Table 7-75 – Set of domain-specific constellation scrambler initialization seed values for the preamble, for power-line baseband

DOD (Domain ID)	1st Section	3rd Section
5	094D ₁₆ ; 0F04 ₁₆ ; 1791 ₁₆ ; 16BA ₁₆ ; 155A ₁₆ ; 0895 ₁₆ ; 0537 ₁₆ ; 189B ₁₆	N/A
6	0A98 ₁₆ ; 1EFE ₁₆ ; 1DB9 ₁₆ ; 14D7 ₁₆ ; 0AF1 ₁₆ ; 1B73 ₁₆ ; 1C5E ₁₆ ; 166F ₁₆	N/A
7	0B0E ₁₆ ; 0B26 ₁₆ ; 0614 ₁₆ ; 1E7D ₁₆ ; 089A ₁₆ ; 1922 ₁₆ ; 1DD7 ₁₆ ; 1D91 ₁₆	N/A
8	0D0A ₁₆ ; 1843 ₁₆ ; 0D12 ₁₆ ; 0F1D ₁₆ ; 07BA ₁₆ ; 19C0 ₁₆ ; 08E4 ₁₆ ; 0984 ₁₆	N/A
9	0F88 ₁₆ ; 10A8 ₁₆ ; 050C ₁₆ ; 1B6C ₁₆ ; 183F ₁₆ ; 0509 ₁₆ ; 0FFA ₁₆ ; 1221 ₁₆	N/A
10	12EE ₁₆ ; 0BE8 ₁₆ ; 0F4B ₁₆ ; 156E ₁₆ ; 0D0C ₁₆ ; 1312 ₁₆ ; 1A56 ₁₆ ; 0BD0 ₁₆	N/A
11	1300 ₁₆ ; 0E3A ₁₆ ; 02D3 ₁₆ ; 003F ₁₆ ; 18EF ₁₆ ; 06AC ₁₆ ; 0AB6 ₁₆ ; 0CF5 ₁₆	N/A
12	14F0 ₁₆ ; 1C18 ₁₆ ; 122A ₁₆ ; 0233 ₁₆ ; 132F ₁₆ ; 051F ₁₆ ; 1973 ₁₆ ; 01AD ₁₆	N/A
13	1A2D ₁₆ ; 1ABF ₁₆ ; 0988 ₁₆ ; 1DA4 ₁₆ ; 1DCB ₁₆ ; 0CFB ₁₆ ; 065B ₁₆ ; 1FAA ₁₆	N/A
14	1CCF ₁₆ ; 138B ₁₆ ; 1F00 ₁₆ ; 153B ₁₆ ; 1D56 ₁₆ ; 008D ₁₆ ; 01C4 ₁₆ ; 17CF ₁₆	N/A
15	1CE7 ₁₆ ; 11D6 ₁₆ ; 0D59 ₁₆ ; 05CE ₁₆ ; 18C4 ₁₆ ; 06CF ₁₆ ; 0F68 ₁₆ ; 1782 ₁₆	N/A

7.2.2.2.4 Modulation of the INUSE, PR and NACK signals for power lines

The constellation scrambler LFSR generator shall be initialized at the beginning of the INUSE, PR and NACK signals to the same seed used for the 1st preamble section, as defined in Table 7-74 ('default' seed) and Table 7-75 ('domain-specific' seeds).

7.2.2.2.5 Modulation of the IDPS signal for power lines

The inter-domain presence signal (IDPS) is used for the neighbouring domain interference mitigation (NDIM) mechanism (see clause 8.14 in [ITU-T G.9961]).

The IDPS signal shall be generated in the same way as INUSE, PR and NACK signals (see clause 7.1.4.5.3.1.2, clause 7.1.4.5.3.2.2 and clause 7.1.4.5.3.3.2).

The constellation scrambler LFSR generator shall be initialized at the beginning of the IDPS signal to the seed 166C₁₆.

7.2.2.3 PSD mask specifications

See clause 6.2.2 of [ITU-T G.9964].

7.2.2.4 Permanently masked subcarriers

See clause 6.2.3 of [ITU-T G.9964].

7.2.3 Physical layer specification over coax

7.2.3.1 Control parameters

See clause 6.3.1 of [ITU-T G.9964].

7.2.3.2 Preamble, PR signal, and INUSE signal

7.2.3.2.1 Preamble structure

Table 7-76 illustrates the preamble structure for coax baseband.

Table 7-76 – Preamble structure for baseband transmission over coax

	1st section	2nd section	3rd section
Number of symbols (N_i)	10	4	2.5
Subcarrier spacing ($k_i \times F_{SC}$)	$k_i = 4$	$k_i = 4$	$k_i = 1$

Table 7-77 illustrates the preamble structure for coax RF.

Table 7-77 – Preamble structure for RF transmission over coax

	1st section	2nd section	3rd section
Number of symbols (N_i)	10	4	2.5
Subcarrier spacing ($k_i \times F_{SC}$)	$k_i = 4$	$k_i = 4$	$k_i = 1$

7.2.3.2.2 INUSE, PR and NACK signal generation parameters for coax

Table 7-78 illustrates the INUSE, PR and NACK signal generation parameters for coax baseband.

Table 7-78 – INUSE, PR and NACK signal generation parameters for coax baseband

Parameter	Value
Number of symbols (N_{PRS})	9
Subcarrier spacing ($k_i \times F_{SC}$)	4

Table 7-79 illustrates the INUSE, PR and NACK signal generation parameters for coax RF.

Table 7-79 – INUSE, PR and NACK signal generation parameters for coax RF

Parameter	Value
Number of Symbols (N_{PRS})	9
Subcarrier spacing ($k_i \times F_{SC}$)	4

7.2.3.2.3 Modulation of the preamble for coax

When using a "default" seed, the constellation scrambler LFSR generator (see clause 7.1.4.3.3) shall be initialized at the beginning of each one of the used preamble sections to a seed that is section dependent as defined in Table 7-80.

When using a "domain-specific" seed, the constellation scrambler LFSR generator (see clause 7.1.4.3.3) shall be initialized at the beginning of each one of the used preamble sections to a set of seeds defined by the DM in the DM_Defined_Seed field of the additional domain information subfield (see clause 8.8.5.15 of [ITU-T G.9961]).

Table 7-80 – Default constellation scrambler initialization seed values for the preamble, for coax

Medium	1st section	3rd section
Coax (Baseband)	16E6 ₁₆	1105 ₁₆
Coax (RF)	1C62 ₁₆	12C4 ₁₆

Domain-specific constellation scrambler initialization seed values for the preamble for both coax (baseband) and coax (RF) are for further study.

7.2.3.2.4 Modulation of the INUSE, PR and NACK signals for coax

The constellation scrambler LFSR generator (see clause 7.1.4.3.3) shall be initialized at the beginning of the INUSE, PR and NACK signals to the same seed used for the 1st preamble section, as defined in Table 7-80.

7.2.3.3 PSD mask specifications

See clause 6.3.2 of [ITU-T G.9964].

7.2.3.4 Permanently masked subcarriers

See clause 6.3.3 of [ITU-T G.9964].

7.2.3.5 Coexistence on coax

See clause 6.3.4 of [ITU-T G.9964].

7.2.4 Transmitter EVM requirements

The deviation of the actual transmit signal from the corresponding constellation point shall be estimated by the value of error vector magnitude (EVM) calculated as:

$$EVM = 20 \log \frac{\text{error_vector_RMS}}{\text{reference_signal}}$$

The interpretation of EVM components for a constellation point is illustrated in Figure 7-28.

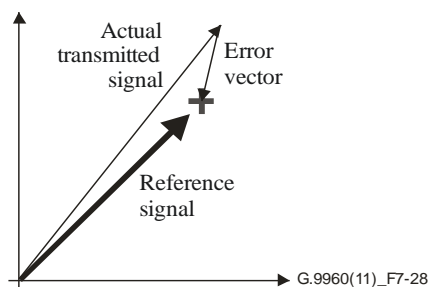

Figure 7-28 – Interpretation of EVM

The EVM for a subcarrier at the output of a transceiver (i.e., at the MDI reference point), for at least 90% of active subcarriers, shall not exceed values presented in Table 7-81 at the maximum transmit power that the transceiver is capable of transmitting within a transmit PSD mask.

Table 7-81 – Maximum EVM values for different media and bandplans

Medium	EVM (Note 1)
Baseband power line (Note 2)	–33 dB for $f \leq 30$ MHz –3 dB for $f > 30$ MHz
Telephone line	–40 dB
Baseband coax	–40 dB
RF coax	–28 dB
NOTE 1 – Values of EVM shall be verified using standard termination impedance for each type of medium (see clause 7.2.5).	
NOTE 2 – EVM for LCP shall be –20 dB for all frequency ranges.	

7.2.5 Termination impedance

See clause 6.4 of [\[ITU-T G.9964\]](#).

7.2.6 Total transmit power

See clause 6.5 of [\[ITU-T G.9964\]](#).

7.2.7 Receiver input impedance

See clause 6.6 of [\[ITU-T G.9964\]](#).

7.2.8 Longitudinal conversion loss

The longitudinal conversion loss (LCL) of telecommunication lines or telecommunication ports is a measure of the degree of unwanted transversal signal produced at the terminals of the G.hn device due to the presence of a longitudinal signal on the connecting leads.

The longitudinal voltage (V_{cm}) to transversal voltage (V_{diff}) ratio shall be measured in accordance with [\[ITU-T G.117\]](#) and [\[ITU-T O.9\]](#). During the measurement, the transceiver under test shall be powered, and in L1 mode (see clause 8.21 of [\[ITU-T G.9961\]](#)).

$$LCL = 20 \log_{10} \left| \frac{V_{cm}}{V_{diff}} \right| \text{ dB}$$

The specification of LCL for mediums other than phonenumber is for further study.

7.2.7.1 LCL for phonenumber

The LCL of the G.hn transceiver shall be greater than or equal to 38 dB in the frequency band up to 12 MHz. The LCL above 12 MHz is for further study. The termination impedance of the transceiver for LCL measurement shall be the one corresponding to the phonenumber medium as stated in Table 6-11 of [\[ITU-T G.9964\]](#). The LCL shall be measured at the MDI interface. LCL shall be measured in the frequency band between the lowest frequency (StartSubCarrier) and the highest frequency (StopSubCarrier) used by the transmitter (see Table 8-16.6 of [\[ITU-T G.9961\]](#)).

NOTE – The equipment balance should be better than the anticipated access network balance in order to minimize the unwanted emissions and susceptibility to external RFI.

Annex A

Regional requirements for North America

(This annex forms an integral part of this Recommendation.)

For further study.

Annex B

(This annex has been intentionally left blank.)

Annex C

Regional requirements for Japan

(This annex forms an integral part of this Recommendation.)

C.1 Scope

This annex describes domestic practices, standards for each medium (coax cable, telephone line and power line) and the way to apply the ITU-T G.9960 system under those conditions in Japan.

C.2 Medium dependent specification

C.2.1 Physical layer specification over telephone lines

For further study.

C.2.2 Physical layer specification over power lines

All nodes over power lines shall comply with national regulations in Japan [b-Regulations], which states that the frequency band that can be used without any licence is restricted to between 2 MHz and 30 MHz, and the interference level due to power-line communication is also restricted. Through experiments and evaluations, Japan set these regulations that are not the same as the description given in clause 7.2.2.

Furthermore, the regulations give limitations of where they can be used; that is, the usage of power-line communications is only allowed inside buildings and is not allowed outside buildings.

C.2.3 Physical layer specification over coax

C.2.3.1 Bandplan

In addition to the OFDM control parameters in Table 6-6 of [ITU-T G.9964], the OFDM control parameters shown in Table C.1 may be used. It should be noted that the ITU-T G.9960 signals over coax cables should not interfere with services offered in the coax cables to customers by the cable television operators, or with signals transmitted from receiving antennas of terrestrial and satellite broadcasting in the coax cables.

Table C.1 – Optional OFDM control parameters for coax cables in Japan

Domain type	Coax RF
Bandplan name	200 MHz-CRF (Notes 2, 3)
N	1024
F_{SC}	195.3125 kHz
N_{GI}	$K \times N/32$, $k = 1,2,3, \dots, 8$ samples @ 200 Msamples/s
N_{GI-HD}	$N/4 = 256$ samples @ 200 Msamples/s
N_{GI-DF}	$N/4 = 256$ samples @ 200 Msamples/s
β	32
F_{US}	100 MHz
F_{UC}	Z (Note 4)

Table C.1 – Optional OFDM control parameters for coax cables in Japan

Domain type	Coax RF
Bandplan name	200 MHz-CRF (Notes 2, 3)
Subcarrier indexing rule (Note 1)	Rule #1 if $X = Y = Z$, or rule #2 if $X + 25 \text{ MHz} = Y + 50 \text{ MHz} = Z + 100 \text{ MHz}$ (Note 5)
<p>NOTE 1 – See clause 7.1.4.1 for more details on subcarrier indexing rules.</p> <p>NOTE 2 – The 200 MHz bandplan on this table and the 50 MHz and 100 MHz bandplans shown in Table 6-6 of [ITU-T G.9964] may be used by nodes operating in the same coax RF domain.</p> <p>NOTE 3 – The range of subcarrier frequencies is between Z MHz and $(Z + 200)$ MHz.</p> <p>NOTE 4 – The values of F_{UC} shall be selected from the valid set defined in Table 7-67 and may be subject to regional spectrum management rules.</p> <p>NOTE 5 – X and Y are F_{UC} of bandplan 50 MHz-CRF and 100 MHz-CRF respectively (see Table 6-6 of [ITU-T G.9964]).</p>	

C.2.3.2 Preamble

This is the same as clause 7.2.3.2.

C.2.3.3 PSD mask specifications

Limit PSD masks for operation over RF coax are specified for the frequency range between 770 MHz and 1032 MHz and above 2070 MHz. Specifications of the limit PSD mask for other frequency bands are for further study.

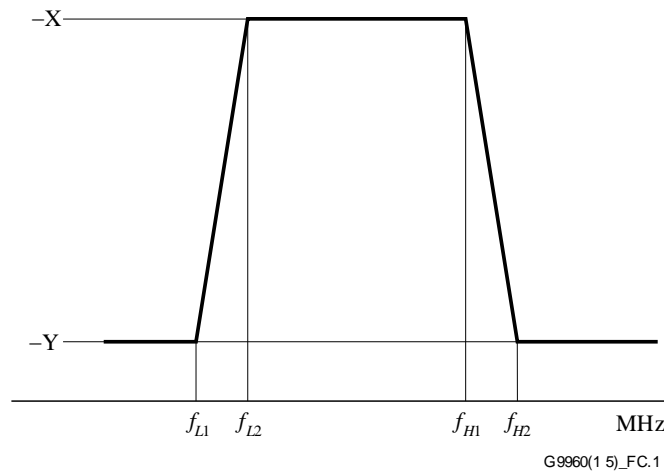

Figure C.1 – Limit PSD mask over RF coax for transceivers used between 770 MHz and 1032 MHz

The values of frequency spectrum parameters for coax are presented in Table C.2. It is assumed that interim points between those defined in Figure C.1 are obtained by linear interpolation (dB over linear frequency scale).

Table C.2 – Parameters of limit PSD mask over RF coax for transceivers used between 770 MHz and 1032 MHz

Parameters	Frequency (MHz)	PSD (dBm/Hz) (Note)	Note/Description
$F_C - f_{L1}$	130	-Y	
$F_C - f_{L2}$	100	-X	
F_C	$M * 25$ MHz	-X	
$f_{H1} - F_C$	100	-X	
$f_{H2} - F_C$	132	-Y	

NOTE – $M = 36$ for 200 MHz, see Note 5 for other bandplans.

NOTE 1 – In cases where additional spectrum shaping is used, as described in clause 5.2 of [ITU-T G.9964], the transmit PSD mask can be reduced in the relevant parts of this spectrum by switching subcarriers off or reducing their transmit power.

NOTE 2 – More than one channel may be allocated within the limit PSD mask in Table C.2. In this case, out-of-band PSD of each channel should not interfere with other channels. The detailed requirements are for further study.

NOTE 3 – Out-of-band spurious signals at the output of an ITU-T G.9960 node operating over coax in RF mode are supposed to meet the limit PSD mask defined in Table C.2. The limit for total power of out-of-band spurious signals is for further study. The requirements for in-band spurious signals are for further study.

NOTE 4 – Specification of guard bands are for further study.

NOTE 5 – Parameters of limit PSD mask over RF coax for bandplans 50 MHz and 100 MHz for Annex C should be the same as those in clause 6.3 of [ITU-T G.9964] PSD mask specifications with an arbitrary integer number of M , but not to exceed the PSD mask for Table C.2.

NOTE 6 – Values for X and Y are for further study.

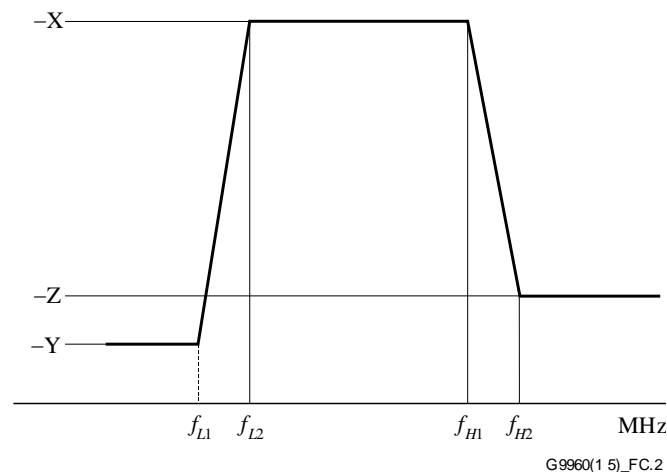

Figure C.2 – Limit PSD mask over RF coax for transceivers used above 2070 MHz

**Table C.3 – Parameters of limit PSD mask over RF coax
for transceivers used above 2070 MHz**

Parameters	Frequency (MHz)	PSD (dBm/Hz) (Note)	Note/Description
f_{L1}	2070	-Y	
f_{L2}	2200	-X	
F_C	$M*25$ MHz	-X	
f_{H1}	2850	-X	
f_{H2}	2950	-Z	
NOTE – $M = 92$ or 110 for 200 MHz-RF. See Note 11 for other bandplans.			

NOTE 7 – In cases where additional spectrum shaping is used, as described in clause 5.2 of [\[ITU-T G.9964\]](#), the transmit PSD mask can be reduced in the relevant parts of this spectrum by switching subcarriers off or reducing their transmit power.

NOTE 8 – More than one channel may be allocated within the limit PSD mask in Table C.3. In this case, the out-of-band PSD of each channel should not interfere with other channels. The detailed requirements are for further study.

NOTE 9 – Out-of-band spurious signals at the output of ITU-T G.9960 node operating over coax in RF mode are supposed to meet the limit PSD mask defined in Table C.3. The limit for the total power of out-of-band spurious signals is for further study. The requirements for in-band spurious signals are for further study.

NOTE 10 – Specification of guard bands are for further study.

NOTE 11 – Parameters of limit PSD mask over RF coax for bandplans 50 MHz and 100 MHz for Annex C should be the same as those in clause 6.3 of [\[ITU-T G.9964\]](#) PSD mask specifications with arbitrary integer number of M , but not to exceed the PSD mask for Table C.3.

NOTE 12 – Values X, Y and Z are for further study.

C.2.3.4 Transmitter EVM requirements for coax RF

The EVM requirements are for further study.

Annex D

(This annex has been intentionally left blank.)

Annex E

(This annex has been intentionally left blank.)

Annex F

Usage of ITU-T G.9960 for optical transmission

(This annex forms an integral part of this Recommendation.)

F.1 Scope

This annex describes the way to apply the ITU-T G.9960 system for optical transmission.

F.2 Media dependent specification

F.2.1 Physical layer specification over SI-POF (Step-index polymer/plastic optical fibres)

The core parameters for an LED-based optical transmitter should be as described in Table F.1.

Table F.1– Parameters for a LED-based optical transmitter

Parameter	Value/Unit
Centre wavelength	640-660 nm
Maximum spectral width	30 nm
Maximum optical transmit power	0 dBm
Minimum optical bandwidth (–3 dB point)	100 MHz for bandplan 100 MHz-SB and 200 MHz for bandplan 200 MHz-SB

The core parameters for the optical receiver should be as shown in Table F.2.

Table F.2 – Parameters for the optical receiver

Parameter	Value/Unit
Wavelength	640-660 nm
Minimum receiver sensitivity	–20 dBm

NOTE 1 – Typically a cable will include one or two SI-POF. It is recommended that the cable will be compliant with categories A4a.1 and/or A4a.2 according to [b-IEC 60793-2-40].

NOTE 2 – For the cable connection to the optical receiver and the optical transmitter, a connector-less connection should be preferred. If connectors are used it is recommended that they will comply to standards such as SMI [b-IEC 61754-21] or SC/RJ [b-IEC 61754-24].

F.2.2 Bandplan

Table F.3 shows the valid OFDM control parameters for various bandplans defined for SI-POF:

Table F.3 – OFDM parameters for SI-POF

Domain type	SI-POF baseband	SI-POF baseband
Bandplan name	100 MHz – SB	200 MHz – SB
N	512	1024
F_{SC}	195.3125 kHz	195.3125 kHz
N_{GI}	$N/32 \times k$ for $k=1, \dots, 8$ samples @ 100 Msamples/s	$N/32 \times k$ for $k=1, \dots, 8$ samples @ 200 Msamples/s
N_{GI-HD}	$N/4=128$ samples @ 100 Msamples/s	$N/4=256$ samples @ 200 Msamples/s
N_{GI-DF}	$N/4=128$ samples @ 100 Msamples/s	$N/4=256$ samples @ 200 Msamples/s
β	$N/32=16$ samples @ 100 Msamples/s	32
F_{US}	50 MHz	100 MHz
F_{UC}	0 MHz	0 MHz
Subcarrier indexing rule	Rule #1	Rule #1
NOTE – See clause 7.1.4.1 for more details on subcarrier indexing rules.		

The $\text{const_scrambler_sequence}[i] = (s1,s2)$ denotes the LFSR output for the subcarrier index $8(i-1)$ (clause 7.1.4.3.3). That is, $\text{const_scrambler_sequence}[1] = (0,1)$ corresponds to the subcarrier index 0, $\text{const_scrambler_sequence}[2] = (0,0)$ to the subcarrier index 8, etc.

G.6.2 Preamble generation test vector 2

Using the test vector from clause G.6.1, the normalized constellation scrambler output corresponding to the first section of the preamble assuming 25 MHz-PB bandplan shall be

$\text{pre_cscram_output}[1:128] = \{0, 0, 0, 0, 0, 0, 0, 0, 0, 0, 0, j, -1, j, j, -1, -j, j, 1, j, -j, j, 1, 1, j, -j, -1, j, -j, -j, 1, -1, -1, j, -j, 1, j, -j, 1, -1, -j, j, -1, 1, 1, -j, -1, 1, j, -j, -j, j, 1, -j, j, -1, -1, -1, -1, -1, -1, 1, 1, 1, 1, -1, -j, 1, 1, -1, -1, -1, 1, 1, -j, 1, -1, -j, -j, j, -1, 1, j, 1, 1, 1, 1, 1, -j, -1, 1, 1, -j, -j, j, j, -j, -1, 1, -j, -1, -1, -j, -1, -j, -j, -j, 1, -1, -j, -1, -j, 1, 1, 1, -1, 1, 1, -1, -1, j, -j, -1, -j, -j, 1, 1, 1\}$

The first non-zero output $\text{pre_cscram_output}[11] = j$ corresponds to the subcarrier index 80, $\text{pre_cscram_output}[12] = -1$ corresponds to the subcarrier index 88, etc. The PMSC set is given in clause 7.2.2.4. No RMSC set is assumed.

Appendix I

Examples of home network topologies

(This appendix does not form an integral part of this Recommendation.)

An example of a home network containing a single domain is shown in Figure I.1 where a single domain master coordinates nodes of the domain (i.e., assigns bandwidth resources and priority). In this example, the domain is bridged to the access network via node D (it is also a domain master) that is assumed to be part of the residential gateway. In PM, nodes A, B, C and D communicate directly with each other. In CM, one of the nodes is assigned as DAP (node D in this example), and all nodes can communicate with each other only via this node. In UM, each of the nodes A-D can communicate directly with each other or indirectly, via other nodes operating as relay nodes. In this example, node D (domain master) serves as a relay node, while other nodes use either P2P or node D as a relay if required.

While in either PM, CM or UM, nodes A-D can transmit under limitation of bandwidth resources and priorities assigned by the domain master.

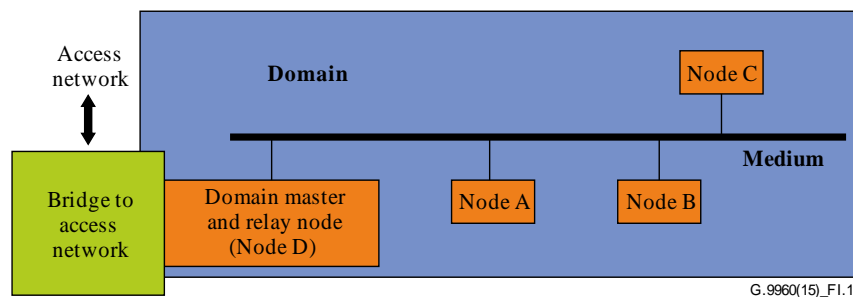
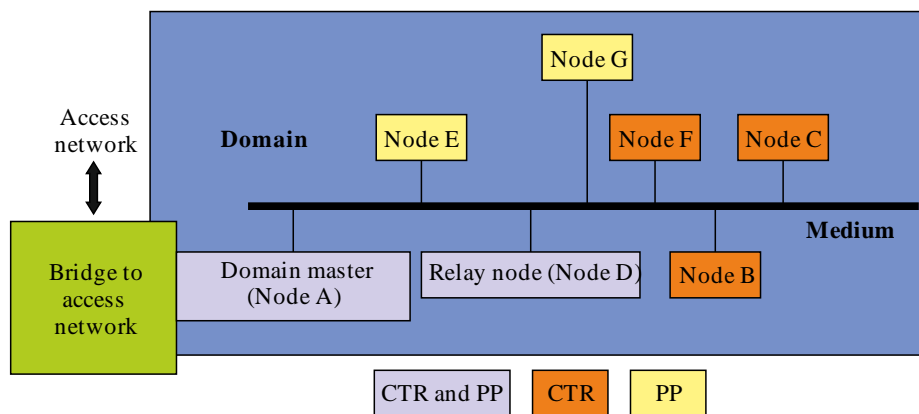

Figure I.1 – Example of a home network containing a single domain

An example of a home network containing a single domain that operates in UM using both P2P and REL is depicted in Figure I.2. The subset of nodes that use REL includes nodes B, C, D and F, where node D operates as a relay node for this group of nodes. All other nodes can communicate directly (i.e., using P2P) or via a relay node (i.e., using REL). A single domain master (in this case node A) coordinates the nodes of the domain. The domain is bridged to the access network via node A, which is assumed to be part of the residential gateway. While using either P2P or REL, nodes A to G can transmit under the limitation of bandwidth resources and priorities assigned by the domain master. Frames from nodes B, C and F addressed to nodes outside the domain are sent to node A via relay node D; node A is connected to the inter-domain bridge. Frames from nodes D, E and G addressed to nodes outside the domain are sent to node A directly.



G.9960(15)_F1.2

Figure I.2 – Example of a home network containing a single domain operating in UM (using a combination of P2P and REL)

An example of a home network containing three domains with corresponding domain masters established on two different media is depicted in Figure I.3. Nodes of domain 1 and of domain 3 operate over the same medium (medium 1). In this example, it is assumed that domain 1 and domain 3 operate in different spectral bands. Those two domains are bridged via an inter-domain bridge (on layer 2 or layer 3). Domain 2 operates on a different medium (denoted as medium 2). Domains 1 and 2 are bridged to the access network. In Figure I.3 it is assumed that the domain master of domain 2 and node A of domain 1 are parts of the residential gateway. Domains 1 and 3 are connected by an inter-domain bridge. Each of the three domains can operate in either PM, UM or CM, independently of the operational mode used by other domains.

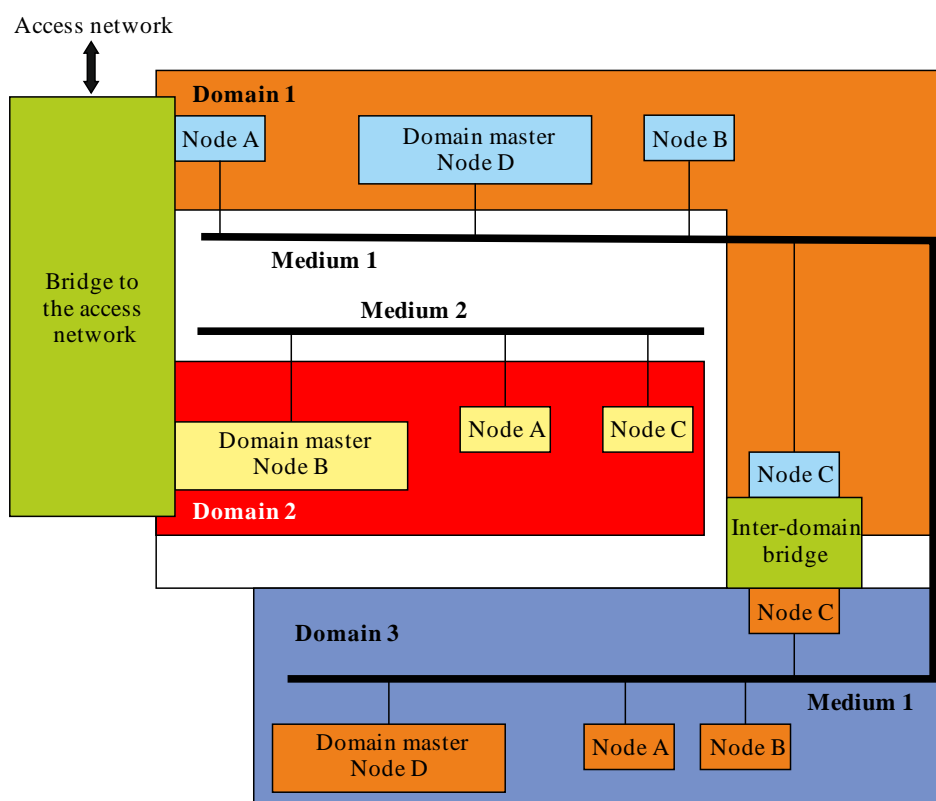

G.9960(15)_F1.3

Figure I.3 – Example of a home network comprising three domains

An example of a home network connected to an alien domain is shown in Figure I.4. The example shows a home network containing two domains (domains 1 and 2) with corresponding domain masters established on two different media, bridged via an inter-domain bridge (layer 2 or layer 3) to the alien domain. The alien domain is established on the same medium as domain 1. Nodes of domain 1 and of domain 2 in Figure I.4 operate over different media, while nodes A1-A3, which are alien nodes, share the same medium with domain 1. The domain master of domain 1 considers the alien domain as another AE connected to the corresponding node of domain 1. Operation of this alien domain and its interconnection with an ITU-T G.9960 home network is outside of the scope of this Recommendation.

In this example, node A of domain 1 is bridged to the access network. This bridge is usually a part of the residential gateway.

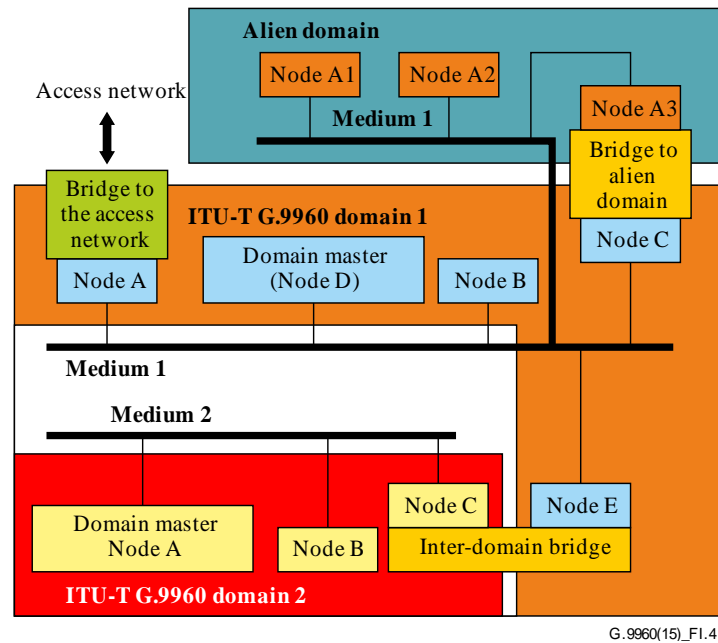
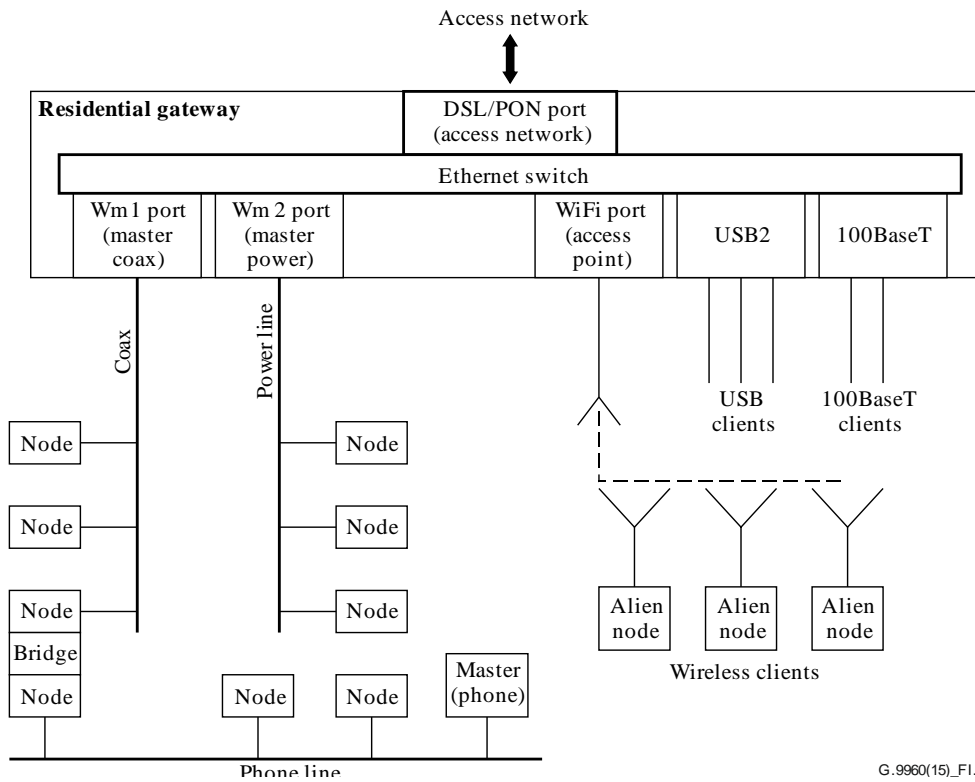

Figure I.4 – Example of an ITU-T G.9960 domain sharing a medium with an alien domain

An example of a home network associated with residential broadband access is presented in Figure I.5. In the example, the home network includes three domains established over coax, telephone and power-line wiring. Alien domains are established by the residential gateway and may include WLAN IEEE 802.11, USB2, and IEEE 802.3 (Ethernet). The RG serves as a bridge allowing communication with alien domains (e.g., 802.11) and with an access network (e.g., PON or DSL).

Each node in Figure I.5 is configured for the medium it is connected to. It can communicate with any other node of the same domain using either P2P or REL. Communication between nodes of different domains (e.g., between coax and telephone line in Figure I.5) is via inter-domain bridges or via the RG. Communication with alien nodes and with the access network is via bridges, which are a part of the RG.



G.9960(15)_FI.5

Figure I.5 – Example of a home network supporting residential broadband access

Appendix II

Spectral usage

(This appendix does not form an integral part of this Recommendation.)

II.1 Scope

This appendix describes information on spectral usage on each medium (coax cable, telephone line and power line).

II.2 Spectral usage in Japan

II.2.1 Frequency allocation for coax

There are mainly three types of services which are mapped to in-home coax medium:

- terrestrial broadcasting
- satellite broadcasting
- CATV services.

The frequency allocations for all cases are shown in this clause.

It should be noted that a coaxial home network connected to a cable access network should not interfere with services offered by the cable television operator to customers. The general use of the frequency by the cable television operator is 5 to 770 MHz.

II.2.1.1 Terrestrial broadcast signal mapped to coax cable

Table II.1 shows the frequency allocation for terrestrial TV broadcasting mapped to coax cable. Currently, both analogue TV broadcasting (VHF/UHF) and digital TV broadcasting (UHF) are in service [b-Spectrum]. But analogue TV broadcasting services were planned to be discontinued on 24 July 2011 [b-Schedule] [b-Announcement] and non-TV broadcasting and other telecommunications were planned to use these bands after that. ITU-T G.9960 is one of the candidate services for empty bands if available, but this is for further study.

Table II.1 – Frequency allocation for terrestrial broadcast signals mapped to a coax cable

Frequency (MHz) (Note)	Remarks
90 to 108	Used for analogue TV broadcasting until 24 July 2011 The use after 25 July 2011 is not determined at the time of publication Retransmission of terrestrial digital TV broadcasting (OFDM)
108 to 170	Retransmission of terrestrial digital TV broadcasting (OFDM)
170 to 222	Used for analogue TV broadcasting until 24 July 2011 The use after 25 July 2011 is not determined at the time of publication Retransmission of terrestrial digital TV broadcasting (OFDM)
222 to 470	Retransmission of terrestrial digital TV broadcasting (OFDM)
470 to 710	Used for analogue TV broadcasting until 24 July 2011 Used for digital TV broadcasting Retransmission of terrestrial digital TV broadcasting (OFDM)

Table II.1 – Frequency allocation for terrestrial broadcast signals mapped to a coax cable

Frequency (MHz) (Note)	Remarks
710 to 770	Used for TV broadcasting until 24 July 2012 The use after 25 July 2012 is not determined at the time of publication Retransmission of terrestrial digital TV broadcasting (OFDM)
NOTE – Frequency band usage for ITU-T G.9960 including guard band is for further study.	

II.2.1.2 Broadcast satellite (BS) and communication satellite (CS) signal mapped to coax cable

Satellite broadcasting (BS and CS) using around 12 GHz of frequency [b-Spectrum] are down-converted to intermediate frequency (BS-IF/CS-IF) at an antenna before transmission to a coax cable. The BS and CS need dedicated receiver antennas and there are various cases to use in-home coax cables depending on locations of antennas and connection points to an in-home coax system. Basically, BS-IF/CS-IF signals come from an antenna or CATV. Table II.2 shows satellite broadcast signals mapped to a coax cable.

Table II.2 – Frequency allocation for satellite broadcast signals mapped to a coax cable

Satellite broadcasting services (Note)	BS-IF/CS-IF (MHz)	Remarks
BS	1035.95-1331.50	BS-IF transmission
110° CS	1596-2070	CS-IF transmission
JC SAT-3,4	968-2055	CS-IF transmission
Superbird C	1020-2040	CS-IF transmission
NOTE – ITU-T G.9960 frequency band usage including guard band is for further study.		

II.2.1.3 CATV services on coax cable

Table II.3 shows the frequency allocation of other services [b-CTBL][b-STD-013]. Since frequencies below 770 MHz are currently used for the various services listed in Table II.3, their usage for other services such as ITU-T G.9960 is for further study.

Table II.3 – Frequency allocation of other services on coax cable

Frequency (MHz)	Usage	Remarks
5 to 60 (Note 1)	<ul style="list-style-type: none"> Upstream CATV signal (cable Internet signal, VoIP, VOD, relay broadcast, pilot signal, etc.) 	<ul style="list-style-type: none"> Being used for cable modem up-stream signals [b-ITU-T J.112] [b-ITU-T J.122] [b-ITU-T J.222.1] Being used for control signals between cable modem and cable modem termination
70 to 76 (Note 1)	<ul style="list-style-type: none"> Downstream pilot signal, analogue HT (home terminal) control signal, monitoring signal of amplifier 	<ul style="list-style-type: none"> Being used for cable modem up-stream signals [b-ITU-T J.112] [b-ITU-T J.122] [b-ITU-T J.222.1]

Table II.3 – Frequency allocation of other services on coax cable

Frequency (MHz)	Usage	Remarks
76 to 90 (Note 1)	<ul style="list-style-type: none"> Retransmission of radio broadcasting on cable (FM radio signal) 	<ul style="list-style-type: none"> Being used for cable modem up-stream signals [b-ITU-T J.222.1]
90 to 770 (Note 1)	<ul style="list-style-type: none"> Analogue cable broadcasting (NTSC-VSB) Digital cable broadcasting (64/256 QAM) Retransmission of terrestrial analogue TV broadcasting (NTSC-VSB) Retransmission of terrestrial digital TV broadcasting (OFDM) Downstream cable Internet signal, VoIP, VOD control signal, etc. 	<ul style="list-style-type: none"> Covered by regulation [b-CTBL]
770 to 1035 (Note 2)	<ul style="list-style-type: none"> Alien home network services 	
1035 to 2070 (Note 1)	<ul style="list-style-type: none"> BS-IF/CS-IF retransmission 	
>2070 (Note 2)	<ul style="list-style-type: none"> Currently not in use at the time of publication 	
NOTE 1 – ITU-T G.9960 frequency band usage including guard band is for further study.		
NOTE 2 – Candidate frequency band for ITU-T G.9960 including guard band.		

II.2.2 Frequency allocation for telephone line

For further study.

II.2.3 Frequency allocation for power line

For further study.

Appendix III

Priority mapping

(This appendix does not form an integral part of this Recommendation)

The priority mapping recommended by [IEEE 802.1D] (clause 7.7.3) is presented in Table III.1.

Table III.1 – Recommended flow priority to priority queue mappings according to [IEEE 802.1D]

		Number of available traffic classes							
		1	2	3	4	5	6	7	8
User priority	0 (default)	0	0	0	1	1	1	1	2
	1	0	0	0	0	0	0	0	0
	2	0	0	0	0	0	0	0	1
	3	0	0	0	1	1	2	2	3
	4	0	1	1	2	2	3	3	4
	5	0	1	1	2	3	4	4	5
	6	0	1	2	3	4	5	5	6
	7	0	1	2	3	4	5	6	7

Appendix IV

Smart grid applications based on ITU-T G.9960

(This appendix does not form an integral part of this Recommendation.)

IV.1 Introduction

Smart grid is a term used for an advanced electricity delivery system that is integrated with modern digital and information technology to provide improved reliability, security, efficiency, and ultimately lower cost of the utility services to the user.

This appendix describes how smart grid applications and devices are accommodated by the ITU-T G.9960 architecture. The architecture incorporates nodes that operate as part of a smart grid home area network (HAN), and describes mechanisms to connect the HAN to a service provider access network.

In this appendix, ITU-T G.9960-compliant smart grid devices that operate in the HAN are called ITU-T G.9960 smart grid HAN (SGH) nodes. Other devices (ITU-T G.9960-compliant or not) that operate in the service provider access network are called smart grid access (SGA) devices.

To help meet the complexity and energy consumption requirements for smart grid applications, SGH nodes may be based on low-complexity profiles. Nodes of low-complexity profiles are fully interoperable with other nodes operating in the same domain.

IV.2 SGH devices

Nodes may be embedded into devices that participate in the smart grid HAN (SGH devices). Typically, these are consumer-owned appliances that may require external control or devices that control the use of energy by other devices. Examples of devices in this category are:

- in-home smart meters
- energy services interface (ESI) devices and gateways to the SG access network
- in-home displays (IHD) and thermostats
- heating or air-conditioning appliances
- plug-in electric vehicles (PEV) and electric vehicle supply equipment (EVSE)
- washing machines, dryers and dishwashers.

NOTE – Some of these devices can be located outside the home, for example, in a detached building.

Besides, these SGH devices will be able to provide a variety of smart grid applications related to data processing and data exchange. Examples include:

- collection of information on energy consumption and distributing this information to consumers and service providers;
- adapting energy consumption to time-of-day fluctuations in energy billing rules;
- supporting of automatic demand response programmes;
- flexible control of appliances to reduce power consumption when not in use.

IV.3 Architecture

The SGH nodes are connected to the ITU-T G.9960 network based on standard architecture (see Figure IV.1). They can be connected to any of the wireline media types available at the customer premises (power line, telephone line, coax, or CAT 5 cables); interconnection between SGH nodes connected to different media is through the corresponding IDBs.

The bit rate and the QoS for communications between SGH nodes are set to meet the smart grid application requirements. The scheduled inactivity mechanism allows further reduction of the power consumption of SGH nodes.

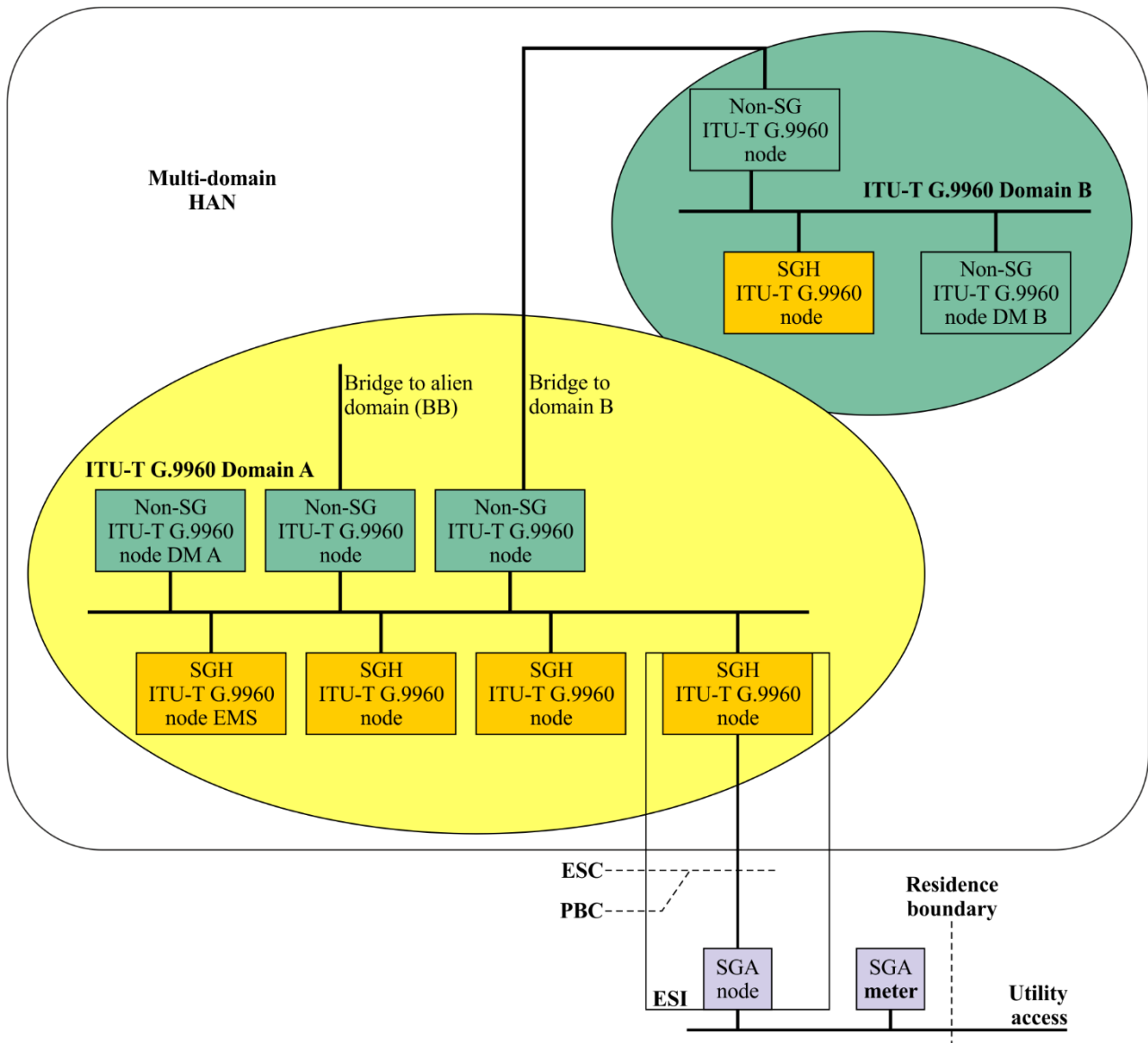

NOTE 1 – In some implementations, the meter may not be part of the ESI.

NOTE 2 – The SGH nodes and non-SG nodes relate to smart grid and non-smart grid applications, respectively, both complying with this Recommendation.

G.9960(15)_FIV.1

Figure IV.1 – Illustration of smart grid HAN implementation based on ITU-T G.9960

The HAN (comprising SGH nodes and regular non-SG nodes, connected to domains A and B) interfaces with the service provider SG access network via the energy services interface (ESI) in order to implement end-to-end smart grid applications between the SGH devices and the SG access network devices, external to the home. The HAN can be connected to the SG service provider via any generic broadband access network using various access technologies, which might be a power-line communication network, wireline network (e.g., DSL), wireless network, or other type of access. If smart grid applications are delivered over power lines, SGA devices will coexist with HAN devices on the same power-line wires using generic coexistence mechanisms and communicate with HAN devices via the ESI.

The ESI provides a physical connection to the in-home medium (via SGH node), a physical or logical connection to access network (SGA node), and a logical interface (i.e., a bridge, gateway, or proxy) between the service provider and SG devices of the HAN. The ESI is expected to facilitate at least two service channels (at OSI Layer L3 and higher) between the access network and the HAN:

- energy services channel (ESC)
- public broadcast channel (PBC).

The ESC is required to be two-way secure: the SGH devices registered with the utility or the service provider communicate with each other and with the service provider (via ESI) over the ESC that operates on OSI Layer L3 and higher. The PBC is used to supply the customer with public data of a general nature related to SG applications (e.g., per-hour pricing, instant discounts, events, etc.). The PBC may be insecure. Besides these two channels, other channels may also be established via ESI, such as broadband channel for Internet connections – not shown in Figure IV.1.

The energy management system (EMS) is an SG device connected to the HAN that manages remote-controllable SGH devices, such as heaters, pool water pumps, air conditioners, and others. The presence of EMS is optional.

For security purposes, the SGH nodes within a HAN are logically separated from non-SGH HAN nodes by secure high-layer protocols running over the ESC: both for registration of SGH devices with the utility, and for communications between SGH devices and with the utility. These ESC protocols are on the top of the security mechanisms, and hence allow secure SG communications with a HAN independently of its topology and specifics of particular customer installation. If all SGH devices are connected to the same medium, security can be further enhanced by separating of all registered SGH nodes into a domain whose security settings are controlled by the utility via ESI.

In some implementations, smart grid services can also be delivered through the broadband access (BB) or through another alien domain (e.g., a wireless SGA domain).

IV.4 Interconnection with narrowband networking technologies

Narrowband networking technologies used for smart grid applications can operate with ITU-T G.9960 SGH in the same residence. These are wireless technologies and the narrowband power line technologies are usually referred to as PLC technologies. PLC technologies operate in the frequency spectrum below 500 kHz, and do not overlap with the spectrum used by ITU-T G.9960 nodes (above 2 MHz). Thus, both technologies can coexist on the same medium with insignificant impact on each other.

Interconnection between ITU-T G.9960 SGH devices and narrowband network devices is based on the generic ITU-T G.9960 architecture, Figure 5-1, and done through L3 (network layer) bridging. The gateway device includes an ITU-T G.9960 port towards an ITU-T G.9960 domain and a narrowband network port (PLC or wireless) towards the narrowband network. In some applications, it is convenient that the gateway between the narrowband technology and ITU-T G.9960 is the "access point" of the narrowband network.

An ITU-T G.9960 SGH node bridged to the legacy network will consider it as an alien network, Figure IV.2.

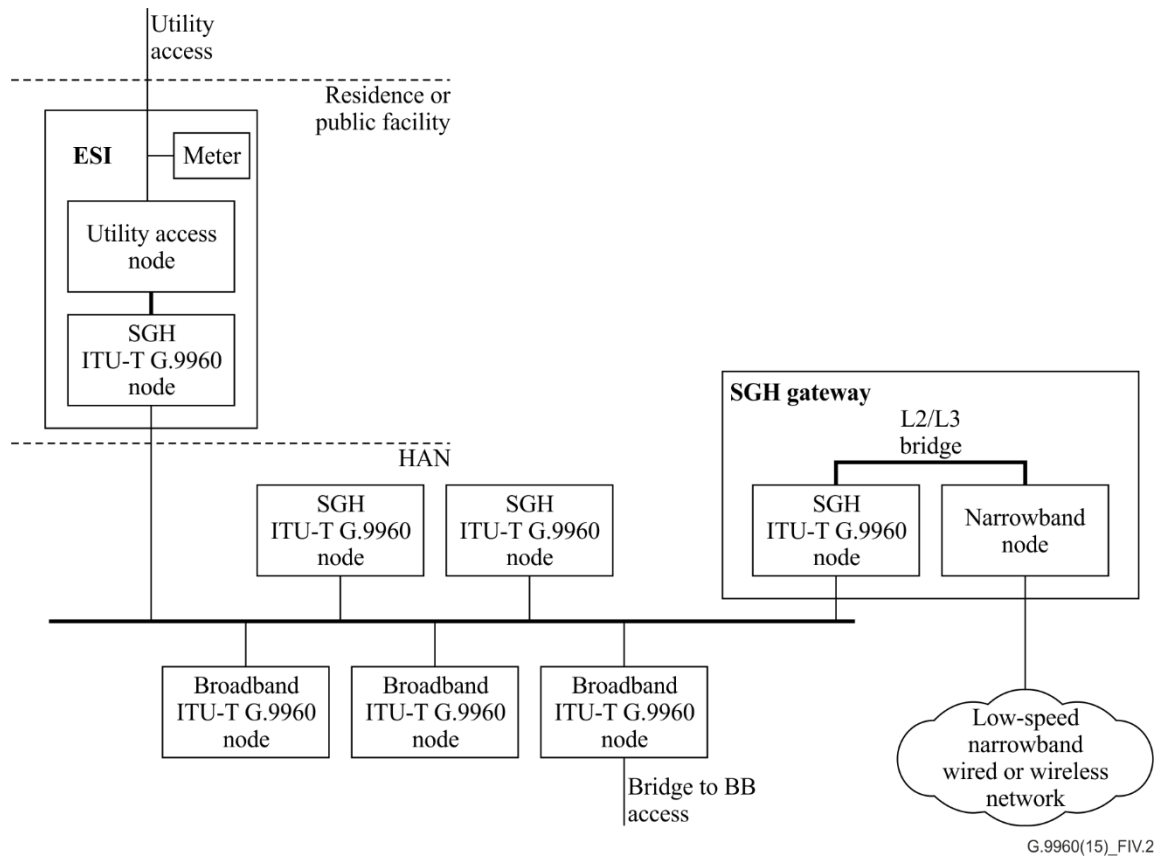

G.9960(15)_FIV.2

Figure IV.2 – Interconnection between ITU-T G.9960 SGH and an SG narrowband network

IV.5 Authorized admission and authentication

For most SG applications, SG devices shall be registered with the utility (i.e., only devices approved by the service providing utility may be admitted). For authorized admission and authentication, a trusted channel is established between the utility and the HAN via the ESI.

The ITU-T G.9960 admission procedure allows two types of authorized admission of the devices:

- a preset admission, when a new device is preprogrammed by the user/utility/installer with the domain name of the SG domain it is intended to join;
- a blind admission, when the domain name cannot be preprogrammed by the user (device with no user interface).

In cases of preset admission, the SG device registers with the domain master by the domain name. For blind admission, the user/installer inserts into the domain master's information base the device-unique registration code provided by the manufacturer (usually, the device's MAC address). Alternatively, the utility communicates the registration code of the device to the domain master via the ESI over the trusted channel. The latter provides a pure plug-and-play admission.

For authentication, each device shall be programmed with a password that is known to the utility. The password can be inserted by the user/installer or hardcoded by the manufacturer. After admission to the domain, the device sends its authentication request to the SC. To authenticate the device, the SC searches for the actual password of the device using the device's MAC address; if the SC cannot find the password in its database, it requests the password from the utility via the trusted channel established between the HAN and the utility. If no password is identified, the SC denies the authentication and forces the device to resign from the domain. If the password is identified, the utility passes the password to the SC via the ESI. Furthermore, a standard authentication procedure between the device and the SC is performed. Upon successful authentication, the device may apply for encryption keys to communicate with the ESI or any other node of the domain it is allowed to communicate with.

Appendix V

Electric vehicle applications based on ITU-T G.9960

(This appendix does not form an integral part of this Recommendation.)

V.1 Introduction

This appendix describes how ITU-T G.9960 nodes can be used for applications related to plug-in electric vehicles (PEVs), including networking nodes installed into the electric vehicle supply equipment (EVSE) and nodes installed into the PEV, designated here as "EV nodes". These nodes, both in the EVSE and attached EV(s), form an electric vehicle charging facility (EVCF).

To reduce the complexity and energy consumption of ITU-T G.9960 nodes in an EVCF, these nodes may be implemented using ITU-T G.9960 low-complexity profiles. Low-complexity profile nodes are fully interoperable with other ITU-T G.9960 nodes operating in the same domain.

A simplified diagram of an EVCF including EVSE and an attached EV, showing the primary external connections, is presented in Figure V.1.

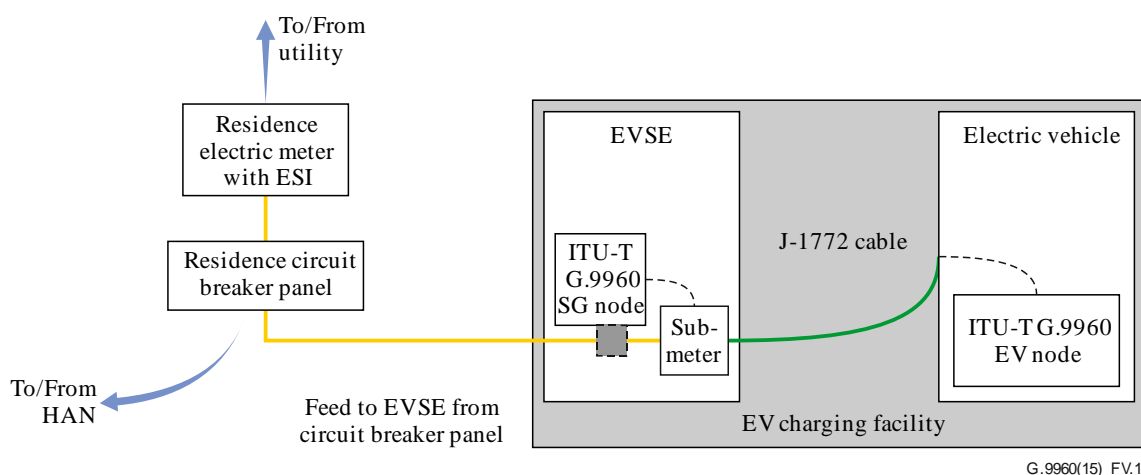

Figure V.1 – EVCF with EVSE and one attached EV showing external links

V.2 EVSE and EV devices

ITU-T G.9960 nodes embedded into EVs and EVSEs perform the following common functions:

- establish a link between EVSE and EV nodes in a period that does not exceed five seconds;
NOTE 1 – Establishing a link includes at least registration and authentication of the EVSE node, registration and authentication of the EV node by using the EVSE node as a proxy, and getting authorization from the utility for the charging activity.
- operate in a mode where the EVSE node operates as a proxy for the EV node of the connected PEV, i.e., all the communications between the EV node and the outside world are exclusively through the EVSE node.
- The data exchanged between EVSE and EV nodes can be of three types: recharging/discharging management, EV maintenance, and multimedia data. The first type may only require low throughput, while the second and third types require relatively high data throughput (with a predominant amount downstream to the EV). Some EVs may only require the first two types of data.

The EVSE device provides the following communications:

- with the HAN domain master (or ESI, if ESI is the domain master in the residence) and the associated security controller;

- with HAN nodes, directly or via an IDB if the HAN uses non-ITU-T G.9960 technology. The EVSE node should coexist with the HAN if it is unable to communicate with it directly;
- with the ESI of the residence, directly or via an IDB if the ESI uses non-ITU-T G.9960 technology. The EVSE node should coexist with the ESI if it is unable to communicate with it directly;

NOTE 2 – In the event that an ESI is not present, the EVSE could communicate with the utility's servers through the broadband link that the HAN is connected to.

- with the utility, via the ESI or over the HAN's broadband link (if present and utility allowed). These communications provide the EVSE with information such as billing rates, the maximum amount of current flow allowed, the allowed time for charging, the authorization of the specific vehicle to charge at this specific EVSE, and the meter readings related to the change;
- with an EV node of any PEV attached to the EVSE's J-1772 cable(s). The EVSE node acts as a proxy for the EV node into the HAN and the ESI.

An example of a connection between an EVSE and an EV node is presented in Figure V.2. The EVSE controller detects a J-1772 connection to an EV (via sense lead) and triggers EVSE node connection to the EV, as well as triggering electricity to flow over the cable once all authorization is completed. The EV controller manages the charging of the batteries in the EV and turns the EV node on and off depending on sense lead status or the option that the EV controller determines the EV is going to charge through a regular power outlet.

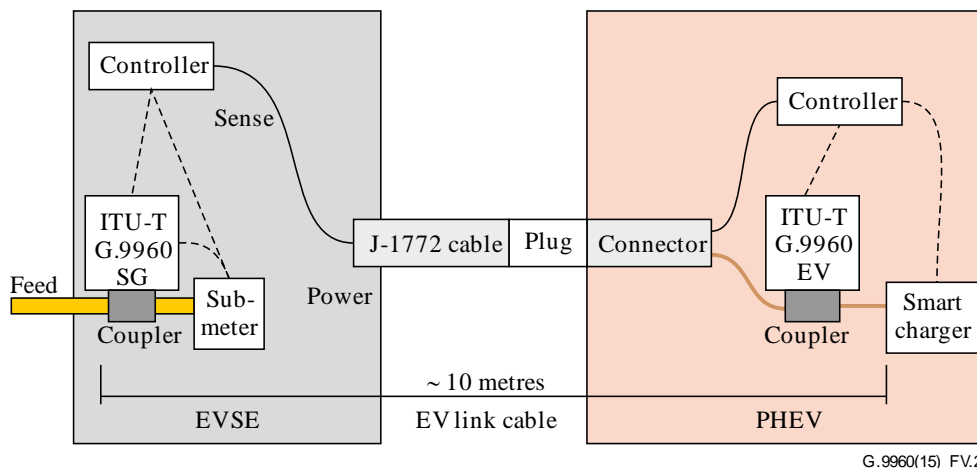

Figure V.2 – Simple EVSE to EV link using a J-1772 cable

For residential garages, it is anticipated that the EVSE will communicate with an estimated two vehicles simultaneously, over individual J-1772 cables from the EVSE, respectively. For deployment in public parking areas, it is envisioned that an EVSE will have the ability to handle up to four EVs concurrently, see Figure V.3. In both cases, the EVSE controller, with assistance of the EVSE node, will identify which EV is associated with which metre and J-1772 cable.

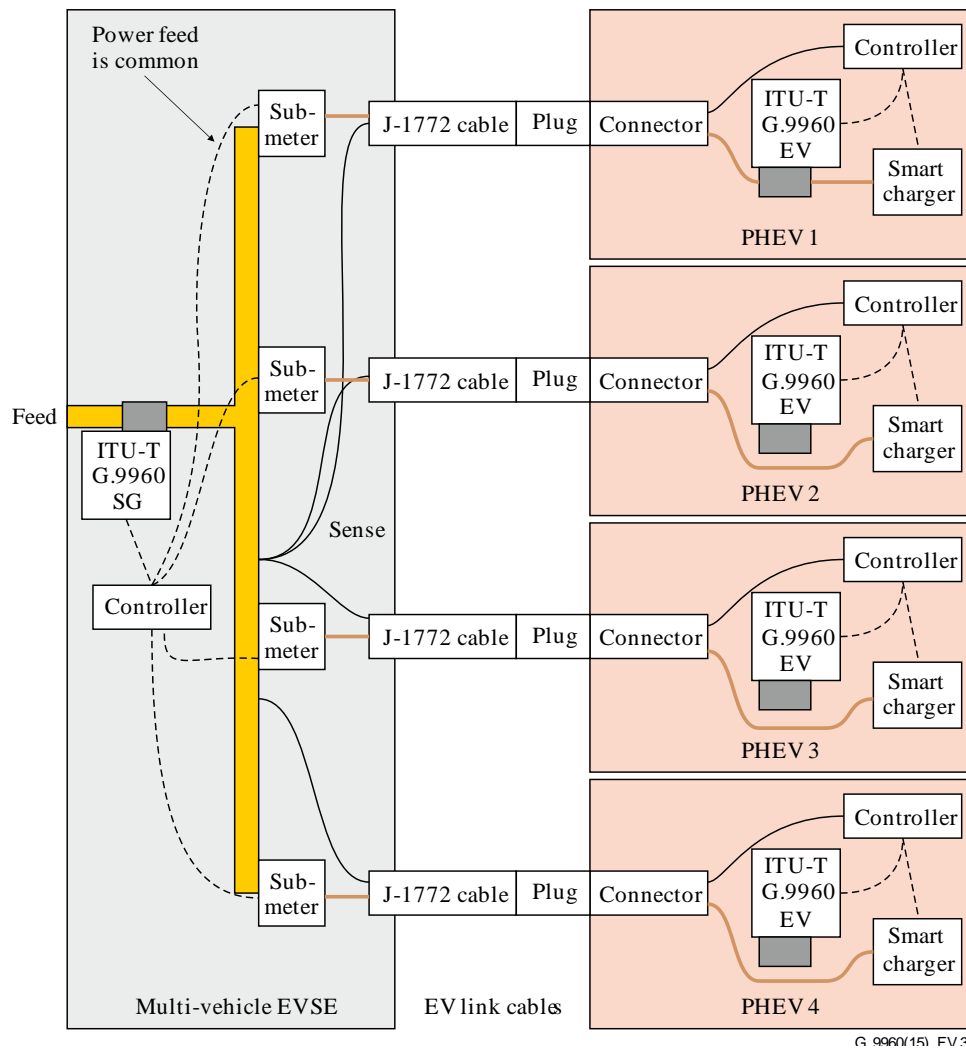

Figure V.3 – EVSE attached to four EVs

Typically, the vehicle needs to communicate with the far-end system (utility) for charging authorization and with other services using the EVSE as a proxy. The link between the EV and corresponding EVSE in the EVCF is secure, with a point-to-point key established using the regular ITU-T G.9960 AKM procedure.

The EV node may have these characteristics:

- Communicate to the HAN or ESI through the EVSE node, which may serve as a proxy for the EV node.
- EV node transmission power levels are controlled to prevent unnecessary EMI and unintended association between the EV of different J-1772 cables, using the standard ITU-T G.9960 power ceiling set-up procedure where lower power levels are established and maintained as default.
- The EV nodes are not expected to act as proxies, as relays, or as domain masters, and not expected to maintain large topology tables.
- The EV node transmission data rate is not expected to exceed 5 Mbit/s.
- The EV node receive data rate is not expected to exceed 20 Mbit/s.
- The EV node is not expected to have special requirement for low latency of data processing.

Using one or more network nodes besides the EV node is for further study. In the example presented in Figure V.4, the plug-in hybrid electric vehicle (PHEV) nodes may be standard low complexity ITU-T G.9960 SG nodes and able to communicate with one another.

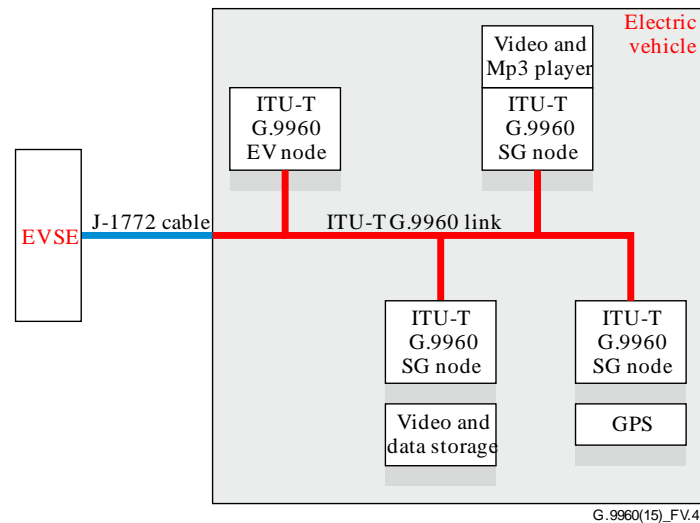

Figure V.4 – Example of multiple nodes within an EV

A typical distance between the EV node and the EVSE node is 10 m, although this distance could be longer in a public parking area or in a multi-car garage.

V.3 Overall network architecture

The EVSE nodes are connected to the HAN and the ESI based on the standard ITU-T G.9960 architecture (see Figure 5-1). The usual application uses a power line as a communication medium, see Figure V.5, although any other in-home wired medium is possible with ITU-T G.9960.

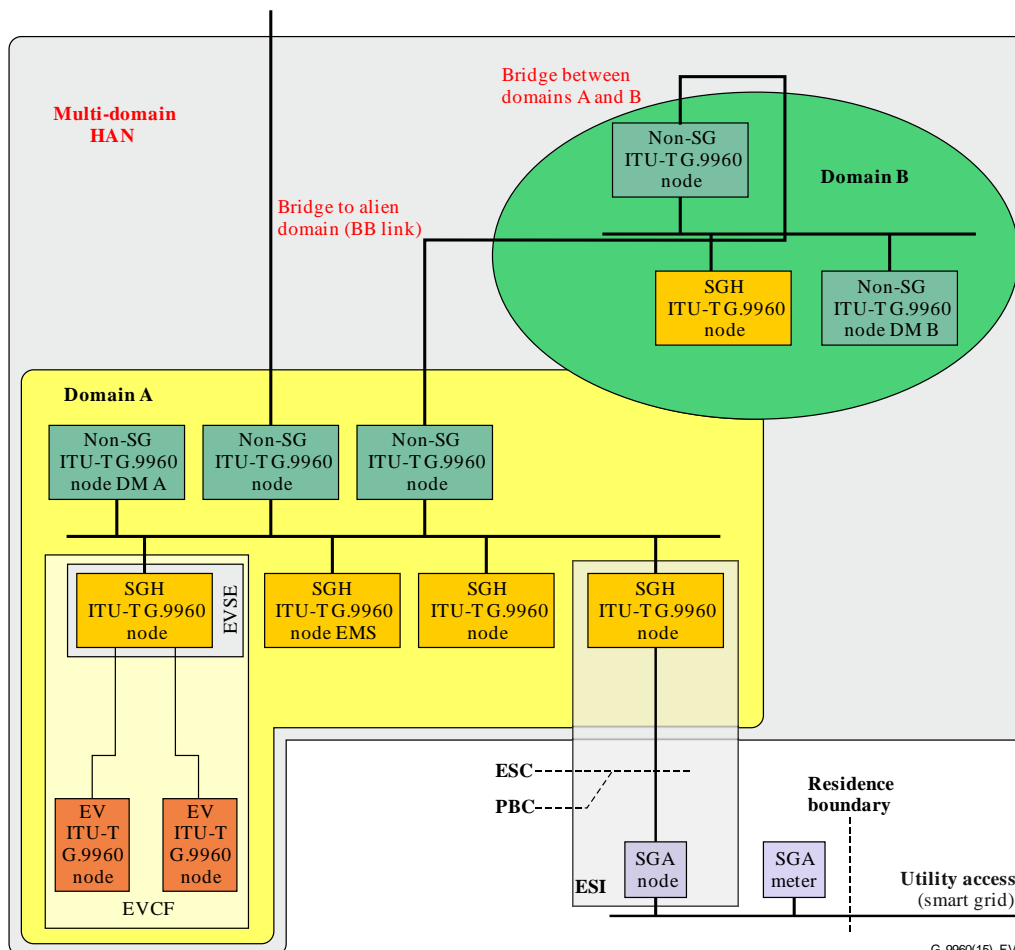

Figure V.5 – Illustration of smart grid HAN with EVCF implementation based on ITU-T G.9960

NOTE – The SGH nodes and non-SG nodes relate to smart grid and non-smart grid applications, respectively, both complying with this Recommendation.

The EVSE contains an SG node that may interface with the HAN (directly, or via an IDB, if the HAN is a non-ITU-T G.9960 network) and with the utility network via the ESI or via a broadband services provider through a HAN broadband gateway.

V.4 Authorization of an EV

The EV node, upon being notified of the active J-1772 link, seeks to establish connection to the nearest proxy node, in this case the EVSE. Once establishing communication with the EVSE node, the EV node uses the normal ITU-T G.9960 registration and authentication procedures through the EVSE node, using it as a proxy. The authorization is supported by the utility remotely through a trusted channel to the utility established from the EVSE via the ESI and access network. Through this trusted channel the utility validates the EV's identity credentials and authorizes its access in the EVCF as well as the EVSE to charge the EV at a certain maximum charge rate, for a certain time, and at a certain moment. The protocol of utility authorization is outside the scope of this Recommendation.

V.5 Charging an EV without an EVSE

In the event the EV is to be charged and no EVSE is available, the EV may have an option for plugging it in to a standard mains outlet using a cable other than a J-1772 cable. This option is for further study.

Appendix VI

Support of AMI applications in ITU-T G.9960

(This appendix does not form an integral part of this Recommendation.)

VI.1 Introduction

Advanced meter infrastructure (AMI) is a term used for a two-way meter information delivery system that uses modern digital and information technology to provide improved reliability, security, efficiency, and ultimately lower utility costs. AMI is the enabler of consumer smart grid applications as it is the means of providing information and control messages from the utility, or third-party services providers, to the premises while providing the means of delivering the meter data, and any customer queries to the utility back office systems for processing.

This appendix describes how the AMI application and related terminal devices are accommodated by the ITU-T G.9960 architecture. The architecture incorporates nodes that operate as part of an AMI network, and describes mechanisms to connect the HAN to an AMI network.

In this appendix, ITU-T G.9960-compliant nodes that operate in the AMI network are called ITU-T G.9960 AMI meter (AM) or AMI sub-meter (ASM) nodes.

To help meet the complexity and energy consumption requirements for AM and ASM applications, the ITU-T G.9960 nodes may be based on low-complexity profiles. Nodes of low-complexity profiles are fully interoperable with other nodes operating in the same domain.

VI.2 AMI topology

A typical topology of a low voltage (LV) part of a utility access network (UAN) is shown in Figure VI.1. The LV part starts from the medium voltage to low voltage (MV-LV) transformer and includes an LV line with multiple drop lines connected to residential meters, sub-meters or ESIs. A residence may have one or more AMI devices installed.

Depending on the number of drops off of the LV transformer feed, the aggregator (also known as AMI network head end, hub or collector) may be installed next to the MV-LV transformer. However, the physical location of the aggregator is implementation dependent and independent of the layout of the UAN.

In an ITU-T G.9960 AMI network, the head end node could be located by either transformer and, through the use of relay nodes and couplers, it could manage a domain that includes AMI nodes at each AMI node shown or alternatively, the deployment may consist of two domains, with one domain per LV drop from the transformer.

Note that there are regional differences in UAN topologies. These differences, such as number of AMI nodes operating on an LV drop from a transformer, are outside of the scope of this Recommendation and not discussed here. However, ITU-T G.9960 supports the various UAN topologies used.

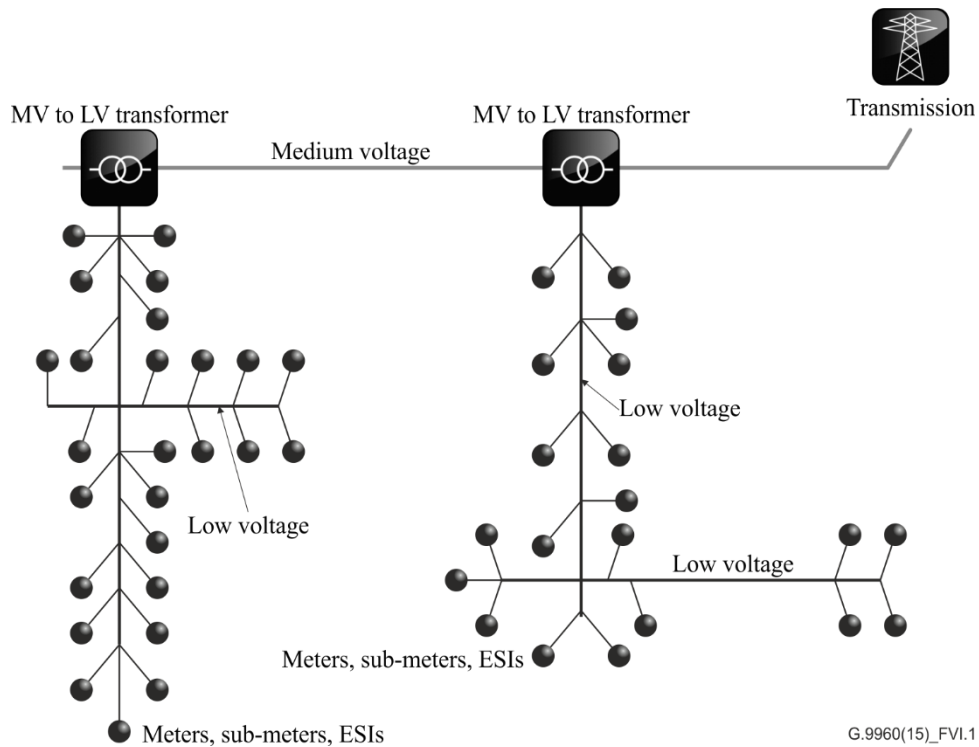

Figure VI.1 – Typical LV UAN layout

VI.3 ITU-T G.9960 AMI architecture

The network architecture of a typical ITU-T G.9960 AMI network, which is a standard ITU-T G.9960 architecture, is based on the AMI topology shown in Figure VI.1 and is presented in Figures VI.2, VI.3 and VI.4. The examples represent, respectively, two separate AMI networks, one AMI network over a single domain that covers two low-voltage branches, and an AMI network with two coordinated domains where a global master's function resides in one of the two head ends.

The root of the domain is an ITU-T G.9960 node in the AMI head end (HE), which is the domain master. The domain master of AMI domain 2 is in the second AMI head end (Figure VI.2). Each domain in Figure VI.2 is its own AMI network.

In Figure VI.3 the single domain has been extended through the use of couplers and relays to cover both LV branches and the MV leg between them. In this example, the AMI network consists of one domain that includes AMI devices and relays.

In Figure VI.4, the AMI network consists of two domains with a bridging function performed at HE 2 to route traffic from HE 1's domain to the utility SG network and BO systems.

The ITU-T G.9960 nodes installed in meters and other AMI devices operate as relays to propagate signals from remote residences to the HE or to another meter relay, and as registration proxies to admit new ITU-T G.9960 AMI nodes to the domain. ESIs operate as bridges to their HAN. There may be a sub-meter within a residence (e.g., for an EVSE); therefore, there would be a need for a node there as well.

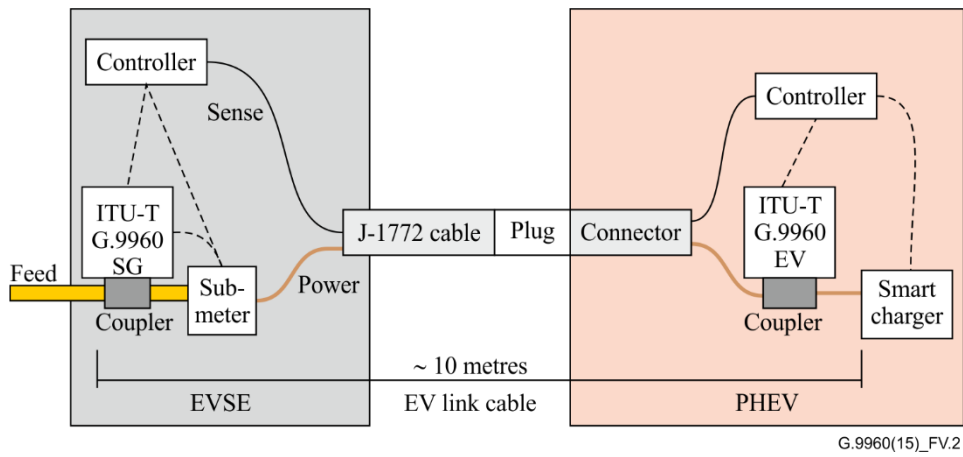

Figure VI.2 – AMI networks view 1

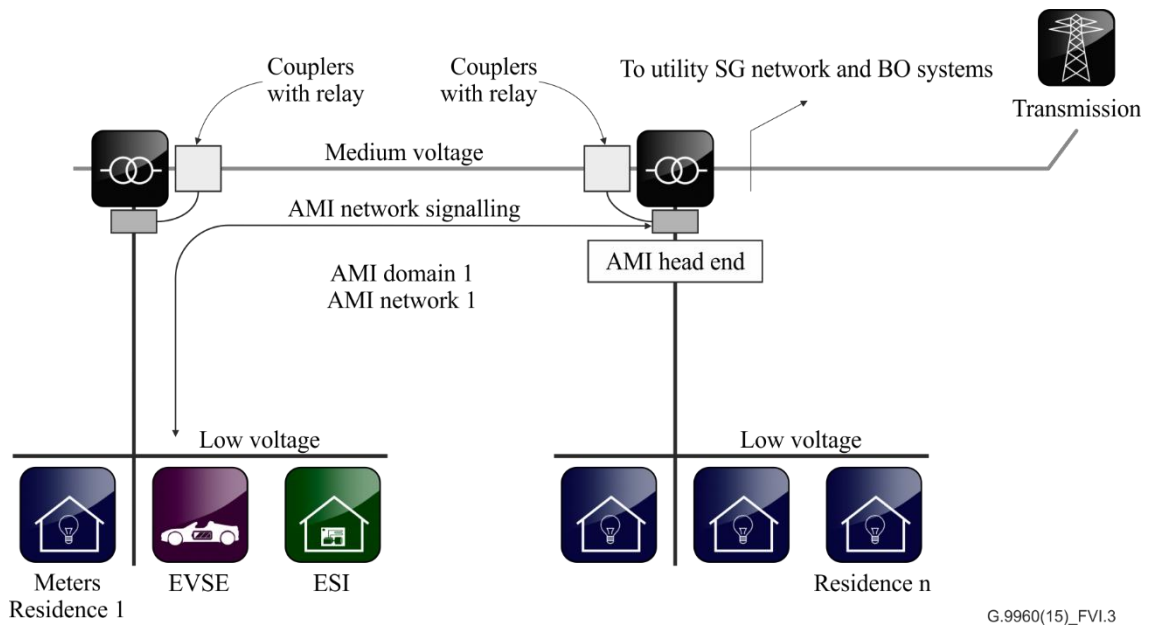

Figure VI.3 – AMI networks view 2

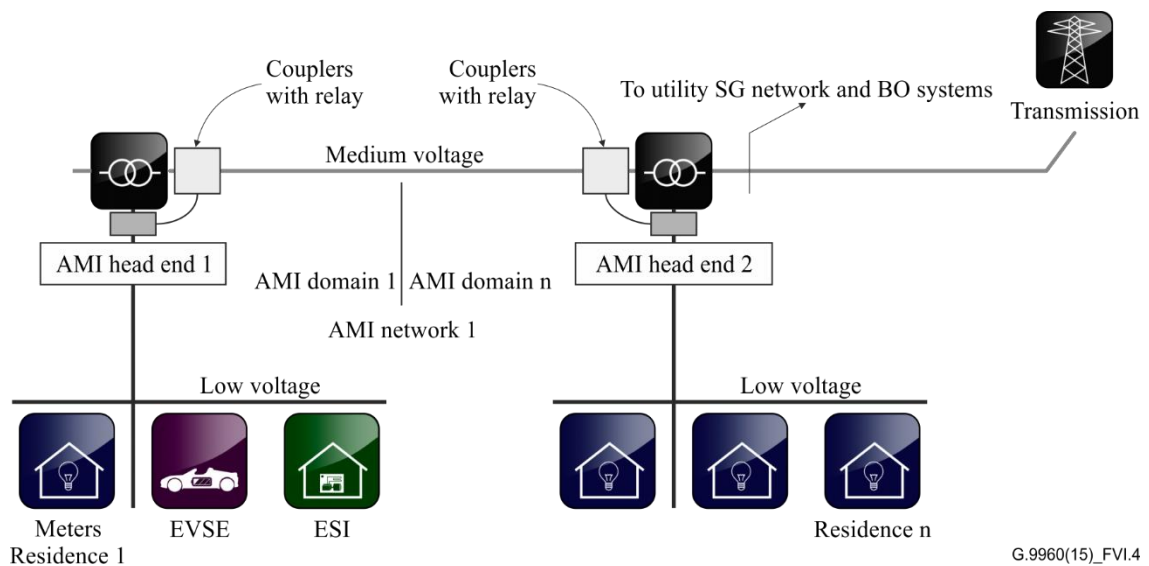

Figure VI.4 – AMI networks view 3

The bit rate and the QoS for communications between ITU-T G.9960 AMI nodes are set to meet the AMI application requirements. The ITU-T G.9960 scheduled inactivity mechanism allows further reduction of the power consumption of ITU-T G.9960 AMI nodes. The ESI devices bridge the AMI to the residential HAN.

ITU-T G.9960 supports very large AMI deployments through the use of the global master (GM) function. The GM enables up to 16 domains, each with 250 nodes, to coordinate activities and be centrally managed. Thus, a large AMI network branch of 4000 AMI nodes could be established with an unlimited number of network branches which are able to be deployed over an area.

VI.4 ITU-T G.9960 AMI mesh network

ITU-T G.9960 AMI networks are mesh networks by the very nature of ITU-T G.9960. Each meter node is a possible relay for any other node and the failure of any one link may be overcome by the use of other means to make a frame reach its destination. As can be seen in Figure VI.5, the AMI domain has established paths (black solid lines), for either direct links between the HE and meters or via relay nodes, and possible reroutes (red dashed lines). If any of the established paths fails, the nodes automatically reconfigure their routing to ensure communications is maintained.

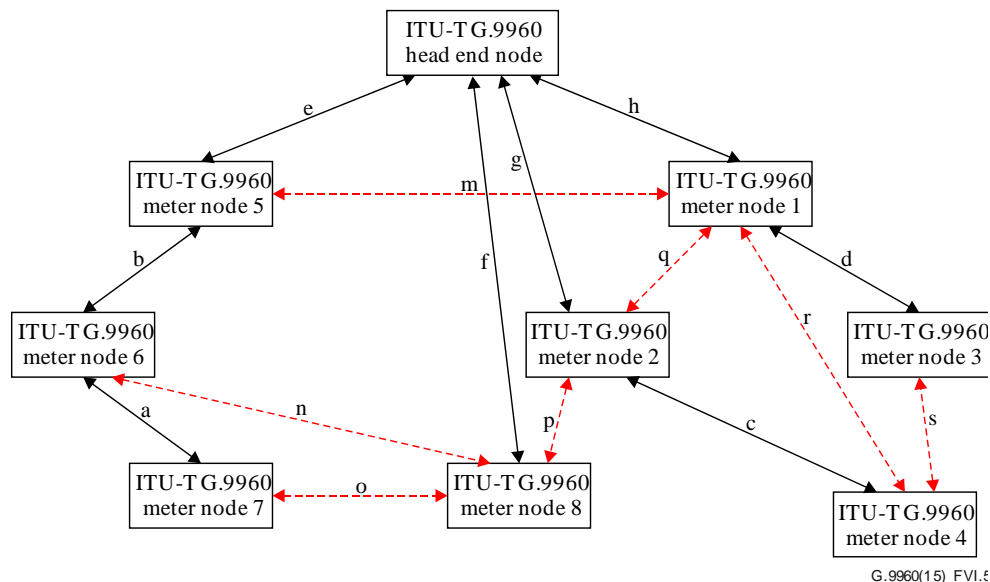

Figure VI.5 – ITU-T G.9960 mesh network ability

VI.5 Security concerns and AMI networks

The ITU-T G.9960 domain provides data security over layers 1 and 2 as it traverses the AMI link between meter and head end. The ITU-T G.9960 AMI network is an integral component of the utility's secure SG infrastructure and functions cohesively within the infrastructure.

The AMI security requirements that ITU-T G.9960 addresses can be summarized as:

- Confidentiality – Unauthorized persons cannot access AMI data intentionally or unintentionally; therefore, data is accessible only by authorized persons and systems.
- Integrity – Data delivered over the AMI network is identical to the source data and complete. No unauthorized modifications, deletions or additions have occurred to the data between the meter and the AMI head end.

VI.5.1 ITU-T G.9960 security for an AMI application

Heretofore, wired LAN design assumed that network nodes are closely controlled and that access to connectivity is restricted. Specifically, a typical wired LAN configuration is predicated on dedicated and engineered wiring, selective connectivity, and a bounded communications realm (signals

remained within the limited physical area covered by the LAN cabling). This is in effect a "closed LAN". Conversely, the open and uncontrolled nature of a power-line network negates these assumptions. Coax, to some degree, is also an open environment.

The shared nature of ITU-T G.9960 mediums requires a robust set of security services to counter threats that may arise from the unbounded nature of ITU-T G.9960 signals over power line or coax, bringing ITU-T G.9960 domain security up to the level inherent in closed LAN designs. Enhanced data confidentiality, node authentication, node-to-node message encryption, and replay threat protection are part of the suite of security services ITU-T G.9960 employs.

ITU-T G.9960 encryption is based on the advanced encryption standard (AES) according to [FIPS 197], and Counter Mode with Cipher Block Chaining Message Authentication Code algorithm (CCM) recommended by [NIST-SP800-38C]. The CCM protocol (CCMP) includes the CCM encryption mechanism, and a particular format in which the encrypted frame shall be communicated, to facilitate decryption.

ITU-T G.9960 security services have the following features:

- encryption based on AES-128 and CCM/CCMP;
- advanced authentication and secure admission of nodes into a domain, based on [\[ITU-T X.1035\]](#);
- key management, including generation, secure communication, update and termination of encryption keys;
- high confidentiality and integrity of all transactions, due to point-to-point authentication and unique encryption keys for unicast and multicast communications;
- support of secure (encrypted) operation over relay nodes: relay nodes do not possess encryption keys of the relayed frames;
- allows simultaneous operation of distinct, separately secured domains on the same medium, such as those which would be found where an ITU-T G.9960 HAN and an ITU-T G.9960 AMI network overlap;
- procedures for setting up a secure network that can be self-contained in its processes or open to secure communications with a security controlling entity that is remote from the AMI network;
- periodic re-registration, re-authentication and encryption key updates.

In an AMI deployment, all terminal devices (meters, sub-meters, ESIs, devices on the utility-secured HAN) shall be registered with the utility's back office systems. Only devices approved by the utility may be admitted to the network. For admission and authentication purposes, a trusted secure channel has to be established between the HE, the security controller (SC) and the utility BO systems. For the ITU-T G.9960 AMI domains, it is preferable that the SC function is implemented in HE nodes. The [\[ITU-T G.9961\]](#) admission procedure allows two types of "registered" admission of AMI devices, each one secure:

- a preset admission, where each device is preprogrammed by the utility with the domain name of the domain it is intended to join;
- a blind admission, when the device has no utility preprogrammed domain name.

In the case of preset admission, the AMI device registers to the AMI domain with the appropriate domain name using standard ITU-T G.9960 admission procedures. In the case of blind admission, the utility communicates the MAC address of the device to be installed to the HE, and the HE uses this MAC address as the registration code to perform the admission procedure. In both cases, admission is a plug-and-play procedure, with no action required from on-site or remote personnel, except to install the device at the appropriate location.

For authentication, each device shall be preprogrammed with a password that is known to the utility; the programming can be performed by either the utility or by the manufacturer. The installer or the end user of the AMI device does not know this password.

After admission to the domain, the AMI device sends an authentication request to the SC. To authenticate the device, the HE searches for the actual password of the device using the device MAC address; if the HE does not find the password in its database, it requests the password from the utility entity head-end via the trusted channel. If no password is identified, the HE denies the authentication and forces the device to resign from the domain.

After the password is identified, the SC may verify this password with the utility BO systems; if the BO response is positive, the standard ITU-T G.9960 authentication procedure between the authenticating device and the SC starts. Upon successful authentication, the device may apply for encryption keys to communicate with the HE (or any other allowed AMI node in the residence).

The replay detection and avoidance service defines a means by which a node that receives an MPDU from another node can detect whether the received frame is authentic or is an unauthorized retransmission. Sequence number validation, a security nonce, and MPDU timestamps are used for replay protection.

Besides admission and authentication procedures, which ensure that only permitted nodes can join an AMI network via one of its domains; ITU-T G.9960 defines point-to-point security, allowing unique encryption keys for each pair of communicating nodes or per multicast group. The point-to-point security service provides another layer of protection against an intruder that has broken through the admission control, and maintains full confidentiality for all communications within the network. This enables ITU-T G.9960 AMI networks to provide, at a minimum, the same grade of security and confidentiality as defined in the most recent specification for wireless LAN [b-IEEE 802.11-2007].

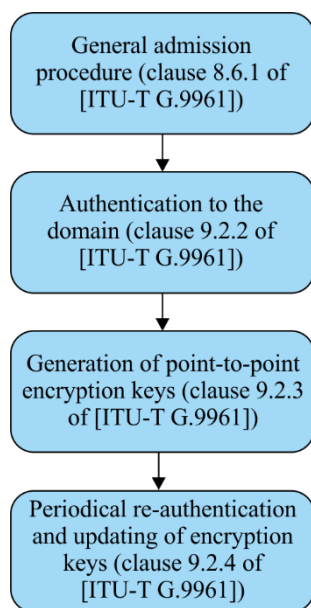

G.9960(15)_FVI.6

Figure VI.6 – ITU-T G.9960 authentication and key management (AKM) procedures

VI.5.2 AMI network security threats and counter measures

An ITU-T G.9960 AMI network provides the security services to counter threats and ensure the requirements for layers 1 and 2 are met.

VI.5.3 Confidentiality

Confidentiality threats are related to unauthorized access to information. ITU-T G.9960 counters these threats with the following services.

- Registration – A node must have the domain identity to be able to request registration. The head end (domain master) then determines if further nodes should be allowed to register to join the domain. If the HE determines the node may register, such as having received a command from the BO systems to allow new nodes to register, the HE assigns it node identification and notifies the node it is registered. Registration in and of itself does not allow a node to exchange data with any other nodes in the AMI network. The means to allow or disallow new node registrations can be managed remotely, thus preventing false registrations.
- Authentication – Once a node has registered with an HE, it must then contact the security controller (SC) for security authentication as an authentication supplicant. The SC may have functions separate from the HE and may have functions that are geographically separate or functions that are dependent on geographically separate approval services (e.g., utility BO systems' authentication approval). The SC may or may not be co-located with the HE/domain master. Once security authentication is acquired, the supplicant node is now allowed to exchange data over the AMI link.
- Keys – There are two types of keys in the ITU-T G.9960 AMI domain, the node-to security controller (NSC) key and the node-to-node (NN) keys. A node uses the NSC to communicate with the SC to establish NN keys, re-authenticate, and regenerate keys. While ITU-T G.9960 supports the use of a network master key (NMK), this mode of operation is not for use in an AMI deployment.
- Silent rejection of unencrypted or incorrectly encrypted messages – Meter nodes are restricted in this application to requiring keys for all data exchange. Any messages that arrive at a meter or HE node that should have been encrypted and are not immediately and "silently" rejected (no return message regarding the rejection sent to the originator and the receiving MAC discards the message).
- Inter-nodal communications restriction – There is a restriction that can be applied to restrict the meter nodes from exchanging data or management messages with any other but the HE and one or more dedicated ESI and sub-meters. The SC restricts all other meter-to-meter or meter-to-node communications. When a meter node acts as a relay for another meter node, it cannot decrypt the frame it relays, it only retransmits to the next relay or intended recipient, as needed.
- Re-authentication – A node is required to re-authenticate periodically. Re-authentication in an AMI network is required. Furthermore, after a communication link disruption between a meter and the HE, ITU-T G.9960 requires mandatory re-registration and re-authentication.
- Regenerating keys – From time to time, the SC may initiate a routine update of encryption keys. The frequency of routine updates is vendor discretionary, although the period of updates shall be much longer than the duration of the procedure to establish the corresponding key but shall not exceed 24 hours.

VI.5.4 Integrity

Integrity threats are related to unauthorized modification or theft of information. In addition to the countering services listed above for securing confidentiality, ITU-T G.9960 counters these threats with the following services:

- Use of a 13-byte nonce to validate a received frame's origin and frame sequence, another service that counters replay attacks and attacks on the integrity of the frame.
- The CCM encryption algorithm complies with the NIST recommendation SP 800-38C. The data integrity is assured through its use and the use of a message integrity check (MIC) value

that is embedded in the message. Furthermore, part of the header data that is not encrypted is included in the MIC calculation; therefore, any false information in the header will cause the MIC to fail its decoding validation, causing the message to be rejected.

VI.6 ITU-T G.9960 AMI coexistence with ITU-T G.9960 in-home systems

Neighbouring networks are still being defined within ITU-T. The current expectation is that it will provide a means of coexistence with minimal impact on the in-home domain's throughput. When a neighbouring ITU-T G.9960 domain is detected and it shares the MAC cycle with the AMI domain, the AMI domain should restrict the use of the MAC cycle to a maximum of 10% of the time in any MAC cycle, with an average usage of 5% across several MAC cycles.

VI.7 ITU-T G.9960 AMI networks interaction with other systems in the local loop

ITU-T G.9960 AMI may cause interference to other non-ITU-T G.9960 systems currently deployed in the field. To reduce its potential impact, ITU-T G.9960 AMI systems should reduce the maximum PSD by 10 dB with respect to the limit PSD defined for ITU-T G.9960 using the PSD shaping descriptor (Table 8-78 of [\[ITU-T G.9961\]](#)). This reduction in PSD should not significantly affect the ability of ITU-T G.9960 AMI to provide the expected service since the throughput required for AMI is low (ITU-T G.9960 AMI is expected to use low bit per subcarrier or RCM).

VDSL2 is a system that could be affected by ITU-T G.9960. As VDSL2 may be configured according to several "plans" (see Annex E of [\[ITU-T G.9964\]](#)), there are established tables for settings that will be set in the presence of the VDSL2 service. Currently, there is an ongoing study within ITU-T for the auto-detection of the VDSL2 service by ITU-T G.9960 nodes and the affected nodes' actions mandated after such detection. In case there is no auto-detection of VDSL2 by ITU-T G.9960 nodes, there is another ongoing study for defining a standard control message (which will then be configurable via [b-TR-069] ACS or a layer-2 management message) that instructs the domain master (be it in-home power line or AMI) to set the affected nodes in the domain to work in a mode "compatible with profile X" according to Annex E of [\[ITU-T G.9964\]](#). The definition and means for determining the "affected nodes" is also for further study.

Regardless of the means for signalling the presence of VDSL2, the nodes shall work in a mode that either notches or reduces PSD in downstream VDSL2 bands to reduce impact on the VTU-R reception. The impact on upstream VDSL2 bands by an AMI service is for further study, as it is different from an in-home power-line domain.

VI.8 ITU-T G.9960 and the smart grid

As shown, the ITU-T G.9960 architecture supports smart grid services delivery in the home and in AMI networks. The security available with ITU-T G.9960 is available for in-home as well as AMI applications, enabling robust and secure communications the utility can depend on. The ability of ITU-T G.9960 to operate over any wire medium means that smart grid services can be delivered to a larger group of appliances, consumer electronic devices, and low voltage systems typically not tied to the SG previously.

In an AMI network, ITU-T G.9960 meets all requirements, including those for layers 1 and 2 security and for the number of AMI nodes supported.

Bibliography

- [[b-ITU-T J.112](#)] Recommendation ITU-T J.112 (1998), *Transmission systems for interactive cable television services*.
- [[b-ITU-T J.122](#)] Recommendation ITU-T J.122 (2007), *Second-generation transmission systems for interactive cable television services – IP cable modems*.
- [[b-ITU-T J.222.1](#)] Recommendation ITU-T J.222.1 (2007), *Third-generation transmission systems for interactive cable television services – IP cable modems: Physical layer specification*.
- [b-TR-069] Broadband Forum TR-069 (2004), *CPE WAN management protocol*.
- [b-IEC CISPR 16-1-1] IEC CISPR 16-1-1:2010, *Specification for radio disturbance and immunity measuring apparatus and methods*.
- [b-IEC CISPR 22] IEC CISPR 22:2008, *Information technology equipment – Radio disturbance characteristics – Limits and methods of measurement*.
- [b-IEC 60793-2-40] International Standard IEC 60793-2-40:2009, *Optical fibres – Part 2-40: Product specifications – Sectional specification for category A4 multimode fibres*.
- [b-IEC 61754-21] International Standard IEC 61754-21:2005, *Fibre optic connector interfaces – Part 21: Type SMI connector family for plastic optical fibre*.
- [b-IEC 61754-24] International Standard IEC 61754-24:2009, *Fibre optic interconnecting devices and passive components – Fibre optic connector interfaces – Part 24: Type SC-RJ connector family*.
- [b-IEEE 802.11] IEEE 802.11-2007, *IEEE standard for Information technology – Telecommunications and information exchange between systems – Local and metropolitan area networks – Specific requirements – Part 11: Wireless LAN Medium Access Control (MAC) and Physical Layer (PHY) Specifications*.
- [b-Announcement] Japanese Ministry of Internal Affairs and Communications, *Announcement of channel plan for terrestrial digital TV broadcasting* (Japanese).
<http://www.soumu.go.jp/s-news/2008/080331_11.html>
- [b-CTBL] Cable Television Broadcast Law (Japanese).
<<http://law.e-gov.go.jp/htmldata/S47/S47F04001000040.html>>
- [b-Regulations] Radio Wave Law Enforcement Regulations Article 46-2 (Japanese).
<<http://law.e-gov.go.jp/htmldata/S25/S25F30901000014.html>>
- [b-Schedule] Japanese Ministry of Internal Affairs and Communications, *Schedule* (Japanese).
<http://www.soumu.go.jp/joho_tsusin/whatsnew/digital-broad/when_en.html>
- [b-Spectrum] Japanese Ministry of Internal Affairs and Communications, *Spectrum Charts* (Japanese).
<<http://www.tele.soumu.go.jp/e/search/myuse/use0303/index.htm>>
- [b-STD-013] Japan Cable Television Engineering Association (JCTEA) STD-013-2.0, *Transmission System for MDU* (Japanese).
<<http://www.catv.or.jp/jctea/>>

SERIES OF ITU-T RECOMMENDATIONS

Series A	Organization of the work of ITU-T
Series D	General tariff principles
Series E	Overall network operation, telephone service, service operation and human factors
Series F	Non-telephone telecommunication services
Series G	Transmission systems and media, digital systems and networks
Series H	Audiovisual and multimedia systems
Series I	Integrated services digital network
Series J	Cable networks and transmission of television, sound programme and other multimedia signals
Series K	Protection against interference
Series L	Environment and ICTs, climate change, e-waste, energy efficiency; construction, installation and protection of cables and other elements of outside plant
Series M	Telecommunication management, including TMN and network maintenance
Series N	Maintenance: international sound programme and television transmission circuits
Series O	Specifications of measuring equipment
Series P	Terminals and subjective and objective assessment methods
Series Q	Switching and signalling
Series R	Telegraph transmission
Series S	Telegraph services terminal equipment
Series T	Terminals for telematic services
Series U	Telegraph switching
Series V	Data communication over the telephone network
Series X	Data networks, open system communications and security
Series Y	Global information infrastructure, Internet protocol aspects, next-generation networks, Internet of Things and smart cities
Series Z	Languages and general software aspects for telecommunication systems