

International Telecommunication Union

ITU-T

TELECOMMUNICATION
STANDARDIZATION SECTOR
OF ITU

G.999.1

(02/2019)

SERIES G: TRANSMISSION SYSTEMS AND MEDIA,
DIGITAL SYSTEMS AND NETWORKS

Digital sections and digital line system – Metallic access
networks

**Interface between the link layer and the physical
layer for digital subscriber line (DSL)
transceivers**

Recommendation ITU-T G.999.1

ITU-T



ITU-T G-SERIES RECOMMENDATIONS

TRANSMISSION SYSTEMS AND MEDIA, DIGITAL SYSTEMS AND NETWORKS

INTERNATIONAL TELEPHONE CONNECTIONS AND CIRCUITS	G.100–G.199
GENERAL CHARACTERISTICS COMMON TO ALL ANALOGUE CARRIER-TRANSMISSION SYSTEMS	G.200–G.299
INDIVIDUAL CHARACTERISTICS OF INTERNATIONAL CARRIER TELEPHONE SYSTEMS ON METALLIC LINES	G.300–G.399
GENERAL CHARACTERISTICS OF INTERNATIONAL CARRIER TELEPHONE SYSTEMS ON RADIO-RELAY OR SATELLITE LINKS AND INTERCONNECTION WITH METALLIC LINES	G.400–G.449
COORDINATION OF RADIOTELEPHONY AND LINE TELEPHONY	G.450–G.499
TRANSMISSION MEDIA AND OPTICAL SYSTEMS CHARACTERISTICS	G.600–G.699
DIGITAL TERMINAL EQUIPMENTS	G.700–G.799
DIGITAL NETWORKS	G.800–G.899
DIGITAL SECTIONS AND DIGITAL LINE SYSTEM	G.900–G.999
General	G.900–G.909
Parameters for optical fibre cable systems	G.910–G.919
Digital sections at hierarchical bit rates based on a bit rate of 2048 kbit/s	G.920–G.929
Digital line transmission systems on cable at non-hierarchical bit rates	G.930–G.939
Digital line systems provided by FDM transmission bearers	G.940–G.949
Digital line systems	G.950–G.959
Digital section and digital transmission systems for customer access to ISDN	G.960–G.969
Optical fibre submarine cable systems	G.970–G.979
Optical line systems for local and access networks	G.980–G.989
Metallic access networks	G.990–G.999
MULTIMEDIA QUALITY OF SERVICE AND PERFORMANCE – GENERIC AND USER-RELATED ASPECTS	G.1000–G.1999
TRANSMISSION MEDIA CHARACTERISTICS	G.6000–G.6999
DATA OVER TRANSPORT – GENERIC ASPECTS	G.7000–G.7999
PACKET OVER TRANSPORT ASPECTS	G.8000–G.8999
ACCESS NETWORKS	G.9000–G.9999

For further details, please refer to the list of ITU-T Recommendations.

Recommendation ITU-T G.999.1

Interface between the link layer and the physical layer for digital subscriber line (DSL) transceivers

Summary

Recommendation ITU-T G.999.1 defines a point-to-point interface between the LINK layer device such as a network processor and a PHY device supporting multiple DSL lines, such as VDSL2, ADSL2 and SHDSL.

This revision adds support for 2.5 Gbit/s and 10 Gbit/s LINK/PHY physical interfaces.

History

Edition	Recommendation	Approval	Study Group	Unique ID*
1.0	ITU-T G.999.1	2009-10-09	15	11.1002/1000/9677
1.1	ITU-T G.999.1 (2009) Cor. 1	2010-04-22	15	11.1002/1000/10703
1.2	ITU-T G.999.1 (2009) Amd.1	2014-04-04	15	11.1002/1000/12091
2.0	ITU-T G.999.1	2019-02-22	15	11.1002/1000/13755

Keywords

Broadband access, copper pairs, LINK/PHY interface, 1 Gbit/s, 2.5 Gbit/s, 10 Gbit/s

* To access the Recommendation, type the URL <http://handle.itu.int/> in the address field of your web browser, followed by the Recommendation's unique ID. For example, <http://handle.itu.int/11.1002/1000/11830-en>.

FOREWORD

The International Telecommunication Union (ITU) is the United Nations specialized agency in the field of telecommunications, information and communication technologies (ICTs). The ITU Telecommunication Standardization Sector (ITU-T) is a permanent organ of ITU. ITU-T is responsible for studying technical, operating and tariff questions and issuing Recommendations on them with a view to standardizing telecommunications on a worldwide basis.

The World Telecommunication Standardization Assembly (WTSA), which meets every four years, establishes the topics for study by the ITU-T study groups which, in turn, produce Recommendations on these topics.

The approval of ITU-T Recommendations is covered by the procedure laid down in WTSA Resolution 1.

In some areas of information technology which fall within ITU-T's purview, the necessary standards are prepared on a collaborative basis with ISO and IEC.

NOTE

In this Recommendation, the expression "Administration" is used for conciseness to indicate both a telecommunication administration and a recognized operating agency.

Compliance with this Recommendation is voluntary. However, the Recommendation may contain certain mandatory provisions (to ensure, e.g., interoperability or applicability) and compliance with the Recommendation is achieved when all of these mandatory provisions are met. The words "shall" or some other obligatory language such as "must" and the negative equivalents are used to express requirements. The use of such words does not suggest that compliance with the Recommendation is required of any party.

INTELLECTUAL PROPERTY RIGHTS

ITU draws attention to the possibility that the practice or implementation of this Recommendation may involve the use of a claimed Intellectual Property Right. ITU takes no position concerning the evidence, validity or applicability of claimed Intellectual Property Rights, whether asserted by ITU members or others outside of the Recommendation development process.

As of the date of approval of this Recommendation, ITU had received notice of intellectual property, protected by patents, which may be required to implement this Recommendation. However, implementers are cautioned that this may not represent the latest information and are therefore strongly urged to consult the TSB patent database at <http://www.itu.int/ITU-T/ipr/>.

© ITU 2019

All rights reserved. No part of this publication may be reproduced, by any means whatsoever, without the prior written permission of ITU.

Table of Contents

	Page
1 Scope.....	1
2 References.....	1
3 Definitions	1
4 Abbreviations and acronyms	1
5 Reference model	2
6 Encapsulation.....	3
6.1 Fragmentation.....	3
6.2 Identification.....	5
6.3 Data flow control.....	5
6.4 Ethernet adaptation.....	7
6.5 Error detection	8
6.6 Resulting encapsulation format and bit-ordering	8
7 Configuration parameters	9
Annex A – Stream identification with multi-line DSL PHY devices.....	11
Annex B – LINK/PHY physical interface using 1000BASE-KX (1 Gbit/s Ethernet)	12
Annex C – LINK/PHY physical interface using 2.5GBASE-KX (2.5 Gbit/s Ethernet)	15
Annex D – LINK/PHY physical interface using 10GBASE-KR (10 Gbit/s Ethernet)	18
Bibliography.....	21

Recommendation ITU-T G.999.1

Interface between the link layer and the physical layer for digital subscriber line (DSL) transceivers

1 Scope

This Recommendation defines an interface between a LINK device and a PHY device. The interface is a single point-to-point interconnection from the LINK layer device to a PHY device, and it is intended for use with all current and developing xDSL Recommendations (e.g., ADSL2, VDSL2, SHDSL, G.fast, etc.).

2 References

The following ITU-T Recommendations and other references contain provisions which, through reference in this text, constitute provisions of this Recommendation. At the time of publication, the editions indicated were valid. All Recommendations and other references are subject to revision; users of this Recommendation are therefore encouraged to investigate the possibility of applying the most recent edition of the Recommendations and other references listed below. A list of the currently valid ITU-T Recommendations is regularly published. The reference to a document within this Recommendation does not give it, as a stand-alone document, the status of a Recommendation.

[ITU-T G.992.3] Recommendation ITU-T G.992.3 (2009), *Asymmetric digital subscriber line transceivers 2 (ADSL2)*.

[ITU-T G.992.5] Recommendation ITU-T G.992.5 (2009), *Asymmetric digital subscriber line (ADSL) transceivers – Extended bandwidth ADSL2 (ADSL2plus)*.

[ITU-T G.9701] Recommendation ITU-T G.9701 (2019), *Fast access to subscriber terminals (G.fast) – Physical layer specification*.

[IEEE 802.3] IEEE 802.3-2018, *IEEE Standard for Ethernet*.
<http://standards.ieee.org/>

[IEEE 802.3cb] IEEE 802.3cb-2018, *IEEE Standard for Ethernet – Amendment 1: Physical Layer Specifications and Management Parameters for 2.5 Gb/s and 5 Gb/s Operation over Backplane*.
<http://standards.ieee.org/>

3 Definitions

No definitions are provided for this Recommendation.

4 Abbreviations and acronyms

This Recommendation uses the following abbreviations and acronyms:

DEST MAC ADD	Destination MAC Address
DFC	Data Flow Control
EoF	End of Frame
ETH	Ethernet encapsulation function
FCS	Frame Check Sequence
GMII	Gigabit Media Independent Interface
IFG	Inter-Frame Gap

MAC	Media Access Control
MDI	Media Dependent Interface
MII	Media Independent Interface
PCP	Priority Code Point
PRE	Preamble
RXC_MFS	Maximum Fragment data Size supported by near-end receiver
SFD	Start Frame Delimiter
SID	Stream Identification
SoF	Start of Frame
SOURCE MAC ADD	Source MAC Address
TCI	Tag Control Identifier
TPID	Tag Protocol Identifier
TX_MFS	Maximum Fragment data Size to be used by near-end transmitter
TXC_MFS	Maximum Fragment data Size supported by near-end transmitter
VLAN	Virtual Local Area Network
XGMII	10 Gigabit Media Independent Interface
XOFF	Transmit Off
XON	Transmit On

5 Reference model

The LINK/PHY interface reference model is shown in Figure 5-1. This reference model shows the following primitives defined in Annex K of [ITU-T G.992.3] and Annex K of [ITU-T G.992.5]. Primitives are labelled n , where n corresponds to an individual stream, with $n = 0..N-1$ for a LINK/PHY interface transporting N streams.

- Stream(n).request: This primitive is used by the transmit PHY port to request one or more data units from the transmit LINK layer function to be transported. By the interworking of the request and confirm, the data flow is matched to the PHY port configuration (and underlying functions).
- Stream(n).confirm: The transmit LINK layer function passes one or more data units to the PHY port to be transported with this primitive.
- Stream(n).indicate: The transmit PHY port passes one or more data units to the receive LINK layer function that have been transported with this primitive.

The data unit is a block of data consisting of an integer number of octets for transport between a PHY port and a link port. The contents of a data unit is vendor discretionary and outside the scope of this Recommendation. For example, a data unit may contain an Ethernet frame, an Ethernet bonding fragment, one or more ATM cells or an ATM AAL5 PDU.

The LINK/PHY interface reference model adds the following blocks:

- frag: Fragmentation of each data unit, with a tag control identification (TCI) field added to each fragment, and with each fragment not to exceed the configured maximum fragment length;
- tag: Identification of fragments through insertion of a data stream or pause identification tag into the TCI field;

- ETH: Ethernet adaptation by adding fields for compliance with the IEEE 802.3 frame format; the ETH block is configurable to be used or not;
- FCS: Error detection through addition of frame-check-sequence;
- PAUSE: Data flow control through a single PAUSE unit containing the data flow control states of all N streams;
- dec: Decapsulation to recover data units (confirm and indicate primitives) and data flow control states (request primitives), comprising the reverse operation of the frag, tag, and ETH blocks.

Data unit encapsulation is defined as the cascade of the frag, tag, ETH and FCS blocks. Pause init encapsulation is defined as the cascade of the PAUSE, ETH and FCS blocks. Encapsulation overhead depends on whether or not the ETH block is used.

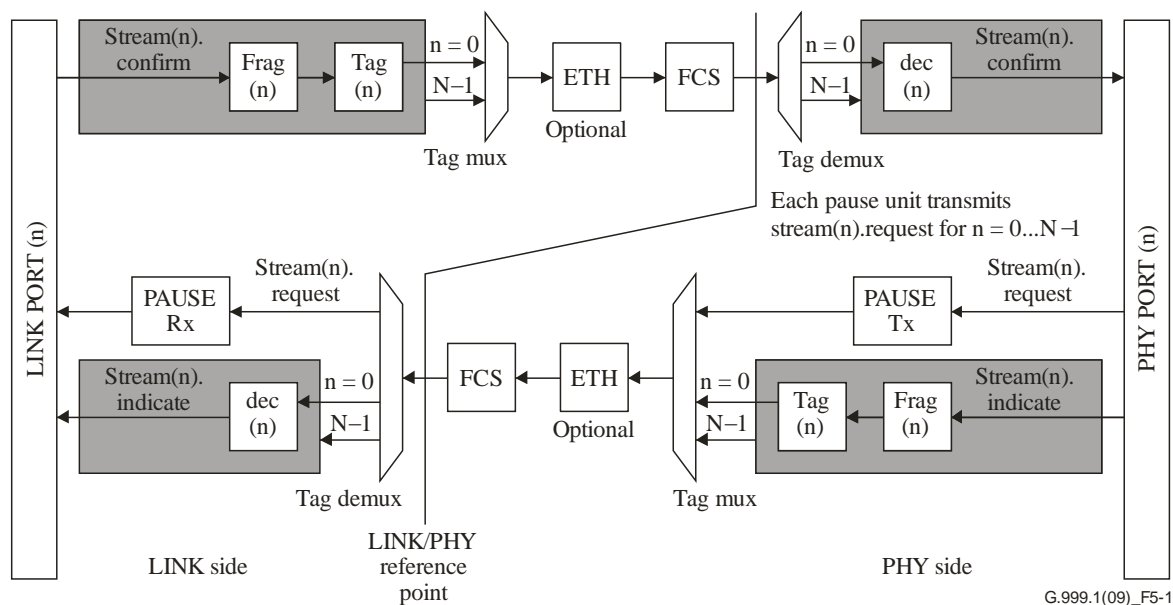

Figure 5-1 – Reference model for the LINK/PHY interface

The LINK device and PHY device shall use a physical point-to-point interconnection. The LINK/PHY interface shall support a data rate of at least 1 Gbit/s for the encapsulated data units. The minimum required bit rate at the LINK/PHY reference point may be higher (e.g., 1.25 Gbit/s if 8B/10B encoding is used).

6 Encapsulation

6.1 Fragmentation

The fragmentation block (see Figure 5-1) shall fragment each data unit as shown in Figure 6-1. The fragment format is shown in Figure 6-2.

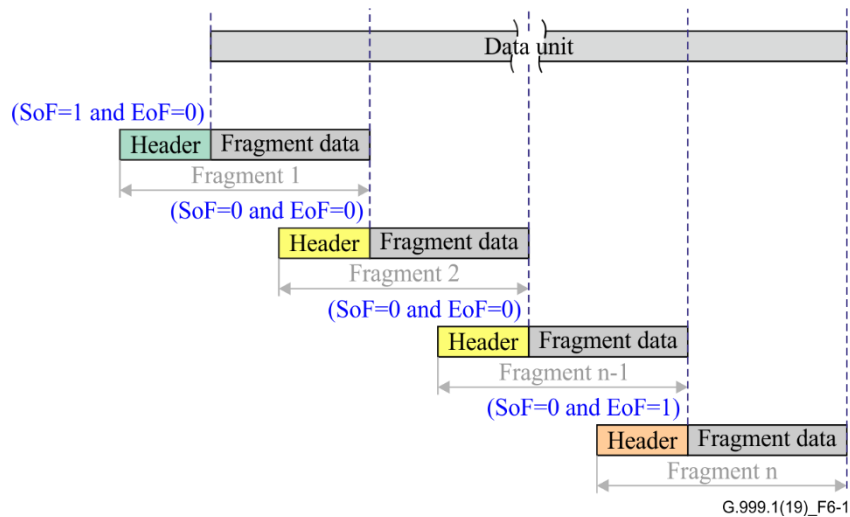

Figure 6-1 – Data unit fragmentation

		LSB						MSB	
2 octets	TCI	0	0	0	0	0	1	EoF	SoF
		0	0	0	0	0	0	0	0
2 octets	LENGTH								
N octets	Fragment data								

G.999.1(19)_F6-2

Figure 6-2 – Non-tagged fragment format

The fragment header shall consist of the tag control identifier (TCI) field and the LENGTH field. The capability to insert the LENGTH field is mandatory. When Ethernet encapsulation is enabled, the LENGTH field shall be inserted. When Ethernet encapsulation is disabled, the LENGTH field is configurable to be used or not (see Table 7-1). When the LENGTH MODE is set to 1, the LENGTH field shall be appended; otherwise, the LENGTH field shall not be appended. In the TCI field, the [SoF] and [EoF] bits shall be defined as shown in Table 6-1. The remaining TCI bits shall be as defined in Figure 6-2 and partly further defined by the tag function. The LENGTH field shall contain the number of data unit octets in the fragment data field.

The LENGTH field, in which the value is encoded as a 16-bit unsigned integer, shall be transmitted with the high order (i.e., most significant) octet first.

Table 6-1 – Definition of the data unit delimiters

[SoF]	[EoF]	Description
0	0	Next fragment of data unit
1	0	First fragment of data unit
0	1	Last fragment of data unit
1	1	Single fragment data unit

For each fragment, the value of the length field shall not exceed the maximum fragment data size (TX_MFS). If the length of a data unit is less than or equal to the TX_MFS value (see Table 7-1), then that data unit shall be transmitted as a single fragment (i.e., SoF = 1 and EoF = 1). If the length of a data unit is higher than the TX_MFS value, then that data unit shall be transmitted in multiple fragments, where fragments may have the same or a different length.

The value of TX_MFS shall be configurable and shall not exceed the near-end maximum transmit fragment data size (TXC_MFS), and it shall not exceed the far-end maximum receive fragment data size (RXC_MFS). If TX_MFS is configured as ZERO, then each data unit shall be transmitted as a single fragment. The valid values of TX_MFS, TXC_MFS, and RXC_MFS are all integers in the range from 0 to 2047 (included). For interface data rates > 1 Gbit/s, the PHY device shall indicate TXC_MFS = 2047 and RXC_MFS = 2047, i.e., all fragment sizes up to 2047 bytes shall be supported by the PHY device.

NOTE – For interface data rates ≤ 1 Gbit/s, there are no mandatory values defined for the TXC_MFS and RXC_MFS.

6.2 Identification

The tag block (see Figure 5-1) shall tag each data fragment's TCI field with the stream identification (SID) value, resulting in the tagged fragment format shown in Figure 6-3.

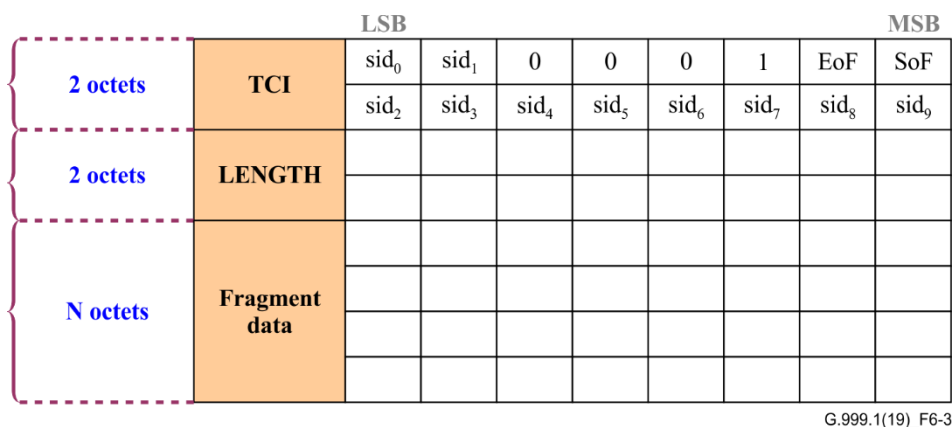

Figure 6-3 – Tagged fragment format

The valid SID value is any 10-bit unsigned integer. Up to 1024 data streams can be identified.

The allocation of a SID value to each data stream is technology dependent, and is defined in Annex A for DSL transceivers.

6.3 Data flow control

Data flow control (DFC) is a mechanism that prevents congestion by ensuring that transmitting devices do not overwhelm receiving devices with data. This is achieved by the receiving device informing in advance the transmitting device when no further data can be received (e.g., when the RX-Buffer-Filling becomes critical), after which the transmitter stops transmission (= Transmission-Off = XOFF = Active-Backpressure) until the receiver indicates in the same manner that it has regained ability to receive data (e.g., enough free RX-Buffer-Resources) and transmission may continue (= Transmission-On = XON = Inactive-Backpressure).

For the LINK/PHY interface, data flow control is defined independently for both the transmission of data from the (transmitting) LINK device to the (receiving) PHY device and for the transmission of data from the (transmitting) PHY device to the (receiving) LINK device. Data flow control is defined per data stream to prevent loss of data units.

To control the data flow from the transmitting device to the receiving device, the receiving device may transmit pause units to the transmitting device. The format of the pause unit is shown in Figure 6-4.

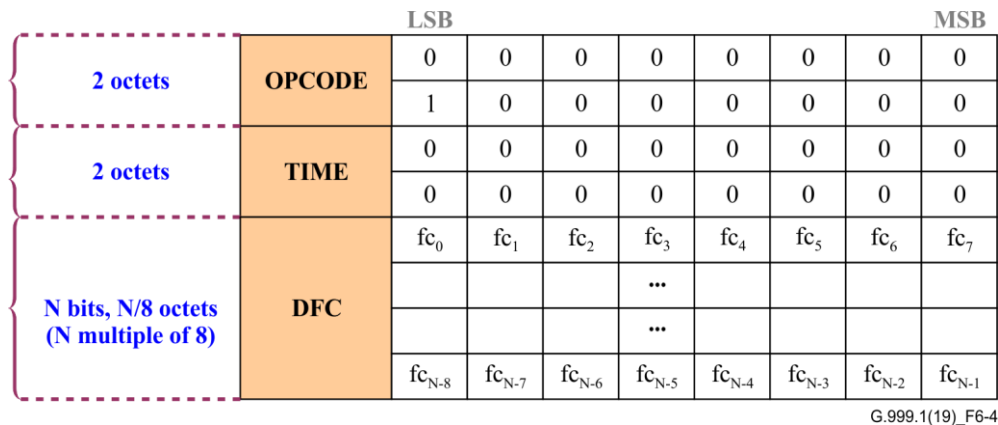

Figure 6-4 – Pause unit format

The OPCODE field shall be set to 0x0001 (i.e., the Ethernet MAC control opcode for pause frame). The OPCODE value allows to uniquely distinguish pause units from tagged data fragments.

The TIME field shall be set to 0x0000 (i.e., the Ethernet pause frame value for immediate resume of transmission).

The DFC field shall contain N/8 octets, where N represents the highest used SID, incremented to the next multiple of 8. The N data flow control bits [fc₀..fc_{N-1}] represent the data flow control states for the stream with SID = 0 up to the stream with SID = N-1. A data flow control bit shall be set to 0 to indicate the XON-State and shall be set to 1 to indicate XOFF-State for the respective data stream. A data flow control bit corresponding to an unused SID shall be set to 0.

Upon reception of a pause unit from a receiving device, the transmitting device shall stop transmission within the XOFF-latency as specified in Table 6-2 for the data streams with their flow control bit set to XOFF in this PAUSE unit.

Upon reception of a pause unit from a receiving device, the transmitting device shall resume transmission for all the data streams with their flow control bit set to XON in this PAUSE unit and was set to XOFF in the last transmitted PAUSE unit and for which the last transmitted fragment was not the last fragment of a data unit. For the case when only one data stream is turned on, transmission of this data stream shall be resumed within the XON-latency as specified in Table 6-2. For the case when multiple data streams are turned on, transmission of data streams should be resumed within XON-latency, if the interface rate allows to transmit at least one fragment for each non-paused data stream within XON-latency.

Table 6-2 – Specification of XON/XOFF-latencies

XOFF-latency	XON-latency	LINK/PHY physical interface
10 μs	240 μs	Annex B (1000Base-KX)
8 μs	T _S – (XOFF-latency)	Annex C (2.5GBASE-KX)
5 μs	T _S – (XOFF-latency)	Annex D (10GBASE-KR)
NOTE – T _S = 20 μs if one of the supported technologies is G.fast according to [ITU-T G. 9701], otherwise T _S = 250 μs.		

The XOFF-latency and XON-latency are referred to the LINK/PHY-reference point (see Figure 5-1). The XOFF-latency shall be measured from the last FCS bit of the PAUSE unit transmitted by the PHY device to the last FCS bit of the last fragment transmitted by the LINK-side for the concerned data stream. The XON-latency shall be measured from the last FCS bit of the PAUSE unit transmitted by the PHY device to the last FCS bit of the first fragment transmitted by the LINK-side for the concerned data stream.

If a data stream is in the XON-state, then the transmitter shall manage the time in-between the transmission of consecutive data fragments belonging to the same data unit, so as to avoid data underflow in the reassembly of the data units at the receiving side.

Operation with flow control on the PHY-to-LINK data stream (i.e., where the LINK device is the receiving device) is enabled only if the corresponding capability is indicated by both the LINK and PHY devices per the configuration parameter FCTL-us (see Table 7-1).

6.4 Ethernet adaptation

The ETH block shown in Figure 5-1 adds fields to tagged fragments and Pause Units for compliance with [IEEE 802.3] (data and pause) frame format (after addition of FCS, see clause 6.5).

The ETH block shall be supported on the PHY-side and shall be configurable to be used or not. On the LINK-side, support of the ETH block is optional; however, if supported, it shall be configurable to be used or not.

The ETH block shall prepend Source MAC Address field, Destination MAC Address field, VLAN TPID field and MAC TYPE field to tagged fragments and pause units as shown in Figure 6-5.

The ETH block shall append a padding field to guarantee the frame contains at least 64 octets after addition of FCS. Padding octets shall be set to 0x00.

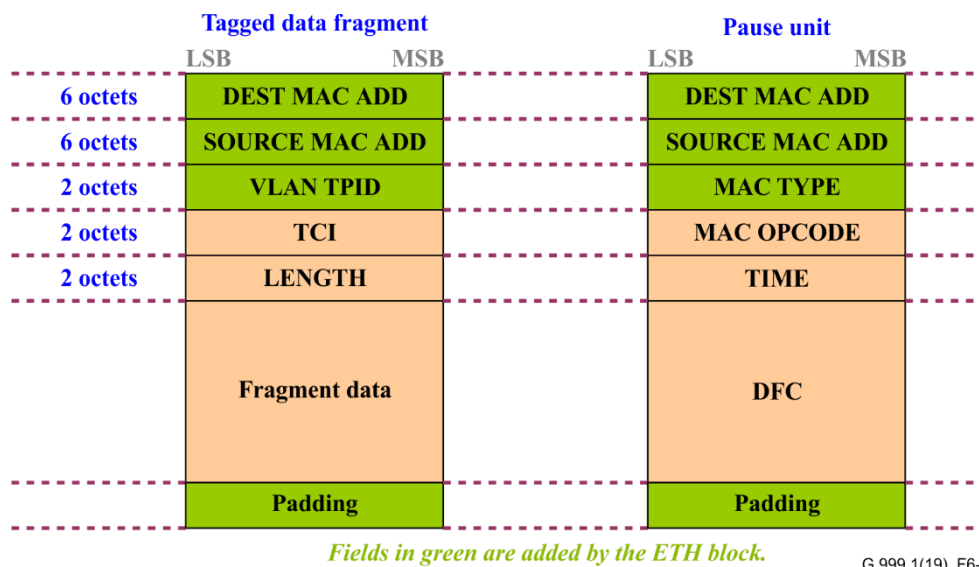

Figure 6-5 – Ethernet adapted format

The destination MAC address shall be set to the MAC address of the far-end device. For pause frames, the destination MAC address may also be set to the globally assigned multicast address 0x0180C2000001. This multicast address has been reserved by [IEEE 802.3] for use in MAC-Control-PAUSE frames.

The source MAC address shall be set to the near-end device MAC address.

The VLAN TPID shall be set to 0x8100. This is the VLAN Tag Protocol Identifier, as defined in [IEEE 802.3].

The MAC TYPE shall be set to 0x8808. This is the MAC Control Type for pause frames, as defined in [IEEE 802.3].

The far-end (i.e., destination) MAC address shall be configurable at the LINK and PHY sides for all frames. For pause frames, it shall be configurable at the LINK side and PHY side whether to use the far-end MAC address or the multicast MAC address.

6.5 Error detection

The FCS block shown in Figure 5-1 shall append a 4-octet frame check sequence to each (Ethernet adapted) tagged data fragment or pause unit. The FCS shall be calculated over all octets in the (Ethernet adapted) tagged data fragment or pause unit. The FCS shall consist of the 32-bit CRC as defined in [IEEE 802.3] clause 3.2.9 for Ethernet frame FCS.

The addition of the FCS field is shown in Figure 6-6.

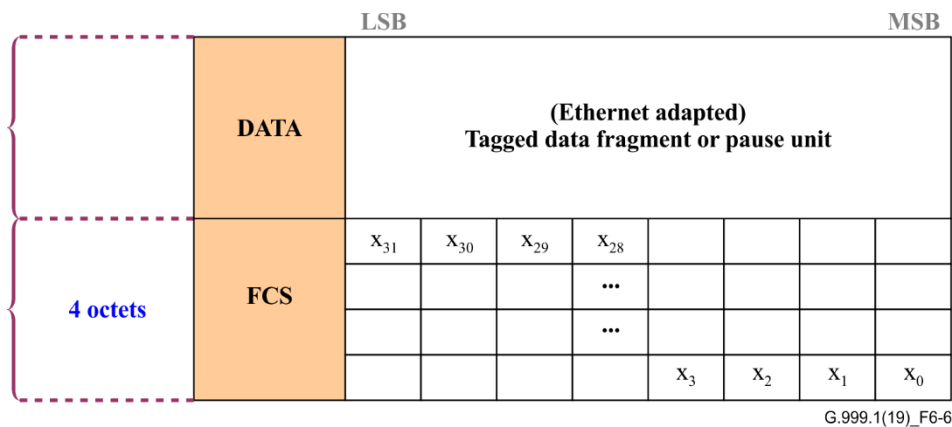

Figure 6-6 – Addition of FCS

6.6 Resulting encapsulation format and bit-ordering

When Ethernet encapsulation is not used, i.e., the ETH block is disabled, the final encapsulation format is shown in Figure 6-7. When Ethernet encapsulation is used, i.e., the ETH block is enabled, the final encapsulation format is shown in Figure 6-8. Octets shall be transmitted top-to-bottom.

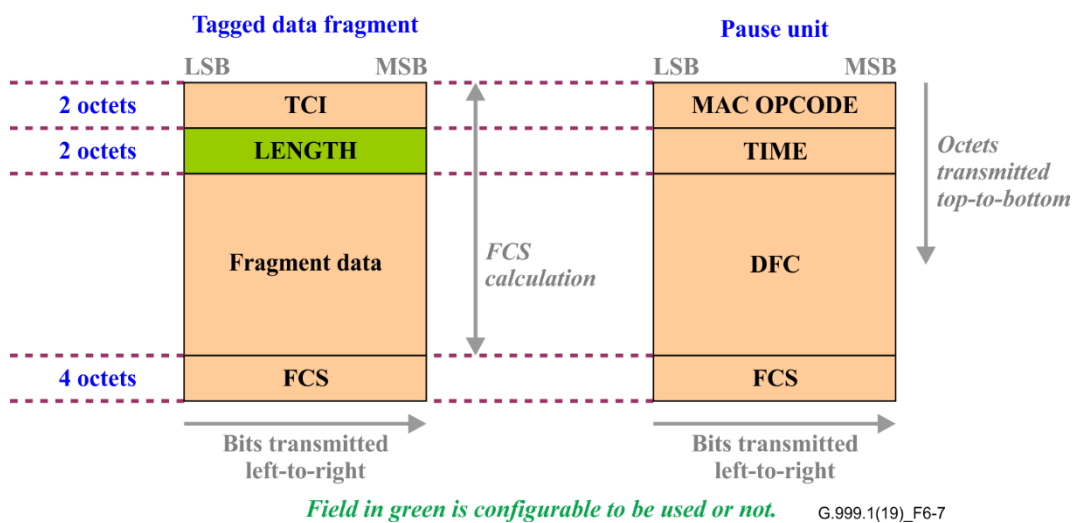

Figure 6-7 – Final encapsulation format without Ethernet encapsulation

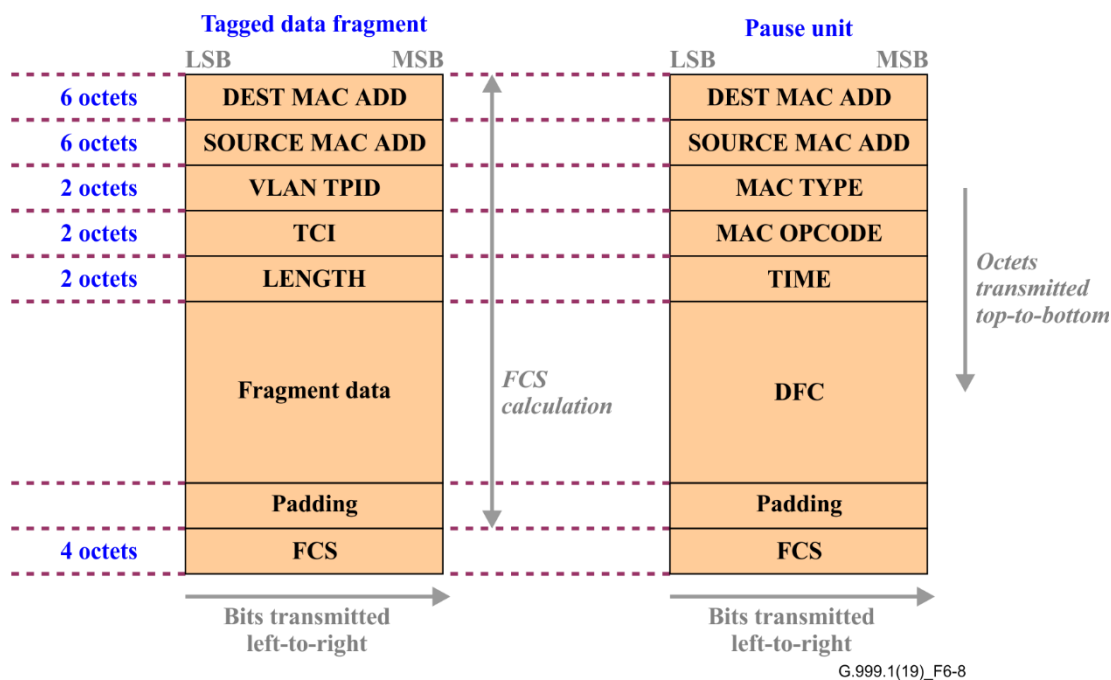

Figure 6-8 – Final encapsulation format with Ethernet encapsulation

7 Configuration parameters

Table 7-1 summarizes the encapsulation configuration parameters defined in clause 6 and defines a detailed format.

Table 7-1 – Configuration parameters for the encapsulation

NAME	SIZE	LINK	PHY	Definition
FRAGMENTATION (clause 6.1)				
TXC_MFS	[10:0]	R	R	Maximum fragment data size supported by near-end transmitter.
RXC_MFS	[10:0]	R	R	Maximum fragment data size supported by near-end receiver.
TX_MFS	[10:0]	R/W	R/W	Maximum fragment data size to be used by near-end transmitter.
LENGTH MODE	[0]	R/W	R/W	0: LENGTH field shall not be appended. 1: LENGTH field shall be appended.
FLOW CONTROL on the PHY-to-LINK data stream (clause 6.3)				
FCTL-us	[0]	R/W	R/W	0: Flow Control on the PHY-to-LINK data stream Not Supported. 1: Flow Control on the PHY-to-LINK data stream Supported.
ETHERNET ADAPTATION (clause 6.4)				
ETH	[0]	R/W	R/W	0: Ethernet Adaptation shall not be used. 1: Ethernet Adaptation shall be used.
NE_MAC_ADDRESS	[47:0]	R/W	R/W	Near-end MAC Address
FE_MAC_ADDRESS	[47:0]	R/W	R/W	Far-end MAC Address

Table 7-1 – Configuration parameters for the encapsulation

NAME	SIZE	LINK	PHY	Definition
PAUSE_MULTICAST	[0]	R/W	R/W	0: Pause frame shall have far-end MAC address as destination MAC address. 1: Pause frame shall have multicast MAC address as destination MAC address.

If the ETH bit is set to ONE, then the LENGTH MODE bit shall also be set to ONE.

Annex A

Stream identification with multi-line DSL PHY devices

(This annex forms an integral part of this Recommendation.)

DSL transceivers are based on transparent transport of data streams. A TPS-TC data stream is an input to a TPS-TC, where a data unit equals a 53-octet ATM cell (ATM-TC) (see clause K.2 of [ITU-T G.992.3] or clause K.2 of [b-ITU-T G.993.2]) or a packet (PTM-TC) (see clause K.3 of [ITU-T G.992.3] or clause K.3 of [b-ITU-T G.993.2] or clause 8.3 of [ITU-T G.9701]). In the Link/PHY interface, a data unit may, for example, contain an Ethernet frame, an Ethernet bonding fragment, one or more ATM cells or an ATM AAL5 PDU (see clause 5). A TPS-TC connects to a bearer channel. In the case of PTM-TC with pre-emption, a bearer channel may carry a high priority data stream and low priority data stream. Hence, for DSL transceivers, the stream identification (SID) shall identify a particular DSL line, a particular bearer channel and a particular priority within the bearer in the DSL line.

NOTE – The three primitives defined in clause 5 correspond to the TPS-TC primitives defined in the ADSL2 [ITU-T G.992.3] and VDSL2 [b-ITU-T G.993.2] Recommendations.

This annex defines a mapping of the stream identifier (SID) for a multi-line DSL PHY device, with up to 256 DSL lines/transceivers, up to 2 bearer channels and possible use of pre-emption.

The line/transceiver number (line[7:0], values 0 to 255), the bearer channel (BC, values 0 or 1), and the priority (PR, values 0 = low or 1 = high) shall be mapped into the stream identification (SID[9:0], values 0 to 1024) as shown in Figure A.1.

sid ₉	sid ₈	sid ₇	sid ₆	sid ₅	sid ₄	sid ₃	sid ₂	sid ₁	sid ₀
line ₇	line ₆	line ₅	line ₄	line ₃	line ₂	line ₁	line ₀	BC	PR

G.999.1(19)_FA.1

Figure A.1 – Mapping of line, bearer and priority into the SID

In general, for a PHY device supporting N transceivers, there are $N \cdot 4$ SID values and $\left\lceil \frac{N}{2} \right\rceil = \left\lceil \frac{N \cdot 4}{8} \right\rceil$ octets in the DFC field of the pause unit. For example:

- If the PHY device has 256 DSL transceivers, then the DFC field in the pause unit (see Figure 6-4) contains 128 octets.
- If the PHY device has 84 DSL transceivers, then the DFC field in the pause unit (see Figure 6-4) contains 42 octets. This is the maximum number of transceivers that keeps the encapsulated pause unit (including Ethernet adaptation) at the [IEEE 802.3] pause frame length of 64 octets.
- If the PHY device has only 12 DSL transceivers, then the DFC field in the pause unit (see Figure 6-4) contains only 6 octets. If Ethernet adaptation is used, the Ethernet frame contains 36 padding octets.

Annex B

LINK/PHY physical interface using 1000BASE-KX (1 Gbit/s Ethernet)

(This annex forms an integral part of this Recommendation.)

This annex defines the LINK/PHY physical interface, based on [IEEE 802.3] 1000BASE-KX Ethernet (also known as Backplane Ethernet). Compliance to this annex requires support of a relevant subset of [IEEE 802.3] 1000BASE-KX Ethernet (clause 70) below the GMII, which include the PCS, PMA, and PMD layers (see Table B.1 for relevant sections of 1000Base-KX). The sections of [IEEE 802.3] 1000Base-KX Ethernet (clause 70) that are not identified in Table B.1 are vendor discretionary.

Note that the GMII is an optional interface. However, if the GMII is not implemented, a conforming implementation must behave functionally as though the GMII is present.

Figure B.1 shows the LINK/PHY interface based on 1000BASE-KX. The encapsulation block is defined in the main body of this Recommendation.

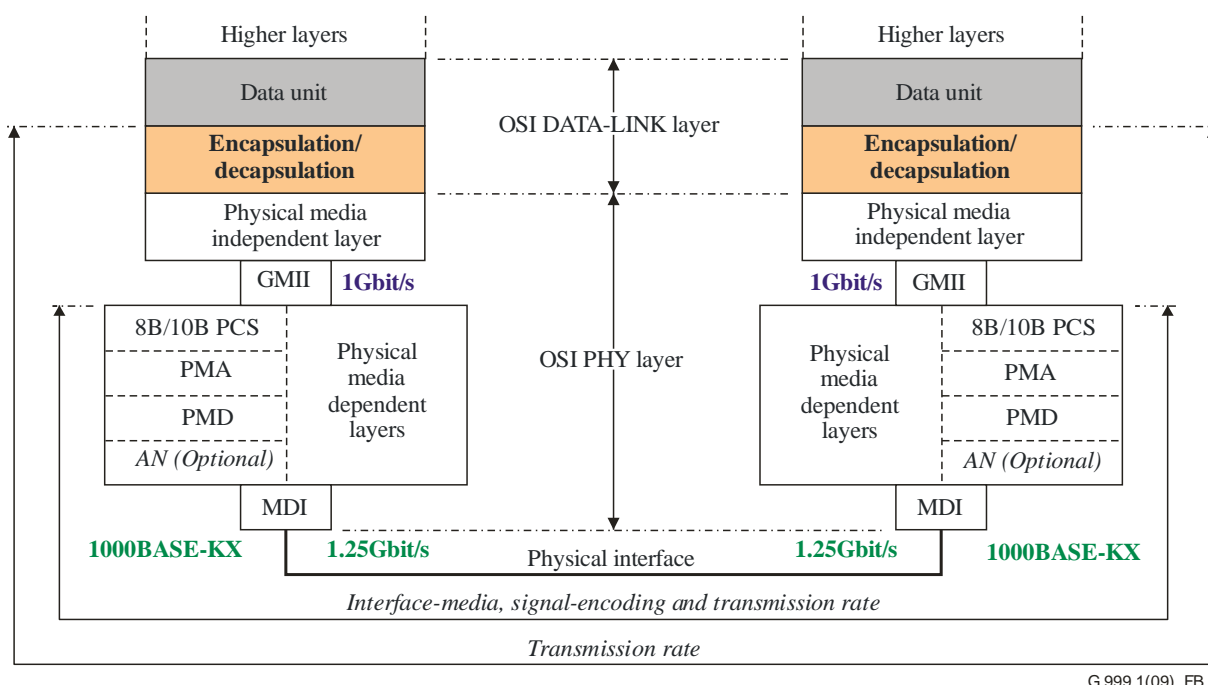

G.999.1(09)_FB.1

Figure B.1 – LINK/PHY interface based on 1000BASE-KX

The OSI's PHY-Layer part of the LINK/PHY interface (see Figure B.1):

- Shall be compliant with a relevant subset of [IEEE 802.3] 1000BASE-KX standard clause 70 per Table B.1. Note that Table B.1 lists the relevant section headings of [IEEE 802.3] clause 70 for which compliance is required: 'Req' means that full support of mandatory items in the section is required, and 'Partial' means partially supported with identification in the comment column of the appropriate elements required. Compliance to the other sections of [IEEE 802.3] clause 70 is optional.
- Shall operate in Full-Duplex mode and at 1 Gbit/s data rate at the GMII or equivalent interface (which is 1.25 Gbit/s at the MDI interface). The Auto-Negotiation capability is not necessary and therefore not required.
- The interface between the physical media independent layer and the physical media dependent layers (MII) is vendor discretionary.

- Shall use PReamble (PRE), start frame delimiter (SFD) and inter-frame-gaps (IFG) for detecting byte and (Ethernet adapted) fragment boundaries; the following Ethernet CSMA/CD MAC parameters (clauses 3 and 4 of [IEEE 802.3]) shall be applied:
 - PRE: 7 octets (clause 3.2.1)
 - SFD: 1 octet (clause 3.2.2)
 - IFG: 12 octets (clause 4.4.2)
- Optionally, the minimum number of IFG octets may be reduced to 3. If Ethernet adaptation is not used, then PReamble octets may optionally be reduced to 2.
- In general, all options can be used when both the LINK and the PHY devices are configured to support it; the means for enabling each option in the LINK and PHY devices are vendor discretionary.

Table B.1 – Subset of 1000Base-KX for Annex B compliance

Section #	Section Title	Support	Comment
70.1	Overview	Partial	w/o clause 45
70.2	Physical media dependent (PMD) service interface	Req.	w/o Signal Detect
70.4	Delay constraints	Req.	
70.6	PMD functional specifications	Partial	w/o Signal Detect
70.6.1	Link block diagram	Partial	w/o Signal Detect
70.6.2	PMD transmit function	Req.	
70.6.3	PMD receive function	Req.	
70.6.6	Loopback mode	Req.	w/o clause 45
70.7.1	Transmitter characteristics	Req.	
70.7.1.1	Test fixtures	Req.	
70.7.1.2	Test fixture impedance	Req.	
70.7.1.3	Signalling speed	Req.	
70.7.1.4	Differential output eye mask	Req.	
70.7.1.5	Output amplitude	Req.	–
70.7.1.6	Differential output return loss	Req.	
70.7.1.7	Transition time	Req.	
70.7.1.8	Transmit jitter	Req.	
70.7.1.9	Transmit jitter test requirements	Req.	
70.7.2	Receiver characteristics	Req.	
70.7.2.1	Receiver interference tolerance	Req.	
70.7.2.2	Signalling speed range	Req.	
70.7.2.3	AC-coupling	Req.	
70.7.2.4	Input signal amplitude	Req.	
70.7.2.5	Differential input return loss	Req.	
70.9	Environmental specifications	Req.	–
70.10	Protocol implementation conformance statement (PICS) proforma for clause 70, physical media dependent (PMD) sublayer and baseband medium, type 1000BASE-KX		
70.10.1	Introduction	Req.	–

Table B.1 – Subset of 1000Base-KX for Annex B compliance

Section #	Section Title	Support	Comment
70.10.3	Major capabilities/options	Partial	only PCS, FD, and DC
70.10.4.2	PMD functional specifications	Partial	only FS1, FS2, FS3, FS4, FS8, and FS9
70.10.4.4	Transmitter electrical characteristics	Req.	–
70.10.4.5	Receiver electrical characteristics	Req.	–
70.10.4.6	Environmental and safety specifications	Req.	–

Annex C

LINK/PHY physical interface using 2.5GBASE-KX (2.5 Gbit/s Ethernet)

(This annex forms an integral part of this Recommendation.)

This annex defines the LINK/PHY physical interface, based on [IEEE 802.3cb] 2.5GBASE-KX Ethernet (also known as 2.5 Gbit/s Backplane Ethernet). Compliance to this annex requires support of a relevant subset of [IEEE 802.3cb] 2.5GBASE-KX Ethernet (clause 128) below the XGMII, which include the PCS, PMA, and PMD layers (see Table C.1 for relevant sections of 2.5GBASE-KX). The sections of [IEEE 802.3cb] 2.5GBASE-KX Ethernet (clause 128) that are not identified in Table C.1 are vendor discretionary.

Note that the XGMII is an optional interface. However, if the XGMII is not implemented, a conforming implementation must behave functionally as though the XGMII is present.

Figure C.1 shows the LINK/PHY interface based on 2.5GBASE-KX. The encapsulation block is defined in the main body of this Recommendation.

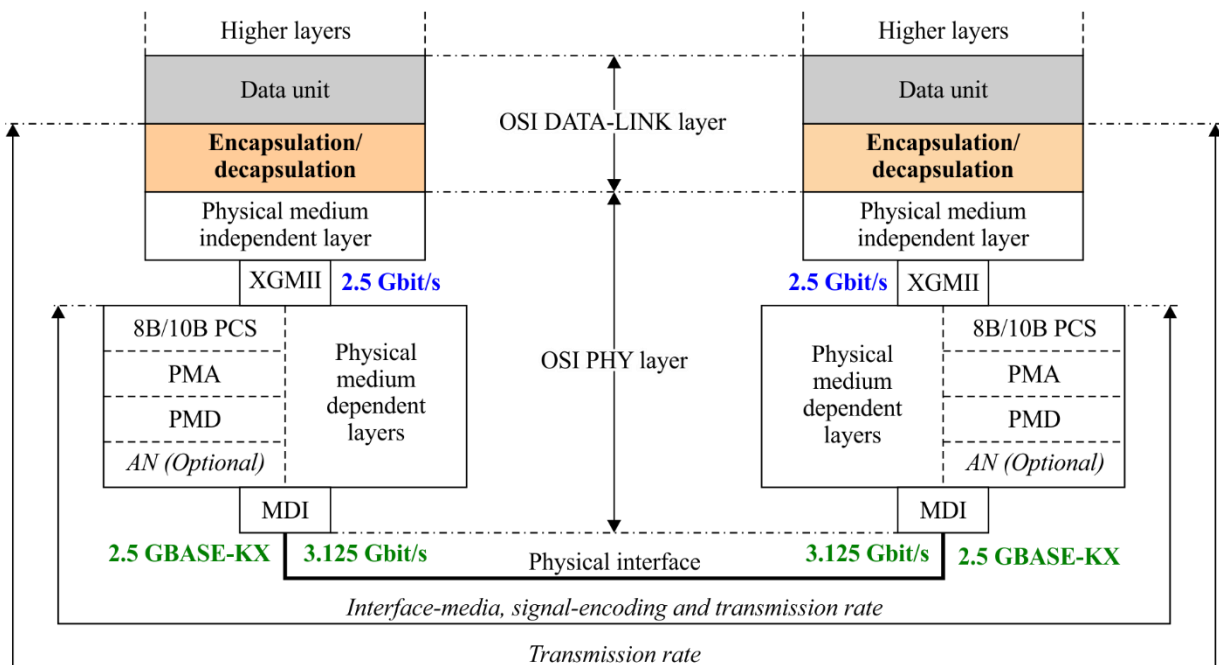

G.999.1(19)_FC-1

Figure C.1 – LINK/PHY interface based on 2.5GBASE-KX

The OSI's PHY-Layer part of the LINK/PHY interface (see Figure C.1):

- Shall be compliant with a relevant subset of [IEEE 802.3cb] 2.5GBASE-KX standard clause 128 according to Table C.1. Note that Table C.1 lists the relevant section headings of clause 128 of [IEEE 802.3cb] for which compliance is required. 'Req' means that full support of mandatory items in the section is required, and 'Partial' means partially supported with identification in the comment column of the appropriate elements required. Compliance to the other sections of clause 128 of [IEEE 802.cb] is optional.
- Shall operate in full-duplex mode and at 2.5 Gbit/s data rate at the XGMII or equivalent interface (which is 3.125 Gbit/s at the MDI interface). The auto-negotiation capability is not necessary and therefore not required.
- The interface between the physical media independent layer and the physical media dependent layers (MII) is vendor discretionary.

- Shall use PReamble (PRE), start frame delimiter (SFD) and inter-frame-gaps (IFG) for detecting byte and (Ethernet adapted) fragment boundaries. The following Ethernet CSMA/CD MAC parameters (clauses 3 and 4 of [IEEE 802.3]) shall be applied:
 - PRE: 7 octets (clause 3.2.1)
 - SFD: 1 octet (clause 3.2.2)
 - IFG: 12 octets (clause 4.4.2)
- Optionally, the minimum number of IFG octets may be reduced to 3. If Ethernet adaptation is not used, then PReamble octets may optionally be reduced to 2.
- In general, all options can be used when both the LINK and the PHY devices are configured to support it. The means for enabling each option in the LINK and PHY devices are vendor discretionary.

Table C.1 – Subset of 2.5GBASE-KX for Annex C compliance

Section #	Section Title	Support	Comment
128.1	Overview	Partial	w/o clause 45
128.2	Physical media dependent (PMD) service interface	Req.	w/o Signal Detect
128.4	Delay constraints	Req.	
128.6	PMD functional specifications	Partial	w/o Signal Detect
128.6.1	Link block diagram	Partial	w/o Signal Detect
128.6.2	PMD transmit function	Req.	
128.6.3	PMD receive function	Req.	
128.6.6	Loopback mode	Req.	w/o clause 45
128.7.1	Transmitter characteristics	Req.	
128.7.1.1	Test fixtures	Req.	
128.7.1.2	Test fixture characteristics	Req.	
128.7.1.3	Signalling speed	Req.	
128.7.1.4	Output amplitude	Req.	–
128.7.1.5	Differential output return loss	Req.	
128.7.1.6	Common-mode output return loss	Req.	
128.7.1.7	Transition time	Req.	
128.7.1.8	Transmit jitter test requirements	Req.	
128.7.1.9	Transmit jitter	Req.	
128.7.2	Receiver characteristics	Req.	
128.7.2.1	Receiver interference tolerance	Req.	
128.7.2.2	Signalling speed range	Req.	
128.7.2.3	AC-coupling	Req.	
128.7.2.4	Input signal amplitude	Req.	
128.7.2.5	Differential input return loss	Req.	
128.9	Environmental specifications	Req.	–
128.10	Protocol implementation conformance statement (PICS) proforma for clause 128, physical media dependent		

Table C.1 – Subset of 2.5GBASE-KX for Annex C compliance

Section #	Section Title	Support	Comment
	(PMD) sublayer and baseband medium, type 2.5GBASE-KX		
128.10.1	Introduction	Req.	–
128.10.3	Major capabilities/options	Partial	only PCS and DC
128.10.4.2	PMD functional specifications	Partial	only FS3, FS4, FS5, FS6, and FS11
128.10.4.3	Transmitter electrical characteristics	Req.	–
128.10.4.4	Receiver electrical characteristics	Req.	–
128.10.4.5	Environmental and safety specifications	Req.	–

Annex D

LINK/PHY physical interface using 10GBASE-KR (10 Gbit/s Ethernet)

(This annex forms an integral part of this Recommendation.)

This annex defines the LINK/PHY physical interface, based on [IEEE 802.3] 10GBASE-KR Ethernet (also known as serial 10 Gbit/s Backplane Ethernet). Compliance to this annex requires support of a relevant subset of [IEEE 802.3] 10GBASE-KR Ethernet (clause 72) below the XGMII, which include the PCS, PMA, and PMD layers (see Table D.1 for relevant sections of 10GBASE-KR). The sections of [IEEE 802.3] 10GBASE-KR Ethernet (clause 72) that are not identified in Table D.1 are vendor discretionary.

Note that the XGMII is an optional interface. However, if the XGMII is not implemented, a conforming implementation must behave functionally as though the XGMII is present.

Figure D.1 shows the LINK/PHY interface based on 10GBASE-KR. The encapsulation block is defined in the main body of this Recommendation.

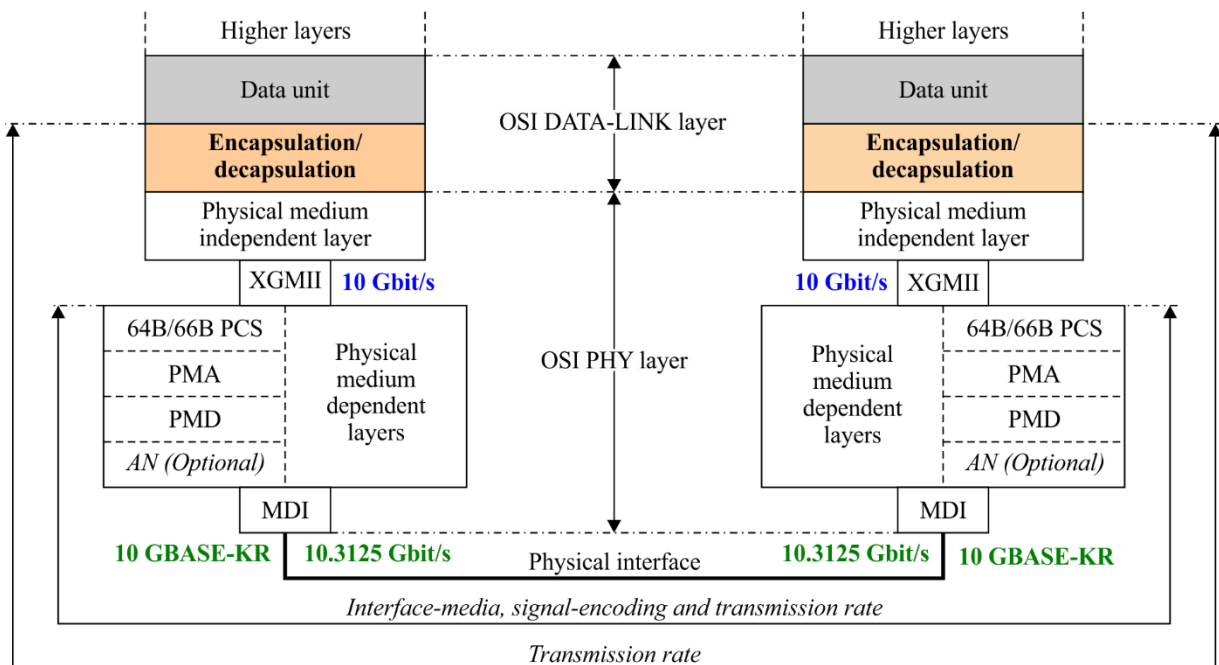

G.999.1(19)_FD-1

Figure D.1 – LINK/PHY interface based on 10GBASE-KR

The OSI's PHY-Layer part of the LINK/PHY interface (see Figure D.1):

- Shall be compliant with a relevant subset of [IEEE 802.3] 10GBASE-KR standard clause 72 according to Table D.1. Note that Table D.1 lists the relevant section headings of [IEEE 802.3] clause 72 for which compliance is required. 'Req' means that full support of mandatory items in the section is required, and 'Partial' means partially supported with identification in the comment column of the appropriate elements required. Compliance to the other sections of [IEEE 802.3] clause 72 is optional.
- Shall operate in full-duplex mode and at 10 Gbit/s data rate at the XGMII or equivalent interface (which is 10.3125 Gbit/s at the MDI interface). The auto-negotiation capability is not necessary and therefore not required.
- The interface between the physical media independent layer and the physical media dependent layers (MII) is vendor discretionary.

- Shall use PReamble (PRE), start frame delimiter (SFD) and inter-frame-gaps (IFG) for detecting byte and (Ethernet adapted) fragment boundaries. The following Ethernet CSMA/CD MAC parameters (clauses 3 and 4 of [IEEE 802.3]) shall be applied:
 - PRE: 7 octets (clause 3.2.1)
 - SFD: 1 octet (clause 3.2.2)
 - IFG: 12 octets (clause 4.4.2)
- Optionally, the minimum number of IFG octets may be reduced to 8. If Ethernet adaptation is not used, then PReamble octets may optionally be reduced to 3.
- In general, all options can be used when both the LINK and the PHY devices are configured to support it; the means for enabling each option in the LINK and PHY devices are vendor discretionary.

Table D.1 – Subset of 10GBASE-KR for Annex D compliance

Section #	Section title	Support	Comment
72.1	Overview	Partial	w/o clause 45
72.2	Physical media dependent (PMD) service interface	Req.	
72.4	Delay constraints	Req.	
72.6	PMD functional specifications	Req.	
72.6.1	Link block diagram	Req.	
72.6.2	PMD transmit function	Req.	
72.6.3	PMD receive function	Req.	
72.6.6	Loopback mode	Partial	w/o clause 45
72.6.10	PMD control function	Req.	
72.7.1	Transmitter characteristics	Req.	
72.7.1.1	Test fixtures	Req.	
72.7.1.2	Test fixture impedance	Req.	
72.7.1.3	Signalling speed	Req.	
72.7.1.4	Output amplitude	Req.	
72.7.1.5	Differential output return loss	Req.	–
72.7.1.6	Common-mode return loss	Req.	
72.7.1.7	Transition time	Partial	w/o clause 45
72.7.1.8	Transmit jitter test requirements	Partial	w/o clause 45
72.7.1.9	Transmit jitter	Req.	
72.7.1.10	Transmitter output waveform	Req.	
72.7.1.11	Transmitter output waveform requirements	Req.	
72.7.2	Receiver characteristics	Req.	
72.7.2.1	Receiver interference tolerance	Req.	
72.7.2.2	Signalling speed range	Req.	
72.7.2.3	AC-coupling	Req.	
72.7.2.4	Input signal amplitude	Req.	
72.7.2.5	Differential input return loss	Req.	
72.9	Environmental specifications	Req.	–

Table D.1 – Subset of 10GBASE-KR for Annex D compliance

Section #	Section title	Support	Comment
72.10	Protocol implementation conformance statement (PICS) proforma for clause 70, physical media dependent (PMD) sublayer and baseband medium, type 1000BASE-KX		
72.10.1	Introduction	Req.	–
72.10.3	Major capabilities/options	Partial	only PCS, PMA, and DC
72.10.4.2	PMD functional specifications	Partial	only FS1, FS2, FS3, FS4,FS7, FS8, FS9 and FS12
72.10.4.4	PMD Control functions	Req.	
72.10.4.5	Transmitter electrical characteristics	Req.	–
72.10.4.6	Receiver electrical characteristics	Req.	–
72.10.4.7	Environmental and safety specifications	Req.	–

Bibliography

- [b-ITU-T G.993.2] Recommendation ITU-T G.993.2 (2006), *Very high speed digital subscriber line transceivers 2 (VDSL2)*.
- [b-IEEE 802.1D] IEEE 802.1D-2004, *IEEE Standard for Local and metropolitan area networks Media Access Control (MAC) Bridges*, Revision of 802.1D-1998.
<http://standards.ieee.org>
- [b-IEEE 802.1Q] IEEE 802.1Q-2005, *IEEE standard for local and metropolitan area networks virtual bridged local area networks*.
<http://standards.ieee.org>

SERIES OF ITU-T RECOMMENDATIONS

Series A	Organization of the work of ITU-T
Series D	Tariff and accounting principles and international telecommunication/ICT economic and policy issues
Series E	Overall network operation, telephone service, service operation and human factors
Series F	Non-telephone telecommunication services
Series G	Transmission systems and media, digital systems and networks
Series H	Audiovisual and multimedia systems
Series I	Integrated services digital network
Series J	Cable networks and transmission of television, sound programme and other multimedia signals
Series K	Protection against interference
Series L	Environment and ICTs, climate change, e-waste, energy efficiency; construction, installation and protection of cables and other elements of outside plant
Series M	Telecommunication management, including TMN and network maintenance
Series N	Maintenance: international sound programme and television transmission circuits
Series O	Specifications of measuring equipment
Series P	Telephone transmission quality, telephone installations, local line networks
Series Q	Switching and signalling, and associated measurements and tests
Series R	Telegraph transmission
Series S	Telegraph services terminal equipment
Series T	Terminals for telematic services
Series U	Telegraph switching
Series V	Data communication over the telephone network
Series X	Data networks, open system communications and security
Series Y	Global information infrastructure, Internet protocol aspects, next-generation networks, Internet of Things and smart cities
Series Z	Languages and general software aspects for telecommunication systems