

International Telecommunication Union

ITU-T

TELECOMMUNICATION
STANDARDIZATION SECTOR
OF ITU

G.9991

Amendment 1
(07/2020)

SERIES G: TRANSMISSION SYSTEMS AND MEDIA,
DIGITAL SYSTEMS AND NETWORKS

Access networks – In premises networks

High-speed indoor visible light communication
transceiver – System architecture, physical layer
and data link layer specification

Amendment 1

Recommendation ITU-T G.9991 (2019) – Amendment 1

ITU-T



ITU-T G-SERIES RECOMMENDATIONS
TRANSMISSION SYSTEMS AND MEDIA, DIGITAL SYSTEMS AND NETWORKS

INTERNATIONAL TELEPHONE CONNECTIONS AND CIRCUITS	G.100–G.199
GENERAL CHARACTERISTICS COMMON TO ALL ANALOGUE CARRIER-TRANSMISSION SYSTEMS	G.200–G.299
INDIVIDUAL CHARACTERISTICS OF INTERNATIONAL CARRIER TELEPHONE SYSTEMS ON METALLIC LINES	G.300–G.399
GENERAL CHARACTERISTICS OF INTERNATIONAL CARRIER TELEPHONE SYSTEMS ON RADIO-RELAY OR SATELLITE LINKS AND INTERCONNECTION WITH METALLIC LINES	G.400–G.449
COORDINATION OF RADIOTELEPHONY AND LINE TELEPHONY	G.450–G.499
TRANSMISSION MEDIA AND OPTICAL SYSTEMS CHARACTERISTICS	G.600–G.699
DIGITAL TERMINAL EQUIPMENTS	G.700–G.799
DIGITAL NETWORKS	G.800–G.899
DIGITAL SECTIONS AND DIGITAL LINE SYSTEM	G.900–G.999
MULTIMEDIA QUALITY OF SERVICE AND PERFORMANCE – GENERIC AND USER-RELATED ASPECTS	G.1000–G.1999
TRANSMISSION MEDIA CHARACTERISTICS	G.6000–G.6999
DATA OVER TRANSPORT – GENERIC ASPECTS	G.7000–G.7999
PACKET OVER TRANSPORT ASPECTS	G.8000–G.8999
ACCESS NETWORKS	G.9000–G.9999
Metallic access networks	G.9700–G.9799
Optical line systems for local and access networks	G.9800–G.9899
In premises networks	G.9900–G.9999

For further details, please refer to the list of ITU-T Recommendations.

Recommendation ITU-T G.9991

High-speed indoor visible light communication transceiver – System architecture, physical layer and data link layer specification: Amendment 1

Amendment 1

Summary

Recommendation ITU-T G.9991 specifies the system architecture, physical (PHY) layer and data link layer (DLL) for high-speed indoor optical wireless communication transceiver using visible light.

Amendment 1 includes updates on security to accept IEEE 802.1X-based authentication and alignment with ITU-T G.9960/G.9961 Recommendations

History

Edition	Recommendation	Approval	Study Group	Unique ID*
1.0	ITU-T G.9991	2019-03-22	15	11.1002/1000/13781
1.1	ITU-T G.9991 (2019) Amd. 1	2020-07-07	15	11.1002/1000/14226

* To access the Recommendation, type the URL <http://handle.itu.int/> in the address field of your web browser, followed by the Recommendation's unique ID. For example, <http://handle.itu.int/11.1002/1000/11830-en>.

FOREWORD

The International Telecommunication Union (ITU) is the United Nations specialized agency in the field of telecommunications, information and communication technologies (ICTs). The ITU Telecommunication Standardization Sector (ITU-T) is a permanent organ of ITU. ITU-T is responsible for studying technical, operating and tariff questions and issuing Recommendations on them with a view to standardizing telecommunications on a worldwide basis.

The World Telecommunication Standardization Assembly (WTSA), which meets every four years, establishes the topics for study by the ITU-T study groups which, in turn, produce Recommendations on these topics.

The approval of ITU-T Recommendations is covered by the procedure laid down in WTSA Resolution 1.

In some areas of information technology which fall within ITU-T's purview, the necessary standards are prepared on a collaborative basis with ISO and IEC.

NOTE

In this Recommendation, the expression "Administration" is used for conciseness to indicate both a telecommunication administration and a recognized operating agency.

Compliance with this Recommendation is voluntary. However, the Recommendation may contain certain mandatory provisions (to ensure, e.g., interoperability or applicability) and compliance with the Recommendation is achieved when all of these mandatory provisions are met. The words "shall" or some other obligatory language such as "must" and the negative equivalents are used to express requirements. The use of such words does not suggest that compliance with the Recommendation is required of any party.

INTELLECTUAL PROPERTY RIGHTS

ITU draws attention to the possibility that the practice or implementation of this Recommendation may involve the use of a claimed Intellectual Property Right. ITU takes no position concerning the evidence, validity or applicability of claimed Intellectual Property Rights, whether asserted by ITU members or others outside of the Recommendation development process.

As of the date of approval of this Recommendation, ITU had received notice of intellectual property, protected by patents, which may be required to implement this Recommendation. However, implementers are cautioned that this may not represent the latest information and are therefore strongly urged to consult the TSB patent database at <http://www.itu.int/ITU-T/ipr/>.

© ITU 2020

All rights reserved. No part of this publication may be reproduced, by any means whatsoever, without the prior written permission of ITU.

Table of Contents

	Page
1	Scope 1
2	References..... 1
3	Definitions 2
3.1	Terms defined elsewhere 2
3.2	Terms defined in this Recommendation..... 3
4	Abbreviations and acronyms 4
5	Conventions 6
5.1	Bit ordering convention 6
6	System architecture and reference models 6
6.1	System architecture 6
6.2	Reference models 13
6.3	Management-plane model of a VLC system 15
7	Topology profiles..... 15
7.1	Topology profiles based on the operational modes 16
8	Physical layer specification I (PHY layer based on ITU-T G.9960)..... 16
8.1	Medium independent specification..... 16
8.2	Medium dependent specification..... 32
9	Physical layer specification II (ACO-OFDM)..... 35
9.1	Medium independent specification..... 35
9.2	Medium dependent specification..... 41
10	Data link layer specification 41
10.1	Functional model and frame formats..... 41
10.2	Medium access 46
10.3	Control parameters for APC, LLC and MAC 57
10.4	Functions of the end-point node 59
10.5	Domain master node functional capabilities 60
10.6	Addressing scheme 61
10.7	Medium access plan (MAP) frame..... 61
10.8	Retransmission and acknowledgement protocol 67
10.9	Management and control message format..... 67
10.10	Channel estimation protocol..... 67
10.11	Connection management 67
10.12	Operation in the presence of neighbouring domains..... 67
10.13	Inter-domain mobility support..... 68
10.14	Dimming support and flicker avoidance 70
10.15	Inter-OFB interoperability 70
10.16	MIMO transmission..... 70

	Page
10.17	Operation with non-VLC uplink 70
10.18	DLL multicast stream 70
10.19	Node information and capabilities exchange 70
10.20	Metrics acquisition protocol 70
10.21	Operation in power saving modes 70
10.22	Layer 2 configuration and management protocol..... 70
10.23	Payload compression in management messages 70
10.24	TLV Pool 71
10.25	PHY multicast binding protocol..... 71
11	Security 71
12	Management of ITU-T G.9991 nodes 71
12.1	Architecture and reference model 71
12.2	ITU-T G.9991 interface data model 73
Annex A	– LCMP communication through L1 interface 74
A.1	LCMP_CONTROL in L1 interface..... 74
A.2	Data model for L1 interface 74
Annex B	– LCMP communication through L6 interface..... 75
B.1	LCMP_CONTROL in L6 interface..... 75
B.2	Data model for L6 interface 75
Annex C	– ITU-T G.9991 Capabilities 77
C.1	ITU-T G.9991 capabilities..... 77
C.2	Excluded ITU-T G.9961 capabilities 78
Annex D	– IEEE 802.1X port-based network access control 79
Appendix I	– Introducing a DC offset when using a PHY layer based on Recommendation ITU-T G.9960..... 80
Bibliography 81

Amendment 1 to Recommendation ITU-T G.9991

High-speed indoor visible light communication transceiver – System architecture, physical layer and data link layer specification:

Amendment 1

Editorial note: This is a complete-text publication. Modifications introduced by this amendment are shown in revision marks relative to Recommendation ITU-T G.9991(2019).

1 Scope

This Recommendation specifies the system architecture and functionality for all components of the physical (PHY) layer and data link layer (DLL) of visible light communication (VLC) transceivers for in-premises applications designed for the high-speed optical wireless transmission of data using visible light and infrared communications.

Specifically, this Recommendation defines:

- high-speed VLC system architecture and reference models;
- the physical layer specifications of the different PHY layers accepted by this Recommendation;
- the data link layer specification; and
- the management layer specification.

2 References

The following ITU-T Recommendations and other references contain provisions which, through reference in this text, constitute provisions of this Recommendation. At the time of publication, the editions indicated were valid. All Recommendations and other references are subject to revision; users of this Recommendation are therefore encouraged to investigate the possibility of applying the most recent edition of the Recommendations and other references listed below. A list of the currently valid ITU-T Recommendations is regularly published. The reference to a document within this Recommendation does not give it, as a stand-alone document, the status of a Recommendation.

[ITU-T G.9960] Recommendation ITU-T G.9960 (2018), *Unified high-speed wireline-based home networking transceivers – System architecture and physical layer specification.*

[ITU-T G.9961] Recommendation ITU-T G.9961 (2018), *Unified high-speed wireline-based home networking transceivers – Data link layer specification.*

[\[ITU-T G.9962\]](#) [Recommendation ITU-T G.9962 \(2018\), Unified high-speed wire-line based home networking transceivers – Management specification.](#)

[ITU-T G.9963] Recommendation ITU-T G.9963 (2018), *Unified high-speed wireline-based home networking transceivers – Multiple input/multiple output specification.*

[ITU-T G.9964] Recommendation ITU-T G.9964 (2011), *Unified high-speed wireline-based home networking transceivers – Power spectral density specification.*

[IEC 62471-5:2015] IEC 62471-5:2015, *Photobiological safety of lamps and lamp systems – Part 5: Image projectors.*

3 Definitions

3.1 Terms defined elsewhere

This Recommendation uses the following terms defined elsewhere:

3.1.1 channel [ITU-T G.9960]: A transmission path between nodes. One channel is considered to be one transmission path. Logically, a channel is an instance of a communication medium used for the purpose of passing data between two or more nodes.

3.1.2 coding overhead [ITU-T G.9960]: A part of the overhead used to carry the coding redundancy (such as redundancy bits of error correction coding or cyclic redundancy check (CRC)).

3.1.3 data [ITU-T G.9960]: Bits or bytes transported over the medium or via a reference point that individually convey information. Data includes both user (application) data and any other auxiliary information (overhead, including control, management, etc.). Data does not include bits or bytes that, by themselves, do not convey any information, such as the preamble.

3.1.4 data rate [ITU-T G.9960]: The average number of bits communicated (transmitted) in a unit of time. The usual unit of time for data rate is 1 second.

3.1.5 DEVICE_ID [ITU-T G.9960]: A unique identifier allocated to a node operating in the domain by the domain master during registration.

3.1.6 domain ID [ITU-T G.9960]: A unique identifier of a domain.

3.1.7 domain master (DM) [ITU-T G.9960]: A node supporting the domain master functionality that manages (coordinates) all other nodes of the same domain (i.e., assigns bandwidth resources and manages priorities). Only one active domain master is allowed in a domain, and all nodes within a domain are managed (coordinated) by a single domain master.

3.1.8 inter-domain bridge [ITU-T G.9960]: A bridging function above the physical layer to interconnect nodes of two different domains.

3.1.9 logical (functional) interface [ITU-T G.9960]: An interface in which the semantic, syntactic, and symbolic attributes of information flows are defined. Logical interfaces do not define the physical properties of signals used to represent the information. It is defined by a set of primitives.

3.1.10 net data rate [ITU-T G.9960]: The data rate available at the A-interface of the transceiver reference model.

3.1.11 physical interface [ITU-T G.9960]: An interface defined in terms of physical properties of the signals used to represent the information transfer. A physical interface is defined by signal parameters such as power (power spectrum density), timing, and connector type.

3.1.12 primitives [ITU-T G.9960]: Basic measures of quantities obtained locally or reported by other nodes of the domain. Performance primitives are basic measurements of performance-related quantities, categorized as events, anomalies and defects. Primitives may also be basic measures of other quantities (e.g., a.c. or battery power).

3.1.13 priority [ITU-T G.9960]: A value assigned to the specific frame(s) that determines the relative importance of transmitting frame(s) during the upcoming opportunity to use the medium.

3.1.14 reference point [ITU-T G.9960]: A location in a signal flow, either logical or physical, that provides a common point for observation and/or measurement of the signal flow.

3.1.15 registration [ITU-T G.9960]: The process used by a node to join the domain.

3.1.16 relay node [ITU-T G.9960]: A node supporting relay functionality that acts as an intermediary node, through which other nodes of the same domain can pass their traffic (data, control, or management).

3.2 Terms defined in this Recommendation

This Recommendation defines the following terms:

3.2.1 alien domain: Any group of non-ITU-T G.9991 nodes connected to the same medium or which operate in close proximity.

3.2.2 asymmetrical full duplex transmission: A type of transmission where a node is transmitting to another node while it is receiving from a different node simultaneously.

3.2.3 bandplan: ~~A specific range of the frequency spectrum that is associated with a domain. The bandplans are confined to the modulation bandwidth of the optical source. Multiple bandplans may be used in the same domain provided that each bandplan used is a subset of the largest bandplan specified for the domain and a superset of the smallest bandplan specified for the domain. The bandplan is defined by a lower frequency and upper frequency reserved. This clause is intentionally left blank.~~

3.2.4 central node: The node that is transmitting to another node while receiving from a different node simultaneously of the asymmetrical full duplex transmission.

3.2.5 client: An application entity distinguished in the network by its unique address (e.g., MAC address).

3.2.6 domain: An ITU-T G.9991 network comprising the domain master and all those nodes that are registered with the same domain master. In the context of this Recommendation, use of the term "domain" without a qualifier means "ITU-T G.9991 domain". Additional qualifiers (e.g., "VLC") may be added to "domain".

3.2.7 downlink: A unidirectional link from the domain master to one or more end-point nodes. This term only applies to the domain operating in centralized mode.

3.2.8 end-point node: This term is used in this Recommendation according to the context to differentiate between the domain master node functionalities and non-domain master node functionalities.

3.2.9 global master (GM): A function that provides coordination between different domains, and which may also convey management functions initiated by the remote management system to support broadband access.

NOTE – Definition based on the one given in [ITU-T G.9960].

3.2.10 home network: A home network consists of one or more domains. In the context of this Recommendation, use of the term "home network" means "ITU-T G.9991 home network".

3.2.11 node: Any network device that contains an ITU-T G.9991 transceiver. In the context of this Recommendation, use of the term "node" without a qualifier means "ITU-T G.9991 node". Additional qualifiers (e.g., "relay") may be added to either "node".

3.2.11.1-operational frequency band (OFB): Range of frequencies that is allowed to be used by a node to communicate with another node of the domain.

3.2.11.2-OFB profile: Categorization of OFBs depending on the PHY frame format they use. Profile 1 OFBs use a normal PHY frame format for transmission of frames; Profile 2 OFBs use a high capacity header (HCH) PHY frame format for transmission of frames.

3.2.12 primary channel: The channel between the primary transmitter and the primary receiver of the full duplex transmission.

3.2.13 primary receiver: For an asymmetrical full duplex, the primary receiver is the node to which the central node transmits. For a symmetrical full duplex transmission, the primary receiver is the node that receives a request for the full duplex transmission.

- 3.2.14 primary transmission:** The transmission from the primary transmitter to the primary receiver.
- 3.2.15 primary transmitter:** For an asymmetrical full duplex transmission, the primary transmitter is the central node. For a symmetrical full duplex transmission, the primary transmitter is the node that requests to initiate the full duplex transmission.
- 3.2.16 secondary channel:** The channel between the secondary transmitter and the secondary receiver of the full duplex transmission.
- 3.2.17 secondary receiver:** For an asymmetrical full duplex transmission, the secondary receiver is the central node. For a symmetrical full duplex transmission, the secondary receiver is the node that requests to initiate the full duplex transmission, i.e., the primary transmitter.
- 3.2.18 secondary transmission:** The transmission from the secondary transmitter to the secondary receiver.
- 3.2.19 secondary transmitter:** For an asymmetrical full duplex transmission, the secondary transmitter is the node that transmits the MSG frame to the central node. For a symmetrical full duplex transmission, the secondary transmitter is the node that receives a request for the full duplex transmission, i.e., the primary receiver.
- 3.2.20 subcarrier index modulation:** For this modulation, the positions of used subcarriers in the frequency domain are utilized to transmit extra bits without additional power.
- 3.2.21 symmetrical full duplex transmission:** A type of transmission where a node is transmitting to another node while it is receiving from the same node simultaneously.
- 3.2.22 uplink:** A unidirectional link from an end-point node to the domain master. This term only applies to the domain operating in centralized mode.
- 3.2.23 wavelength band:** A specific range of the wavelength of light that is associated with a domain. Multiple wavelength bands may be used in the same domain. The wavelength band is defined by a lower wavelength and upper wavelength.

4 Abbreviations and acronyms

This Recommendation uses the following abbreviations and acronyms:

AAT	Address Association Table
ACO-OFDM	Asymmetrically Clipped Optical OFDM
AE	Application Entity
APC	Application Protocol Convergence
APDU	APC Protocol Data Unit
AR	Access Request
ARQ	Automatic Repeat request
ASC	Active Subcarrier
BAT	Bit Allocation Table
BER	Bit Error Rate
CBTS	Contention-Based TS
CFTS	Contention-Free TS
CFTXOP	Contention-Free TXOP
CM	Centralized Mode

CRC	Cyclic Redundancy Check
CRQ	Collision Resolution Queue
CRS	Carrier Sense
CW	Contention Window
DAP	Domain Access Point
DLL	Data Link Layer
DM	Domain Master
DME	DLL Management Entity
DMME	— Domain Master Management Entity
DQ	Distributed Queueing
DTQ	Data Transmission Queue
EHI	Extended Header Indication
EP	End Point
FDCFTXOP	Full Duplex Contention-Free TXOP
FDI	Full Duplex Indicator
FDSTXOP	Full Duplex Shared TXOP
FEC	Forward Error Correction
FT	Frame Type
GM	Global Master
GME	Global Master Entity
HAN	Home Area Network
IR	Infrared
ISC	Inactive Subcarrier
LAAT	Local Address Association Table
LCMP	Layer 2 Configuration and Management Protocol
LED	Light Emitting Diode
LLC	Logical Link Control
LCDU	link Control Data Unit
LPDU	LLC Protocol Data Unit
LPH	LPDU Header
LSB	Least Significant Bit
MAC	Medium Access Control
MPDU	MAC Protocol Data Unit
MAP	Medium Access Plan
MCS	Management, Control and Security
MDI	Medium-Dependent Interface
MIMO	Multiple Input/Multiple Output

MP2MP	Multipoint to Multipoint
MSB	Most Significant Bit
MSC	Masked Subcarrier
NME	Node Management Entity
NMS	Network Management System
OFDM	Orthogonal Frequency Division Multiplexing
P2MP	Point To Multipoint
P2P	Peer-To-Peer communication
PCS	Physical Coding Sub-layer
PD	Photodiode
PMA	Physical Medium Attachment
PMD	Physical Medium Dependent
PME	PHY Management Entity
PMI	Physical Medium-independent Interface
PMSC	Permanently Masked Subcarrier
PR	Priority Resolution
PSD	Power Spectral Density
QoS	Quality of Service
RG	Residential Gateway
RMSC	Regionally Masked Subcarrier
SC	Security Controller
SCE	Security Controller Entity
SIM	Subcarrier Index Modulation
SNR	Signal to Noise Ratio
SSC	Supported Subcarrier
STXOP	—— Shared TXOP
STW	Secondary Transmission Window
TCI	Transmission Channel Indicator
TS	Time Slot
TXOP	Transmission opportunity
UM	Unified Mode
VLC	Visible Light Communication

5 Conventions

5.1 Bit ordering convention

See clause 5.2.4 of [ITU-T G.9960].

6 System architecture and reference models

6.1 System architecture

An architectural model of the ITU-T G.9991 home network is shown in Figure 6-1. This model includes one or more domains and bridges to alien domains such as a PLC or Ethernet home network, or a DSL or PON access network. The global master function coordinates resources such as bandwidth reservations, inter-domain handover and operational characteristics between domains, and may convey the relevant functions initiated by a remote management system to support broadband access. Detailed specification and use of the global master function is specified in clause 6.1.4. The specification of bridges to alien domains and to the access network is beyond the scope of this Recommendation.

NOTE 1 – Depending on the application, domains could use any topology specified in clause 6.1.1.

NOTE 2 – It is possible to install multiple ITU-T G.9991 home networks (i.e., not connected by bridges to an alien domain) per dwelling.

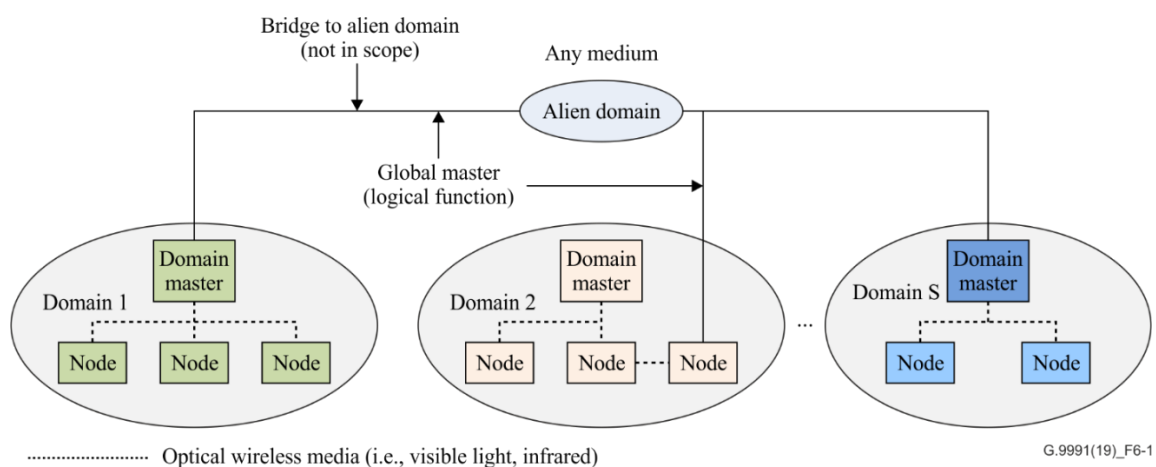

Figure 6-1 – ITU-T G.9991 home network architecture reference model

A domain comprises a domain master and may contain one or more nodes registered with it. Nodes in the same domain may connect through different media, i.e., visible light and infrared. The domain master considers bridges to alien domains as application entities (AEs) of a node with certain requirements.

6.1.1 Topology

While this specification does not preclude the use of ITU-T G.9991 in other topologies, it has been specifically designed to cope with the reference ones described in the following sections.

6.1.1.1 Peer to peer (or point to point) topology (P2P)

This topology is represented by Figure 6-2.

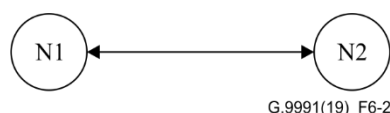

Figure 6-2 – P2P topology

In this topology one of the nodes will act as the domain master (DM) and the other as the end point (EP).

6.1.1.2 Point to multipoint topology (P2MP)

This topology, also known as "star" topology, is represented by Figure 6-3.

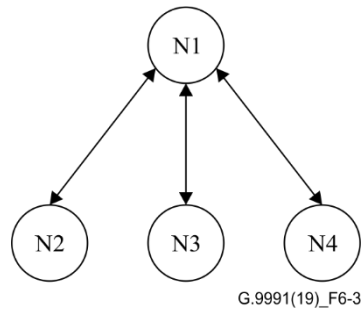

Figure 6-3 – P2MP topology

In this topology a node centralizes the communication. This node (usually the DM) is the only one authorized to exchange information with any node in the domain, and the other nodes cannot interact with each other. This is equivalent to the centralized mode (CM) of operation [ITU-T G.9960].

6.1.1.3 Multipoint to multipoint (MP2MP)

This topology, normally also called "mesh", is represented by Figure 6-4.

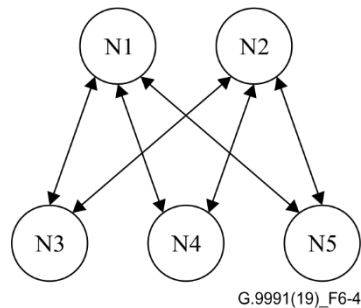

Figure 6-4 – MP2MP topology

In this topology nodes are authorized to talk between themselves; however, visibility may be limited. The MP2MP topology is for further study.

6.1.1.4 Relayed mode

This topology is represented by Figure 6-5.

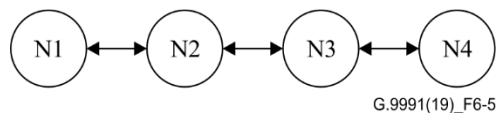

Figure 6-5 – Relayed topology

In this topology, intermediate nodes are used as relay nodes in order to link nodes without direct visibility.

Details of this mode are for further study.

6.1.1.5 Centralized topology

This topology is represented by Figure 6-6.

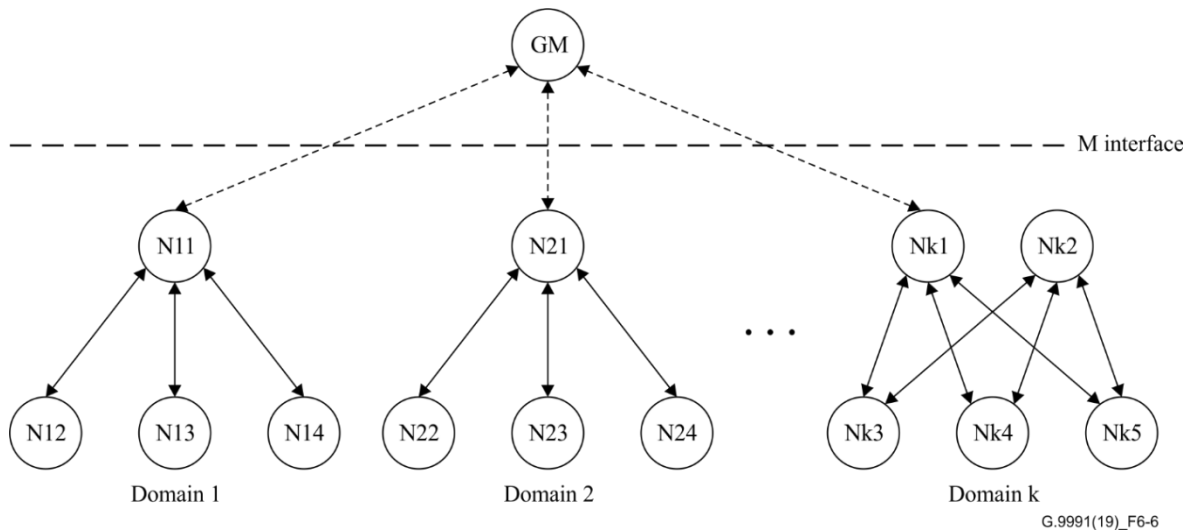

Figure 6-6 – Centralized topology

In this topology multiple domains operating in P2MP or MP2MP are coordinated by the same global master (see clause 6.1.3). There is no visibility between the nodes and the global master except for the case that the global master is co-located with a node.

6.1.2 Domains

6.1.2.1 General rules of operation

A domain, as depicted in Figure 6-1, may include nodes with a range of capabilities including extended capabilities such as relay and domain master. The function of the domain master is to assign and coordinate resources (bandwidth and priorities) of all nodes in its domain. The following rules apply for any domain:

- 1) A home network may include one or more domains.
- 2) More than one domain may be established over the same medium, for example, by using orthogonal signals over different frequency bands.
- 3) The home network shall have a unique name. All domains of the same home network shall use this name.
- 4) The domain ID shall be used to identify a specific domain. Each domain in a home network shall have a unique domain ID.
- 5) Domains from the same home network established over the same medium may interfere with each other (e.g., if they use the same frequency band). Coordination between domains of the same home network sharing a common medium may be performed.
- 6) All nodes in a domain shall be managed by a single domain master.
- 7) There shall be one and only one active domain master per domain.
- 8) Nodes are not required to be domain master capable. That is, some nodes may not support the functionality necessary to become a domain master.
- 9) The domain master shall assign a DEVICE_ID to a node during the node's registration process.

6.1.2.2 Relationship between domain and wavelength bands

Two wavelength bands are defined in this Recommendation, which are visible light (380 nm-780 nm) and infrared (800 nm-1675 nm). An ITU-T G.9991 domain can be up-converted to any one of the wavelength bands or both. Figure 6-7 shows an example of the relationships between domains and

wavelength bands. Domain A uses only visible light, Domain B uses only infrared, while Domain C uses both infrared and visible light.

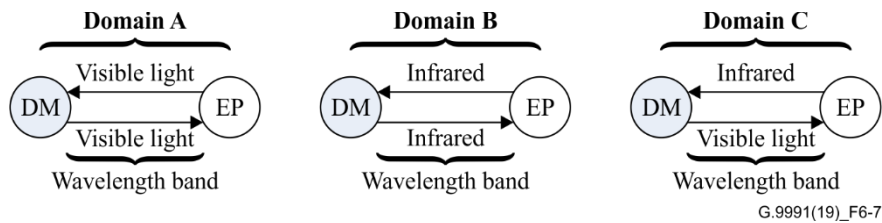

Figure 6-7 – Relationships between domain and medium

NOTE – Besides infrared and visible light, other media, e.g., RF may be used for uplink.

A node may be capable of supporting different wavelength bands. The capabilities of the transmitter and receiver to support different wavelength bands of a node are defined in Table 6-1.

Table 6-1 – Capabilities of the transceiver to support different wavelength bands

Transmitter capabilities	The node is only capable of transmitting visible light signals.
	The node is only capable of transmitting infrared signals.
	The node is capable of transmitting both visible light and infrared signals.
Receiver capabilities	The node is only capable of receiving visible light signals.
	The node is only capable of receiving infrared signals.
	The node is capable of receiving both visible light and infrared signals using a single photodiode (PD).
	The node is capable of receiving both visible light and infrared signals using different PDs.

A domain may include multiple classes of nodes that support different wavelength bands. A node can only communicate with another node when they use matched wavelength bands. A node can only join a domain when it supports the capability to receive signals from the domain master or a relay-capable node; meanwhile, the domain master and the relay-capable node shall also support the capability to receive signals from the node.

6.1.2.3 Modes of operation

A domain can operate in one of two modes: centralized mode (CM) or unified mode (UM). Different domains within the home network can use different modes of operation, i.e., CM or UM. Broadcast and multicast shall be supported in any domain, independent of their operational mode (CM or UM).

In CM the domain master can communicate with any end-point node in the domain directly while direct communication between end-point nodes are not allowed. The end-point nodes may communicate with each other through the domain master. A domain operating in CM may support bidirectional communication, broadcast-only (i.e., unidirectional link) and hybrid communication (e.g., using RF for uplink). Figure 6-8 shows the use of CM.

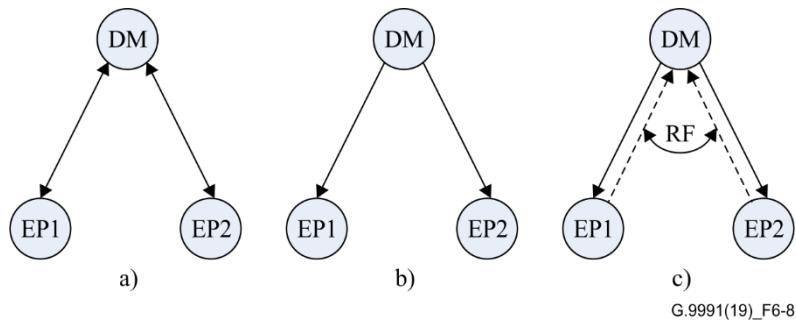

Figure 6-8 – Domain operating in centralized mode (CM)

NOTE – Regarding the bidirectional communication, the transmitter and receiver may use different frequency bands (e.g., visible light communication (VLC) and infrared (IR)).

In UM any node can communicate with another node directly or indirectly, via other nodes operating as relay nodes. Figure 6-9 shows the use of UM. In the example, the EP3 and DM that are hidden from each other communicate with each other via the relay node (EP2).

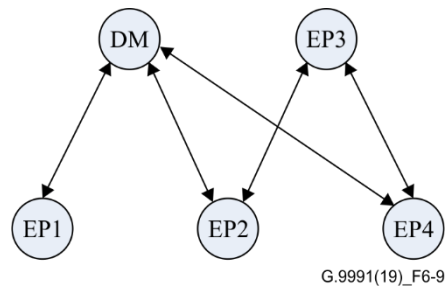

Figure 6-9 – Domain operating in unified mode (UM)

Details on UM are for further study.

6.1.3 Node functionality

The main functions and capabilities of a node are summarized in Table 6-2.

Table 6-2 – Main functions and capabilities of a node

Function	Description and parameters
Medium access	Receives, interprets and acts upon the medium access plan (MAP)
Support of admission control protocol	Supports admission control protocol
Support of operational modes of the domain	Supports the operational mode (CM or UM) used by the domain Complies with spectrum compatibility settings for the domain
Support of medium access rules	Accesses medium using medium access rules coordinated with the domain master
Support of security	Supports authentication and encryption key management procedures
Collection and reporting of node information	Provides statistics: <ul style="list-style-type: none"> – list of visible nodes – list of addresses (AAT) – list of capabilities supported by the node – performance statistics (data rate, error count, time stamps).

Table 6-2 – Main functions and capabilities of a node

Function	Description and parameters
Request of bandwidth allocation	<ul style="list-style-type: none"> – Performs flow set up – Requests bandwidth allocations from the domain master in order to meet QoS requirements of flows
Support of retransmissions	Provides acknowledgment and retransmission of data units that were received with error
Support of extended capabilities	<ul style="list-style-type: none"> – Domain master – Domain access point (DAP) – Domain master selection procedure – Security controller (SC)
Support of management	Support node management
Support of power saving modes	Support of optional power saving modes: L1, L2, L3, L4

6.1.3.1 Domain master functionality

A domain master controls operation of the nodes in the domain. In addition to the node functionality in Table 6-2, the main functions and capabilities of CM and UM domain masters are summarized in Table 6-3 and Table 6-4, respectively.

Table 6-3 – Main functions and capabilities of a domain master in CM

Function	Description and parameters
Indication of presence	Periodically communicates MAP to all nodes in the domain
Admission control	Admits new nodes to the domain Limits the number of nodes in a domain Facilitates departure of nodes from the domain
Determination of domain operation	Signals the operational mode inside the domain. Facilitates spectrum compatibility for the domain by assigning relevant limits on: <ul style="list-style-type: none"> – frequency band – total transmit power (see clause 8.2.4) – PSD mask.
Bandwidth allocation and QoS support	Assigns medium access rules to all nodes of the domain to facilitate support of QoS
Monitor status of the domain	Collects statistics of domain operation: <ul style="list-style-type: none"> – list of nodes in the domain – topology – performance statistics (data rate, error count).
Communication with the global master (for further study)	Coordinates operation of the domain with other domains using the global master function
Support of management	Support domain master management
Support of power saving modes	Support of power saving modes: L1, L2, L3 and L4

Table 6-4 – Main functions and capabilities of a domain master in UM mode

Function	Description and parameters
Indication of presence	Periodically communicates MAP to all nodes in the domain
Admission control	Admits new nodes to the domain Limits the number of nodes in a domain Facilitates departure of nodes from the domain
Determination of domain operation	Signals the operational mode inside the domain Supports hidden nodes by assigning MAP repeaters Facilitates spectrum compatibility for the domain by assigning relevant limits on: <ul style="list-style-type: none"> – frequency band – total transmit power (see clause 8.2.4) – PSD mask.
Bandwidth allocation and QoS support	Assigns medium access rules to all nodes of the domain to facilitate support of QoS
Monitor status of the domain	Collects statistics of domain operation: <ul style="list-style-type: none"> – list of nodes in the domain – topology – performance statistics (data rate, error count).
Communication with the global master (for further study)	Coordinates operation of the domain with other domains using the global master function
Backup master assignment	Assigning of a backup domain master to take over the domain master role
Support of management	Support domain master management
Support of power saving modes	Support of power saving modes: L1, L2, L3 and L4

6.1.4 Global master function

See clause 5.1.3 of [ITU-T G.9961].

6.2 Reference models**6.2.1 Protocol reference model of a VLC system**

The reference model used for ITU-T G.9991 follows the structure presented in clause 5.2.1 of [ITU-T G.9960].

Due to the adaptation of ITU-T G.9991 technology to different scenarios, different PHY layers are defined in this Recommendation. However, the DLL layer is common for all devices compliant with this Recommendation.

A device is compliant with this Recommendation if it implements the common DLL layer and at least one of the PHY layers described in this Recommendation.

All the different PHY layers described in this Recommendation are compliant to the PMI interface description described in clause 5.2.2.2 of [ITU-T G.9960].

Figure 6-10 shows the ITU-T G.9991 protocol reference model.

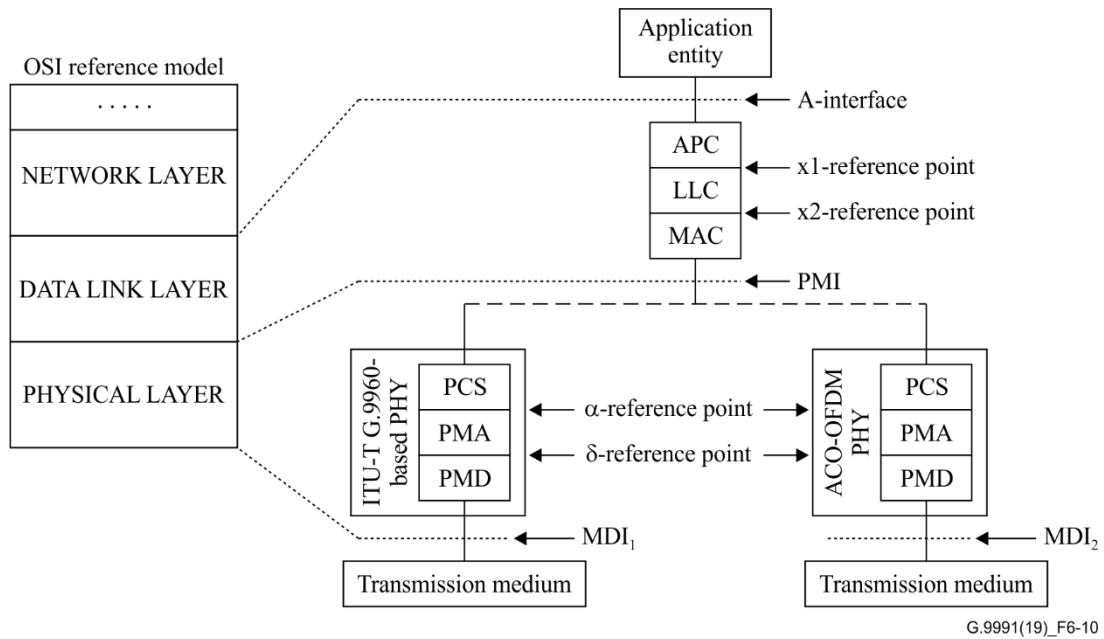

Figure 6-10 – Reference model

6.2.2 Interfaces – functional description

See clause 5.2.2 of [ITU-T G.9960].

6.2.2.1 A-interface

See clause 5.2.2.1 of [ITU-T G.9960].

6.2.2.2 Physical medium-independent interface (PMI)

See clause 5.2.2.2 of [ITU-T G.9960].

6.2.2.3 Medium-dependent interface (MDI)

Functional characteristics of the MDI are described by two signal flows:

- transmit signal (TX DATA) is the flow of frames transmitted on to the medium;
- receive signal (RX DATA) is the flow of frames received from the medium.

The implementation of these two primitives can be different depending on the physical layer used by the VLC device.

6.2.3 Functional model of a VLC transceiver

The functional model of a VLC transceiver is presented in Figure 6-11. It addresses nodes without extended capabilities, as well as nodes with extended capabilities such as domain master and relaying (including DAP), which differ by their medium access control (MAC), logical link control (LLC) and upper layer functionalities.

The PHY layer function is dependent on the physical layer implementation but includes all functions necessary to encapsulate MPDUs into PHY frames (e.g, flow control, encapsulation, line coding, etc.).

Clause 8 of this Recommendation describes the adaptation of an [ITU-T G.9960] PHY layer to the VLC system. Clause 9 of this Recommendation describes a PHY layer based on an asymmetrically clipped optical (ACO-OFDM) approach.

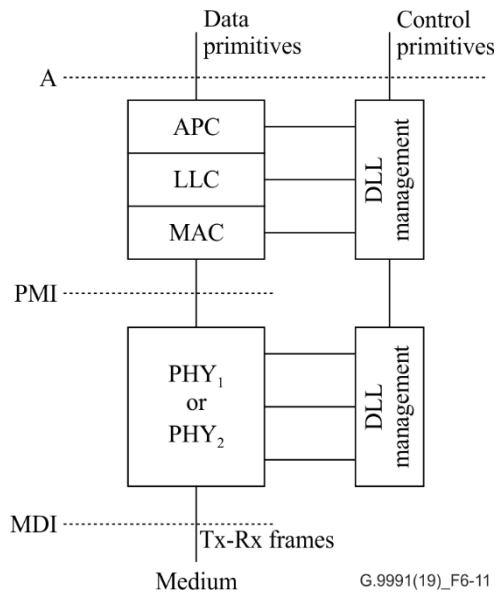

Figure 6-11 – Functional model of a VLC transceiver

The detailed description of the functional model of the DLL is specified in clause 10.

6.3 Management-plane model of a VLC system

Figure 6-12 illustrates data, control and management-plane reference models for an ITU-T G.9991 transceiver. Details of data and control-plane reference models are shown in clause 6.2. The Q-interface provides the interface between the network management systems (NMS) and the node management entity (NME) at a node. The definition of parameters at the Q-interface and the transport of the management instrumentation over the Q-interface are outside the scope of this Recommendation. The X-interface provides the interface between the external dimmer function and the NME.

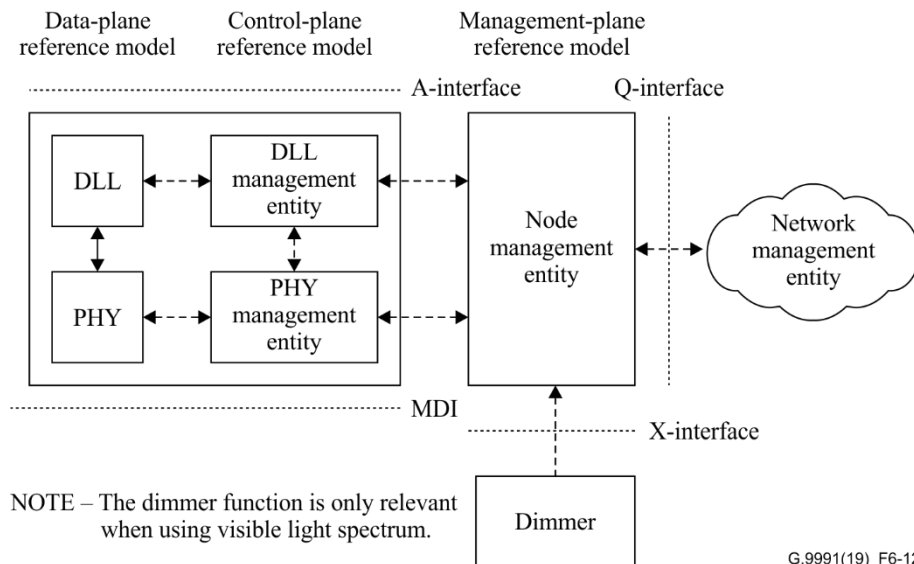

Figure 6-12 – Management-plane reference model

7 Topology profiles

Topology profiles are intended to specify nodes with significantly different levels of complexity and functionality. A node shall be classified into particular topology profiles according to its degree of

complexity and functionality. For compliance with this Recommendation, a node is required to support one topology profile, at a minimum.

7.1 Topology profiles based on the operational modes

Based on the operational modes (see clause 6.1.2.3), a node shall be classified into two topology profiles: centralized-mode (CM) topology profile and unified-mode (UM) topology profile. A node shall support at least one topology profile.

A node that supports only CM topology profile is not allowed to be a member of the domain operating in unified mode, while a node that supports only UM topology profile is not allowed to be a member of the domain operating in centralized mode.

8 Physical layer specification I (PHY layer based on ITU-T G.9960)

8.1 Medium independent specification

8.1.1 Functional model of the PHY

See clause 7.1.1 of [ITU-T G.9960].

8.1.2 Physical coding sublayer (PCS)

See clause 7.1.2 of [ITU-T G.9960].

8.1.2.1 PHY frame

See clause 7.1.2.1 of [ITU-T G.9960].

8.1.2.2 MPDU mapping

See clause 7.1.2.2 of [ITU-T G.9960].

8.1.2.3 PHY frame header

See clause 7.1.2.3 of [ITU-T G.9960].

8.1.2.3.1 Common part fields

8.1.2.3.1.1 Frame type (FT)

The frame type (FT) field is a 4-bit field that indicates the type of PHY frame.

Table 8-1 describes the PHY-frame types.

Table 8-1 – PHY-frame types

Type	Value (b ₃ b ₂ b ₁ b ₀)	Description	Reference
MAP/RMAP	0000	MAP/RMAP frame	Clause 8.1.2.3.2.1
MSG	0001	Data and management frame	Clause 8.1.2.3.2.2
ACK	0010	ACK control frame	Clause 8.1.2.3.2.3
RTS	0011	RTS control frame	Clause 8.1.2.3.2.4
CTS	0100	CTS control frame	Clause 8.1.2.3.2.5
CTMG	0101	Short control frame	Clause 8.1.2.3.2.6
PROBE	0110	PROBE frame	Clause 8.1.2.3.2.7
ACKRQ	0111	ACK retransmission request frame	Clause 8.1.2.3.2.8

Table 8-1 – PHY-frame types

Type	Value (b ₃ b ₂ b ₁ b ₀)	Description	Reference
BMSG	1000	Bidirectional MSG frame; contains data and management frames in the payload and ACK	Clause 8.1.2.3.2.9
BACK	1001	Bidirectional ACK frame; contains ACK and data and management frames in the payload	Clause 8.1.2.3.2.10
ACTMG	1010	Acknowledgment for CTMG frame	Clause 8.1.2.3.2.11
IND	1011	Indication frame for distributed queueing (DQ) based contention access mechanism for half duplex MAC	Clause 8.1.2.3.2.12
Reserved	1100 to 1110	Reserved by ITU-T	Clause 8.1.2.3.2.13 to Clause 8.1.2.3.2.15
FTE	1111	Frame type extension; this frame type is a pointer to a set of additional frame types.	Clause 8.1.2.3.2.16

8.1.2.3.1.2 Domain ID (DOD)

See clause 7.1.2.3.1.2 of [ITU-T G.9960].

8.1.2.3.1.3 Source ID (SID)

See clause 7.1.2.3.1.3 of [ITU-T G.9960].

8.1.2.3.1.4 Destination ID (DID)

See clause 7.1.2.3.1.4 of [ITU-T G.9960].

8.1.2.3.1.5 Multicast indication (MI)

See clause 7.1.2.3.1.5 of [ITU-T G.9960].

8.1.2.3.1.6 Duration indication (DRI)

See clause 7.1.2.3.1.6 of [ITU-T G.9960].

8.1.2.3.1.7 Extended header indication (EHI)

If the EHI field is set to one, the PHY frame header shall contain $2 \times \text{PHY}_H$ information bits. The additional PHY_H information bits of the extended part of the PHY-frame header are specified in clause 8.1.2.3.3. If the EHI field is set to zero, the PHY-frame header shall contain PHY_H information bits. The EHI field shall be set according to the frame type as shown in Table 8-2.

Table 8-2 – Value of EHI for different frame types

Frame type	Value of EHI
MAP/RMAP	zero
MSG	zero or one
ACK	zero or one
RTS	zero
CTS	zero

Table 8-2 – Value of EHI for different frame types

Frame type	Value of EHI
PROBE	zero
ACKRQ	zero
BMSG	zero or one
BACK	zero or one
CTMG	zero or one
FTE	zero or one
ACTMG	zero
IND	zero

8.1.2.3.1.8 Header segmentation indication (HSI)

See clause 7.1.2.3.1.8 of [ITU-T G.9960].

8.1.2.3.1.9 Header check sequence (HCS)

See clause 7.1.2.3.1.9 of [ITU-T G.9960].

8.1.2.3.2 Variable part fields

See clause 7.1.2.3.2 of [ITU-T G.9960].

8.1.2.3.2.1 MAP and RMAP PHY-frame type specific fields

See clause 7.1.2.3.2.1 of [ITU-T G.9960].

8.1.2.3.2.2 MSG PHY-frame type specific fields

Table 8-3 lists the PHY-frame header fields specific to the MSG frame type.

Table 8-3 – MSG PHY-frame type specific fields

Field	Octet	Bits	Description	Reference
MSG_DUR	0 and 1	[15:0]	Duration for MSG frame	Clause 8.1.2.3.2.2.1
BLKSZ	2	[1:0]	Block size of FEC codeword for MSG frame payload	Clause 8.1.2.3.2.2.2
FEC_RATE		[4:2]	FEC coding rate for MSG frame payload	Clause 8.1.2.3.2.2.3
REP		[7:5]	Number of repetitions used for encoding the MSG frame payload	Clause 8.1.2.3.2.2.4
FCF	3	[2:0]	FEC concatenation factor	Clause 8.1.2.3.2.2.5
SI		[6:3]	Scrambler initialization	Clause 8.1.2.3.2.2.6
MDET		[7]	Master is detected	Clause 8.1.2.3.2.2.7
BAT_ID	4	[4:0]	Bit allocation table identifier	Clause 8.1.2.3.2.2.8
BNDPLOBFB _ID/GRP_ID		[7:5]	Bandplan-OFB identifier/subcarrier grouping identifier	Clause 8.1.2.3.2.2.9
GI_ID	5	[2:0]	Guard interval identifier	Clause 8.1.2.3.2.2.10

Table 8-3 – MSG PHY-frame type specific fields

Field	Octet	Bits	Description	Reference
APSD <u>MAX</u> -M		[7:3]	<u>APSD MAX-M of A</u> actual PSD ceiling of MSG frame	Clause 8.1.2.3.2.2.11
CONNECTION_ID	6	[7:0]	Connection identifier	Clause 8.1.2.3.2.2.12
RPRQ	7	[1:0]	Reply required	Clause 8.1.2.3.2.2.13
BRSTCnt		[3:2]	Burst frame count	Clause 8.1.2.3.2.2.14
BEF		[4]	Burst end flag	Clause 8.1.2.3.2.2.15
AIFG_IND		[5]	AIFG indication	Clause 8.1.2.3.2.2.16
Reserved		[6]	Reserved	Reserved for use by ITU-T G.9963
Reserved		[7]	Reserved	Reserved by ITU-T (Note 1)
ACE_SYM	8	[2:0]	Number of ACE symbols	Clause 8.1.2.3.2.2.18
CNN_MNGMT		[6:3]	Connection management	Clause 8.1.2.3.2.2.19
Reserved		[7]	Reserved	Reserved by ITU-T (Note 1)
BRURQ	9 and 10	[15:0]	Bandwidth reservation update request	Clause 8.1.2.3.2.2.20 (Note 2)
START_SSN	9 and 10	[15:0]	Start segment sequence number	Clause 8.1.2.3.2.2.21 (Note 3)
CURRTS	11	[6:0]	Current TS	Clause 8.1.2.3.2.2.22
BTXRQ		[7]	Request for bidirectional transmission	Clause 8.1.2.3.2.2.23
NUM_MACK_SLOTS	12	[2:0]	Number of Mc-ACK slots	Clause 8.1.2.3.2.2.24
ADVISED_WIN_SIZE		[7:3]	In connection establishment this field may specify advised window size.	Clause 8.1.2.3.2.2.25 (Note 4)
FDI	13	[0]	Full duplex indication	Clause 8.1.2.3.2.2.17
Reserved		[7:1]	Reserved	Reserved by ITU-T (Note 1)
Reserved	14	[7:0]	Reserved	Reserved by ITU-T (Note 1)

NOTE 1 – Bits that are reserved by ITU-T shall be set to zero by the transmitter and ignored by the receiver.
NOTE 2 – The BRURQ field is defined when the START_SSN field is not defined (see Note 3).
NOTE 3 – The START_SSN field is defined only when CNN_MNGMT = 0001, CNN_MNGMT = 0011, CNN_MNGMT = 0101 or CNN_MNGMT = 0111. Otherwise, the meaning of this field is BRURQ.
NOTE 4 – The ADVISED_WIN_SIZE field is defined only when CNN_MNGMT = 0101, otherwise these bits are reserved by ITU-T and shall be set to zero by the transmitter and ignored by the receiver.

8.1.2.3.2.2.1 Duration for MSG frame (MSG_DUR)

See clause 7.1.2.3.2.2.1 of [ITU-T G.9960].

8.1.2.3.2.2.2 Block size (BLKSZ)

See clause 7.1.2.3.2.2.2 of [ITU-T G.9960].

8.1.2.3.2.2.3 FEC coding rate (FEC_RATE)

See clause 7.1.2.3.2.2.3 of [ITU-T G.9960].

8.1.2.3.2.2.4 Repetitions (REP)

See clause 7.1.2.3.2.2.4 of [ITU-T G.9960].

8.1.2.3.2.2.5 FEC concatenation factor (FCF)

See clause 7.1.2.3.2.2.5 of [ITU-T G.9960].

8.1.2.3.2.2.6 Scrambler initialization (SI)

See clause 7.1.2.3.2.2.6 of [ITU-T G.9960].

8.1.2.3.2.2.7 Master is detected indication (MDET)

See clause 7.1.2.3.2.2.7 of [ITU-T G.9960].

8.1.2.3.2.2.8 Bit allocation table identifier (BAT_ID)

See clause 7.1.2.3.2.2.8 of [ITU-T G.9960].

8.1.2.3.2.2.9 ~~Bandplan-OFB~~ identifier/subcarrier grouping identifier (~~BNDPLOFB_ID~~/GRP_ID)

See clause 7.1.2.3.2.2.9 of [ITU-T G.9960].

8.1.2.3.2.2.10 Guard interval identifier (GI_ID)

See clause 7.1.2.3.2.2.10 of [ITU-T G.9960].

8.1.2.3.2.2.11 Maximum actual PSD of MSG frame (APSD_MAX-M)~~Actual PSD ceiling of MSG frame (APSDC-M)~~

See clause 7.1.2.3.2.2.11 of [ITU-T G.9960].

8.1.2.3.2.2.12 Connection identifier (CONNECTION_ID)

See clause 7.1.2.3.2.2.12 of [ITU-T G.9960].

8.1.2.3.2.2.13 Reply required (RPRQ)

See clause 7.1.2.3.2.2.13 of [ITU-T G.9960].

8.1.2.3.2.2.14 Burst frame count (BRSTCnt)

See clause 7.1.2.3.2.2.14 of [ITU-T G.9960].

8.1.2.3.2.2.15 Burst end flag (BEF)

See clause 7.1.2.3.2.2.15 of [ITU-T G.9960].

8.1.2.3.2.2.16 AIFG indication (AIFG_IND)

See clause 7.1.2.3.2.2.16 of [ITU-T G.9960].

8.1.2.3.2.2.17 Full duplex indicator (FDI)

The FDI field shall indicate whether the frame header of this MSG frame contains the secondary transmission information. If the 'FDI' bit is set to one, the extended frame header of the MSG frame shall contain the secondary transmission information. The 'FDI' bit in the frame header of the MSG frames belonging to the primary transmission of the full duplex transmission in the FDSTXOP shall be set to one.

8.1.2.3.2.2.18 ACE symbols (ACE_SYM)

See clause 7.1.2.3.2.2.17 of [ITU-T G.9960].

8.1.2.3.2.2.19 Connection management (CNN_MNGMT)

See clause 7.1.2.3.2.2.18 of [ITU-T G.9960].

8.1.2.3.2.2.20 Bandwidth reservation update request (BRURQ)

See clause 7.1.2.3.2.2.19 of [ITU-T G.9960].

8.1.2.3.2.2.21 Start segment sequence number (START_SSN)

See clause 7.1.2.3.2.2.20 of [ITU-T G.9960].

8.1.2.3.2.2.22 Current TS (CURRTS)

See clause 7.1.2.3.2.2.21 of [ITU-T G.9960].

8.1.2.3.2.2.23 Request for bidirectional transmission (BTXRQ)

See clause 7.1.2.3.2.2.22 of [ITU-T G.9960].

8.1.2.3.2.2.24 Number of Mc-ACK slots (NUM_MCACK_SLOTS)

See clause 7.1.2.3.2.2.23 of [ITU-T G.9960].

8.1.2.3.2.2.25 Advised Window Size (ADVISED_WIN_SIZE)

See clause 7.1.2.3.2.2.24 of [ITU-T G.9960].

8.1.2.3.2.3 ACK PHY-frame type specific fields

Table 8-4 lists the PHY-frame header fields specific to the core part of the PHY-frame header of the ACK frame type.

Table 8-4 – ACK PHY frame type specific fields

Field	Octet	Bits	Description	Reference
FLCTRL_CONN	0	[0]	Flow control connection flag	Clause 8.1.2.3.2.3.1
FLCTRLT		[1]	Flow control type	Clause 8.1.2.3.2.3.2
FLCTRL		[6:2]	Flow control	Clause 8.1.2.3.2.3.3
FLCTRL_EXT		[7]	Flow control extension	Clause 8.1.2.3.2.3.14
RXRST_DATA	1	[0]	Data RX reset flag	Clause 8.1.2.3.2.3.5
RXRST_MNGMT		[1]	Management RX reset flag	Clause 8.1.2.3.2.3.6
BAD_BURST		[2]	Bad burst indication	Clause 8.1.2.3.2.3.7
BTXRQ		[3]	Request for bidirectional transmission	Clause 8.1.2.3.2.3.4
EXTACKRQ		[4]	Request for extended acknowledgement	Clause 8.1.2.3.2.3.13
FDI		[6:5]	Full duplex indicator	Clause 8.1.2.3.2.3.8
TCI		[7]	Transmission channel indicator, has applicable information only if the 'FDI' field is set to '10'.	Clause 8.1.2.3.2.3.9

Table 8-4 – ACK PHY frame type specific fields

Field	Octet	Bits	Description	Reference
ACK_CE_CTRL/ RX_CONN_WIN_SIZE	2	[6:0]	ACK channel estimation control/Receiver window size for the connection. (Note 1)	Clause 8.1.2.3.2.3.10
Reserved		[7]	Reserved	Reserved for use by ITU-T G.9963
ACKDATA/MACK_D	3 to 14	[90:0]	Acknowledgement data and Mc-ACK descriptor	Clause 8.1.2.3.2.3.11
CRQLength		[94:91]	The length of the CRQ	Clause 8.1.2.3.2.3.12
Reserved		[95]	Reserved	Reserved by ITU-T (Note 2)
NOTE 1 – This field is interpreted as RX_CONN_WIN_SIZE only when the ACK frame is sent as a reply for an MSG frame requesting the set-up of either a data or a management connection (i.e., when CNN_MNGMT in the MSG frame for connection set-up is 0101 ₂ or 0001 ₂).				
NOTE 2 – Bits that are reserved by ITU-T shall be set to zero by the transmitter and ignored by the receiver.				

8.1.2.3.2.3.1 Flow control connection flag (FLCTRL_CONN)

See clause 7.1.2.3.2.3.1 of [ITU-T G.9960].

8.1.2.3.2.3.2 Flow control type (FLCTRLT)

See clause 7.1.2.3.2.3.2 of [ITU-T G.9960].

8.1.2.3.2.3.3 Flow control (FLCTRL)

See clause 7.1.2.3.2.3.3 of [ITU-T G.9960].

8.1.2.3.2.3.4 Request for bidirectional transmission (BTRXQ)

See clause 7.1.2.3.2.3.4 of [ITU-T G.9960].

8.1.2.3.2.3.5 Data RX reset flag (RXRST_DATA)

See clause 7.1.2.3.2.3.5 of [ITU-T G.9960].

8.1.2.3.2.3.6 Management RX reset flag (RXRST_MNGMT)

See clause 7.1.2.3.2.3.6 of [ITU-T G.9960].

8.1.2.3.2.3.7 Bad burst indication (BAD_BURST)

See clause 7.1.2.3.2.3.7 of [ITU-T G.9960].

8.1.2.3.2.3.8 Full duplex indicator (FDI)

The FDI field shall indicate whether the frame is an ACK frame that includes the feedback notification for the full duplex transmission in FDSTXOP, or an ACK frame for the half duplex transmission in the CBTXOP as described in clause 10.2.2.3.8, or a regular ACK frame without extra indication. It is a 2-bit field that shall be coded as shown in Table 8-5.

Table 8-5 – Interpretation of the FDI field

FDI value (b ₆ b ₅)	Interpretation
00	The ACK frame is a regular ACK frame without extra indication.
01	The feedback notification for the full duplex transmission in the FDSTXOP shall be encapsulated in the frame header of the ACK frame, and the acknowledgement data in the ACK frame shall be the acknowledgement to the MSG frame sent by the secondary transmitter identified by the 'HeadDTQ' on the transmission channel in the STW.
10	The frame is an ACK frame for the half duplex transmission in a CBTXOP (see clause 10.2.2.3.8), and the acknowledgement data in the ACK frame shall be the acknowledgement to the MSG frame sent by the node identified by the 'HeadDTQ' on the transmission channel
11	Reserved by ITU-T

If the FDI field is set to '01', the 'ACKDATA' field in the ACK frame shall indicate the reception status of the MSG frame sent on the transmission channel in the STW. If the FDI field is set to '10', the 'ACKDATA' field in the ACK frame shall indicate the reception status of the MSG frame sent on the transmission channel if there is a transmission channel in the STW.

8.1.2.3.2.3.9 Transmission channel indicator (TCI)

The TCI field shall indicate whether the next TS shall contain a transmission channel or not. If this field is set to one, the next TS shall contain a transmission channel after the access channel; otherwise, if this field is set to zero, the next TS shall not contain a transmission channel.

This field has applicable information only when the 'FDI' field is set to '10'.

8.1.2.3.2.3.10 ACK channel estimation control/Receiver window size for the connection (ACK_CE_CTRL/RX_CONN_WIN_SIZE)

See clause 7.1.2.3.2.3.8 of [ITU-T G.9960].

8.1.2.3.2.3.11 Acknowledgement data and Mc-ACK descriptor (ACKDATA/MACK_D)

See clause 7.1.2.3.2.3.9 of [ITU-T G.9960].

8.1.2.3.2.3.12 CRQ length (CRQLength)

The 'CRQLength' field shall indicate the value of the length of the CRQ, which is the number of collisions left to be resolved. One collision corresponds to one contention slot where at least two candidate secondary transmitters have sent their ARs and the collision has not been resolved yet. It shall be represented as a 4-bit unsigned integer with valid values in the range from 0 to 15. When calculating the length of the CRQ, the collisions newly occurred in the current STW have been taken into account.

8.1.2.3.2.3.13 Extended ACK Requested (EXTACKRQ)

See clause 7.1.2.3.2.3.10 of [ITU-T G.9960].

8.1.2.3.2.3.14 Flow control extension (FLCTRL_EXT)

See clause 7.1.2.3.2.3.11 of [ITU-T G.9960].

8.1.2.3.2.4 RTS PHY-frame type specific fields

Table 8-6 lists the PHY-frame header fields specific to the RTS frame type.

Table 8-6 – RTS PHY-frame type specific fields

Field	Octet	Bits	Description	Reference
RTS_DUR	0 and 1	[15:0]	Duration for RTS frame	Clause 8.1.2.3.2.4.1
CID	2	[7:0]	CTS proxy ID	Clause 8.1.2.3.2.4.2
CURRTS	3	[6:0]	Current TS	Clause 8.1.2.3.2.4.3
Reserved		[7]	Reserved	Reserved by ITU-T (Note)
FDI	4	[1:0]	Full duplex indicator.	Clause 8.1.2.3.2.4.4
Reserved		[7:2]	Reserved	Reserved by ITU-T (Note)
Reserved	5 to 14	[87:0]	Reserved	Reserved by ITU-T (Note)

NOTE – Bits that are reserved by ITU-T shall be set to zero by the transmitter and ignored by the receiver.

8.1.2.3.2.4.1 Duration for RTS frame (RTS_DUR)

See clause 7.1.2.3.2.4.1 of [ITU-T G.9960].

8.1.2.3.2.4.2 CTS proxy ID (CID)

See clause 7.1.2.3.2.4.2 of [ITU-T G.9960].

8.1.2.3.2.4.3 Current TS (CURRTS)

See clause 7.1.2.3.2.4.3 of [ITU-T G.9960].

8.1.2.3.2.4.4 Full duplex Indicator (FDI)

The FDI field shall indicate whether this RTS frame is an AR frame in the case of the full duplex transmission in the FDSTXOP, or an AR frame for the half duplex transmission in the CBTXOP as described in clause 10.2.2.3.8, or is a regular RTS frame. It is a 2-bit field that shall be coded as shown in Table 8-7.

Table 8-7 – Interpretation of the FDI field

FDI value (b ₁ b ₀)	Interpretation
00	The RTS frame is a regular RTS frame
01	The RTS is an access request (AR) frame for full duplex transmission in the FDSTXOP
10	The RTS is an access request (AR) frame for transmission in the CBTXOP
11	Reserved by ITU-T

8.1.2.3.2.5 CTS PHY-frame type specific fields

See clause ~~7~~8.1.2.3.2.5 of [ITU-T G.9960].

8.1.2.3.2.6 CTMG PHY-frame type specific fields

See clause 7.1.2.3.2.6 of [ITU-T G.9960].

8.1.2.3.2.7 PROBE PHY-frame type specific fields

See clause 7.1.2.3.2.7 of [ITU-T G.9960].

8.1.2.3.2.8 ACKRQ PHY frame type specific fields

See clause 7.1.2.3.2.8 of [ITU-T G.9960].

8.1.2.3.2.9 BMSG PHY-frame type specific fields

See clause 7.1.2.3.2.9 of [ITU-T G.9960].

8.1.2.3.2.10 BACK PHY-frame type specific fields

See clause 7.1.2.3.2.10 of [ITU-T G.9960].

8.1.2.3.2.11 ACTMG PHY-frame type specific fields

See clause 7.1.2.3.2.11 of [ITU-T G.9960].

8.1.2.3.2.12 IND PHY-frame type specific fields

Table 8-9 lists the PHY-frame header specific fields to the core part of the PHY-frame header of the IND frame type.

Table 8-8 – IND PHY-frame type specific fields

Field	Octet	Bits	Description	Reference
Node [0]	0	[7:0]	The DEVICE_ID of the node that has sent an AR that has been received successfully by the central node in contention slot 1 of the access channel. (Note 1).	Clause 8.1.2.3.2.12.1
Node[1]	1	[7:0]	The DEVICE_ID of the node that has sent an AR that has been received successfully by the central node in contention slot 2 of the access channel. (Note 1).	Clause 8.1.2.3.2.12.1
Node [2]	2	[7:0]	The DEVICE_ID of the node that has sent an AR that has been received successfully by the central node in contention slot 3 of the access channel. (Note 1).	Clause 8.1.2.3.2.12.1
Reserved	3 and 14	[95:0]	Reserved	Reserved by ITU-T (Note 2)
NOTE 1 – This field shall be ignored if contention slot i of the access channel is not indicated as "successful" in the ACK frame.				
NOTE 2 – Bits that are reserved by ITU-T shall be set to zero by the transmitter and ignored by the receiver.				

8.1.2.3.2.12.1 Node [i]

The Node [i] (i= 1, 2, 3) field shall indicate the DEVICE_ID of the node which has sent an AR that has been received successfully by the DM in the contention slot i of the access channel when the DQ-based contention access mechanism specified in clause 10.2.2.3.8 is implemented in a CBTXOP. If contention slot i is indicated as "idle" or "collision" by the DM, Node [i] field in the IND frame shall be set to 0xFF and be ignored by the receiver.

8.1.2.3.2.13 Reserved

Reserved by ITU-T.

8.1.2.3.2.14 Reserved

Reserved by ITU-T.

8.1.2.3.2.15 Reserved

Reserved by ITU-T.

8.1.2.3.2.16 FTE PHY-frame type specific fields

See clause 8.1.2.3.2.16 of [ITU-T G.9960].

8.1.2.3.3 Extended header fields

See clause 7.1.2.3.3 of [ITU-T G.9960].

8.1.2.3.3.1 Extended header frame-type specific fields (E_FTSF)

8.1.2.3.3.1.1 E_FTSF for a PHY frame

If the 'EHI' field in the PHY-frame header of an MSG frame is set to one, the MSG frame shall include an extended PHY-frame header. If the 'FDI' field in the PHY frame header of an MSG frame is set to one, the 'E_FTSF' field shall convey the secondary transmission information as described in clause 10.2.2.5.

Table 8-9 lists the E_FTSF for a PHY frame.

Table 8-9 – E_FTSF for an MSG PHY frame type

Field	Octet	Bits	Description	Reference
End_Time	0-1	[15:0]	The latest end time of the secondary transmission	Clause 8.1.2.3.3.1.1.1
EmptyCRQFlag	2	[0]	Whether the CRQ is empty or not "0" indicates an empty CRQ "1" indicates a non-empty CRQ	Clause 8.1.2.3.3.1.1.2
NumberContentionSlots		[1]	The number of contention slots in the access channel. "0" indicates no access channel "1" indicates a access channel with three contention slots	Clause 8.1.2.3.3.1.1.3
Reserved		[7:2]	Reserved	Reserved by ITU-T (Note 2)
HeadDTQ		[7:0]	The DEVICE_ID of the secondary transmitter in the head of the DTQ	Clause 8.1.2.3.3.1.1.4
NewSecTx[1]	3	[7:0]	The DEVICE_ID of the secondary transmitter that has sent an AR that has been received successfully by the central node in contention slot 1 of the previous access channel. (Note 1)	Clause 8.1.2.3.3.1.1.5
NewSecTx[2]	4	[7:0]	The DEVICE_ID of the secondary transmitter that has sent an AR that has been received successfully by the central node in contention slot 2 of the previous access channel. (Note 1)	Clause 8.1.2.3.3.1.1.5
NewSecTx[3]	5	[7:0]	The DEVICE_ID of the secondary transmitter that has sent an AR that has been received successfully by the central node in contention slot 3 of the previous access channel. (Note 1)	Clause 8.1.2.3.3.1.1.5

Table 8-9 – E_FTSF for an MSG PHY frame type

Field	Octet	Bits	Description	Reference
Reserved	4-18	[128:0]	Reserved	Reserved by ITU-T (Note 2)
NOTE 1 – This field shall be ignored if contention slot 1 of the previous access channel is not indicated as "successful" in the previous feedback notification.				
NOTE 2 – Bits that are reserved by ITU-T shall be set to zero by the transmitter and ignored by the receiver.				

8.1.2.3.3.1.1.1 Ending time of the STW (Ending_Time)

The Ending_Time field shall indicate the latest time no later than which the transmission of the MSG frame sent by the secondary transmitter to the central node shall end. The Ending_Time should not exceed the ending time of the MSG frame sent by the central node to the primary receiver on the primary channel. It represents the time shift counted from the beginning of the current STW in TIME_UNIT units where the size of a TIME_UNIT is equal to the base TICK size multiplied by a constant factor defined in the MAP header. The values of TICK are defined in Table 10-1.

8.1.2.3.3.1.1.2 Empty CRQ flag (EmptyCRQFlag)

The EmptyCRQFlag field shall indicate the candidate secondary transmitters that are allowed to send ARs to the central node by indicating whether the CRQ is empty or not. If the 'EmptyCRQFlag' field indicates the CRQ is empty, all candidate secondary transmitters identified by the FD contention group information extension are allowed to send ARs to the central node; otherwise, only the candidate secondary transmitters belonging to the head of the CRQ are allowed to send ARs to the central node.

8.1.2.3.3.1.1.3 Number of contention slots (NumberContentionSlots)

This field is used to indicate the configuration of the secondary channel which could include an access channel or not. If there is an access channel on the secondary channel, then there are three contention slots in the STW; otherwise, if there is no access channel on the secondary channel, there is no contention slots in the STW.

The number of contention slots which could be three or zero. If the central node determines that there is not enough time to transmit all of the accumulated MSG frames of the secondary transmitters in the DTQ by the end of the FDSTXOP, then the central node shall indicate there is no contention slot in the STW by setting the 'NumberContentionSlots' field to zero; otherwise, there are three contention slots in the STW.

8.1.2.3.3.1.1.4 Head of the DTQ (HeadDTQ)

The HeadDTQ field shall indicate the DEVICE_ID of the secondary transmitter that is scheduled to send an MSG frame to the central node on the transmission channel in the STW. According to the rule of first come first served, the oldest secondary transmitter that is pending to send the MSG frame on the transmission channel should be the head of the DTQ.

8.1.2.3.3.1.1.5 New secondary transmitter (NewSecTx[i])

The NewSecTx[i] (i=1, 2, 3) field shall indicate the DEVICE_ID of the secondary transmitter which has sent an AR that has been received successfully by the central node in contention slot i of the previous access channel. This field shall be set to 0xFF and be ignored if contention slot i of the previous access channel is not indicated as "successful" in the previous feedback notification.

8.1.2.3.3.1.2 E_FTSF for a CTMG PHY frame

See clause 7.1.2.3.3.1.1 of [ITU-T G.9960].

8.1.2.3.3.1.3 E_FTSF for a BMSG PHY frame

See clause 7.1.2.3.3.1.2 of [ITU-T G.9960].

8.1.2.3.3.1.4 E_FTSF for a BACK PHY frame

See clause 7.1.2.3.3.1.3 of [ITU-T G.9960].

8.1.2.3.3.1.5 E_FTSF for ACK PHY frame

If the 'FDI' field in the ACK PHY-frame type specific field is set to '01', the E_FTSF for ACK PHY frame shall convey the 'DTQLength' information and the 'status' information for the full duplex transmission in the FDSTXOP. If the 'FDI' field in the ACK PHY-frame type specific field is set to '10', the E_FTSF for ACK PHY frame shall convey the 'DTQLength' information and the 'status' information for the transmission in CBTXOP as described in clause 10.2.2.3.8.

Table 8-10 lists the E_FTSF for the ACK PHY frame.

Table 8-10 – E_FTSF for ACK PHY frame type

Field	Octet	Bits	Description	Reference
ACKI_EXT	0 to 17	[143:0]	ACKI field extension	Clause 8.1.2.3.3.1.5.1
DTQLength	18	[2:0]	The length of the DTQ	Clause 8.1.2.3.3.1.5.2
Status		[7:3]	The status of the contention slots in the STW	Clause 8.1.2.3.3.1.5.3

8.1.2.3.3.1.5.1 ACKI field extension (ACKI_EXT)

See clause 7.1.2.3.3.1.4.1 of [ITU-T G.9960].

8.1.2.3.3.1.5.2 DTQ length (DTQLength)

The 'DTQLength' field shall indicate the number of secondary transmitters that have sent the ARs to the central node successfully and line up the DTQ to send the MSG frames to the central node. It shall be represented as a 4-bit unsigned integer with valid values in the range from 0 to 15.

When calculating the length of the DTQ, the newly arrived secondary transmitters which have successfully sent the ARs in the access channel have been taken into account.

8.1.2.3.3.1.5.3 Status

This field shall indicate the status of the contention slots in the access channel. This field shall be coded as shown in Table 8-11, with 'S' representing 'successful', 'C' representing 'collision' and 'I' representing 'idle'.

Table 8-11 – Format of the Status field

Status value (b ₇ b ₆ b ₅ b ₄ b ₃)	Status of contention slot 1	Status of contention slot 2	Status of contention slot 3
00000	S	S	S
00001	S	S	C
00010	S	S	I
00011	S	C	S
00100	S	C	C

Table 8-11 – Format of the Status field

Status value (b₇b₆b₅b₄b₃)	Status of contention slot 1	Status of contention slot 2	Status of contention slot 3
00101	S	C	I
00110	S	I	S
00111	S	I	C
01000	S	I	I
01001	C	S	S
01010	C	S	C
01011	C	S	I
01100	C	C	S
01101	C	C	C
01110	C	C	I
01111	C	I	S
10000	C	I	C
10001	C	I	I
10010	I	S	S
10011	I	S	C
10100	I	S	I
10101	I	C	S
10110	I	C	C
10111	I	C	I
11000	I	I	S
11001	I	I	C
11010	I	I	I
11011~11111	Reserved	Reserved	Reserved

8.1.3 Physical medium attachment (PMA) sublayer

See clause 7.1.3 of [ITU-T G.9960].

8.1.4 Physical medium dependent (PMD) sublayer

The functional model of the PMD is presented in Figure 8-1. In the transmit direction, the tone mapper divides the incoming symbol frames of the header and payload into groups of bits and associates each group of bits with a specific subcarrier onto which this group shall be loaded, as specified in clause 8.1.4.2. The constellation encoder converts each incoming group of bits into a complex number that represents the constellation point for this subcarrier. The constellation mapping process is described in clause 8.1.4.3. The unloaded supported subcarriers are modulated by a pseudo-random bit sequence generated as described in clause 8.1.4.2.

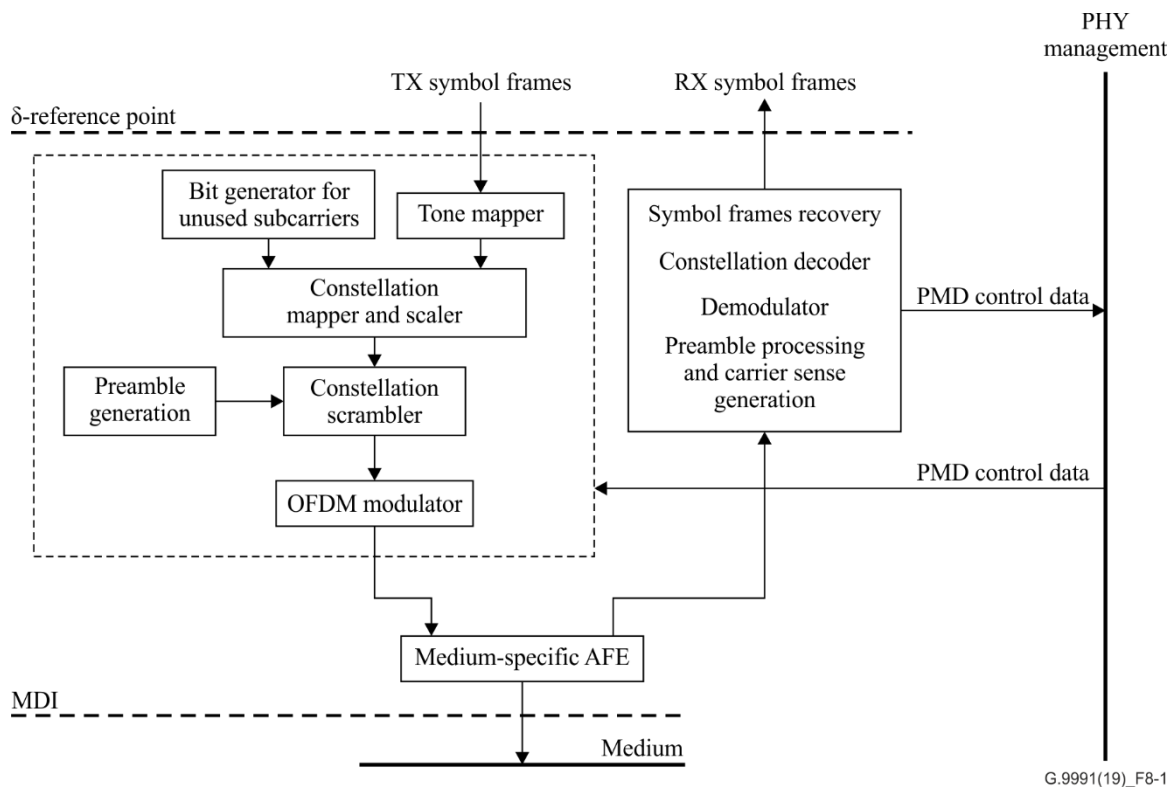

Figure 8-1 – Functional model of the PMD

The OFDM modulator (clause 8.1.4.4) converts the stream of the N complex numbers at its input into the stream of N complex valued time-domain samples. After adding the preamble, the transmit signal is up-shifted by F_{US} . The real part of the resultant signal is transmitted on to the medium. Parameters of the preamble (clause 8.1.4.5) are determined by the PHY management and depend on the type of the transmitted PHY frame.

Frames are output on to the medium with inter-frame gaps.

In the receive direction, the frames incoming from the medium are demodulated and decoded. The recovered symbol frames are transferred to the PMA via the δ -reference point. The preamble is processed and preamble data are passed to the PHY management entity.

An amplitude constant (DC offset) signal is added to the modulated signal in order to work within the LED operating range. This DC offset is removed in the receive path. The generation and characteristics of the DC offset will depend on the optical components and is therefore vendor discretionary. An example implementation of the addition of the DC offset to the modulated signal is shown in Annex A.

8.1.4.1 Subcarrier spacing and indexing

See clause 7.1.4.1 of [ITU-T G.9960].

8.1.4.2 Tone mapper

See clause 7.1.4.2 of [ITU-T G.9960].

8.1.4.3 Constellation encoder

See clause 7.1.4.3 of [ITU-T G.9960].

8.1.4.4 OFDM modulator

The OFDM modulator consists of the following major parts: IDFT, cyclic extension, windowing, overlap and add and frequency up-shift. The incoming signal to the modulator at the l th OFDM

symbol in the present frame for a single subcarrier, with index i , is the complex value $Z_{i,l}$ generated by the constellation encoder as described in clause 8.1.4.3 (for symbols of the header and the payload) or by preamble generator as described in clause 7.1.4.5.3 of [ITU-T G.9960] (for symbols of the preamble). Time-domain samples generated by the IDFT, after adding the cyclic prefix and windowing, are frequency up-shifted by F_{US} . The functional diagram of the OFDM modulator is presented in Figure 8-2.

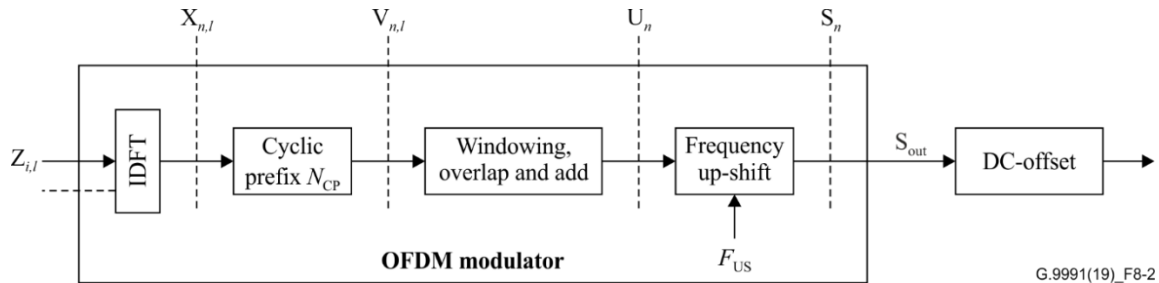

Figure 8-2 – Functional model of the ITU-T G.9960-based OFDM modulator

An amplitude constant (DC offset) signal is added to the modulated signal in order to work within the LED operating range.

The presented functional diagram and other figures presented in this clause do not imply any specific implementation. All aspects of signal processing used in the modulator shall comply with the equations and textual descriptions.

8.1.4.4.1 IDFT

See clause 7.1.4.4.1 of [ITU-T G.9960].

8.1.4.4.2 Cyclic extension

See clause 7.1.4.4.2 of [ITU-T G.9960].

8.1.4.4.3 Symbol timing

See clause 7.1.4.4.3 of [ITU-T G.9960].

8.1.4.4.4 Windowing, overlap and add

See clause 7.1.4.4.4 of [ITU-T G.9960].

8.1.4.4.5 Frequency up-shift

The frequency up-shift offsets the spectrum of the transmit signal shifting it by F_{US} . The value of F_{US} shall be a multiple of the subcarrier frequency F_{SC} :

$$F_{US} = m \cdot F_{SC}, \text{ where } m \text{ is an integer and } N/2 \leq m.$$

The valid values of m are dependent on the source of light used and can be calculated from the values given in clause 8.2.

The real and imaginary components of the signal after frequency up-shift (reference point s_n in Figure 8-2) shall be as follows:

$$s_n = u_{n/p} \times \exp\left(j \frac{2\pi mn}{Np}\right) = \text{Re}(s_n) + j \text{Im}(s_n) \quad \text{for } n = 0 \text{ to } [M(M_F - 1) + N_W(M_F - 1)] \times p - 1;$$

$$\text{Re}(s_n) = \text{Re}(u_{n/p}) \cos\left(\frac{2\pi mn}{Np}\right) - \text{Im}(u_{n/p}) \sin\left(\frac{2\pi mn}{Np}\right)$$

$$\text{Im}(s_n) = \text{Re}(u_{n/p}) \sin\left(\frac{2\pi mn}{Np}\right) + \text{Im}(u_{n/p}) \cos\left(\frac{2\pi mn}{Np}\right)$$

where $u_{n/p}$ is u_n after interpolation with factor p . The interpolation factor p is vendor discretionary and shall be equal to or higher than 2.

NOTE 1 – The minimum value of p sufficient to avoid distortions depends on the ratio between the up-shift frequency F_{US} and the bandwidth of the transmit signal $BW = N * F_{SC}$. It is assumed that an appropriate low-pass filter is included to reduce imaging.

NOTE 2 – The phase of the up-shift should be initialized to zero at the first sample of the preamble and be advanced by $\frac{2\pi m}{Np}$ per each sample (after interpolation).

8.1.4.4.6 Output signal

The output signal of the modulator shall be the real component of s_n :

$$S_{out} = \text{Re}(s_n).$$

8.1.4.4.7 Improved supported dimming range

If a wider range for dimming is supported, the following shall be performed together:

- In the runtime BAT, the odd-index subcarriers shall be used for bit-loading and the number of loaded bits on every even-indexed subcarrier shall be set to zero.
- The values of the input to the IDFT (i.e., $Z_{i,l}$) for all even-indexed subcarriers shall be set to zero.

8.1.4.5 Preamble, INUSE, PR, NACK and IDPS signals

See clause 7.1.4.5 of [ITU-T G.9960].

8.1.4.6 PMD control parameters

See clause 7.1.4.6 of [ITU-T G.9960].

8.1.4.7 Symbol boost

This Recommendation supports symbol boost as specified in clause 7.1.4.7 of [ITU-T G.9960].

8.1.5 Transmit PSD mask

See clause 7.1.5 of [ITU-T G.9960].

8.1.6 Electrical specifications

See clause 7.1.6 of [ITU-T G.9960].

8.2 Medium dependent specification

8.2.1 Physical layer specification

8.2.1.1 Control parameters

Table 8-12 shows the valid OFDM control parameters for various bandplans defined in VLC.

Table 8-12 – OFDM control parameters for VLC

Domain type	VLC (Note 2)		
	50 MHz (Note 3)	100 MHz (Note 4)	200 MHz (Note 5)
<i>N</i>	256	512	1024
<i>F_{SC}</i>	195.3125 kHz	195.3125 kHz	195.3125 kHz
<i>N_{GI}</i>	<i>N</i> /32 × <i>k</i> for <i>k</i> = 1, ..., 8 samples @ 50 Msamples/s	<i>N</i> /32 × <i>k</i> for <i>k</i> = 1, ..., 8 samples @ 100 Msamples/s	<i>N</i> /32 × <i>k</i> for <i>k</i> = 1, ..., 8 samples @ 200 Msamples/s
<i>N_{GI-HD}</i>	<i>N</i> /4 = 64 samples @ 50 Msamples/s	<i>N</i> /4 = 128 samples @ 100 Msamples/s	<i>N</i> /4 = 256 samples @ 200 Msamples/s
<i>N_{GI-DF}</i>	<i>N</i> /4 = 64 samples @ 50 Msamples/s	<i>N</i> /4 = 128 samples @ 100 Msamples/s	<i>N</i> /4 = 256 samples @ 200 Msamples/s
<i>β</i>	<i>N</i> /32 = 8 samples @ 50 Msamples/s	<i>N</i> /32 = 16 samples @ 100 Msamples/s	<i>N</i> /32 = 32 samples @ 200 Msamples/s
<i>F_{US}</i>	25 MHz	50 MHz	100 MHz
<i>F_{UC}</i>	0	0	0
Subcarrier indexing rule (Note 1)	Rule #1	Rule #1	Rule #1

NOTE 1 – See clause 7.1.4.1 of [ITU-T G.9960] for more details on subcarrier indexing rules.
NOTE 2 – The 50 MHz, 100 MHz and 200 MHz bandplans may be used by nodes operating in the same domain.
NOTE 3 – The range of subcarrier frequencies is between 0 and 50 MHz.
NOTE 4 – The range of subcarrier frequencies is between 0 and 100 MHz.
NOTE 5 – The range of subcarrier frequencies is between 0 and 200 MHz.

8.2.1.2 Preamble, PR signal and INUSE signal

8.2.1.2.1 Preamble structure

Table 8-13 illustrates the preamble structure for VLC.

Table 8-13 – Preamble structure for transmission over VLC

	1st section	2nd section	3rd section
Number of symbols (<i>N_i</i>)	10	4	2.5
Subcarrier spacing (<i>k_i</i> × <i>F_{SC}</i>)	<i>k_i</i> = 4	<i>k_i</i> = 4	<i>k_i</i> = 1

8.2.1.2.2 INUSE, PR and NACK signal generation parameters for VLC

Table 8-14 illustrates the INUSE, PR and NACK signal generation parameters for VLC.

Table 8-14 – INUSE, PR and NACK signal generation parameters for VLC

Parameter	Value
Number of symbols (<i>N_{PRS}</i>)	9
Subcarrier spacing (<i>k_i</i> × <i>F_{SC}</i>)	4

8.2.1.2.3 Modulation of the preamble for VLC

When using a "default" seed, the constellation scrambler LFSR generator (see clause 7.1.4.3.3 of [ITU-T G.9960]) shall be initialized at the beginning of each one of the used preamble sections to a seed that is section dependent, as defined in Table 8-15.

When using a "domain-specific" seed, the constellation scrambler LFSR generator (see clause 7.1.4.3.3 of [ITU-T G.9960]) shall be initialized at the beginning of each one of the used preamble sections to a set of seeds defined by the DM in the DM_Defined_Seed field of the additional domain information subfield (see clause 8.8.5.15 of [ITU-T G.9961]).

Table 8-15 – Default constellation scrambler initialization seed values for the preamble, for VLC

Medium	1st section	3rd section
VLC	16E6 ₁₆	1105 ₁₆

Domain-specific constellation scrambler initialization seed values for the preamble for VLC are for further study.

8.2.1.2.4 Modulation of the INUSE, PR and NACK signals for VLC

The constellation scrambler LFSR generator (see clause 7.1.4.3.3 of [ITU-T G.9960]) shall be initialized at the beginning of the INUSE, PR and NACK signals to the same seed used for the 1st preamble section, as defined in Table 8-15.

8.2.1.3 PSD mask specifications

No PSD mask is defined by this Recommendation since the power required to drive the emitting device may differ between implementations.

8.2.1.4 Permanently masked subcarriers

~~For baseband transmissions, s~~Subcarriers 0-10 (inclusive) shall be permanently masked over VLC. They shall not be used for transmission (neither data nor any auxiliary information).

8.2.1.5 Coexistence on VLC

This clause is for further study.

8.2.2 Transmitter EVM requirements

No EVM requirements are specified for this Recommendation.

8.2.3 Termination impedance

No termination impedance requirements are specified for this Recommendation.

8.2.4 Total transmit power

No total transmit power is defined by this Recommendation since the power required to drive the emitting device may differ between implementations.

8.2.5 Receiver input impedance

No receiver input impedance is specified for this Recommendation.

8.2.6 Longitudinal conversion loss

No longitudinal conversion loss is specified for this Recommendation.

9 Physical layer specification II (ACO-OFDM)

9.1 Medium independent specification

9.1.1 Functional model of the PHY

The functional model of the PHY is presented in Figure 9-1. The PMI and MDI are, respectively, two demarcation reference points between the PHY and MAC and between the PHY and the transmission medium. Internal reference points δ and α show separation between the PMD and PMA, and between the PCS and PMA, respectively.

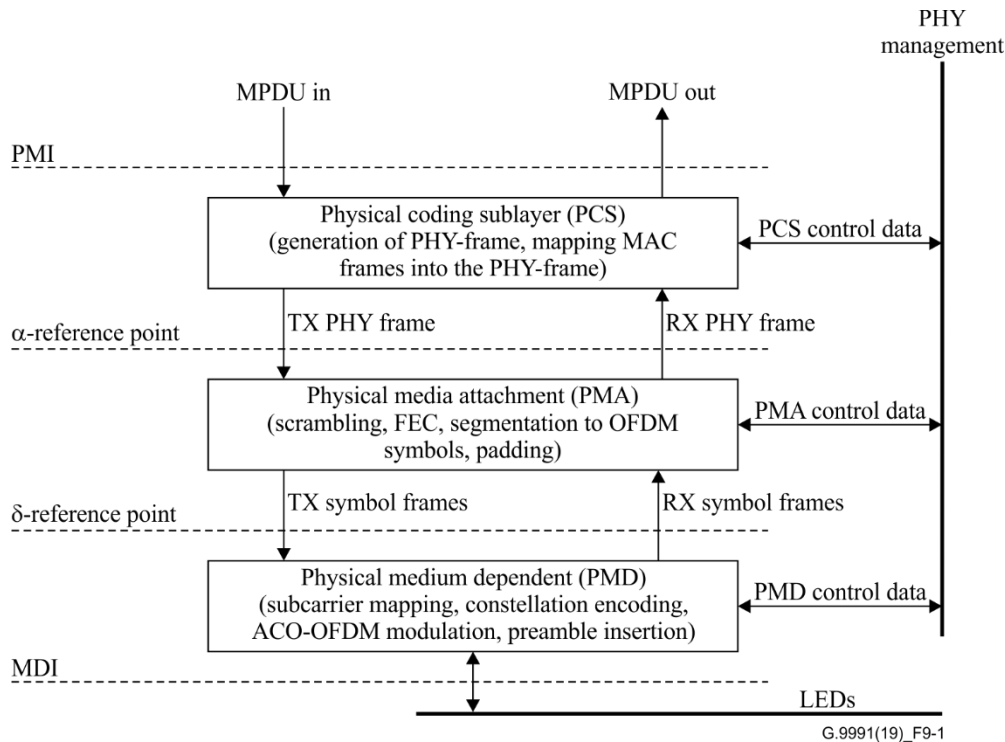

Figure 9-1 – Functional model of the PHY

In the transmit direction, data enters the PHY from the MAC via the PMI in blocks of bytes called MAC protocol data units (MPDUs). The incoming MPDU is mapped into a PHY frame in the PCS, scrambled and encoded in the PMA, modulated in the PMD and transmitted over the medium using ACO-OFDM modulation with the relevant parameters specified in clause 9.1.4. In the PMD, a preamble is added to assist synchronization and channel estimation in the receiver.

In the receive direction, frames entering from the medium via the MDI are demodulated and decoded. The recovered MPDUs are forwarded to the MAC via the PMI. The recovered PHY-frame headers are processed in the PHY to extract the relevant frame parameters specified in clause 9.1.2.3.

9.1.2 Physical coding sublayer (PCS)

The functional model of the PCS is presented in Figure 9-2. It is intended to describe in more detail the PCS functional block presented in Figure 9-1.

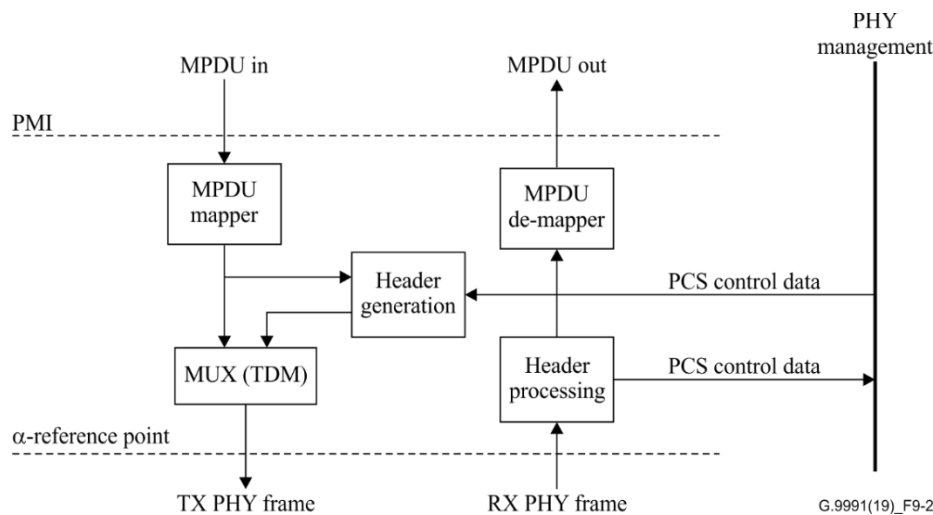

Figure 9-2 – Functional model of PCS

In the transmit direction, the incoming MPDU is mapped into a payload field of a PHY frame (clause 9.1.2.1) as described in clause 9.1.2.2. The PHY-frame header (clause 9.1.2.3) is then added to form a TX PHY frame. The TX PHY frame is passed across the α -reference point for further processing in the PMA.

In the receive direction, the decoded header and PHY-frame payload are processed and originally transmitted MPDUs are recovered from the payloads of received PHY frames and submitted to the PMI. Relevant control information conveyed in the PHY-frame header is processed and submitted to the PHY management entity.

9.1.2.1 PHY frame

See clause 8.1.2.1.

9.1.2.2 MPDU mapping

See clause 8.1.2.2.

9.1.2.3 PHY-frame header

See clause 8.1.2.3.

9.1.3 Physical medium attachment (PMA) sublayer

See clause 8.1.3.

9.1.4 Physical medium dependent (PMD) sublayer

The functional model of the PMD is presented in Figure 8-1. In the transmit direction, the tone mapper divides the incoming symbol frames including header and payload into groups of bits and associates each group of bits with a specific subcarrier onto which this group shall be loaded, as specified in clause 9.1.4.2. The constellation encoder converts each incoming group of bits into a complex number that represents the constellation point for this subcarrier. The constellation mapping process is described in clause 9.1.4.3. The unloaded supported subcarriers are modulated by a pseudorandom bit sequence generated as described in clause 9.1.4.2.

The asymmetrically clipped optical OFDM (ACO-OFDM) modulator (clause 9.1.4.4) converts the stream of the N complex numbers with Hermitian conjugate symmetry at its input into the stream of N real valued time-domain samples. After adding the preamble, the resultant signal is clipped at the zero level and only the positive part is used to transmit by the LED. Parameters of the preamble (clause 9.1.4.5) are determined by the PHY management and depend on the type of the transmitted PHY frame.

Frames are output on to the LED with inter-frame gaps.

In the receive direction, the frames incoming from the photodetector are demodulated and decoded. The recovered symbol frames are transferred to the PMA via the δ -reference point. The preamble is processed and preamble data are passed to the PHY management entity.

NOTE – An amplitude constant (DC offset) signal may be added to the modulated signal to ensure the system working within the LED operating range. This DC offset is removed in the receive path.

9.1.4.1 Subcarrier spacing and indexing

The subcarrier spacing F_{sc} is the frequency spacing between any two adjacent subcarriers. Valid values of subcarrier spacing are presented in clause 9.1.4.6 (PMD control parameters).

In an OFDM-based VLC system only the first half subcarriers are used for data transmission and the other half are used to impose Hermitian symmetry to ensure that the IDFT outputs are real valued time-domain samples (see clause 9.1.4.4).

The physical index i corresponds to the order of subcarriers in ascending frequency. The index i goes from 0 to $N - 1$.

Table 9-1 lists three modes of subcarrier usage. One of the them shall be used.

Table 9-1 – Three modes of subcarrier usage

Mode	Subcarrier usage
1	The i th subcarrier is active if i is odd and is inactive if i is even.
2	The i th subcarrier is active if $i \equiv 1, 2, \text{ or } 3 \pmod{4}$ and is inactive if $i \equiv 0 \pmod{4}$.
3	The i th subcarrier is active if $i \equiv 1, 2, 3, 4, 5, 6, \text{ or } 7 \pmod{8}$ and is inactive if $i \equiv 0 \pmod{8}$.

The logical index j indicates the order in which data is loaded on subcarriers.

The indexing rules that relate the physical index and the logical index are defined:

Mode 1: The index j goes from 0 to $N/4 - 1$ and

$$i = 2j + 1$$

Mode 2: The index j goes from 0 to $3N/8 - 1$ and

$$i = j + \left\lfloor \frac{j}{3} \right\rfloor + 1$$

Mode 3: The index j goes from 0 to $7N/16 - 1$ and

$$i = j + \left\lfloor \frac{j}{7} \right\rfloor + 1$$

Throughout this Recommendation, the term "subcarrier" refers to the valid subcarrier, unless otherwise noted. The term "subcarrier index" refers to the physical index, unless otherwise noted.

Not all odd subcarriers may always be used for data transmission; some of them have to be switched off in special circumstances. Others may be only used with reduced power. The latter functions are performed by subcarrier masking and gain scaling (see clauses 5.1 and 5.2 of [ITU-T G.9964]).

9.1.4.2 Tone mapper

The tone mapper divides the incoming symbol frames of the header and payload into groups of bits (according to the BATs and subcarrier grouping being used) and associates each group of bits with specific subcarriers onto which these groups shall be loaded. This information along with subcarrier-specific gain scaling values as described in clause 9.1.4.3 are passed to the constellation encoder.

9.1.4.2.1 Summary of subcarrier types

For the purpose of tone mapping, the following types of valid subcarriers are defined.

- 1) Masked subcarriers (MSCs) are those on which transmission is not allowed, i.e., the gain on this subcarrier shall be set to zero. Two types of MSC are defined:
 - Permanently masked subcarriers (PMSCs) – those that are never allowed for transmission. The list of PMSCs includes all even subcarriers and the PMSC mask, which is defined in clause 9.2. Data bits are never mapped on PMSCs.
 - Regionally masked subcarriers (RMSCs) – those that are not allowed for data transmission in some regions, while may be allowed in other regions. The list of RMSCs forms an RMSC mask, which consists of the subcarriers corresponding to subcarrier masks defined in the SM descriptor and masked amateur radio bands defined in the amateur radio band descriptor. The number of RMSCs, $\#RMSC = \#MSC - \#PMSC$. In this Recommendation, the set of RMSCs shall be empty.
- 2) Supported subcarriers (SSCs) are those on which transmission is allowed under restrictions of the relevant PSD mask. The number of SSCs, $\#SSC = N/2 - 1 - \#MSC$. The following types of SSC are defined:
 - Active subcarriers (ASCs) – those that have loaded bits ($b \geq 1$) for data transmission. ASCs are subject to constellation point mapping, constellation scaling and constellation scrambling as described in clause 9.1.4.3. Data bits shall be mapped on ASCs as described in clause 9.1.4.2.2.
 - Inactive subcarriers (ISCs) – those that do not have any data bits loaded (e.g., because signal to noise ratio (SNR) is low). The number of ISCs, $\#ISC = \#SSC - \#ASC$. ISCs can be used for measurement purposes or other auxiliary purposes. ISCs are subject to transmit power shaping. The signals transmitted on ISC are defined in clause 9.1.4.2.6.

9.1.4.2.2 Bit allocation tables (BATs)

See clause 7.1.4.2.2 of [ITU-T G.9960].

9.1.4.2.3 Transmitter-determined and receiver-determined mapping

See clause 7.1.4.2.3 of [ITU-T G.9960].

9.1.4.2.4 Special mappings

See clause 7.1.4.2.4 of [ITU-T G.9960].

9.1.4.2.5 BAT with subcarrier grouping

See clause 7.1.4.2.5 of [ITU-T G.9960].

9.1.4.2.6 Modulation of unloaded supported subcarriers

See clause 7.1.4.2.6 of [ITU-T G.9960].

9.1.4.2.7 Subcarrier index modulation

In subcarrier index modulation (SIM), the positions of used subcarriers in the frequency domain are utilized to transmit extra bits without additional power. Assuming the same bit loading over all subcarriers, given a dimming level, the average signal power per subcarrier can be determined. The maximum number of supported subcarriers (denoted by n_a) is determined using the signal power for a given bit error rate (BER) and a given constellation size.

$$n_a = \min\left\{\left\lfloor \frac{r^2 * n}{2N_0\gamma} \right\rfloor, n\right\}$$

where r denotes the RMS of total signal, N_0 denotes the noise power and the threshold γ is determined by a particular BER and other modulation parameters. If M -ary QAM modulation is adopted, the relationship between BER and SNR $\Gamma_{b(elec)}$ can be expressed as

$$BER = \frac{4(\sqrt{M}-1)}{\sqrt{M} \log_2(M)} Q\left(\sqrt{\frac{3 \log_2(M)}{M-1} \Gamma_{b(elec)}}\right) + \frac{4(\sqrt{M}-2)}{\sqrt{M} \log_2(M)} Q\left(3\sqrt{\frac{3 \log_2(M)}{M-1} \Gamma_{b(elec)}}\right)$$

Then the threshold γ is given by

$$\gamma = \Gamma_{b(elec)} * \log_2(M)$$

- If the total number of subcarriers (denoted by n) is no greater than the maximum number of supported subcarriers n_a , then the OFDM with all supported subcarriers shall be used.
- The equivalent number of subcarriers when SIM is used (denoted by n_e) is

$$n_e = n_l + \frac{b_l}{\log_2(M)}$$

where b_l denotes the extra transmission bits drawn from index modulation and the number of active subcarriers n_l can be expressed as

$$n_l = \min\left\{\left\lfloor \frac{r^2 * n}{2N_0\gamma_l} \right\rfloor, n\right\}$$

- If n_e is smaller than the maximum number of supported subcarriers n_a , then the OFDM with n_a supported subcarriers shall be used without SIM. The values of the input to the IDFT (i.e., $Z_{i,l}$) for the unused subcarriers shall be set to zero.
- If n_e is greater than n_a , then the OFDM with SIM shall be used. The values of the input to the IDFT (i.e., $Z_{i,l}$) for the unused subcarriers shall be set to zero.

The number of supported subcarriers shall be communicated from the transmitter to the receiver.

SIM with variable bit loading over all subcarriers is for further study.

9.1.4.3 Constellation encoder

See clause 8.1.4.3.

9.1.4.4 OFDM modulator

The OFDM modulator consists of the following major parts: IDFT, clipping, cyclic extension, windowing, overlap and add. The incoming signal to the modulator at the l th OFDM symbol in the present frame for a single subcarrier, with index i , is the complex value $Z_{i,l}$ generated by the constellation encoder as described in clause 9.1.4.3 (for symbols of the header and the payload) or by preamble generator as described in clause 7.1.4.5.3 of [ITU-T G.9960] (for symbols of the preamble). Hermitian symmetry shall be applied to $Z_{i,l}$ as follows to ensure the IDFT outputs are real valued time-domain samples:

$$Z_{0,l} = Z_{\frac{N}{2},l} = 0$$

$$Z_{i,l} = Z_{N-i,l}^* \quad \text{for } i = 1, 2, \dots, \frac{N}{2} - 1$$

where $*$ denotes complex conjugation. After time-domain samples generated by the IDFT, the real part of the resultant signal is clipped at the zero level. Then the cyclic prefix is added and windowing, overlap and add are processed. The functional diagram of the OFDM modulator is presented in Figure 9-3.

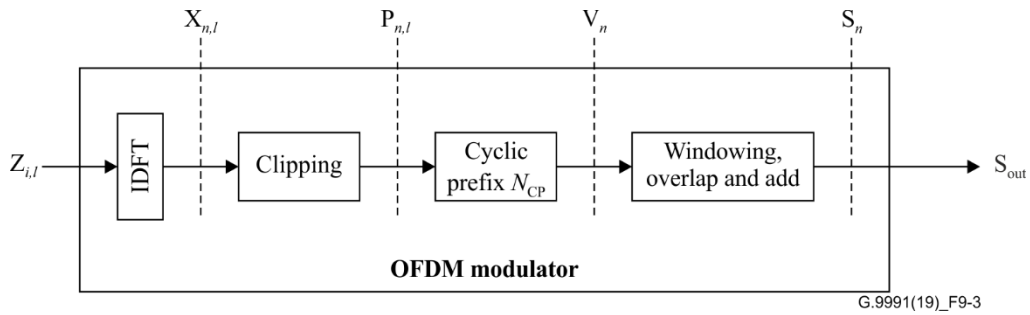

Figure 9-3 – Functional model of the ACO-OFDM modulator

The presented functional diagram and other figures presented in this clause do not imply any specific implementation. All aspects of signal processing used in the modulator shall comply with the equations and textual descriptions.

9.1.4.4.1 IDFT

See clause 8.1.4.4.1.

9.1.4.4.2 Clipping

Because of Hermitian symmetry, the result of IDFT $x_{n,l}$ is a real valued sequence theoretically. The transmitted signal should be clipped at the zero level and only the positive part of $x_{n,l}$ is used for transmission. The clipping can be expressed as in the follow equation:

$$P_{n,l} = (x_{n,l} + |x_{n,l}|)/2$$

Where $|\bullet|$ denotes the absolute value. To guarantee the real value, only the real parts of $x_{n,l}$ can be retained before clipping.

9.1.4.4.3 Cyclic extension

See clause 8.1.4.4.2.

9.1.4.4.4 Symbol timing

See clause 8.1.4.4.3.

9.1.4.4.5 Windowing, overlap and add

See clause 8.1.4.4.4.

9.1.4.4.6 Output signal

The output signal of the modulator shall be the real component of s_n :

$$S_{out-BB} = \text{Re}(s_n).$$

9.1.4.5 Preamble, INUSE, PR, NACK and IDPS signals

See clause 8.1.4.5.

9.1.4.6 PMD control parameters

See clause 8.1.4.6.

9.1.4.7 Symbol boost

See clause 8.1.4.7.

9.1.5 Transmit PSD mask

See clause 8.1.5.

9.1.6 Electrical specifications

See clause 8.1.6.

9.2 Medium dependent specification

See clause 8.2.

10 Data link layer specification

10.1 Functional model and frame formats

10.1.1 Functional model of the data link layer (DLL)

The functional model of the DLL is presented in Figure 10-1. The A-interface is the demarcation point between the application entity (AE) and the data link layer (DLL); the physical medium independent (PMI) interface is the demarcation point between the DLL and the physical (PHY) layer. Internal reference points x1 and x2 show logical separation between the application protocol convergence (APC) and LLC and between the LLC and MAC, respectively.

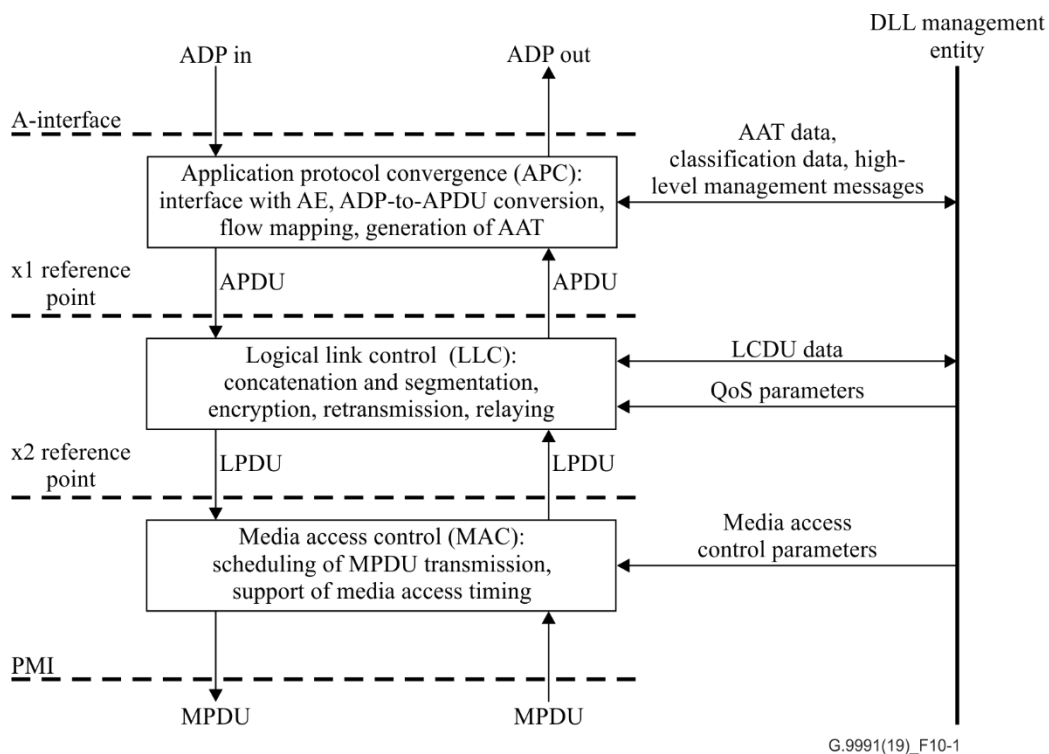

Figure 10-1 – Functional model of the DLL

In the transmit direction, application data primitive (ADP) sets enter the DLL from the AE across the A-interface. Every incoming ADP set meets the format defined by the particular application protocol; for an Ethernet type AE, the ADP set has one of the standard Ethernet formats, as presented in Annex A of [ITU-T G.9961] (Ethernet APC). Each incoming ADP set is converted by the APC into APC protocol data units (APDUs), which include all parts of the ADP set intended for communication to the destination node(s). The APC also identifies ADP classification primitives (e.g., priority tags), which can be used by the LLC to support QoS requirements assigned to the service delivered by the ADP. Furthermore, the APC is responsible for establishing flows of APDUs between peer APCs and assigning one or more queues for these flows according to the classification information associated with each APDU. The number of queues may depend on the profile of the device; for the Ethernet

APC, mapping of user priorities to the same destination into priority queues (traffic classes) shall follow Table III.1 of [ITU-T G.9960].

The APDUs are transferred to the LLC across the x1 reference point, which is both application independent and medium independent. In addition, LLC receives management data primitives from the DLL management entity intended for LLC control frames, which are mapped into link control data units (LCDUs). The LLC is responsible for establishing flows of LCDU (control frames) between peer LLCs.

In the LLC, the incoming APDU and LCDU are converted into LLC frames and may be encrypted using assigned encryption keys (see clause 11). LLC frames are subject to concatenation and segmentation, as described in clause 10.1.3.2. Segments are transformed into LLC protocol data units (LPDUs) by adding an LPDU header (LPH) and CRC. LPDUs are then passed to the MAC across the x2 reference point. The LLC is also responsible for retransmission and relay operations.

The MAC is responsible for concatenating LPDUs into MAC protocol data units (MPDUs) and then conveying these MPDUs to the PHY in the order determined by the LLC (scheduling, using number of transmission queues) and applying medium access rules established in the domain.

In the receive direction, MPDUs from the PHY enter the MAC across the PMI together with associated PHY frame error information. The MAC disassembles the received MPDU into LPDUs, which are passed over the x2 reference point to the LLC. The LLC recovers the original APDUs and LCDUs from the LPDUs, performs decryption if required and conveys them to the APC and LLC management entity, respectively. In the APC ADPs are generated from the received APDUs and conveyed to the AE.

The LLC is responsible for the decision regarding errored LPDUs. It decides whether to request retransmission of errored LPDUs (and generates the ACK response to assist retransmission), or to discard the errored LPDUs.

The functionality of the APC, LLC and MAC is the same for all types of medium, although some of their functions and control parameters may be adjusted for efficient operation of the transceiver over particular media. Specific control parameters for APC, LLC and MAC are described in clause 10.3.

NOTE – No assumptions should be made on the partitioning of APC, LLC and MAC in particular implementations; x1 and x2 are reference points and serve for the convenience of system definition.

10.1.2 Application protocol convergence (APC)

The functional model of the APC is presented in Figure 10-2. It is intended to describe in more detail the APC functional block presented in Figure 10-1.

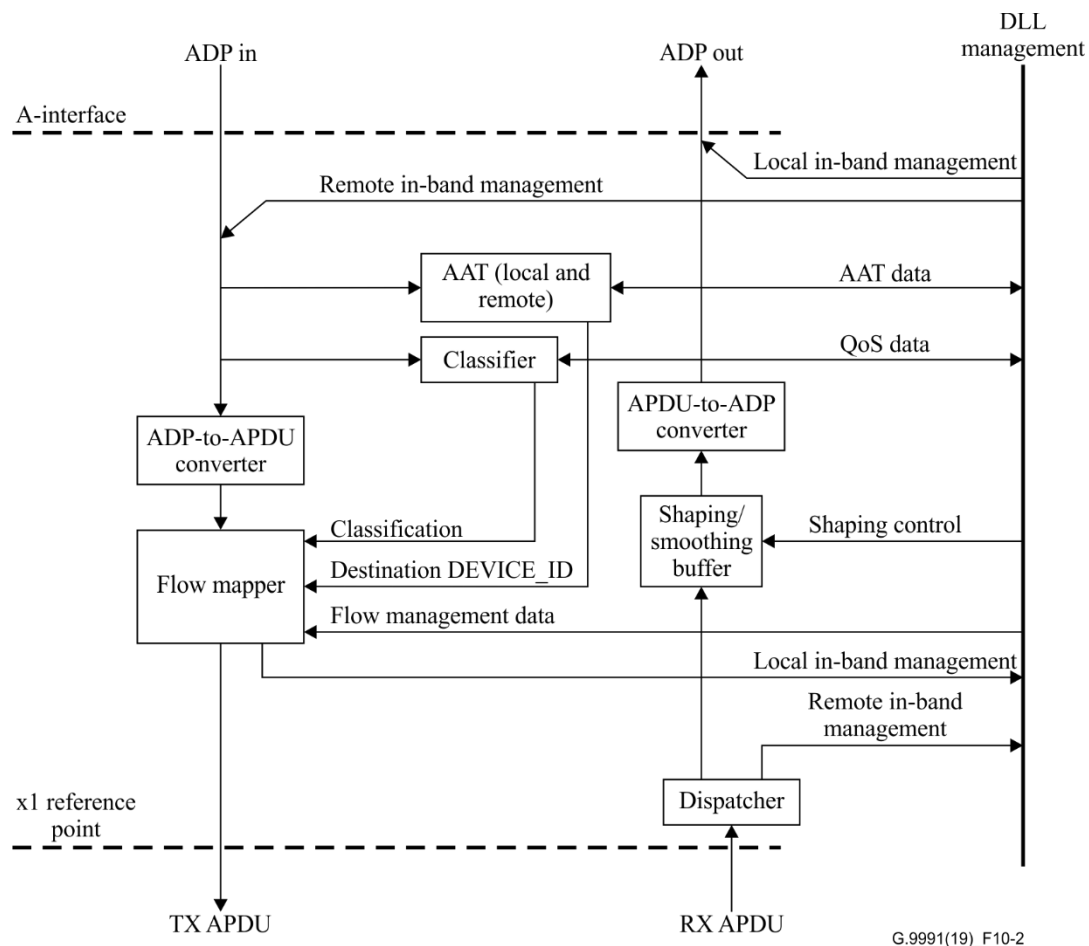

Figure 10-2 – Functional model of APC

In the transmit direction, the incoming ADP is converted into an APDU as defined in Annex A of [ITU-T G.9961]. The flow mapper maps APDUs into flows, depending on their destination DEVICE_ID, class of service and QoS support capabilities of the communicating nodes. Flows are established in the APC by DLL management after receiving relevant data units from the AE, or during admission to the network, or by high-level management requests coming across the A-interface, or upon request from another node (by means of flow establishment protocol messages coming across the x1 reference point). After mapping, each APDU, tagged with its FLOW_ID or PRI-Q, is sent across the x1 reference point to the LLC. The order of outgoing APDUs at the x1-reference point associated with a particular DID and a particular user priority and within a particular service flow shall be the same as the order of arrival of the ADPs sourcing these APDUs.

The data units of the in-band management messages arriving across the A-interface and addressed to the local node are directed to the DLL management entity ("Local in-band management", at the bottom of Figure 10-2). The in-band management messages generated by DLL management entity for the remote AE are converted to APDUs and sent across the x1 reference point ("Remote in-band management" at the top of Figure 10-2).

In the receive direction, the incoming APDUs crossing the x1 reference point are converted back into the ADP data unit primitives of the relevant application protocol. A shaping (smoothing) buffer, controlled by DLL management entity, may be included for traffic shaping of the outgoing (i.e., in the direction of the AE) ADP data units.

If addressed to the node, APDUs carrying in-band management messages from the remote AE are dispatched to the DLL management entity ("Remote in-band management" at the bottom of Figure 10-2). If addressed to the local AE, APDUs carrying in-band management messages from the

remote AE are converted to a standard ADP and passed to A-interface. The in-band management messages (e.g., responses) generated by DLL management entity for the local AE are sent to the AE across the A-interface as standard sets of data unit primitives ("Local in-band management" at the top of Figure 10-2).

The classification information embedded in the ADP is extracted from the incoming data units and may be used to set an appropriate type of traffic (flow) or to assign a user priority, or both, to convey the corresponding APDU through the network. Classification parameters are presented in Annex A of [ITU-T G.9961].

The local address association table (LAAT) contains in its first entry the MAC address of the node itself (i.e., REGID) and, in the rest of the table, the MAC addresses of the clients associated with the node. This data is collected from the incoming ADP data units; LAAT data is passed to the DLL management entity for network management purposes (see clause 10.4.3).

The remote address association table (RAAT) stores MAC addresses of other nodes in the domain and their associated clients that were advertised on the network.

The address association table (AAT) is formed by the aggregation of LAAT and RAAT.

10.1.3 Logical link control (LLC)

The functional model of the LLC is presented in Figure 10-3. It is intended to describe in more detail the LLC functional block presented in Figure 10-1.

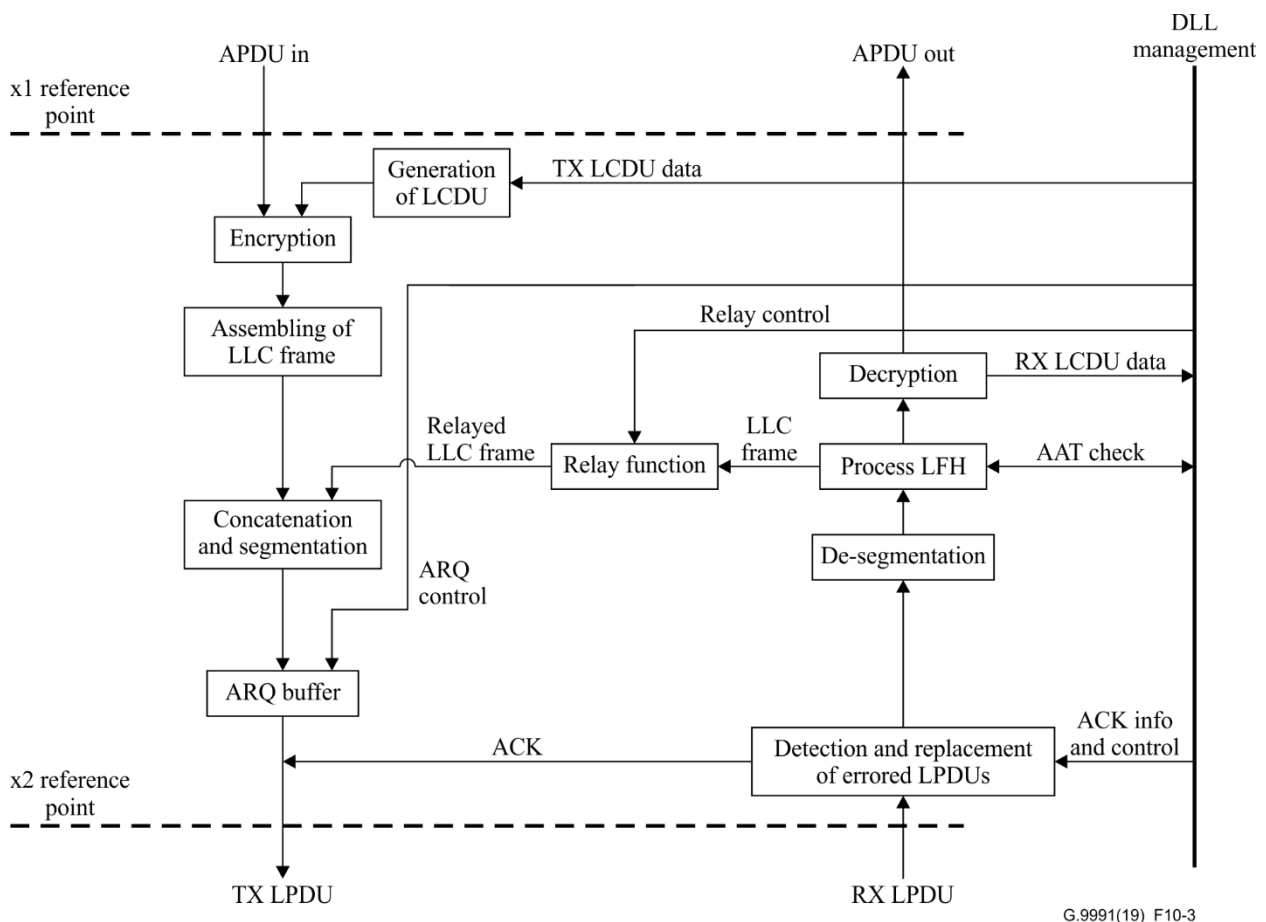

Figure 10-3 – Functional model of LLC

In the transmit direction, an LLC frame is formed from each incoming APDU crossing the x1 reference point, which may be encrypted using the encryption rules defined in clause 11. One or more LLC frames are concatenated and further divided into segments of equal size. Each segment is prepended by an LPDU header and appended with an LPDU CRC, forming an LPDU.

The LLC management data to be conveyed is assembled into an LCDU. The format of the LCDU is universal for all types of media and is described in clause 10.1.3.4. The LCDU is further mapped into an MPDU as described in clause 10.1.4.1.

LPDUs that are subject to automatic repeat request (ARQ) (need to be retransmitted) are extracted from the ARQ buffer and passed to the MAC to be assembled into the outgoing MPDU. To assist retransmission, the receive part of the LLC generates ACKs, which are also passed to the MAC (see clause 10.8). The number of LLC frames to be concatenated, the size of the segment and other MPDU formatting parameters are controlled by the LLC. The LPDUs are passed to the MAC across the x2 reference point.

In the receive direction, the incoming MPDU is disassembled into LPDUs in the MAC and passed over the x2 reference point. The LLC verifies the LPDUs, requests replacements for any errored ones if so instructed and recovers LLC frames from the LPDUs. The recovered LLC frames are decrypted and passed to APC as APDUs. Recovered LCDUs are passed to the DLL management entity.

The relay function extracts LLC frames that are subject to relaying and passes them to the transmit side, which concatenates them into the traffic to the next hop. The DLL management controls flow and priority settings for the relayed LLC frames. Relayed LLC frames shall not be decrypted.

10.1.3.1 LLC frame format

See clause 8.1.3.1 of [ITU-T G.9961].

10.1.3.2 Generation of LPDUs

See clause 8.1.3.2 of [ITU-T G.9961].

10.1.3.3 Generation of LPDUs for retransmission

See clause 8.1.3.3 of [ITU-T G.9961].

10.1.3.4 LCDU frame format

See clause 8.1.3.4 of [ITU-T G.9961].

10.1.4 Medium access control (MAC)

The functional model of the MAC is presented in Figure 10-4. It is intended to describe in more detail the MAC functional block presented in Figure 10-1.

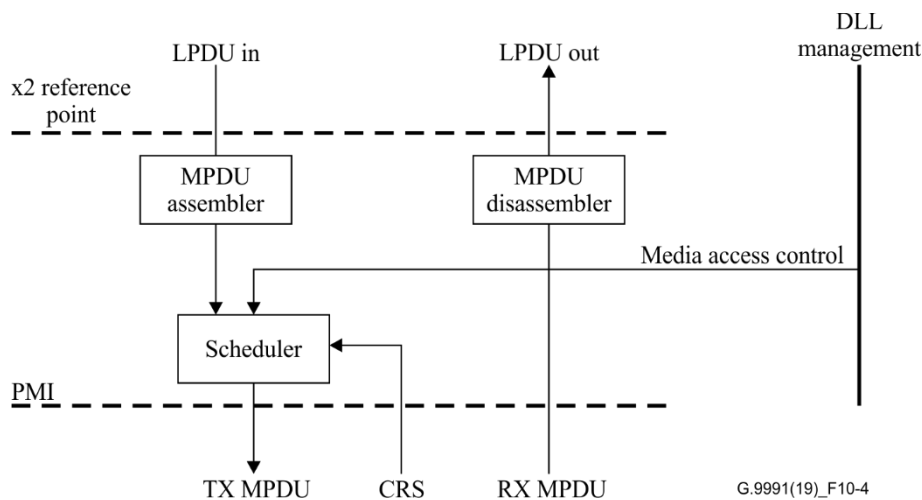

Figure 10-4 – Functional model of MAC

In the transmit direction, MPDUs are assembled from LPDUs passed over the x2 reference point. Then the MPDUs are scheduled for transmission using one of the medium access procedures described in clause 10.2. For scheduling, one or more transmission queues can be established. The carrier sense (CRS) primitive indicates whether the medium is busy or not. After being scheduled for transmission, the MPDU is passed to the PHY across the PMI. The octet 0 of the LPH of the LPDU#1 of the MPDU (see Figure 8-9 of [ITU-T G.9961]) shall be passed to the PHY first.

When the MPDU transmission requires usage of the RTS/CTS protocol, the DLL management shall instruct the MAC to schedule an RTS prior to passing the MPDU to the PHY. The scheduled MPDU will be passed to the PHY only if a correct CTS PHY frame was received (see clause 8.3.3.4.4 of [ITU-T G.9961]).

The MAC also schedules transmission of priority resolution (PR) and INUSE signals to support media access protocols described in clause 10.2 if these signals are required.

The MAC is also responsible for scheduling an ACK frame transmission by the PHY if ACK is required.

In the receive direction, the incoming MPDU is disassembled and the resulting LPDUs are passed to the LLC over the x2 reference point.

10.1.4.1 Assembling of an MPDU from LPDUs

See clause 8.1.4.1 of [ITU-T G.9961].

10.2 Medium access

10.2.1 MAP controlled medium access

See clause 8.2 of [ITU-T G.9961].

10.2.2 Transmission opportunities (TXOPs) and time slots (TSs)

The MAC cycle includes one or more transmission opportunities (TXOPs) of different types. The following types of TXOPs are defined:

- contention-free TXOP (CFTXOP)
- shared TXOP (STXOP)
- full duplex contention-free TXOP (FDCFTXOP)
- full duplex shared TXOP (FDSTXOP).

An STXOP is divided into one or more time slots (TSs) where each TS represents an opportunity to start transmitting for the node or nodes assigned to this TS. A node assigned to the TS may either use the opportunity to start transmitting during the TS, or pass on the opportunity to transmit.

Transmission rules within a TS depend on the type of the TS. If the node passes on the opportunity, it shall wait until the next opportunity to transmit in a subsequent TS assigned for this node. The duration of a TS (TS_DURATION) is medium-dependent and is defined in clause 8.4.

An STXOP can contain the following types of TSs:

- contention-free TS (CFTS)
- contention-based TS (CBTS).

An STXOP can be composed of only CFTSs, only CBTSs, or both CFTSs and CBTSs. An STXOP that is composed of CBTSs only is denoted as CBTXOP.

An example of a MAC cycle composed of TXOPs of different types is illustrated in Figure 10-5.

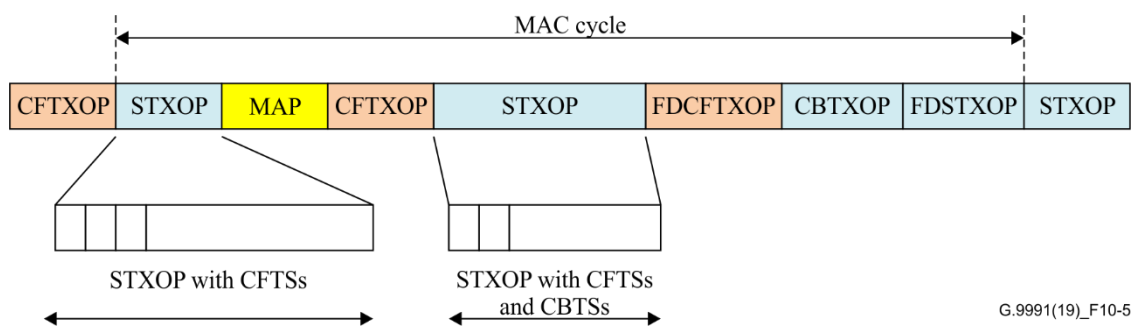

Figure 10-5 – Example of a MAC cycle structure

At least one MAP shall be sent each MAC cycle in a dedicated CFTXOP assigned by the domain master. This MAP shall be transmitted via a MAP-A frame (see clause 10.7.1).

The domain master shall plan medium access during a MAC cycle by dividing the available medium access time within the MAC cycle time into TXOPs. The domain master shall partition the MAC cycle into CFTXOPs, STXOPs, optional FDCFTXOP and optional FDSTXOP.

NOTE – The above partitioning should be done in accordance with service requirements of network nodes and domain scheduling decisions.

Medium access within STXOPs shall be performed using CFTSs and CBTSs. Each STXOP may contain zero, one or more CFTSs, each assigned to a given node. Similarly, each STXOP may contain zero, one, or more CBTSs, and each CBTS is assigned to several nodes potentially contending for this CBTS. Within an STXOP with no CFTS (i.e., a CBTXOP), medium access in the CBTS could be implemented as described in clause 10.2.2.3.4, or could be implemented as described in clause 10.2.2.3.8.

An FDCFTXOP shall be assigned to either a pair of nodes or three nodes. If an FDCFTXOP is assigned to a pair of nodes, simultaneous transmission and reception between these two nodes is allowed; if an FDCFTXOP is assigned to three nodes, one of these nodes is appointed as the central node, which is allowed to transmit to another node and receive from the third node simultaneously. All transmissions in the FDCFTXOP shall be contention-free.

An FDSTXOP shall be assigned to a group of nodes, one of which is appointed as the central node, which is fixed and allowed to transmit to another node and receive from the third node simultaneously. In the transmit direction, the central node shall transmit in a contention-free manner, while in the receive direction, other nodes shall share the TXOP to transmit to the central node.

The type, placement and duration of TXOPs within a MAC cycle and the order of the TSs inside a STXOP is assigned by the domain master according to internal scheduling decisions, which are beyond the scope of this Recommendation.

The format for describing the TXOPs and TS assignments in the MAP is described in clause 10.7.

10.2.2.1 Assignment of nodes and connections to TXOPs and TSs

See clause 8.3.1 of [ITU-T G.9961].

10.2.2.2 TXOP and TS attributes

See clause 8.3.2 of [ITU-T G.9961].

10.2.2.3 Medium access in STXOPs

An STXOP may contain zero, one or more than one TSs of CFTS or CBTS type.

Each TS inside an STXOP is identified by its order within the STXOP. Each CFTS may be assigned to:

- a single source node and a minimum user priority identified by the tuple (SID, PRI); or
- a data connection that a single source node originates, identified by the tuple (SID, FLOW_ID); or
- a single source node, a single destination node and a minimum user priority identified by the tuple (SID, DID, PRI).

A CBTS is assigned to a group of nodes as described in clause 10.7.4.1.5 and a minimum user priority as described in clause 10.7.4.2. The order in which TSs appear, and how nodes, connections or user priorities are assigned to them, is based on a scheduling policy used by the domain master. Those scheduling policies are beyond the scope of this Recommendation.

An STXOP is divided into a grid of TSs providing transmission opportunities to the nodes sharing the STXOP. The grid starts at the beginning of an STXOP and the grid timing is reset after each transmission as described in clause 10.2.2.3.1 below.

Nodes that share an STXOP shall track the passage of TSs on the line using carrier sensing and transmit only within their assigned TS.

In an STXOP with no CFTS (i.e., CBTXOP), if the 'CBTXOP indicator' in the basic TXOP descriptor is set to one, nodes assigned to each CBTS in the STXOP shall be the same group of nodes which is identified as described in clause 10.7.4.1.6, and nodes shall track the passage of TSs on the line using a different way from that described from clauses 10.2.2.3.1 to 10.2.2.3.6.

10.2.2.3.1 TS size and timing

See clause 8.3.3.1 of [ITU-T G.9961].

10.2.2.3.2 TS assignment rules

See clause 8.3.3.2 of [ITU-T G.9961].

10.2.2.3.3 Transmission in CFTS

See clause 8.3.3.3 of [ITU-T G.9961].

10.2.2.3.4 Transmission in CBTS

See clause 8.3.3.4 of [ITU-T G.9961].

10.2.2.3.5 Enhanced frame detection (EFD) TXOP

See clause 8.3.3.5 of [ITU-T G.9961].

10.2.2.3.6 TS grid synchronization loss and recovery

See clause 8.3.3.6 of [ITU-T G.9961].

10.2.2.3.7 Silent TXOP or TS

See clause 8.3.3.7 of [ITU-T G.9961].

10.2.2.3.8 Medium access in CBTXOP using DQ-based mechanism

If the STXOP contains CBTS only and the 'CBTXOP indicator' in the basic TXOP descriptor is set to one, nodes assigned to each CBTS in the CBTXOP shall be the same group of nodes and shall contend for the medium as described in this clause.

A contending node shall first send an access request (AR) to the DM. The transmission of the contending node shall be allowed only after the AR is successfully received by the DM.

Collisions may occur when a node is transmitting the AR to the DM. If collision occurs, the node shall enter the collision resolution queue (CRQ) and wait for its turn to retransmit the AR. Each node and the DM shall maintain a collision resolution queue (CRQ) to manage and resolve the collisions.

After the AR is successfully received by the DM, the node shall enter the data transmission queue (DTQ) and wait its turn to send the MSG frame to the DM in a contention-free manner. Each node and the DM shall maintain a data transmission queue (DTQ) to manage the transmission of MSG frames.

The detail of maintaining the CRQ and the DTQ shall be described in clause 10.2.2.3.8.2.

The acknowledgement to the reception of the ARs and the MSG frame shall be broadcasted to the contending nodes by the DM in an ACK frame and an IND frame. The nodes assigned to the CBTXOP shall manage and update their CRQs and DTQs based on the ACK frame and the IND frame.

10.2.2.3.8.1 Transmissions in CBTXOP

Transmission within the CBTXOP is illustrated as shown in Figure 10-6. The CBTXOP shall be divided into multiple TSs and each TS further includes one access channel, one (or zero) transmission channel and the transmission of one ACK frame and one IND frame. The access channel shall further contain three contention slots among which each node shall randomly choose one contention slot and send the access request (AR) to the DM on the chosen contention slot. The length of the contention slot shall be T_{cshd} (see clause 10.3).

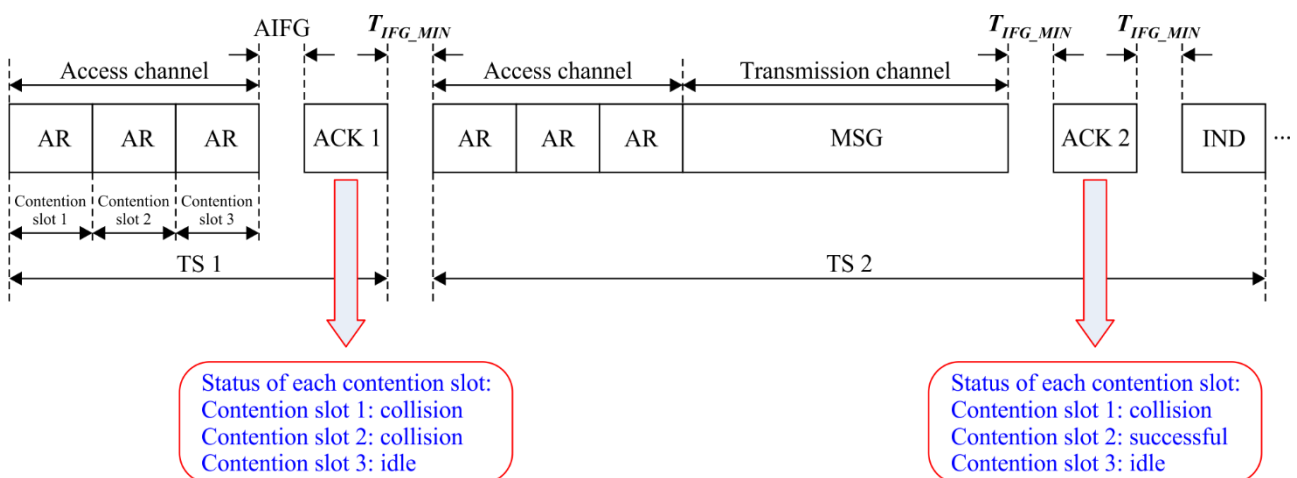

G.9991(19)_F10-6

Figure 10-6 – Half duplex transmission in the CBTXOP

The transmission channel shall start following the end of the access channel if the access channel exists and shall contain one transmission slot where the node shall send one MSG frame to the DM in a contention free manner. The length of the transmission channel shall be accommodated to the duration of the MSG frame sent by the node and it may vary in each TS.

The transmission channel shall exist only when the DTQ is not empty. The first TS in the CBTXOP shall always contain no transmission channel. For other TSs in the CBTXOP, the DM shall indicate to the nodes whether there is a transmission channel or not in the next TS in the current ACK frame.

If the transmission channel exists in the TS (e.g., TS 2 in Figure 10-6), the transmission of the ACK frame shall begin one AIFG after the end of the transmission channel; otherwise, the transmission of the ACK frame shall begin one AIFG after the end of the access channel (e.g., TS 1 in Figure 10-6). The ACK frame shall be broadcasted by the DM to the nodes and shall indicate the acknowledgement to the ARs sent on the access channel, the acknowledgement to the MSG frame sent on the transmission channel (if there is a transmission channel in the TS) as well as the existence of the transmission channel in the next TS. If the status of at least one contention slot is indicated as "successful" by the DM in the ACK frame, then the DM shall begin the transmission of the IND frame one AIFG after the end of the transmission of the ACK frame. The IND frame shall indicate the DEVICE_ID(s) of the node(s) which has (have) send the AR(s) that has (have) been received successfully by the DM in the contention slot(s) of which the status is indicated as "successful". Nodes shall update the CRQ and the DTQ accordingly based on the ACK frame and the IND frame as described in clause 10.2.2.4.2.

Next TS shall always start one T_{IFG_MIN} after the end of the transmission of the IND frame (or the ACK frame). Nodes shall keep tracking the TSs by detecting the ACK frames and the IND frames. The DM shall make sure the last TS complete before the end of the CBTXOP.

The AR sent on the access channel shall be an RTS frame with the 'FDI' field in the frame header set to '10' as described in clause 8.1.2.3.2.4.4.

The 'FDI' field in the frame header of the ACK frame shall be set to '10' as described in clause 8.1.2.3.2.3.8. The 'ACKDATA' field in the ACK frame shall indicate the reception status of the MSG frame sent on the transmission channel if there is a transmission channel in the TS.

10.2.2.3.8.2 Operation of the CRQ and the DTQ

Transmissions in the CBTXOP shall be accompanied by the operation of the CRQ and DTQ.

Both of the CRQ and DTQ shall be maintained by each node and the DM with two integer numbers:

- the length of the queue, RQ counter for CRQ and TQ counter for DTQ respectively
- the position of each node in the queue, pRQ counter and pTQ counter respectively.

Nodes and the DM shall initialize the RQ counter, TQ counter, pRQ counter and pTQ counter to zero at the beginning of each CBTXOP.

A node shall enter the CRQ when collision occurs in the contention slot which is chosen by the node to send the AR. A node shall enter the DTQ when the node has sent the AR to the DM successfully. Nodes in the CRQ and nodes in the DTQ shall line up according to the rule of first come first served and update their RQ counters, TQ counters, pRQ counters and pTQ counters based on the ACK frame sent by the DM as follows.

When a TS begins, if the 'CRQLength' field in the previous ACK frame is set to zero, all nodes identified by the CBTS nodes information extension are allowed to send ARs to the DM. If the nodes that are allowed to send ARs to the DM have MSG frames needed to be sent to the DM, they shall each choose a contention slot randomly among the 3 contention slots and send their ARs to the DM in the chosen slots. Otherwise, if the 'CRQLength' field in the previous ACK frame is set to a non-zero value, only nodes belonging to the head of the CRQ are allowed to retransmit ARs to the DM and other nodes queued in the CRQ shall decrease their pRQ counters by one. Nodes that are allowed to

retransmit ARs to the DM shall each choose a contention slot randomly among the 3 contention slots and retransmit their ARs to the DM in the chosen slots.

When the access channel ends, if the 'TCI' field in the previous ACK frame is set to '1', the transmission channel shall begin right after the end of the access channel and the node identified by the 'HeadDTQ' field in the previous ACK frame shall send an MSG frame to the DM on the transmission channel. Other nodes in the DTQ shall decrease their pTQ counters by one.

After the transmission channel ends (or after the access channel ends if there is no transmission channel in the TS), the DM shall broadcast an ACK frame to the nodes with the 'FDI' field in the frame header set to '10'.

The ACK frame shall convey the acknowledgement to the ARs sent on the access channel as well as the acknowledgement to the MSG frame sent on the transmission channel. If there is no transmission channel in the TS, the acknowledgement data to the MSG frame shall not be included in the ACK frame.

Acknowledgement to the ARs shall be indicated by the status of each contention slots in the access channel which could be 'idle', 'successful' or 'collision'. If a valid preamble is detected by the DM in the contention slot but a valid PHY frame header is not detected by the DM, then the status of this contention slot shall be "collision". If a valid preamble is detected by the DM in the contention slot and a valid PHY frame header is also detected by the DM, then the status of this contention slot shall be "successful". If no valid preamble is detected by DM in the contention slot, then the status of this contention slot shall be "idle".

The ACK frame shall also include an acknowledgement to the MSG frame sent by the node on the transmission channel (if the transmission channel exists in the TS) and the format of the acknowledgement shall be described in clause 8.1.2.3.2.3.

The ACK frame shall also indicate the existence of the transmission channel in the next TS by setting the 'TCI' field. If the 'DTQLength' field indicates an empty DTQ, there shall be no transmission channel in the next TS and the 'TCI' field in the ACK frame shall be set to zero; otherwise, if the 'DTQLength' field indicates a non-empty DTQ, there shall be a transmission channel in the next TS and the 'TCI' field in the ACK frame shall be set to one.

If the status of at least one contention slot is indicated as "successful" by the DM in the ACK frame, the DM shall broadcast an IND frame to the nodes one AIFG after the end of the transmission of the ACK frame. The IND frame shall indicate the DEVICE_ID(s) of the specific node(s) which has (have) sent the AR(s) that has (have) been received successfully by the DM in the contention slot(s) of which the status is indicated as "successful". The node(s) which has (have) sent AR(s) in a contention slot of which the status is indicated as "successful" shall compare the DEVICE_ID(s) with its (their) own DEVICE_ID(s) so as to determine whether there is a detection error occurred at the DM.

Nodes shall update their RQ counters and TQ counters based on the ACK frame and the IND frame. Each node shall set its RQ counter to 'CRQLength' and set its TQ counter to 'DTQLength'. If the 'Status' field in the ACK frame indicates there are M ($0 \leq M \leq 3$) contention slots of which the status is 'successful', N ($0 \leq N \leq 3$) contention slots of which the status is 'collision' and K ($0 \leq K \leq 3$) contention slots of which the status is 'idle', then each node which has sent an AR in contention slot X (X = 1, 2, 3) of the access channel in the current TS shall update its pRQ counter and pTQ counter according to the following rules:

- If the chosen contention slot X by the node is the i^{th} ($1 \leq i \leq M$) contention slot among the M contention slots of which the status is 'successful', then the node shall wait to receive the following IND frame sent by the DM and determine whether the AR sent by itself is received successfully or not by comparing its own DEVICE_ID with the value of 'Node[X]' field in the IND frame. The node shall set its pTQ counter to $DTQLength - M + i$ if the two DEVICE_IDs are matched; otherwise, the node shall infer a detection error in the contention

slot X of the channel and shall set its pRQ value based on the number of collisions newly occurred (N) and the CRQ status in the current TS. If N is equal to 0 and the CRQ is not empty, the node shall line up at the last place of the CRQ. If N is equal to 0 and the CRQ is empty, the node shall resend the AR in the next TS without entering the CRQ. If N is equal to one, the node shall have the same position in the CRQ as those nodes which have sent ARs in the only contention slot indicated as "collision" in current TS. If N is equal to two, the node shall have the same position in the CRQ as those nodes which have sent ARs in the contention slot of which the status is indicated as "collision" in the current TS and that is closer to contention slot X in the time axis among the two contention slots indicated. If the two contention slots have the same distance towards contention slot X in the time axis, the earlier one shall be chosen by the node.

- If the chosen contention slot X by the node is the j^{th} ($1 \leq j \leq N$) contention slot among the N contention slots of which the status is 'collision', then the node shall set its pRQ counter to $\text{CRQLength} - N + j$.
- If the chosen contention slot X by the node is indicated as 'idle', the node shall infer a detection error at the DM. The node shall set its pRQ value based on the number of collisions newly occurred (N) and the CRQ status in the current TS. If N is equal to 0 and the CRQ is not empty, the node shall line up at the last place of the CRQ. If N is equal to 0 and the CRQ is empty, the node shall resend the AR in the next TS without entering the CRQ. If N is equal to one, the node shall have the same position in the CRQ as those nodes which have sent ARs in the only contention slot indicated as "collision" in the current TS. If N is equal to two, the node shall have the same position in the CRQ as those nodes which have sent ARs in the contention slots of which the status is indicated as "collision" and that is closer to contention slot X in the time axis among the two contention slots indicated. If the two contention slots have the same distance towards contention slot X in the time axis, the earlier one shall be chosen by the node.

The above steps shall repeat in each TS within the CBTXOP till the end of the CBTXOP.

10.2.2.4 Medium access in CFTXOPs

See clause 8.3.4 of [ITU-T G.9961].

10.2.2.5 Medium access in FDSTXOP

The FDSTXOP shall be scheduled for asymmetrical full duplex transmissions, of which the primary transmission is contention-free and the secondary transmission is contention-based.

The primary transmission within an FDSTXOP shall be assigned to the central node for contention free transmission to the primary receiver on the primary channel as described in clause 10.2.2.5.1. The secondary transmission shall be assigned to a group of candidate secondary transmitters identified by the FD contention group information extension in the FDSTXOP descriptor for contention-based transmission on the secondary channel.

When a candidate secondary transmitter needs to send MSG frames to the central node, it shall first send an access request (AR) to the central node in a contention-base manner. The candidate secondary transmitter shall become the secondary transmitter and be allowed to transmit the MSG frame to the central node only after the AR is received successfully by the central node. Collisions may occur when the candidate secondary transmitter is transmitting the AR to the central node. If collision occurs, the candidate secondary transmitter shall enter the collision resolution queue (CRQ) to wait for its turn to retransmit the AR. If the AR is received successfully by the central node, the candidate secondary transmitter shall become the secondary transmitter and enter the data transmission queue (DTQ) to wait its turn to send the MSG frame to the central node in a contention-free manner.

Each candidate secondary transmitter and the central node shall maintain a collision resolution queue (CRQ) to manage and resolve the collisions occurred. Each secondary transmitter and the central

node shall maintain a data transmission queue (DTQ) to manage the transmission of MSG frames. The detail of maintaining the CRQ and the DTQ shall be as described in clause 10.2.2.5.2.

The secondary channel in the FDSTXOP shall be divided into multiple secondary transmission windows (STWs) discontinuously. As shown in Figure 10-7, each STW corresponds to an MSG frame that is transmitted on the primary channel and the duration of each STW is constrained by the duration of the corresponding transmission of the MSG frame sent on the primary channel. The STW shall always start T_0 later than the starting time of the primary transmission and end no later than the ending time of the primary transmission. The ending time of the STW shall be indicated in the MSG frame header (see clause 8.1.2.3.3.1).

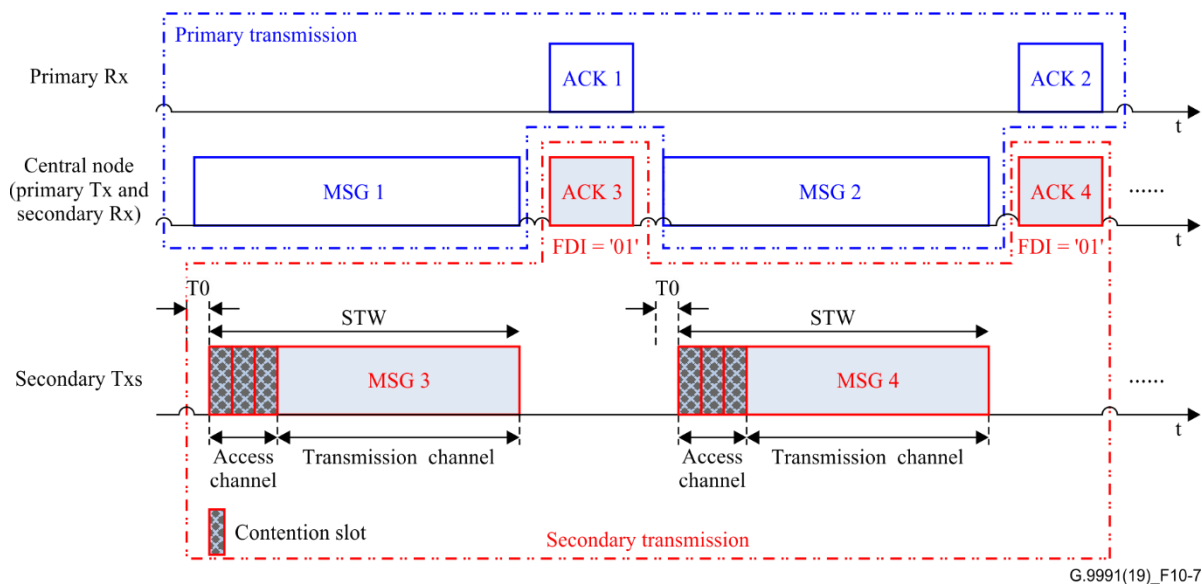

Figure 10-7 – An example of full duplex transmission in FDSTXOP

An STW may contain zero or one access channel and one transmission channel. The access channel shall further include three contention slots among which the candidate secondary transmitters shall choose one contention slot randomly and send their access requests (ARs) to the central node on the chosen contention slots. The length of the contention slot shall be T_{csfd} (see clause 10.3). The transmission channel shall contain one transmission slot where the secondary transmitter shall send an MSG frame to the central node in a contention free manner. If the STW contains an access channel, the transmission channel shall begin at the same time as the access channel ends; otherwise, the transmission channel shall begin at the same time as that of the STW. The duration of the transmission channel in each STW may vary with the durations of the primary transmissions.

The candidate secondary transmitters shall send the ARs to the central node on the access channel and the secondary transmitter shall send the MSG frame to the central node on the transmission channel within the STW while the primary transmission is ongoing.

One AIFG after the ending time of the primary transmission, the primary receiver shall send an ACK frame to the central node, while the central node shall send an ACK frame to the candidate secondary transmitters and the secondary transmitters at the same time, with the feedback notification encapsulated in the frame header of the ACK frame.

The above steps shall repeat in each STW within the FDSTXOP till the end of the FDSTXOP.

The central node may transmit multiple MSG frames to the primary receiver on the primary channel within the FDSTXOP, thus there might be multiple STWs within the FDSTXOP.

The central node shall make sure the last STW and the transmission of its corresponding ACK frame complete before the end of the FDSTXOP.

10.2.2.5.1 Primary transmission in FDSTXOP

The primary transmission shall be assigned to the central node for contention free transmission and the connections belonging to the primary transmission shall be identified by the following tuples:

- the DEVICE_ID of the central node and a minimum user priority (SID, PRI); or
- the DEVICE_ID of the central and the flow that the central node originates (SID, FLOW_ID); or
- the DEVICE_ID of the central node, a single destination node and a minimum user priority (SID, DID, PRI).

The domain master shall indicate the tuple in the FDSTXOP descriptor by setting the 'FD TXOP descriptor' to one and the 'SID' field to the DEVICE_ID of the central node.

The DM shall guarantee the connection assigned to the primary transmission of the FDSTXOP be a connection using the Imm-ACK protocol.

10.2.2.5.2 Secondary transmission in FDSTXOP

Secondary transmissions in the FDSTXOP shall be accompanied by the operation of the CRQ and DTQ.

The CRQ shall be maintained by each candidate second transmitter and by the central node. The DTQ shall be maintained by each secondary transmitter and by the central node. Both the CRQ and the DTQ shall be maintained with two integer numbers:

- the length of the queue, RQ counter for CRQ and TQ counter for DTQ respectively;
- the position of each node in the queue, pRQ counter and pTQ counter respectively. The pTQ counter maintained by the central node shall record each secondary transmitter's position in the DTQ counter. Note that the central node shall not maintain the pRQ counter.

The RQ counter, TQ counter, pRQ counter and pTQ counter shall be initialized to zero at the beginning of each FDSTXOP. Once the candidate secondary transmitters enter the CRQ or the secondary transmitters enter the DTQ, they shall line up according to the rule of first come first served. The secondary transmitters (including the candidate secondary transmitters) and the central node shall track and update the RQ counter, TQ counter, pRQ counter and pTQ counter as follows.

Candidate secondary transmitters and secondary transmitters shall keep tracking the STWs within the FDSTXOP by detecting the frame header of the MSG frame sent by the central node. When a valid frame header of the MSG frame sent by the central node is detected within the FDSTXOP, the candidate secondary transmitters and secondary transmitters shall parse the frame header to obtain the secondary transmission information encapsulated in the E_FTSF field of the MSG frame (see clause 8.1.2.3.3.1.1). The secondary transmission information includes: the DEVICE_ID of the candidate secondary transmitter that has sent an AR that has been received successfully by the central node, the configuration information of the STW which indicates the number of the contention slots (three or none) in the access channel, the ending time of the STW, the candidate secondary transmitters allowed to transmit ARs on the access channel and the DEVICE_ID of the secondary transmitter which is scheduled to transmit the MSG frame to the central node on the transmission channel.

The 'NewSecTx[i]' ($i \leq 3$) field (see clause 8.1.2.3.3.1.1.5) shall indicate the DEVICE_ID of the candidate secondary transmitter which has sent an AR that has been received successfully by the central node in contention slot i of the previous access channel. If the feedback notification that corresponds to the previous access channel indicates the status of contention slot i ($i \leq 3$) is successful, the candidate secondary transmitters which have sent ARs in contention slot i of the previous access channel shall compare their DEVICE_IDs with the value of 'NewSecTx[i]'. The candidate secondary transmitter shall become a secondary transmitter and enter the DTQ if its own

DEVICE_ID matches NewSecTx[i]; otherwise, the candidate secondary transmitter shall infer a detection error occurred at the central node.

If the 'NumberContentionSlots' field (see clause 8.1.2.3.3.1.1.3) in the MSG frame indicates 3 contention slots, then the STW shall begin with an access channel and the candidate secondary transmitters that are allowed to send ARs shall send ARs to the central node on the access channel. If the 'EmptyCRQFlag' field (see clause 8.1.2.3.3.1.1.2) indicates an empty CRQ, then all of the candidate secondary transmitters are allowed to send ARs to the central node in the access channel. Candidate secondary transmitters that are allowed to send ARs and have MSG frames needed to be sent to the central node shall each choose a contention slot randomly among the 3 contention slots and send their ARs to the central node in the chosen slot. If the 'EmptyCRQFlag' field (see clause 8.1.2.3.3.1.1.2) indicates a non-empty CRQ, then the candidate secondary transmitters belonging to the head of the CRQ are allowed to send ARs to the central node in the access channel and other candidate secondary transmitters queued in the CRQ shall decrease their pRQ counters by one. Candidate secondary transmitters that are allowed to send ARs shall each choose a contention slot randomly among the 3 contention slots and send their ARs to the central node in the chosen slots.

If the 'NumberContentionSlots' field (see clause 8.1.2.3.3.1.1.3) in the detected secondary transmission information indicates zero contention slot, there shall be no access channel in the STW and no ARs shall be send in the current STW.

The AR shall be an RTS frame with the 'FDI' field in the frame header set to '01' (see clause 8.1.2.3.2.4).

The central node shall determine the status of each contention slot in the STW. The status of each contention slot could be 'idle', 'successful' or 'collision'. If a valid preamble is detected by the central node in the contention slot but a valid PHY frame header is not detected by the central node, then the status of this contention slot shall be "collision". If a valid preamble is detected by the central node in the contention slot and a valid PHY frame header is also detected by the central node, then the status of this contention slot shall be "successful". If no valid preamble is detected by the central node in the contention slot, then the status of this contention slot shall be "idle".

When the secondary transmitters determine the transmission channel in the STW begins, the secondary transmitter indicated by the 'HeadDTQ' field shall send an MSG frame to the central node on the transmission channel. The secondary transmitter shall make sure that the transmission ends no later than the 'Ending_Time'. Other secondary transmitters queued in the DTQ shall decrease their pTQ counters by one.

One AIFG after the ending time of the primary transmission, when the primary receiver is sending the ACK frame to the central node on the primary channel, the central node shall send an ACK frame to the candidate secondary transmitters and the secondary transmitters on the secondary channel at the same time. The feedback notification shall be encapsulated in the frame header of the ACK frame sent by the central node, with the 'FDI' field in the frame header set to '01' and the 'DID' field in the frame header set to '252'.

The feedback notification shall indicate the status of each contention slot of the access channel in the STW and the acknowledgement to the MSG frame sent by the secondary transmitter on the transmission channel. Each candidate secondary transmitter shall set its RQ counter to CRQLength and each secondary transmitter shall set its TQ counter to DTQLength. If the 'Status' field in the feedback notification indicates that there are M ($0 \leq M \leq 3$) contention slots of which the status is 'successful', N ($0 \leq N \leq 3$) contention slots of which the status is 'collision' and K ($0 \leq K \leq 3$) contention slots of which the status is 'idle', then each candidate secondary transmitter which has sent an AR in contention slot X ($X = 1, 2, 3$) shall update its pRQ counter and pTQ counter according to the following rules:

- If the chosen slot by the candidate secondary transmitter is the i^{th} ($0 \leq i \leq M$) contention slot among the M contention slots of which the status is indicated as 'successful', the candidate secondary transmitter shall wait to receive the next MSG frame sent by the central node and determine whether the AR sent by itself is received successfully or not by comparing its own DEVICE_ID with the 'NewSecTx[X]' field encapsulated in the MSG frame. The candidate secondary transmitter shall become a secondary transmitter and shall set its pTQ to $DTQLength - M + i$ if its own DEVICE_ID matches NewSecTx[X]; otherwise, the candidate secondary transmitter shall infer a detection error in contention slot X of the previous access channel and shall set its pRQ value based on the number of collisions newly occurred (N) in the previous access channel and the CRQ status in the current access channel. If N is equal to 0 and the CRQ is not empty, the candidate secondary transmitter shall line up at the last place of the CRQ. If N is equal to 0 and the CRQ is empty, the candidate secondary transmitter shall resend the AR in the current access STW without entering the CRQ. If N is equal to one, the candidate secondary transmitter shall have the same position in the CRQ as those candidate secondary transmitters which have sent ARs in the only contention slot of which the status is indicated as "collision" in the previous access channel. If N is equal to two, the candidate secondary transmitter shall have the same position in the CRQ as those candidate secondary transmitters which have sent ARs in the contention slot of which the status is indicated as "collision" in the previous access channel and that is closer to contention slot X in the time axis among the two contention slots indicated. If the two collisions have the same distance towards contention slot X in the time axis, the earlier one shall be chosen by the candidate secondary transmitter.
- If the chosen slot by the candidate secondary transmitter is the j^{th} ($0 \leq j \leq N$) contention slot among the N contention slots of which the status is indicated as 'collision', then the candidate secondary transmitter shall set its pRQ to $CRQLength - N + j$. If the chosen slot by the candidate secondary transmitter is indicated as 'idle', the candidate secondary transmitter shall infer a detection error at the central node. The candidate secondary transmitter shall set its pRQ value based on the number of collisions newly occurred (N) and the CRQ status in the current access channel. If N is equal to 0 and the CRQ is not empty, the candidate secondary transmitter shall line up at the last place of the CRQ. If N is equal to 0 and the CRQ is empty, the candidate secondary transmitter shall resend the AR in the next access channel without entering the CRQ. If N is equal to one, the candidate secondary transmitter shall have the same position in the CRQ as those candidate secondary transmitters which have sent ARs in the only contention slot of which the status is indicated as "collision" in the current access channel. If N is equal to two, the candidate secondary transmitter shall have the same position in the CRQ as those candidate secondary transmitters which have sent ARs in the contention slot of which the status is indicated as "collision" and that is closer to contention slot X in the time axis among the two contention slots indicated. If the two collisions have the same distance towards contention slot X in the time axis, the earlier one shall be chosen by the candidate secondary transmitter.
- If the central node finds out that there is not enough time to transmit all of the accumulated MSG frames of the secondary transmitters in the DTQ by the end of the FDSTXOP, then the central node may not assign contention slots in the STW anymore and the number of the contention slots could be zero.

10.2.2.6 Medium access in FDCFTXOP

This clause is for further study.

10.2.2.7 Transmission using PHY frame bursting

See clause 8.3.5 of [ITU-T G.9961].

10.2.2.8 Scheduled inactivity

See clause 8.3.6 of [ITU-T G.9961].

10.2.2.9 Bidirectional transmissions

See clause 8.3.7 of [ITU-T G.9961].

10.2.2.10 Extended acknowledgements

See clause 8.3.8 of [ITU-T G.9961].

10.3 Control parameters for APC, LLC and MAC

Table 10-1 lists control parameters for the APC, LLC and MAC.

Table 10-1 – Parameters for APC, LLC and MAC

Parameter	Description	Parameter value
T_{IFG_MIN-D}	Default duration of inter-frame gap	29 μ s
$T_{LOWER-IFG_MIN}$	Minimum duration of inter frame gap possible in a TXOP	14 μ s
CYCLE_MIN	Minimum duration of MAC cycle	5 ms
CYCLE_MAX	Maximum duration of MAC cycle	100 ms
TX_ON	A time window after the start of TS during which a transmission can start	1 μ s
TS_DURATION	Duration of time slot	16.64 μ s
T_{ITS}	Duration of idle time slot (ITS) composing the contention window (CW) in CBTS	16.64 μ s
T_{AIFG-D}	Default value of inter-frame gap before Imm-ACK	39.68 μ s
T_{AIFG}	Range of values for inter-frame gap before immediate acknowledgment (Note 2)	5.12 to 39.68 μ s
MIN_SYM_VAR_AIFG_DEFAULT	The default minimum number of symbols following the header required in a frame to use receiver specific T_{AIFG} , instead of T_{AIFG-D} , or $T_{AIFG-DR}$, as the AIFG gap, between the frame and the following immediate acknowledgment. It only applies if the transmitter has no knowledge of the per-receiver MIN_SYM_VAR_AIFG for the receiver	5
T_{RCIFG}	Inter-frame gap between RTS and CTS	29 μ s
T_{CCIFG}	Inter-frame gap between CTS and MSG frame	29 μ s
$T_{BM2BAIFG}$	Inter-frame gap between BMSG and BACK frame	T_{AIFG}
$T_{BA2BMIFG}$	Inter-frame gap between BACK and BMSG frame	T_{AIFG}
T_{BIFG}	Inter-frame gap between MSG frames in PHY frame bursting	Note 1
T_{McAIFG}	Inter-frame gap between multicast ACK frames	5.12 μ s
TICK	The basic MAC resolution (at TXOP level)	10 ns
MAP_TX_SETUP_TIME	The minimum time between the MAP and the MAC cycle it describes	2 ms

Table 10-1 – Parameters for APC, LLC and MAC

Parameter	Description	Parameter value
MAX_ARQ_SLOTS	Maximum number of Mc-ACK slots in multicast acknowledgment	7
DEFAULT_TBFFSS_TIMEOUT	Default timeout used for closing the CBTS in "Timeout-based from frame sequence start" mode	2.5 ms
DEFAULT_TBFCSTIMEOUT	Default timeout used for closing the CBTS in "Timeout-based from CBTS start" mode	2.5 ms
DEFAULT_ERR_CWOI_TIMEOUT	Default timeout for error conditions in "CBTS without INUSE" (see clause 8.3.3.4.5.3 of [ITU-T G.9961])	3.61 ms
REG_RESP_TIME	The maximum time within which the domain master shall respond to registration request (see clause 8.6.1.1.1 of [ITU-T G.9961])	200 ms
REG_RETRY_TIMEOUT	Timeout for node to retry registration (see clause 8.6.1.1.1 of [ITU-T G.9961])	$1\text{ s} + (200\text{ ms} * \text{NUM_HOPS})$ (Note 3)
MAX_REG_ATTEMPTS	Max registration attempts	4
<u>T_{AUTHENTICATION FAILED}</u>	<u>Maximum time to receive an EA_AUTH.IND primitive before considering the authentication of a node failed.</u>	<u>120 s</u>
RES_TIMEOUT	Timeout for resigning node to wait for response from the domain master (see clause 8.6.1.1.3.1 of [ITU-T G.9961])	200 ms
MAX_RES_ATTEMPTS	Max number of resignation attempts	4
CNM_TIMEOUT	Timeout associated with release of connections	200 ms
T _{MCST}	the maximum time the transmitter waits for MC_GrpInfoUpdate.cnf from the multicast group receivers, before it may re-transmit the MC_GrpInfoUpdate.ind message	100 ms
N _{MCST}	Maximum number of retransmissions of the MC_GrpInfoUpdate.ind message	2
TDM_UPDATE	The domain master broadcasts the updated topology information, within this time duration, after receiving topology updates.	100 ms
TN_RSP	A node replies to the request for topology information from the domain master within this time duration, after receiving the request.	100 ms
TUPDATE_MIN	The minimum time a node waits after receiving message TM_DomainRoutingChange.ind from the domain master, before it can send a TM_ReturnDomainTopology.req message to the domain master.	100 ms
INTER_MAP_RMAP_GAP	The minimum gap between the end of a MAP or RMAP frame and the beginning of a subsequent relay of this MAP or RMAP frame.	1 ms
JOIN_INTERVAL_T ₀	The time interval after a node's initialization, during which the node refrains from transmitting and tries to detect MAP frames or RMAP frames associated with the domain that the node intends to join.	10 s

Table 10-1 – Parameters for APC, LLC and MAC

Parameter	Description	Parameter value
JOIN_INTERVAL_T ₂	The time interval after a node becomes DM, during which the node refrains from registering new nodes while sending MAP-Ds to signal its presence to other possible nodes.	400 ms
SYM_BOOST_TYPE	Valid types of symbol boost	00 ₂ , 01 ₂
SYM_BOOST_AMOUNT	Valid amounts of symbol boost	0.0 dB, 0.8 dB
MAX_RESP_TIME	The maximum time within which a node shall respond to the received management message.	100 ms
MAX_WAIT_TIME	The time that a node shall wait for an expected response after transmitting a management message before inferring the loss of the transmitted message or the response from the responding node or both.	200 ms
T _{cshd}	The duration of a contention slot in CBTXOP using DQ-based mechanism	46.08 μs
T _{csfd}	The duration of a contention slot in FDSTXOP	46.08 μs
NOTE 1 – Use of PHY frame bursting for VLC is for further study. NOTE 2 – A receiving node shall choose a value in this range at the time of registration (see clause 8.6.1.1.4.1 of [ITU-T G.9961]). NOTE 3 – See [ITU-T G.9960] for the definition of NUM_HOPS.		

10.3.1 General parameters for management message timeout

See clause 8.4.1 of [ITU-T G.9961].

10.4 Functions of the end-point node

The following paragraphs list the functions of an end-point node.

10.4.1 MAC cycle synchronization and synchronized transmissions

See clause 8.5.1 of [ITU-T G.9961].

10.4.2 Bandwidth reservation

See clause 8.5.2 of [ITU-T G.9961].

10.4.3 Routing of ADPs

For domains operating in CM, see clause 8.5.3 of [ITU-T G.9961]. Domains operating in UM are for further study.

10.4.4 Broadcast of LLC frames

The broadcast of LLC frames only applies to the domain operating in UM.

See clause 8.5.4 of [ITU-T G.9961].

10.4.5 Reporting of detected neighbouring domains

See clause 8.5.5 of [ITU-T G.9961].

10.4.6 MAP relaying

Map relaying only applies to the domain operating in UM.

See clause 8.5.6 of [ITU-T G.9961].

10.4.7 Relaying messages

Relaying messages only applies to the domain operating in UM.

See clause 8.5.7 of [ITU-T G.9961].

10.4.8 Retransmissions and acknowledgement

See clause 8.5.8 of [ITU-T G.9961].

10.4.9 Bidirectional flows

See clause 8.5.9 of [ITU-T G.9961].

10.5 Domain master node functional capabilities

See clause 8.6 of [ITU-T G.9961].

10.5.1 Network admission

ITU-T G.9991 network admission shall follow the procedure specified in clause 8.6.1 of [ITU-T G.9961] with the revised capabilities described in Annex C [and the considerations in Annex D for external authentication](#).

10.5.2 Bandwidth management

See clause 8.6.2 of [ITU-T G.9961].

10.5.3 Synchronization to an external source

See clause 8.6.3 of [ITU-T G.9961].

10.5.4 Routing and topology management

Routing and topology management only applies to the domain operating in UM.

See clause 8.6.4 of [ITU-T G.9961].

10.5.5 Backup domain master

Backup domain master only applies to the domain operating in UM.

See clause 8.6.5 of [ITU-T G.9961].

10.5.6 Domain master selection

Domain master selection only applies to the domain operating in UM.

See clause 8.6.6 of [ITU-T G.9961].

10.5.7 Selection of PHY-frame header segmentation

See clause 8.6.7 of [ITU-T G.9961].

10.5.8 Selection of the DNI and the DOD

See clause 8.6.8 of [ITU-T G.9961].

10.5.9 Per-node transmit PSD shaping

See clause 8.6.9 of [ITU-T G.9961].

10.5.10 Selection of initialization seeds used for generating preamble, PR, INUSE, NACK and IDPS signals

See clause 8.6.10 of [ITU-T G.9961].

10.6 Addressing scheme

10.6.1 Node identifier

See clause 8.7.1 of [ITU-T G.9961].

10.6.1.1 DEVICE_ID

See clause 8.7.1.1 of [ITU-T G.9961].

10.6.1.2 MULTICAST_ID and BROADCAST_ID

MULTICAST_IDs shall be generated autonomously by the nodes creating multicast groups for the multicast transmission. MULTICAST_IDs only apply to multicast transmissions among nodes communicating directly (i.e., not via a relay node). A node shall generate a unique MULTICAST_ID for each multicast group that it creates. The node creating the multicast group shall communicate the MULTICAST_ID to all multicast destination nodes using the protocol described in clause 10.25 before starting the multicast transmission. As the multicast session is complete, nodes shall terminate the MULTICAST_ID according to an explicit notification from the node creating the multicast group (see clause 8.16).

A node may be addressed by multiple MULTICAST_IDs generated by different nodes for a multicast transmission to this node. The same MULTICAST_ID can be used as the DID by several nodes for different multicast groups. The differentiation in the receiver is by the SID of the node creating the multicast group.

The MULTICAST_ID shall be represented by an 8-bit unsigned integer with valid values in the range from 1 to 254. It is distinguished from a DEVICE_ID in the PHY-frame header and in the MAP by the multicast indicator described in clause 7.1.2.3.1.5 of [ITU-T G.9960].

A BROADCAST_ID is a MULTICAST_ID with a fixed value of 255 and shall be used for broadcast transmission only.

Table 10-2 – Definition and valid values of node identification parameters

Parameter	Valid values	Description
DEVICE_ID	0	The ID used by a new node joining the network before it is assigned a unique DEVICE_ID by the domain master. The domain master shall not assign the DEVICE_ID = 0 to any node admitted to the network.
	1 to 250	IDs reserved for assignment by the domain master to nodes admitted to the network.
	251	The ID used for inter-domain communication
	252	The ID used for the feedback notification transmitted in the FDSTXOP.
	253 to 255	Reserved by ITU-T
MULTICAST_ID	0	Reserved by ITU-T
	1 to 254	IDs reserved for assignment for multicast traffic
BROADCAST_ID	255	A special value of MULTICAST_ID reserved for broadcast traffic.

10.6.2 Flow identifier (FLOW_ID)

See clause 8.7.2 of [ITU-T G.9961].

10.7 Medium access plan (MAP) frame

See clause 8.8 of [ITU-T G.9961].

10.7.1 MAP generation and distribution

See clause 8.8.1 of [ITU-T G.9961].

10.7.2 MAP frame transmission

See clause 8.8.2 of [ITU-T G.9961].

10.7.3 MAP header

See clause 8.8.4.3 of [ITU-T G.9961].

10.7.4 TXOP descriptor

Each TXOP is described by at least one TXOP descriptor. A TXOP descriptor is composed of a basic TXOP descriptor that may be extended by one or more additional TXOP descriptor extensions (see clauses 10.7.4.1.1 to 10.7.4.1.8). TXOP descriptor extensions supply additional information like scheduling information, timing information and TXOP attributes.

A TXOP descriptor shall only allow transmissions using Profile 1 OFBs (e.g., using the PHY layer in clause 7 of [ITU-T G.9960]). The DM shall ensure that all nodes that transmit in a given TXOP have the right capabilities and shall set the field ALLOWED OFB to the appropriate value (see Table 8-63 of [ITU-T G.9961]).

Basic TXOP descriptors and TXOP descriptor extensions are each four octets in length.

A TXOP descriptor represents the right of a certain node or a set of nodes to transmit within a certain TXOP. A CFTXOP shall be described using a single TXOP descriptor. A CBTXOP shall be described by either a single TXOP descriptor or by multiple TXOP descriptors (see clause 10.2.2.1). A STXOP shall be described using several TXOP descriptors representing the TSs within the STXOP. An FDSTXOP and an FDCFTXOP shall be described using a basic TXOP descriptor and an addition TXOP descriptor extensions.

The domain master shall not assign more than 127 TXOP descriptors in the MAP, describing TSs, within a single STXOP (including CBTXOP).

The differentiation between different TXOPs shall be done via the TXOP attributes extension, which shall be appended to the last TXOP descriptor of a TXOP. The TXOP attributes extension supplies the timing information for the TXOP (see clause 10.7.4.1). A node associated with a TXOP or a TS is uniquely identified in a TXOP descriptor by the *SID* field, which shall be set to the *DEVICE_ID* of the node as was assigned by the domain master.

A flow associated with a TXOP or a TS is uniquely identified in a TXOP descriptor by the combination (*SID*, *FLOW_ID*). A *FLOW_ID* is a unique identifier of a flow associated with the *SID*.

A user priority associated with a TXOP or TS is uniquely identified in a TXOP descriptor by the tuple (*SID*, *PRI*). The *PRI* value shall represent the lowest MPDU priority that may be sent in the TXOP or TS.

A special TXOP is specified for assignment to nodes for transmitting traffic associated with a bandwidth managed DLL multicast stream. These TXOPs are assigned to a DLL multicast stream by using the 'Multicast Indication' field in the basic TXOP descriptor, combined with the 'FLOW_ID/PRI/MSID' field in the basic TXOP descriptor to identify the MSID of the stream and the 'SID' field in the basic TXOP descriptor to identify an intermediate node in the DLL multicast stream that is responsible for the transmission of data associated with the DLL multicast stream. The 'DID/Originating Node' field in the TXOP descriptor shall contain the originating node of the DLL multicast stream and together with the MSID field, uniquely identifies the DLL multicast stream in the domain.

The differentiation between the full duplex TXOPs (FDSTXOP and FDCFTXOP) and the half duplex TXOPs shall be done via the 'FD TXOP Indicator' field in the basic TXOP descriptor. If the 'FD

TXOP Indicator' field in the basic TXOP descriptor is set to '0', then it is a half duplex TXOP; otherwise, it is a full duplex TXOP. The differentiation between the FDSTXOP and the FDCFTXOP shall be done via the additional TXOP descriptor extensions (see clauses 10.7.4.1.6 and 10.7.4.1.7).

Table 10-3 describes the basic TXOP descriptor. When the extension bit is set, the TXOP descriptor shall have an extension, as described in clause 10.7.4.1. Different types of TXOP descriptor extensions are distinguished by extension type.

Table 10-3 – Basic TXOP descriptor format

Field	Octet	Bits	Description
SID	0	[7:0]	SID = 1-250 identifies the DEVICE_ID of the node assigned to the TXOP. SID = 0, 255 indicates special values for the TXOP descriptor (see clause 10.7.4.2). If this TXOP is an FDSTXOP, the SID is the DEVICE_ID of the central node.
DID/Originating Node	1	[7:0]	If Multicast Indication = 0: <ul style="list-style-type: none"> • DID = 0 indicates that the DID of the destination node of the flow is not known to the domain master. • DID > 0 indicates the destination node for the flow. DID shall be set to the DEVICE_ID. If this TXOP is an FDSTXOP, the DID shall be set to 252. If Multicast Indication = 1: This field identifies the originating node of the DLL multicast stream for which this TXOP is assigned.
Multicast Indication/MAP type	2 and 3	[0]	If this field is a special TXOP descriptor of a MAP (see clause 10.7.4.2) it indicates the type of MAP that shall be transmitted: 0 indicates MAP-A, 1 indicates MAP-D. If this field is not a special TXOP descriptor of a MAP this field contains the multicast indication: 1 indicates multicast/broadcast DID, 0 otherwise.
PR signal required		[1]	This bit instructs nodes contending for transmission in a CBTS whether to use the PR signal: 0 – PR signal shall not be used. 1 – PR signal is required.
CBTS Closure Mode		[3:2]	This field instructs nodes where to close a CBTS that was used for transmission (see in clause 10.2.2.1): 00 – Duration-based. 01 – Timeout-based from frame sequence start. 10 – Timeout-based from CBTS start. 11 – Reserved by ITU-T.
FD TXOP Indicator		[4]	This field indicates whether this is a TXOP for half duplex transmission or a TXOP for full duplex transmission. 0 – CFTXOP or CBTXOP or STXOP. 1 – FDSTXOP or FDCFTXOP.
CBTXOP Indicator		[5]	This field indicates whether this is a CBTXOP using the contention mechanism as described in clause 10.2.2.3.4 or using the contention mechanism as described in clause 10.2.2.3.8.

Table 10-3 – Basic TXOP descriptor format

Field	Octet	Bits	Description
			0 – using the contention mechanism as described in clause 10.2.2.3.4. 1 – using the contention mechanism as described in clause 10.2.2.3.8.
FlowID/PRI/MSID		[13:6]	If Multicast Indication = 0: <ul style="list-style-type: none"> Identifies the flow or the user priority associated with the TXOP/TS. Valid values for user priority assignments are 0-7 Valid values for FLOW_ID assignments are 8-250 If Multicast Indication = 1: <ul style="list-style-type: none"> Valid values for MSID assignments are 1-250 Value 0 is reserved by ITU-T Values 251- 254 are reserved by ITU-T Value 255 indicates special values for the TXOP descriptor (see clause 10.7.4.2). If this TXOP is an FDSTXOP or an FDCFTXOP, the FlowID/PRI corresponds to FlowID/PRI of the primary transmission. If this TXOP is a CBTXOP with the CBTXOP indicator set to one, the FlowID/PRI shall set to zero.
Last_in_Group		[14]	1 indicates the last TS of a group of TSs in STXOP, 0 otherwise. Shall be set to zero for CFTXOP, CBTXOP using the contention mechanism as described in clause 10.2.2.3.8, FDCFTXOP and FDSTXOP.
Extension		[15]	0 – No extension is present. 1 – This TXOP descriptor contains an extension.

Several TSs within the same STXOP can be grouped together to specify common attributes for these TSs via a group information extension (see clause 10.7.4.1). Grouping of several TSs shall be done by setting the Last_in_Group indication in the TXOP descriptor of the last TS of the group. Groups are implicitly numbered according to their appearance in the MAP. The first group shall be identified as group number one and so on. If a group contains only one TS, the descriptor of this TS shall have its Last_in_Group bit set to one.

10.7.4.1 TXOP descriptor extension

All TXOP descriptor extensions shall be of 4 octets and shall have the format described in Table 10-4. A TXOP descriptor may have more than one extension.

Table 10-4 – TXOP descriptor extension format

Field	Octet	Bits	Description
Extension data	0 to 3	[26:0]	Extension data (see clauses 10.7.4.1.1 to 10.7.4.1.8).
Extension Type		[30:27]	TXOP descriptor extension type: 0 – TXOP attributes (see clause 10.7.4.1.2). 1 – TXOP absolute timing (see clause 10.7.4.1.3). 2 – Group information (see clause 10.7.4.1.4).

Table 10-4 – TXOP descriptor extension format

Field	Octet	Bits	Description
			3 – Maximum transmission limitation (see clause 10.7.4.1.5). 4 – CBTS nodes information (see clause 10.7.4.1.6). 5 – Additional TXOP attributes (see clause 10.7.4.1.7). 6 – FD contention-free information (see clause 10.7.4.1.8). 7 – FD contention group information (see clause 10.7.4.1.9). 8–15 – Reserved by [ITU-T G.9961] 9-15 – Reserved by ITU-T.
Extension		[31]	0 – No more extensions present. 1 – This TXOP descriptor contains more extensions.

10.7.4.1.1 TXOP attributes extension data

See clause 8.8.4.1.1 of [ITU-T G.9961].

10.7.4.1.2 TXOP absolute timing extension data

See clause 8.8.4.1.2 of [ITU-T G.9961].

10.7.4.1.3 Group information extension data

See clause 8.8.4.1.3 of [ITU-T G.9961].

10.7.4.1.4 Maximum transmission limitation extension data

See clause 8.8.4.1.4 of [ITU-T G.9961].

10.7.4.1.5 CBTS nodes information extension data

A CBTS nodes information extension shall be identified by extension type 4 and shall be used to specify the specific list of nodes that are allowed to contend in a particular CBTS as specified via a TXOP descriptor (see clause 10.7.4.1). The list of nodes shall be described by indicating the DEVICE_IDS. Several CBTS nodes information extension may be used for a TXOP descriptor that describes a CBTS.

In a CBTXOP using the contention mechanism described in clause 10.2.2.3.8, the specific list of nodes that are allowed to contend in each CBTS shall be the same, therefore only one CBTS nodes information extension shall be used for the CBTXOP descriptor.

The CBTS nodes information extension is described in Table 10-5.

Table 10-5 – CBTS nodes information Extension Data format

Field	Octet	Bits	Description
Include_Exclude	0	[0]	0 – All nodes indicated in the following entries may contend in this CBTS 1 – All nodes indicated in the following entries shall not contend in this CBTS
Entry format		[1]	0 – byte map format 1 – bit map format
Reserved		[7:2]	Reserved by ITU-T (Note)
Byte map format			
Entry number 1	1	[7:0]	0 = New nodes joining network

Table 10-5 – CBTS nodes information Extension Data format

Field	Octet	Bits	Description
			1 to 250 identifies the DEVICE_ID of a registered node 251 to 254 – Reserved by ITU-T 255 – This entry shall be ignored
Entry number 2	2	[7:0]	0 = New nodes joining network 1 to 250 identifies the DEVICE_ID of a registered node 251 to 254 – Reserved by ITU-T 255 – This entry shall be ignored
Reserved	3	[2:0]	Reserved by ITU-T (Note)
Extension Type and Extension		[7:3]	See Table 8-64
Bit map format			
Entry number 1	1	[7:0]	0 – New nodes joining network 1-250 identifies the DEVICE_ID of a registered node 251-255 – Reserved by ITU-T
Entry number 2	2	[0]	Identifies status for DEVICE_ID= Entry number 1 + 1 0 – Node included in the list 1 – Node not included in the list
Entry number 3		[1]	Identifies status for DEVICE_ID= Entry number 1 + 2 0 – Node included in the list 1 – Node not included in the list
...	
Entry number 8		[6]	Identifies status for DEVICE_ID= Entry number 1 + 7 0 – Node included in the list 1 – Node not included in the list
Entry number 9		[7]	Identifies status for DEVICE_ID= Entry number 1 + 8 0 – Node included in the list 1 – Node not included in the list
Reserved	3	[2:0]	Reserved by ITU-T (Note)
Extension Type and Extension		[7:3]	See Table 8-64
NOTE – Bits that are reserved by ITU-T shall be set to zero by the transmitter and ignored by the receiver.			

10.7.4.1.6 Additional TXOP attributes extension data

See clause 8.8.4.1.6 of [ITU-T G.9961].

10.7.4.1.7 FD contention-free information extension data

This clause is for further study.

10.7.4.1.8 FD contention group information extension data

An FD contention group information extension shall be identified by extension type 8 and shall be used to specify the specific list of nodes that are allowed to contend in the FDSTXOP using the DQ contention access mechanism (see clause 10.2.2.5). The list of nodes shall be described by indicating the DEVICE_IDs. Only nodes that are on this list shall be allowed to contend to be the secondary

transmitter of the full duplex transmission and send MSG frames to the central node in this FDSTXOP.

The FD contention group information extension is described in Table 10-6.

Table 10-6 – FD contention group information Extension Data format

Field	Octet	Bits	Description
Entry Number	0	[7:0]	The total number that are allowed to contend in the FDSTXOP
Entry number 1	1	[7:0]	The DEVICE_ID of the first node that is allowed to contend in the FDSTXOP
Entry number 2	2	[7:0]	The DEVICE_ID of the second node that is allowed to contend in the FDSTXOP
...	var
Entry number N		[7:0]	The DEVICE_ID of the N th node that is allowed to contend in the FDSTXOP
Reserved	var	[2:0]	Reserved by ITU-T (Note)
Extension Type and Extension		[7:3]	See Table 10-4

NOTE – Bits that are reserved by ITU-T shall be set to zero by the transmitter and ignored by the receiver.

10.7.4.2 Special values for the TXOP descriptor

See clause 8.8.4.2 of [ITU-T G.9961].

10.7.5 Auxiliary information field

See clause 8.8.5 of [ITU-T G.9961].

10.7.6 MAP schedule persistence publication

See clause 8.8.6 of [ITU-T G.9961].

10.8 Retransmission and acknowledgement protocol

See clause 8.9 of [ITU-T G.9961].

10.9 Management and control message format

See clause 8.10 of [ITU-T G.9961].

10.10 Channel estimation protocol

See clause 8.11 of [ITU-T G.9961].

10.11 Connection management

See clause 8.12 of [ITU-T G.9961].

10.12 Operation in the presence of neighbouring domains

This clause is for further study.

10.13 Inter-domain mobility support

10.13.1 Inter-domain mobility through external control

10.13.1.1 Introduction

In some network architectures, the mobility of an end point between different domain masters may be decided by an external controller. In this architecture, VLC nodes provide this external controller with all the information necessary to decide and perform the mobility of the VLC node from a domain to a different domain.

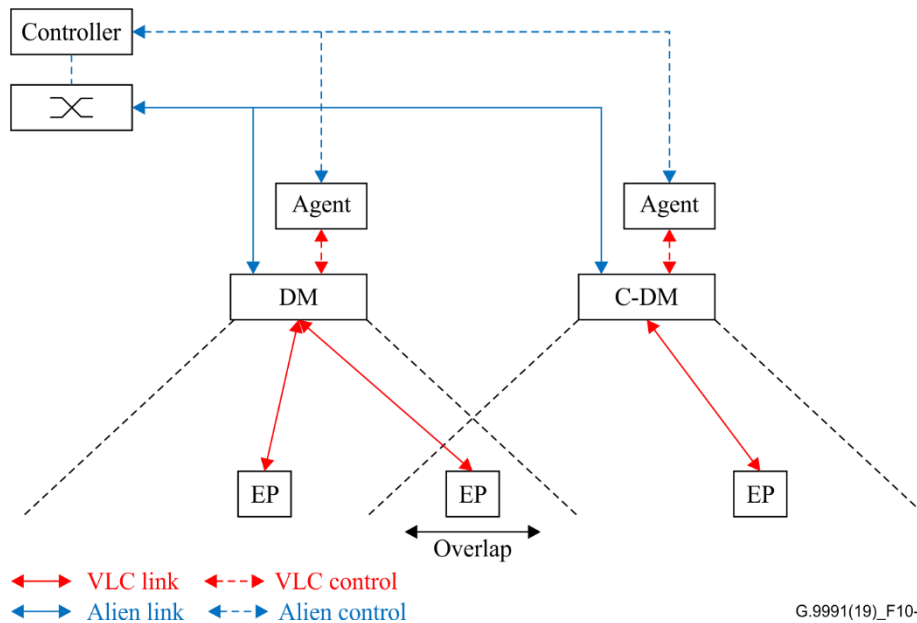

Figure 10-8 – Controller-based architecture for inter-mobility support

The exchange of this information between the domain master and the controller may be done directly or through external agents.

The definition of the external controllers and agents are out of scope of this Recommendation.

The domain master of a domain that provides this inter-domain mobility shall provide to the external controller (or agents) the metrics for the following links (see clause 10.13.1.2):

- link between the DM and each of the end points of its domain;
- link between the EPs in its domain and any other possible candidate DM that the end point may see.

This information shall be made available through the LCMP protocol (see clause 10.23).

10.13.1.2 Metrics acquisition

A DM shall measure the characteristics of the different links that are related to the inter-domain mobility support.

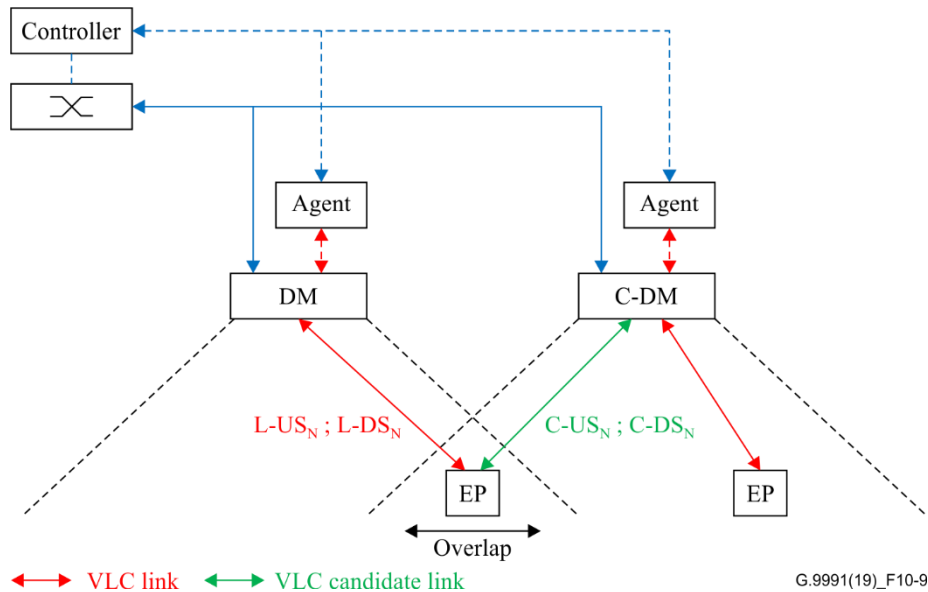

Figure10-9 – Metrics to be provided by the DM for each EP

NOTE – In Figure 10-9 only one candidate DM is shown (DM2), however, several candidates and therefore several tuples C-US; C-DS may exist.

- **L-US_N**: Estimation of the channel of the link between the EP that may need to roam and the DM: In this case, it is a normal channel estimation within a domain, therefore, the DM may use any of the mechanisms described in this Recommendation for estimating the channel (see clause 10.10).
- **L-DS_N**: Estimation of the channel of the link between the DM and the DM that needs to roam: In this case, it is a normal channel estimation within a domain. The DM can use any of the mechanisms described in the Recommendation for estimating the channel. However, it is likely that it will need a transmitter-triggered channel estimation (see clause 10.10).
- **C-US_N**: Estimation of the channel of the link between the EP that may need to roam and a new candidate DM: In this case, the candidates DMs use the MAP-Ds sent in the IDCC channel by each of the EPs (on demand by the DM of their domain). The DM of the EPs in this transition zones should assign more MAP-D transmissions in the IDCC.
- **C-DS_N**: Estimation of the channel of the link between a candidate DM and an EP that needs to roam: In this case, the EP may use the candidate DM MAP-D sent in the IDCC for channel estimation and report the measured information to its DM (see clause 10.4.5).

10.13.1.3 Fast transition of security mechanisms

This clause is for further study.

10.13.1.4 Interface with alien controller

The interface with alien controller shall be done through the L6 interface as defined in clause 10.23 and [ITU-T G.9962].

However, the data models to be used shall follow annexes A and B of this Recommendation for L1 and L6 interfaces, respectively.

10.14 Dimming support and flicker avoidance

10.14.1 Dimming support

This Recommendation provides support for dimming technologies. However, this support varies depending on the PHY.

When using a PHY based on [ITU-T G.9960] (see clause 8), the modulation does not guarantee a positive real modulated signal and therefore clipping may occur when using dimming techniques. However, this Recommendation specifies adaptive mechanisms that may be used to mitigate performance losses for deep levels of dimming.

When using a PHY based on ACO-OFDM (see clause 9), the modulation used guarantees a positive real modulated signal that is added to the bias current in the LED. This way, during dimming no performance loss is coming from the modulation itself.

10.14.2 Flicker avoidance

An ITU-T G.9991 system modulates the signal at very high frequency therefore no flicker is generated by the modulated signal itself. However, for low speed transitions between states (transmission state to non-transmission state), flicker shall be considered by the designer when implementing the scheduling if the average current injected into the medium is different for the two states.

NOTE – ITU-T G.9991 systems should follow the guidelines provide in [b-IEEE 1789-2015] to avoid flicker.

10.15 Inter-~~bandplan~~-OFB interoperability

See clause 8.18 of [ITU-T G.9961].

10.16 MIMO transmission

This clause is for further study.

10.17 Operation with non-VLC uplink

For further study.

10.18 DLL multicast stream

See clause 8.17 of [ITU-T G.9961].

10.19 Node information and capabilities exchange

See clause 8.19 of [ITU-T G.9961].

10.20 Metrics acquisition protocol

See clause 8.20 of [ITU-T G.9961].

10.21 Operation in power saving modes

See clause 8.21 of [ITU-T G.9961].

10.22 Layer 2 configuration and management protocol

See clause 8.22 of [ITU-T G.9961].

10.23 Payload compression in management messages

See clauses 8.24 and X.3 of [ITU-T G.9961].

10.24 TLV Pool

See clause 8.25 of [ITU-T G.9961].

10.25 PHY multicast binding protocol

See clause 8.16 of [ITU-T G.9961].

11 Security

See clause 9 of [ITU-T G.9961].

12 Management of ITU-T G.9991 nodes

12.1 Architecture and reference model

12.1.1 Architecture

A model of the ITU-T G.9991 management, control and security (MCS) architecture is depicted in Figure 12-1. The model consists of various entities located either within nodes, within a domain or external to the domain. MCS entities provide management, control and security of the layer they reside in as well as services and interfaces to enable MCS communications.

The structure of MCS begins with the layers of the node; the physical (PHY) layer and the data link layer (DLL). Each of these has a specific MCS entity. Above these in the MCS hierarchy, but still within Layer 2, is the node management entity (NME), which is responsible for managing the node's overall functions. Outside of the node are two entities that reside in the same domain as the node. These are the security controller entity (SCE) and the domain master management entity (DMME). These manage and control their specific areas of responsibility (e.g., security for the SCE) within the domain. These two entities are still within Layer 2 as they are solely functioning to facilitate Layer 2 activities. These two entities are considered to operate at the domain level, unlike the node located ones that operate at the node or device level. The next entity is the global master entity (GME). This entity is defined as external to the domain, performing management and control functions for all domains within a specific home network. Global master (GM) functions are logical and able to be distributed among its managed domain masters (DMs). As GM functions concern actions that span multiple domains within a common network, it is referenced as operating at the network level for logical representation of its place in the MCS hierarchy. This is an arbitrary assignment given the logical nature of the GM. Entities that perform functions above the security controller (SC) and the GM or, in its absence the DM, are considered to be non-ITU-T G.9991 entities and out of scope. They are described in summary here as they may exist and effect the operation of the entities lower than them in the hierarchy.

The SC and DM are depicted as separate entities as they might or might not be located within the same device and might or might not be associated with the same node.

NOTE – The SC itself may be a proxy function versus a standalone entity, as it may be only a local presence of a remote authenticating system/entity that is out of scope of this Recommendation. The internal operation and structure of the SC is as well out of scope; only its operations facing into the domain are within scope of this Recommendation, such operations as represented by its messaging and functions as described in clauses 8 and 9.

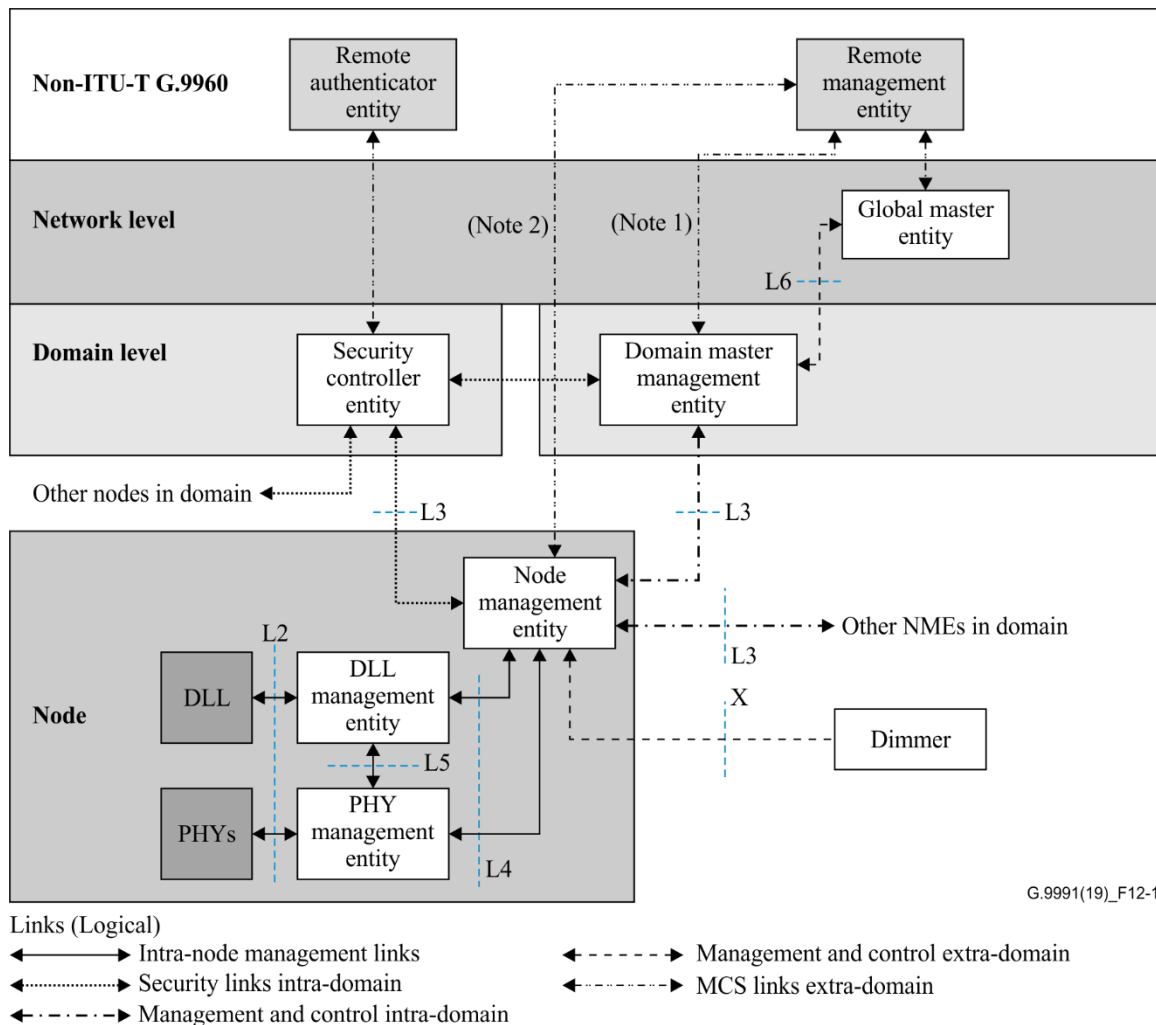

NOTE 1 – In the absence of a GME or when the GM functions are distributed, the DMME may communicate directly with the remote management entity.

NOTE 2 – The remote management entity may communicate with select nodes using specific read/write functions.

Figure 12-1 – Architecture of management, control and security

At the device level within the same domain, management and control messages are exchanged between node NMEs and between node NMEs and application entities (AEs).

An AE may exchange management and control messages with the NME in its device or with another node's NME in the same domain (L1 interface) using the LCMP protocol (see clause 10.23). Nodes exchange management and control messages between NMEs to facilitate communications between nodes (L3 interface). These interactions are illustrated in Figure 12-2.

Specific AE to AE communications are outside the scope of this Recommendation.

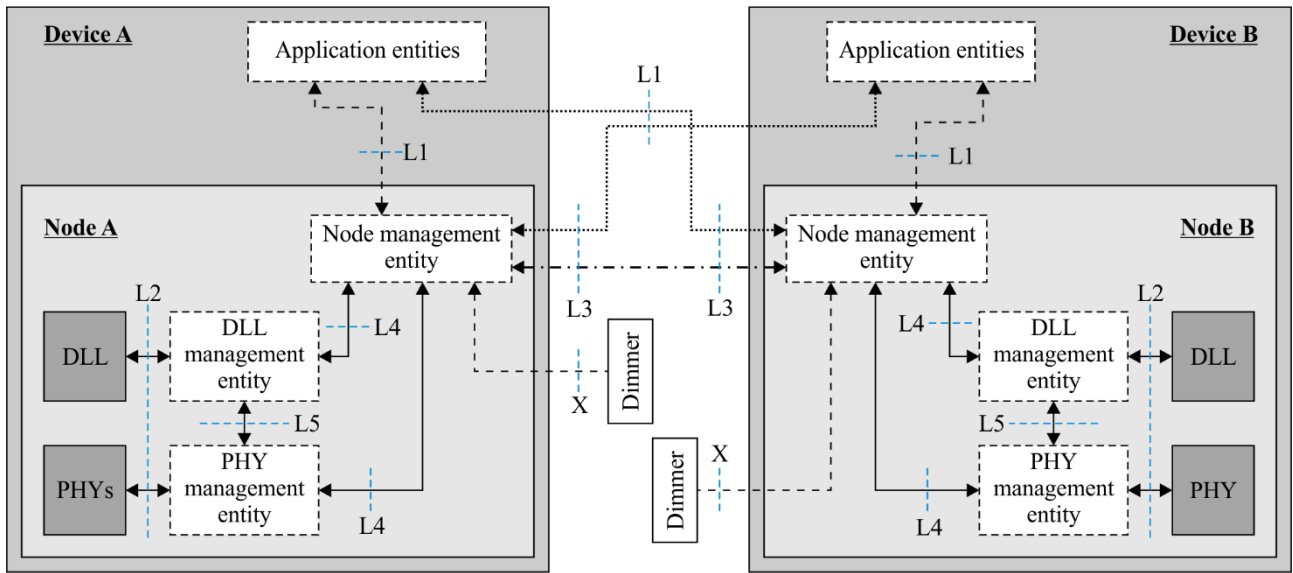

Device level management links (logical)

- ◄-----► Inter-device AE to/from far node
- ◄-----► Inter-device node to node
- ◄-----► Intra-device AE to/from far node

Figure 12-2 – Device level management links

12.1.1.1 Overall MCS structure

See clause 6.1.1 of [ITU-T G.9962].

12.1.1.2 Management and control entities

See clause 6.1.2 of [ITU-T G.9962].

12.1.2 Reference model

Figure 12-3 illustrates data-plane, control-plane and management-plane reference models for an ITU-T G.9991 transceiver.

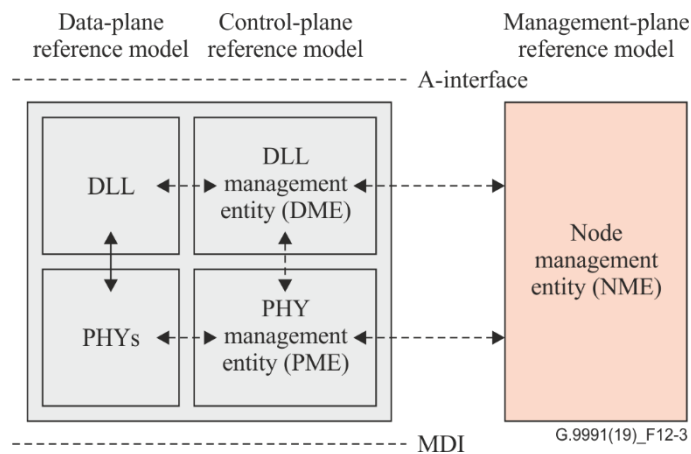

Figure 12-3 – ITU-T G.9991 reference model

12.2 ITU-T G.9991 interface data model

This clause is for further study.

Annex A

LCMP communication through L1 interface

(This annex forms an integral part of this Recommendation.)

A.1 LCMP_CONTROL in L1 interface

LCMP frames conveying information via the L1 interface shall use 0_{16} as LCMP_CONTROL.

A.2 Data model for L1 interface

For further study.

Annex B

LCMP communication through L6 interface

(This annex forms an integral part of this Recommendation.)

B.1 LCMP_CONTROL in L6 interface

LCMP frames conveying information via the L6 interface shall use 5₁₆ as LCMP_CONTROL.

B.2 Data model for L6 interface

Table B-1 – [ITU-T G.9961] L6 interface parameters

Parameter	Param ID	Access type	Parameter value field
EPmetrics	00 ₁₆	R	See clause B.2.1

B.2.1 EP metrics

Table B-2 – Format of the EPMetrics parameter

Field	Octet	Bits	Description
Number of end points	0	[7:0]	Number of reported end point nodes (N).
EPIdentification[0]	1	[7:0]	Identification of the reported node. It shall be formatted as described in Table B-3.
LocalLinkMetrics[0]	2-5	[31:0]	Reported performance metrics for the link between the reported end point and its DM. It shall be formatted as described in Table B-4.
CandidateLinkMetrics[0]	Var	Var	Reported performance metrics for the link between the reported end point and each of the candidate DMs. It shall be formatted as described in Table B-5.
...
EPIdentification[N-1]	Var	Var	Identification of the reported node. It shall be formatted as described in Table B-3.
LinkMetrics[N-1]	Var	Var	Reported performance metrics for the link between the reported end point and its DM. It shall be formatted as described in Table B-4.
CandidateLinkMetrics[N-1]	Var	Var	Reported performance metrics for the link between the reported end point and each of the candidate DMs. It shall be formatted as described in Table B-5.

Table B-3 – Format of EPIdentification field

Field	Octet	Bits	Description
DEVICE_ID	0	[7:0]	DEVICE_ID of the node
MAC	1 to 6	[47:0]	MAC address of the node

Table B-4 – Format of LinkMetrics fields

Field	Octet	Bits	Description
BitsPerSecond	0-3	[31:0]	Bits [15:0] indicate the PHY data rate in bits per second from the reporting node to the detected node; Bits [31:16] indicate the PHY data rate from the detected node to the reporting node. (Note)
<p>NOTE – Calculation shall follow the formula $\sum_{i=1}^N \text{BitsPerSecond}_i * \frac{T_i}{T_{\text{Cycle}}}$ where N is the number of channel estimation windows in the MAC cycle, BitsPerSecond_i is the result of applying the same formula as Note 2 in Table 8-33 of [ITU-T G.9961] to the i-th channel estimation window, T_i is the duration of the i-th channel estimation window and T_{Cycle} is the duration of the MAC cycle. If no channel estimation is available for a particular window, RCM parameters shall be used for that window. If the data rate with the particular detected node is not available, the value of this parameter shall be set to FFFF₁₆.</p>			

Table B-5 – Format of CandidateLinkMetrics fields

Field	Octet	Bits	Description
Number of candidate DMs	0	[7:0]	Number of candidates DMs reported by this node (M)
LinkIdentification[0]	0-6	[56:0]	Identification of the node with which the link is measured (detected node) It shall be formatted as described in Table B-3
BitsPerSecond[0]	7-9	[31:0]	Bits [15:0] indicate the PHY data rate in bits per second from the reporting node to the detected node; Bits [31:16] indicate the PHY data rate from the detected node to the reporting node. (Note)
...
LinkIdentification[M-1]	0-6	[56:0]	Identification of the node with which the link is measured (detected node) It shall be formatted as described in Table B-3.
BitsPerSecond[M-1]	7-9	[31:0]	Bits [15:0] indicate the PHY data rate in bits per second from the reporting node to the detected node; Bits [31:16] indicate the PHY data rate from the detected node to the reporting node. (Note)
<p>NOTE – Calculation shall follow the formula $\sum_{i=1}^N \text{BitsPerSecond}_i * \frac{T_i}{T_{\text{Cycle}}}$ where N is the number of channel estimation windows in the MAC cycle, BitsPerSecond_i is the result of applying the same formula as Note 2 in Table 8-33 of [ITU-T G.9961] to the i-th channel estimation window, T_i is the duration of the i-th channel estimation window and T_{Cycle} is the duration of the MAC cycle. If no channel estimation is available for a particular window, RCM parameters shall be used for that window. If the data rate with the particular detected node is not available, the value of this parameter shall be set to FFFF₁₆.</p>			

Annex C

ITU-T G.9991 Capabilities

(This annex forms an integral part of this Recommendation.)

C.1 ITU-T G.9991 capabilities

ITU-T G.9991 specific capabilities shall be in the range A₀₁₆ to AF₁₆.

Table C.1 – List of ITU-TG.9991-specific capabilities

Capability type	Capability name	Capability length value	Capability value field
A ₀₁₆	Wavelength support	Var	See Table C.1.1
A ₁₁₆	Dimming support	1	See Table C.1.2
A ₂₁₆	PHY support	1	See Table C.1.3
A ₃₁₆	Spectrum support	1	See Table C.1.4
A ₄₁₆ -AF ₁₆	Reserved by ITU-T		Reserved by ITU-T

NOTE – Bits that are reserved by ITU-T shall be set to zero by the transmitter and ignored by the receiver.

Table C.1.1 – Wavelength support

Field	Octet	Bits	Description
Transmission peak wavelengths	Var	Var	List of individual peak wavelengths attached to this device for transmission (Note) See Table C.1.1.1.
Reception peak wavelengths	Var	Var	List of individual peak wavelengths attached to this device for reception (Note) See Table C.1.1.1.

NOTE – See [b-IEC 62504:2014] for the definition of peak wavelength.

Table C.1.1.1 – Peak wavelength list

Field	Octet	Bits	Description
Number of peak wavelengths	0	[7:0]	Number of devices with individual peak wavelengths attached to this device (N) coded as an unsigned integer from 1 to 254. Values 0 and 255 are reserved by ITU-T.
PeakWl[0]	1 and 2	[11:0]	First peak wavelength attached to this node (Note 2) coded as an unsigned integer representing nanometres.
Reserved		[15:12]	Reserved by ITU-T (Note 1).
...
PeakWl[N-1]	Var	[11:0]	Last peak wavelength attached to this node (Note 2) coded as an unsigned integer representing nanometres.
Reserved		[15:12]	Reserved by ITU-T (Note 1).

NOTE 1 – Bits that are reserved by ITU-T shall be set to zero by the transmitter and ignored by the receiver.
NOTE 2 – Peak wavelength is in the range of 200 nm to 1200 nm.

Table C.1.2 – Dimming support

Field	Octet	Bits	Description
ExtendedDimmingSupport	0	[0]	If set to one, the node supports the improved supported dimming range mechanism described in clause 8.1.4.4.7; set to zero otherwise.
Reserved	0	[7:1]	Reserved by ITU-T (Note).
NOTE – Bits that are reserved by ITU-T shall be set to zero by the transmitter and ignored by the receiver.			

Table C.1.3 – PHY support

Field	Octet	Bits	Description
PHYSupport	0	[3:0]	Bitmap indicating the support of the PHY layers described in this Recommendation. If set to one, indicates support for that particular PHY layer. Bit 0 (LSB): G.9961-based OFDM Bit 1: ACO-OFDM Bit 2: Reserved by ITU-T Bit 3: Reserved by ITU-T
Reserved	0	[7:4]	Reserved by ITU-T (Note)
NOTE – Bits that are reserved by ITU-T shall be set to zero by the transmitter and ignored by the receiver.			

Table C.1.4 – Spectrum support

Field	Octet	Bits	Description
PMSCUsed	0	[0]	If set to one, this node allows the use of the subcarriers 0 to 10 for transmission.
Reserved	0	[7:1]	Reserved by ITU-T (Note).
NOTE – Bits that are reserved by ITU-T shall be set to zero by the transmitter and ignored by the receiver.			

C.2 Excluded ITU-T G.9961 capabilities

The ITU-T G.9961 capabilities (see Table 8-16.5 of [ITU-T G.9961]) listed in Table C.2 shall not be used in an ITU-T G.9991 network.

Table C.2 – List of ITU-T G.9961 capabilities not applicable to ITU-T G.9991

Capability type	Capability name
05 ₁₆	Run-Length Compression Support
A0₁₆	Profile 2 OFBs Info
A3₁₆	Payload encoding for Profile 2 OFBs Capabilities

Annex D

IEEE 802.1X port-based network access control

(This annex forms an integral part of this Recommendation.)

See Annex D of [ITU-T G.9961] with the following revision:

Specific NN keys derivation performed by the security controller shall be:

- NN keys used between a node (N) and an access point (AP) have the same value ($NN = NN_{AB} = NN_{BA}$) derived using the following formula:

$NN = \text{PRF-X}(\text{NSC}_N, \text{"Pairwise key expansion"} \parallel \text{MAC}_N \parallel \text{MAC}_{AP} \parallel \text{DID}_N \parallel \text{DID}_{AP} \parallel \text{Nonce})$

- NN keys used between two nodes (A and B) have the same value ($NN = NN_{AB} = NN_{BA}$) derived using the following formula:

$NN = \text{PRF-X}(\text{NSC}_A, \text{"Pairwise key expansion"} \parallel \text{MAC}_A \parallel \text{MAC}_B \parallel \text{DID}_A \parallel \text{DID}_B \parallel \text{Nonce})$

Appendix I

Introducing a DC offset when using a PHY layer based on Recommendation ITU-T G.9960

(This appendix does not form an integral part of this Recommendation.)

Figures I.1 and I.2 show an example on how to introduce a DC component to the modulated signal in order to connect an ITU-T G.9991 system using a PHY layer based on [ITU-T G.9960] (see clause 8) to the optical transceivers.

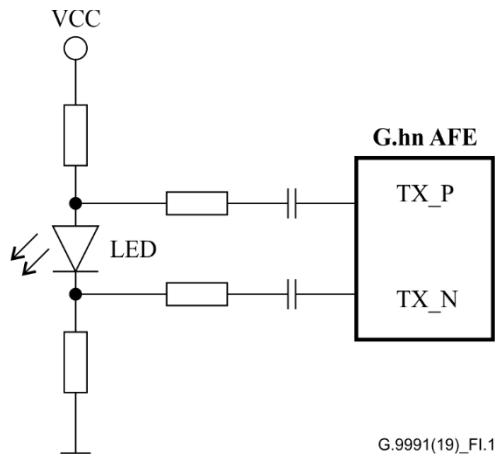

Figure I.1 – Block diagram for the transmit side

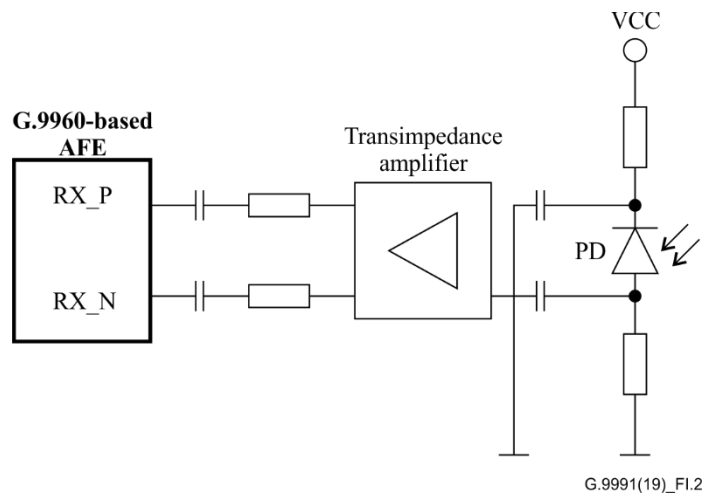

Figure I.2 – Block diagram for the receiver side

Bibliography

- [b-IEEE 1789] IEEE 1789-2015, *IEEE Recommended Practices for Modulating Current in High-Brightness LEDs for Mitigating Health Risks to Viewers.*
- [b-IEC 62504] IEC 62504-2014, *General lighting – Light emitting diode (LED) products and related equipment – Terms and definitions.*

SERIES OF ITU-T RECOMMENDATIONS

Series A	Organization of the work of ITU-T
Series D	Tariff and accounting principles and international telecommunication/ICT economic and policy issues
Series E	Overall network operation, telephone service, service operation and human factors
Series F	Non-telephone telecommunication services
Series G	Transmission systems and media, digital systems and networks
Series H	Audiovisual and multimedia systems
Series I	Integrated services digital network
Series J	Cable networks and transmission of television, sound programme and other multimedia signals
Series K	Protection against interference
Series L	Environment and ICTs, climate change, e-waste, energy efficiency; construction, installation and protection of cables and other elements of outside plant
Series M	Telecommunication management, including TMN and network maintenance
Series N	Maintenance: international sound programme and television transmission circuits
Series O	Specifications of measuring equipment
Series P	Telephone transmission quality, telephone installations, local line networks
Series Q	Switching and signalling, and associated measurements and tests
Series R	Telegraph transmission
Series S	Telegraph services terminal equipment
Series T	Terminals for telematic services
Series U	Telegraph switching
Series V	Data communication over the telephone network
Series X	Data networks, open system communications and security
Series Y	Global information infrastructure, Internet protocol aspects, next-generation networks, Internet of Things and smart cities
Series Z	Languages and general software aspects for telecommunication systems