

Superseded by a more recent version



INTERNATIONAL TELECOMMUNICATION UNION

ITU-T

TELECOMMUNICATION
STANDARDIZATION SECTOR
OF ITU

H.224

(11/94)

TRANSMISSION OF NON-TELEPHONE SIGNALS

**A REAL TIME CONTROL PROTOCOL
FOR SIMPLEX APPLICATIONS USING
THE H.221 LSD/HSD/MLP CHANNELS**

ITU-T Recommendation H.224

Superseded by a more recent version

(Previously "CCITT Recommendation")

Superseded by a more recent version

FOREWORD

The ITU-T (Telecommunication Standardization Sector) is a permanent organ of the International Telecommunication Union (ITU). The ITU-T is responsible for studying technical, operating and tariff questions and issuing Recommendations on them with a view to standardizing telecommunications on a worldwide basis.

The World Telecommunication Standardization Conference (WTSC), which meets every four years, establishes the topics for study by the ITU-T Study Groups which, in their turn, produce Recommendations on these topics.

The approval of Recommendations by the Members of the ITU-T is covered by the procedure laid down in WTSC Resolution No. 1 (Helsinki, March 1-12, 1993).

ITU-T Recommendation H.224 was prepared by ITU-T Study Group 15 (1993-1996) and was approved under the WTSC Resolution No. 1 procedure on the 1st of November 1994.

NOTE

In this Recommendation, the expression "Administration" is used for conciseness to indicate both a telecommunication administration and a recognized operating agency.

© ITU 1995

All rights reserved. No part of this publication may be reproduced or utilized in any form or by any means, electronic or mechanical, including photocopying and microfilm, without permission in writing from the ITU.

Superseded by a more recent version

CONTENTS

	<i>Page</i>
1 Scope	1
2 References.....	1
3 Definitions	2
4 Abbreviations.....	3
5 Conventions	3
6 Relationship to other Recommendations.....	4
6.1 Relationship to Recommendation H.221	4
6.2 Relationship to T.120 protocols	5
7 Major features.....	5
7.1 Physical layer transmission over H.221.....	5
7.2 Client Data Block segmentation	6
7.3 Terminal address resolution	7
7.4 Client ID assignments.....	7
7.5 Data layer protocol frame structure	7
8 Field descriptions.....	7
9 Client Management Entity	9
9.1 CME Client List Message	10
9.2 CME Extra Capabilities Message.....	10
9.3 CME Client List Command	10
9.4 CME Extra Capabilities Command	10
9.5 CME standard command codes	12
9.6 CME standard response codes.....	12
10 List of Standard Clients IDs.....	12
10.1 Extended Client IDs	12
10.2 Non-Standard Client IDs	12

Superseded by a more recent version

SUMMARY

This Recommendation provides a simple yet flexible protocol for simplex, low delay applications such as far end camera control using the LSD, HSD, and MLP channels defined in Recommendations H.221 and H.243.

Superseded by a more recent version

Recommendation H.224

A REAL TIME CONTROL PROTOCOL FOR SIMPLEX APPLICATIONS USING THE H.221 LSD/HSD/MLP CHANNELS

(Geneva, 1994)

1 Scope

This Recommendation covers the frame structure, elements of procedure and formats to support a real time control (Recommendation H.224) protocol primarily used in multipoint videoconference networks using the H.243 broadcast capability of the H.221 LSD/HSD channels or the H.221 MLP data channel. H.224 frames are encapsulated in Q.922 Unnumbered Information (UI) frames, referred to as I mode for the remainder of this Recommendation.

This protocol is intended to be used by Recommendations that describe applications that require the real-time H.224 services, limited at this time to far end camera control but potentially including other real-time applications. This protocol serves to provide low-cost, low-latency and low delay broadcast services for applications that do not require reliable, flow-controlled links. This Recommendation is not intended for use by applications such as those specified in the T-Series, e.g. JPEG image distribution that require reliable links.

This protocol allows for multiplexing of one or more datagram streams over the H.221 LSD, HSD or MLP channels. Data transfer is always by way of Q.922 UI frames using fixed DLCI assignment. The data link protocol contains network layer information using unique source and destination terminal addresses, conveyed to the terminal via the TIA symbol as described in Recommendations H.230 and H.243.

The block diagram in Figure 1 illustrates the location of the data link protocol in a H.221 communications architecture. The interface between the client and the data link layer is beyond the scope of this Recommendation, and is left to the discretion of the manufacturers.

2 References

The following Recommendations and other references contain provisions which, through reference in this text, constitute provisions of this Recommendation. At the time of publication, the editions indicated were valid. All Recommendations and other references are subject to revision: all users of this Recommendation are therefore encouraged to investigate the possibility of applying the most recent edition of the Recommendations and other references listed below. A list of the currently valid ITU-T Recommendations is regularly published.

- ITU-T Recommendation H.221 (1993), *Frame structure for a 64 to 1920 kbit/s channel in audiovisual teleservices.*
- ITU-T Recommendation H.243 (1993), *Procedures for establishing communication between three or more audiovisual terminals using channels up to 2 Mbit/sec.*
- CCITT Recommendation Q.922 (1992), *ISDN data link service for frame mode bearer services.*
- ISO/IEC 3309 (1991), *High-level data link control (HDLC) procedure – Frame structure.*
- ITU-T Recommendation T.125 (1994), *Multipoint communication service protocol specification.*
- ITU-T Recommendation T.122 (1993), *Multipoint communication service for audiographics and audiovisual conferencing service definition.*
- ITU-T Recommendation T.123 (1993), *Protocol stacks for audiovisual and audiographic teleconference applications.*

Superseded by a more recent version

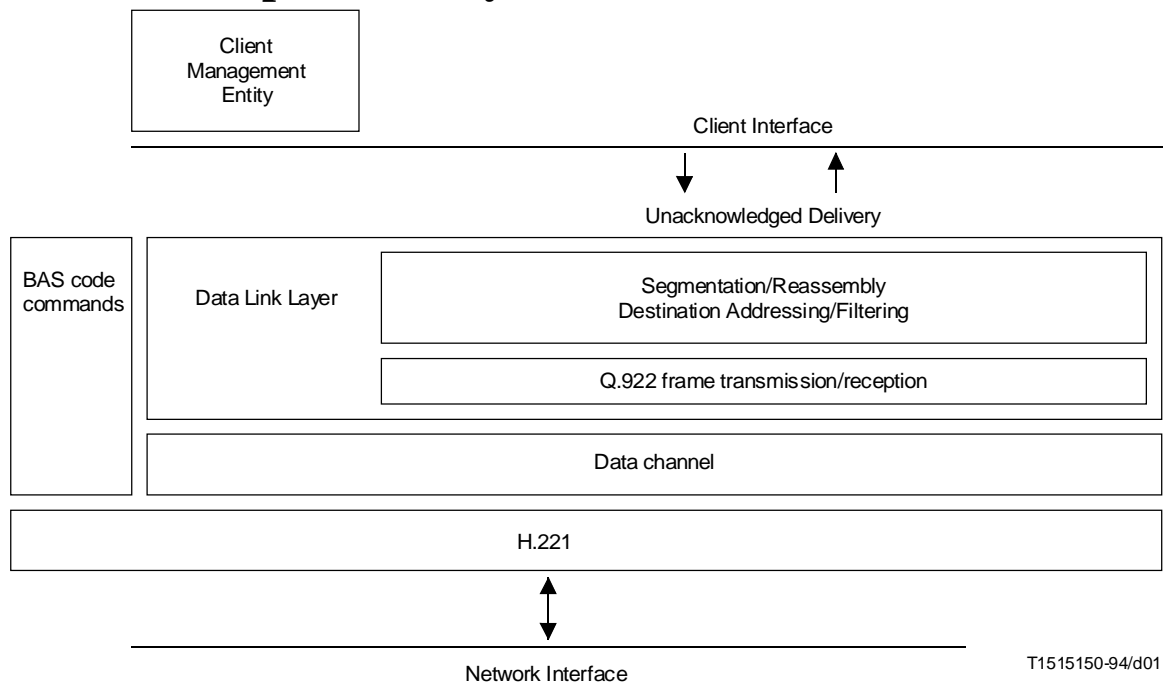

FIGURE 1/H.224

Block diagram of real time control protocol

3 Definitions

For the purposes of this Recommendation, the following definitions apply:

BROADCAST value: The Terminal address value which specifies all connected terminals in a conference. For all data channels, the BROADCAST value is 0x0000.

channel: One of the H.221 data channels, LSD (low speed data), HSD (high speed data), or MLP (multilayer protocol). Note that MLP and H-MLP are aggregated to form a single data channel as specified in Recommendation T.123.

client: An entity that uses the data transfer services of the Data Link layer. An example of a Client is Far End Camera Control.

client data block: A unit of data submitted at the H.224 Client Interface. If the H.224 segments a Client Data Block before transmission, the remote terminal must receive all segments (in numerical order) before submitting the reconstructed Client Data Block to the destination client. The maximum length of a Client Data Block is 1024 octets.

client ID: An unique identification number used when sending data to a specific client. Clients that are standardized for use in generic applications are allocated Standard Client IDs (listed in Recommendation H.224). Client IDs also may be assigned for non-standard or proprietary applications using the manufacturer specific mechanism described.

client management entity: A data link client that uses Client ID 0x00 to send a complete list of locally registered clients and their optional extra capabilities.

HDLC frame format: As specified in ISO/IEC 3309.

high priority data: Client Data Blocks that require a low transmission time latency and/or low transmission time variability.

low priority data: Client Data Blocks that are part of a large data transfer that requires maximum bandwidth efficiency to minimize the total time to complete the transfer.

Superseded by a more recent version

MLP channel: A H.221 channel in which H.224 and/or the T.120-series protocols are run.

MLP compatibility mode: An H.224 operation mode which uses the MLP channel to transfer data. H.224 data sent on the MLP channel is broadcast to all other H.224 capable terminals.

simplex protocol: A communication protocol that is purely one-way, and where acknowledgements are not part of any application protocol. Error control is either not present, or is accomplished via forward error correction.

Recommendation T.120: The overview document for the T-Series Recommendations. This is similar to the fashion in which Recommendation H.320 describes terminal equipment conforming to the H-Series Recommendations.

T.120 protocols: A suite of protocols including T.122, T.123, T.124, T.125 and others that provide multipoint, reliable data transfer and application coordination for conferencing applications.

UI-mode: A mode of operation in which the H.224 protocol is encapsulated within the information field of Q.922 UI frames for multipoint applications (see Figure 2).

4 Abbreviations

BECN	Backward Explicit Congestion Notification (Recommendation Q.922)
BS	Beginning Segment
CME	Client Management Entity
DE	Discard Eligibility Indicator (Recommendation Q.922)
DLCI	Data Link Connection Identifier (Recommendation Q.922)
EA	Address Field Extension Bit (Recommendation Q.922)
ES	Ending Segment
FCS	Frame Check Sequence
FECN	Forward Explicit Congestion Notification
HDLC	High-level Data Link Control
LSB	Least Significant Bit
MCU	Multipoint Control Unit
MSB	Most Significant Bit
UI frame	Unnumbered Information frame.

5 Conventions

- *Channel* – Refers to the LSD channel, the HSD channel, the MLP channel or the aggregated MLP/H-MLP channel.
- *BROADCAST value* – Always refers to the value 0x0000 when used in place of the terminal address to indicate a request to broadcast the packet to all conference members.
- *Equipment* – Refers to both terminals and MCUs.
- *ID* – Short for identifier.
- “*Shall*” – Used in this Recommendation to specify a mandatory requirement.
- “*Should*” – Used in this Recommendation to specify a suggested but not required course of action.

Superseded by a more recent version

6 Relationship to other Recommendations

6.1 Relationship to Recommendation H.221

6.1.1 H.224 Capabilities

- H.224-LSD – The H.224 equipment is capable of operating on the LSD channel, including turning H.224 on and off. This capability is mandatory for H.224 terminals and optional for H.224 MCUs. The H.224 operation on both LSD and the HSD channels at the same time is for further study.
- H.224-MLP – The H.224 equipment is capable of operating on the MLP channel as described in 6.2, including turning H.224 on and off. This capability is mandatory for H.224 terminals and optional for H.224 MCUs. If an MCU has this capability, it shall broadcast any UI frames it receives on the MLP channel from one terminal to all other terminals in the conference as required by H.224. The presence of this capability in a terminal does not imply the support of the T.120 protocols.
- H.224-HSD – The H.224 equipment is capable of operating on an HSD channel, including turning H.224 on and off. This capability is optional for H.224 terminals and MCUs. The H.224 operation on both the LSD and the HSD at the same time is for further study.
- H.224-sim – The H.224 equipment is capable of simultaneously operating H.224 in the LSD channel and T.120 protocols in the MLP channel. Thus, H.224-sim capability equipment can both:
 - a) open allowed combinations of LSD and MLP channels; and
 - b) simultaneously run H.224 in LSD and T.120 protocols in MLP.

This capability is optional for H.224 equipment.

6.1.2 H.224 Commands

H.224 procedures apply to these commands:

- H.224-LSD-on – Used to indicate the start of H.224 operation on the open LSD channel. This command shall be ignored if the LSD channel is not open. Operations if H.224 is already running on the HSD channel are for further study.
- H.224-LSD-off – Used to indicate the cessation of H.224 operation on the open LSD channel. This command shall be ignored if the LSD channel is not open.
- H.224-HSD-on – Used to indicate the start of H.224 operation on the open HSD channel. This command shall be ignored if the HSD channel is not open. Operations if H.224 is already running on the LSD channel are for further study.
- H.224-HSD-off – Used to indicate the cessation of H.224 operation on the open HSD channel. This command shall be ignored if the HSD channel is not open.
- H.224-MLP-on – Used to indicate the start of H.224 operation on the open MLP channel. This command shall be ignored if the MLP channel is not open.
- H.224-MLP-off – Used to indicate the cessation of H.224 operation on the open MLP channel. This command shall be ignored if the MLP channel is not open.

6.1.3 Operations

H.224 terminals shall declare the H.221 capability of LSD channel operation at 6400 bits/s in addition to any other LSD or HSD rates that they may support. Terminals with the capability for encryption shall also declare the capability of LSD operation at 4800 bits/s. H.224 terminals shall declare the H.221 capability for MLP data channel operation at 6400 bits/s in addition to any other MLP rates that they may support.

H.224 terminals shall declare the H.224-MLP capability as described in 6.2. H.224 terminals shall declare the H.224-LSD capability. H.224 equipment may optionally declare the capability of H.224-sim. H.224 equipment may optionally declare the H.224-HSD capability. H.224 capabilities and commands are defined in 6.1.1 above, and the code points are found in Recommendation H.221.

Superseded by a more recent version

H.224 MCUs shall declare at least one of:

- a) H.224-LSD/LSD-6400; or
- b) H.224-MLP/MLP-6400.

If the MCU supports encryption, LSD 4800 capability shall also be declared.

6.2 Relationship to T.120 protocols

The H.224 equipment shall support operation in the MLP channel in the compatibility mode described below. If the H.224 equipment is running T.120 protocols in the MLP channel and it is desired that only a single channel (MLP) be opened in the conference, both H.224 and T.120 protocols may share the same MLP channel. H.224 shall not be used on the LSD channel at the same time as H.224 is used on the MLP channel.

When the T.120 protocol is operating in the MLP channel and it is desired that only a single channel be used, all H.224 datagrams shall be transferred in the MLP data channel interspersed with T.120 packets. When operating in this mode, an MCU recognizes the UI frame value of the Q.922 Control Octet as an indication that the packet is an H.224 packet. This is possible since MLP does not make use of UI frames. For multipoint operation, the MCU broadcasts the data packets without examining them further. Implementers should note that unlike in the case of operation over the LSD or HSD channel, there may be more than one broadcaster since there is no token system that applies to the MLP channel. For applications such as far end camera control using H.224 in the MLP channel, it may be desirable to take corrective action in the terminal to avoid rapid back and forth camera motion as two parties attempt to control the same camera.

An exception to the above mode of operation occurs if the terminals and MCUs involved have indicated the H.224-sim capability of simultaneous T.120 protocol operation and H.224 operation in separate channels. In this case the H.224 protocol may be used in the LSD channel at the same time as the T.120 protocols are being used in the MLP channel. The MCU should only use this mode of operation if all terminals in a conference support H.224-sim capability.

7 Major features

The major features of the H.224 protocol are:

- encapsulation of a data link protocol within Q.922 frames (UI type) using reserved DLCI addresses;
- inclusion of H.243 MCU/terminal identifiers or MCS User Ids in each H.224 header;
- a Client Management Entity (CME) that sends a complete list of registered data clients and any extra capabilities supported by each client;
- a BROADCAST value of the terminal identifier that allows the entire conference to be addressed.

7.1 Physical layer transmission over H.221

The H.224 protocol shall be sent as the information fields of Q.922 frames which are specified in Recommendation Q.922. Data is sent in the H.221 LSD or HSD channels, or only in the MLP data channel. Operation with both H.221 LSD and HSD channels open at the same time is left for further study.

As defined in Recommendation Q.922 (see 2.2/Q.922), all frames start and end with the flag sequence, and the closing flag of one frame may also serve as the opening flag of the next frame.

The maximum length of a Client Data block is 1024 octets¹⁾.

¹⁾ At low data rates (e.g. under 14 400 bit/s), the size of the client data block may be limited to a value less than 1024 octets by the fact that no more than 16 segments are allowed, and the number of user bytes in each segment is less at lower data rates to meet the latency requirement for high priority data. Application developers should take note of this fact.

Superseded by a more recent version

7.2 Client Data Block segmentation

Segmentation is the process of dividing large client blocks into a series of smaller contiguous segments with each segment numbered and sent individually. Lost segments at the H.224 level are not retransmitted. Client Data Blocks for a given client may be sent on either channel, provided that all the segments of any single Client Data Block are sent on the same channel. The Recommendation for a particular H.224 client may specify that data for that client be sent on a specific channel to ensure that all Client Data Blocks are received in the order they were transmitted.

Segmentation is used for three purposes:

- to guarantee that the size of the information field in the Q.922 frames does not exceed the Q.922 default maximum of 260 octets;
- to limit transmission time latency when sending high priority data, where latency is the time from submission of a Client Data Block to commencement of transmission;
- to limit variation in transmission latency when sending high priority data.

7.2.1 Maximum information field size

No Client Data Block segment shall have an information field longer than the Q.922 maximum of 260 octets.

7.2.2 Maximum transmission time

Data block priority is indicated via the use of fixed DLCIs. A given client may send both high and low priority data blocks.

The maximum segment size for all high priority Client Data Blocks shall be the size corresponding to 60 milliseconds of transmission time on the transmitting channel (including header, framing, and zero insertion overhead). No low priority Client Data Block segments shall be transmitted on a given channel when any high priority Client Data Blocks are pending transmission on that channel. Instead, all high priority segments shall be sent before the next low priority segment.

If there are multiple high priority Client Data Blocks pending transmission on a channel, the H.224 transmitter shall interleave segments from each pending high priority Client Data Block in a round robin manner.

If there are no high priority Client Data Blocks pending transmission on a channel, and a high priority Client Data Block was sent on the channel within the previous one second, the maximum transmitter latency for high priority Client Data Blocks on that channel shall be 60 milliseconds.

If there are no high priority Client Data Blocks pending transmission on a channel, and a high priority Client Data Block was not sent on the channel within the previous one second, the maximum transmitter latency for high priority Client Data Blocks on that channel shall be 250 milliseconds.

The above latency values apply only for high priority Client Data Blocks transmitted at a channel data rate of 4800 bits/s or higher.

7.2.3 Segment numbering

The H.224 segment number octet shall contain a modulo 16 number that is maintained independently for each Client Data Block. The segment that is the beginning of a new Client Data Block shall have the Beginning Segment (BS) bit set. The initial segment number for each Client Data Block is arbitrary, and is determined by the transmitter. The segment that is the end of a Client Data Block shall have the Ending Segment (ES) bit set. A H.224 receiver shall not forward a reconstructed Client Data Block unless:

- i) all the segments from the last Beginning Segment are received in order (accounting for modulo 16 roll over); and
- ii) the Ending Segment has been received. Anything else constitutes an error and all accumulated segments shall be discarded. A client data block shall be broken into no more than 16 segments.

See clause 8, "Field Descriptions", for information on the segmentation octet.

Superseded by a more recent version

7.3 Terminal address resolution

The H.224 frame's Q.922 DLCI and Q.922 control octet values are shown in Figure 2. These values identify that:

- The “information” field in the Q.922 frame is formatted to the data link protocol defined in this Recommendation.
- The terminal addresses in this data link protocol header provides unique identification of each terminal in a videoconference.
- The source and destination terminal addresses shall be those assigned to the terminal via the TIA symbol described in Recommendation H.243. A terminal address is only valid for the duration of a specific videoconference. Note that when the T.120 protocols are running simultaneously with H.224, the internal structure of the TIA address may be different from that in H.243. Thus, terminal designers should not rely on the internal <M> <T> structure in this mode of operation.

7.4 Client ID assignments

Standard Clients are assigned single octet IDs starting with the hexadecimal value 0x01. New ID assignments will be made to the standard list as they are identified and Recommendations become available. In addition to Standard Client ID assignment the protocol supports Extended IDs to handle the case when no more Standard Client IDs are available. Assignment of a Non-standard Client ID is possible for proprietary clients using a format identical to the H.221 country/manufacturer format for non-standard capabilities.

Client ID 0x00 is reserved for the Client Management Entity (CME) which provides the following remote services:

- Client List Message – Lists all the registered clients. The scenarios under which this message can be sent are listed in a later clause of this Recommendation.
- Extra Capabilities Message – Contains the extra capabilities of the client specified.

7.5 Data layer protocol frame structure

The Data Layer protocol shall be sent as the information field within a Q.922 frame with HDLC flags used as the frame delimiters. Data is sent out LSB first. HDLC flags shall be used as fill. Figure 2 depicts the structure of the entire frame.

8 Field descriptions

Flag

This field is used to identify start of frame.

Q.922 Address Header

The 10-bit DLCI address shall be set to 0000000110 (upper DLCI 0x00, lower DLCI 0x06) for low priority data and shall be set to 0000000111 (upper DLCI 0x00, lower DLCI 0x07) for high priority data.

FECN, BECN and DE bits shall be set to 0. Received BECN and FECN bits shall be ignored by this Data Link Layer.

C/R bit is set to 0 in UI mode frames.

Q.922 Control Octet(s)

UI-Mode format: One control octet shall be sent, and is set to 0x03 for H.224 UI mode frames.

Superseded by a more recent version

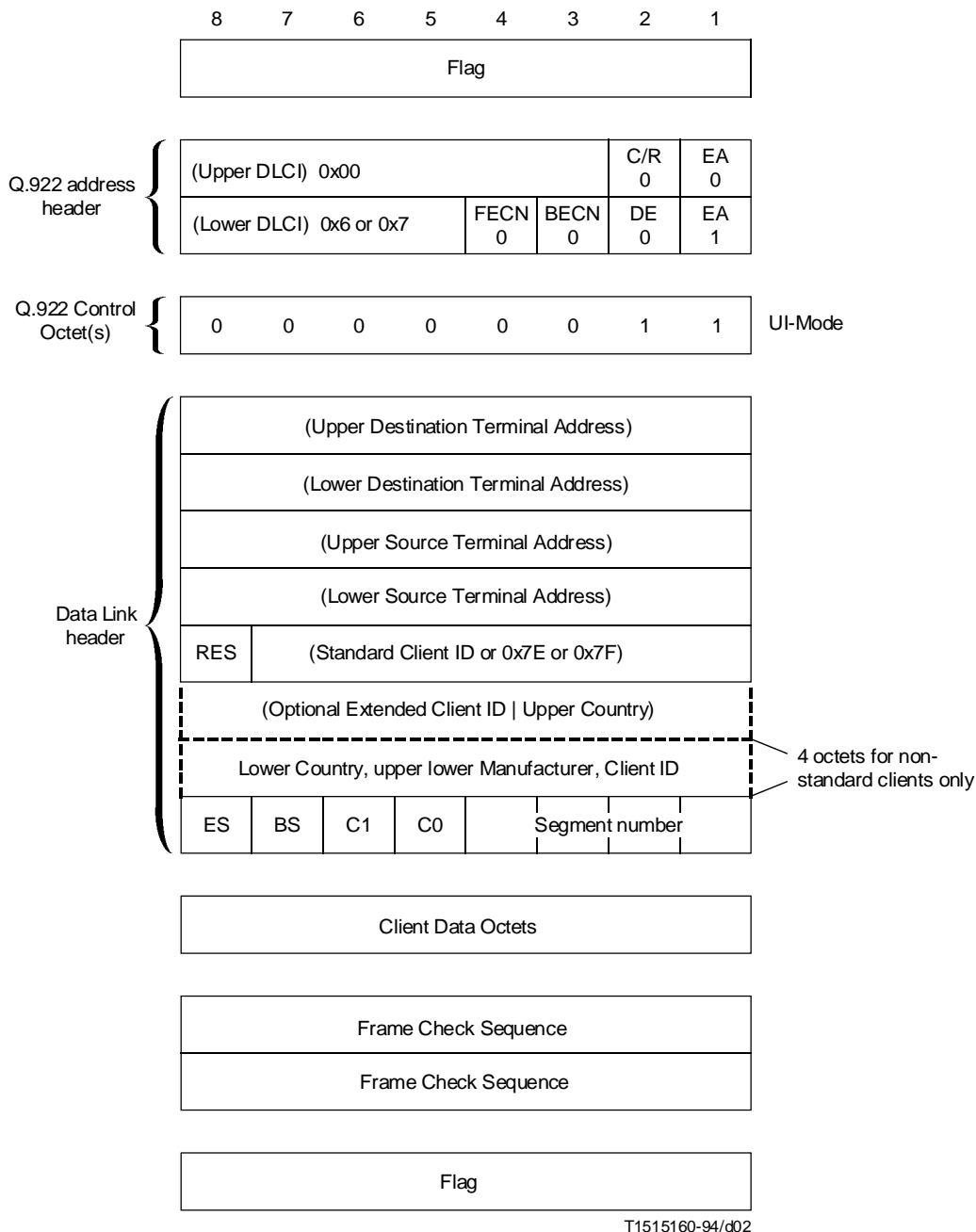

T1515160-94/d02

FIGURE 2/H.224
H.224 protocol octet structure

Data Link Header

- DESTINATION Terminal address – Associates the Data Link datagram with a specific destination terminal or otherwise the BROADCAST value is used when all terminals in a multipoint conference are being addressed. The terminal address shall be that assigned to the destination terminal by the MCU using the TIA symbol. If no MCU is present then the BROADCAST value shall be used.
- SOURCE Terminal Address – Associates the Data Link datagram with a specific source terminal address. The terminal address shall be the value provided most recently by the TIA symbol described in Recommendation H.243. If no MCU is present then the BROADCAST value shall be used.

Superseded by a more recent version

- CLIENT ID – The client to receive the contents of the datagram. The Client ID may be any of the following formats:
 - Standard Client ID – Single octet.
 - Extended Client ID – Two octets (0x7E, extended Client ID).
 - Non-standard Client ID – Six octets (0x7F, country, manufacturer code, ID).
- RES – This field is reserved for further study. This bit shall be set to 0 by transmitter and shall be ignored by a receiver.
- SEGMENTATION OCTET – The segment number is a modulo-16 count maintained independently for each Client Data Block. The BS bit shall be set to 1 to indicate the beginning segment of a new Client Data Block and the ES bit shall be set to 1 to indicate the ending segment of a Client Data Block. Both the BS and ES bits shall be set to 1 when segmentation has not occurred on the original Client Data Block. The C0 and C1 bits are control bits that may be sent on behalf of certain client peer to peer protocols. On transmission, the current state of these control bits shall be placed in each outgoing datagram. On reception, the most recently received state of these bits shall be maintained or passed to the client.

Client Data Octets

Variable length client data sent as an integral number of octets.

Frame Check Sequence

The FCS is the checksum specified in Recommendation Q.922.

Flag

This field is used to identify end of frame.

9 Client Management Entity

The Client Management Entity (CME) sends information about its locally registered clients, and receives information about far-end registered clients, over Standard Client ID 0x00. Information about the clients is sent (or re-sent) whenever the CME has reason to conclude that some far-end entity may not already have the information, and whenever the contents of the information change.

The Client Management Entity (CME) sends information about its registered clients over Standard Client ID 0x00, under the following conditions:

- on detection of a new video terminal in an existing conference (i.e. receipt of the TIN BAS code – see Recommendation H.243);
- explicit inquiry over Standard Client ID 0x00 in the form of a CME Client List Command or CME Extra Capabilities Command;
- when one or more local clients newly registers or deregisters or when the terminal has just joined a conference;
- if a datagram is received for an unknown client AND the destination Terminal address is not the BROADCAST value;
- at other times, unsolicited.

The CME information sent is a list of all registered clients (CME Client List Message, a single datagram) followed by a sequence of datagrams, each containing specific capabilities of an individual client (CME Extra Capabilities Message).

All CME Client Data Blocks shall be transmitted as Low Priority Data. For all CME Client Data Blocks, the destination Terminal address shall be set to the BROADCAST value.

If both the LSD and HSD channels are in use for H.224, all CME client data blocks are transmitted on the LSD Channel only.

The CME manages clients for all Channels, aggregated together.

Unrecognized CME messages shall be ignored by the receiver.

Superseded by a more recent version

9.1 CME Client List Message

After a remote entity has requested the client list by sending a Client List Command message, the addressed CME then responds with the CME Client List message shown in Figure 3. Refer to the list above for reasons why the CME Client List message would be sent.

This datagram contains a list of registered clients. The CME client itself shall not be included in the list.

The EX CAPS bit shall be set when indicating that CME Extra Capabilities exist and are associated with the client.

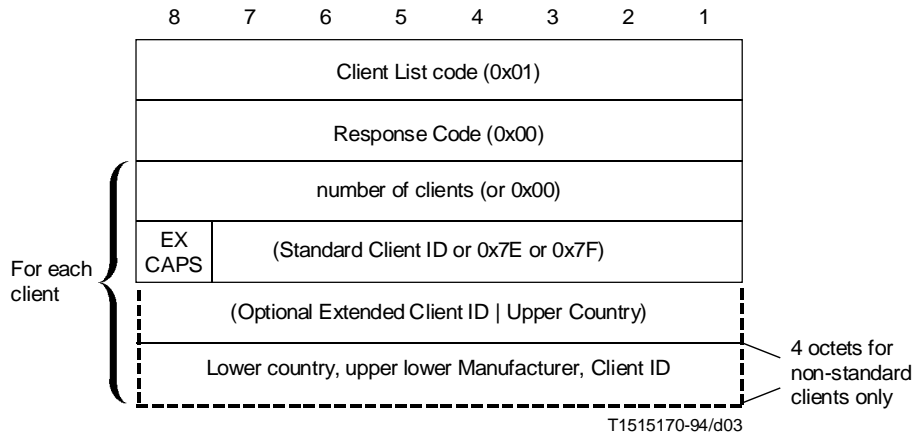

FIGURE 3/H.224
CME Client List Message

9.2 CME Extra Capabilities Message

Each client, at time of registration, can elect to have block of specific capabilities sent on it's behalf by the CME. A CME Extra Capabilities message contains the extra capabilities of one client. The CME sends CME Extra Capabilities messages for each client which has so elected, after sending the CME Client List message.

The contents of the CME Extra Capabilities message for each client may change in succeeding transmissions, reflecting changing status of the client.

The CME Extra Capabilities Message is shown in Figure 4.

9.3 CME Client List Command

The CME may request retransmission of the CME Client List Message by sending a CME Client List Command datagram, shown in Figure 5.

The addressed CME shall respond to this command by sending its CME Client List Message. In this case the CME is not required to follow the CME Client List Message with the sequence of CME Extra Capabilities Message datagrams, although it may chose to do so.

9.4 CME Extra Capabilities Command

The CME may request retransmission of a specific client's CME Extra Capabilities Message by sending a CME Extra Capabilities Command datagram, shown in Figure 6.

The addressed CME shall respond to this command by sending the CME Extra Capabilities Message datagram for the referenced client.

Superseded by a more recent version

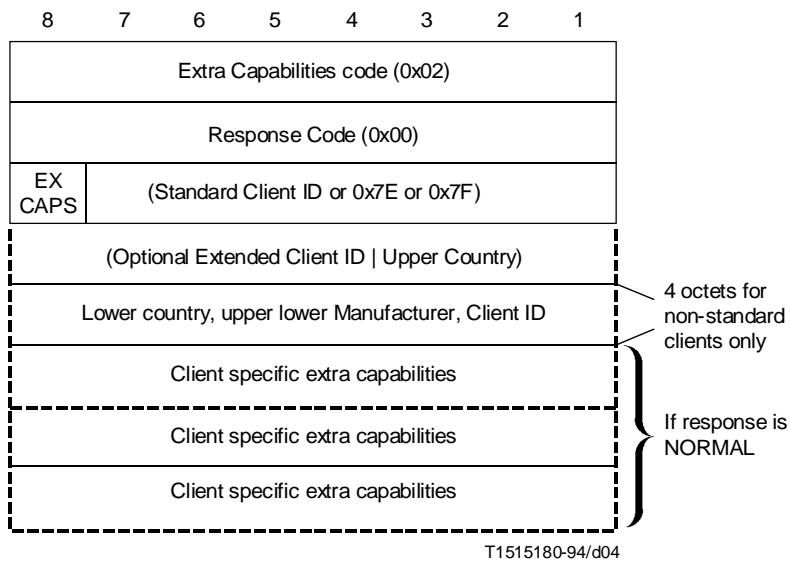

FIGURE 4/H.224
CME Extra Capabilities Message

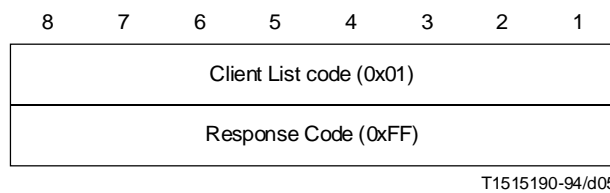

FIGURE 5/H.224
CME Client List Command

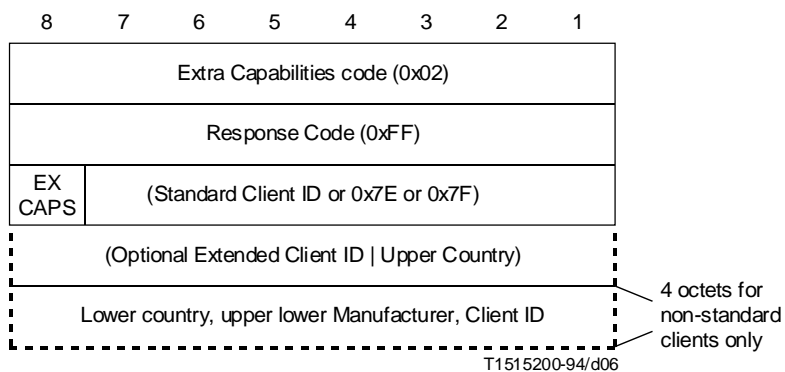

FIGURE 6/H.224
CME Extra Capabilities Command

Superseded by a more recent version

9.5 CME standard command codes

0x00	Null, does nothing
0x01	CME client list code
0x02	CME extra capabilities code

9.6 CME standard response codes

0x00	Message
0xFF	Command

10 List of Standard Clients IDs

Table 1 is a list of Standard Clients IDs that are currently identified. This table may be extended beyond 125 values by using Extended IDs as explained in the following subclause.

The Standard Client IDs will be assigned, in numerical order, as new clients are identified and Recommendations are made available.

TABLE 1/H.224
Standard Client IDs

Client Name	Standard Client ID	Reference Recommendation
CME	0x00	H.224
Far End Camera Control	0x01	H.281
Reserved	0x02 through 0x7D ^{a)}	
Extended Client ID list	0x7E	H.224
Non-standard client	0x7F	H.224

^{a)} Codes 0x02 through 0x7D are reserved for possible future applications, which are a matter for further study.

10.1 Extended Client IDs

The table of Standard Client IDs may be extended to another 127 value table by using the Standard Client ID escape code 0x7e indicating that the list of standard IDs has been extended to another table and the octet following is the ID of the client referenced by the Extended ID client table.

Extended IDs are intended for use only if the list of standard IDs (0x01-0x7D) is exhausted.

10.2 Non-Standard Client IDs

The Standard Client IDs escape code 0x07F indicates that a five octet country, manufacturer, client code follows. Non-standard ID's are intended for use only if the manufacturer does not wish to register for a standard or extended client ID assignment.

Non-standard Client IDs shall include country and manufacturer codes exactly as Recommendation H.221.

- (octet 1) Upper Country code octet according to Recommendation T.35
- (octet 2) Lower Country code octet
- (octets 3 and 4) Upper and Lower Manufacturer code octets (country specific)
- (octet 5) Manufacturer Client ID