



INTERNATIONAL TELECOMMUNICATION UNION

CCITT

THE INTERNATIONAL
TELEGRAPH AND TELEPHONE
CONSULTATIVE COMMITTEE

I.310

(11/1988)

SERIES I: INTEGRATED SERVICES DIGITAL
NETWORK (ISDN)

Overall network aspects and functions, ISDN user-
network interfaces

**ISDN – NETWORK FUNCTIONAL
PRINCIPLES**

Reedition of CCITT Recommendation I.310 published in
the Blue Book, Fascicle III.8 (1988)

NOTES

1 CCITT Recommendation I.310 was published in Fascicle III.9 of the *Blue Book*. This file is an extract from the *Blue Book*. While the presentation and layout of the text might be slightly different from the *Blue Book* version, the contents of the file are identical to the *Blue Book* version and copyright conditions remain unchanged (see below).

2 In this Recommendation, the expression “Administration” is used for conciseness to indicate both a telecommunication administration and a recognized operating agency.

Recommendation I.310

ISDN – NETWORK FUNCIONAL PRINCIPLES

(Malaga-Torremolinos, 1984; amended at Melbourne, 1988)

1 General

1.1 *Basic philosophy of the functional description*

The objective of this Recommendation is to provide a common understanding of the ISDN capabilities, including terminal, network and specialized service centre aspects.

A functional description of ISDN capabilities must allow a clear distinction between definition/specification aspects of services provided by the ISDN and the actual specification of the equipment utilized to support those services. Therefore, an implementation-independent approach should be adopted.

Moreover in the context of this Recommendation the adjective “functional” is used in the sense of an implementation-independent approach. The noun “function” itself has a specific meaning which is explained below.

The description of network capabilities is consistent with the protocol reference mode, e.g.:

- the layering structure of all systems involved in a communication process, i.e. partitioning the required functions between different layers;
- the clear discrimination between layer service concept, layer function concept and layer protocol concept.

Furthermore, the three following distinctions apply:

- distinction between basic services and supplementary services;
- distinction between ISDN capabilities and services offered to the customer;
- distinction between static and dynamic aspects of the description.

1.2 *Services supported by an ISDN*

The concepts and the principles of an ISDN are described in Recommendation I.120. The services supported by an ISDN are given in the I.200-Series of Recommendations. A classification and the tools for the description of telecommunication services are specified in Recommendation I.210 according to the description method as given in Recommendation I.130. The network capabilities to support these services are defined in the I.300-Series of Recommendations. The relationship between these Recommendations and some other relevant I-Series Recommendations is shown in Figure 1/I.310.

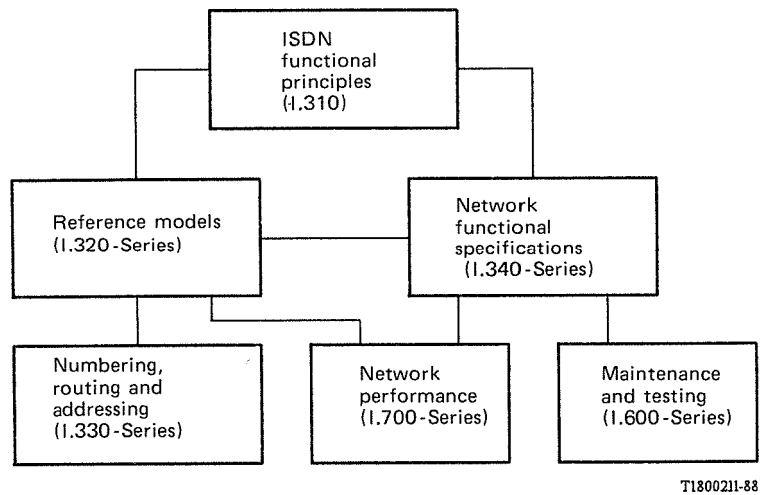

FIGURE 1/I.310

ISDN network series of Recommendations

It should be noted that the service concept defined in Recommendation I.210 is different from the layer service concept of the OSI model. The telecommunication service concept in Recommendation I.210 corresponds to the services offered to users by the network. Besides operational and commercial aspects, the provision of these telecommunication services (bearer and teleservices) and associated supplementary services requires the availability of appropriate capabilities:

- network capabilities, in various network equipments (exchanges etc.);
- terminal capabilities;
- specialized service centre capabilities, when required.

1.3 *Generic description of required capabilities*

ISDN capabilities are the total sum of the functions required to support all basic and supplementary services offered by the ISDN.

1.3.1 *Static description*

The identification and characterization of these functions, which are related to the specification and analysis of these basic and supplementary services, form the first step of the generic description. This part of the generic description is intrinsically static.

1.3.2 *Dynamic description*

The use of a basic or supplementary service generally requires cooperation between functions located in different equipment.

The static description of the ISDN capabilities, which will be a list of functions, is not sufficient. It is necessary, in addition, to depict the sequence of events and the activation of functions coordinated by suitable inter-equipment signals. This second step is the dynamic aspect of the description. This involves firstly an identification and characterization of the functions and then a method of showing the dynamic interaction between functions.

2 Objectives of the functional description of the ISDN

As described in Recommendation I.120, an Integrated Services Digital Network (ISDN) is a network providing end-to-end digital connectivity to support a wide range of telecommunication services.

The characterization of ISDN is centered on three main areas:

- a) the standardization of services offered to users, so as to enable services to be internationally compatible;
- b) the standardization of user-network interfaces, so as to enable terminal equipment to be portable [and to assist in a)];
- c) the standardization of ISDN capabilities to the degree necessary to allow user-network and network-network interworking, and thus achieve a) and b) above.

The I.200-Series of Recommendations identifies the range of telecommunication services to be offered in an ISDN, namely bearer services, teleservices, and associated supplementary services and the attributes characterizing those services. The I.400-Series of Recommendations describes both the functional and technical aspects of user-network interfaces. This Recommendation defines the ISDN capabilities to support services via interfaces in terms of functions. A functional description enables a decoupling of services and ISDN capabilities, and therefore allows an implementation-independent approach.

The principal objectives of the ISDN functional method are:

- 1) to define the ISDN capabilities, by building up a harmonized set of functions that are necessary and sufficient to support telecommunication services by their static and dynamic description;
- 2) to aid the evolution of ISDN capabilities (modifications, addition of capabilities to support new basic or supplementary services), by organizing this set of functions in an open-ended and modular structure;
- 3) to aid the standardization of system-independent switching functions between exchanges of differing designs and manufacture;
- 4) to aid the standardization of interworking standards between switching systems located in different countries;
- 5) to provide information for the preparation of functional specifications for new telecommunication services;
- 6) to maximize the exploitation of functions provided and available in switching systems.

The transition from an existing network to a comprehensive ISDN may require a period of time extending over one or more decades. Therefore the design of an ISDN will be revolutionary, adding capabilities in a flexible and modular manner. An ISDN may therefore be expected to provide an open-ended set of functional capabilities able to accommodate new needs as they arise at acceptable cost.

During a long intermediate period, some functions may not be implemented within a given ISDN. Also, specific arrangements should be used to ensure compatibility with existing networks and services. An ISDN should also give access to existing services and interwork with existing networks and terminals.

3 Generic description model

3.1 *General concepts*

The ISDN functional description defines a set of capabilities which enable bearer and teleservices to be offered to users (see Recommendation I.210). The services require two different levels of ISDN capabilities viz.:

- the low-layer functions (LLF) relate to the bearer services;
- the high-layer functions (HLF) together with the lower layer functions relate to the teleservices.

In addition, operation and maintenance capabilities are required to support both bearer and teleservices (see Figure 2/I.310).

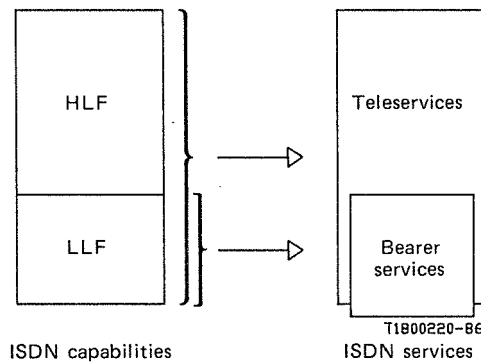

FIGURE 2/I.310

Relation between telecommunication services and network capabilities

The capabilities of the ISDN need a detailed and rigorous characterization because there is a wide range of standardization issues involved.

To achieve the functional objectives described in § 2, the ISDN functional description has been designed to:

- define the overall functional characteristics of the ISDN;
- be implementation-independent and place no constraints on national network architectures beyond the network and interface standards given in the I-Series of Recommendations;
- take full account of the constraints of existing dedicated networks;
- support the layering protocol concepts defined in Recommendation I.320.

For this purpose the concept of an ISDN function is used, which is defined as:

“A distinguishing characteristic which describes functional capabilities of a given equipment, or system, or network, as seen from the designer point of view.”

As far as possible, the number of functions should be limited.

3.2 *Static description model*

3.2.1 *Global functions (GF)*

The description of ISDN capabilities concerns the low layers (1-3) in a global context (see Note), i.e. taking into account all the equipment involved in the communication, according to the protocol reference model. In this context, a global function is defined as:

- referring to the ISDN capabilities;
- having a global significance in the lower layers.

The set of all GFs leads to the description of the total ISDN low layer capabilities.

Note – This concept of global function may be extended to describe the higher layer capabilities of ISDN terminals (and network capabilities, where these exist). In this case the GF has a global significance inside the higher layers.

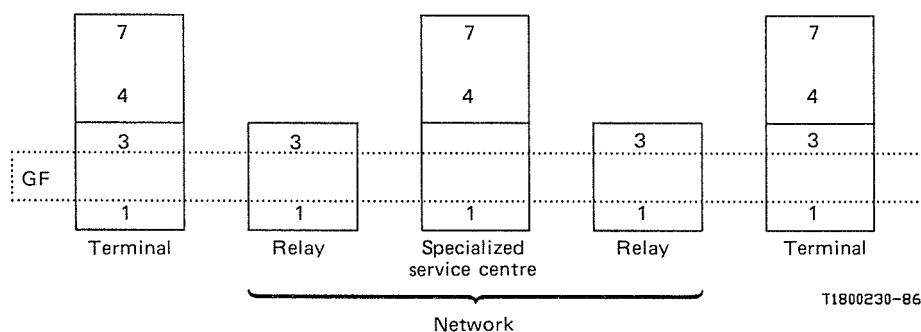

FIGURE 3/I.310

Global function concept

There are two kinds of GFs:

- the Basic Global Functions (BGF), are those global functions needed to support ISDN basic services. The BGFs are related to ISDN connection types, as indicated in Table 1/I.310;
- the Additional Global Functions (AGF), are related to the ISDN capability to support supplementary services. Details of the relationship between AGFs and the ISDN capability to support supplementary services are given in § 4.1.2.

3.2.2 *Elementary functions (EF)*

The introduction of the GF concept allows a general description of low layer capabilities.

The following is a more detailed description: for each GF, a set of elementary functions is identified as the set of basic elements which are then *allocated* to different functional entities involved in the communication.

$$GF = (EF1, EF2, EF3, \dots EF_n)$$

An EF within this Recommendation is the lowest level of functionality. It is allocated to a functional entity involved in supporting a telecommunication service. An EF is an intrinsically static description of the capability of performing an action on a resource when defined conditions are met.

For building up a GF, each associated EF must be present in one or more functional entities of the ISDN. (In this context the ISDN may include the terminals, the network or specialized service centres.) But in a specific functional entity the complete set of associated EFs need not be present (see for example Figure 4/I.310).

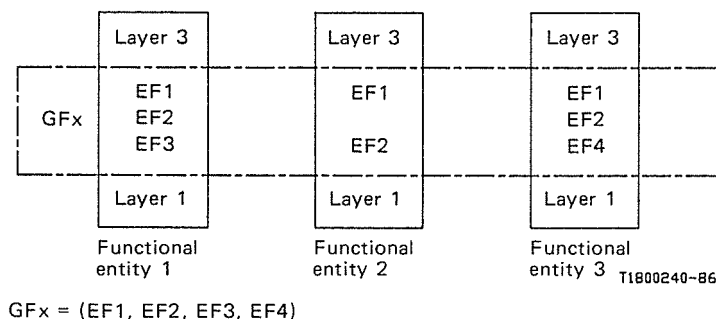

$$GF_x = (EF1, EF2, EF3, EF4)$$

FIGURE 4/I.310

FEs associated with a GFx

3.2.3 *Allocation of EFs*

This flexibility in construction of EFs allows a specialization of the functions to be allocated to particular functional entities. Because the Recommendations on the architecture of the ISDN (Recommendation I.324) will only specify a functional approach to standardization, the relationship between functional entities and specific equipment is, in general, a national matter. However an important first step in allocation of functions will be the distinction between terminal equipment and the network equipment involved.

Recommendation I.324 introduces the functional grouping CRF (connection related functions). The CRF can be local, national transit or international transit. EFs can be associated with each of these.

3.3 *Dynamic description model*

The complete description of ISDN capabilities must include dynamic aspects involved in the process of a call.

This association of functional and protocol aspects leads to the use of the following dynamic description method:

3.3.1 *Information flow diagrams*

The operation of basic and supplementary services are described and characterized, as seen from a network point of view, by using information flow diagrams which show the sequence of events occurring in the course of the call.

3.3.2 *Executive processes*

An executive process (EP) corresponds to the particular use of one or more elementary functions within a particular functional entity which always yields specific results. Therefore an EP is characterized by input information it needs for execution and by output information or actions resulting from execution.

Executive processes involve (see Figure 5/I.310):

- a) sequences that link together events producing the activation of an EP, by means of signalling information passed between the function entities;
- b) the information (or data) actually used:
 - protocol information (signalling information sent or received by the component);
 - component information (“network information”);
 - static information (description of available resources, environment, services, etc.);
 - dynamic information (elaborated and used during the call handling).

The dynamic description of each basic or supplementary service as required in stage 2 of the description method given in Recommendation I.130, based on the above elements, results in a chart showing functional entities involved (e.g. associated with originating and destination exchanges, specialized service centres when required), the signalling information flow passed between them, and the executive processes used inside them.

4 Use of generic description model

The analysis of telecommunication services and technological development leads to the identification of the range of required functions.

The analysis of all the basic and supplementary services provided by the ISDN will lead to the establishment of a set of elementary functions which can be allocated to different functional entities.

The design of a new basic or supplementary service should maximize the use of the set of existing EFs available to existing systems. This will minimize changes to the systems necessary for introducing these new services. The specifications for new equipment designed for providing particular services will have to comply with the set of EFs required for these services.

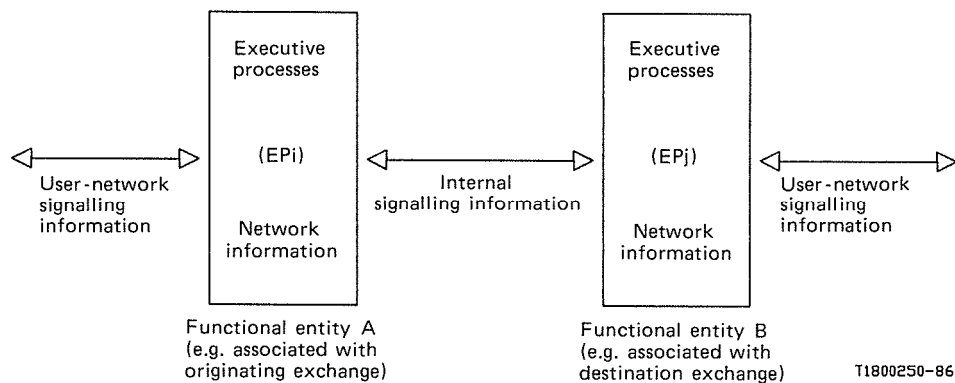

FIGURE 5/I.310

Basic functional allocation and executive processes

4.1 *Identification of ISDN global functions*

4.1.1 *Basic global functions (BGF)*

The basic global functions correspond to the ISDN capability to provide the various connection types that support telecommunication services.

The functions implemented to support telecommunication services can be classified into the following categories:

- *Connection handling*: functions which enable the establishment (set-up), holding and release of connections (e.g. user-to-network signalling).
- *Routing*: functions that determine a suitable connection for a particular service (call) request, i.e. suitable paths between the various equipments and inside the switching systems to establish end-to-end connections (e.g. called number analysis).
- *Resources handling*: functions that enable the control of the resources necessary for the use of connections (e.g. transmission equipment, switching resources, data storage equipment).
- *Supervision*: functions that check the resources used to support the connections, to detect and signal possible problems and to solve them if possible (e.g. transmission error detection and correction).
- *Operation and maintenance*: functions providing the capability to control the correct working of the services/network as well for the subscribers as for the Administration.
- *Charging*: functions providing the capability to the Administration to charge the subscribers.
- *Interworking*: functions providing the capability for both service and network interworking.
- *Layer 2 and 3 data unit handling*: functions providing handling of layers 2 and 3 data units during the information transfer phase for the case of packet mode connections.

According to this classification, a basic global function is defined as:

- referring to an ISDN connection type;
- belonging to one of the above categories.

Table 1/I.310 shows the total set of BGFs.

TABLE 1/I.310

ISDN basic global functions

Category \ Connection type	CT ₁	CT ₂	...	CT _n
Connection handling	1 BGF ₁	2 BGF ₁		n BGF ₁
Routing	1 BGF ₂	2 BGF ₂		n BGF ₂
Resources handling	1 BGF ₃	2 BGF ₃		n BGF ₃
Supervision	1 BGF ₄	2 BGF ₄		n BGF ₄
Operation and maintenance	1 BGF ₅	2 BGF ₅		n BGF ₅
Charging	1 BGF ₆	2 BGF ₆		n BGF ₆
Interworking	1 BGF ₇	2 BGF ₇		n BGF ₇
Layer 2 and 3 data unit handling	1 BGF ₈	2 BGF ₈		n BGF ₈

4.1.2 *Additional global functions (AGF)*

The additional global functions corresponds to the ISDN capability to support supplementary services.

The classification of AGFs is based on the principle that the support of a supplementary service is considered as being realized by a number of functions distributed throughout the ISDN. The definition of AGFs needs further study.

4.2 *Identification of ISDN elementary functions*

Like GFs, there are two kinds of elementary functions: the basic EFs (i.e. components of BGFs, and possibly AGFs) and the additional EFs (i.e. components of AGFs). Therefore, identification of basic EFs requires a detailed analysis of connection types. Implementation and identification of additional EFs requires a detailed analysis of supplementary services implementation.

- *Basic EFs*: for each connection type, there are up to 8 BGFs to implement (see Table 1/I.310). Therefore each BGF is composed of basic EFs related to this connection type. However some basic EFs may be common to several connection types (e.g. “called number analysis” belonging to the BGF “routing”).
- *Additional EFs*: additional EFs form a common set of functional elements available to build up the various AGFs, and thus to implement supplementary services.

This grouping of EFs into sets of BGFs and AGFs is illustrated in Figure 6/I.310.

The list of EFs so far identified is contained in Annex A, together with a preliminary set of definitions.

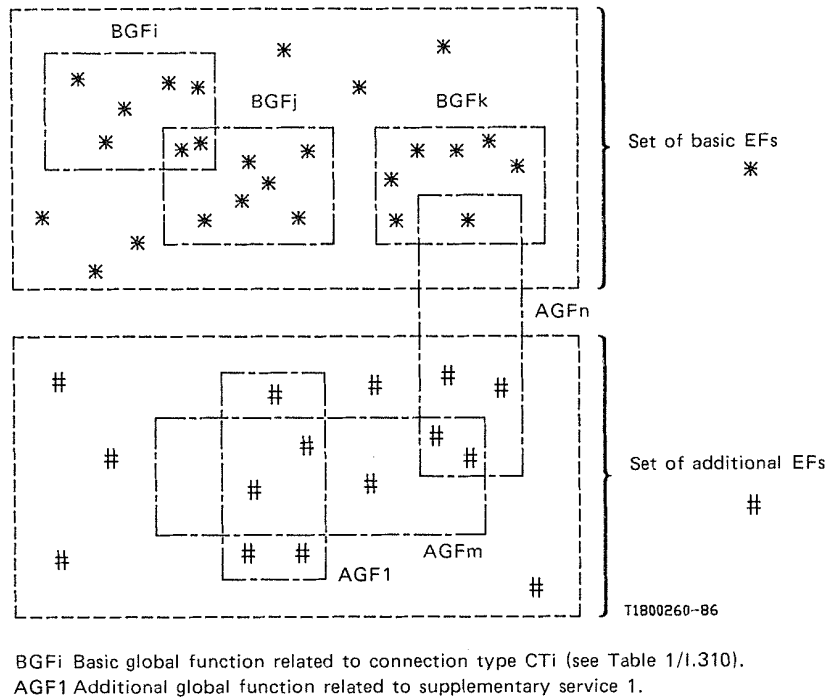

FIGURE 6/I.310

EFs association principles for building up GFs

4.3 *Identification of ISDN executive processes*

A possible use of the concept of an Executive Process (EP) is the definition of Functional Components (FC) as executive processes that can be invoked by the network to realize a telecommunication service.

According to this an FC is a specific example of how to use the EP concept.

A functional component is a set of elementary functions performed in an order that yields a specified result. An FC always has an invoking and a responding entity. The invoking entity is the entity which acts in response to an FC request from an invoking entity.

In defining an FC, the following guidelines should be considered:

- FCs are used as building blocks and may be invoked in order to realize a telecommunication service. FCs will have signalling impact and should be structured in such a way that several telecommunication services can use them. In particular, the definition of an FC should as far as possible be independent of any connection type.
- A new FC should not be defined if its functionality can be provided by one or more existing FCs. As an objective, an FC will not invoke another FC.

The relationship between an FC and EFs is shown in Figure 7/I.310.

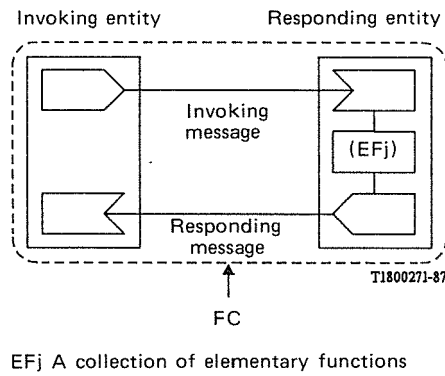

FIGURE 7/I.310

Relationship between an FC and EFs

Once invoked, the responding entity will not be affected by unsolicited inputs from the invoking entity. However, the request for execution of an FC may be cancelled by the invoking entity if the request was received.

It should also be noted that the functionality of an FC could be invoked by a user equipment, i.e. the invoking entity of an FC could be allocated to user equipment. When an FC affects the user-network interface a service description is needed. Figure 8/I.310 illustrates FCs affecting different interfaces, FC1 affecting the user-network interface, FC2 affecting an internal network interface. It also illustrates that the invoking and responding entities of different FCs may appear in the same functional entity.

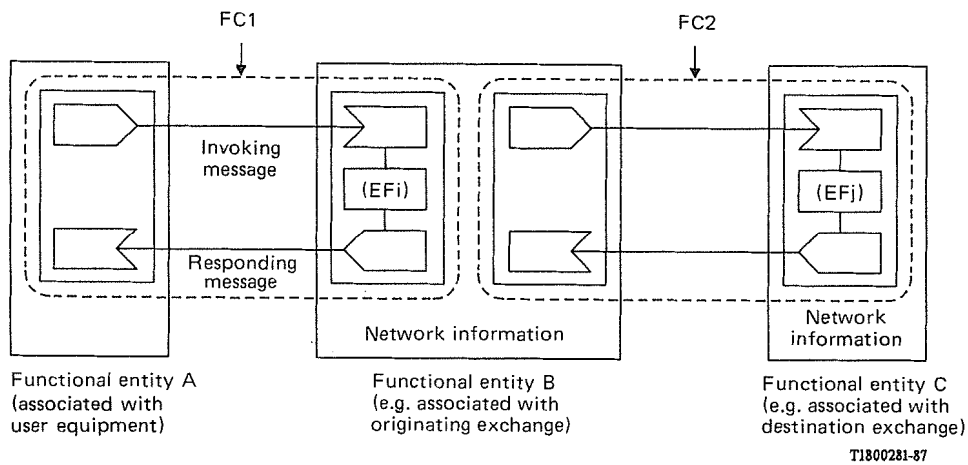

FIGURE 8/I.310

Illustration of multiple FCs affecting different interfaces: FC1 affecting the user-network interface and FC2 affecting the internal network interface

FCs are building blocks, which by themselves are not sufficient to provide a service. There is a need for some logic reflecting how FCs are coordinated in order to support a given service: this logic is termed service control. Service control is an example of the application process concept which can be found in other Recommendations.

Annex B gives descriptions of FCs so far identified for the ISDN.

5 Functional realization of basic service requests

From the functional point of view, the process involved in satisfying a basic service request in the ISDN can be described as follows:

- a) A basic service request contains a set of attribute values. The appropriate connection type(s) to support the service must be identified.

Service request examination:

- input: service request containing a set of attribute values;
- process: examine service request and determine appropriate connection type(s);
- output: connection type(s).

- b) Once selected, the connection type (which has end-to-end significance) can be further broken down into one or more smaller functional components called “connection elements” (see Recommendation I.324).

Connection element selection:

- input: connection type;
- process: determine connection element(s) to form the connection type;
- output: connection element(s).

- c) Each connection element would require a set of functions in order to be established.

Function set determination:

- input: connection element;
- process: select appropriate functions to establish connection element;
- output: set of functions.

ANNEX A

(to Recommendation I.310)

A.1 *List of identified basic elementary functions and additional elementary functions (EFs) for the ISDN*

A.1.1 *BASIC EFs related to connection types*

Connection handling

BEF100	Characteristics of service requested examination
BEF101	Connection elements type determination
BEF102	User-network access resources reservation (channels)
BEF103	Transit resources reservation
BEF104	Communication references handling
104 E:	Establish call reference
104 C:	Clear call reference
BEF105	Establishment control
105 R:	Establish connection-return path only
105 F:	Establish connection-forward path
150 B:	Establish connection-both directions
BEF106	Release control
BEF107	Service related authorizations examination
BEF108	User-network signalling handling (layer 3)
BEF109	Inter-exchange signalling handling (user part)
BEF110	Supplementary services compatibility checking
BEF111	Building up of and maintaining dynamic information relating to the call/connection
BEF112	Signalling interworking
BEF113	Priority
BEF114	Queue handling

Routing

BEF200	ISDN number identification
BEF201	Called number analysis (address analysis)
BEF202	Routing information examination (if provided)
BEF203	Predetermined specific routing
BEF204	Connection path selection
BEF205	Rerouting

Resources handling

BEF300	Hold and release of user-network access resources (channels)
300 H:	Hold user-network access resources
300 R:	Release user-network access resource
BEF301	Hold and release of transit resources (circuits)
301 H:	Hold transit resources
301 R:	Release transit resources
BEF302	Insertion and suppression of specific equipment
BEF303	Tones, announcements and display information
BEF304	User-network signalling handling (layer 1-2)
BEF305	Inter-exchange signalling handling (message transfer)
BEF306	Path search inside switching unit
BEF307	Synchronization handling
BEF308	Timing handling
BEF309	Line service marking
BEF310	Real time clock

Supervision

BEF400	User-network access resources monitoring
BEF401	Transit resources monitoring
BEF402	Continuity checking
BEF403	Detection of congestion
BEF404	Semi-permanent connection checking

Operation and maintenance

BEF500	Management of subscriber data
BEF501	Fault report

Charging

BEF600	Charging management
600 I:	Initiate charging
600 C:	Cease charging
BEF601	Charging registering
BEF602	Charging recording
BEF603	Billing
BEF604	Accounting
BEF605	Charging information

Interworking

BEF700	Rate adaption
BEF701	Protocol conversion
BEF702	Handling of signalling for interworking
BEF703	Numbering interworking
BEF704	Special routing algorithms
BEF705	Negotiation
BEF706	Notification
BEF707	Charging for interworking
BEF708	Mapping of lower layer comparability

A.1.2 *AEFs relating to supplementary services*

AEFOO	Insertion and suppression of additional resources (tones etc.)
AEFOI	Line hunting
AEF02	Direct dialling-in
AEF03	Address determination
AEF04	Subscriber's dedicated storage
AEF05	Bridge
AEF06	User-network access resource hold
AEF07	Hold of communication
AEF08	Additional subscriber signalling
AEF09	Additional inter-exchange signalling
AEF10	Multi-call handling
AEF11	Internal call initialization
AEF12	Access/route restriction
AEF13	Subscriber call data registration
AEF14	Data display option

A.2 *Short description of elementary functions*

A.2.1 *Basic EFs related to connection types*

A.2.1.1 *Connection handling*

100 *Characteristics of service requested examination*

Function of a functional entity to determine the required service characteristics (certain attributes of the bearer service and optional supplementary services) of a call by means of examination of information set by calling terminal.

101 *Connection elements type determination*

Function of a functional entity to determine connection types and connection elements necessary to provide the requested service.

102 *User access resources reservation*

Function of a functional entity to determine the type of user-network access (basic, primary), the state of the resources (channels availability) and to reserve the channel(s) needed for establishing the access connection element.

103 *Transit resources reservation*

Function of a functional entity to reserve the transit connection element, based on the state of resources.

104 *Communication references handling*

Function of a functional entity to assign a local reference (at the access interface) to the call and an internal reference (at the internal interface) to the connection, and to clear these references when the call/connection is cleared/released.

104 E Establish call reference. (For further study.)

104 C Clear call reference. (For further study.)

105 *Establishment control*

Function of a functional entity to set up a connection through the functional entity.

105 R Establish connection-return path only. (For further study.)

105 F Establish connection-forward path. (For further study.)

105 B Establish connection-both direction. (For further study.)

106 *Release control*

Function of a functional entity to release a connection through the functional entity.

107 *Service related authorization examination*

Function of a functional entity to determine the authorization (calling or called user) relating to basic and supplementary services that have been subscribed to.

108 *User-network signalling handling (layer 3)*

Function of a functional entity to support the layer 3 protocol of the user-network signalling system.

Note – For layers 1 and 2, see § A.2.1.3, Resources handling.

109 *Inter-exchange signalling handling (user part)*

Function of a functional entity to support the user part of the inter-exchange signalling system.

110 *Supplementary services compatibility checking*

Function of the network to check the compatibility of requested supplementary services, e.g.:

- with requested bearer service to teleservice;
- with other requested supplementary services;

and to verify coherence between parameters that may be associated.

111 *Building-up of and maintaining dynamic information related to the call/connection*

Function of a functional entity to compile information related to the call/connection, e.g.:

- resources needed (connection type, connection elements, channels, circuits);
- details of call in progress;
- supplementary services effected and associated parameters.

112 *Signalling interworking*

Function of a functional entity to support interworking functions between signalling systems.

113 *Priority*

Function of a functional entity to handle specific calls with priority (e.g. in the case of overload or degraded mode of operation).

114 *Queue handling*

Function of a functional entity to store requests in a queue, in order to handle this information later in a predefined order.

A.2.1.2 *Routing*

200 *ISDN number identification*

Function of a functional entity to identify the ISDN number of the user-network interface. This information is limited to that included within the ISDN numbering plan.

201 *Called number analysis*

Function of a functional entity to analyse called ISDN number sent by the calling terminal in the call set-up phase.

202 *Routing information examination*

Function of a functional entity to analyse routing information that may be sent by the calling terminal and that has an effect on path selection.

203 *Predetermined specific routing*

Function of an exchange to select a specific routing according to the information received from the calling terminal (for example routing towards operators, access points, an interworking unit, an operational or maintenance unit, etc.).

204 *Connection path selection*

Function of a functional entity to select the transit outgoing part relating to connection types to be used, and the overall path through the network.

205 *Rerouting*

Function of a functional entity to select a new connection path through the network depending on changed conditions during call set-up or information transfer phases.

A.2.1.3 *Resources handling*

300 *Hold and release of user-network access resources (channels)*

Function of a functional entity to hold the access channel(s) reserved to support the communication, and to release it at the end of this communication.

300 H Hold user-network access resource. (For further study.)

300 R Release user-network access resource. (For further study.)

301 *Hold and release of transit resources (circuits)*

Function of a functional entity to hold the circuit(s) reserved to support the communication at the transit connection element and to release it at the end of this communication.

301 H Hold transit resources. (For further study.)

301 R Release transit resources. (For further study.)

302 *Insertion and suppression of specific equipment*

Function of a functional entity to insert or remove specific equipments particularly to satisfy the service request invoked by the user. Examples of such equipment include:

- echo suppressers;
- A- μ law conversion units (change of A/D conversion);
- interworking unit;
- storage unit.

303 *Tones, announcements and display information*

Function of a functional entity to provide call progress information in one or more of the following ways:

- a tone is an audible (call progress) indication comprising one or more discrete frequencies but excluding speech;
- a recorded announcement is an audible indication in the form of speech or music;
- display information is (call progress) information set to the user which is displayed visually.

Definitions of the other topics are not yet available.

304 *User-network signalling handling (layers 1-2)*

Functions of a functional entity to support layers 1 and 2 of the user-network signalling system.

305 *Inter-exchange signalling handling (message transfer)*

Function of a functional entity to support the messages transfer part of the inter-exchange signalling systems.

306 *Path search inside switching unit*

Function of a functional entity to select an internal connection inside the switching unit.

307 *Synchronization handling*

Function of a functional entity to provide synchronization between different functional entities; and

Function of a functional entity to provide its own internal synchronization functional entity.

308 *Timing handling*

Function of a functional entity to provide timing between time instances involved in calls.

309 *Line service marking*

Functions of a functional entity to store for each customer the data on the parameters of the bearer and teleservices that are subscribed to. The store also contains the data on the parameters of the basic bearer and teleservices that are subscribed to by the customer. In addition, it contains the binary information (i.e. subscribed to or not) for a range of supplementary services which the subscriber can use. In general this data does not contain information on the type of subscriber terminal, but it may contain information on the type of access (basic, primary rate, etc.), the type of NT2 (simple, intelligent, etc.) and the attributes of the services subscribed to.

310 *Real time clock*

Function of a functional entity to provide real time information.

A.2.1.4 *Supervision*

400 *User-network access resources monitoring*

Function of a functional entity to check the correct operation of subscriber access resources.

401 *Transit resources monitoring*

Function of a functional entity to check the correct operation of the transit resources.

402 *Continuity checking*

Function of a functional entity to control the checking operations relating to the continuity of a connection.

403 *Detection of congestion*

Function of a functional entity to detect congestion during the selection of a connection path.

404 *Semi permanent connection checking*

Function of a functional entity to check the availability of a given semi-permanent connection (e.g. passive continuity checking).

A.2.1.5 *Operation and maintenance*

500 *Management of subscriber data*

Function of a functional entity to manage subscriber data related to services. Examples include:

- in/out of service
- number translation
- changing of subscriber data.

501 *Fault report*

Function of a functional entity to register the cause if an attempt to set up a call fails.

A.2.1.6 *Charging (the groupings below require further study)*

Function of the network to determine, collect and store the charging information. The following features are involved in this process:

600 *Charging management*

Function of a functional entity to determine by means of certain parameters the charging mode (free of charge, ordinary, peak, reduced rate charge, etc.). These parameters include service type, class of customer, time information, distance, etc.

600 I Initiate charging. (For further study.)

600 C Cease charging. (For further study.)

601 *Charging registering*

Function of a functional entity to register the details of the call (both short- and long-term storage).

602 *Charging recording*

Function of a functional entity to format the charging details in a standardized way.

603 *Billing*

Function of functional entity to calculate the variable charges to the customer which depend on the use of a service and on the fixed costs of the subscription. Both of these are accumulated over a fixed period of time. This billing is associated with the subscriber and not with a user-network interface, a terminal, etc.

604 *Accounting*

Function of a functional entity to analyse, store and forward information relating to the use of inter-network resources between the different Administrations involved in a call.

605 *Charging information*

Function of the network to indicate the user the amount of the charge involved in the (current) use of the service.

A.2.1.7 *Interworking*

Functions that permit the establishment of end-to-end connections when an ISDN and a dedicated network are involved. This requires the provision of the basic elementary features (BEFs) which are described below and others that have been defined already (service request examination, signalling interworking, called number analysis, routing information examination, insertion and suppression of interworking units, etc.).

700 *Rate adoption*

Function of a functional entity to adapt, according to a certain method, the user/dedicated network bit rates to the ISDN bit rates.

701 *Protocol conversion*

Function of a functional entity to support mapping functions between interfaces.

702 *Handling of signalling for interworking*

Function of a functional entity to handle signalling information for interworking (interpretation, termination, generation).

703 *Numbering interworking*

Function of a functional entity to support interworking functions between numbering plans.

704 *Special routing algorithms (For further study)*

705 *Negotiation (For further study)*

706 *Notification (For further study)*

707 *Charging for interworking (For further study)*

708 *Mapping of lower layer comparability (LLC) lists (For further study)*

A.2.2 *Additional EFs relating to supplementary services*

AEFOO *Insertion and suppression of additional resources (tone, etc.)*

Note – A definition has already been proposed for a basic EF. It needs to be considered if this feature should also be regarded as an additional feature. With respect to supplementary services a proposed description is:

Function of an exchange to manage (reserve, insert, release) additional resources related to the handling of supplementary services.

AEF01 *Line hunting*

Function of a functional entity to select, on receipt of a certain terminal address, one free line in a multi-line group corresponding to that number.

AEF02 *Direction dialling-in*

Function of a functional entity to transfer address and other appropriate call handling information to a PABX for the purpose of setting up a call to its extensions without assistance of the PABX operator.

AEF03 *Address determination*

Function of a functional entity to determine the destination number(s) called by means of short-long number conversion or of association between one code and one list of numbers.

AEF04 *Subscriber's dedicated storage*

Function of a functional entity to store details in addition to the LSM (line service marking) for each customer and which contains the registration data for supplementary services that have been subscribed to (i.e. listed in the LSM as binary 1). For example, it would contain a list of abbreviated numbers.

AEF05 *Bridge*

Functions of a functional entity to allow more than two individual participants on the same call.

AEF06 *User-network access resource hold*

Function of a functional entity to hold the user-network access resources (channel) involved in a communication in a waiting condition and, at the same time, to release the network connection. The call reference information is maintained.

AEF07 *Hold of communication*

Function of a functional entity to initiate the function to hold one, or more, of the other parties engaged in an established call in a waiting condition without the disestablishment of the call, and at the same time to release the initiating user-network access resource.

AEF08 *Additional subscriber signalling*

Functions of an exchange to send or receive specific signalling information to or from the user, related to the handling of supplementary services. (Additional signalling to the subscriber signalling for basic calls.)

AEF09 *Additional inter-exchange signalling*

Function of a functional entity to send or receive specific signalling information to or from another component, related to the handling of supplementary services. (Additional signalling to the inter-exchange signalling for basic calls.)

AEF10 *Multi-call handling*

Function of a functional entity to set up and manage several connections by means of a single procedure. (In response to only one call request.)

AEF11 *Internal call initialization*

Functions of a functional entity to initiate the setting-up of a connection without receiving a call request from the user [e.g. used for Completion of Call to Busy Subscribers (CCBS) supplementary service and alarm call services].

AEF12 *Access/route restriction*

Function of a functional entity to reject incoming or outgoing calls, either:

- totally for all services, or
- for one type of service (e.g. telephony).

AEF13 *Subscriber call data registration*

Function of a functional entity to register and display or print subscriber call data. Subscriber call data is information related to specific calls. This data is collected by the same functional entity as that which contains the EF "subscriber call data registration".

AEF14 *Data display option*

Functions of a terminal to display information to the user.

ANNEX B

(to Recommendation I.310)

Descriptions of identified functional components (FCs) for the ISDN

B.1 *Hold invocation*

This FC allows to invoke the disconnection of an established communication channel between the initiating and responding entities and its reservation for subsequent reuse for another (or the previous) communication. This implies the interruption of the communication for an existing connection.

The initiating entity provides the information required to identify the connection to be interrupted.

The successful application of this FC results in:

- the disconnection of the communication channel between the initiating and the responding entities;
- the reservation of the disconnected communication channel for the initiating entity (for originating or terminating connections);
- an indication of successful completion from the responding entity.

The unsuccessful application of this FC results in a response containing the failure details.

Note – The exact definition of communication channel is for further study.

B.2 *Retrieve*

This FC allows the initiating entity to request the reconnection of a communication channel between the initiating and responding entities in order to re-establish a previously held connection.

The initiating entity provides the information required to identify the connection to be re-established over the reserved communication channel.

The successful completion of this FC results in:

- the re-establishment of the connection. The communication channel will be the reserved channel whenever possible. If exceptionally an alternate channel had to be allocated, the responding entity will indicate its identity;
- an indication of successful completion from the responding entity.

The unsuccessful application of the FC results in a response containing the failure details.

The possible re-establishment of a connection over another communication channel than the reserved one is for further study.

B.3 *Join*

This FC allows to invoke the addition of a connection in order to form, or to add to, a multiparty connection of the same connection type.

The initiating entity provides all information required to identify the connection to be joined to the multi-party connection. The responding entity executes the functions to join the connection and provides the initiating entity with the information of the result of the execution.

Upon successful completion, all connections involved are connected together. A successful indication is returned to the initiating entity.

Upon unsuccessful completion, the status of last connection remains unchanged and an unsuccessful indication is returned to the initiating party with failure cause(s).

B.4 *Split*

This FC allows the initiating entity to separate a connection from a multiparty connection.

The initiating entity provides the identities of the multiparty connection and the connection to be separated. The responding entity executes the functions to separate the designated connection from the multiparty connection.

Upon successful completion the designated connection is separated from the multiparty connection. The separated connection is put on hold; the remainder of the multiparty connection remains unchanged. A successful indication is returned to the initiating entity.

Upon unsuccessful completion, the status of the multiparty connection remains unchanged and an unsuccessful indication is returned to the initiating party with failure cause(s).

B.5 *Transfer*

This FC allows the initiating entity to reassign the ownership of a call to an elected subscriber.

The initiating entity provides the identity of the connection to be transferred and the identity of the elected subscriber.

Successful completion of this FC results in:

- the elected subscriber assumes the subsequent charges;
- the initiating entity receives a successful confirmation from the responding entity;
- the initiating entity is disconnected from the transferred connection.

Upon unsuccessful completion, the status of the connection remains unchanged and an unsuccessful indication is returned to the initiating party with failure cause(s).

Note – The concept of ownership requires further investigation in relation to control and charging aspects.

B.6 *Notify*

This FC provides the capability for one entity to inform another entity of some action or condition without requiring a response from the receiving entity.

Note – A more precise definition of this FC is required.

B.7 *Enquire*

This FC provides the capability for the initiating entity to request information from another entity, without changing that information.

The initiating entity provides to the responding entity what information is requested and other information the responding entity needs to respond successfully. For example, in requesting information from the responding entity about busy/idle status of an interface, the initiating entity provides information uniquely identifying that interface.

Upon successful completion, the responding entity returns to the initiating entity the requested information.

Upon unsuccessful completion, the responding entity returns an unsuccessful indication including failure cause(s).

B.8 *Adjourn*

This FC provides the capability for the initiating and responding entities to retain knowledge of a call (or call attempt) sufficient for subsequent re-establishment.

The initiating entity provides to the responding entity the identity of the call to be adjourned.

Upon successful completion, all channels previously allocated for the call (or call attempt) are released and the knowledge of the call is retained.

Upon unsuccessful completion, the status of the call remains unchanged and an unsuccessful completion indication with failure cause(s) is returned to the initiating entity.

B.9 *Restart*

This FC provides the capability for the initiating entity to allocate resources to restore an adjourned call.

The initiating entity provides the identity of the adjourned call to be restored.

Upon successful completion, the necessary resources to re-establish the call are restored and the call set-up process resumes.

Upon unsuccessful completion, the adjourned call is released and a failure indication returned to the initiating entity including failure cause(s).

B.10 *Monitor*

This FC allows the initiating entity to watch for an event (e.g. transition to idle, transition to busy) on a resource. The resource being monitored may be a network resource or a user resource.

The initiating entity provides the identity of the resource to be monitored, the event to be reported, and optionally the period of the monitor function. If the event to be monitored is the availability of a resource, the initiating entity may also request the resource be reserved when it becomes available. The responding entity will indicate acceptance or rejection of the monitor request immediately and subsequently check the states of the resource during the period specified.

Upon successful completion, the responding entity will notify the initiating entity if the period expired before the monitored event occurred.

Upon unsuccessful completion, an unsuccessful indication is returned to the initiating entity with failure cause(s).

B.11 *Reroute*

The FC allows the initiating entity to redirect an incoming call to an alternate address before the call is established.

The initiating entity provides the identity of the incoming call and the alternate address to where the incoming call is to be redirected.

Upon successful completion, the incoming call is connected to the alternate address.

Upon unsuccessful completion, the responding entity provides to the initiating entity the cause of failure and the call processing of the incoming call is resumed.

ITU-T RECOMMENDATIONS SERIES

Series A	Organization of the work of the ITU-T
Series B	Means of expression: definitions, symbols, classification
Series C	General telecommunication statistics
Series D	General tariff principles
Series E	Overall network operation, telephone service, service operation and human factors
Series F	Non-telephone telecommunication services
Series G	Transmission systems and media, digital systems and networks
Series H	Audiovisual and multimedia systems
Series I	Integrated services digital network
Series J	Transmission of television, sound programme and other multimedia signals
Series K	Protection against interference
Series L	Construction, installation and protection of cables and other elements of outside plant
Series M	TMN and network maintenance: international transmission systems, telephone circuits, telegraphy, facsimile and leased circuits
Series N	Maintenance: international sound programme and television transmission circuits
Series O	Specifications of measuring equipment
Series P	Telephone transmission quality, telephone installations, local line networks
Series Q	Switching and signalling
Series R	Telegraph transmission
Series S	Telegraph services terminal equipment
Series T	Terminals for telematic services
Series U	Telegraph switching
Series V	Data communication over the telephone network
Series X	Data networks and open system communications
Series Y	Global information infrastructure and Internet protocol aspects
Series Z	Languages and general software aspects for telecommunication systems