



INTERNATIONAL TELECOMMUNICATION UNION

**ITU-T**

TELECOMMUNICATION  
STANDARDIZATION SECTOR  
OF ITU

**J.61**

**(ex CMTT.567)**

**(06/90)**

**TELEVISION AND SOUND TRANSMISSION**

---

**TRANSMISSION PERFORMANCE OF  
TELEVISION CIRCUITS DESIGNED FOR USE  
IN INTERNATIONAL CONNECTIONS**

**ITU-T Recommendation J.61**

(Formerly Recommendation ITU-R CMTT.567)

---

## FOREWORD

The ITU Telecommunication Standardization Sector (ITU-T) is a permanent organ of the International Telecommunication Union. The ITU-T is responsible for studying technical, operating and tariff questions and issuing Recommendations on them with a view to standardizing telecommunications on a worldwide basis.

The World Telecommunication Standardization Conference (WTSC), which meets every four years, established the topics for study by the ITU-T Study Groups which, in their turn, produce Recommendations on these topics.

ITU-T Recommendation J.61 (formerly Recommendation ITU-R CMTT.567) was elaborated by the former ITU-R Study Group CMTT. See Note 1 below.

---

## NOTES

1 As a consequence of a reform process within the International Telecommunication Union (ITU), the CCITT ceased to exist as of 28 February 1993. In its place, the ITU Telecommunication Standardization Sector (ITU-T) was created as of 1 March 1993. Similarly, in this reform process, the CCIR and the IFRB have been replaced by the Radiocommunication Sector (ITU-R).

Conforming to a joint decision by the World Telecommunication Standardization Conference (Helsinki, March 1993) and the Radiocommunication Assembly (Geneva, November 1993), the ITU-R Study Group CMTT was transferred to ITU-T as Study Group 9, except for the satellite news gathering (SNG) study area which was transferred to ITU-R Study Group 4.

2 In this Recommendation, the expression "Administration" is used for conciseness to indicate both a telecommunication administration and a recognized operating agency.

## TRANSMISSION PERFORMANCE OF TELEVISION CIRCUITS DESIGNED FOR USE IN INTERNATIONAL CONNECTIONS

(1978; revised in 1982, 1986 and 1990)

The CCIR,

### CONSIDERING

the need for a Recommendation concerning analogue television transmissions over long distances, common to the CCIR and CCITT,

### UNANIMOUSLY RECOMMENDS

that, taking account of the definitions in Parts A and B and the measurement methods in Part C and its Annexes, the transmission performance of international television circuits should satisfy the objectives for design given in Parts D and E.

### Introduction

The Joint CCIR/CCITT Study Group for Television and Sound Transmission (CMTT) has studied problems which occur when transmitting television signals of various standards over long distances.

The CMTT decided to study unified test methods and transmission performance which can be recommended for circuits intended for transmission of signals conforming to the majority of television standards.

This Recommendation is intended for use where circuits will be required at various times to transmit television signals of the 525-line and the 625-line standards.

However, in view of the comprehensive nature of the Recommendation, it is appropriate that it also be applicable to circuits which are required to transmit television signals of only one standard. Accordingly, the document addresses the different requirements of 525-line, 625-line and multi-standard needs where necessary.

The assumption is made that the circuit does not contain satellite systems using line-rate energy dispersal or systems which employ digital transmission techniques. If it does, it is probable that additional objectives will be required.

The Recommendation contains five parts listed below:

Part A: Definitions of a connection and circuits

Part B: Definition of parameters

Part C: Measurement methods and test signals

Part D: Design objectives and tolerances applicable to the hypothetical reference circuit

Part E: Performance of circuits shorter or longer than the hypothetical reference circuit.

*Note* – References and Bibliography are detailed at the end of the particular Part or Annex to which they are relevant.

### PART A – DEFINITION OF AN INTERNATIONAL TELEVISION CONNECTION AND DEFINITION OF THE TERRESTRIAL AND COMMUNICATION SATELLITE HYPOTHETICAL REFERENCE CIRCUITS

#### A.1 Definitions

##### A.1.1 *Definition of an international television connection* (Fig. 1)

- Point A, to be considered as the sending end of the international television connection, may be the point at which the programme originates (studio or outside location), a switching centre or the location of a standards converter.
- Point D, to be considered as the receiving end of the international television connection, may be a programme-mixing or recording centre, a broadcasting station, a switching centre or the location of a standards converter.

---

<sup>1)</sup> Formerly Recommendation ITU-R CMTT.567.

- The local television circuit AB connects point A to the sending terminal station, point B, of the international television circuit.

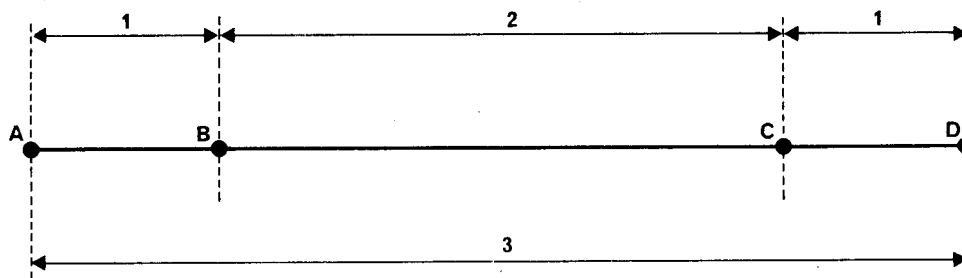

FIGURE 1 – An international television connection

- 1 : Local television circuit
- 2 : International television circuit
- 3 : International television connection

d01-sc

- The international television circuit, BC, comprises a chain of national and international television links. The precise locations (e.g. within buildings), to be regarded as the points B and C, will be designated by the authorities concerned.
- The local television circuit CD connects point C, the receiving terminal station of the international television circuit, to the point D.
- The combination AD, of the international television circuit, BC, and the local television circuits AB and CD, constitutes the international television connection.

The requirements given in subsequent parts of this Recommendation refer to the performance of international television circuits only; no requirements have been laid down for the local television circuits, AB and CD.

A.1.2 *Definition of the terrestrial hypothetical reference circuit (Fig. 2a)*

The main features of the television terrestrial hypothetical reference circuit, which is an example of an international television circuit (BC in Fig. 1) and which may be of either radio or cable type, are:

- the overall length between video terminal points is 2500 km;
- two intermediate video points (M and M') divide the circuit into three sections of equal length;
- the three sections are lined up individually and then interconnected without any form of overall adjustment or correction;
- the circuit does not contain a standards converter or a synchronizing pulse regenerator, or an equipment for the insertion of signals in the line/field blanking interval.

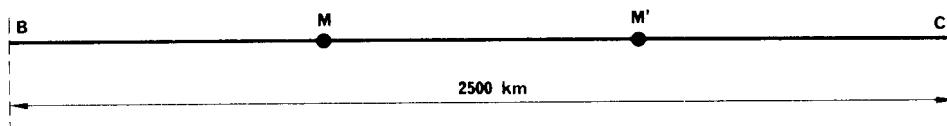

FIGURE 2a – Hypothetical reference circuit for television transmissions over a terrestrial system

d02-sc

A.1.3 *Definition of the hypothetical reference circuit in the fixed satellite service (Fig. 2b)*

A hypothetical reference circuit for a system in the fixed satellite service which may form part of an international television circuit (BC in Fig. 1) is defined as follows:

- it consists of one Earth station-satellite-Earth station system;
- it includes one pair of modulation and demodulation equipments for translation from the baseband to the radio-frequency carrier, and from the radio-frequency carrier to the baseband, respectively;
- it does not include a standards converter or a synchronizing-pulse regenerator, or equipment for the insertion of signals in the line/field blanking interval.

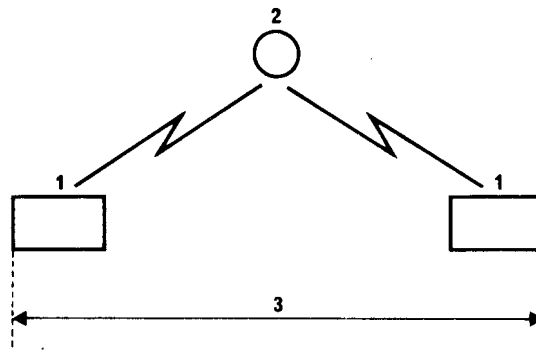

FIGURE 2b – Hypothetical reference circuit for television transmissions over a system in the fixed satellite service

- 1: Earth station
- 2: Satellite space station
- 3: Hypothetical reference circuit

d03-sc

## PART B – DEFINITIONS OF PARAMETERS

This part defines terms which are necessary for the understanding of the Recommendation itself. The definitions are necessary either because many of them do not appear in any recognized technical vocabulary or because they are general definitions which have been given meanings which are particular to television transmission. Their use in this limited context should not be taken as a restriction on their use in the International Electrotechnical Vocabulary (IEV) or other vocabularies where they may be given wider definitions, i.e. not limited to television.

### B.1 Waveform terminology

The following terms concerning the components and values of a composite colour video signal are illustrated in Fig. 3:

- A : the non-useful d.c. component,
- B : the useful d.c. component, integrated over a complete frame period,
- C : the picture d.c. component, integrated over the active line period ( $T_u$ ),
- D : the instantaneous value of the luminance component,
- E : the instantaneous signal value with respect to the bottom of the synchronizing pulses,
- F : the peak signal amplitude (positive or negative with respect to blanking level),
- G : the peak amplitudes of chrominance components,
- H : the peak-to-peak signal amplitude,
- J : the difference between black level and blanking level (set-up),
- K : the peak-to-peak amplitude of the colour burst,
- L : the nominal value of the luminance component,
- M : the peak-to-peak amplitude of a monochrome composite video signal ( $M = L + S$ ),
- S : the amplitude of the synchronizing pulses,
- $T_{sy}$  : duration of line synchronizing pulse,
- $T_{lb}$  : duration of line blanking period,
- $T_u$  : duration of active line period,
- $T_b$  : duration of breezeway,
- $T_{fp}$  : duration of front porch,
- $T_{bp}$  : duration of back porch.

The amplitudes  $L$ ,  $S$  and  $M$  are used as reference amplitudes for the video signal. The amplitudes defined by  $B$ ,  $C$ ,  $D$ ,  $E$ ,  $F$ ,  $G$ ,  $H$  and  $J$  above, may be expressed as percentages of the value  $L$ .

Average picture level (APL) is the mean value of  $C$  over a complete frame period (excluding blanking periods) expressed as a percentage of  $L$ .

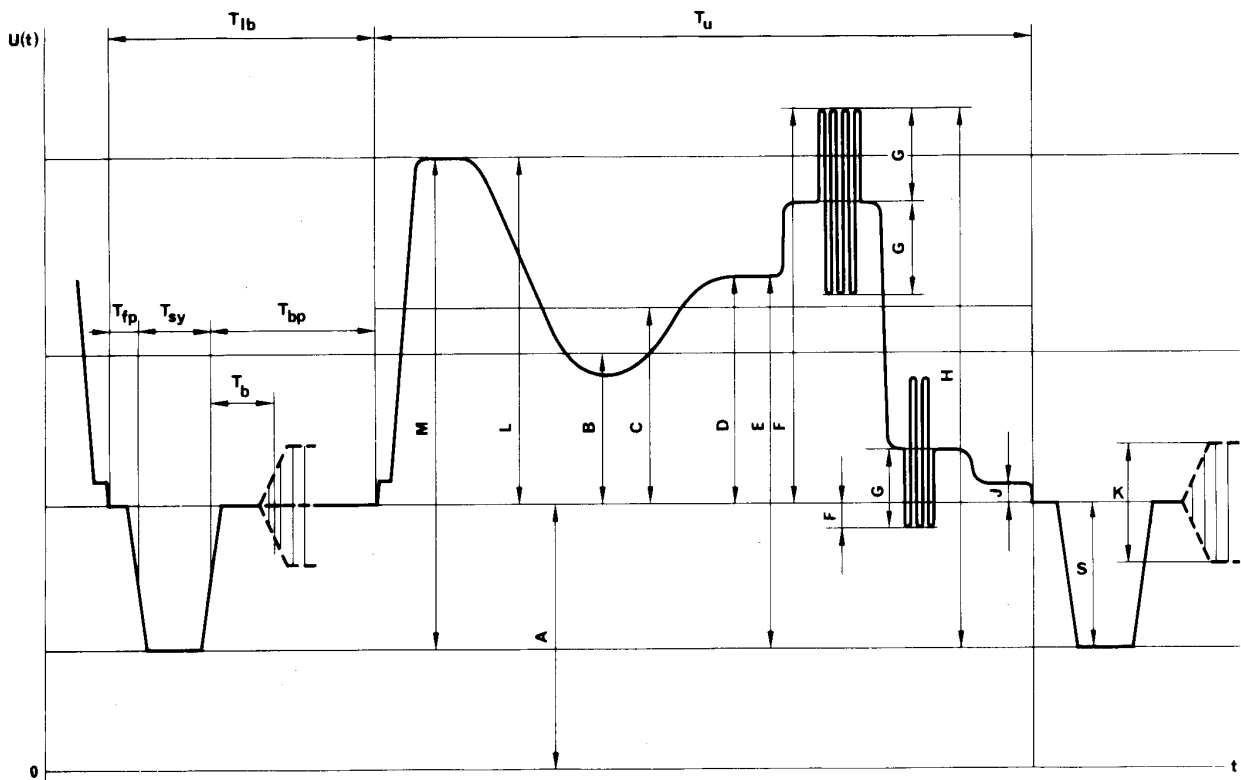

FIGURE 3 – One line of a composite colour video signal

d04-sc

## B.2 Requirements at points of video interconnection

### B.2.1 Nominal impedance ( $Z_0$ )

At points of video interconnection, the input and output impedance ( $Z_0$ ) of each section should be specified, subject to bilateral agreement, as either unbalanced or balanced with respect to earth.

### B.2.2 Return loss

The return loss, relative to  $Z_0$ , of an impedance  $Z$  is, in the frequency domain:

$$20 \log \left| \frac{Z_0 + Z(f)}{Z_0 - Z(f)} \right| \quad \text{dB}$$

In the time domain, it is expressed by the symbolic formula:

$$20 \log \left| \frac{A_1}{A_2} \right| \quad \text{dB}$$

where  $A_1$  is the peak-to-peak amplitude of the incident signal and  $A_2$  is the peak-to-peak amplitude of the reflected signal. Numerically, the result is the same as that obtained by the frequency domain method if the return loss is independent of frequency.

### B.2.3 *Polarity and d.c. component*

The polarity of the signal should be “positive”, that is to say, such that black-to-white transitions are positive-going.

The useful d.c. component,  $B$  in Fig. 3, which is related to the average luminance of the picture, may or may not be contained in the signal and need not be transmitted or delivered at the output.

A non-useful d.c. component,  $A$  in Fig. 3, may be present in the signal (for example, due to d.c. supplies). Limits for this component need to be specified for the terminated and unterminated conditions.

### B.2.4 *Nominal signal amplitude*

The nominal signal amplitude is the peak-to-peak amplitude of the monochrome video signal that includes the synchronizing signal and luminance signal component set to peak-white ( $M$  in Fig. 3).

## B.3 **Transmission performance requirements**

The definitions in § B.3.2 and the subsequent sub-sections assume that the circuit has nominal insertion gain as defined in § B.3.1 below.

### B.3.1 *Insertion gain*

Insertion gain is defined as the ratio, expressed in decibels, of the peak-to-peak amplitude of a specified test signal at the receiving end to the nominal amplitude of that signal at the sending end, the peak-to-peak amplitude being defined as the difference between the amplitudes measured at defined points of the signal used.

### B.3.2 *Noise*

#### B.3.2.1 *Continuous random noise*

The signal-to-noise ratio for continuous random noise is defined as the ratio, expressed in decibels, of the nominal amplitude of the luminance signal,  $L$  in Fig. 3, to the r.m.s. amplitude of the noise measured after band limiting. A signal-to-weighted-noise ratio is defined as a ratio, expressed in decibels, of the nominal amplitude of the luminance signal,  $L$  in Fig. 3, to the r.m.s. amplitude of the noise measured after band limiting and weighting with a specified network.

The measurement should be made with an instrument having, in terms of power, a defined time constant or integrating time.

#### B.3.2.2 *Low-frequency noise*

The signal-to-noise ratio for low-frequency noise is defined as the ratio, expressed in decibels, of the nominal amplitude of the luminance signal,  $L$ , in Fig. 3, to the peak-to-peak amplitude of the noise after band limiting to include only the spectrum 500 Hz to 10 kHz.

#### B.3.2.3 *Periodic noise*

The signal-to-noise ratio for periodic noise is defined as the ratio, expressed in decibels, of the nominal amplitude of the luminance signal,  $L$  in Fig. 3, to the peak-to-peak amplitude of the noise. Different values are specified for noise at a single frequency between 1 kHz and the upper limit of the video frequency band and for power-supply hum including lower-order harmonics.

#### B.3.2.4 *Impulsive noise*

The signal-to-noise ratio for impulsive noise is defined as the ratio, expressed in decibels, of the nominal amplitude of the luminance signal,  $L$  in Fig. 3, to the peak-to-peak amplitude of the impulsive noise.

### B.3.3 *Cross-talk from another television channel*

The signal-to-cross-talk ratio is defined as the ratio, expressed in decibels, of the nominal amplitude of the luminance signal ( $L$  in Fig. 3) to the peak-to-peak amplitude of the interfering signal.

### B.3.4 *Non-linear distortion*

In a television circuit the transmission characteristic may not be completely linear. The extent of the non-linear distortion which is produced will depend primarily on:

- the average picture level, as defined in § B.1;
- the instantaneous value of the luminance signal voltage ( $D$  in Fig. 3);
- the amplitude of the chrominance signal ( $G$  in Fig. 3).

There would, in general, be little purpose in defining completely the non-linear characteristics of a transmission circuit. It is necessary, therefore, to limit the number of measured quantities by restricting them to those which are recognized as being directly correlated with picture quality. Additionally, the test conditions should be restricted by introducing a systematic classification in the definition of the quantities to be measured. Examples of distortions not included in this classification are given in the documentation [CCIR, 1970-74a and b].

The nature of the video signal is such that, in terms of picture quality, the impairment due to the effect of circuit non-linearity on the synchronizing signal is different from the effect of circuit non-linearity on the picture signal.

Furthermore, the non-linearity may affect the luminance and chrominance signals individually or cause interaction between them. This leads to the following system of classification of non-linear distortions:

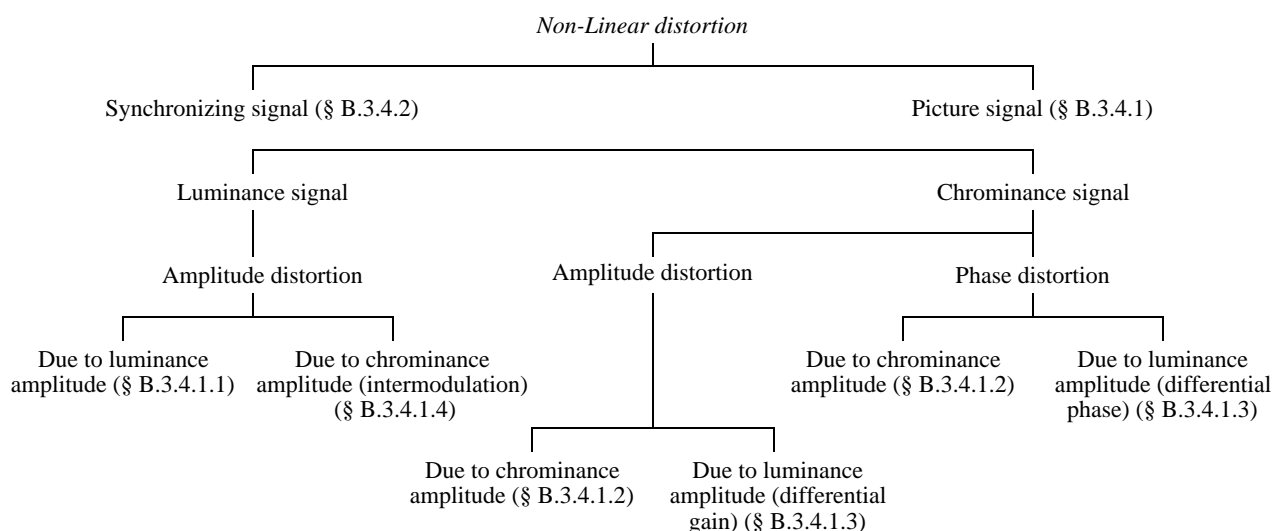

The above classification applies for steady-state conditions during a time span which is long in relation to the field period. In this case, the concept of average picture level has a precise significance. If these conditions are not fulfilled, for example, if a sudden change in the APL is introduced, additional non-linear effects may be produced, the extent of which will depend on the long-time transient response of the circuit. This aspect requires further study (see Study Programme 13B/CMTT, Report 636 and [CCIR, 1970-74c, d, and e]).

Additional non-linearity may also occur if a sudden change in signal amplitude occurs [CCIR, 1970-74a].

### B.3.4.1 *Picture signal*

#### B.3.4.1.1 *Luminance signal*

For a particular value of average picture level, the non-linear distortion of the luminance signal is defined as the departure from proportionality between the amplitude of a small step function at the input to the circuit and the corresponding amplitude at the output, as the initial level of the step is shifted from blanking level to white level.

#### B.3.4.1.2 *Chrominance signal*

##### *Gain*

For fixed values of luminance signal amplitude and average picture level, the non-linear gain distortion of the chrominance signal is defined as the departure from proportionality between the amplitude of the chrominance sub-carrier at the input to the circuit and the corresponding amplitude at the output, as the amplitude of the sub-carrier is varied from a specified minimum to a maximum value.

##### *Phase*

For fixed values of luminance signal amplitude and average picture level, the non-linear phase distortion of the chrominance signal is defined as the variation in the phase of the chrominance sub-carrier at the output, as the amplitude of the sub-carrier is varied from a specified minimum to a maximum value.



### B.3.4.1.3 Intermodulation from the luminance signal into the chrominance signal

#### Differential gain

If a constant small amplitude of chrominance sub-carrier, superimposed on a luminance signal, is applied to the input of the circuit, the differential gain is defined as the change in the amplitude of the sub-carrier at the output as the luminance varies from blanking level to white level, the average picture level being maintained at a particular value.

#### Differential phase

If a constant small amplitude of chrominance sub-carrier without phase modulation, superimposed on a luminance signal, is applied to the input of the circuit, the differential phase is defined as the change in the phase of the sub-carrier at the output as the luminance varies from blanking level to white level, the average picture level being maintained at a particular value.

### B.3.4.1.4 Intermodulation from the chrominance signal into the luminance signal

If a luminance signal of constant amplitude is applied to the input of a circuit, the intermodulation is defined as the variation of the amplitude of the luminance signal at the output resulting from the superimposition on the input signal of a chrominance signal of specified amplitude, the average picture level being maintained at a particular value.

### B.3.4.2 Synchronizing signal

#### B.3.4.2.1 Steady-state distortion

If a video signal of specified average picture level and containing synchronizing pulses of nominal amplitude ( $S$  in Fig. 3) is applied to the input of the circuit, the steady state non-linear distortion is defined as the departure from nominal of the mid-point amplitude of the synchronizing pulses at the output.

#### B.3.4.2.2 Transient distortion

If the average picture level of the video signal is stepped from a low value to a high value, or from a high value to a low value, the transient non-linear distortion is defined as the maximum instantaneous departure from the nominal value of the mid-point amplitude of the synchronizing pulses at the output.

### B.3.5 Linear distortion

Linear distortions are those which can be caused by linear networks. Such distortions do not depend on the average picture level, or the amplitude, or the position of the test signals.

In the case of networks which are affected by a small amount of non-linearity, measurements can still be carried out. However, as the results can be somewhat affected by the average picture level and the amplitude and position of the test signals, it is good practice, when presenting the results, to specify the measurement conditions.

Linear distortions can be measured either in the time domain or in the frequency domain.

The quantities which can be measured in the two domains may be classified as shown below.

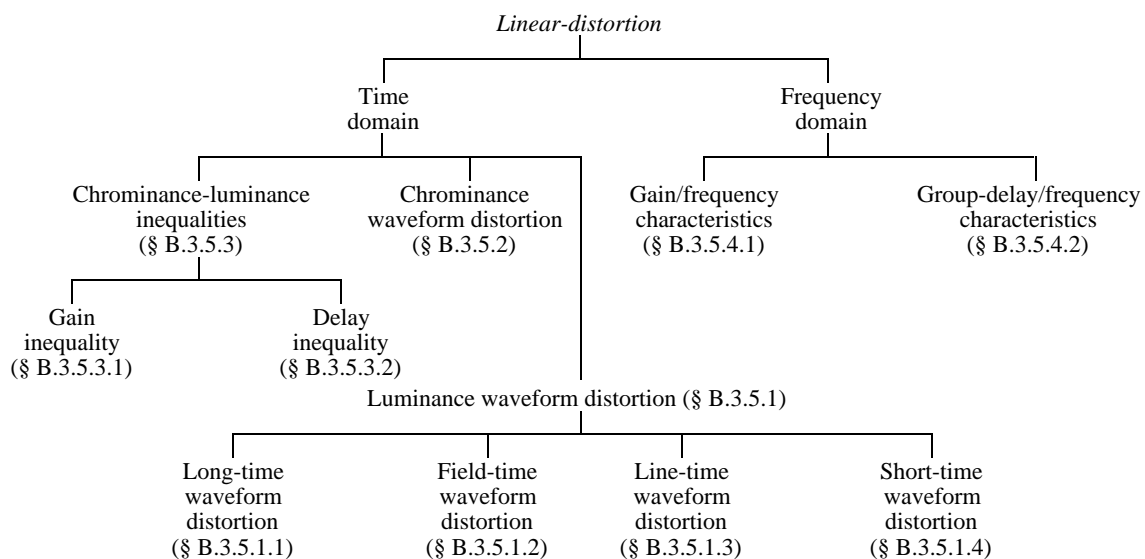

### B.3.5.1 *Waveform distortion of the luminance signal*

The distortion of the video waveform due to a television circuit will in general be represented by a continuous function in the time domain.

In practice, however, the form of the video signal and the effects on a displayed picture are such that the resulting impairments may be classified by considering four different time scales which are comparable to the durations of many fields (long-time waveform distortion), one field (field-time waveform distortion), one line (line-time waveform distortion), and one picture element (short-time waveform distortion).

In considering each of these time scales, therefore, impairments appropriate to the other three are excluded by the measurement method.

#### B.3.5.1.1 *Long-time waveform distortion*

If a video test signal, simulating a sudden change from a low average picture level to a high one or a high average picture level to a low one, is applied to the input of a circuit, long-time waveform distortion is present if the blanking level of the output signal does not accurately follow that of the input. This failure may be either in exponential form or, more frequently, in the form of damped very low-frequency oscillations.

#### B.3.5.1.2 *Field-time waveform distortion*

If a square-wave signal with a period of the same order as one field and of nominal luminance amplitude is applied to the input of the circuit, the field-time waveform distortion is defined as the change in shape of the square wave at the output. A period at the beginning and end of the square wave, equivalent to the duration of a few lines, is excluded from the measurement.

#### B.3.5.1.3 *Line-time waveform distortion*

If a square-wave signal with a period of the same order as one line and of nominal luminance amplitude is applied to the input of the circuit, the line-time waveform distortion is defined as the change in shape of the square wave at the output. A period at the beginning and end of the square wave, equivalent to a few picture elements, is excluded from the measurement.

#### B.3.5.1.4 *Short-time waveform distortion*

If a short pulse (or a rapid step-function) of nominal luminance amplitude and defined shape is applied to the input of the circuit, the short-time waveform distortion is defined as the departure of the output pulse (or step) from its original shape. The choice of the half-amplitude duration of the pulse (or the rise-time of the step) will be determined by the nominal cut-off frequency,  $f_c$ , of the television system. (See Report 624.)

### B.3.5.2 *Chrominance waveform distortion*

If a test signal in the form of an amplitude-modulated sub-carrier is applied to the input of a circuit, chrominance waveform distortion is defined as the change in the shape of the envelope and phase of the modulated sub-carrier of the output test signal.

### B.3.5.3 *Chrominance-luminance inequalities*

#### B.3.5.3.1 *Gain inequality*

If a test signal having defined luminance and chrominance components is applied to the input of the circuit, the gain inequality is defined as the change in amplitude of the chrominance component relative to the luminance component between the input and output of the circuit.

#### B.3.5.3.2 *Delay inequality*

If a composite signal, consisting of a defined luminance test signal in fixed amplitude and time relationship with a chrominance sub-carrier modulated by the same luminance test signal, is applied to the input of the circuit and if the luminance signal at the output is compared with the modulation envelope of the chrominance signal, then the delay inequality of the circuit is defined as the change in relative timing of corresponding parts of the two waveforms between input and output.

### B.3.5.4 *Steady state characteristics*

B.3.5.4.1 The gain/frequency characteristic of the circuit is defined as the variation in gain between the input and output of the circuit over the frequency band extending from the field repetition frequency to the nominal cut-off frequency of the system, relative to the gain at a suitable reference frequency.

B.3.5.4.2 The group delay/frequency characteristic of the circuit is defined as the variation in group delay between the input and the output of the circuit, over the frequency band extending from the field repetition frequency to the nominal cut-off frequency of the system, relative to the delay at a suitable reference frequency. It is for practical reasons, an approximation to the slope (derivative) of the phase/frequency characteristic of the circuit.

## REFERENCES

### *CCIR Documents*

[1970-74]: **a.** CMTT/188 (Germany (Federal Republic of)); **b.** CMTT/189 (Germany (Federal Republic of)); **c.** CMTT/5 (United Kingdom); **d.** CMTT/21 (USA); **e.** CMTT/40 (Germany (Federal Republic of)).

## PART C – MEASUREMENT METHODS AND TEST SIGNALS

### **C.1 Introduction**

Section numbering in this part is related to the section numbering of Part B.

The test signal elements contained in Annex I may be combined in any suitable way to form test signals. Unless otherwise specified, the average picture level of test signals so obtained should be 50%. It should be noted that some practical circuits require the presence of synchronizing signals for correct functioning.

Test signals can be used either as repetitive signals or, with certain exceptions, as insertion test signals in connection with active lines chosen to give the required average picture level. During programme periods however, due consideration must be given to the effects of the variations of the average picture level upon measurements made with insertion test signals.

For full-field tests, some administrations may wish to use full-field sequences containing the same signals as specified for use as insertion test signals (Recommendation 473). In this case, measurement methods should be those specified in Annex III to Part C of this Recommendation.

The measurements described in § C.3.2 to C.3.5 are valid provided that the insertion gain of the circuit is within the stated requirements.

Circuit non-linearity may introduce into the received signals spectral components which are not present in the original test signals and which are not related to picture impairment. In such cases, it is suggested that a phase-corrected low-pass filter be inserted before the measuring equipment to eliminate spurious out-of-band components. An example of a filter suitable for 625-line measurements is described elsewhere [CCIR, 1970-74a].

### **C.2 Measurements of equipment and signal characteristics at points of video interconnection**

#### *C.2.1 Nominal impedance*

At points of video interconnection, the input and output impedance will be specified. The actual impedances will be measured, in terms of departure from the nominal value, by the return loss.

#### *C.2.2 Return loss*

Return loss may be measured in the time domain or in the frequency domain. If the return loss to be measured is independent of frequency both methods will yield the same numerical result.

To measure return loss in the time domain, test signal elements *A*, *B1*, *B2* or *B3*, and *F* shall be used. The return loss is the ratio of the incident to the reflected test signal element, both being measured in peak-to-peak terms. The return loss for each of the above four test signal elements shall be equal to, or greater than, the value specified in Part D.

To measure return loss in the frequency domain, any of several well-established methods may be used. The return loss at all frequencies within the nominal bandwidth of the television system shall be equal to, or greater than, the value specified in Part D.

*Note* – Care should be taken to ensure that any spectral components produced by the test signal source above the nominal cut-off frequency,  $f_c$ , of the television system are attenuated by at least 40 dB relative to components below  $f_c$ .

### C.2.3 *Non-useful d.c. component*

A signal consisting of synchronizing pulses and blanking-level is used. The potential of the blanking-level with respect to earth is measured with a d.c.-coupled instrument.

### C.2.4 *Nominal signal amplitude*

The nominal signal amplitude at points of interconnection is specified in Part D. Conformity with this specification should be assessed by measurement of a composite video signal which contains element *B2* or *B3*.

## C.3 **Measurements of transmission performance**

### C.3.1 *Insertion gain*

The signal element used is *B3* for 625-line systems and *B2* or *B3* for 525-line systems. The amplitude *L* is measured between the centre of the bar (point  $b_2$  in Fig. 4) and blanking level (point  $b_1$  in Fig. 4). The resulting value of the received signal must remain inside the limits specified in Part D.

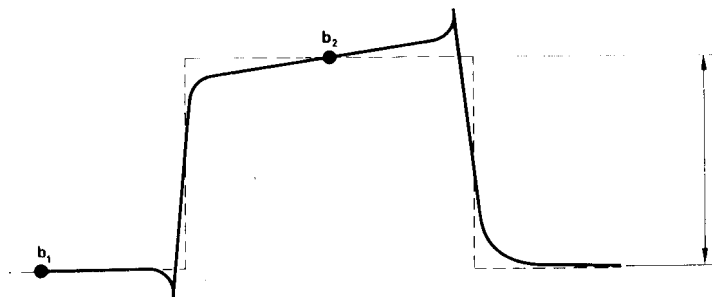

FIGURE 4 – *Insertion gain measurement*

d05-sc

### C.3.2 *Noise*

#### C.3.2.1 *Continuous random noise*

##### *Measuring equipment*

In general, measurements should be made with r.m.s.-reading instruments. Depending on the type of instrument to be used, the circuit will carry either no signal or a specified repetitive signal. The latter case may be used if clamping devices have to be activated. For power measurement, the measuring instrument should have, an effective time constant or integrating time of approximately 1 s.

In some cases it may be desirable to precede the noise measuring equipment by a sub-carrier notch filter, so as to eliminate any sub-carrier periodic noise component from the random noise measurement. Consideration must however be given to the effect of such a filter upon the accuracy of measurement.

When the measurements are made by assessing the quasi peak-to-peak amplitude of the noise, administrations are asked to determine the peak factor appropriate for their measuring methods and to express the results in terms of r.m.s. noise amplitude.

##### *Band limiting*

The measuring instrument should be preceded by band-limiting filters (see § 1 and 2 of Annex II to Part C of this Recommendation). The lower band limit is such that power-supply hum and microphonic noise are excluded. The upper limit is so selected as to eliminate noise which occurs outside the wanted band of the video signal.

If the circuit carries a signal, band limiting may be necessary, using a 200 kHz high-pass filter, as described in Annex III to Part C of this Recommendation.

##### *Weighting*

The measuring instrument should also be preceded by a unified weighting network (see § 3 of Annex II to Part C of this Recommendation).

### C.3.2.2 *Low-frequency noise*

Low-frequency noise voltages are usually measured by means of an oscilloscope. The measuring instrument should be preceded by a band-pass filter. The low-pass section of this filter can be as described in § 2 of Annex II to Part C of this Recommendation. In cases where line-frequency synchronizing pulses are required on the circuit under test and where field frequency synchronizing pulses can be omitted, the sharp cut low-pass filter described in [CCIR, 1970-74b] may be preferred. The high-pass section of the filter requires further study.

### C.3.2.3 *Periodic noise*

Conventional measuring methods may be used. Measurements of power supply hum including lower-order harmonics should be made through the low-pass filter described in § 2 of Annex II to Part C of this Recommendation. In cases where line-frequency synchronizing pulses are required on the circuit under test and where field-frequency synchronizing pulses can be omitted, the sharp cut low-pass filter described in [CCIR, 1970-74b], may be preferred.

When the frequency of the periodic noise is higher, selective measurement may be necessary for the separation of random noise from periodic noise.

### C.3.2.4 *Impulsive noise*

Impulsive noise voltages are measured by means of an oscilloscope.

## C.3.3 *Cross-talk from another television channel*

The mechanism which produces cross-talk noise may be dependent upon a signal being transmitted on the disturbed circuit. Accordingly, measurements should be made both with and without a signal on the disturbed circuit.

Suitable combinations of elements *B1*, *B2*, *B3* and *F* may be used.

Different values are specified, depending on whether the cross-talk appears more or less uniformly throughout the frequency range of the interfering signal or selectively (differentially), affecting mainly the higher frequencies in the range.

## C.3.4 *Non-linear distortion*

### C.3.4.1 *Picture signal*

#### C.3.4.1.1 *Luminance signal*

Luminance non-linearity is measured using the 5-riser staircase test signal element (*D1*) shown in Figs. 11 and 12. At the receiving end, the test signal is passed through a differentiating and shaping network whose effect is to transform the staircase into a train of 5 pulses (by way of example, Annex II (§ 4) to this Part of the Recommendation shows a possible filter, the response of which approximates the sine-squared shape).

Comparing the amplitudes of the pulses, the numerical value of the distortion is found by expressing the difference between the largest and the smallest amplitude as a percentage of the largest.

*Note* – Some administrations may, on an interim basis, use CCIR Test Signal No. 3 (Recommendation 421-3, Geneva, 1974) instead of the 5-riser test signal.

#### C.3.4.1.2 *Chrominance signal*

Chrominance non-linearity is measured with the 3-level chrominance signal shown in Figs. 15 (*G2*) and 16.

#### *Gain*

Gain non-linearity is defined as the larger of the two values in % obtained by substituting  $i = 1$  or  $i = 3$  in the expression:

$$100 \times \left| \frac{A_i - k_i A_2}{k_i A_2} \right|$$

where,

*A* : amplitude of received sub-carrier,

*i* : position of burst on signal *G* or *G2* (1 being the smallest, 3 the largest),

$k_i = \frac{2i - 1}{3}$  for 625-line signal *G2*

$k_i = 2^{i-2}$  for 525-line signal *G*.

It is desirable that the chrominance-luminance gain inequality of the circuit should be within the stated requirements when this measurement is made.

Signal amplitudes should be measured peak-to-peak. A sub-carrier bandpass filter is of assistance in carrying out the measurement.

#### Phase

Phase non-linearity is defined as the largest difference (in degrees) obtained by comparing the phase of the three bursts in the received signal  $G$  or  $G2$ .

If a vector display is used, it is convenient to normalize the phase of the smallest burst.

#### C.3.4.1.3 Intermodulation from the luminance signal into the chrominance signal (Differential gain, differential phase)

Intermodulation is measured with the test signal element  $D2$  shown in Figs. 11 and 12, consisting of a 5-riser staircase with superimposed sub-carrier. At the receiving end, the sub-carrier is filtered from the rest of the test signal and its six sections are compared in amplitude and phase.

*Note* – Some administrations may, on an interim basis, use a modified version of CCIR Test Signal No. 3 (Recommendation 421-3, Geneva, 1974) with superimposed colour sub-carrier.

#### Differential gain

Differential gain is expressed by two values,  $+x$  % and  $-y$  %, which represent the maximum (peak) differences in amplitude between the sub-carrier on the treads of the received test signal and the sub-carrier on its blanking level, expressed as a percentage of the latter. In the case of a monotonic characteristic either  $x$  or  $y$  will be zero.

Differential gain in % referred to blanking level, can be found from the expressions below:

$$x = 100 \left| \frac{A_{max}}{A_0} - 1 \right| \qquad y = 100 \left| \frac{A_{min}}{A_0} - 1 \right|$$

Peak-to-peak differential gain can be found from the expression:

$$x + y = 100 \left| \frac{A_{max} - A_{min}}{A_0} \right|$$

where,

$A_0$  : amplitude of the received sub-carrier at blanking level;

$A$  : amplitude of the sub-carrier on any relevant tread of the staircase between 0 (blanking level tread) and 5 (top tread) inclusive.

*Note* – Some administrations use methods in which the denominator in the above expressions for  $x$  and  $y$  is  $A_{max}$  rather than  $A_0$ . Results obtained by this method will differ only slightly from those defined above if the magnitude of distortion is not excessive.

#### Differential phase

Differential phase is expressed by two values,  $+x$  and  $-y$ , in degrees, which represent the maximum (peak) differences in phase between the sub-carrier on the treads of the received test signal, and the sub-carrier on its blanking level expressed in degrees difference from the latter. In the case of a monotonic characteristic either  $x$  or  $y$  will be zero.

Differential phase in degrees referred to blanking level can be found from the expression below:

$$x = \left| \Phi_{max} - \Phi_0 \right| \qquad y = \left| \Phi_{min} - \Phi_0 \right|$$

Peak-to-peak differential phase can be found from the expression:

$$x + y = \left| \Phi_{max} - \Phi_{min} \right|$$

where,

$\Phi_0$  : phase of the received sub-carrier at blanking level;

$\Phi$  : phase of sub-carrier on any relevant tread of the staircase between 0 (blanking level tread) and 5 (top tread) inclusive.

#### C.3.4.1.4 *Intermodulation from the chrominance signal into the luminance signal*

Chrominance-luminance intermodulation is measured on element *G*, *G1* or *G2* after suppressing the incoming colour sub-carrier. It is defined as the difference between the luminance amplitude in element *G1*, or in the last section of element *G* or *G2* ( $b_5$  in Figs. 15 and 16) and the amplitude of the succeeding section ( $b_6$  in Figs. 15 and 16) in which the test signal has no sub-carrier, expressed as percentage of the luminance bar amplitude.

#### C.3.4.2 *Synchronizing signal*

##### C.3.4.2.1 *Steady-state distortion*

Synchronizing signal steady-state non-linear distortion may be measured using any test signal which will allow the requisite values of average picture level to be obtained.

The distortion is expressed as the difference between sync. amplitude and its normalized value (i.e. 3/7 luminance bar amplitude for 625-line systems, 4/10 luminance bar amplitude for 525-line systems), expressed as a percentage of the normalized value. Measurement is made between the mid-point amplitude of the synchronizing pulse and the mean blanking level.

##### C.3.4.2.2 *Transient distortion*

Measurement method and test signal are still under study.

#### C.3.5 *Linear distortion*

##### C.3.5.1 *Waveform distortion of the luminance signal*

Practical circuits sometimes exhibit amplitude-dependent distortions which show up as linear distortions and which are not detected by the normal non-linear distortion measurement methods [CCIR, 1970-74c and d].

###### C.3.5.1.1 *Long-time waveform distortion*

Long-time waveform distortion usually deserves consideration only when it assumes the form of a damped, very low-frequency oscillation. It can be measured using any test signal which will allow an adequate change of average picture level to be obtained.

Three parameters can be measured:

- the peak amplitude of the overshoot of the signal (expressed as a percentage of nominal luminance amplitude);
- the time taken for the oscillation to decay to a specified value;
- the slope at the beginning of the phenomenon, expressed in %/s.

###### C.3.5.1.2 *Field-time waveform distortion*

Field-time waveform distortion is measured with the field-frequency square wave (signal *A*) shown in Figs. 5 and 6a. The magnitude of the distortion is obtained from the maximum departure in level of the bar top from the level at the centre of the bar expressed as a percentage of the bar amplitude as its centre. The first and last 250  $\mu$ s (approximately 4 lines) are neglected in this measurement.

Alternatively, field-time waveform distortion for 525-line systems is measured with the field bar of the window signal shown in Fig. 6b. The use of the window signal must be noted in the measurement results.

*Note* – In Canada and the USA, field-time waveform distortion is normally measured as the peak-to-peak level variation over the whole of the bar top, excluding the first and last 250  $\mu$ s.

###### C.3.5.1.3 *Line-time waveform distortion*

Line-time waveform distortion is measured with element *B3* (Fig. 7) for 625-line systems and *B3* or *B2* (Fig. 8) for 525-line systems. The magnitude of the top distortion is obtained from the maximum departure in the level of the bar top from the level at the centre of the bar, expressed as a percentage of the bar amplitude as its centre. The first and last 1  $\mu$ s are neglected in this measurement.

*Note* – In Canada and the USA, line-time waveform distortion is normally measured as the peak-to-peak level variation over the whole of the bar top, excluding the first and last 1  $\mu$ s.

The magnitude of bottom distortion (base-line distortion) is obtained from the difference between the level at the point:

- 400 ns for 625-line systems
- 500 ns for 525-line systems

after the half amplitude point of the trailing edge of the bar and the level at a point which follows the bar by an interval equal to half the duration of the bar, and is expressed as a percentage of the bar amplitude. The distortion is to be measured after the bandwidth of the signal has been limited. Limitation may be achieved by the use of a network, the design of which is based on “Solution 3” in [Thomson, 1952], having its first zero at 3.3 MHz, or by an equivalent technique.

*Note* – Line time waveform distortion (measured at the top of the bar) and base line distortion are likely to be different, both in shape and magnitude.

#### C.3.5.1.4 *Short-time waveform distortion*

Short-time waveform distortion is measured with *B3* for 625-line systems and *B3* or *B2* for 525-line systems and the sine-squared pulse test signal element *B1* shown in Figs. 7 and 8. Two measurements of distortion can be made with these signals. The first consists of expressing the amplitude of the pulse as a percentage of the amplitude of the line time bar (element *B2* or *B3* in Figs. 7 and 8, as appropriate). The second consists of expressing the amplitude of the lobes, lagging or leading the pulse or bar as a time-weighted percentage of the amplitude of the received pulse or bar respectively.

The results of the foregoing measurements using the sine-squared pulse can be expressed in a compact form in terms of the *K*-rating method which is briefly described in Annex IV to Part C. In this method, equal *K*-values for the different parameters approximately correspond to equal degrees of subjective impairment. Measurements of the bar-edge response of 525-line systems can be expressed in terms of the *S*-rating which is a more recent method, based on broadly similar principles.

#### C.3.5.2 *Chrominance waveform distortion*

Experience suggests that this form of distortion need not be measured because circuits meeting the requirements for the other parameters in Part D have negligible chrominance waveform distortion.

#### C.3.5.3 *Chrominance-luminance inequalities*

##### C.3.5.3.1 *Gain inequality*

Chrominance-luminance gain inequality can be measured with the luminance bar *B2* and the elements *G*, *G1* and *G2*. Alternatively, the chrominance component of the composite pulse *F* may be used. The magnitude of the distortion is obtained from the departure in peak-to-peak amplitude of the modulated sub-carrier in *G1*, in *F*, in the last step of *G* or *G2*, from the amplitude of the luminance bar *B2*, expressed as a percentage of the latter. Account must be taken of the relative amplitudes of *B2* and *G* in the original signal for the 525-line case.

A further alternative is to compare the chrominance component of signal *F* with its luminance component.

##### C.3.5.3.2 *Delay inequality*

Chrominance-luminance delay inequality is measured on the composite pulse element *F*. It is expressed in ns, the value being positive when the chrominance element lags the luminance.

#### C.3.5.4 *Steady state characteristics*

##### C.3.5.4.1 *Gain*

The gain/frequency characteristic is measured by means of a sweep-frequency method or with the multi-burst test signal *C* shown in Figs. 9 and 10.

##### C.3.5.4.2 *Delay*

The delay/frequency characteristic is measured by means of a group-delay measuring set.



## REFERENCES

THOMSON, W. E. [1952] The synthesis of a network to have a sine-squared impulse response. *Proc. IEE*, Part III, **99**, 373.

*CCIR Documents*

[1970-74]: **a.** CMTT/207 (Italy); **b.** CMTT/210 (Italy); **c.** CMTT/188 (Germany (Federal Republic of)); **d.** CMTT/189 (Germany (Federal Republic of)).

## ANNEX I TO PART C

### TEST SIGNAL ELEMENTS

An indication of the signal elements required to carry out the tests mentioned in this Recommendation is given below in the form of figures. Preferred assemblies for insertion test signals are given in Recommendation 473. The preferred assemblies of elements for full-field measurements is the subject for further study. The reference designations used to describe these elements (e.g. signal *B1*) are the same as the reference designations in Recommendation 473. This Recommendation also contains full specifications of the test signal elements, with the exception of signals *A*, *B3* and the window (Fig. 6b).

*Note 1* – In the case of PAL and NTSC transmissions, the chrominance sub-carrier of test signal elements should be locked at the phase listed in Table I, where each phase angle is described with reference to the positive (*B-Y*) axis.

*Note 2* – For measurements requiring a change in average picture level (APL), test signals repeating a pattern composed of one line with assemblies of test signal elements followed by three or four consecutive flat lines (e.g. full white, half white, black) should be used. The signal sequence in each field should start at line 24 and 337 in the 625-line system, line 22 and 285 in the NTSC system and line 19 and 282 in the M/PAL system.

TABLE I

System	PAL	M/PAL <sup>(1)</sup>	NTSC
Element			
<i>D2</i>	$60 \pm 5^\circ$	$180 \pm 1^\circ$	$180 \pm 1^\circ$
<i>F</i>	$60 \pm 5^\circ$	$180 \pm 1^\circ$	Not defined
<i>G</i>	$60 \pm 5^\circ$	$180 \pm 1^\circ$	$90 \pm 1^\circ$

<sup>(1)</sup> Refer to Report 624 for system characteristics.

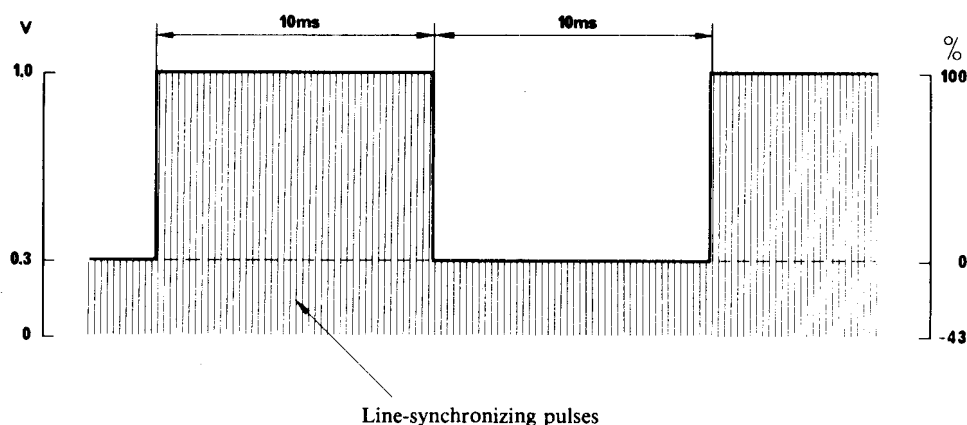

**FIGURE 5 – Signal A for 625-line systems**

*Note* – This signal may contain field-synchronizing pulses.

d06-sc

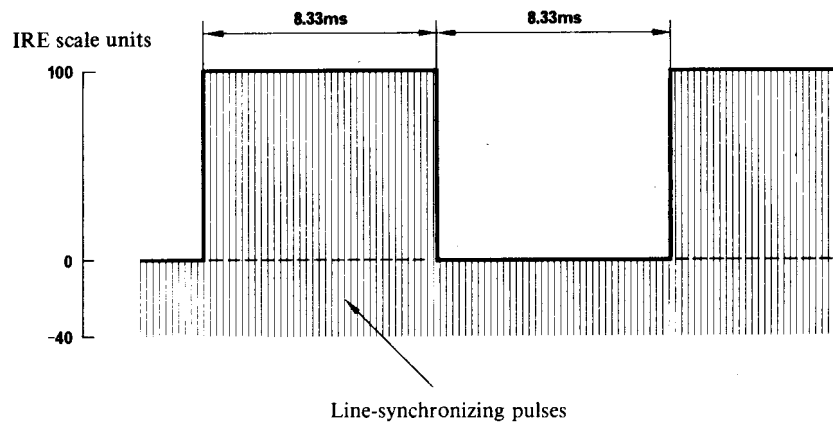

FIGURE 6a – Signal A for 525-line systems

Note – This signal may contain field-synchronizing pulses.

d07-sc

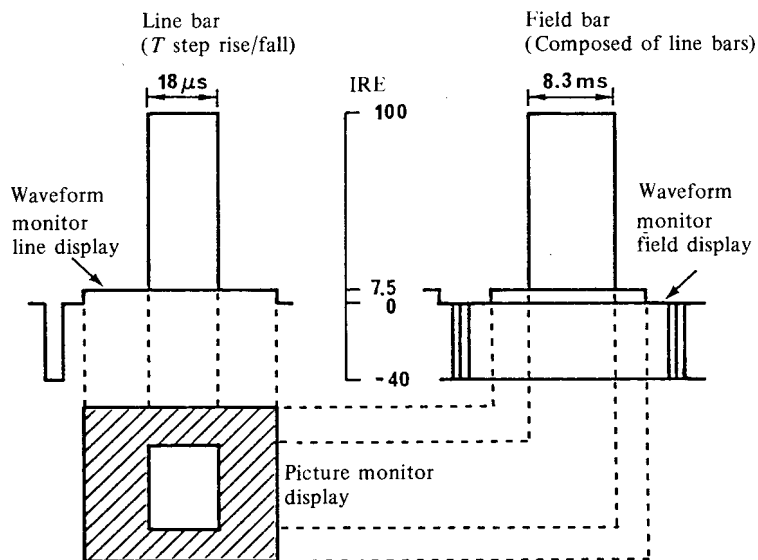

FIGURE 6b – The window signal for 525-line systems

d08-sc

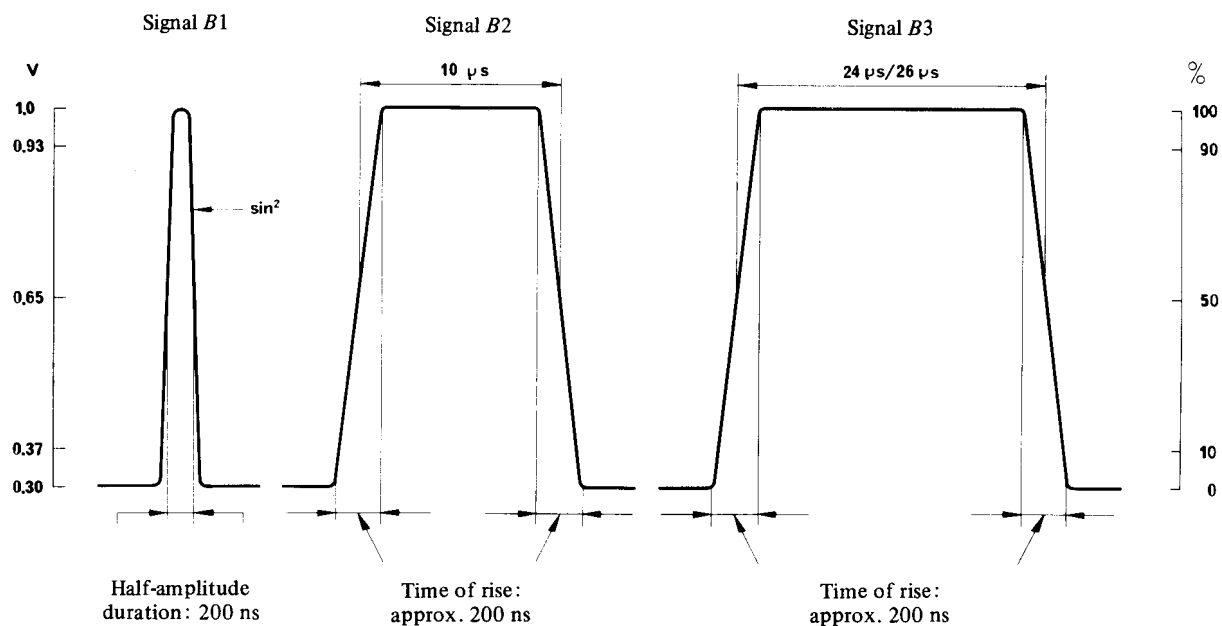

FIGURE 7 – Signal B for 625-line systems

Note 1 – In some OIRT countries, a half-amplitude duration of 160 ns is used for B1 and a time of rise of 80 ns for B2.

Note 2 – In France, the normal time of rise of B2 and B3 is approximately 110 ns.

d09-sc

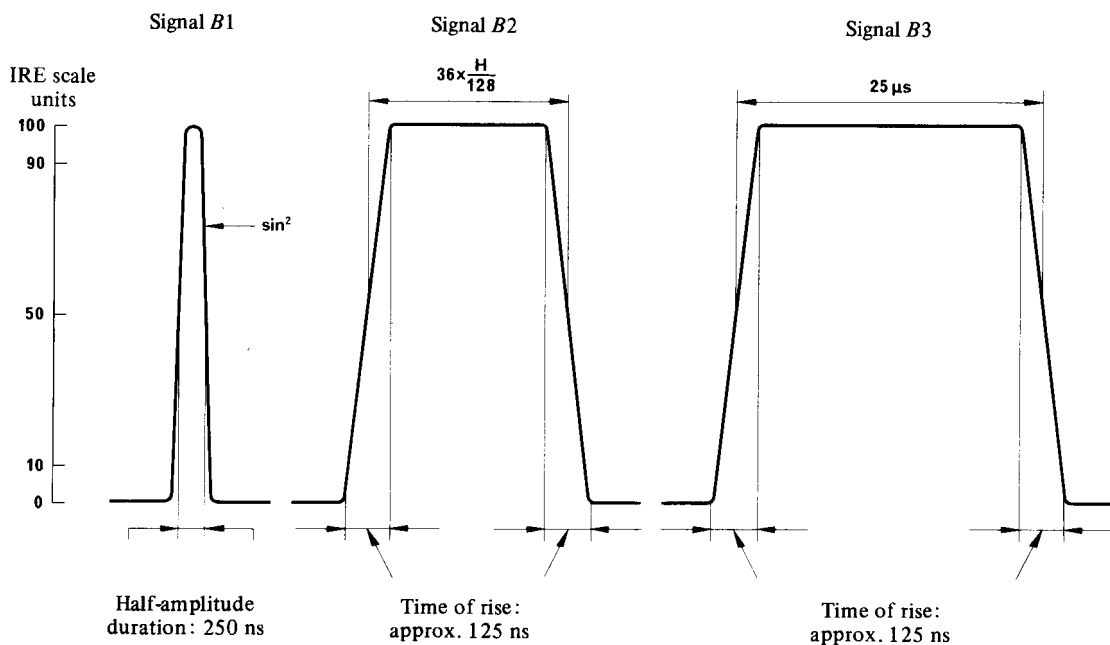

FIGURE 8 – Signal B for 525-line systems

d10-sc

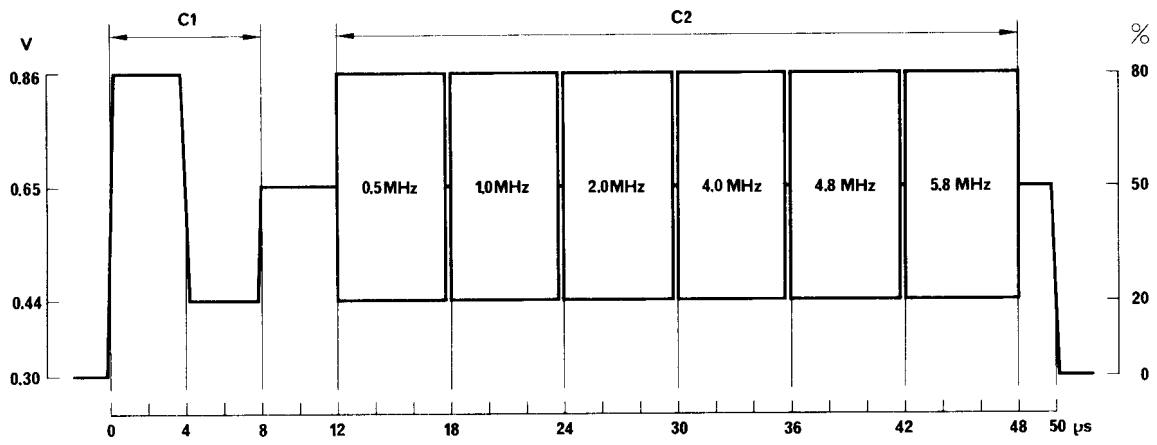

FIGURE 9 – Signal C for 625-line systems

Note – Some OIRT countries use 1.5 MHz and 2.8 MHz for the 2nd and 3rd bursts.

d11-sc

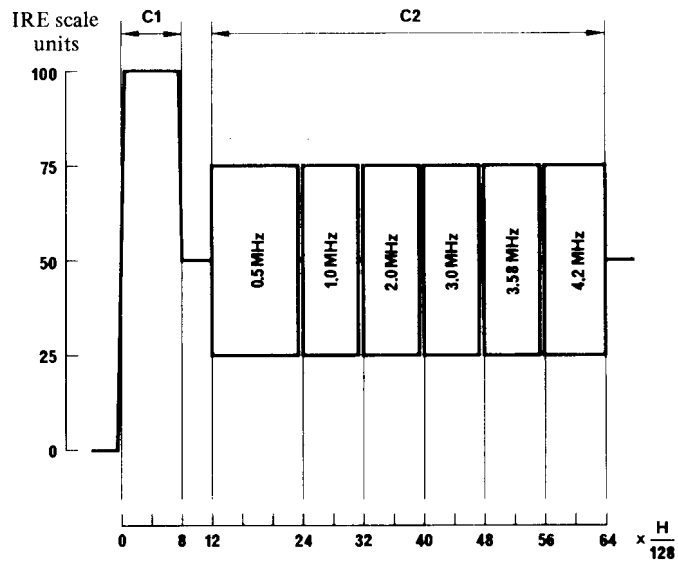

FIGURE 10 – Signal C for 525-line systems

d12-sc

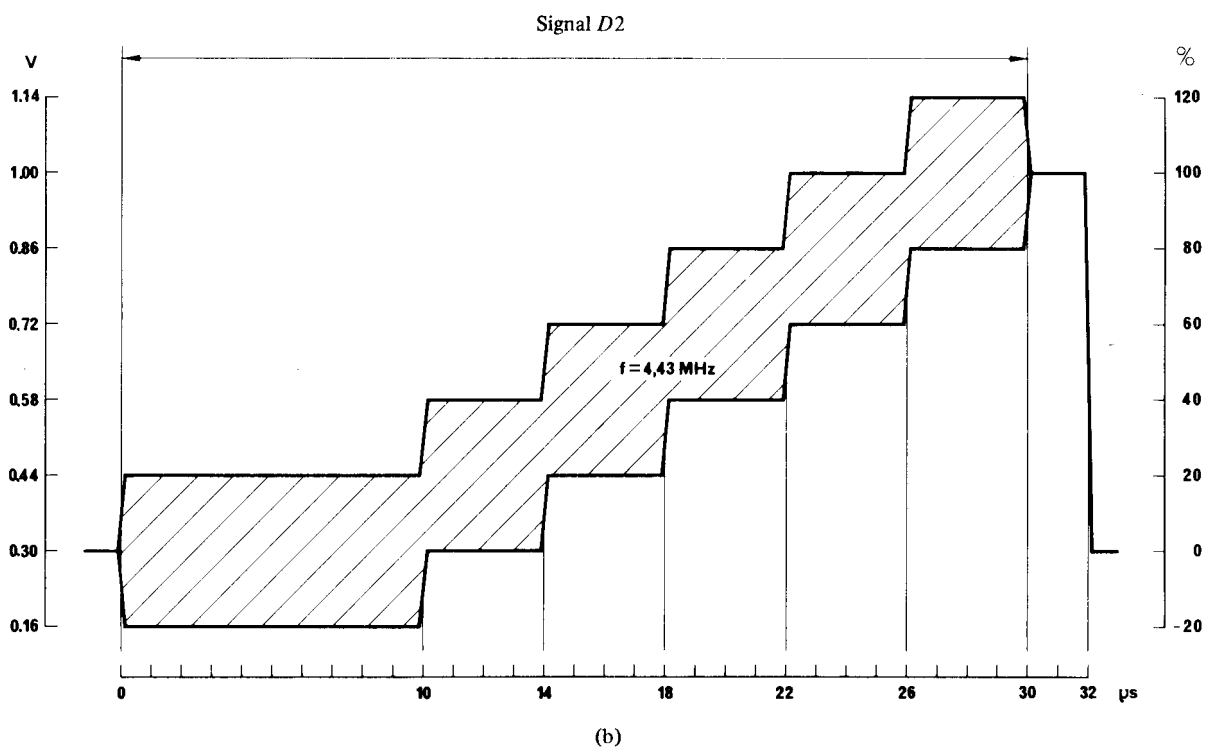
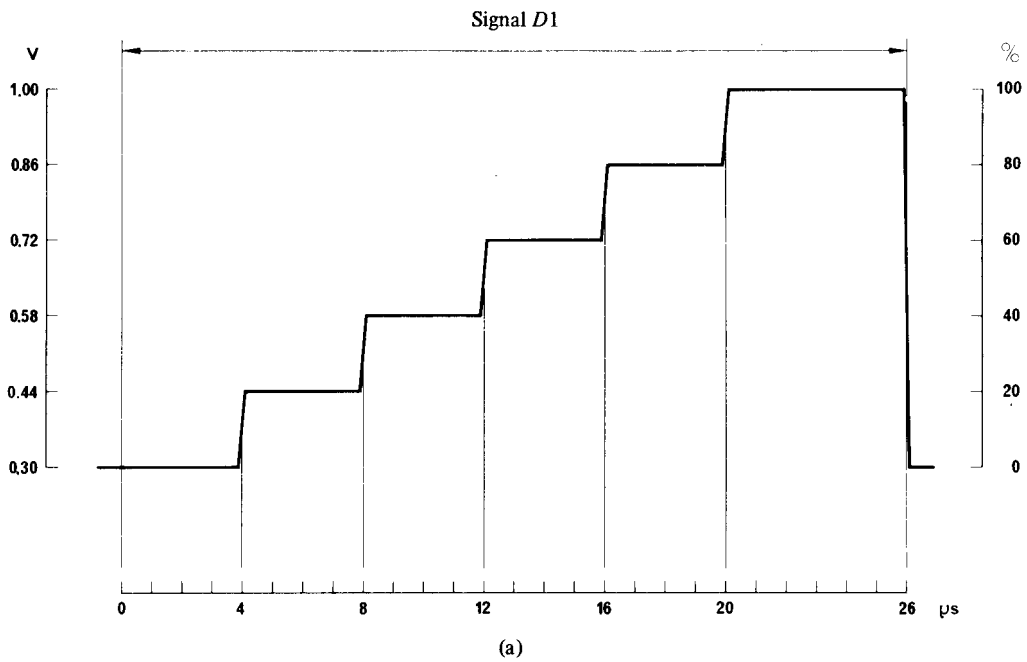

FIGURE 11 – Signal D for 625-line systems

Note – In full-field test signals, each tread of the staircase may have a duration of 8.66 μs.

d13-sc

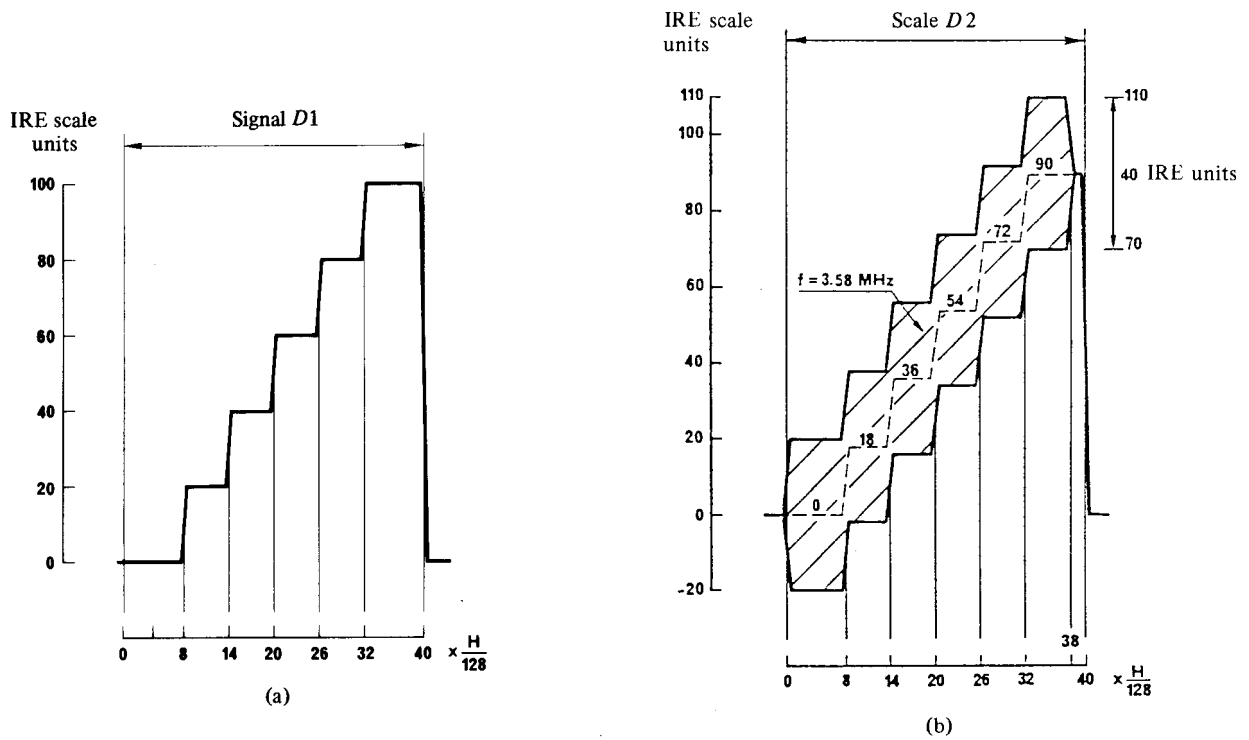

FIGURE 12 – Signal D for 525-line systems

Note 1 – Vertical scales give signal amplitudes. In Fig. 12b, the tread levels (in IRE units) are indicated on the dashed line.

Note 2 – Sub-carrier amplitude is  $\pm 20$  IRE units.

d14-sc

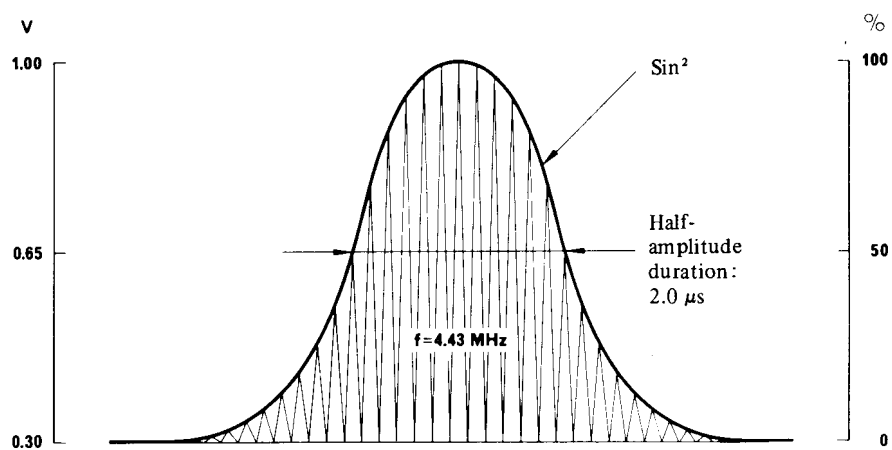

FIGURE 13 – Signal F for 625-line systems.

d15-sc

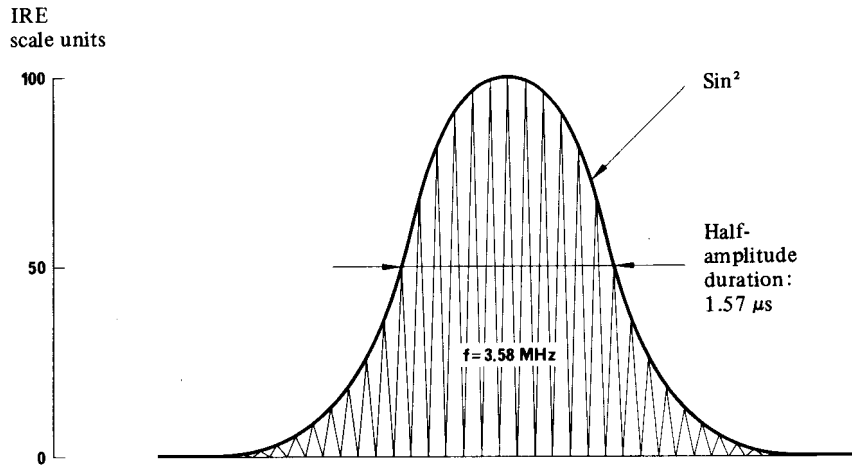

FIGURE 14 – Signal F for 525-line systems

d16-sc

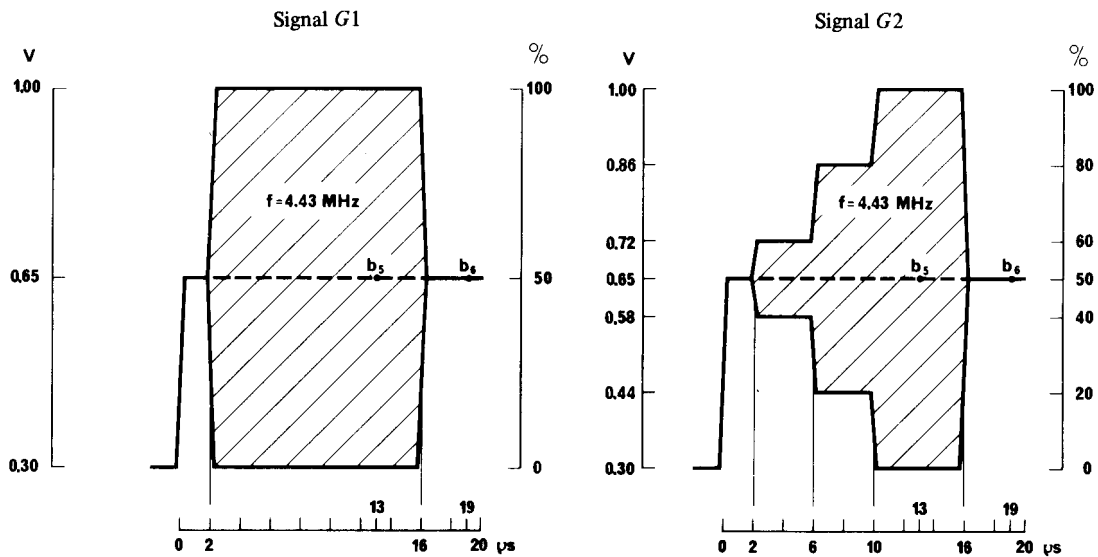

FIGURE 15 – Signal G for 625-line systems

d17-sc

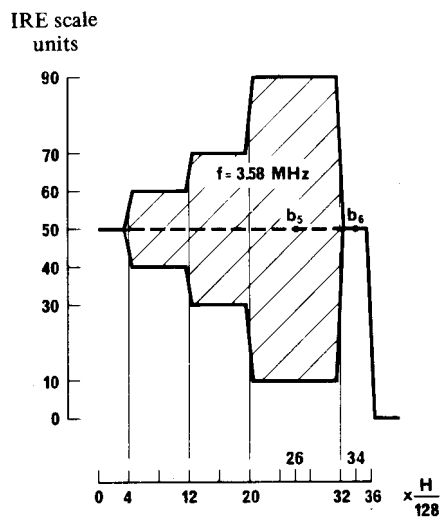

FIGURE 16 – Signal G for 525-line systems

## DESIGN OF FILTERS USED FOR MEASUREMENTS

## 1. Low-pass filter for use in noise measurements

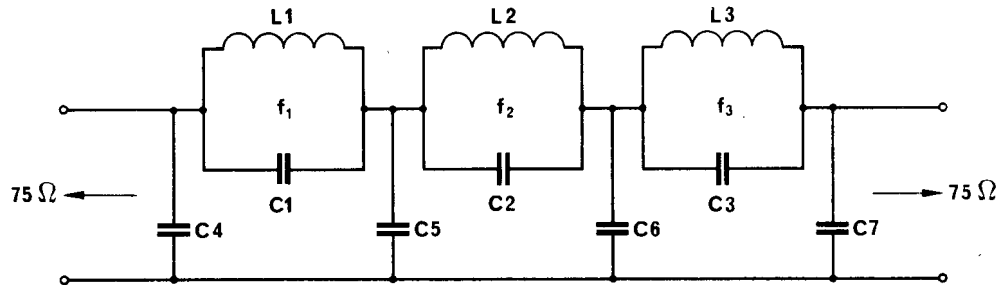

FIGURE 17 -- Low-pass filter diagram

d19-sc

TABLE OF VALUES

Component	Multistandard value ( $f_c = 5$ MHz)	Tolerance
C1	100	Note 2
C2	545	
C3	390	
C4	428	
C5	563	
C6	463	
C7	259	
L1	2.88	Note 3
L2	1.54	
L3	1.72	
$f_1$	9.408	
$f_2$	5.506	
$f_3$	6.145	

Note 1 – Inductances are given in  $\mu\text{H}$ , capacitances in pF, frequencies in MHz.

Note 2 – Each capacitance quoted is the total value, including all relevant stray capacitances, and should be correct to  $\pm 2\%$ .

Note 3 – Each inductor should be adjusted to make the insertion loss a maximum at the appropriate indicated frequency.

Note 4 – The  $Q$ -factor of each inductor measured at 5 MHz should be between 80 and 125.



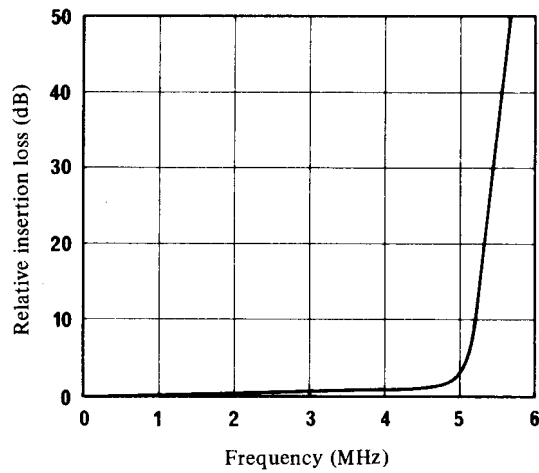

FIGURE 18 – Low-pass filter characteristic  
d20-sc

2. Combined high-pass, low-pass filter ( $f_c = 10$  kHz)

The high-pass section is used in series with the low-pass filter described in § 1 for measuring continuous random noise.

The low-pass section is used to measure power-supply hum.

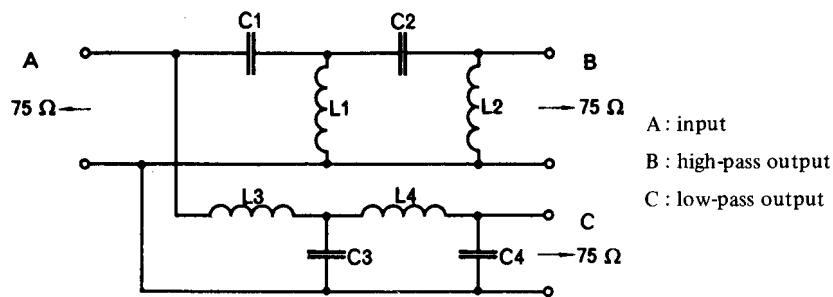

FIGURE 19 – Combined filter design diagram

d21-sc

TABLE OF VALUES

Component	Value	Tolerance
C1	139 000	± 5%
C2	196 000	
C3	335 000	
C4	81 200	
L1	0.757	± 2%
L2	3.12	
L3	1.83	
L4	1.29	

Note 1 – Inductances are given in mH, capacitances in pF.

Note 2 – The  $Q$ -factor of each inductor should be equal to, or greater than, 100 at 10 kHz.

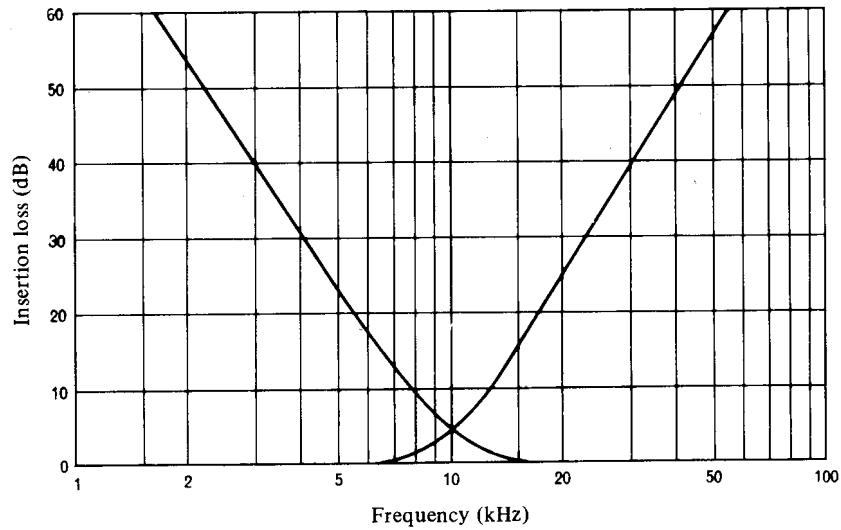

FIGURE 20 – Combined filter characteristic

d22-sc

### 3. Unified weighting network for random noise

#### 3.1 Network configuration

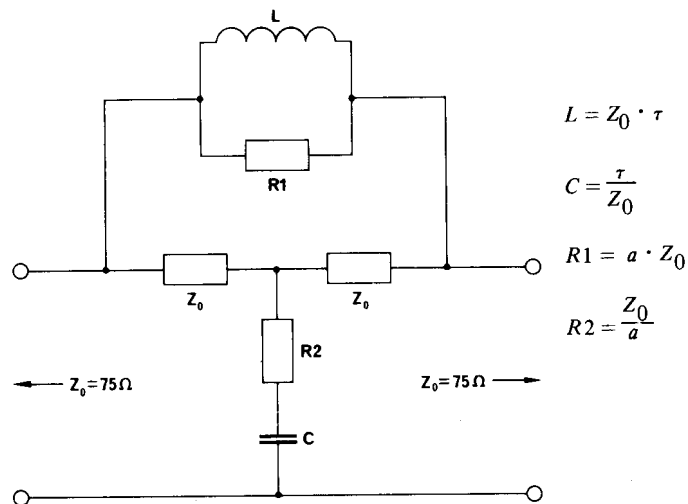

FIGURE 21 – Network diagram

d23-sc

#### 3.2 Insertion loss A

$$A = 10 \log \frac{1 + \left[ \left( 1 + \frac{1}{a} \right) \omega \tau \right]^2}{1 + \left[ \frac{1}{a} \omega \tau \right]^2} \text{ dB}$$

at high frequencies:  $A_\infty \rightarrow 20 \log (1 + a)$

where:

$$\tau = 245 \text{ ns}; a = 4.5 \quad (A_\infty \rightarrow 14.8 \text{ dB})$$

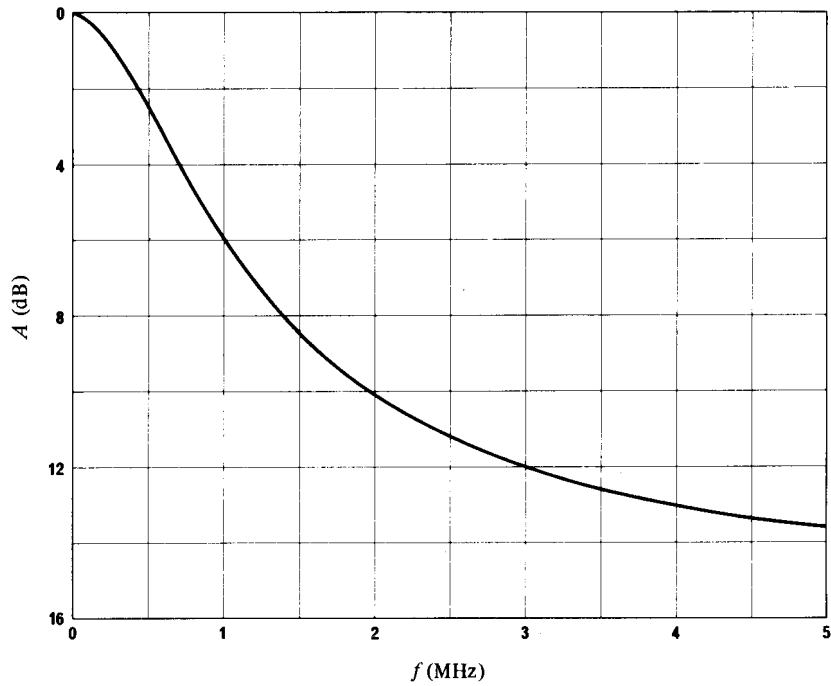

FIGURE 22 – Unified weighting characteristic

d24-sc

3.3 Noise weighting factors in a 5 MHz band

Flat noise: 7.4 dB

Triangular noise: 12.2 dB

4. Examples of differentiating and shaping network for luminance non-linearity measurement

Note that the networks shown below have equivalent transfer characteristics.

4.1 Non-constant resistance form

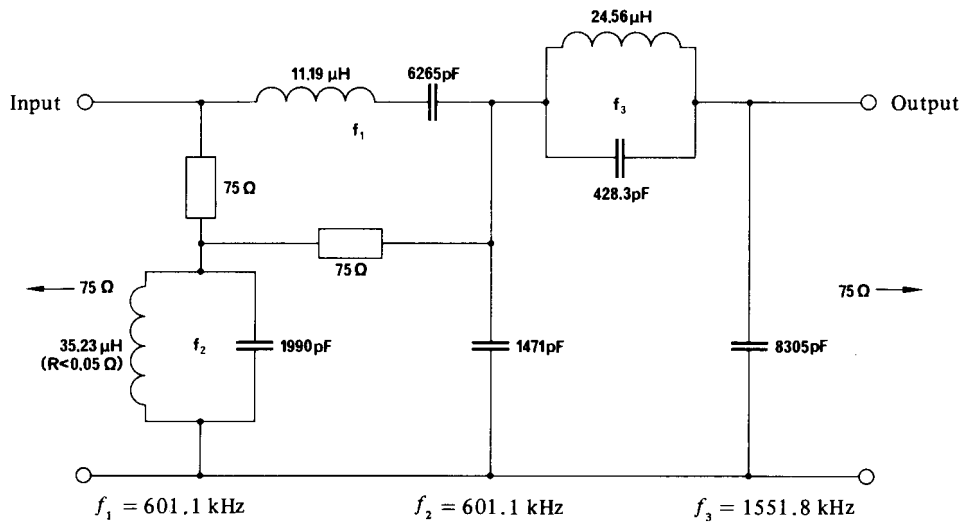

FIGURE 23 – Non-constant resistance network diagram

Note 1 – Capacitor and resistor tolerances  $\pm 1\%$ .

Note 2 – Each inductor should be adjusted to resonate at the appropriate indicated frequency.

Note 3 – This network requires to be operated between  $75 \Omega$  terminations for correct performance.

d25-sc

4.2 Constant resistance form

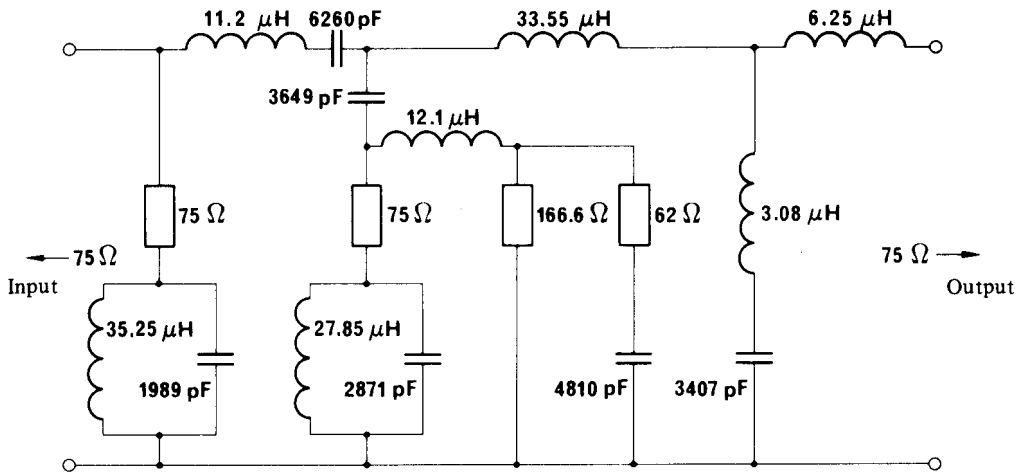

FIGURE 24 – Constant resistance network diagram

Note – Capacitor and inductor tolerances ±2%, resistor tolerance ±1%. The *Q*-factor of each inductor should be equal to, or greater than, 80 at 1 MHz.

d26-sc

4.3 Step response of staircase differentiating network

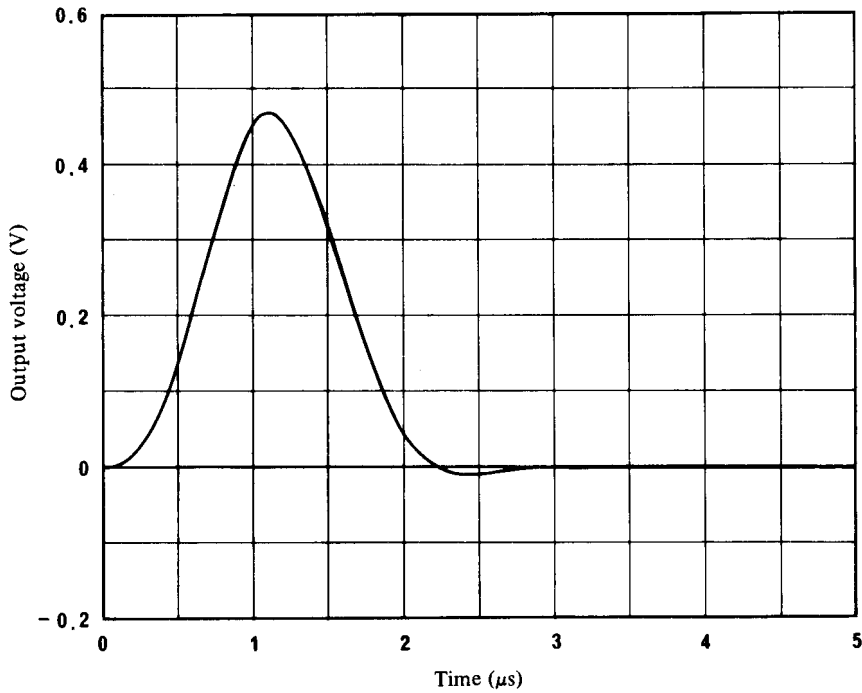

FIGURE 25 – Transient response of the network

d27-sc

5. Thomson filter for use in measurement of line-time waveform distortion

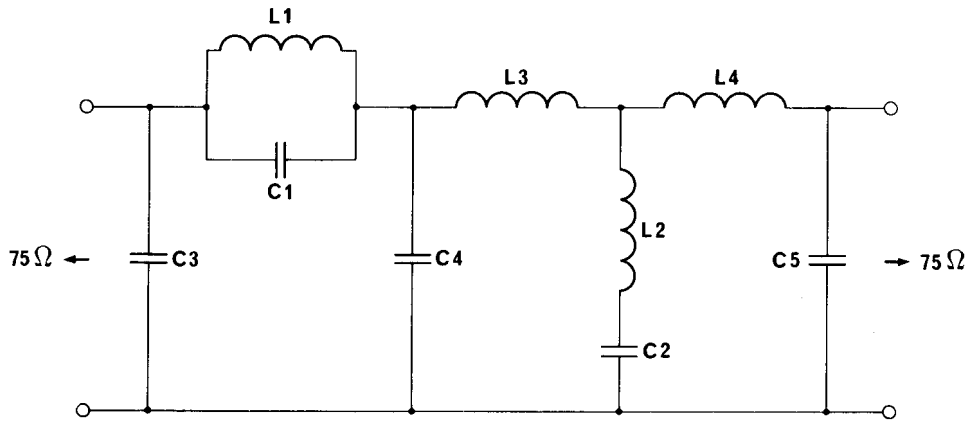

FIGURE 26 – Thomson filter diagram

d28-sc

TABLE OF VALUES

Component	Value ( $f_{\infty} = 3.3 \text{ MHz}$ )
C1	147.7
C2	4044
C3	141.6
C4	1057
C5	310.5
L1	2.948
L2	0.5752
L3	5.767
L4	5.664

Note 1 –  $f_{\infty}$  is the frequency of the first zero of the output/input transfer function.

Note 2 – Inductances are given in  $\mu\text{H}$ , capacitances in pF.

Note 3 – For further details see MacDiarmid and Phillips, *Proc. IEE*, Vol. 105B, 440.

ANNEX III TO PART C

METHODS OF MEASUREMENT USING INSERTION TEST SIGNALS

1. Introduction

The international insertion test signals (ITS) are described in Recommendation 473. They may be used for out-of-service checks to give results that are closely related to the methods given in the body of this Recommendation or for in-service checks.

Such measurements may give results which differ from those obtained with full-field test signals because:

- the test signal elements may not be identical with those used for full-field tests or their arrangement may be different;
- the measurement result may depend upon the content of the preceding line(s);
- the average picture level (APL) depends upon the nature of the programme signal;
- measurements made on the basis of a single test-line per field may not be fully representative of the performance of any circuit in which half-field-rate dispersal is employed (e.g. in satellite circuits).

To reduce changes in the measurement results due to errors affecting one or several lines it is desirable for the line preceding the test-line(s) to carry a signal having a mean-level of approximately 50%. Such a signal may be a line-bar at 50% of white level or a data signal waveform having a mean-level of approximately 50%.

When measurements with insertion test signals are effected outside programme transmission periods they should be associated with the normal low, mean and high values of average picture level.

Because the methods of measurement specified in Recommendation 569 may in some cases differ from those of this Annex, measurements made by automatic measuring equipment may give results which differ from those obtained normally in accordance with this Annex.

## 2. Measurement methods

The references given in brackets below refer to the section numbering of Part C.

### 2.1 *Measurements which are different with insertion test signals*

#### *Insertion gain (§ C.3.1) – Luminance bar amplitude*

The signal element used is the luminance bar (B2) in line 17.

The amplitude  $L$  of the luminance bar is defined as the difference in level between the mid-point of the luminance bar ( $b_2$  in Figs. 27 and 28) and a specified reference point ( $b_1$  in Figs. 27 and 28).

#### *Continuous random noise (§ C.3.2.1)*

Measurements are made using either a specified line, which is effaced at the insertion point (lines 22 and 335 for 625-line signals) or on the top of the luminance bar.

Band limiting and noise weighting are specified in § C.3.2.1. In some cases, the measuring instrument may have to be preceded by alternative band limiting filters, for example, when sampling techniques are used and low frequency energy is transferred into the band to be measured. Another problem is described in [CCIR, 1974-78] which also requires different band limiting filters. In such cases upper limiting shall be done by the filter according to § 1 of Annex II to Part C of this Recommendation. Lower limiting shall be done by a first order 200 kHz high-pass filter with a slope of 20 dB per decade. The lower band limit is such that power supply hum, microphonic noise and pulses of line frequency are excluded. The upper limit is so selected as to eliminate noise which occurs outside the wanted band of the video signal.

*Note* – Table I of Recommendation 569 shows the effects of using a 200 kHz high-pass filter on the measurement of continuous random noise.

#### *Luminance non-linearity (§ C.3.4.1.1)*

§ 3.4.1.1 of Part C applies, except that the test signal element used for 525-line colour transmissions may be D2.

#### *Line-time waveform distortion (§ C.3.5.1.3)*

The signal element used is the luminance bar (B2) in line 17.

The magnitude of the bar-top distortion is the maximum departure in the level in the interval between  $b_4$  and  $b_3$  (Figs. 27 and 28) expressed as a percentage of the bar amplitude.

As shown in Figs. 27 and 28 the first and the last 1  $\mu$ s are neglected in this measurement.

The magnitude of the base-line distortion is obtained from the difference between the level at the point:

- 400 ns for 625-line systems,
- 500 ns for 525-line systems,

after the half-amplitude point of the trailing edge of the luminance bar and the level at the reference point ( $b_1$  in Figs. 27 and 28) expressed as a percentage of the luminance bar amplitude.

The distortion is to be measured after bandwidth limitation as in § C.3.5.1.3.

2.2 *Measurements which are, in principle, the same with insertion test signals*

The following measurements take the luminance-bar amplitude, as defined in § 2.1 above, as the reference level:

- chrominance-luminance intermodulation (§ C.3.4.1.4);
- short-time waveform distortion. (The reference point for the pulse amplitude is also  $b_1$  in Figs. 27 and 28) (§ C.3.5.1.4);
- chrominance-luminance gain inequality (§ C.3.5.3.1).

2.3 *Measurements which are identical with insertion test signals*

- return loss (§ C.2.2);
- cross-talk from another television channel (§ C.3.3);
- chrominance non-linearity (§ C.3.4.1.2);
- differential gain and differential phase (§ C.3.4.1.3);
- synchronizing signal amplitude (§ C.3.4.2);
- chrominance waveform distortion (§ C.3.5.2);
- chrominance-luminance delay inequality (§ C.3.5.3.2);
- steady-state gain/frequency characteristic (§ C.3.5.4.1).

2.4 *Measurements which are impracticable with insertion test signals*

- non-useful d.c. component (§ C.2.3);
- periodic noise (§ C.3.2.2);
- impulsive noise (§ C.3.2.3);
- long-time waveform distortion (§ C.3.5.1.1);
- field-time waveform distortion (§ C.3.5.1.2);
- steady state delay/frequency characteristic (§ C.3.5.4.2).

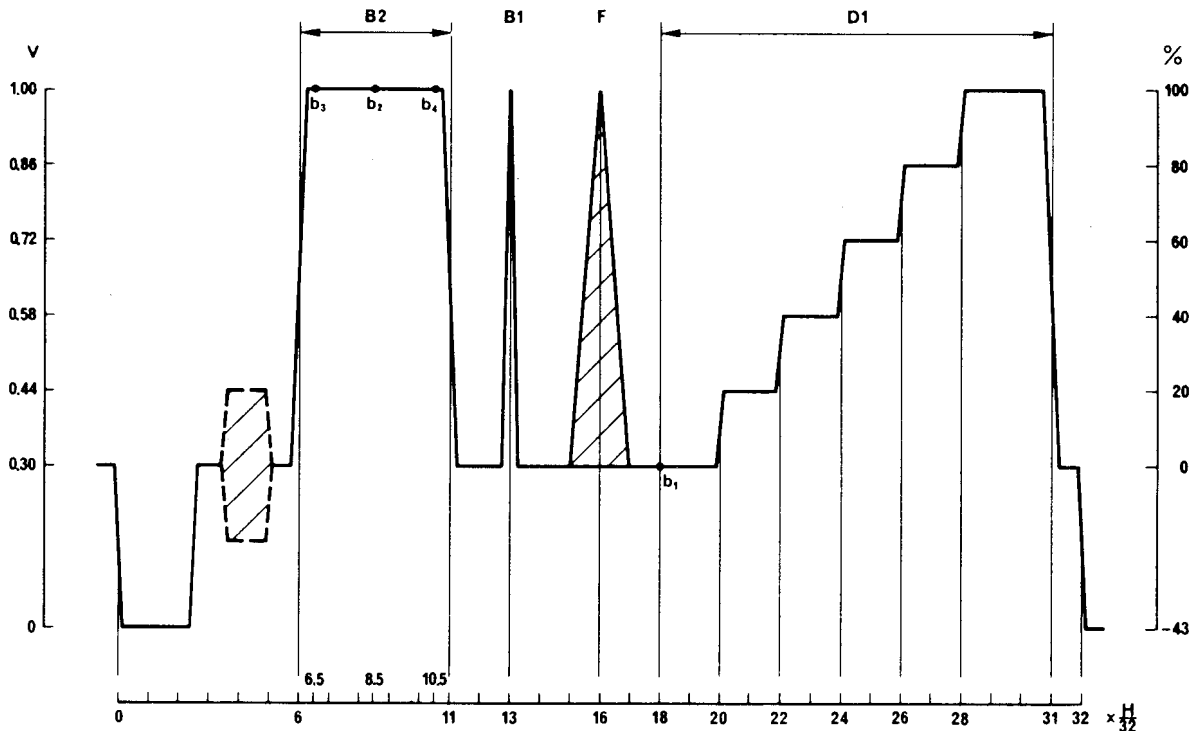

FIGURE 27 – Line 17 for 625-line systems

d29-sc

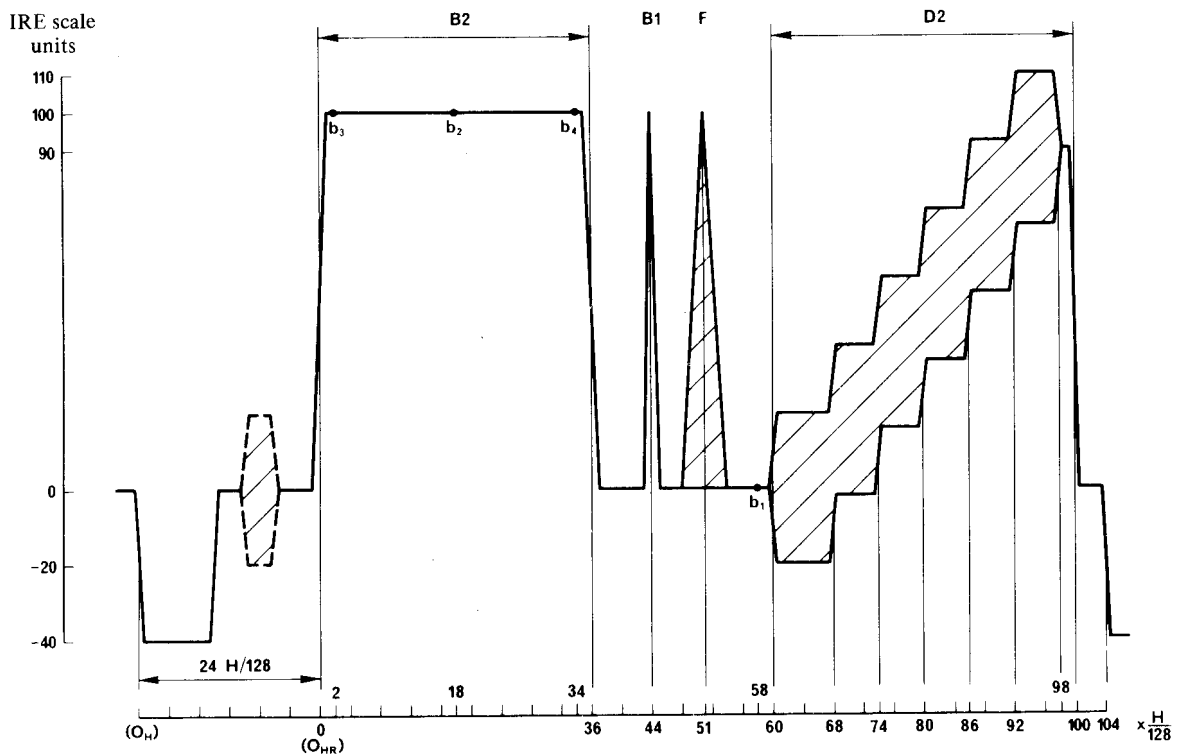

FIGURE 28 – Line 17/field 1 for 525-line systems

d30-sc

## REFERENCES

### CCIR Documents

[1974-78]: CMTT/246 (Germany (Federal Republic of)).

## BIBLIOGRAPHY

### CCIR Documents

[1974-78]: CMTT/36 (United Kingdom); CMTT/57 (European Broadcasting Union); CMTT/59 (European Broadcasting Union); CMTT/76 (Germany (Federal Republic of)); CMTT/77 (Germany (Federal Republic of)).

## ANNEX IV TO PART C

### SHORT-TIME WAVEFORM DISTORTION – THE *K*-RATING METHOD OF ASSESSMENT

#### 1. Introduction

This Annex briefly describes the *K*-rating method of assessment of short-time waveform distortion which provides a compact method of expressing the results of the measurements outlined in § C.3.5.1.4. It is based on a deleted Recommendation (Annex II to Recommendation 451, Geneva, 1974) which in turn was based on published papers by [Lewis, 1954] and [MacDiarmid, 1959]. A more recent method, called *S*-rating, for assessing measurements of the bar-edge response on 525-line systems in a broadly similar manner, has been described [Siocos and Chouinard, 1979].

The *K*-rating method, as originally described, was in fact two methods ideally giving the same results:

- the routine-test method, and
- the acceptance-test method.



The routine-test method is based on parameters which can easily be measured on an oscilloscope to give results quickly. The acceptance-test method, based on the response to a  $T$  sine-squared pulse, is more rigorous and well suited to the analysis of systems and networks in addition to acceptance tests on hardware. The rating method has been devised so that equal  $K$ -values obtained for the various parameters correspond approximately to equal subjective impairments on pictures.

Section 2 shows how the performance objectives and tolerances for short-time waveform distortion can be expressed using the routine-test  $K$ -rating method. Section 3, for completeness, outlines how the acceptance-test method could be used.

## 2. Routine-test method

For the first two parameters, the response to the  $2T$  sine-squared pulse ( $B1$ ) and one of the bar elements ( $B2$  or  $B3$ ) are used. The third parameter is not normally measured on circuits and equipments for the transmission of composite colour signals. It is included here for possible future use on circuits for colour signals in analogue component form. The test-signal element required is a  $T$  sine-squared pulse, where  $T = 1/2F_c$  ( $F_c$  is the nominal bandwidth of the channel-under-test).

### 2.1 $2T$ pulse response

For a particular value of  $K_{(2T)}$ , a mask of the type shown in Figs. 29a or 29b is required. The tolerances on the response at the time intervals shown in Fig. 29a correspond to  $\pm 4K$  at  $\pm 200$  ns,  $\pm 2K$  at  $\pm 400$  ns and  $\pm K$  at  $\pm 800$  ns and beyond, with the same values at the greater times in Fig. 29b.

For the masks illustrated in Figs. 29a and 29b:

$$K_{(2T)} = 3\%$$

### 2.2 $2T$ pulse/bar ratio

The  $2T$  pulse/bar ratio ( $P/B$ ) is related to  $K_{(P/B)}$  by:

$$K_{(P/B)} = \frac{1}{4} \left| \frac{B}{P} - 1 \right| \times 100\%$$

### 2.3 $T$ pulse response

This measurement is not necessary when the circuit has to meet the close tolerances on chrominance-luminance gain and delay inequalities required for composite colour signals. In other cases, the tests using only the  $2T$  pulse leave distortions in the upper half of the transmission band virtually untested, so that a test using the  $T$  pulse becomes necessary.

Limits to the response to the  $T$  pulse cannot be specified rigidly because the spectrum of the  $T$  pulse extends far beyond the nominal upper frequency limit of the circuit, and the response must therefore contain irrelevant information. A partial solution has been found by the insertion of a phase-corrected low-pass filter with a sharp cut-off at the edge of the nominal channel band, between the channel under test and the oscilloscope. The filter is first measured using a local test signal. The pulse-to-bar ratio is then, say  $y$  ( $y$  will be in the region of 0.82). The channel under test is then connected to the filter and the pulse-to-bar ratio measured. From this, the  $T$ -pulse rating is, approximately:

$$K_{(T)} = \frac{1}{4} \left| y \cdot \frac{B}{P} - 1 \right|$$

Delay errors near the edge of the channel pass-band can also affect the  $T$ -pulse  $K$ -rating. An estimate of the effects of such errors can be obtained from the change, caused by the channel, in the first pre- and post-overshoots measured at the filter output. The change in overshoot (normalized to the pulse amplitude) is, approximately,  $3K_{(T)}$ .

### 3. Acceptance-test method

From the measured  $T$ -pulse response and the measured or assumed response of the measuring equipment itself, the “filtered impulse response” is derived and expressed in the form of a normalized time series [Lewis, 1954]. The “main” term of this series represents the ideal or non-distorting part, and the “echo” terms represent the distorting parts. The amplitudes of the echo terms should meet the following four sets of limits giving four values of  $K$ .

Let the time series representing the filtered impulse response be:

$$B(rT) = \dots B_{-r}, \dots B_{-1}, B_0, B_{+1}, \dots B_{+r}, \dots$$

and assume that this has already been normalized so that  $B_0 = 1$ ; let the serial product of  $B(rT)$  and the series  $[1/2, 1, 1/2]$  be

$$C(rT) = \dots C_{-r}, \dots C_{-1}, C_0, C_{+1}, \dots C_{+r}, \dots$$

where:

$$C_r = \frac{1}{2}B_{r-1} + B_r + \frac{1}{2}B_{r+1}$$

then:

$$K1 \geq \frac{1}{8} \left| r \cdot \frac{C_r}{C_0} \right| \quad \text{for } -8 \leq r \leq -2 \quad \text{and} \quad +2 \leq r \leq +8$$

$$K1 \geq \left| \frac{C_r}{C_0} \right| \quad \text{for } r \leq -8 \quad \text{and} \quad r \geq +8$$

and:

$$K2 = \frac{1}{4} \left| \left( \frac{1}{C_0} \sum_{-8}^{+8} B_r \right) - 1 \right|$$

$$K3 = \frac{1}{6} \left| \left( \sum_{-8}^{+8} B_r \right) - 1 \right|$$

$$K4 = \frac{1}{20} \left\{ \left( \sum_{-8}^{+8} |B_r| \right) - 1 \right\}$$

The series  $C(rT)$  represents fairly closely the response to a  $2T$  pulse.  $K1$  is thus approximately equivalent to  $K_{(2T)}$  in the routine test method.  $K2$  places limits on the  $2T$  pulse/bar ratio and is approximately equivalent to  $K_{(P/B)}$  in the routine-test method.  $K3$  places limits on the pulse/bar ratio of the response to a hypothetical pulse-and-bar test signal in which the pulse is an ideal filtered impulse and is approximately equivalent to  $K_{(T)}$  in the routine-test method.  $K4$  places an upper limit on the average amplitude, ignoring signs, of the 16 central echo terms, to protect against rarely-met distortions such as a long train of echoes whose magnitudes are not great enough individually to reach one of the other limits. It has no routine-test equivalent.

#### REFERENCES

- LEWIS, N. W. [1954] Waveform responses of television links. *Proc. IEE*, Vol. 101, Part III, 258-270.
- MACDIARMID, I. F. [1959] Waveform distortion in television links. *POOEJ*, Vol. 52, 108-114 and 188-195.
- SIOCOS, C. A. and CHOUINARD, G. [June, 1979] Subjective impairment units in relation with oscilloscope graticules for evaluating short-time linear waveform distortion of the luminance signal in 525-line television. *IEEE Trans. Broadcasting*, Vol. BC-25, 2, 63-71.

PART D – DESIGN OBJECTIVES AND TOLERANCES APPLICABLE  
TO HYPOTHETICAL REFERENCE CIRCUITS

## D.1 Introduction

The purpose of this Part is to provide design objectives and tolerances for the transmission performance characteristics described in § 2 and 3 of Part B. The design objectives and tolerances shown are applicable to circuits which are required to transmit 525- and/or 625-line television signals, these being either monochrome signals or colour signals coded in accordance with such systems as NTSC, PAL or SECAM, as described in Report 624. International circuits using equipment designed by the time this Recommendation is adopted may have characteristics different from those in this part.

Section numbering in this part is related to section numbers of Part B. Sections which are not necessarily relevant to monochrome transmission are D.3.4.1.2, D.3.4.1.3, D.3.4.1.4, D.3.5.2 and D.3.5.3.

This Recommendation does not contain any explicit definition of the bandwidth required for the transmission of colour television signals having at various times any of the standards defined in Report 624. As some of these standards require a bandwidth of 6 MHz, this is the only figure that can be considered to be fully satisfactory. However, because this bandwidth would cause considerable difficulty in countries using standards requiring appreciably smaller bandwidths, it is proposed that, for international circuits which may be required to transmit signals on any standard, it will be sufficient to define the performance of these circuits up to a frequency of 5.5 MHz, unless otherwise specified in the manner indicated in § D.3.5.4. It is noted, however, that countries using 6 MHz bandwidth may have to be protected from interference lying in the unspecified frequency band (from 5.5 to 6 MHz), which for them is in-band interference by means of a phase-corrected low-pass filter. An example of a suitable filter is given elsewhere [CCIR, 1970-74a].

## D.2 Objectives and tolerances at points of video interconnection

### D.2.1 *Nominal impedance*

At video interconnection points, the input and output impedance ( $Z_0$ ) of each section should be either unbalanced to earth with a nominal value of 75  $\Omega$  resistive, or balanced to earth with a nominal value of 124  $\Omega$  resistive.

### D.2.2 *Return loss*

At video interconnection points, the return loss, relative to  $Z_0$ , of a measured impedance  $Z$  should not be less than 30 dB.

### D.2.3 *Non-useful d.c. component*

At video interconnection points, any non-useful d.c. component should not exceed 2.75 V, when terminated in the nominal impedance, or 5.5 V in an open circuit.

### D.2.4 *Nominal signal amplitude*

The nominal peak-to-peak amplitude of the monochrome video signal ( $M$  in Fig. 3) is 1.0 V.

The nominal peak-to-peak amplitude of a composite colour video signal ( $H$  in Fig. 3) will depend upon the characteristics of the particular colour television system employed (see the equations given in Item 2.9 of Table II of Report 624), but for circuits required at various times to transmit all systems covered by that Report, a maximum value of 1.25 V should be assumed.

## D.3 Transmission performance objectives and tolerances

Tolerances proposed here are expected to apply for most of the time but may be exceeded for part of the time. Further study is required [CCIR, 1970-74b].

It is assumed that any earth stations in the circuit will be operating with a  $G/T$  ratio of no less than 40.7 dB and will be transmitting sound on a separate carrier. The tolerances do not necessarily apply to stations operating under different conditions.

### D.3.1 *Insertion gain*

The insertion gain, after initial or routine adjustment, should be  $0 \pm 0.5$  dB.

#### D.3.1.1 *Variations in the insertion gain*

Any variation of insertion gain with time should not exceed the following limits:

- short period variations (e.g. 1 s):  $\pm 0.3$  dB;
- medium period variations (e.g. 1 h):  $\pm 0.5$  dB.

### D.3.2 *Noise*

#### D.3.2.1 *Continuous random noise*

When the noise is band limited and weighted in accordance with Part C of this Recommendation, the signal-to-weighted-noise ratio should not fall below 53 dB for more than 1% of any month, nor below 45 dB for more than 0.1% of any month.

*Note 1* – Where colour television is concerned, noise measurements using the unified network can only be considered as giving a valid indication of the subjective impairment due to the noise in cases where the noise power per unit bandwidth at 5 MHz does not exceed that at 1 MHz by more than about 11 dB. This condition will be met in the majority of cases with existing transmission systems and only the recommended weighting network will be used for operational purposes. For new systems that would not meet this condition, designers should verify by other means that signal-to-weighted-noise ratio is satisfactory and that the recommended weighting network gives satisfactory results (see Recommendation 568).

*Note 2* – There may be administrations which need, for national purposes, values of signal-to-noise ratio which differ from 53 dB.

*Note 3* – At present satellite circuits may not be able to meet the performance objective for continuous random noise. Currently achievable values of signal-to-noise ratios are given in Report 965.

#### D.3.2.2 *Low-frequency noise*

It is not possible to give objectives for low-frequency noise at the present time. A signal-to-noise ratio of 43 dB has been suggested by one administration for System M. Contributions on this parameter are invited from other administrations.

#### D.3.2.3 *Periodic noise*

For power supply hum including lower-order harmonics, the signal-to-noise ratio should not be less than 35 dB. For single-frequency noise between 1 kHz and 5.5 MHz, the signal-to-noise ratio should not be less than 55 dB.

*Note* – Circuits which are only required to transmit 525-line signals need only be tested up to 4.2 MHz.

#### D.3.2.4 *Impulsive noise*

For impulsive noise of a sporadic or infrequently-occurring nature, the signal-to-noise ratio should not be less than 25 dB.

### D.3.3 *Cross-talk from another television channel*

If the cross-talk is substantially undistorted, the signal-to-cross-talk ratio should not be less than 58 dB. If the cross-talk is substantially “differentiated” (i.e. cross-talk voltage proportional to frequency), the signal-to-cross-talk ratio should not be less than 50 dB.

### D.3.4 *Non-linear distortion*

In this section the terms “low average picture level” and “high average picture level” are used. For low average picture level, either 10% or 12.5% is acceptable. For high average picture level, either 87.5% or 90% is acceptable.

The figures shown for a sending level of +3 dB are included only as a guide for designers and require further study. The question as to whether +3 dB is the optimum test signal level for use in specifying circuit overload performance also requires further study.

#### D.3.4.1 *Picture signal*

##### D.3.4.1.1 *Luminance signal*

On circuits designed for colour television transmission, the distortion should not exceed 5% at high or low average picture level. The figure applicable to a test signal sent at 3 dB above normal level is 10% at the same average picture levels. On circuits designed for monochrome television transmission only, these objectives should be 12% and 24% respectively.

##### D.3.4.1.2 *Chrominance signal*

For System M, the following figures apply:

*Chrominance gain non-linearity.* The distortion should not exceed 4% at high or low average picture level. In addition, when the signal is sent at 3 dB above the normal amplitude, the distortion should not exceed 8% at the same average picture levels.

*Chrominance phase non-linearity.* The distortion should not exceed 4° at high or low average picture level. In addition, when the signal is sent at 3 dB above the normal amplitude, the distortion should not exceed 8° at the same average picture levels.

Figures for other systems require further study.

##### D.3.4.1.3 *Intermodulation from the luminance signal into the chrominance signal*

###### *Differential gain*

Differential gain should not exceed the following figures at high or low average picture level:

For 3.58 MHz:  $x$  or  $y$  or  $x + y$  : 10%

For 4.43 MHz:  $x$  or  $y$  : 10%;  $x + y$  : 12%.

The figures applicable to a signal sent at +3 dB are double those shown above.

###### *Differential phase*

Differential phase should not exceed the following figures at high or low average picture level:

For 3.58 MHz:  $x$  or  $y$  or  $x + y$  : 5°

For 4.43 MHz:  $x$  or  $y$  : 5°;  $x + y$  : 6°.

The figures applicable to a signal sent at +3 dB are double those shown above.

##### D.3.4.1.4 *Intermodulation from the chrominance signal into the luminance signal*

The distortion should not exceed  $\pm 3\%$  at low or high average picture levels. The figure applicable to a test signal sent at 3 dB above normal amplitude is  $\pm 6\%$  at the same average picture levels.

#### D.3.4.2 *Synchronizing signal*

##### D.3.4.2.1 *Steady-state distortion*

The distortion should not exceed  $\pm 10\%$  at high or low average picture level. The figure applicable to a test signal sent at 3 dB above normal amplitude is  $\pm 20\%$  at the same average picture levels.

##### D.3.4.2.2 *Transient distortion*

It is not possible to give limits for transient distortion at this time (see Report 636).

#### D.3.5 *Linear distortion*

##### D.3.5.1 *Waveform distortion of the luminance signal*

###### D.3.5.1.1 *Long-time waveform distortion*

It is not possible to give limits for long-time waveform distortion at this time (see Report 636).

###### D.3.5.1.2 *Field-time waveform distortion*

Field-time waveform distortion should not exceed  $\pm 6\%$ .

*Note* – This objective applies to circuits which do not contain waveform clamping devices.

### D.3.5.1.3 Line-time waveform distortion

Line-time waveform distortion should not exceed  $\pm 3\%$ . This figure applies to a measurement on the top of the bar. A limit for base-line distortion requires further study.

### D.3.5.1.4 Short-time waveform distortion

The sine-squared pulse-to-bar ratio should lie within the limits  $100 \pm 12\%$ , corresponding to  $K_{(P/B)} = 3\%$ .

The pulse lobes should lie within the limits shown in Fig. 29a for 625-line systems and in Fig. 29b for 525-line systems, corresponding to  $K_{(2T)} = 3\%$ .

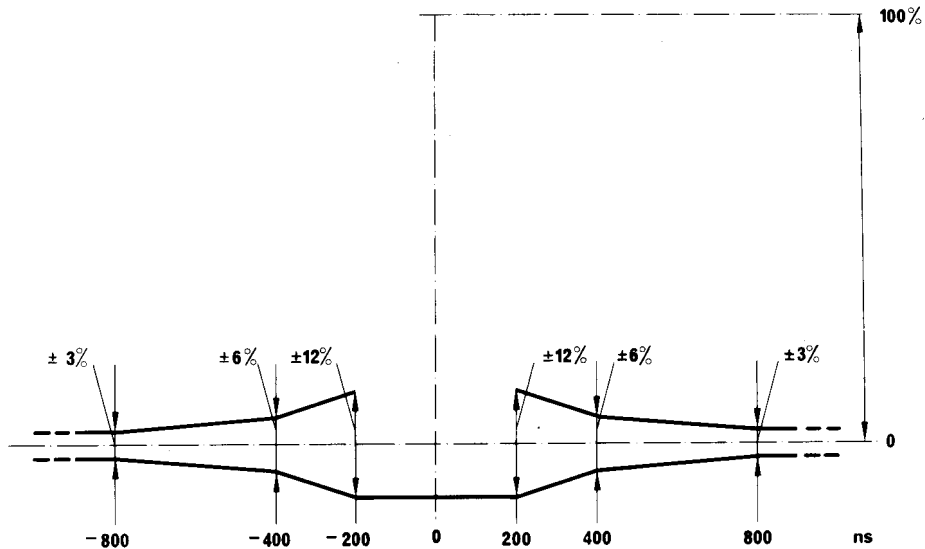

FIGURE 29a – Mask for response to test signal B1 (625-lines)  
(Half-amplitude duration 200 ns)

d31-sc

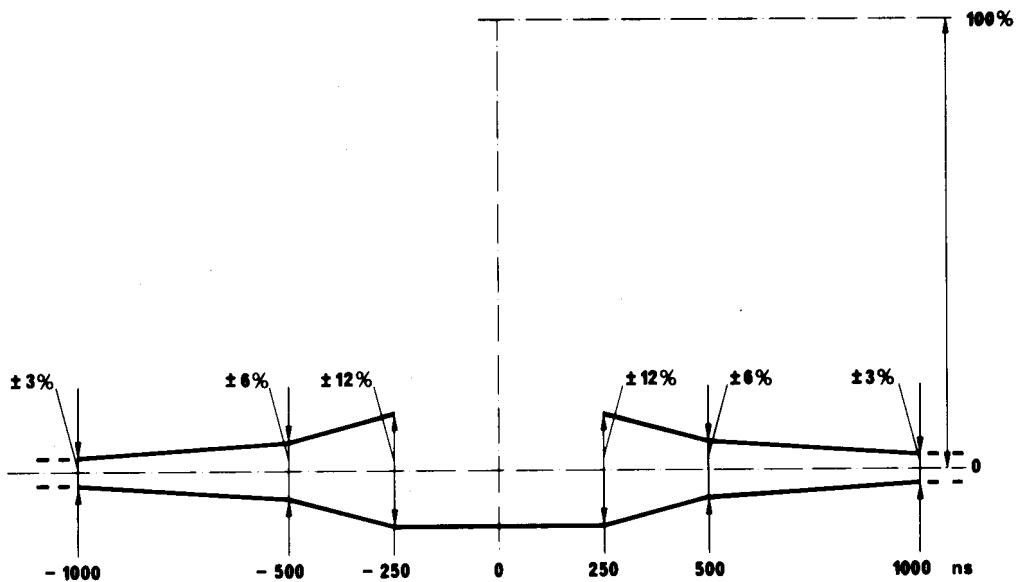

FIGURE 29b – Mask for response to test signal B1 (525-lines)  
(Half-amplitude duration: 250 ns)

d32-sc

The response to *B2* or *B3* test signals for 525-line systems in Japan and Canada only should lie within the limits shown in Fig. 29c.

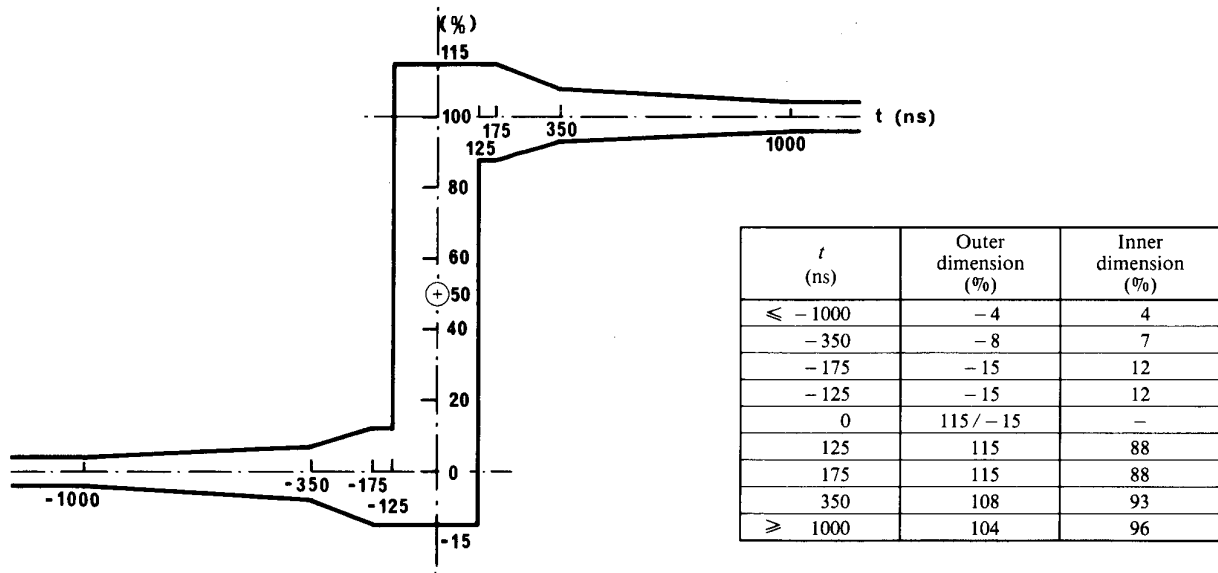

FIGURE 29c — Mask for response to *B2* or *B3* test signals (525-lines for Japan and Canada only)  
(Time of rise: approx. 125 ns)

*Note* — The mask depicted in Fig. 29c is based on a reference distortion (*S*) of 3% [CCIR, 1978-82a, b; Siocos and Chouinard, 1979]. For other values of reference distortion (*S*), the graticule dimensions at the critical points of inflection (at ±175, ±350 and ±1000 ns) are given by the following:

$$\text{Outer dimension: } (100+) \text{ or } (0-) \frac{100 \cdot S \cdot A}{100 - S \cdot A} \%$$

$$\text{Inner dimension: } (100-) \text{ or } (0+) \frac{100 \cdot S \cdot A}{100 + S \cdot A} \%$$

where *S* is the defined reference distortion (%) and *A* is the weighting constant at the critical points of inflection given for *t*(ns) relative to the reference time at the graticule centre as follows:

TABLE II

<i>t</i> (ns)	<i>A</i>
± 175	4.455
± 350	2.4128
± 1000	1.3414

d33-sc

The response to *B2* or *B3* test signals for 525-line systems in the United States of America only should lie within the limits shown in Fig. 29d.

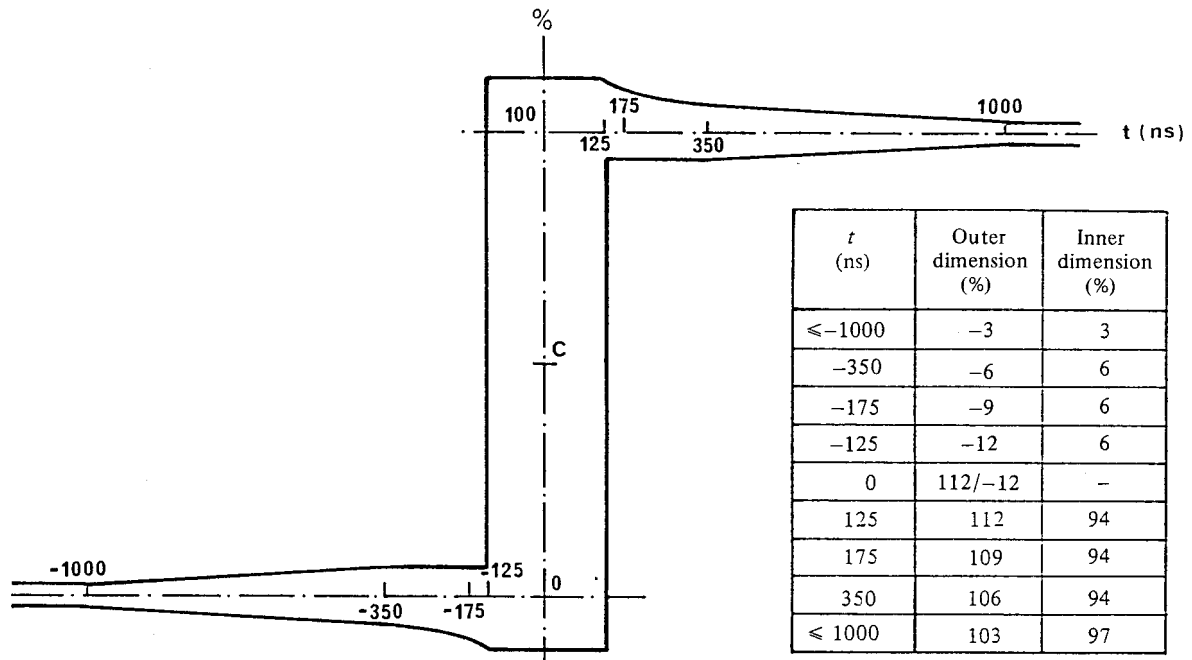

FIGURE 29d – Mask for response to *B2* or *B3* test signals  
(525-lines for the United States of America only)  
(Time of rise: approximately 125 ns)

Note – The mask depicted in Fig. 29d is based on a reference distortion ( $S$ ) of 3% [IEEE, 1979].

d34-sc

#### D.3.5.2 Chrominance waveform distortion

Refer to § C.3.5.2.

#### D.3.5.3 Chrominance-luminance inequalities

##### D.3.5.3.1 Gain inequality

Gain inequality should not exceed  $\pm 10\%$ .

##### D.3.5.3.2 Delay inequality

Delay inequality should not exceed  $\pm 100$  ns.

#### D.3.5.4 Steady-state characteristics

The following limits may be found useful by designers but, because the relationships between time domain and frequency domain characteristics are so complex, their use may sometimes give rise to results which conflict with those obtained with test waveforms. If this occurs the waveform results should be considered to be definitive.



#### D.3.5.4.1 Gain

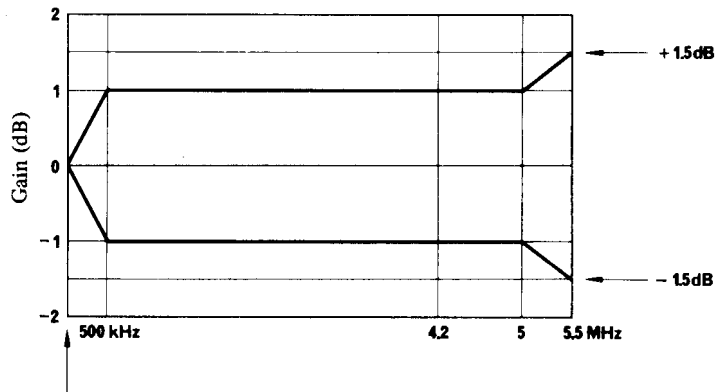

Approx.  
150 kHz<sup>(1)</sup>

FIGURE 30 – Limits for gain/frequency characteristic

(1) May be referred to element C1 of test signal C.

Note – For 525-line transmission the limits need be met up to a frequency of only 4.2 MHz.

d35-sc

#### D.3.5.4.2 Delay

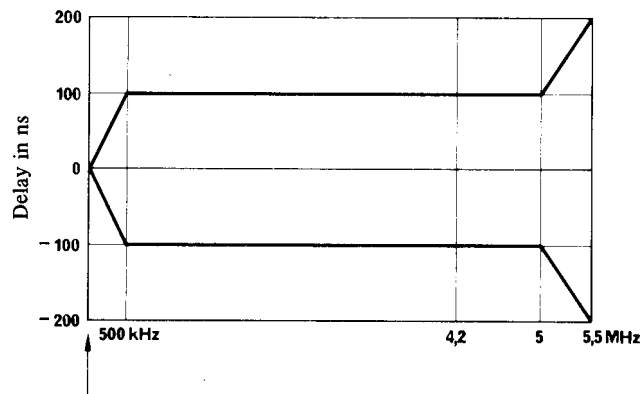

Approx.  
150 kHz

FIGURE 31 – Limits for delay/frequency response characteristic

Note – For 525-line transmission the limits need be met up to a frequency of only 4.2 MHz.

d36-sc

#### REFERENCES

IEEE [1979] Video signal transmission measurement of linear waveform distortion. IEEE Standard 511-1979.

SIOCOS, C. A. and CHOUINARD, G. [June, 1979] Subjective impairment units in relation with oscilloscope graticules for evaluating short-time linear waveform distortion of the luminance signal in 525-line television. *IEEE Trans. Broadcasting*, Vol. BC-25, 2, 63-71.

#### CCIR Documents

[1970-74]: a. CMTT/207 (Italy); b. CMTT/65 (Italy).

[1978-82]: a. CMTT/74 (Canada); b. CMTT/227 (Japan).

PART E – PERFORMANCE OF CIRCUITS SHORTER  
OR LONGER THAN THE HYPOTHETICAL REFERENCE CIRCUIT

**E.1 Introduction**

The purpose of Part E is to give some indication of the performance of circuits that have fewer or more video-to-video sections than the three sections of the hypothetical reference circuit as defined in § A.1.2 of this Recommendation. The effect of the length and the configuration of the circuit relative to the hypothetical reference circuit is also considered. The laws of addition in such circuits may be accurately established only if the statistical behaviour and the composition of the instantaneous values of the parameters is known [Lari *et al.*, 1974].

The values calculated from Tables III and IV provide only indications of the probable performance but for differential phase and gain, and luminance-chrominance gain inequality, such values may be considered accurate enough for practical applications. These values should be used with caution when studying the design of equipment because the laws of addition are not precisely known for every type of impairment.

**E.2 Laws of addition**

E.2.1 *Comments on the use of the laws of addition*

The definition of a circuit in terms of a single multiple of the hypothetical reference circuit is impossible if the number of video-to-video sections and the length of the circuit differ from those of the hypothetical reference circuit by different ratios, i.e. if  $n/3 \neq L/l$  where

- $n$  : number of video-to-video sections,
- $L$  : length of the circuit,
- $l$  : 2500 km.

In such cases two definitions of the circuit in terms of the hypothetical reference circuit should be used, one for those parameters primarily proportional to the circuit configuration, and a second for those parameters (e.g. continuous random noise) primarily proportional to the length of the circuit.

TABLE III

$n$	$\left(\frac{n}{3}\right)^{1/h}$		
	$h = 1$	$h = 3/2$	$h = 2$
1	0.33	0.48	0.58
2	0.67	0.76	0.82
3	1.00	1.00	1.00
4	1.33	1.21	1.15
5	1.67	1.41	1.29
6	2.00	1.59	1.41
7	2.33	1.76	1.53
8	2.67	1.92	1.63
9	3.00	2.08	1.73
10	3.33	2.23	1.83
11	3.67	2.38	1.91
12	4.00	2.52	2.00
13	4.33	2.66	2.08
14	4.67	2.79	2.16
15	5.00	2.92	2.24

TABLE IV

§ of Part B	Characteristic	$D_3$ expressed in	$h$ <sup>(1)</sup>	Notes
3.1	<i>Insertion gain (error)</i>	dB	2	
	<i>Insertion gain variations</i>	dB	2	
3.2.1	<i>Continuous random noise</i>			1, 8
3.2.2	<i>Low-frequency noise</i>	dB	No law	–
3.2.3	<i>Periodic noise</i> Power-supply hum Single frequency	{ Noise voltage	2 2	2, 7 3
3.2.4	<i>Impulsive noise</i>	Noise voltage		4
3.3	<i>Crosstalk</i>	Crosstalk voltage	3/2	
3.4.1	<i>Non-linear distortion of the picture signal</i> Luminance Chrominance gain Chrominance phase Chrominance-to-luminance intermodulation Differential gain Differential phase	% % Degrees % % Degrees	3/2 3/2 3/2 2 3/2 or 2 3/2 or 2	– – – – 9 9
3.4.2	<i>Non-linear distortion of the synchronizing signal</i> Steady state distortion	%	3/2	
3.5.1	<i>Linear waveform distortion</i> Long-time waveform distortion Field-time waveform distortion Line-time waveform distortion Short-time waveform distortion	% % $K_{(P/B)}$ , % $K_{(2T)}$ , % or $S$ , %	1 2 2 3/2 3/2	11  10 10
3.5.3	<i>Chrominance-luminance inequalities</i> Gain inequality Delay inequality	% ns	2 2	5 5
3.5.4	<i>Steady state characteristics</i> Gain/frequency Delay frequency	dB $\mu$ s	3/2 3/2	6 6

<sup>(1)</sup> Further information on laws of addition is to be found in [CCIR, 1966-69a], [CCIR, 1970-74b and c] and Report 636.

*Note 1* – For circuits on coaxial cables, quadratic addition ( $h = 2$ ) applies to random noise expressed in terms of r.m.s. voltage. For circuits on radio-relay links, see Recommendation 555.

*Note 2* – Considering the probability of arithmetic addition of power-supply hum in circuits of few sections, it may be advisable to put  $h = 1$  when  $n \leq 3$ .

*Note 3* – Considering the probability of arithmetic addition when periodic noise consists of a few components that are very close in frequency, it may be advisable to put  $h = 1$  when the number of such components is small.

*Note 4* – When each of a number of sources of impulsive noise is operative for a small percentage of the time (e.g. < 0.1%), arithmetic addition of the percentages will apply.

*Note 5* – Quadratic addition ( $h = 2$ ) for gain and delay inequalities is based on the assumption that positive and negative values are made equally likely by the use of correcting networks or equivalent means.

*Note 6* – In Canada and in the United States of America, the practice is to use  $h = 2$ .

*Note 7* – Further information is given in [CCIR, 1966-69b].

*Note 8* – Further information is given in [CCIR, 1970-74d].

*Note 9* – Use  $h = 2$  if the link is equalized with respect to the mean values of differential gain and phase, otherwise  $h = 3/2$ .

*Note 10* – See Part C, Annex IV.

*Note 11* – No values yet assigned.

### E.2.2 *Law pertaining to circuit configuration*

For the first definition of the circuit in terms of the hypothetical reference circuit use the following equation for all parameters in Table IV except for “continuous random noise”.

If  $D_3$  : design objective as expressed in this Recommendation, or the parameter derived therefrom and indicated in Table IV, that is permitted in the hypothetical reference circuit, and

$D_n$  : performance, or the parameter mentioned above, permitted in  $n$  sections, then

$$D_n = D_3 \left( \frac{n}{3} \right)^{1/h}$$

where  $h$  has the value 1, 3/2 or 2 in accordance with Table IV:  $h = 1$  gives linear or arithmetic law of addition,  $h = 3/2$  gives the “three-halves power” law of addition and  $h = 2$  gives the quadratic (r.s.s.) law of addition.

Calculated values of  $(n/3)^{1/h}$  are given in Table III.

### E.2.3 *Law pertaining to circuit length*

For the second definition of the circuit in terms of the hypothetical reference circuit use the following equations for “continuous random noise voltage” only. When distance is considered the law of addition becomes:

$$D_n = D_3 \left( \frac{L}{l} \right)^{1/h}$$

where  $D_n$ ,  $D_3$ ,  $L$  and  $l$  are as defined in § E.2.1 and E.2.2. If  $20 \text{ km} \leq L \leq 280 \text{ km}$ , set  $L = 280 \text{ km}$  in the expression for  $D_n$ .

*Note 1* – Further information on this additional law is to be found in [CCIR, 1970-74a; 1982-86].

*Note 2* – A national network may include many circuits less than 20 km in length. The signal/noise ratio required for such circuits depends on the number which may be used in a chain. The value chosen is considered to be a national matter, but, desirably it should be compatible with the requirements for the international hypothetical reference circuit.

### E.2.4 *Tables and formulas for the addition of noise voltages and distortions*

For practical applications the following information is useful for the addition of distortions with differing magnitudes.

– Addition of two noise voltages:

If  $S$  is the difference between the higher signal-to-noise ratio  $r_2$  and the lower signal-to-noise ratio  $r_1$  (in dB), the resulting signal-to-noise ratio  $r_{res}$  after addition will be:

$$r_{res} = r_1 - X(S)$$

where  $X(S)$  (dB) is obtained from Table V for the difference value  $S$ .

– Addition of two distortions:

If  $T$  is the numerical ratio between the distortion  $D_2$  with the greater magnitude and the distortion  $D_1$  with the smaller magnitude, i.e.  $T = D_2/D_1$ , the resulting distortion  $D_{res}$  will be:

$$D_{res} = D_2 \cdot Y(T, h)$$

where  $Y(T, h)$  is obtained from Table VI for the value  $T = D_2/D_1$ .

$D_{res}$  can also be calculated from the following:

$$D_{res} = [D_1^h + D_2^h]^{1/h} = D_2 [1 + T^{-h}]^{1/h}$$

TABLE V

$S$ (dB)	0	1	2	3	4	5	6	7	8	9	10	11	12	13	14	15	16	17	18	19	20
$X$ (dB)	3.0	2.5	2.1	1.8	1.5	1.2	1.0	0.8	0.6	0.5	0.4	0.3	0.3	0.2	0.2	0.1	0.1	0.1	0.1	0.05	0.0

TABLE VI

$T$		1	1.5	2	2.5	3	3.5	4	5	6	7	8	9	10
$Y(T, h)$	$h = 1$	2.00	1.67	1.50	1.40	1.33	1.29	1.25	1.20	1.17	1.14	1.13	1.11	1.10
	$h = 3/2$	1.59	1.34	1.22	1.16	1.13	1.10	1.08	1.06	1.04	1.04	1.03	1.03	1.02
	$h = 2$	1.41	1.20	1.12	1.08	1.05	1.04	1.03	1.02	1.01	1.01	1.01	1.01	1.01

REFERENCES

LARI, M., MORGANTI, G. and SANTORO, G. [February, 1974] The statistical addition of distortion in transmission systems. *EBU Rev. Tech.*, 143.

*CCIR Documents*

[1966-69]: **a.** CMTT/170 (OIRT); **b.** CMTT/49 (OIRT).

[1970-74]: **a.** CMTT/42 (Germany (Federal Republic of)); **b.** CMTT/149 (Canada); **c.** CMTT/57 (Italy); **d.** CMTT/56 (Italy).

[1982-86]: CMTT/17 (Germany (Federal Republic of)).

BIBLIOGRAPHY

D'AMATO, P. [April, 1976] The determination of tolerances for chains of television circuits. *EBU Rev. Tech.*, 156